

**ELMO**

VISUAL PRESENTER  
**HV-3000XG**

**INSTRUCTION MANUAL**

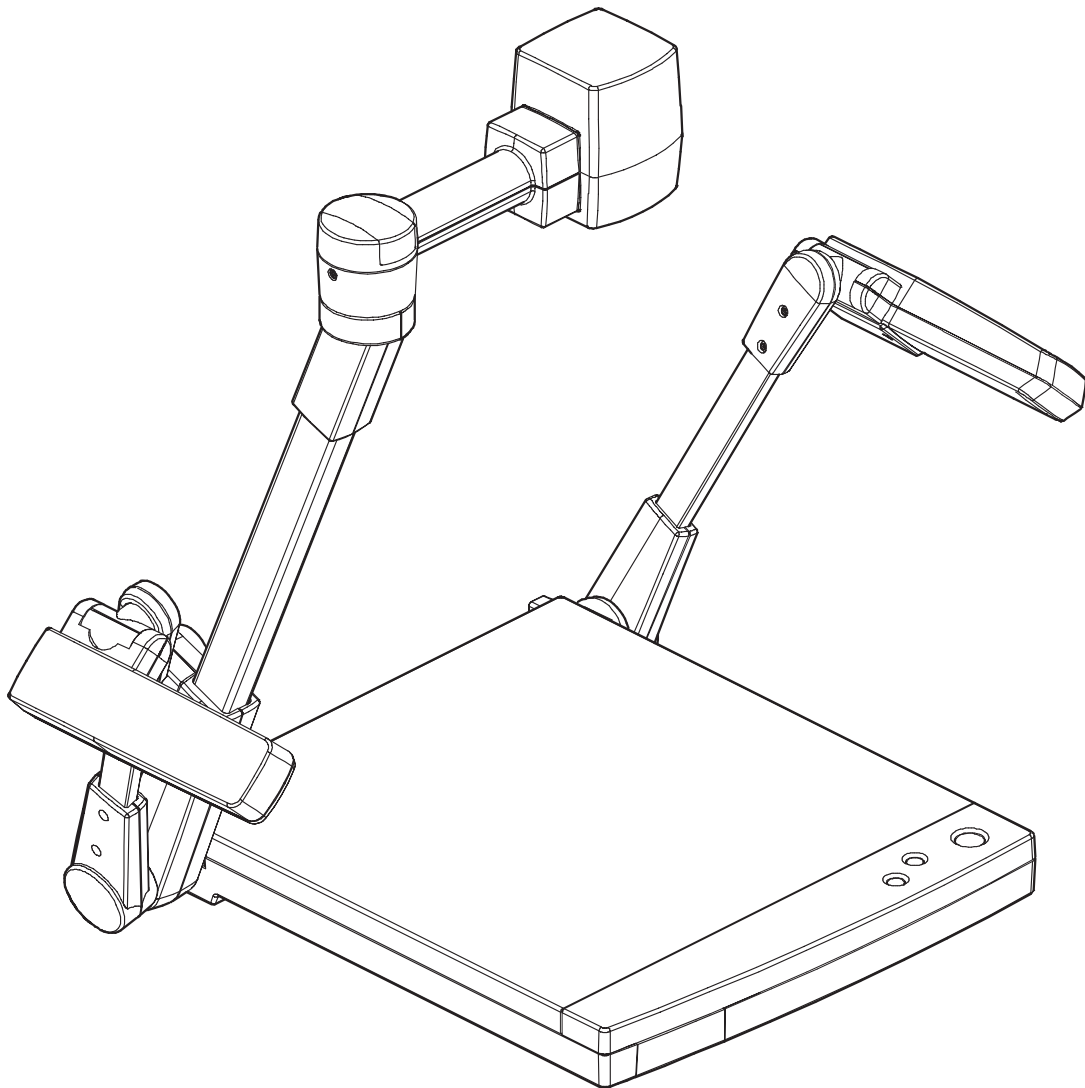

Please read this instruction manual carefully before using this Visual Presenter and keep it for future reference.

# IMPORTANT SAFEGUARDS

■ **Read Instructions** – All the safety and operating instructions should be read before the appliance is operated.

■ **Retain Instructions** – The safety and operating instructions should be retained for future reference.

■ **Heed Warnings** – All warnings on the product and in the operating instructions should be adhered to.

■ **Follow Instructions** – All operating and use instructions should be followed.

■ **Cleaning** – Unplug this product from the wall outlet before cleaning. Do not use liquid cleaners or aerosol cleaners. Use a damp cloth for cleaning.

■ **Attachments** – Do not use attachments not recommended by the product manufacturer as they may cause hazards.

■ **Water and Moisture** – Do not use this product near water - for example, near a bath tub, wash bowl, kitchen sink, or laundry tub, in a wet basement, or near a swimming pool, and the like.

■ **Accessories** – Do not place this product on an unstable cart, stand, tripod, bracket, or table. The product may fall, causing serious injury to a child or adult, and serious damage to the product. Use only with a cart, stand, tripod, bracket, or table recommended by the manufacturer, or sold with the product. Any mounting of the product should follow the manufacturer's instructions, and should use a mounting accessory recommended by the manufacturer.

■ **Ventilation** – Slots and openings in the cabinet are provided for ventilation and to ensure reliable operation of the product and to protect it from overheating, and these openings must not be blocked or covered. The openings should never be blocked by placing the product on a bed, sofa, rug, or other similar surface. This product should not be placed in a built-in installation such as a bookcase or rack unless proper ventilation is provided or the manufacturer's instructions have been adhered to.

■ **Power Sources** – This product should be operated only from the type of power source indicated on the marking label. If you are not sure of the type of power supply to your home consult your appliance dealer or local power company. For products intended to operate from battery power, or other sources, refer to the operating instructions.

■ **Grounding or Polarization** – This product may be equipped with either a polarized 2-wire AC line plug (a plug having one blade wider than the other) or a 3-wire grounding type plug, a plug having a third (grounding) pin. The 2-wire polarized plug will fit into the power outlet only one way. This is a safety feature. If you are unable to insert the plug fully into the outlet, try reversing the plug. If the plug still fails to fit, contact your electrician to replace your obsolete outlet. Do not defeat the safety purpose of the polarized plug. The 3-wire grounding type plug will fit into a grounding type power outlet. This is a safety feature. If you are unable to insert the plug into the outlet, contact your electrician to replace your obsolete outlet. Do not defeat the safety purpose of the grounding type plug.

■ **Power-Cord Protection** – Power-supply cords should be routed so that they are not likely to be walked on or pinched by items placed upon or against them, paying particular attention to cords at plugs, convenience receptacles, and the point where they exit from the product.

■ **Lightning** – For added protection for this product during a lightning storm, or when it is left unattended and unused for long periods of time, unplug it from the wall outlet and disconnect the antenna or cable system. This will prevent damage to the product due to lightning and power-line surges.

■ **Overloading** – Do not overload wall outlets, extension cords, or integral convenience receptacles as this can result in a risk of fire or electric shock.

■ **A product and cart combination should be moved with care. Quick stops, excessive force, and uneven surfaces may cause the product and cart combination to overturn.**



■ **Object and Liquid Entry** – Never push objects of any kind into this product through openings as they may touch dangerous voltage points or short-out parts that could result in a fire or electric shock. Never spill liquid of any kind on the product.

■ **Servicing** – Do not attempt to service this product yourself as opening or removing covers may expose you to dangerous voltage or other hazards. Refer all servicing to qualified service personnel.

■ **Damage Requiring Service** – Unplug this product from the wall outlet and refer servicing to qualified service personnel under the following conditions:

- When the power-supply cord or plug is damaged.
- If liquid has been spilled, or objects have fallen into the product.
- If the product has been exposed to rain or water.
- If the product does not operate normally by following the operating instructions. Adjust only those controls that are covered by the operating instructions as an improper adjustment of other controls may result in damage and will often require extensive work by a qualified technician to restore the product to its normal operation.
- If the product has been dropped or damaged in any way.
- When the product exhibits a distinct change in performance - this indicates a need for service.

■ **Replacement Parts** – When replacement parts are required, be sure the service technician has used replacement parts specified by the manufacturer or have the same characteristics as the original part. Unauthorized substitutions may result in fire, electric shock or other hazards.

■ **Safety Check** – Upon completion of any service or repairs to this product, ask the service technician to perform safety checks to determine that the product is in proper operating condition.

■ **Heat** – The product should be situated away from heat sources such as radiators, heat registers, stoves, or other products (including amplifiers) that produce heat.

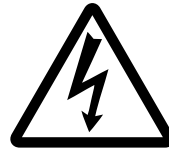
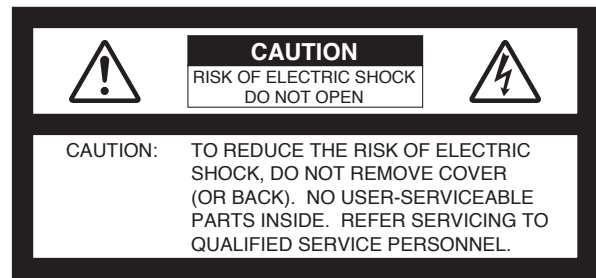

SA 1965

The lightning flash with arrowhead symbol, within an equilateral triangle, is intended to alert the user to the presence of uninsulated "dangerous voltage" within the product's enclosure that may be of sufficient magnitude to constitute a risk of electric shock to persons. This marking is located at the bottom of product.



SA 1966

The exclamation point within an equilateral triangle is intended to alert the user to the presence of important operating and maintenance (servicing) instructions in the literature accompanying the product.

**WARNING:**  
**TO REDUCE THE RISK OF FIRE OR ELECTRIC SHOCK, DO NOT EXPOSE THIS PRODUCT TO RAIN OR MOISTURE.**

**THIS IS A CLASS A PRODUCT. IN A DOMESTIC ENVIRONMENT THIS PRODUCT MAY CAUSE RADIO INTERFERENCE IN WHICH CASE THE USER MAY BE REQUIRED TO TAKE ADEQUATE MEASURES.**

#### **INFORMATION**

This equipment has been tested and found to comply with the limits for a Class A digital device, pursuant to Part 15 of the FCC Rules. These limits are designed to provide reasonable protection against harmful interference when the equipment is operated in a commercial environment. This equipment generates, uses, and can radiate radio frequency energy and, if not installed and used in accordance with the instruction manual, may cause harmful interference to radio communications. Operation of this equipment in a residential area is likely to cause harmful interference in which case the user will be required to correct the interference at his own expense.

#### **USER-INSTALLER CAUTION:**

Your authority to operate this FCC verified equipment could be voided if you make changes or modifications not expressly approved by the party responsible for compliance to Part 15 of the FCC rules.

## BEFORE YOU USE

- Use the Visual Presenter under the rated electrical conditions.
- Do not leave the Presenter under direct sunlight or by heaters, or the Presenter may be discolored, deformed, or damaged.
- Do not place the Presenter in any humid, dusty, windy or vibrating location. Use the Presenter in the following environmental conditions:
  - Temperature : 5°C ~ 40°C (41°F ~ 104°F)
  - Humidity : 30 ~ 85% (No condensation)
- Use a soft, dry cloth for cleaning. Do not use any volatile solvent, such as thinner or benzine.
- Do not directly point the camera lens into the sun, or the camera may be damaged.
- Caring for the batteries :
  - If the Presenter is not used for a long time, take out the batteries from the remote control.
  - Do not use rechargeable Ni-Cd batteries.
  - Do not use new and old batteries, or batteries of different types together.
  - Do not try to recharge or short-circuit the batteries.

# CONTENTS

<b>1. PART NAMES AND FUNCTIONS</b>	<b>6</b>
Appearance	6
Front Operation Panel	7
Rear Panel	7
Wireless Remote Control and Column	9
<b>2. WIRELESS REMOTE CONTROL</b>	<b>10</b>
Preparation	10
<b>3. MOUSE</b>	<b>10</b>
<b>4. SETTING UP</b>	<b>11</b>
Preparation of the Visual Presenter	11
Connection to the monitor and the projector	12
RGB input signal	14
RGB output signal	14
<b>5. OPERATION PROCEDURES</b>	<b>15</b>
Simple steps for presenting printed material	15
Convenient use of the camera	15
<b>6. STORING THE VISUAL PRESENTER</b>	<b>16</b>
<b>7. VARIOUS FUNCTIONS</b>	<b>17</b>
Lighting	17
Zoom	17
Video pointer	18
Focus	18
Iris	19
Pause	20
Auto white balance	20
About the PC software "Image Mate for HV-400XG/3000XG/3500XG"	20

<b>8. OSD (On-Screen Display)</b> .....	<b>21</b>
Display of the OSD menu and the operation of the mouse .....	21
OSD menu .....	22
<b>9. COMMUNICATION THROUGH RS-232C</b> .....	<b>24</b>
Setting up .....	24
Cable connection .....	25
RS-232C connector specifications (DSUB-9P) .....	25
Data format specifications .....	26
Transmission specifications .....	26
Table of the communication commands .....	27
<b>10. TROUBLESHOOTING HINTS</b> .....	<b>29</b>
<b>11. SPECIFICATIONS</b> .....	<b>30</b>
General	
Camera	
Lighting	
Supplied accessories	

# 1. PART NAMES AND FUNCTIONS

## ○ Appearance

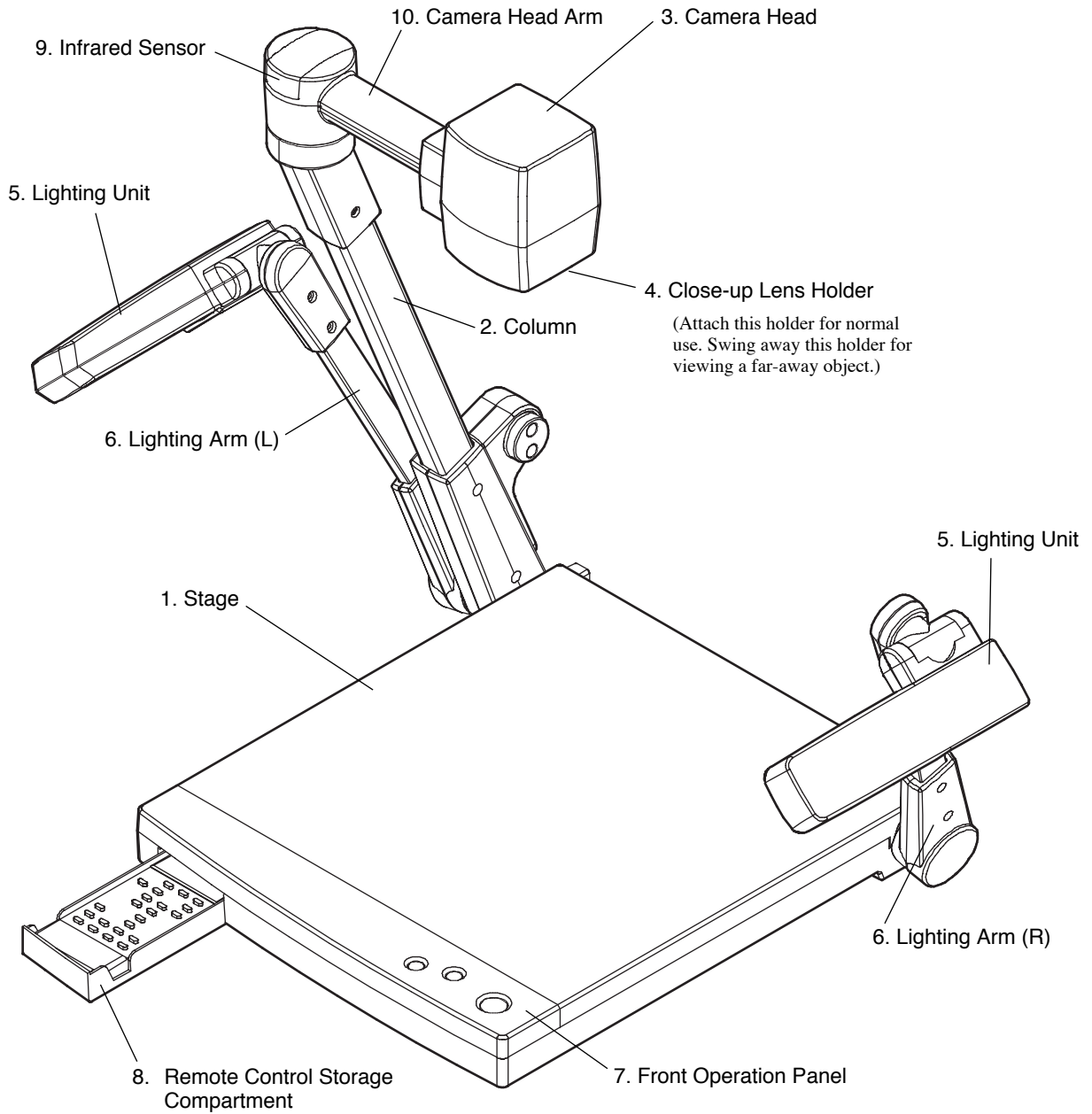

## ○ Front Operation Panel

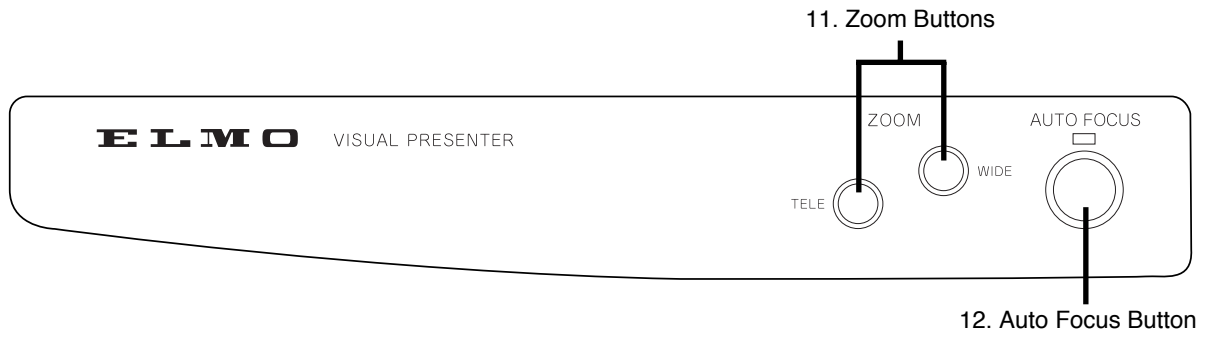

	Name	Function	Reference Page
11	Zoom Buttons	To change the image size.	P.17, P.18
12	Auto Focus Button	To focus automatically (One-shot auto focus).	P.15, P.18

## ○ Rear Panel

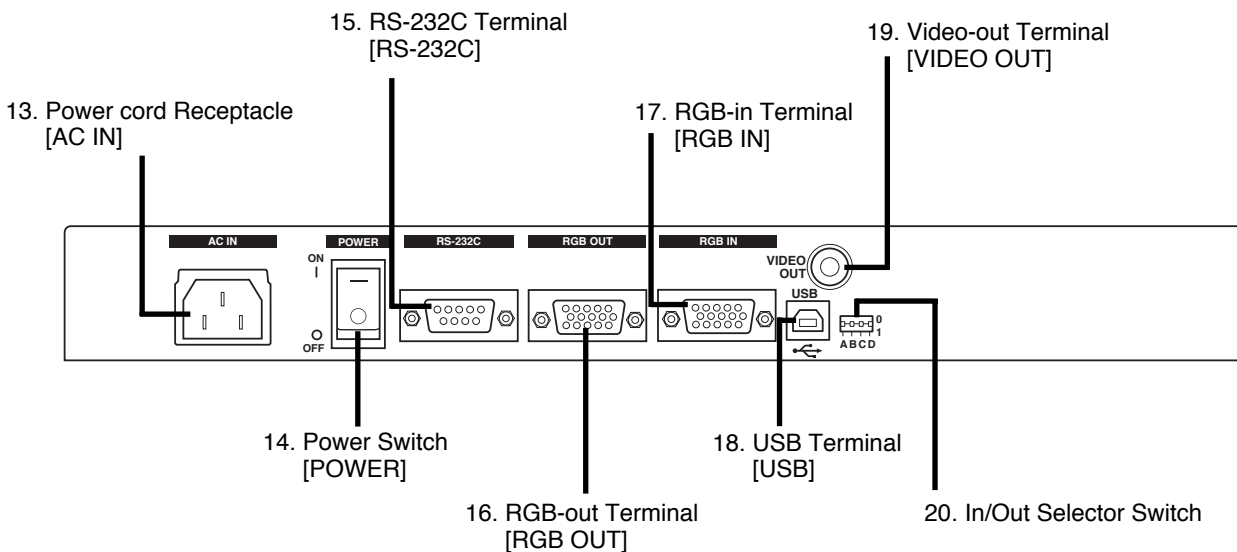

	Name	Function	Reference Page
13	Power Cord Receptacle <b>[AC IN]</b>	To connect the power cord.	—
14	Power Switch <b>[POWER]</b>	To turn ON/OFF the power supply.	P.15
15	RS-232C Terminal <b>[RS-232C]</b>	To connect an RS-232C cable for communication with a PC. The <b>[D]</b> key of the In/Out selector switch enables either one of the following: <ul style="list-style-type: none"> <li>• To control the Visual Presenter from the outside through the RS-232C.</li> <li>• To use the supplied mouse.</li> </ul>	P.24



	Name	Function	Reference Page															
16.	RGB-out Terminal <b>[RGB OUT]</b>	To output the image when connected to RGB input equipment, such as LCD projector and multi-sync monitor.	P.12, P.14															
17.	RGB-in Terminal <b>[RGB IN]</b>	To output the image from RGB-out Terminal <b>[RGB OUT]</b> when RGB1 is selected for input.	P.14															
18.	USB Terminal <b>[USB]</b>	To connect a USB cable. When the supplied USB cable is connected here, the image can be captured or the Presenter can be controlled on the supplied CD-ROM "Image Mate for HV-400XG/3000XG/3500XG."	P.20															
19.	Video-out Terminal <b>[VIDEO OUT]</b>	To connect to a monitor or other output equipment.	P.12															
20.	In/Out Selector Switch	<p>To select In/Out as follows:</p> <p><input type="radio"/> <b>[A]</b> key To select the image output from RGB-out terminal <b>[RGB OUT]</b>.</p> <ul style="list-style-type: none"> <li><input type="checkbox"/> XGA output</li> <li><input type="checkbox"/> TV output</li> </ul> <p><b>Note:</b> When "TV output" is selected, only the presenter image can be seen on TV monitor. (not picture from <b>[RGB IN]</b>.)</p> <p><input type="radio"/> <b>[B]</b> key To select the TV output system.</p> <ul style="list-style-type: none"> <li><input type="checkbox"/> NTSC</li> <li><input type="checkbox"/> PAL</li> </ul> <p><input type="radio"/> <b>[C]</b> key To select the shutter frequency. In the area where the power frequency for the shutter is 50Hz, the screen may flicker due to AC discharge lamp, such as fluorescent lamp and mercury lamp. This flicker may be reduced by setting the switch to 50Hz.</p> <ul style="list-style-type: none"> <li><input type="checkbox"/> 60Hz</li> <li><input type="checkbox"/> 50Hz</li> </ul> <p><input type="radio"/> <b>[D]</b> key To select the RS-232C.</p> <ul style="list-style-type: none"> <li><input type="checkbox"/> Use of the mouse</li> <li><input type="checkbox"/> Control of the Presenter</li> </ul> <p style="text-align: center;">Key arrangement and their functions</p> <table border="1" style="margin-left: auto; margin-right: auto;"> <thead> <tr> <th></th> <th>A</th> <th>B</th> <th>C</th> <th>D</th> </tr> </thead> <tbody> <tr> <td><b>0</b></td> <td>XGA</td> <td>NTSC</td> <td>60Hz</td> <td>Mouse</td> </tr> <tr> <td><b>1</b></td> <td>TV</td> <td>PAL</td> <td>50Hz</td> <td>Control</td> </tr> </tbody> </table>		A	B	C	D	<b>0</b>	XGA	NTSC	60Hz	Mouse	<b>1</b>	TV	PAL	50Hz	Control	P.10, P12
	A	B	C	D														
<b>0</b>	XGA	NTSC	60Hz	Mouse														
<b>1</b>	TV	PAL	50Hz	Control														

## ○ Wireless Remote Control

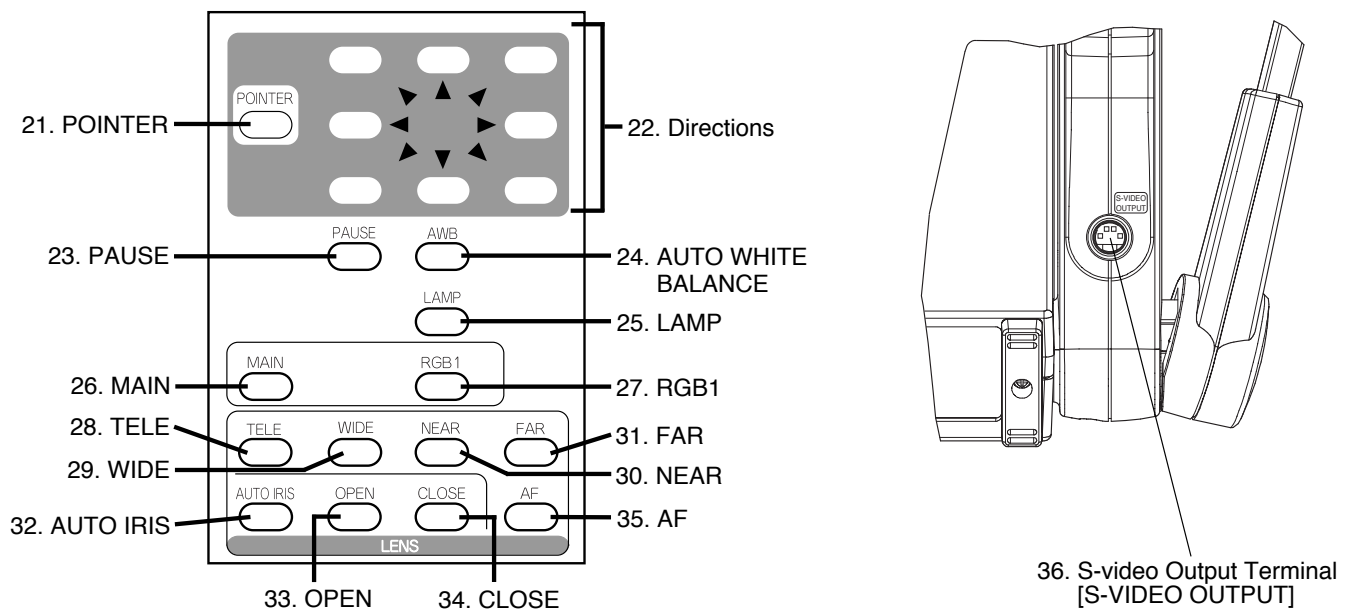

	Button Name	Function	Reference Page
21	<b>POINTER</b>	To display the video pointer on the screen.	P.18
22	<b>Directions</b>	To move the video pointer while it is displayed.	P.18
23	<b>PAUSE</b>	To make the image pause still.	P.20
24	<b>AWB</b>	To obtain the white balance automatically.	P.20
25	<b>LAMP</b>	To turn ON/OFF the upper lighting units.	P.17
26	<b>MAIN</b>	To switch the image output of the RGB-out terminal <b>[RGB OUT]</b> to the Presenter camera image.	—
27	<b>RGB1</b>	To switch the image output of the RGB-out terminal <b>[RGB OUT]</b> to RGB-in Terminal <b>[RGB IN]</b> . <b>Note:</b> When <b>[1]</b> (TV) is chosen by <b>[A]</b> key of the In/Out selector switch in the rear, the video image on TV cannot be changed.	—
28	<b>TELE</b>	To zoom in.	P.15,P.17,P.18
29	<b>WIDE</b>	To zoom out.	P.15, P.17
30	<b>NEAR</b>	To move the focus near.	P.19
31	<b>FAR</b>	To move the focus far.	P.19
32	<b>AUTO IRIS</b>	To set the initial setting.	P.19
33	<b>OPEN</b>	To open the iris.	P.19
34	<b>CLOSE</b>	To close the iris.	P.19
35	<b>AF</b>	To focus automatically.	P.15, P.18
36	S-video output Terminal <b>[S-VIDEO OUTPUT]</b>	To connect to a monitor or other equipment.	P.13

## 2. WIRELESS REMOTE CONTROL

Point the infrared emitting part of the wireless remote control unit at the infrared sensor of the Visual Presenter, located on the top of the column, and press the button for the desired function.

The receivable range may be narrowed when the Presenter is placed under sunlight, near an inverter fluorescent lamp or in any other unfavorable surroundings. Depending on the conditions of fluorescent lamps, etc. the sensor may fail to receive the infrared light. In such a case, relocate the Presenter, or take other countermeasures.

### Receivable range

Distance : Approx. 7 m (23 ft.) or less from the light receiving area to the front of the wireless remote control

Angle : Approx. 30 degrees or less from the light receiving area to the front of the wireless remote control rightward, leftward, upward and downward, respectively

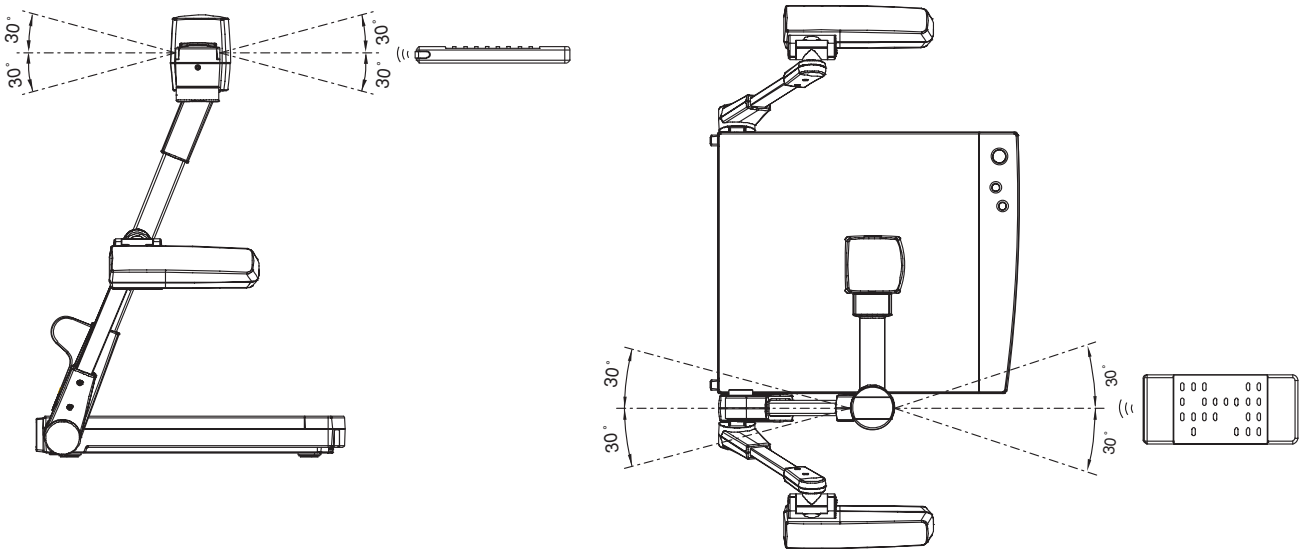

### ○ Preparation

Remove the battery case cover by pressing downward on the [▼] mark part in the direction as indicated by the arrow. Install 2 pcs of batteries (type R03, AAA) into the case in the direction as indicated there.

**Note:** Install the batteries with the right polarity.

**Note:** Change the batteries once a year.

**Note:** The batteries supplied with the Presenter are only for use in initially confirming the operation of the Presenter. It is not guaranteed that these batteries can work effectively for the indicated period.

## 3. MOUSE

Select [0] by using the [D] key of the In/Out selector switch, and connect the mouse to the RS-232C terminal on the rear panel. Then, "OSD" and "video pointer" can be displayed and operated.

Reference	• Video pointer	P.18
	• Display of the OSD menu and the operation of the mouse	P. 21

## 4. SETTING UP

### ○ Preparation of the Visual Presenter

(1) Raise the column.

Raise up the column once, and fall it until it is locked.

**Note:** The lighting arm (L) cannot be independently raised.

**Note:** Unless the column is fully raised up, it may not be locked when it is fallen.

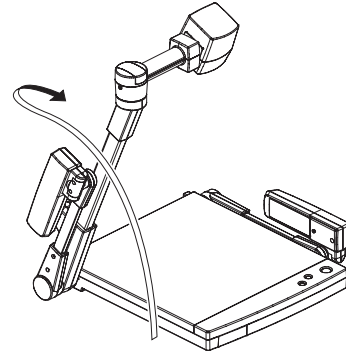

(2) Raise the lighting arm (R) unit, and turn the camera head to direct the lens unit to the stage.

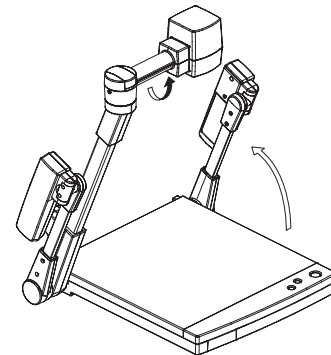

(3) Turn the lighting unit.

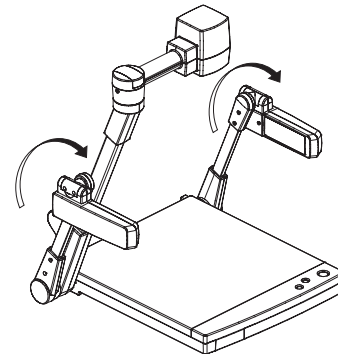

(4) Open the lighting arm unit and the lighting unit.

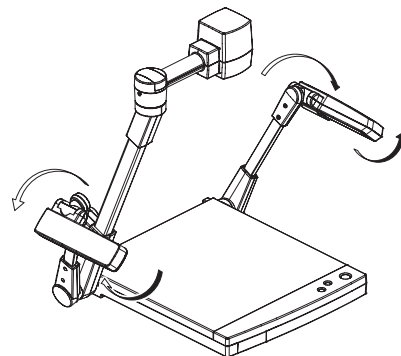

(5) Plug the power cord into the power cord receptacle of the Presenter and the outlet.

## ○ Connection to the monitor and the projector

The Visual Presenter can switch the type of image output by using the In/Out selector switch. Use the In/Out selector switch according to the connection environment. It is set before shipment as follows:

Key	Function	Initial setting	
		Key selection	Contents
A	To switch the image output.	0	XGA output
B	To switch the TV output system.	0	NTSC
C	To switch the shutter frequency.	0	60Hz
D	To switch the RS-232C.	0	Use of the mouse

**Note:** Be sure to turn OFF the power of all peripheral equipment before making any connections to protect the Presenter and all the connected equipment.

**Note:** Be sure to turn OFF the power of the Presenter before switching the key of the In/Out selector switch.

**Note:** Hold the cable plug part when connecting or disconnecting the cables.

## ● Connection to the composite video-in terminal

Connect the video-out terminal [**VIDEO OUT**] of the Presenter and the video in terminal of other equipment with the supplied RCA video cable connection.

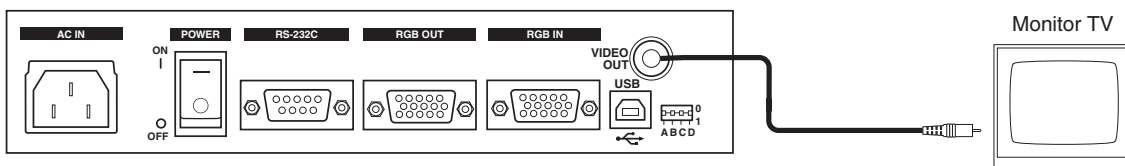

**Note:** The image output from the video-out terminal [**VIDEO OUT**] is only the Presenter camera image.

## ● Connection to the RGB video-out terminal

Connect the RGB-out terminal [**RGB OUT**] of the Presenter and the RGB video-in terminal of equipment with the supplied analog RGB cable or a connection cable available in the market.

At this point, the image position may be shifted from the center. In such a case, adjust manually the horizontal and vertical positions from the connected equipment side.

For LCD projector, vertical stripes may appear on the screen. This can be reduced by manually adjusting the dot clock frequency on the projector side.

**Note:** When the connected equipment requires 5 connections of R, G, B, H and V, select [**XGA**] in the [**A**] key of the In/Out selector switch.

When the connected equipment requires only 3 connections of R, G and B, select [**TV**] in the [**A**] key of the In/Out selector switch.

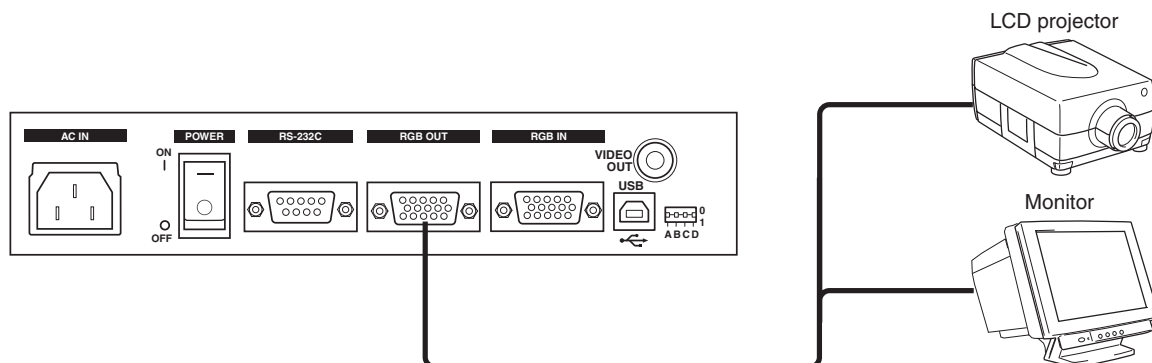

● **Connection to the S-Video terminal**

Connect the S-video output terminal [**S-VIDEO OUTPUT**] of the Column of the Presenter and the video-in terminal of other equipment with the supplied S-video cable.

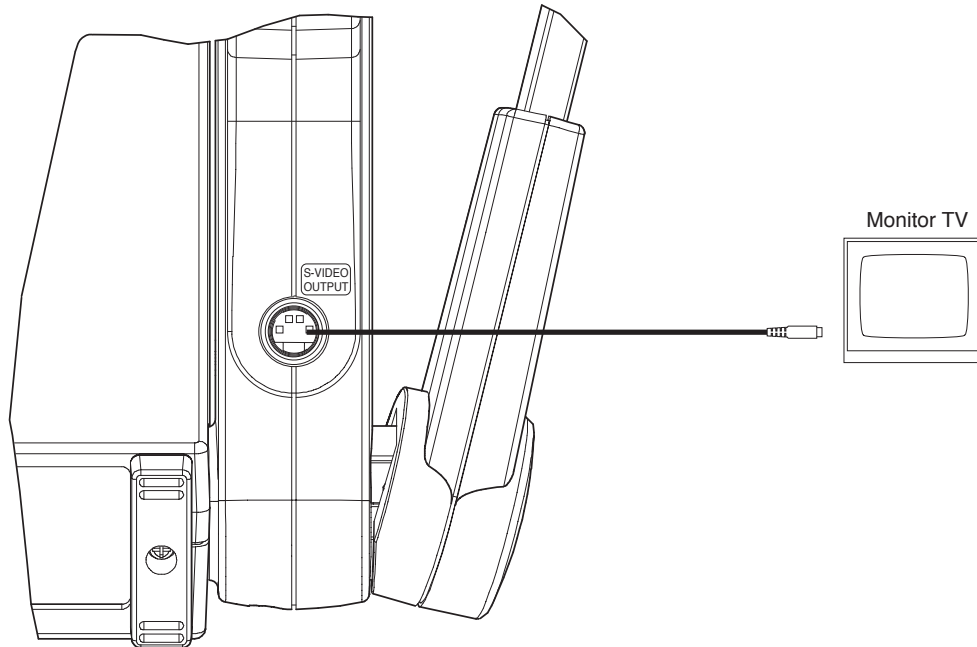

**Note:** The image output from the S-video output terminal [**S-VIDEO OUTPUT**] is only the Presenter camera image.

## ○ RGB input signal

### ● Signal assignment

Pin No.	Name	Pin No.	Name	Pin No.	Name
1	Video signal (Red)	6	GND (Red)	11	GND
2	Video signal (Green)	7	GND (Green)	12	NC
3	Video signal (Blue)	8	GND (Blue)	13	Horizontal synchronizing/ Composite synchronizing signal
4	NC	9	NC	14	
5	GND	10	GND	15	NC

### ● Pin arrangement

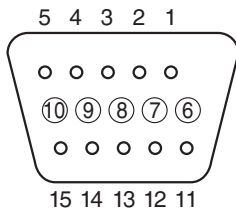

DSUB 15P shrinking terminal (Female)

#### Input signal

Video signal

Analog 0.7V(p-p) 75Ω

Horizontal synchronizing signal

TTL level (positive / negative polarity)

Vertical synchronizing signal

TTL level (positive / negative polarity)

Composite synchronizing signal

TTL level (positive / negative polarity)

## ○ RGB output signal

### ● Signal assignment

Pin No.	Name	Pin No.	Name	Pin No.	Name
1	Video signal (Red)	6	GND (Red)	11	GND
2	Video signal (Green)	7	GND (Green)	12	NC
3	Video signal (Blue)	8	GND (Blue)	13	Horizontal synchronizing signal
4	NC	9	NC	14	Vertical synchronizing signal
5	GND	10	GND	15	NC

### ● Terminal arrangement and analog RGB cable connection

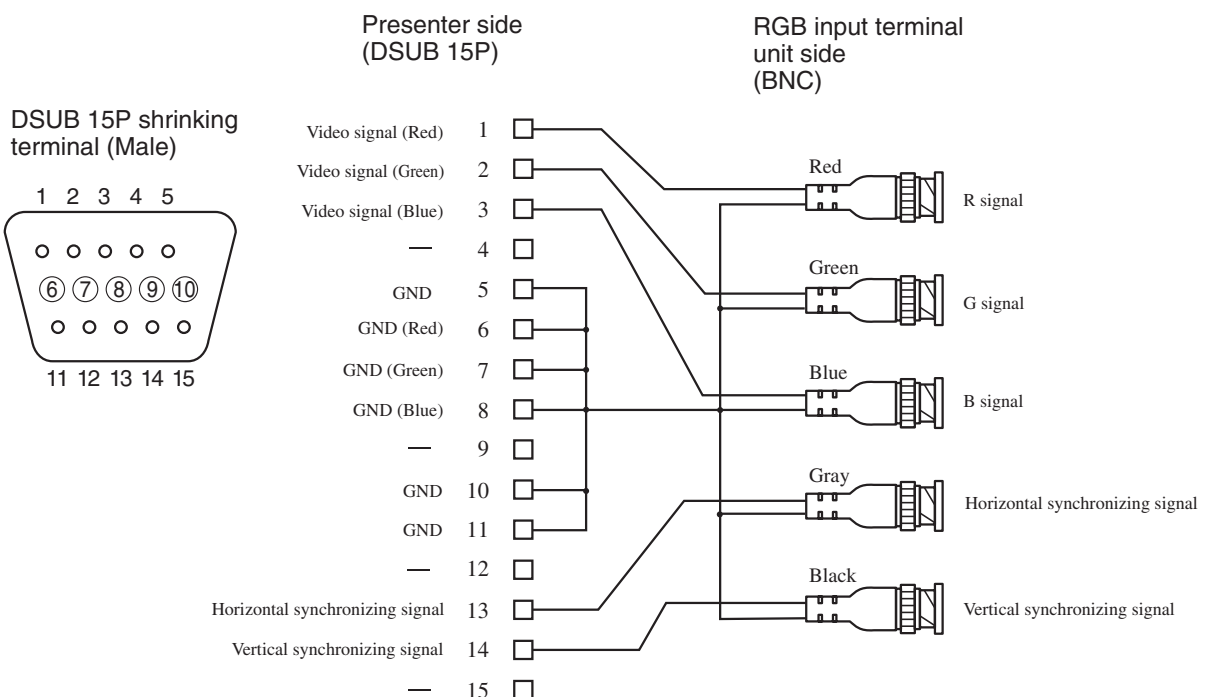

## 5. OPERATION PROCEDURES

### ○ Simple steps for presenting printed material

- (1) Turn ON the power switch.

**Note:** Before turning ON the power switch, connection to the monitor should have been completed.

**Note:** If the power switch is turned ON immediately after being turned OFF, the Visual Presenter may not operate. For restarting, turn ON the power switch several seconds after turning OFF.

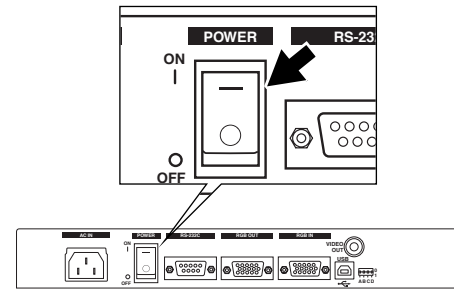

- (2) Place the object on the stage. Adjust the image size according to the object size using the zoom buttons [TELE/WIDE] on the operation panel or wireless remote control, watching the image on the monitor.

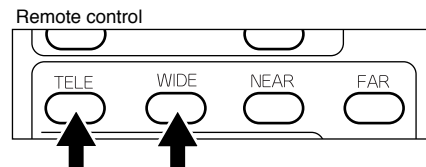
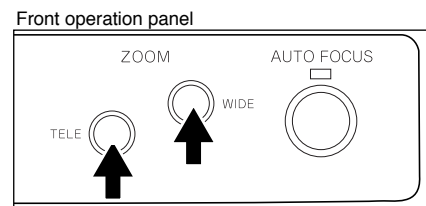

- (3) Press the button [AUTO FOCUS] on the front operation panel or the auto focus button [AF] on remote control for focusing.

**Note:** The auto focus function works up to a height of approx. 15 cm (5.9 in.) above the stage surface on the maximum side of the zoom [TELE] (when a close-up lens is attached).

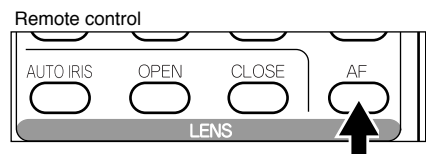
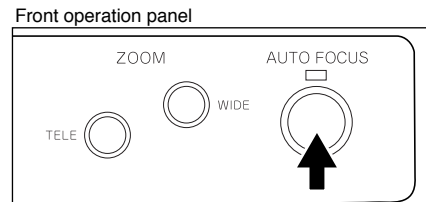

### ○ Convenient use of the camera

When the camera head arm is turned as shown in the right figure, material outside the stage can be photographed. When the camera head unit is set in the horizontal position, wall view, distant view, etc. can be photographed.

When the object is far away, open the close-up lens holder to your side.

**Reference** The focus can be achieved from 0.5 m (20 in.) to ∞ .

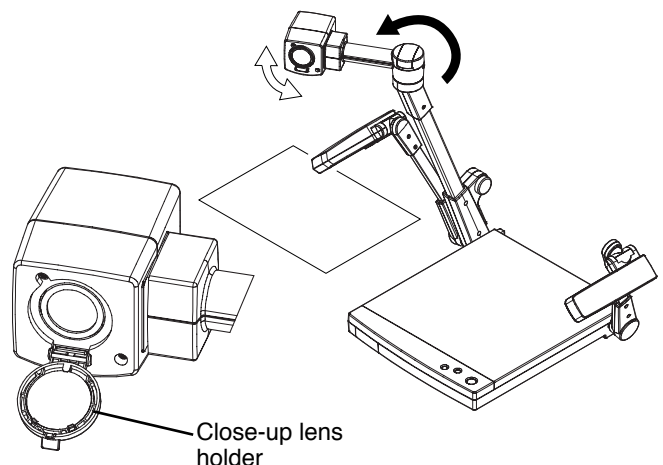



## 6. STORING THE VISUAL PRESENTER

- (1) Turn OFF the power switch, and unplug the power cord and the video cable.

- (2) Close the lighting unit and the lighting arm unit.

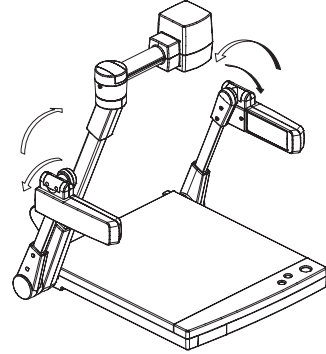

- (3) Turn the lighting unit to the position shown in the right figure.

**Note:** Be sure to return the lighting unit to its original position as shown in the right figure. If it is in any other position when it is put away, the lighting unit may be damaged.

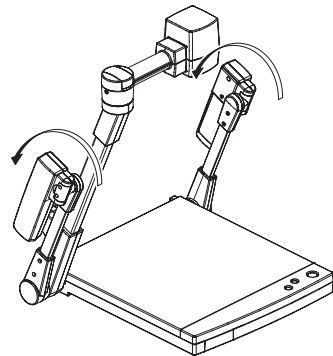

- (4) Fall the lighting arm (R) unit, and turn the camera head to the position shown in the right figure (the position with the camera head slightly turned to the rear side panel).

**Note:** The lighting arm (L) cannot be independently fallen.

**Note:** Be sure to return the camera to its original position as shown in the right figure. If it is in any other position when it is put away, the camera head or the lens may be damaged.

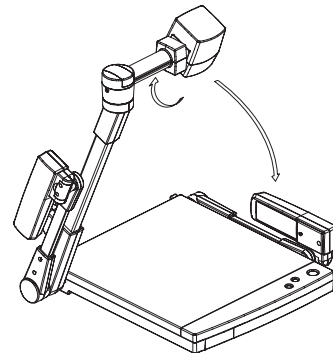

- (5) Raise up the column once, and then fall it.

**Note:** The right storage position of the column is shown in the right figure. Never apply excessive force to the column.

**Note:** Do not hold the head arm unit when carrying the Presenter.

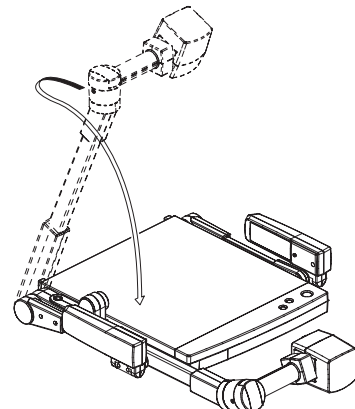



## ○ Video pointer

When the pointer button **[POINTER]** on the wireless remote control is pressed or the left button of the mouse is clicked, the video pointer appears.

The video pointer is moved by using the direction buttons on the wireless remote control or by moving the mouse.

When the pointer button **[POINTER]** on the wireless remote control is pressed or the left button of the mouse is clicked (this switches the OSD display), the video pointer disappears.

Reference		
	• Display of the OSD menu and the operation of the mouse	P.21
	• OSD menu	P.22

**Note:** This function effects only for the image from the RGB-out terminal **[RGB OUT]**.

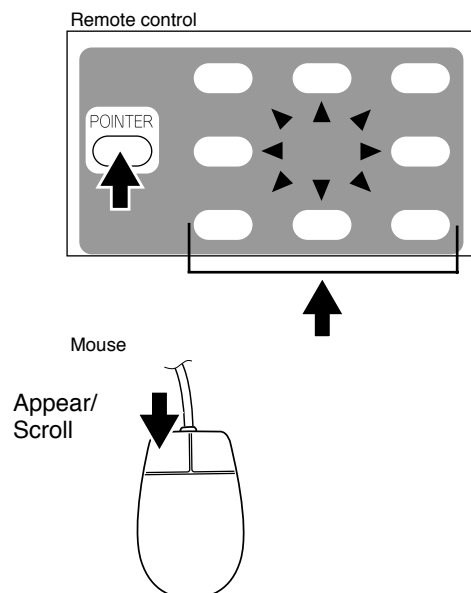

## ○ Focus

### ● Auto Focus

Press the button **[AUTO FOCUS]** on the front operation panel or the auto focus button **[AF]** on the wireless remote control, and the auto focus operation will be activated.

While the auto focus is in operation, the indication lamp blinks until the object is brought into focus.

The Presenter features one-shot auto focus function.

Once focusing is completed, the auto focus function is released, and the focused position maintains unchanged. (FOCUSFREE)

Enlarge the image to the maximum size by pressing the button **[TELE]** on the front operation panel or the zoom button **[TELE]** on the wireless remote control and activate the auto focus operation, and the image will become sharper.

Reference	OSD menu	P.22

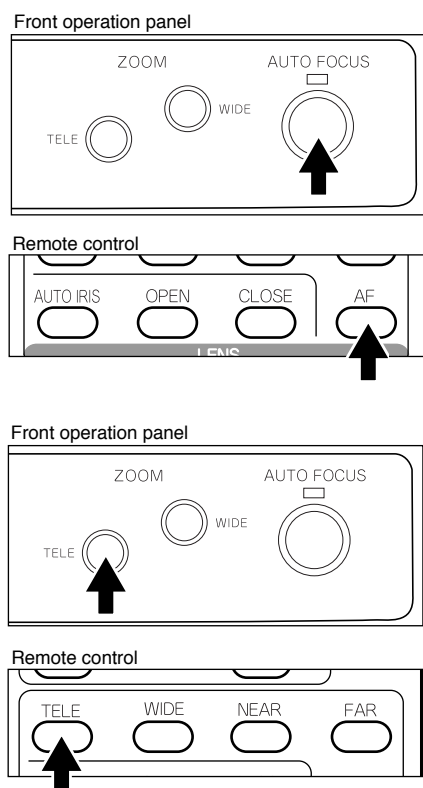

However, the objects listed below may not be brought into focus in the auto focus mode. In these cases, use the manual focus mode.

- Objects bearing little contrast
- Objects with fine repeated patterns, such as lateral stripes and cross stripes
- Objects glittering or reflecting strong light
- Objects with bright background, or excessive contrast
- Objects in a dark picture plane
- Objects located near and far away at the same time.
- Objects in motion

If the focus button **[NEAR]** or **[FAR]** on the wireless remote control is pressed while the auto focus is in operation, the auto focus will be released.

**Note:** The auto focus functions up to approx. 15 cm (5.9 in.) above the stage surface (with the close-up lens attached).

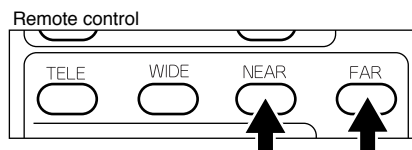

### ● Powered Manual Focus

To focus on any part of the material, such as 3-D material, press the focus button **[NEAR]** or **[FAR]** on the wireless remote control.

**Reference**    OSD menu    P.22

**Note:** The auto focus function works up to a height of approx. 15 cm (5.9 in.) above the stage surface on the maximum side of the zoom **[TELE]** (when a close-up lens is attached).

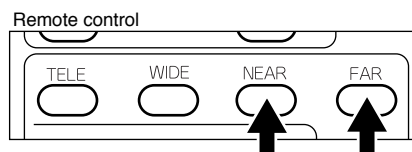

### ○ Iris

The iris level can be adjusted.

To open the iris, press the open button **[OPEN]** on the wireless remote control.

To close the iris, press the close button **[CLOSE]** on the wireless remote control.

To reset the setting to the initial setting, press the auto iris button **[AUTO IRIS]** on the wireless remote control.

**Reference**    OSD menu    P.22

**Note:** If the screen looks dark, press the iris button **[OPEN]** on the wireless remote control to adjust the brightness of the screen.

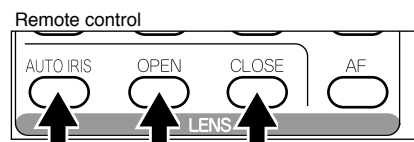

## ○ Pause

When the pause button **[PAUSE]** on the wireless remote control is pressed, the image of the main camera is stored in pause still mode.

When the pause button **[PAUSE]** is pressed again, the pause mode is released.

**Reference**    OSD menu    P.22

**Note:** Pressing the other buttons for each function (except **Directions** and **[POINTER]**) also cancels the pause mode.

**Note:** The pause (still) mode is inactive for the video image from **[VIDEO OUT]**.

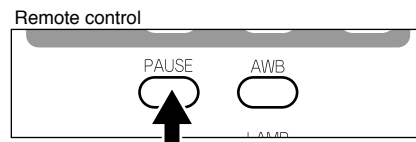

## ○ Auto white balance

When the auto white balance button **[AWB]** on the wireless remote control is pressed, the white balance will be automatically adjusted according to the color temperature.

**Reference**    OSD menu    P.23

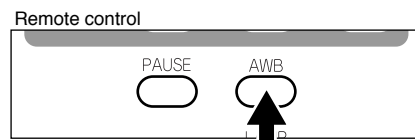

## ○ About the PC software "Image Mate for HV-400XG/3000XG/3500XG"

When the application [Image Mate for HV-400XG/3000XG/3500XG] is installed, the following operation are enabled:

- Image data transfer to the PC
- Operation of the Visual Presenter by the PC

For further detail, refer to the installation manual for the application [Image Mate for HV-400XG/3000XG/3500XG] and the file [manual.pdf] in the CD-ROM.

## 8. OSD (On-Screen Display)

OSD (On-Screen Display) means the operation menu displayed on the screen ("OSD menu"). The operation of Visual Presenter with the mouse can be set from this OSD menu.

**Note:** The OSD function effects only for the image from the RGB-out terminal **[RGB OUT]**.

### ○ Display of the OSD menu and the operation of the mouse

When the left button of the mouse is clicked, the OSD menu and the pointer appear.

Each function item is set by using the mouse.

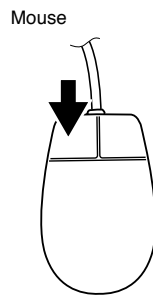

Use the following buttons on the mouse for each function:

- **Left button**-----Each time the mouse is clicked, the pointer and the menu alternately appear and disappear.

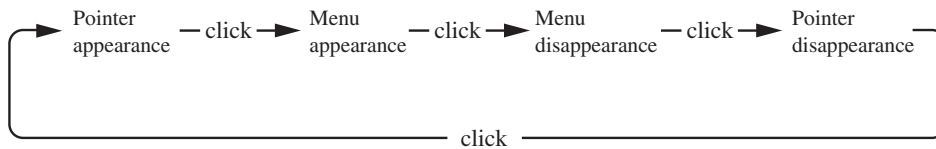

- **Right button**-----Not used.







For the information how to operate the pointer, refer to P.18.

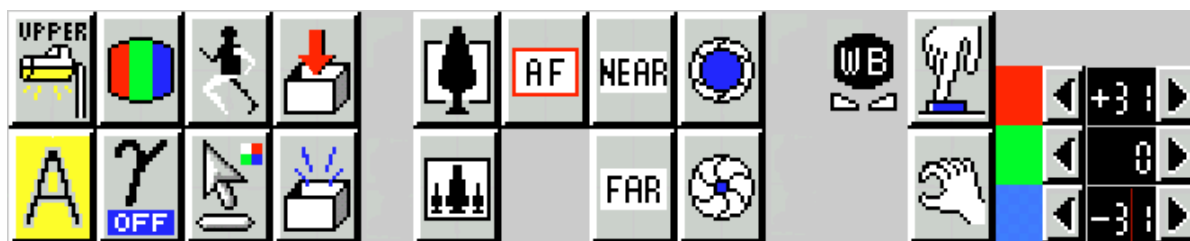





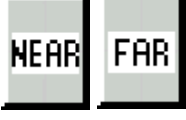
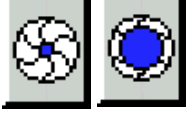

**Note:** The OSD is supposed to be used in a large projection size with a projector or the like.  
If the OSD is used on monitor or a TV, the display may not be clearly seen.

## ○ OSD menu

The main menu items can be set also from the front operation panel of the main body or the remote control.



Icon	Name	Function
	Lighting unit ON/OFF	To turn ON/OFF the upper lighting unit. When the OSD menu is displayed for the first time, the previous setting is maintained. Each time this icon is clicked with the left button of the mouse, the lighting unit is switched in order of two lamps → one lamp (left) → OFF.
	Color/B&W selection	To switch the color/B&W setting. When the OSD menu is displayed for the first time, the screen is in the color setting. When this icon is clicked with the left button of the mouse, the icon changes and the color setting is switched to the B&W setting.
	Pause	To switch the Still/Live setting. When the OSD menu is displayed for the first time, the screen is in the moving setting. When this icon is clicked with the left button of the mouse, the icon changes and the Live setting is switched to the still setting. <b>Note:</b> Clicking the other icons for each function (except Pointer) also cancels the pause mode.
	Auto focus	The object is automatically brought in focus. When this icon is clicked with the left button of the mouse, the auto focus is activated.
	Zoom TELE/WIDE	The image size is adjusted. When this icon is held down with the mouse, the zoom lens is activated.
	Focus NEAR/FAR	The focus is adjusted. When this icon is held down with the mouse, the focus is activated.
	Iris OPEN/CLOSE	To adjust the auto iris level. When this icon is held down with the mouse, the lens iris is activated.
	Pointer	To change the color and shape of the pointer on the screen. Each time this icon is clicked with the left button of the mouse, the pointer color changes in order of white → red → green → blue.

Icon	Name	Function
	White balance	One-push white balance or manual white balance can be selected.
	One push	To set the one-push white balance. When the left button of the mouse is clicked, the white balance of the color temperature is fixed.
 	Manual	<p>To set the white balance by turning the knob  <b>&lt;RED&gt;/&lt;GREEN&gt;/&lt;BLUE&gt;</b>.</p> <p>Click the direction buttons to adjust the white balance with the left button of the mouse.</p> <p><b>&lt;RED&gt;</b> .....To adjust the red component. (-31 ~ +31)  <b>&lt;GREEN&gt;</b> .....To adjust the green component. (-31 ~ +31)  <b>&lt;BLUE&gt;</b> .....To adjust the blue component. (-31 ~ +31)</p>
	Aperture selection ON/OFF	The image enhancer (contour) is switched. When the OSD menu is displayed for the first time, the image enhancer setting is maintained. The aperture has been set to ON before factory-shipment.
	Gamma selection ON/OFF	The gamma selection (0.6/1.0) is switched. When the OSD menu is displayed for the first time, the gamma selection setting is maintained. The gamma has been set to OFF (1.0) before factory-shipment.
	Status saving	The present status and adjusted values are saved. The status of lighting unit ON/OFF, aperture, gamma and the gain values of <RED>, <GREEN> and <BLUE> of manual white balance, auto iris level are saved.
	Initialization	The adjusted values are reset to the values set before factory-shipment.



# 9. COMMUNICATION THROUGH RS-232C

The Visual Presenter can be controlled by a connected PC through the RS-232C terminal **[RS-232C]**.

## ○ Setting up

- (1) Connect the Presenter to a PC with an RS-232C connection cable.

Here, set the **[D]** key of the In/Out selector switch to **[1]**.

**Note:** When using an RS-232C cable available in the market, make sure of the connection shown below.

**Note:** To protect the Presenter and the PC, be sure to turn OFF all the power switches of all equipment before connecting.

- (2) Start the PC, and set the communication mode of the RS-232C to the communication mode of the Presenter.

**Note:** For the information how to set the communication mode of the RS-232C, refer to the instruction manual of the PC.

- (3) Start the PC program to operate the Presenter.

- (4) Control through the RS-232C will start.

**Note:** For communication control, be sure to take the above steps for setting.

**Note:** If the RS-232C cable is not correctly connected between the Presenter and the PC, no response is transmitted. Connect the RS-232C cable correctly, and fix it firmly with the connector set screws before the operation.

## ○ Cable connection

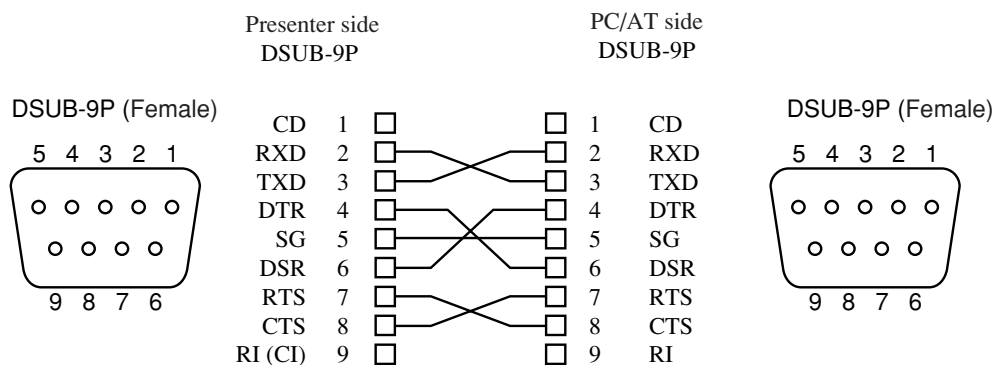



## ○ Transmission specifications

- Full duplex start-stop sync. mode
- Start bit : 1 bit
- Data bit : 8 bits
- Stop bit : 1 bit
- Parity bit : None
- X parameter : None
- Baud rate (Communication speed) : 9600bps

## ○ Table of the communication commands

Function	Command	Parameter	Data	Comments
Auto Focus	AF	0	■ ■	Command to execute the one-shot auto focus.
Auto White Balance	AW	0	■ ■	Command to execute the one-push auto white balance.
Focus adjustment	FO	+ (NEAR) - (FAR) 0 (STOP)	■ ■	Command to adjust the focus.
Zoom adjustment	ZO	+ (TELE) - (WIDE) 0 (STOP)	■ ■	Command to adjust the Zoom.
Iris adjustment	IR	+ (OPEN) - (CLOSE) 0 (STOP) 1 (NORMAL)	■ ■	Command to adjust the Iris.
Lighting selection	PL	0 (OFF) 1 (1 lamp) 2 (2 lamps)	■ ■	Command to select the Lighting.
Color/B&W selection	CB	0 (COLOR) 1 (B&W)	■ ■	Command to select Color/B&W.
Input selection	AV	0 (MAIN) 1 (RGB1)	■ ■	Command to select the Input.
Pointer display	PO	0 (OFF) 1 (ON)	■ ■	Command to turn ON/OFF the Pointer display.
Pointer movement	PM	0 (STOP) 1 (→) 2 (←) 3 (↑) 4 (↓) 5 (↗) 6 (↖) 7 (↘) 8 (↙)	■ ■	Command to move the video pointer. 1: To the right side 2: To the left side 3: To the upper side 4: To the lower side 5: To the upper right 6: To the upper left 7: To the lower right 8: To the lower left

Function	Command	Parameter	Data	Comments
Pause	FZ	0 (OFF) 1 (ON)	■■■	Command to pause the image.
Local lockout	LL	0 (OFF) 1 (ON)	■■■	Command to invalidate the switches on the front operation panel and wireless remote control.
Gamma selection	GM	0 (1.0) 1 (0.6)	■■■	Command to switch the gamma setting value of the image.
Aperture selection	AP	0 (OFF) 1 (ON)	■■■	Command to switch the sharpness (edge effect) of the image.
Default	DF	0	■■■	Command to reset to the initialized mode.
Status request	QS	0 2	■■■	Command to inquire the status of the equipment.
ROM version	QR	0	■■■	Command to refer to the ROM version.
Acknowledge check	SA	0 (OFF) 1 (ON)	■■■	Command to select the command acknowledge for each operation command. (Default :ON)
Add CR command	SC	0 (OFF) 1 (ON)	■■■	Command to add CR [0Dh] to the end of the acknowledge data. (Default :OFF)

**Note:** "■■■" in the data column means that SPACE [20H] should be transmitted twice.

## 10. TROUBLESHOOTING HINTS

Symptom	Possible cause/countermeasure
No image on the screen	<ul style="list-style-type: none"> <li>• Cable is not properly connected to the video-in terminal of monitor.</li> <li>• The power cord is disconnected from the wall AC outlet.</li> <li>• The plug is disconnected from the power cord receptacle of the Presenter.</li> <li>• The power switch is not turned ON.</li> <li>• Zoom is set at TELE to display only white/black part of the material.</li> <li>• The switch is turned ON immediately after it is turned OFF. In this case, the Presenter may not start. Wait several seconds after turning OFF the power switch, and then turn ON the power switch.</li> <li>• The In/Out selector switch is not correctly selected according to connected equipment (See P. 8 and 13).</li> </ul>
Out of focus	<ul style="list-style-type: none"> <li>• The object is too close to the lens. Check if it does not stand higher than 15 cm (5.9 in.) above the stage surface.</li> <li>• Zoom is set at TELE after focusing at WIDE angle. Focus on the point of max. TELE.</li> <li>• In the auto focus, focusing is difficult in some cases.</li> </ul>
The lamp is not quickly turned ON.	<ul style="list-style-type: none"> <li>• For protection purposes, the lamp is turned ON after preheating for 2 seconds. This is not a fault.</li> </ul>
Image is too dark.	<ul style="list-style-type: none"> <li>• The ambient light is not sufficient. Press the lighting unit button <b>[LAMP]</b> to turn ON the upper lamp.</li> </ul>
The image of printed matter is striped.	<ul style="list-style-type: none"> <li>• This is caused by the interference between the dots of printed matter and the scanning line.</li> </ul>
The image flickers	<ul style="list-style-type: none"> <li>• The light from the discharge tube (50Hz) does not come to the screen. This may be reduced by setting the <b>[C]</b> key of the In/Out selector switch to <b>[1]</b> (50Hz) (See P. 8).</li> </ul>

If the trouble still remains after checking the above, consult your dealer or an authorized ELMO service center.

# 11. SPECIFICATIONS

## ● General

Item	Specifications		
Power source	AC120V 60Hz		
Rated current	0.5A		
Outside dimensions	500mm(W) X 612mm(D) X 99mm(H) (19.8 X 24.1 X 3.9 in.) - When folded 706mm(W) X 403mm(D) X 575mm(H) (27.8 X 15.9 X 22.6 in.) - When set up		
Weight	6.5 kgs (14.3 lbs) (main body only)		
Output terminal	Composite-video output	RCA pin jack/75Ω unbalanced	1
	RGB out	Mini DSUB 15P connector (female)	1
	S-video output	Mini DIN 4P connector/75Ω unbalanced	1
Input terminal	RGB in	Mini DSUB 15P connector (female)	1
Ext. control terminal	RS-232C	DSUB 9P connector (male)	1
	USB	Type B receptacle	1

## ● Camera

Item	Specifications		
Lens	f=5.8-58mm (10-time zoom) F2.8		
Zoom	Optical 10-time powered zoom with 2x speed		
Shooting area	340mm x 252mm (13.4 X 9.9 in.) max., 37mm x 28mm (1.5 X 1.1 in.) min.		
Limit of focus adjustment	At the range of stage surface~150mm (5.9 in.) from the stage surface. 0.5m (20 in.)~∞ (with the camera facing sideways and with no close-up lens).		
Focusing	Auto / Manual		
Iris	Auto (with level adjustment) / Manual		
Image pick-up element	1/3" CCD		
Effective picture element	1024 (H) x 768 (V)		
Total picture elements	1077 (H) x 788 (V) (approx. 850,000 pixels)		
Image signal processing	Digital signal processing (DSP)		
Sync. system	Internal		
RGB output resolution	More than 600 TV lines (Horizontal) More than 600 TV lines (Vertical)		
S/N ratio	48 dB		
Output signal	RGB output	Signal frequency XGA Horizontal frequency 48.363kHz Vertical frequency 60.004Hz (1024 x 768 @60Hz) VESA conformable	
	Interlace RGB output	NTSC Horizontal frequency 15.734kHz Vertical frequency 59.940Hz PAL Horizontal frequency 15.625kHz Vertical frequency 50.000Hz	
	Composite-video output	NTSC/PAL Conformable	
	S-video output	NTSC/PAL Conformable	
White balance	Auto / One-push / Manual		
Electronic shutter speed selection	Provided		
Color/B&W selection	Provided		

● **Lighting**

Item	Specifications
Lighting	High frequency lighting mode (Model:FPL9EX-N)

● **Supplied accessories**

Name	Quantity
Power cord	1
RCA video cable	1
Analog RGB cable (BNC connector)	1
VGA cable (Mini DSUB 15P connector)	1
Mouse	1
CD-ROM "Image Mate for HV-400XG/3000XG/3500XG" (PC link software)	1
USB cable	1
Installation manual for CD-ROM "Image Mate for HV-400XG/3000XG/3500XG"	1
Infrared wireless remote controller (RCW-432)	1
Batteries (Type R03, AAA)	2
Instruction manual	1
Warranty card	1
S-video cable (Mini DIN 4P connector)	1

**Note:** The specifications are subject to change without notice.  
Dimensions and weight are approximate.

**Trademark Acknowledgements**

XGA is a registered trademark of International Business Machines.

VESA is a registered trademark of Video Electronics Standards Association.

**ELMO**, ELMO are registered trademarks of ELMO CO.,Ltd.

**WARNING:**

- Unauthorized recording of copyrighted slide films, materials, photographs, etc. may infringe on the rights of copyright owners and be contrary to copyright laws.



**ELMO CO., LTD.**

6-14, Meizen-cho, Mizuho-ku,  
Nagoya, 467-8567, Japan

**OVERSEAS SUBSIDIARY COMPANIES**

- |                |  |
|----------------|--|
| <b>U.S.A.</b>  | <b>ELMO Mfg. Corp.</b><br>1478 Old Country Road, Plainview, NY 11803-5034<br>Tel:(516)501-1400 Fax:(516)501-0429<br>E-mail:elmo@elmousa.com<br>web:http://www.elmousa.com/         |
| <b>Canada</b>  | <b>ELMO Canada Mfg. Corp.</b><br>44 West Drive, Brampton, Ontario L6T 3T6<br>Tel:(905)453-7880 Fax:(905)453-2391<br>E-mail : info@elmocanada.com<br>web:http://www.elmocanada.com/ |
| <b>Germany</b> | <b>ELMO (Europe) G.m.b.H</b><br>Neanderstr. 18, 40233 Düsseldorf<br>Tel : (0211)376051 Fax : (0211)376630<br>E-mail : elmoeurope@AOL.com<br>web : http://www.elmo.de/              |