

## Introduction

This wiring & installation guide provides basic instructions for common Proximity BUS Reader installation scenarios.

**CAUTION!** It is important that you read, understand, and follow the instructions in this document. If you have questions, call your local VT support representative.

## Product Description

The Elpas Proximity BUS Reader is a 125KHz, EM4100 compatible; indoor/outdoor surface mounted proximity reader. The reader features low power consumption, high reliability, and consistent read ranges (up to 10cm / 4 inches), regardless of card or tag.

Designed for harsh indoor/outdoor environments, the reader's solid state electronics is housed in an epoxy potted, IP-67 rated, weatherproof thermoplastic casing that ensures years of maintenance free deployments.

The Proximity BUS Reader contains an onboard I/O that enables the monitoring of one alarm sensor and control of one digital open-collector output. The proximity reader also includes a 2m/6.5ft long RS-485 power/data cable for interfacing to a Elpas BUS Master (a RF IP Reader or an ELC Controller) via a RS-485 Junction Box (P/N:5-JBA00485).

**Note:** An Elpas RS-485 BUS may contain up to fifteen Elpas BUS devices (such as RF or IR Readers, Elpas Display Panels, LF Exciters, or other Proximity BUS Readers) which are wired together using Elpas RS-485 Junction Boxes.

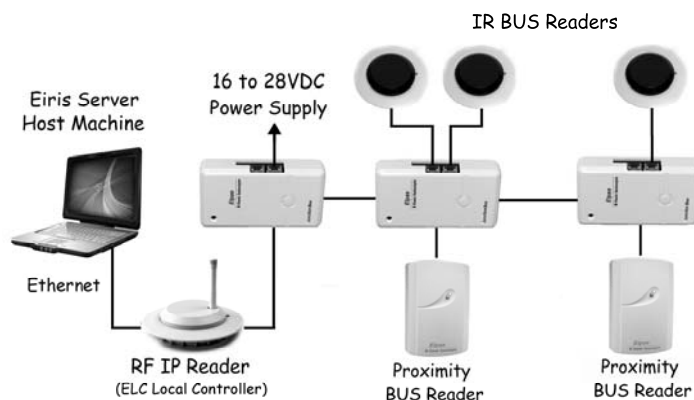

LF Proximity BUS Reader - Network Topology

## Mounting Considerations

The Proximity BUS Reader should be wall mounted, adjacent to the opening side of the door (outside of the protected area), at a height of approximately 1.2m/4ft above the floor

**Note:** When installing Proximity BUS Readers on adjacent doors, make certain that the minimum distance between readers is at least 60cm/2.0ft to ensure proper operation.

## Mounting Procedure

1. Insert a screwdriver into the recess at the bottom of the case, and separate the cover from the reader.
2. Place the base on the installation surface, mark two screw holes, drill the holes, and insert the supplied plastic anchors, if necessary.
3. Fasten the base to the mounting surface, using the two #6 Tap screws supplied with the reader.
4. Replace the reader's cover, ensuring that the cover is aligned with the reader. This enables the LED to be visible.

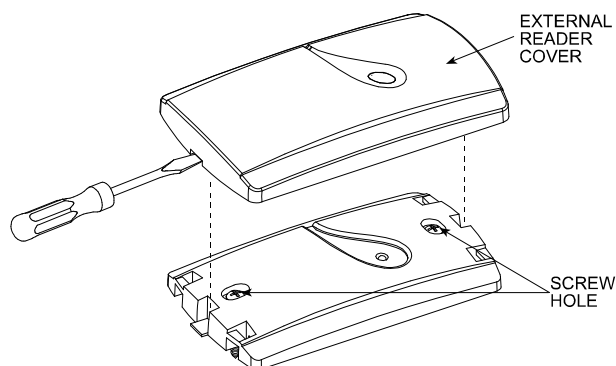

**Note:** Do not install the Proximity BUS Reader directly onto a metal surface, since this can significantly decrease the effective read range of the device. If you have to mount the reader onto a metal surface, insert a RDR-BACK (P/N: 3-6317-0) between the device's reader base and the metal surface.

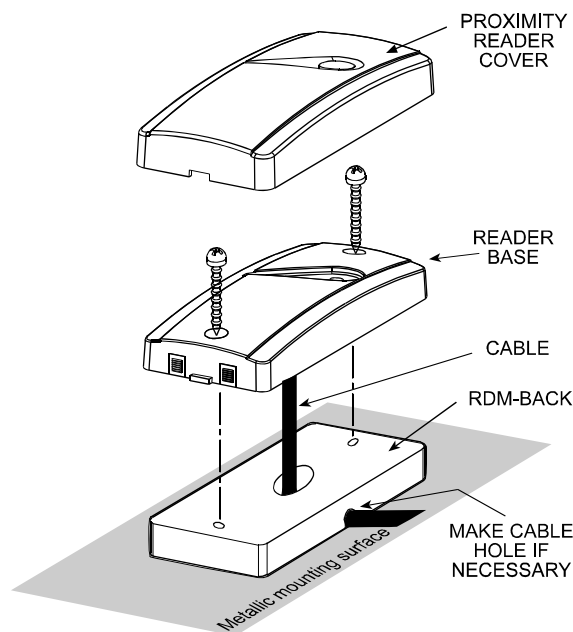

## LED Status Indicator

The Proximity BUS Reader contains a tri-colored (Red, Green and Orange) software configurable LED array that can be used to specify the status of the device.

Refer to the Eiris Software (V4.7.1 or higher) or the ELC Programmer Software (V2.1 or higher) Configuration Guides for setup details.

By default, the Red LED is used to indicate the following device trouble conditions:

- The reader is unregistered (flashes once/sec.)
- The reader has lost RS-485 communication (flashes once/sec.)

## RS-485 Interface

The Proximity BUS Reader has one 2m/6.5ft, 6-wire AWG-26 power/data cable with a male RJ-11 connector (6P6C) for connecting to the RS-485 Junction Box.

## I/O Interface

The Proximity BUS Reader also has a 2m/6.5ft, 4-wire AWG-22 cable with ends for connecting two inputs and one digital output.

Color	Conductor Details
Black	Ground
Red	Digital Output
Green	Input 1 (IN1)
White	Input 2 (IN2)

**IMPORTANT:** BUS Exciters MUST BE powered-down while wiring the unit's I/Os and when connecting to the RS-485 BUS. This will prevent accidental shorts/spikes to cause damage to the devices.

## General Purpose Inputs

The Proximity BUS Reader have two general purpose inputs designated IN1 and IN2. EOL supervision may be added to either of these inputs to detect: Open, Close, Line Cut and Line Short conditions using an End-of-Line Terminator (P/N: 5-IOX00001).

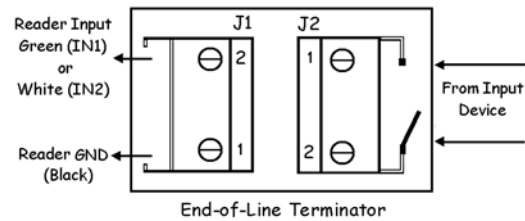

**Recommended Cable:** 22 AWG, unshielded/twisted pair.

## Digital Output

The Proximity BUS Reader has one general purpose digital output, which provides open-collector switching (up to 100mA, 28VDC).

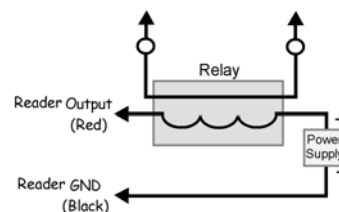

**Recommended Cable:** 22 AWG, unshielded/twisted pair.

## RS-485 BUS/Stub Topology

The RS-485 BUS **MUST BE** wired using a BUS/Stub topology where the BUS Master (a RF IP Reader or an ELC Controller) is connected anywhere along the BUS. The topology supports data transmission between the BUS Master and up to 15 Elpas BUS Devices (such as RF or IR Readers; LF Exciters primary & secondary), Elpas Display Panels and 6x6 I/O Modules using Elpas RS-485 Junction Boxes (P/N: 5-JBA00485).

**IMPORTANT NOTE:** Only 1 RF IP Reader/ELC Controller and up to 7 RF BUS Readers may coexist together on a single BUS.

200M/650Ft: Max. BUS length    10M/30Ft: Max. Stub length    100 Ohm Termination: Required each end of the BUS.

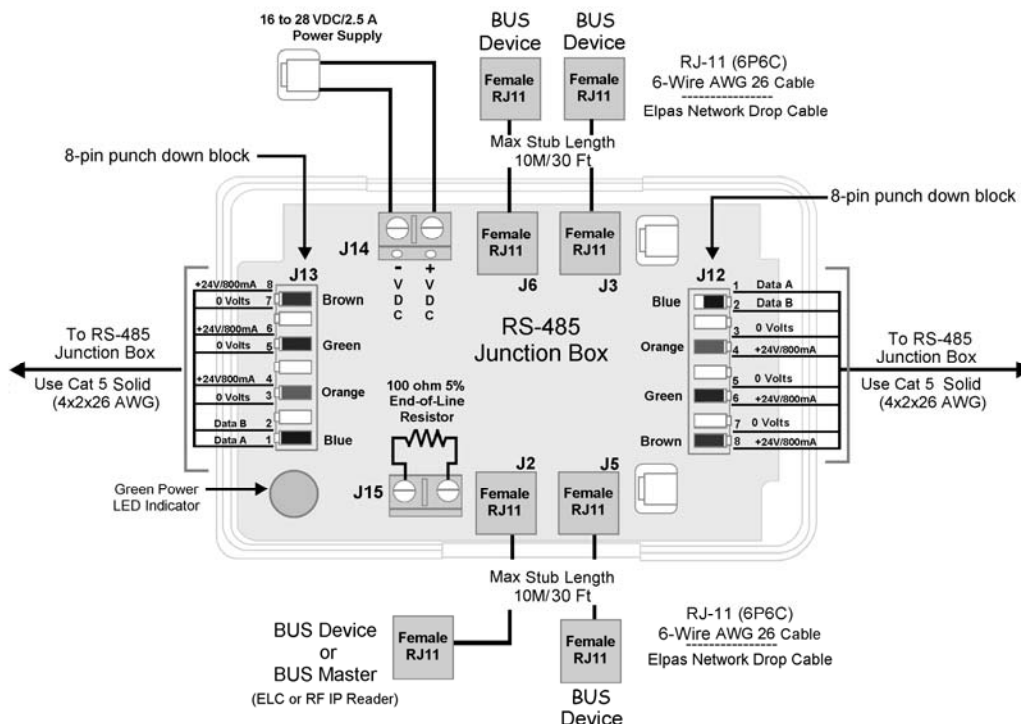

**Recommended RS-485 Backbone Cable Type:** CAT5 Solid (4x2x26AWG)

**For Power:** Use three-twisted pairs (six conductors) between RS-485 Junction Boxes

**For Data:** Use one-twisted pair (two conductors) between RS-485 Junction Boxes

### Standards Compliance

This device complies with Part 15 of the FCC Rules and RSS-210 of Industry and Science Canada. Operation is subject to the following two conditions: (1) This device may not cause harmful interference, and (2) this device must accept any interference received, including interference that may cause undesired operation.

This device complies with Industry Canada license-exempt RSS standard(s). Operation is subject to the following two conditions: (1) this device may not cause interference, and (2) this device must accept any interference, including interference that may cause undesired operation of the device.

Le présent appareil est conforme aux CNR d'Industrie Canada applicables aux appareils radio exempts de licence. L'exploitation est autorisée aux deux conditions suivantes : (1) l'appareil ne doit pas produire de brouillage, et (2) l'utilisateur de l'appareil doit accepter tout brouillage radioélectrique subi, même si le brouillage est susceptible d'en compromettre le fonctionnement.

#### Warning!

Visonic Technologies is not responsible for any radio or TV interference caused by unauthorized modifications to this equipment. Such modifications could void the user's authority to operate the equipment.

### Product Warranty

Visonic Technologies Ltd. (VT or the Company), and its affiliates, warrants its products (hereinafter referred to as "the Product") to be free of defects in materials and workmanship under normal operating conditions and use for a period of one year from the date of shipment by VT. The Company's obligations shall be limited within the warranty period, at its option, to repair or to replace the defective Product or any defective component or part thereof. To exercise this warranty, the product must be returned to the manufacturer freight prepaid and insured.

This warranty does not apply to repairs or replacement caused by improper installation, Product misuse, failure to follow installation or operating instructions, alteration, abuse, accident, tampering, repair by anyone other than VT, external causes, and failure to perform required preventive maintenance. This warranty also does not apply to any products, accessories, or attachments used in conjunction with the Product, including batteries, which shall be covered solely by their own warranties, if any. VT shall not be liable for any damage or loss whatsoever, whether directly, indirectly, incidentally, consequentially or otherwise, resulting from a malfunction of the Product due to products, accessories, or attachments of others, including batteries, used in conjunction with the Product.

VT MAKES NO EXPRESS WARRANTIES EXCEPT THOSE STATED IN THIS STATEMENT. VT DISCLAIMS ALL OTHER WARRANTIES, EXPRESS OR IMPLIED, INCLUDING WITHOUT LIMITATION IMPLIED WARRANTIES OF MERCHANTABILITY AND FITNESS FOR A PARTICULAR PURPOSE. VT'S SOLE RESPONSIBILITY FOR WARRANTY CLAIMS IS LIMITED TO REPAIR OR TO REPLACE AS SET FORTH IN THIS STATEMENT.

VT shall have no liability for any death, personal injury, property damage, or other loss whether direct, indirect, incidental, consequential, or otherwise, based on a claim that the Product failed to function. However, if VT is held liable, whether directly or indirectly, for any loss or damage arising under this limited warranty or otherwise, regardless of cause or origin, VT's maximum liability shall be limited to the purchase price of the Product, which shall be fixed as liquidated damages and not as a penalty, and shall be the complete and exclusive liability of VT.

VT shall not, under any circumstances whatsoever, be liable for any inaccuracy, error of judgment, default, or negligence of VT, its employees, officers, agents, or any other party, or of the purchaser or user, arising from any assistance or communication of any kind regarding the configuration, design, installation, or creation of security system involving the Product, that being the responsibility of the purchaser or user.

If VT is unable to make such repair or replacement, VT's entire liability shall be limited to the cost of a reasonable substitute product. VT shall not be responsible for any dismantling, installation, reinstallation, purchasing, shipping, insurance, or any similar charges.

VT shall have no liability for any damages, including without limitation, any direct, indirect, incidental, special, or consequential damages, expenses, costs, profits, lost savings or earnings, or other damages arising out of the use of the Product or the removal, installation, reinstallation, repair or replacement of the Product or any related events. In the event that there is any liability against VT, such liability shall be limited to the purchase price of the Product which amount shall be fixed as liquidated damages.

The purchaser and user understand that this Product may be compromised or circumvented by intentional acts; that the Product will not in all cases prevent death, personal injury, property damage, or other loss resulting from burglary, robbery, fire or other causes; and that the Product will not in all cases provide adequate warning or protection. The purchaser and user also understand that a properly installed and maintained alarm may reduce the risk of events such as burglary, robbery, and fire without warning, but it is not insurance or a guarantee that such events will not occur or that there will be no death, personal injury, property damage, or other loss as a result of such events.

By purchasing the Product, the purchaser and user shall defend, indemnify and hold VT, its officers, directors, affiliates, subsidiaries, agents, servants, employees, and authorized representatives harmless from and against any and all claims, suits, costs, damages, and judgments incurred, claimed, or sustained whether for death, personal injury, property damage, or otherwise, because of or in any way related to the configuration, design, installation, or creation of a security system involving the Product, and the use, sale, distribution, and installation of the Product, including payment of any and all attorney's fees, costs, and expenses incurred as a result of any such events.

The purchaser or user should follow the Product installation and operation instructions and test the Product and the entire system at least once each week. For various reasons, including but not limited to changes in environmental conditions, electric, electronic, or electromagnetic disruptions, and tampering, the Product may not perform as expected. The purchaser and user are advised to take all necessary precautions for the protection and safety of persons and property.

This statement provides certain legal rights. Other rights may vary by state or country. Under certain circumstances, some states or countries may not allow exclusion or limitation of incidental or consequential damages or implied warranties, so the above exclusions may not apply under those circumstances and in those states or countries.

VT reserves the right to modify this statement at any time, in its sole discretion without notice to any purchaser or user. However, this statement shall not be modified or varied except by VT in writing, and VT does not authorize any single individual to act on its behalf to modify or vary this statement.

Any questions about this statement should be directed to VT. 3/0



#### W.E.E.E. Product Recycling Declaration

For information regarding the recycling of this product you must contact the company from which you originally purchased it. If you are discarding this product and not returning it for repair then you must ensure that it is returned as identified by your supplier. This product is not to be thrown away with everyday waste. Directive 2002/96/EC Waste Electrical and Electronic Equipment.