



America

Certification Exhibit

FCC ID: QZC-MNICI

FCC Rule Part: 15.247

TÜV SÜD Project Number: 72124703

Manufacturer: Elster Solutions
Model: MNICI

Manual

A3 ALPHA[®] with SynergyNet[®] communications

For use with the SynergyNet NIC option board

IL42-4047A

GENERAL

This leaflet provides general information for the SynergyNet network interface card communication (NIC) option for the A3 ALPHA meter. For information on installing the A3 ALPHA meter, see the ALPHA meter installation instructions (IL42-4001S or later).

The A3 ALPHA meter may be ordered with the SynergyNet NIC option board, which provides 900 MHz ISM band communications. Additional hardware configurations may include either a relay option board or an interrupter control board for standard ALPHA meters.

Typically, the internal antenna used with the SynergyNet NIC option board is sufficient for reliable communication with the SynergyNet network. However, if the A3 ALPHA meter is enclosed in a metal service cabinet or the antenna needs to be mounted higher to increase communication distances, an external antenna may be used.

This leaflet contains general information for installing the A3 ALPHA meter equipped with connections for an external antenna.

For information on the operation of the A3 ALPHA meter, see the A3 ALPHA meter technical manual (TM42-2190C or later) or the A3 ALPHA meter technical manual for use in Canada (TM42-2195C or later).

WARNING

Use authorized utility procedures to install and service metering equipment. Dangerous voltages are present. Equipment damage, personal injury, or death can result if safety precautions are not followed.

Use circuit closing devices on current transformer secondaries (3S, 4S, 5S, 5A, 6S, 6A, 8S, 9S, 10S, 10A, 26S, 29S, 35S, 36S, and 36A meters). Equipment damage, personal injury, or death can result if circuit closing secondaries are not used.

LOCATION OF ANTENNAS

See Figure 1 for the location of the SynergyNet NIC internal antenna.

The SynergyNet NIC internal antenna is fix-mounted to the periphery of the A3 ALPHA meter's electronic housing. The SynergyNet NIC antenna is not adjustable or removable.

Alternatively, A3 ALPHA meters may be ordered with an external SynergyNet NIC antenna. With this option, the meter is shipped with an RF "pigtail" output cable which allows connection to an antenna external to the meter. This is advantageous in locations with lower signal strength.

Figure 1. Location of internal antenna

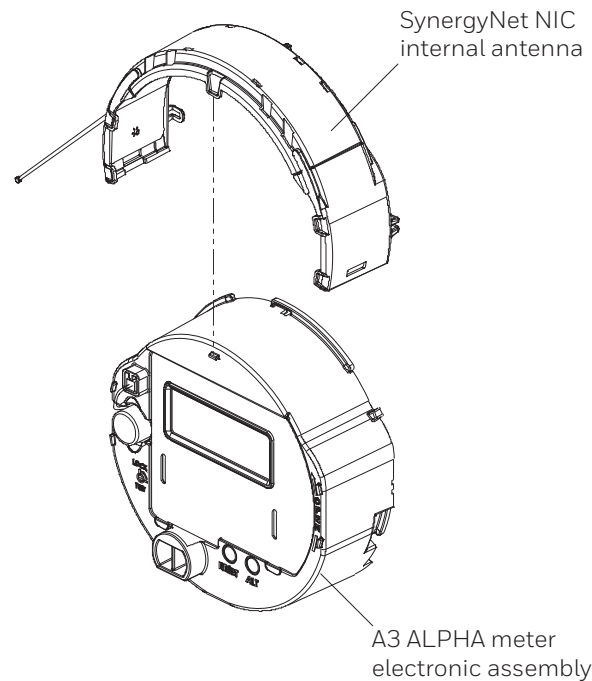

CONNECTING AN EXTERNAL ANTENNA

NOTICE

Installation of an external antenna must be performed by a utility company professional meter installer or contract personnel hired by the utility company to perform electricity meter installation.

⚠ WARNING

Use approved utility safety procedures while installing the external antenna and meter RF output cable in the meter socket box. Dangerous voltages may be present. Assure that there is sufficient clearance between any line-energized socket part and the exposed metal of the antenna connectors. Also assure that the external antenna is electrically bonded to the meter socket box. Failing to follow approved utility safety procedures, failing to allow sufficient clearance, or failing to electrically bond the external antenna to the meter socket box may result in equipment damage, personal injury, or death.

The A3 ALPHA meter with the SynergyNet NIC option board has been certified for operation with the following antennas. Antennas not included in this list are strictly prohibited for use with this device.

- Internal antenna: Honeywell Smart Energy electricity metering P/N: 1B12150H01
- Local external antennas: Laird/Antenex TRA9023P (3.1 dBi) for use only with metal service cabinets and meter sockets; Laird/Antenex TRA9023NP (3.1 dBi) for use only with non-metal service cabinets
- Remote external antennas: PCTEL/MAXRAD P/N MFB9150 (2.15 dBi); PCTEL/MAXRAD P/N MFB 9153 (5.15 dBi)

The external antenna connects to the SynergyNet NIC option board using a connector lead as shown in Figure 2. There are two options available for connecting an external antenna:

- Local external antenna
- Remote external antenna

Figure 2. Retaining clip and connector lead

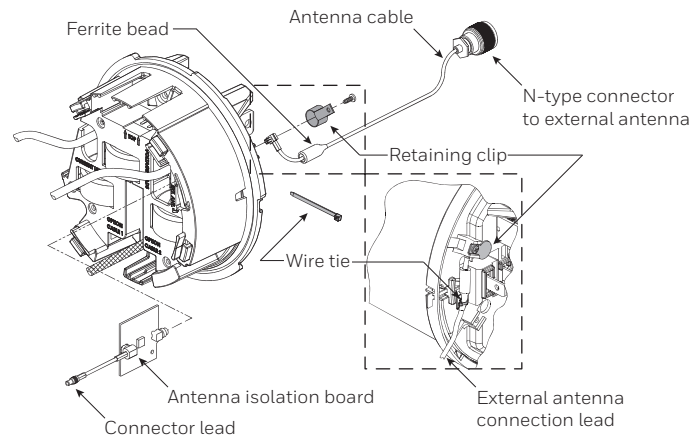

LOCAL EXTERNAL ANTENNA

If the A3 ALPHA meter is used in a metal service cabinet, using a local external antenna may be necessary. To obtain better coverage, the local external antenna can be mounted on the top of the metal service cabinet or the meter socket enclosure (see [1] in Figure 3).

Honeywell Smart Energy recommends the Laird/Antenex 902-928 MHz permanent mount antenna (TRA9023P).

See Figure 3 for the recommended location of the SynergyNet NIC external antenna. Honeywell Smart Energy recommends mounting the external SynergyNet NIC antenna on the top of the meter socket box as shown, centered in the available space on the meter box's top surface.

- Drill a 5/8-inch hole into the cabinet wall with a step drill and/or punch the specified antenna mounting hole in the top of the meter socket box and install the antenna using the antenna manufacturer's instructions.
- Connect the meter's RF "pigtail" output cable directly to the antenna via its integral N-type connector. The SynergyNet NIC antenna output cable may be ordered in two lengths: 19 or 36 inches. Choose the length based on the distance from the meter to the SynergyNet NIC external antenna, which is in turn determined by the size of the meter socket box.

For installations where the mounting of the local antenna does not provide a conductive metallic ground plane, the Antenex TRA9023NP (no ground plane required) may be employed. The gain and pattern are virtually identical with the TRA9023P version. The TRA9023NP antenna may also be employed on metallic ground planes with good results.

REMOTE EXTERNAL ANTENNA

If the A3 ALPHA meter is used in a metal building, or the meter is installed in a location where the site requires an antenna at a greater height, a remote antenna may be used. If a remote external antenna is used, a lightning/surge arrestor should be installed at the bottom of the socket enclosure (see [2] in Figure 3). Honeywell Smart Energy recommends a PolyPhaser DSXL IN-LINE EMP surge filter (Tessco P/N 491574).

NOTICE

Do not use a standard RG-8/U cable with solid polyethylene dielectric. The losses in solid dielectric RG-8/U cables in short distances make solid dielectric RG-8/U cables unacceptable.

The most economical connection to the remote external antenna is the RG-8/U "foam" or "LMR-400" type cable. This type of cable is suitable for distances of up to 100 feet. The foam dielectric cable will incur a loss of approximately 3.9 dB in 100 feet (or approximately 2 dB in 50 feet). The coaxial cable should be mounted at the bottom of the meter socket in "drip loop" fashion. A "drip loop" is formed by bringing the coaxial cable to a point below the meter socket and then bending it back up to the connector. This forms a U-shape, which allows water to run down the cable exterior. Antenna cables should be ordered with N-type male connectors on each end.

The A3 ALPHA meter with the SynergyNet NIC option board has been certified for operation with the following remote external antennas. Both antennas are rated to withstand 100 mph winds and are fitted with Type N female connectors:

- PCTEL/MAXRAD MFB9150 Series (Tessco P/N 39493) for unity gain (2.15 dBi)
- PCTEL/MAXRAD MFB9153 Series (Tessco P/N 74330) for 3 dB gain (5.15 dBi)

Regardless of the antenna selected, the antenna should be mounted with at least two MMK1 pipe clamps (Tessco SKU 68869). The antenna should be mounted in the clear, as free from conductive or metallic obstructions as possible. The connectors should be sealed for waterproofing.

Please note that external antennas must be purchased separately, either from Honeywell Smart Energy or a third party, from a list of approved antennas. Please ask your Honeywell electricity metering sales representative for the current list of approved external antennas.

Figure 3. Location of SynergyNet NIC external antennas

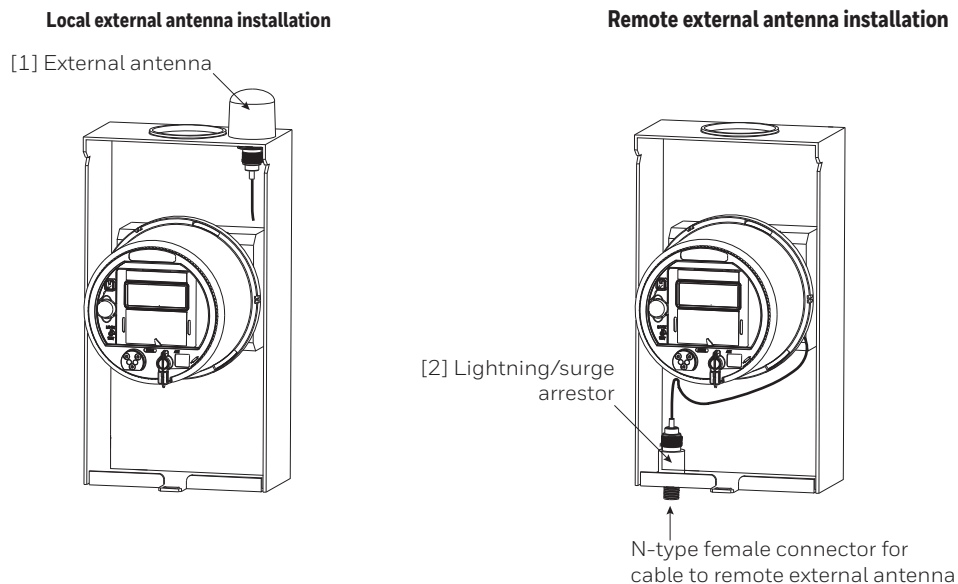

Remote antenna materials described in this IL can be obtained from the following:

Tessco Technologies, Inc.
 11126 McCormick Road
 Hunt Valley, MD 21031-1494
 +1 800 508 5444
 tessco.com

Laird/Antenex antennas can be obtained from the following:

OEM Sales M6
 Laird Technologies
 1751 Wilkening Court
 Schaumburg, IL 60173
 +1 847 839 6916 (telephone) or +1 847 839 6063 (fax)
 www.lairdtech.com

FCC AND ISED CANADA COMPLIANCE

WARNING (PART 15.21)

The A3 ALPHA meter equipped with the SynergyNet NIC option complies with Part 15 of the FCC Rules and with Innovation, Science, and Economic Development (ISED) Canada RSS-210. Warning: Changes or modifications not expressly approved by Honeywell could void the user's authority to operate the equipment.

USER INFORMATION (PART 15.105)

This equipment has been tested and found to comply with the limits for a Class B digital device, pursuant to part 15 of the FCC Rules. These limits are designed to provide reasonable protection against harmful interference in a residential installation. This equipment generates, uses and can radiate radio frequency energy and, if not installed and used in accordance with the instructions, may cause harmful interference to radio communications. However, there is no guarantee that interference will not occur in a particular installation. If this equipment does cause harmful interference to radio or television reception, which can be determined by turning the equipment off and on, the user is encouraged to try to correct the interference by one or more of the following measures:

- reorient or relocate the receiving antenna
- increase the separation between the equipment and the receiver
- connect the equipment into an outlet on a circuit different from that to which the receiver is connected
- consult the dealer or an experienced radio/TV technician for help

If you experience trouble with this equipment, please use the Return Material Request (RMR) feature available at the Online Customer Services at www.elsterelectricity.com. Do not attempt to repair this equipment yourself unless you are replacing the entire module.

COMPLIANCE STATEMENT (PART 15.19)

This device complies with Part 15 of the FCC Rules and Class B digital apparatus requirements for ICES-003. Operation is subject to the following two conditions: (1) This device may not cause harmful interference, and (2) this device must accept any interference received, including interference that may cause undesired operation of the device.

ÉNONCÉ DE CONFORMITÉ

Cet appareil est conforme à la Partie 15 des règles de la FCC et aux CNR d'Industrie Canada applicables aux appareils radio exempts de licence. L'utilisation de cet appareil est soumise aux deux conditions suivantes : (1) Cet appareil ne doit pas provoquer d'interférences nocives et (2) cet appareil doit accepter toutes les interférences reçues notamment celles pouvant provoquer un fonctionnement intempestif de l'appareil.

ANTENNA COMPLIANCE

Under Industry Canada regulations, this radio transmitter may only operate using an antenna of a type and maximum (or lesser) gain approved for the transmitter by Industry Canada. To reduce potential radio interference to other users, the antenna type and its gain should be so chosen that the Equivalent Isotropic Radiated Power (EIRP) is not more than that necessary for successful communication.

Conformément à la réglementation d'Industrie Canada, le présent émetteur radio peut fonctionner avec une antenne d'un type et d'un gain maximal (ou inférieur) approuvé pour l'émetteur par Industrie Canada. Dans le but de réduire les risques de brouillage radioélectrique à l'intention des autres utilisateurs, il faut choisir le type d'antenne et son gain de sorte que la puissance isotrope rayonnée équivalente (p.i.r.e.) ne dépasse pas l'intensité nécessaire à l'établissement d'une communication satisfaisante.

SynergyNet NIC: This radio transmitter has been approved by Industry Canada to operate with the antenna types listed below with the maximum permissible gain indicated. Antenna types not included in this list, having a gain greater than the maximum gain indicated for that type, are strictly prohibited for use with this device.

SynergyNet NIC: Le présent émetteur radio a été approuvé par Industrie Canada pour fonctionner avec les types d'antenne énumérés ci-dessous et ayant un gain admissible maximal et l'impédance requise pour chaque type d'antenne. Les types d'antenne non inclus dans cette liste, ou dont le gain est supérieur au gain maximal indiqué, sont strictement interdits pour l'exploitation de l'émetteur.

- Honeywell (1B12150H01): 3.49 dBi
- Laird/Antenex TRA9023P(NP) (white body) or TRAB9023P(NP) (black body): 3 dBi
- PCTEL/MAXRAD MFB9150 unity gain Fiberglass omnidirectional: 2.15 dBi
- PCTEL/MAXRAD MFB9153 3 dB Fiberglass omnidirectional: 5.15 dBi

This device complies with Industry Canada's licence-exempt RSSs. Operation is subject to the following two conditions:

(1) This device may not cause interference; and

(2) This device must accept any interference, including interference that may cause undesired operation of the device.

Le présent appareil est conforme aux CNR d'Industrie Canada applicables aux appareils radio exempts de licence. L'exploitation est autorisée aux deux conditions suivantes: (1) l'appareil ne doit pas produire de brouillage, et (2) l'utilisateur de l'appareil doit accepter tout brouillage radioélectrique subi, même si le brouillage est susceptible d'en compromettre le fonctionnement.

RF RADIATION SAFETY GUIDELINES

This equipment complies with radiation exposure limits set forth for an uncontrolled environment. This equipment should be installed and operated with minimum distance 31 cm between the radiator and your body. This transmitter must not be co-located or operating in conjunction with any other antenna or transmitter.

DIRECTIVES DE SÉCURITÉ DE RADIOFRÉQUENCE

Cet équipement est conforme aux limites d'exposition aux radiations dans un environnement non contrôlé. Cet équipement doit être installé et utilisé à distance minimum de 31 cm entre le radiateur et votre corps. Cet émetteur ne doit pas être co-localisées ou opérant en conjonction avec tout autre antenne ou transmetteur.

COLLOCATION STATEMENT

Collocation of simultaneously-transmitting (co-transmitting) antennas located within a final product is not allowed, except as documented in the FCC application. Users and installers must be provided with antenna installation instructions and transmitter operating conditions for satisfying RF exposure compliance.

DISCLAIMER OF WARRANTIES AND LIMITATIONS OF LIABILITY

There are no understandings, agreements, representations, or warranties either express or implied, including warranties of merchantability or fitness for a particular purpose, other than those specifically set out by any existing contract between the parties. Any such contract states the entire obligation of the seller. The contents of this document shall not become part of or modify any prior existing agreement, commitment, or relationship.

The information, recommendations, descriptions, and safety notices in this document are based on Elster Solutions, LLC experience and judgment with respect to operation and maintenance of the described product. This information should not be considered as all-inclusive or covering all contingencies. If further information is required, Elster Solutions, LLC should be consulted.

No warranties, either expressed or implied, including warranties of fitness for a particular purpose or merchantability, or warranties arising from the course of dealing or usage of trade, are made regarding the information, recommendations, descriptions, warnings, and cautions contained herein.

In no event will Elster Solutions, LLC be responsible to the user in contract, in tort (including negligence), strict liability or otherwise for any special, indirect, incidental, or consequential damage or loss whatsoever, including but not limited to: damage or loss of use of equipment, cost of capital, loss of profits or revenues, or claims against the user by its customers resulting from the use of the information, recommendations, descriptions, and safety notices contained herein.