



**Product Guide**  
PG42-1005B

# A3 ALPHA<sup>®</sup> Meter/Collector

© 2004 by Elster Electricity, LLC. All rights are reserved.

No part of this software or documentation may be reproduced, transmitted, processed or recorded by any means or form, electronic, mechanical, photographic or otherwise, translated to another language, or be released to any third party without the express written consent of Elster Electricity, LLC.

Printed in the United States of America.

ALPHA, ALPHA Plus, and EnergyAxis are registered trademarks; and Metercat, AlphaPlus, and REX are trademarks of Elster Electricity, LLC.

Other product and company names mentioned herein may be the trademarks and/or registered trademarks of their respective owners.

---

#### **DISCLAIMER OF WARRANTIES AND LIMITATIONS OF LIABILITY**

---

There are no understandings, agreements, representations, or warranties either expressed or implied, including warranties of merchantability or fitness for a particular purpose, other than those specifically set out by any existing contract between the parties. Any such contract states the entire obligation of the seller. The contents of this document shall not become part of or modify any prior existing agreement, commitment, or relationship.

The information, recommendations, descriptions, and safety notices in this document are based on Elster Electricity, LLC experience and judgment with respect to operation and maintenance of the described product. This information should not be considered as all-inclusive or covering all contingencies. If further information is required, Elster Electricity, LLC should be consulted.

---

No warranties, either expressed or implied, including warranties of fitness for a particular purpose or merchantability, or warranties arising from the course of dealing or usage of trade, are made regarding the information, recommendations, descriptions, warnings, and cautions contained herein.

In no event will Elster Electricity, LLC be responsible to the user in contract, in tort (including negligence), strict liability or otherwise for any special, indirect, incidental, or consequential damage or loss whatsoever, including but not limited to: damage or loss of use of equipment, cost of capital, loss of profits or revenues, or claims against the user by its customers resulting from the use of the information, recommendations, descriptions, and safety notices contained herein.

---

**Contents**

**General Description . . . . . 1**

**A3 ALPHA Meter Circuit Board . . . . . 1**

    Metercat Programming Note . . . . . 3

**Metering Software and System . . . . . 3**

    Metercat . . . . . 3

    EnergyAxis Metering Automation Server . . . . . 3

**Operation of the A3 ALPHA Meter with ILC1 Option Board . . . . . 4**

    Billing Date . . . . . 4

    TOU Schedules . . . . . 4

        Calendar . . . . . 5

    Season Changes . . . . . 5

    Call Initiation . . . . . 5

    Power Failure . . . . . 6

    Loss of Real Time . . . . . 6

**Reading the A3 ALPHA Meter/Collector . . . . . 6**

**Changing an A3 ALPHA Meter with ILC1 Option Board . . . . . 7**

**Display List Items . . . . . 7**

**ILC1 Option Board Error Codes . . . . . 8**

        No error . . . . . 8

        Clock error . . . . . 8

        Carryover error . . . . . 9

        Table CRC error . . . . . 9

        General configuration error . . . . . 9

        Shared memory error . . . . . 9

        Power fail data save error . . . . . 9

**ILC1 Option Board Status Codes . . . . . 9**

        Collector operation . . . . . 9

**ILC1 Option Board Information . . . . . 10**

        REX LAN ID 1 . . . . . 10

        REX LAN ID 2 . . . . . 10

        REX utility ID . . . . . 10

        ILC number of nodes . . . . . 10

        ILC number of repeaters . . . . . 10

**Memory Capacity . . . . . 10**

**FCC and Industry Canada Compliance . . . . . 11**

    Compliance Statement (Part 15.19) . . . . . 11

    Warning (Part 15.21) . . . . . 11

    RF Radiation Safety Guidelines per Part 2 of FCC Rules and Regulations . . . . . 11

    User Information (Part 15.105) . . . . . 11

    Industry Canada Statement . . . . . 12

**Technical Specifications . . . . . 12**

    Operating Ranges . . . . . 12



## General Description

The A3 ALPHA meter/collector is the component of the EnergyAxis® System that provides the interface between the Metering Automation Server (MAS) and the local network of REX™ meters that are registered to the meter/collector. MAS communicates with the A3 ALPHA meter/collector using a standard telephone line. The A3 ALPHA meter/collector then communicates with its registered REX meters using a 2-way 900 MHz radio frequency network. The primary task of the internal LAN controller (ILC1) option board is to maintain the local area network (LAN) and read and store billing data from REX meters. The A3 ALPHA meter/collector is responsible for various activities within the network of REX meters, including the following:

- reading and storing the billing data from each REX meter on a periodic basis
- reading and storing the load profiling data from a configurable number of REX meters on a periodic basis
- notifying the REX meters to perform demand resets based on a schedule from MAS
- reading and storing the previous billing period data from REX meters after a demand reset has occurred
- notifying the REX meters to perform season changes based on a schedule from MAS
- reading and storing the previous season data from REX meters after season changes have occurred
- synchronizing the REX meters to the system time and TOU day type
- distributing TOU rate schedules and associated display lists to the REX meters
- reading or sending commands to an individual REX meter on request from MAS
- performing other network maintenance tasks
- reporting the billing and load profiling data back to MAS

## A3 ALPHA Meter Circuit Board

The A3 ALPHA meter builds upon the strengths of the existing ALPHA meter designs. Like its predecessors, the A3 ALPHA meter uses Elster Electricity's patented digital measurement techniques that offer high accuracy, repeatability, and low ownership costs. In support of open architecture standards, the A3 ALPHA meter is the first Elster Electricity meter to fully support ANSI C12.18, C12.19, and C12.21 standards.

To function as a collector, an A3 ALPHA meter requires the following two option boards:

- internal telephone modem (ITM3) with optional outage reporting capabilities
- internal LAN controller (ILC1)

The ITM3 option board connects to the A3 ALPHA meter using the 20-pin header (J4) on the meter circuit board as shown in Figure 1. The ILC1 option board connects to the ITM3 option board using the 20-pin header (J5) as shown in Figure 1.

The antenna for the ILC1 option board mounts directly onto the electronic housing (see Figure 2) and fits completely under the cover of the A3 ALPHA meter.

An A3 ALPHA meter/collector has a 4-conductor telephone cable exiting the meter with an RJ-11 connector at the end as shown in Figure 3. There is a wire marker approximately 6 inches from the RJ-11 end with "INT MOD ITM3" printed on it for identifying that the ITM3 option board is installed.

Figure 1. A3 ALPHA meter electronic assembly

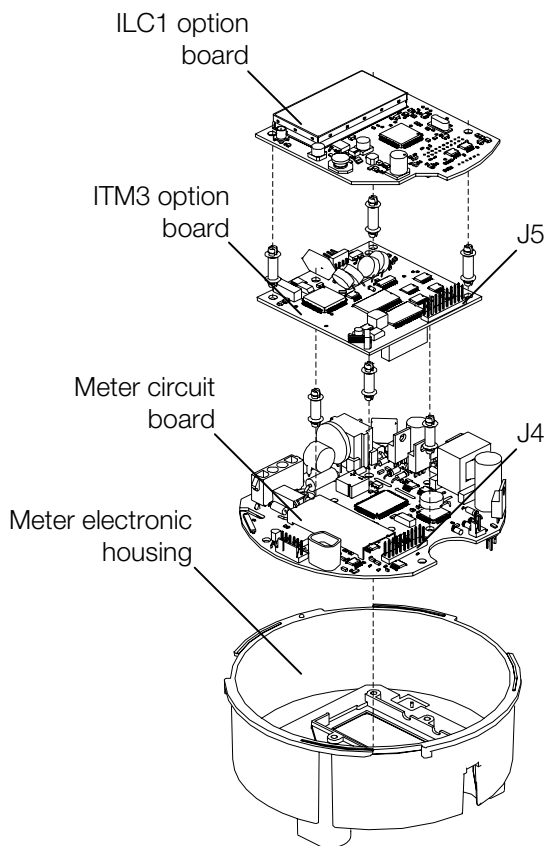

Figure 2. A3 ALPHA electronic housing with antenna

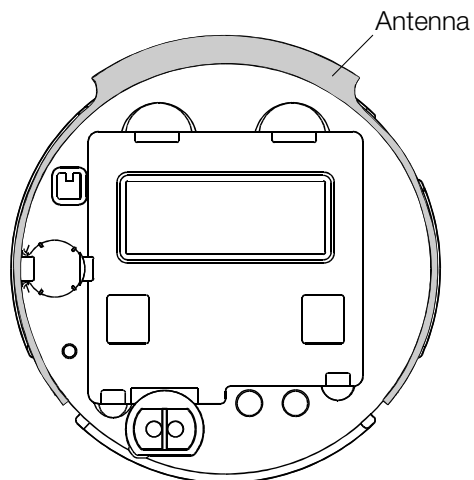
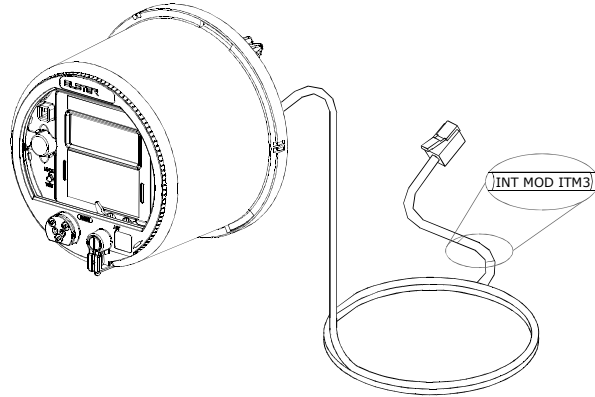

Figure 3. A3 ALPHA meter with ITM3 RJ-11 cable



### Metercat Programming Note

To have the A3 ALPHA meter function properly as a data collector in the EnergyAxis System, it is important that the meter be programmed correctly using Metercat™. In the Remote component tab in Metercat, be sure that the following options are set:

- Port 1 usage is set to internal modem.
- Port 2 usage is set to direct connect.
- On the Port 1 Modem tab, enable line sharing (the Enable Line Sharing box is checked).
- On the Port 2 Direct Connect tab, the bit rate is set to 9600.

The other options can be set as desired. For more information on using Metercat, see the Metercat documentation.

### Metering Software and System

#### Metercat

The A3 ALPHA meter/collector requires Elster Electricity Metercat support software release 1.4 or later. Metercat offers the following features:

- program development to create user-defined configuration data
- meter programming to send user-defined configuration data or commands to the meter
- meter reading to receive data that has been stored by the meter
- diagnostic read including ILC1 option board and LAN status
- ability to perform tasks related to replacing a collector

#### EnergyAxis Metering Automation Server

The EnergyAxis Metering Automation Server (MAS) reads meters over telephone or wireless networks. Using MAS, meter readings can be scheduled or performed on-request from the browser-based user interface. MAS allows all billing data to be read from the meter; this includes data from the A3 ALPHA meter and from each REX meter registered with the ILC1 option board. Billing data from the A3 ALPHA meter includes multi-channel interval data, consumption, demand, time-of-use registers as well as meter status flags. REX meter data can be read from the stored data in the collector or on-request by using MAS to communicate through the collector to the individual REX meter.

## **Operation of the A3 ALPHA Meter with ILC1 Option Board**

Data exchange with MAS is performed using an open XML schema, AMR Data Exchange Format (AMRDEF), so that interfaces with billing systems and other enterprise systems can be easily implemented. MAS also comes with the JSlinger module, a powerful driver for file transfer protocol (FTP) that can transform, compress and encrypt data files prior to sending them to trusted IP addresses across the Internet.

The A3 ALPHA meter and the ILC1 option board typically operate independently of each other. The primary task of the ILC1 option board is to maintain the LAN and read and store billing data from REX meters. The ILC1 option board communicates with the A3 ALPHA meter to read time and day type information. This information is then propagated through the LAN to the REX meters. The time base in the A3 ALPHA meter is used as the system time for the LAN, and the ILC1 option board periodically reads this time and distributes the time to the LAN.

### **Billing Date**

The ILC1 option board handles the billing dates for the REX meters it has registered. Configuration options in the ILC1 option board permit each REX meter to be assigned to one of thirty billing date cycles. The ILC1 option board makes certain that the REX meters perform demand resets on the correct dates using the billing date cycles.

The REX meter stores a copy of the billing data before the demand is reset. This billing data copy can then be read and stored by the ILC1 option board. REX meter billing dates can be controlled by MAS.

For A3 ALPHA meters, the billing date (or, the demand reset date) can be controlled by either of the following:

- by the calendar programmed into the A3 ALPHA meter using Metercat support software
- by MAS when MAS calls the A3 ALPHA meter on the billing date and issues a demand reset command

### **TOU Schedules**

The ILC1 option board stores up to 8 separate meter programs. Each program can support a TOU schedule and has its own associated display list. MAS assigns each registered REX meter to one of the programs and associated display list.

Each TOU schedule for the REX meter consists of weekday, weekend, and two special day types (that is, holidays). The ILC1 option board broadcasts the TOU schedule to the REX meters where the schedules are stored and used to record kWh data in the correct TOU register. The ILC1 option board reads and stores TOU data from each REX meter as part of the normal billing read.

The display list controls the values that are shown on the REX meter LCD. See Appendix B, "Display," of the *REX Meter Technical Manual (TM42-2210)* for information on the values that can be displayed on the REX meter LCD.

Using MAS Release 5.0 and later, users can remotely change the TOU schedules and associated display lists stored in the ILC1 option board. The ILC1 option board verifies the delivery of the TOU schedule and associated display list to each REX meter.



The A3 ALPHA meter uses its own, separate TOU switch points (programmed into the A3 ALPHA meter using Metercat support software) that are independent from the ILC1 option board switch points.

**Calendar.** The ILC1 option board reads the A3 ALPHA meter calendar to determine the day type for the next 32 days and relays this to the REX meters registered to the collector.

### Season Changes

Season changes for the A3 ALPHA meter/collector are controlled by the calendar in the A3 ALPHA meter. Season changes for the REX meters are controlled by calendars in the ILC1 option board. The ILC1 option board has season change dates for each of eight possible TOU schedules. Using the season change information, the ILC1 option board makes certain that the associated REX meter performs a season change on the correct date. After a season change, the ILC1 option board will read and store a season change copy of the billing data from associated REX meters.

### Call Initiation

The A3 ALPHA meter/collector can initiate billing, alarm, and outage/restoration calls based on the customer program configured in the meter (see Metercat documentation or the ITM3 product guide PG42-1006 for more information on call initiation). Additionally, the ILC1 option board can independently initiate alarm calls to report the following conditions:

- an additional REX meter has been registered to this collector
- a REX meter's demand threshold has been exceeded (the REX meter itself must also be enabled to report this condition to the collector)
- power has been restored to a REX meter (the REX meter itself must also be enabled to report this condition to the collector)
- warning conditions related to REX meters with an internal service disconnect switch (the REX meter itself must also be enabled to report this condition to the collector)

For each of these exceptions, the ILC1 option board can be configured to initiate a call at the following times:

- never
- immediately
- after a configurable delay of 1 to 255 minutes
- daily

Telephone calls initiated by the ILC1 option board use the A3 ALPHA meter's settings for alarm calls.

## **Power Failure**

When there is a power failure, the A3 ALPHA meter initiates a shutdown and stores the A3 ALPHA meter billing data and status information in EEPROM. All billing data information stored in the ILC1 option board is stored in battery-backed RAM. The A3 ALPHA meter's real-time clock and the data stored in the ILC1 option board are maintained by the super capacitor and battery during a power failure.

If both the super capacitor and battery fail, all RAM in the meter and in the ILC1 will be lost. Upon subsequent power restoration, an error code is generated for both the A3 ALPHA meter and the ILC1 option board.

- For information on A3 ALPHA meter error codes, see the *A3 ALPHA Meter Technical Manual* (TM42-2190).
- For information on ILC1 option board error codes, see "ILC1 Option Board Error Codes" on page 8.

## **Loss of Real Time**

Within the network, the REX meters obtain real time from time signals sent by the collector. The ILC1 option board does not have its own real time clock; instead, it obtains the time directly from the A3 ALPHA meter. There are two ways the ILC1 option board can lose time from the A3 ALPHA meter:

- A3 ALPHA meter has lost its timekeeping capability
- the ILC1 option board cannot communicate with the A3 ALPHA meter

If the ILC1 option board loses time, the REX meters in the network will continue to keep real time and date for up to 32 days or until the REX meter has a power outage. The REX meters will then revert to relative timekeeping and store all TOU energy data in the default rate.

The A3 ALPHA meter LCD will indicate the ILC1 option board's loss of real time by displaying an error code (see "ILC1 Option Board Error Codes" on page 8 for more information).

## **Reading the A3 ALPHA Meter/Collector**

The A3 ALPHA meter/collector can be read in the following ways:

- visually using the LCD
- optically or remotely using Metercat support software
- remotely via the ITM3 option board using MAS

For more details on the information that can be viewed on the LCD, see "Display List Items" on page 7.

For more details on reading the A3 ALPHA meter/collector optically, see the Metercat documentation and online Help.

For more details on reading the A3 ALPHA meter/collector remotely, see the MAS documentation and online Help.

## Changing an A3 ALPHA Meter with ILC1 Option Board

### ⚠ WARNING

Use authorized utility procedures to remove metering equipment. Dangerous voltages are present. Equipment damage, personal injury, or death can result if safety procedures are not followed.

If the A3 ALPHA meter/collector must be taken out of service (because of an error condition, the telephone modem fails, etc.), the A3 ALPHA meter/collector can be replaced with another A3 ALPHA meter/collector.

Since the REX meters within the network register with a collector, a change out procedure needs to be performed to make certain that the REX meters will communicate with the new A3 ALPHA meter/collector. Follow these steps to change out an old meter/collector with a new meter/collector:

1. Before beginning the change out procedure, verify that the new A3 ALPHA meter/collector is properly configured. See *Metercat Program Development Guide* (TM42-2204) for specific details.
2. Using Metercat software, perform a billing or diagnostic read on the old A3 ALPHA meter/collector. Be certain that Metercat is configured to perform the following:
  - store the reading
  - read all of the internal LAN controller data
3. Make a note of the old A3 ALPHA meter/collector LAN ID obtained from the billing or diagnostic read performed in step 2. The LAN ID is found on the Internal LAN Controller tab of the Status view.
 

**Note.** The LAN ID is also available on the nameplate. See Appendix C, "Nameplate Information," in the *REX Meter Technical Manual* (TM42-2210) for more details.
4. Remove the old A3 ALPHA meter/collector from service. See *A3 ALPHA Meter Technical Manual* (TM42-2190) for specific details.
5. Install the new A3 ALPHA meter/collector. Be sure to follow the instructions that are provided with the A3 ALPHA meter/collector to correctly install the meter/collector.
6. Using Metercat software, perform the "Change Out LAN Collector" task. See *Metercat User Guide* (TM42-2204) for specific details. The old A3 ALPHA meter/collector LAN ID obtained in step 3 will be needed to complete the change out function.

After the change out command is performed, the REX meters previously registered with the old meter/collector will re-register with the new A3 ALPHA meter/collector.

## Display List Items

The A3 ALPHA meter display is divided into different regions as shown in Figure 4. See Chapter 3, "Operating Instructions," in the *A3 ALPHA Meter Technical Manual* (TM42-2190) for more detailed descriptions of the LCD and its display regions.

Figure 4. A3 ALPHA meter LCD

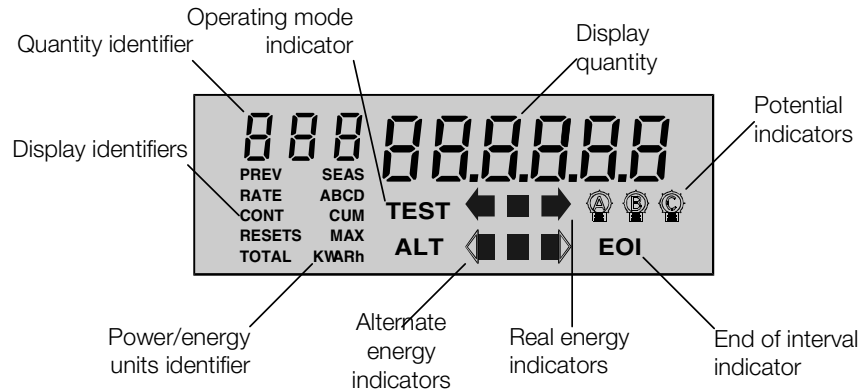

The display list for all displayable items, including the items relating to the ILC1 option board, can be programmed using Metercat meter support software.

### ILC1 Option Board Error Codes

Unlike A3 ALPHA meter error codes, ILC1 option board error codes must be programmed as a displayable item in the A3 ALPHA meter display list using Metercat support software; otherwise, the meter LCD will not display any indication that a condition exists that affects the ILC1 option board's operation. Table 1 identifies the ILC1 option board error conditions and the associated display quantity value. The quantity identifier is the same for all ILC1 option board error codes and can be programmed to be any numeric character (represented by **i** in Table 1).

Table 1. Error conditions and codes

Condition	Quantity identifier	Display quantity value
No error	iii	000000
Clock error	iii	000001
Carryover error	iii	000010
Table CRC error	iii	000100
Configuration error	iii	001000
Shared memory error	iii	010000
Power fail data save error	iii	100000

Error codes may be displayed in combination (for example, **iii 100001**), indicating that more than one error condition has been detected.

**No error.** This code is displayed when no error condition exists in the ILC1 option board. Since ILC1 option board error codes must be programmed as display items, the no error code is used when no error condition is present in the ILC1 option board.

**Clock error.** This code indicates an error with the timekeeping ability of the ILC1 option board. The ILC1 option board can lose its real time clock if the A3 ALPHA meter has lost its timekeeping capability or if the ILC1 option board cannot communicate with the A3 ALPHA meter. When this condition is present,

the ILC1 option board ceases LAN communications (modem communication, however, is still possible) and sets an ILC1 option board clock error.

Replace the meter battery. Using Metercat support software, reprogram the A3 ALPHA meter/collector. The ILC1 option board clock error will clear within 15 minutes. Once the ILC1 option board clock error clears, the ILC1 will resume LAN communications. Contact Elster Electricity if this error code continues to display on the LCD.

**Carryover error.** This code indicates that the ILC1 option board's battery-backed RAM was not maintained during a power failure. When there is a power failure, battery-backed RAM on the ILC1 option board is maintained by the A3 ALPHA meter's super capacitor or battery. If both of these fail, the data stored in RAM is lost. Upon a subsequent power restoration, the ILC1 option board will rebuild the current billing data for all REX meters in the network. All previous billing data will be lost.

Replace the meter battery. Using Metercat support software, reprogram the A3 ALPHA meter/collector. The ILC1 option board clock error will clear within 15 minutes. Once the ILC1 option board clock error clears, the ILC1 will resume LAN communications. Contact Elster Electricity if this error code continues to display on the LCD.

**Table CRC error.** This code indicates an error in the ILC1 option board's programming. Contact Elster Electricity if this error code is displayed on the LCD.

**General configuration error.** This code indicates a problem with the ILC1 option board's configuration or program. Contact Elster Electricity if this error code is displayed on the LCD.

**Shared memory error.** This code indicates a problem exists in the shared memory area. See "Memory Capacity" on page 10 for more information on shared memory. Contact Elster Electricity if this error code is displayed on the LCD.

**Power fail data save error.** This code indicates that the data saved in the ILC1 option board's nonvolatile memory during a power failure may be invalid. This error will be displayed when power is restored to the meter if a self check has discovered an error with the ILC1 option board's memory. Contact Elster Electricity if this error code continues to be displayed on the LCD.

### **ILC1 Option Board Status Codes**

ILC1 status code must be programmed as a displayable item to appear on the A3 ALPHA meter LCD using Metercat support software. The status code indicates the presence of an ILC1 option board and that it is performing the collector function. Unlike error codes, the status codes do not indicate a problem with the ILC1 option board. Table 2 identifies the status condition and its associated display quantity value. The quantity identifier is the same for all ILC1 option board status codes and can be programmed to be any numeric character (represented by **i** in Table 2).

Table 2. Status condition and code

<b>Condition</b>	<b>Quantity identifier</b>	<b>Display quantity value</b>
Collector operation	iii	000001

**Collector operation.** This code indicates that the A3 ALPHA meter is operating as a collector. While operating as a collector, the A3 ALPHA meter is collecting and storing REX meter data using the ILC1 option board.

## ILC1 Option Board Information

ILC1 option board information can be displayed on the A3 ALPHA meter LCD. Table 3 identifies all the items that are available for display. The quantity identifier must be a numeric character (represented by **i** in Table 3) and should be unique for each item that you want to display. Use Metercat meter support software to select the display items and their associated quantity identifier.

Table 3. Information item and display format

Display item	Quantity identifier	Display quantity value
REX LAN ID 1	iii	xxxx
REX LAN ID 2	iii	xxxxxx
REX utility ID	iii	xxxxxx
ILC number of nodes	iii	xxxxxx
ILC number of repeaters	iii	xxxxxx

**REX LAN ID 1.** This item displays the first 4 digits of the ILC1 option board LAN ID.

**REX LAN ID 2.** This item displays the last 6 digits of the ILC1 option board LAN ID.

**REX utility ID.** This item displays the utility ID for the A3 ALPHA meter/collector. The utility ID is the same for all meters that are part of the same network.

**ILC number of nodes.** This item displays the number of REX meters that are registered to the collector.

**ILC number of repeaters.** This item displays the number of REX meters that are registered to the collector and that are operating as a repeater.

## Memory Capacity

The ILC1 option board will support a maximum of 1024 registered nodes. The amount of memory required to store current billing data, previous period billing data, previous season data, and configuration change data limits the amount of data available for storage of load profile data. There are two variables that control the amount of shared memory required to store load profile data:

- The number of REX meters for which load profile data is to be stored.
- The number of days of data to store for each REX meter.

As these two load profile variables are increased, the maximum number of registered nodes must be decreased to allow all of the data to fit within the available shared memory on the ILC1 option board.

Table 4 shows the estimated maximum number of days of load profiling data that can be stored for various configurations. Table 4 assumes the A3 ALPHA meter/collector does the following:

- reads load profiling data from each registered REX meter based on the following schedule:
  - for 15-minute intervals, the collection time is every 4 hours
  - for 30-minute intervals, the collection time is every 6 hours
  - for 60-minute intervals, the collection time is every 12 hours
- reads and stores load profiling data for all registered nodes

The ILC1 option board memory configuration is set at the factory and cannot be changed.

Table 4. Max. number of days of storage available per interval

<b>REX meters allowed to register</b>	<b>Days of LP storage</b>
<b>Load profiling interval: 15 minutes</b>	<b>Collection time: every 4 hours</b>
35	54
70	27
100	18
250	7
500	3
1024	1
<b>Load profiling interval: 30 minutes</b>	<b>Collection time: every 6 hours</b>
70	50
100	35
250	13
500	5
1024	1
<b>Load profiling interval: 60 minutes</b>	<b>Collection time: every 12 hours</b>
70	101
140	49
250	26
500	11
1024	3

**FCC and Industry  
Canada Compliance**

**Compliance Statement (Part 15.19)**

The A3 ALPHA meter/collector complies with Part 15 of the FCC Rules and with RSS-210 of Industry Canada. Operation is subject to the following two conditions:

1. This device may not cause harmful interference, and
2. This device must accept any interference received, including interference that may cause undesired operation.

**Warning (Part 15.21)**

Changes or modifications not expressly approved by Elster Electricity, LLC could void the user’s authority to operate the equipment.

**RF Radiation Safety Guidelines per Part 2 of FCC Rules and Regulations**

The meter should be installed in a location where there will be a separation greater than 20 cm (8 inches) from locations occupied by humans.

**User Information (Part 15.105)**

The A3 ALPHA meter/collector has been tested and found to comply with the limits for a Class B digital device, pursuant to part 15 of the FCC Rules. These

limits are designed to provide reasonable protection against harmful interference in a residential installation. This equipment generates, uses and can radiate radio frequency energy and, if not installed and used in accordance with the instructions, may cause harmful interference to radio communications. However, there is no guarantee that interference will not occur in a particular installation. If this equipment does cause harmful interference to radio or television reception, the user is encouraged to try to correct the interference by one or more of the following measures:

- Reorient or relocate the receiving antenna.
- Move the receiving equipment farther away from the A3 ALPHA meter/collector.
- Consult the dealer or an experienced radio/TV technician for help.

### **Industry Canada Statement**

The term "IC" before the certification/registration number only signifies that the Industry Canada technical specifications were met.

### **Technical Specifications**

Appendix E, "Technical Specifications," of the A3 ALPHA Meter Technical Manual (TM42-2190) lists the meter specifications for an A3 ALPHA meter. When the A3 ALPHA meter is operating as a collector, the operating range for a Form 35S meter is different than the specifications listed in TM42-2190.

### **Operating Ranges**

<b>Voltage</b>	<b>Nameplate nominal range</b>	<b>Operating range</b>
Form 35S	120 V to 240 V	96 V to 288 V
All other forms	120 V to 480 V	96 V to 528 V

Chapter 1, "Internal Telephone Modem," of the Elster Electricity Modems product guide (PG42-1006B or later) lists the specifications for the ITM3 option board.







**Elster Electricity, LLC**

Raleigh, North Carolina USA

+ 1800 338 5251 (US Technical Support)

+ 1800 257 9754 (US Sales Support)

+ 1 919 212 4800 (US Main)

+ 1 905 634 4895 (Canada)

[support@us.elster.com](mailto:support@us.elster.com)

[www.elsterelectricity.com](http://www.elsterelectricity.com)