

ALPHA meter

Installation instructions IL42-4001S

General

This instructional leaflet contains general installation instructions for the following single phase and polyphase watt-hour meters:

- socket-connected meters: 1S, 2S, 3S, 4S, 5S, 6S, 8S, 9S, 10S, 12S, 13S, 16S, 26S, 29S, 35S, 36S, 45S, 56S
- bottom-connected meters: 5A, 6A, 10A, 13A, 16A, 35A, 36A, 45A

See the following technical manuals for more information about the ALPHA meter:

- ALPHA® Meter Technical Manual (TM42-2180A or later)
- ALPHA Meter Options Technical Manual (TM42-2181B or later)
- ALPHA Plus® Meter Technical Manual (TM42-2182C or later)
- A3 ALPHA Meter Technical Manual (TM42-2190A or later)

⚠ WARNING

All meters are calibrated and tested before shipment. For proper installation, accuracy, and maximum life of the meters, use the following installation procedures.

Use authorized utility procedures to install and service metering equipment. Dangerous voltages are present. Equipment damage, personal injury, or death can result if safety precautions are not followed.

Use circuit closing devices on any current transformer secondaries (3S, 4S, 5S, 5A, 6S, 6A, 8S, 9S, 10S, 10A, 26S, 29S, 35S, 35A, 36S, and 36A meters). Equipment damage, personal injury, or death can result if circuit closing devices are not used.

⚠ WARNING

Form 45S, Form 45A, and Form 56S meters present additional risks of electrical shock that may result in severe personal injury or death when the cover is removed from energized meters unless certain additional safety procedures and precautions are followed. Be sure to follow the safety procedures and precautions when servicing Form 45S, Form 45A, and Form 56S meters as stated in this manual (see "Forms 45S, 45A, and 56S safety precautions" on page 3) as well as your authorized utility procedures.

Socket-connected installation

Before you install the meter, check the following:

- Are the socket and meter current class ratings compatible with the meter?
- Is the wiring to the meter socket correct? See the wiring diagrams on the following pages.
- Is a lightning arrestor present? If so, remove the paint from the socket rim where it contacts the arrestor's ground strap. This will ensure proper grounding.
- Is the TEST button in the unlocked position? If the TEST button is in the locked position, the meter will enter TEST mode when you install it. For more information, see the technical manual for your meter.

After you install the meter, check the following:

- If load is applied, check that the pulse arrows on the LCD are blinking.

The LCD has 2 sets of pulse arrows, one located above the other. The upper set of arrows indicates watt-hours, and the lower set indicates alternate energy (kVARh or kVAh, if available). The arrows pointing to the left indicate energy received; arrows pointing to the right indicate energy delivered. For more information, see the technical manual for your meter.

Bottom-connected installation

Before you install a bottom-connected meter, check the following:

- Determine where the meter is to be installed. It should be on a flat wall at the point of electrical service entrance cables.
- Are the meter class and service connections compatible with the meter?

To install a bottom-connected meter, perform these steps:

- 1 Mount the bottom-connected meter or the bottom-connected S-to-A adapter.¹

⚠ WARNING

Use authorized utility procedures to install ground connection before wiring. Dangerous voltages are present. Equipment damage, personal injury, or death can result from wiring an ungrounded meter.

- 2 Wire the meter. See the wiring diagrams beginning on page 3. If the wire diagram is larger than the wire, use only approved adapters. External meter wiring should be consistent with the meter class rating.

- For 100 amp meters, use #2 wiring (or in accordance with standard utility operating practices)
- For 150 amp meters, use #1 AWG or 50 mm² wiring (or in accordance with standard utility operating practices)
- For transformer rated meters, use #9 wiring (or in accordance with standard utility operating practices)

¹ Not supplied by Elster Solutions.

After you install a bottom-connected meter, check the following:

- If load is applied, check that the pulse arrows on the LCD are blinking.

The LCD has 2 sets of pulse arrows, one located above the other. The upper set of arrows indicates watthours, and the lower set indicates alternate energy (kVARh or kVAh, if available). The arrows pointing to the left indicate energy received; arrows pointing to the right indicate energy delivered. For more information, see the technical manual for your meter.

- The TEST annunciator is not blinking. If it is blinking, then remove the meter from service, remove the cover, and rotate the TEST button so that the meter is placed out of test mode. For more information, see the technical manual for your meter.

Forms 45S, 45A, and 56S safety precautions

⚠ WARNING

Form 45S, Form 45A, and Form 56S meters present additional risks of electrical shock that may result in severe personal injury or death when the cover is removed from energized meters unless certain additional safety procedures and precautions are followed. Be sure to follow the safety procedures and precautions when servicing Form 45S, Form 45A, and Form 56S meters as stated in this manual as well as your authorized procedures.

When using Forms 45S, 45A, and 56S meters, be sure to understand and follow the important safety-related concerns.

- Form 45S meters: safety concerns exist with Form 45S meters in any application in which socket jaw 7 is not grounded.
- Form 45A meters: safety concerns exist with Form 45A meters in any application in which the equivalent terminal to the Form 45S socket jaw 7 is not grounded (A-base voltage terminal #6, as numbered from left-to-right).
- Form 56S meters: safety concerns exist with Form 56S meters in any application in which socket jaw 16 is not grounded.

These safety concerns include, but are not necessarily limited to, the following:

- 3-wire delta applications
- dual single phase "star" configurations (may also be referred to as 5-wire, 2-phase)
- 4-wire delta applications in which the high leg is not tied to phase C

The primary safety concerns in these applications are as follows:

- 1 The meter battery terminals and circuit board electronics will be at line potential.
- 2 The circuit board electronics of any installed option board will be at line potential.
- 3 Any internal antenna or other electrical extension of any installed option board will be at line potential.

It is important to assess the potential hazards after removing the meter cover and disconnect the electrical power as necessary to perform service.

Installation wiring

All available ALPHA meter forms are listed and separated with respect to the type of service being metered. Use of Form 9S, 10S, and 10A (in 8S and 8A applications), and Form 16S (in Form 15S application) are also shown. Form 14S and 14A applications are simply 4 wire WYE services and would be metered by Form 16S and 16A. The more complicated wirings are shown using both PTs and CTs. The socket ground is shown for safety considerations. The neutral-to-ground connection is shown for example only. Actual neutral-to-ground connection should be performed within the operating utility's standard practice.

Single phase meters

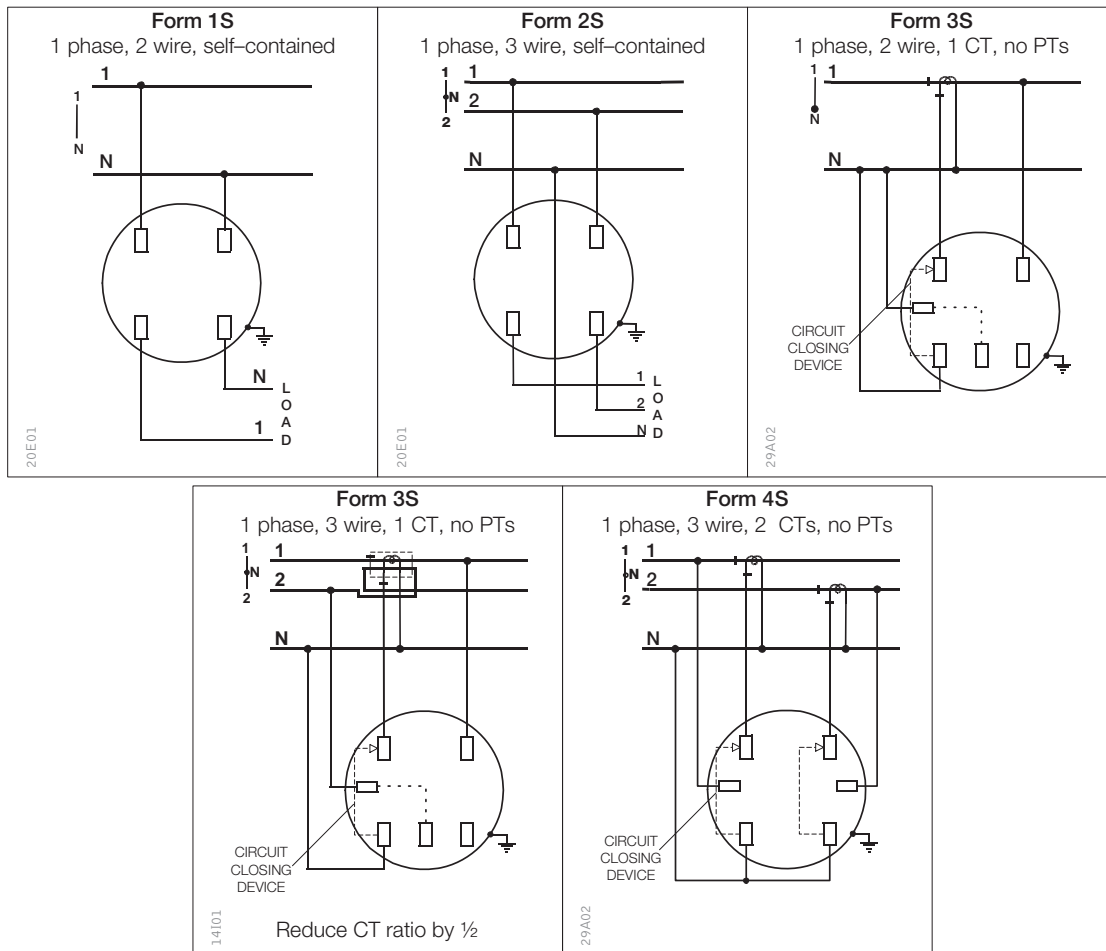

3 wire delta meters

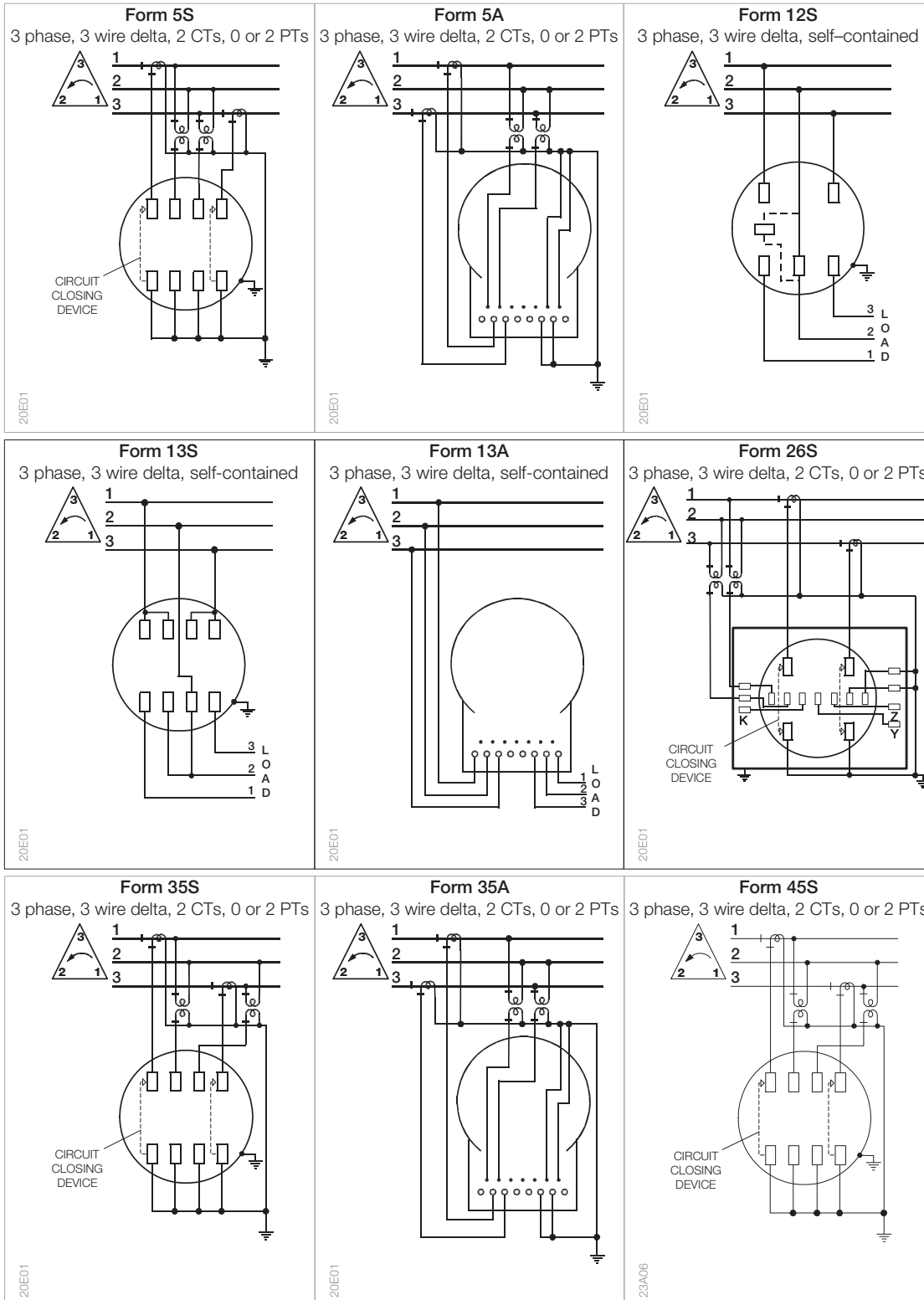

3 wire delta meters

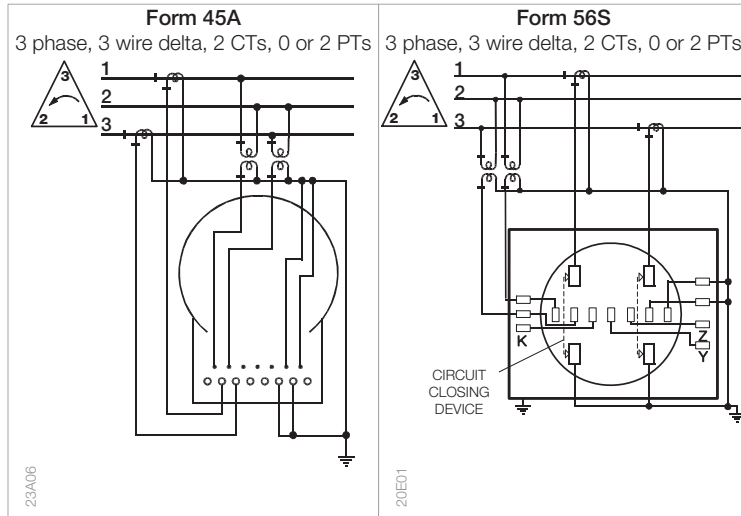

3 wire wye meters

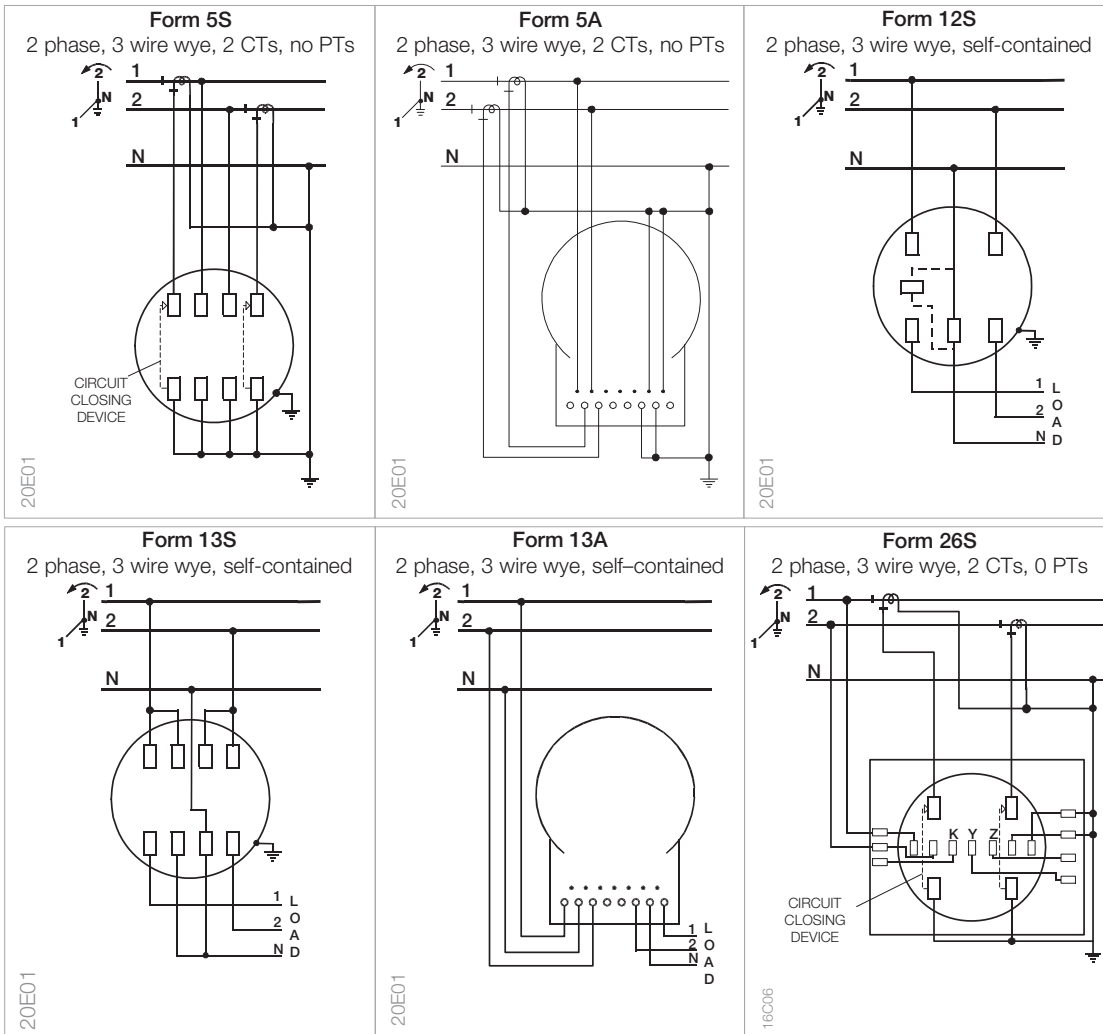

3 wire wye meters

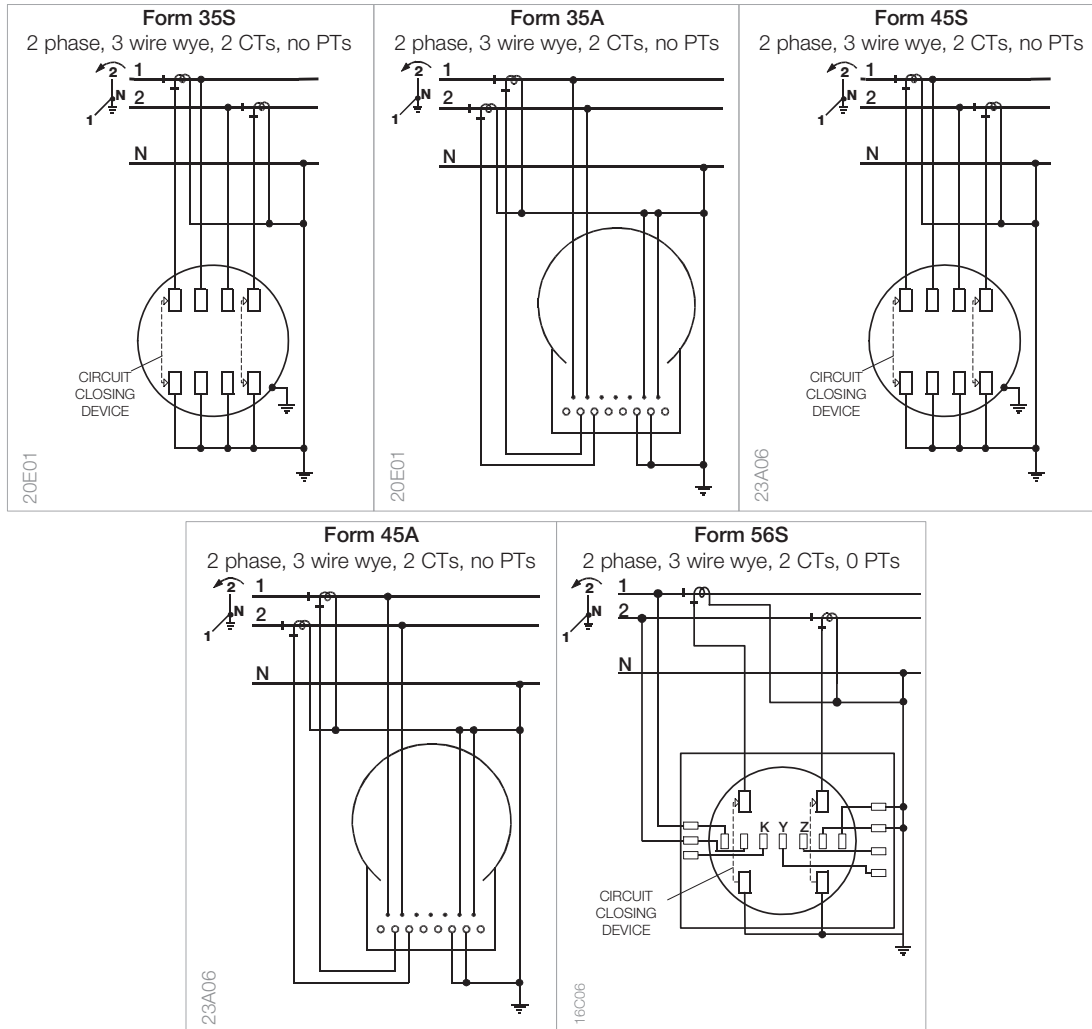

4 wire delta meters

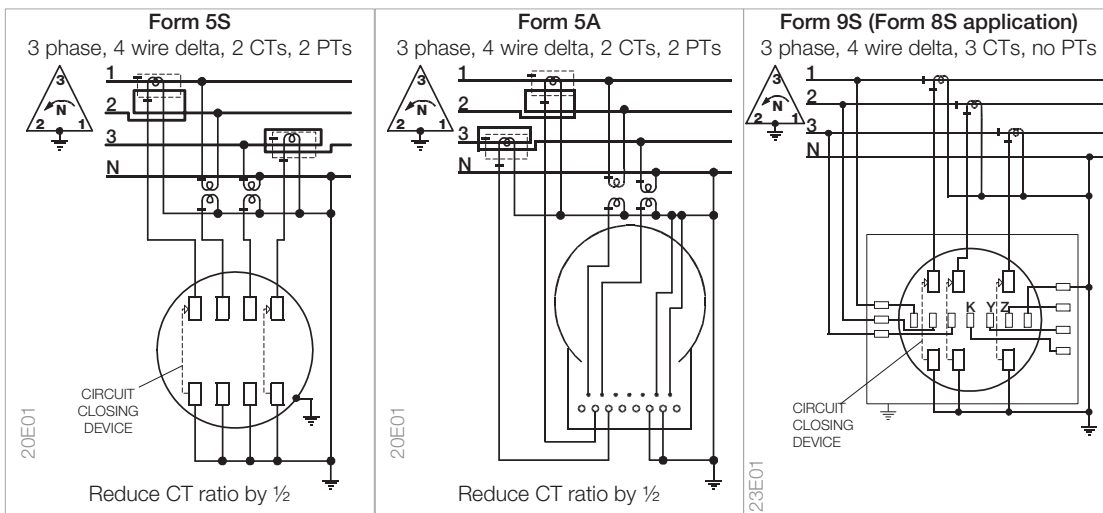

4 wire delta meters

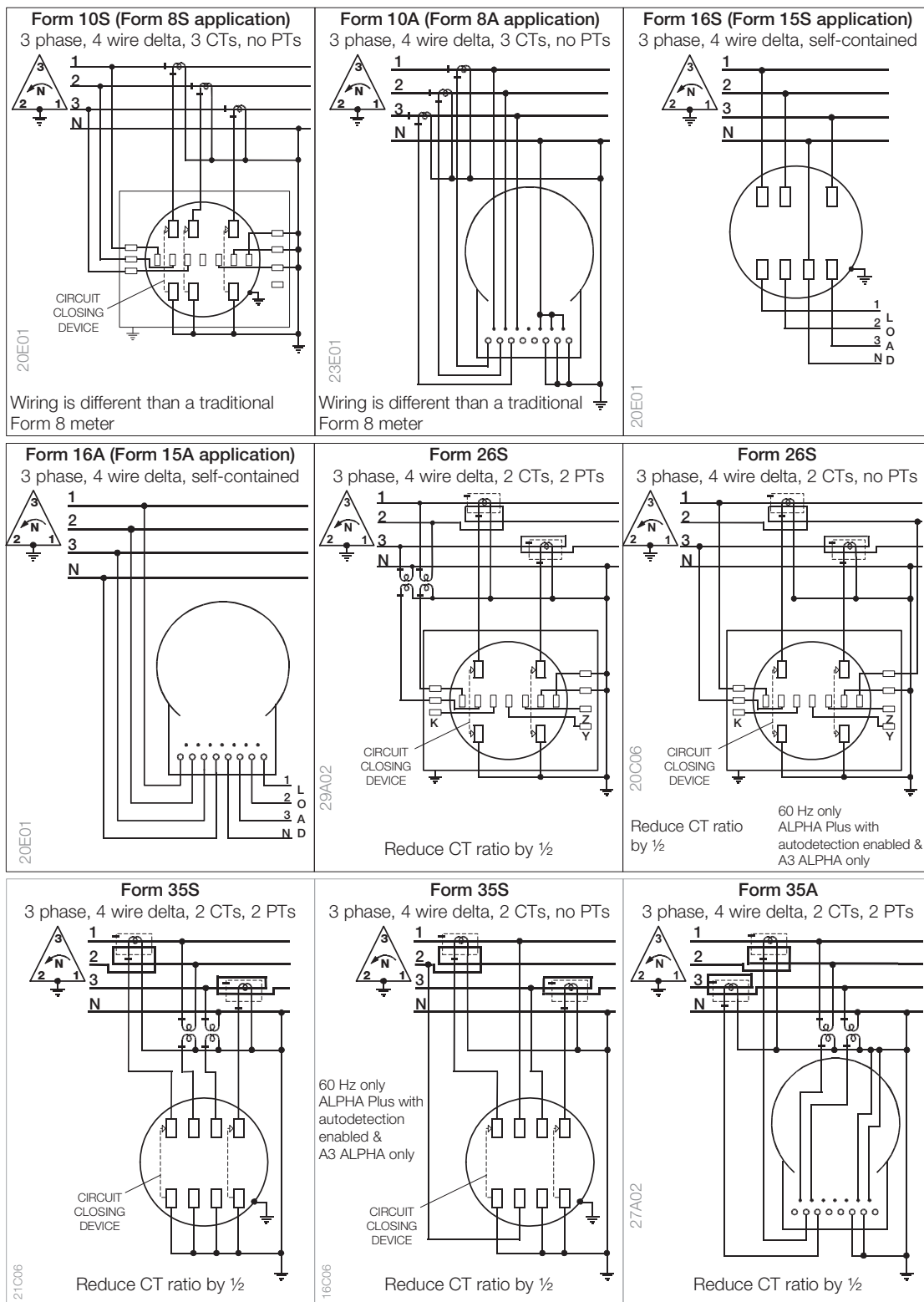

4 wire delta meters

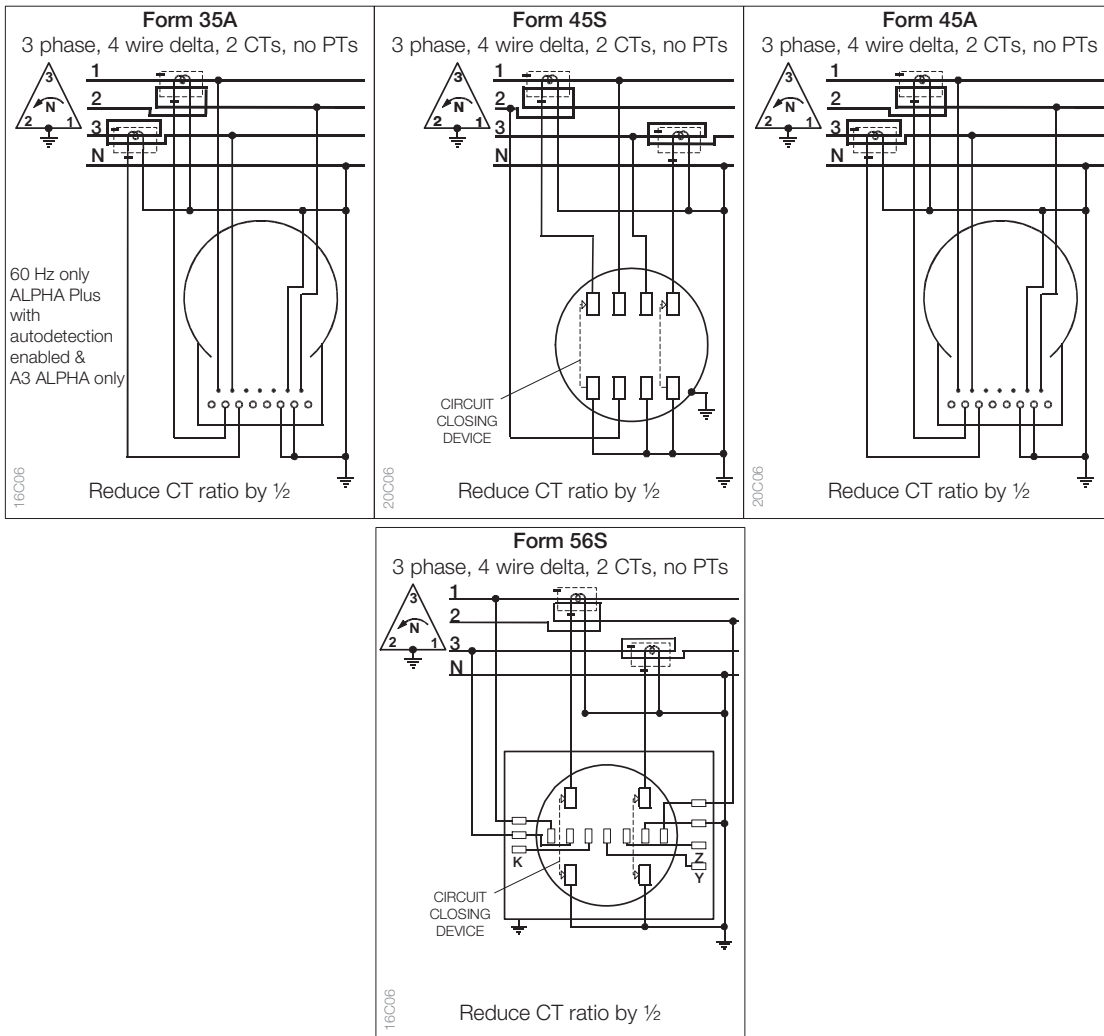

4 wire wye meters

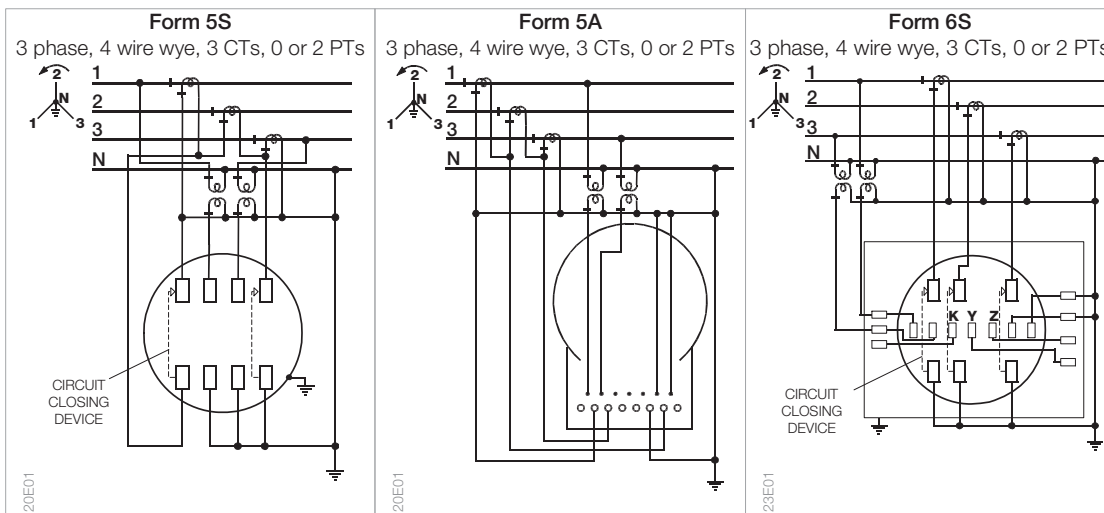

4 wire wye meters

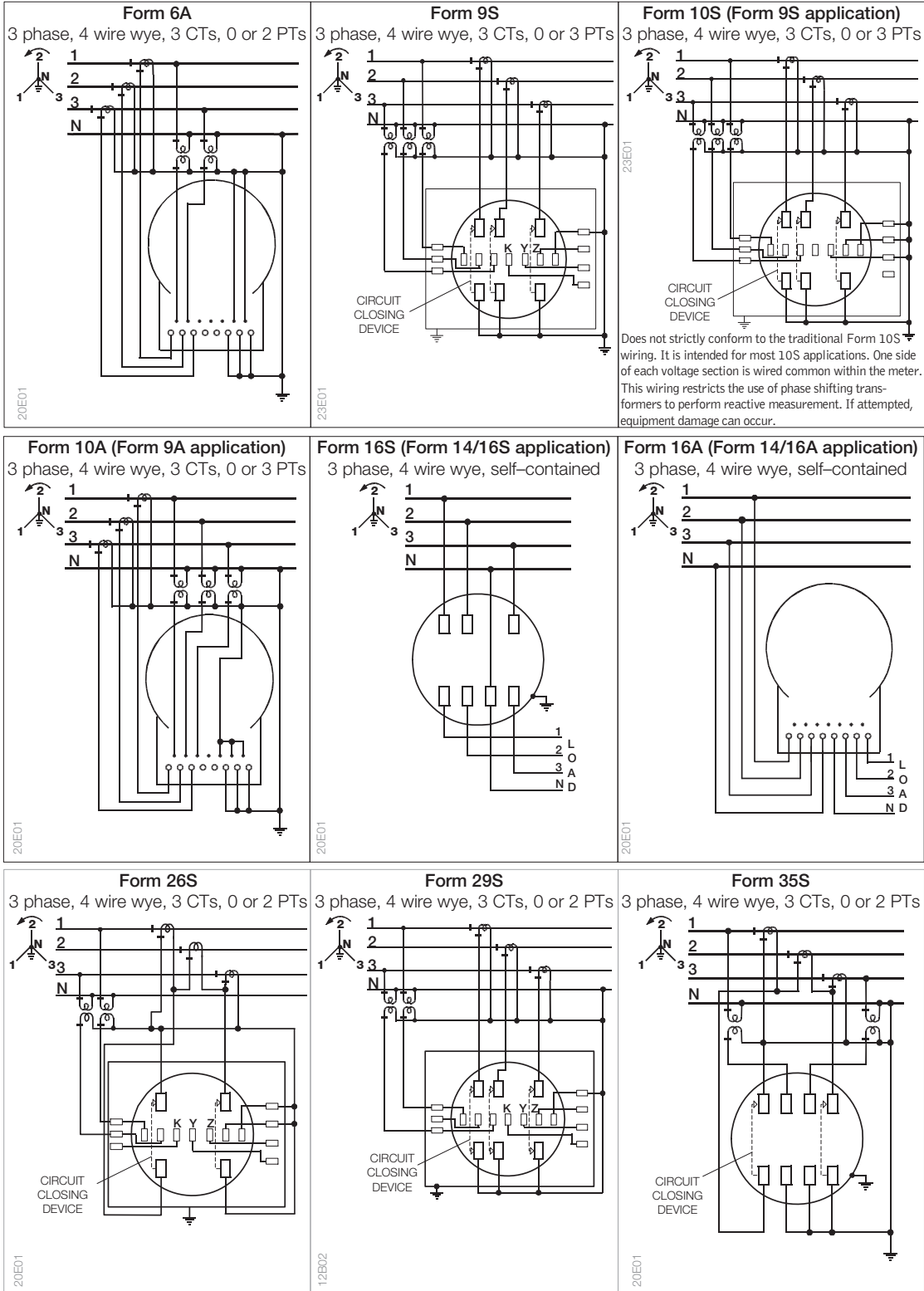

4 wire wye meters

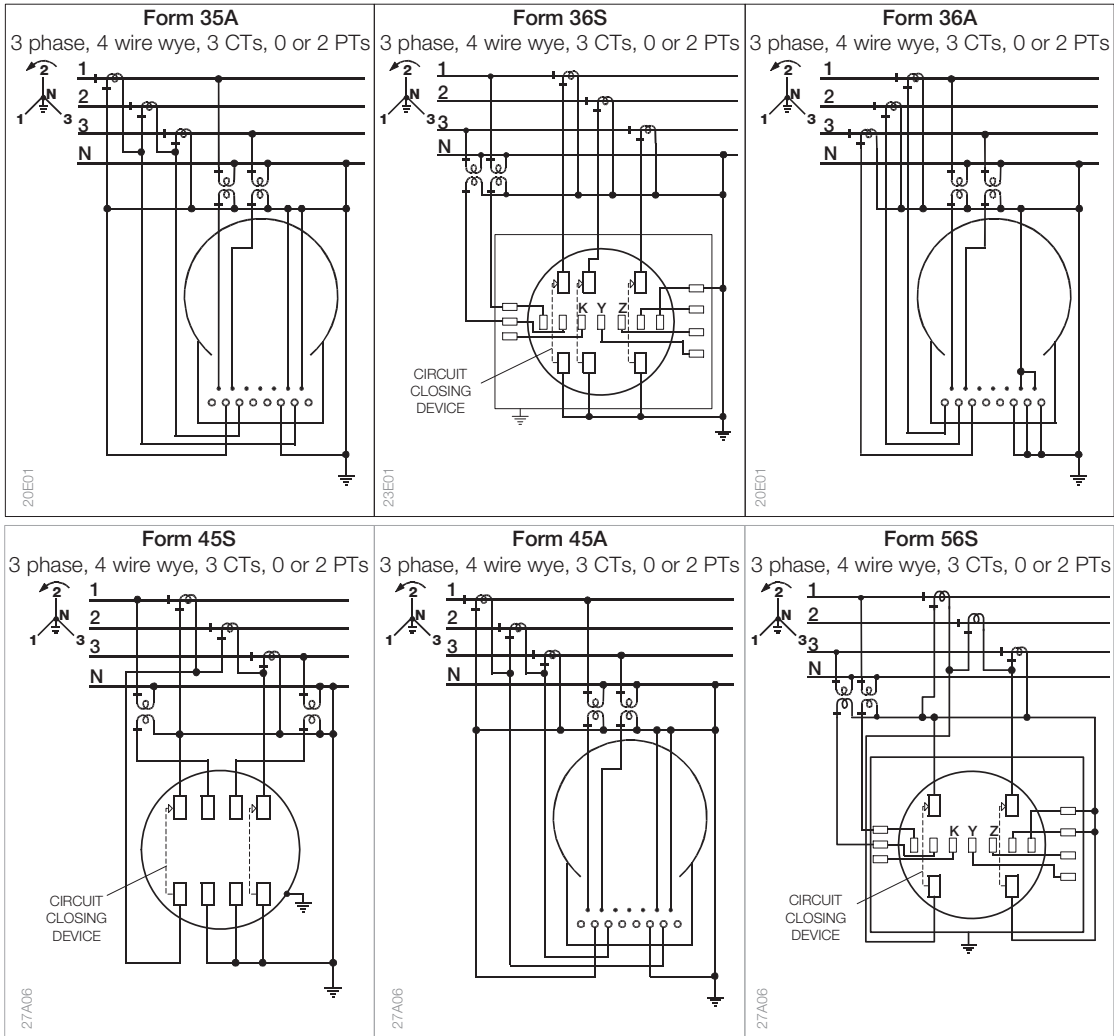

⚠ WARNING

Do not disassemble the meter chassis or the electronic module from the meter chassis with power present. Doing so could expose you to dangerous voltages, resulting in equipment damage, personal injury, or death.

Battery installation and replacement

Time-of-use meters are typically shipped with the battery installed and connected. If the battery is requested to be shipped disconnected, separately, or as a replacement, see the technical manual for procedures for battery installation or replacement.

NOTICE

It is important that the battery not be connected unless the meter has been powered for at least 1 minute from the AC line within the last hour. It is important that the meter is not energized while the battery is being installed or replaced (see the technical manual). After connecting the battery and re-energizing the meter, the display should be checked to verify proper operation (that is, scrolling from one display quantity to the next). Failure to follow the correct sequence for battery connection can result in early battery discharge, the register being inoperative, or both.

Relay output color coding

Multiple relay output configurations are available with high voltage, solid state relays. The relay outputs can be identified based on the number of output leads and their color coding. The following configurations are available:

- 1 relay with 6 output leads (see Figure 1)
- 2 relays with 6 output leads (see Figure 1)
- 4 relays with 8 output leads (see Figure 2)
- 4 relays with 9 output leads (see Figure 3)
- 6 relays with 12 output leads (see Figure 4)

In all cases, the output leads exit the meter using approximately 24 inches of cable. Regardless of the configuration present, the relays are assigned as follows:

- For ALPHA and ALPHA Plus meters:
 - KYZ1 is dedicated to kWh delivered.
 - KYZ2 is dedicated to kVAh delivered (for A1K or A1K+ meters) or kVARh delivered (for A1R or A1R+ meters)
 - When present, KYZ3 is dedicated to kWh received.
 - When present, KYZ4 is dedicated to kVAh received (for A1K or A1K+ meters) or kVARh received (for A1R or A1R+ meters)
- For A3 ALPHA meters:
 - All relays are fully programmable. Sources for the relays can be any basic metered quantity, EOI, load control, PQM test failure, or relay-related alarm condition. See the A3 ALPHA Meter Technical Manual (TM422190B or later) and the Metercat User Guide (TM42-2204B or later) for specific information.

Figure 1. Color coding for 1 or 2 relays with 6 output leads

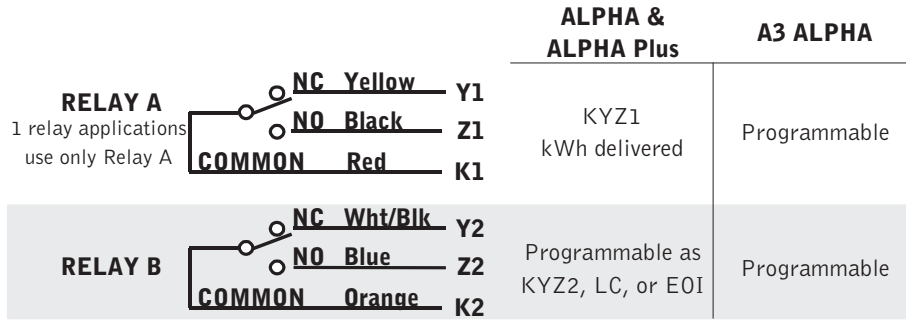

Figure 2. Color coding for 4 relays with 8 output leads

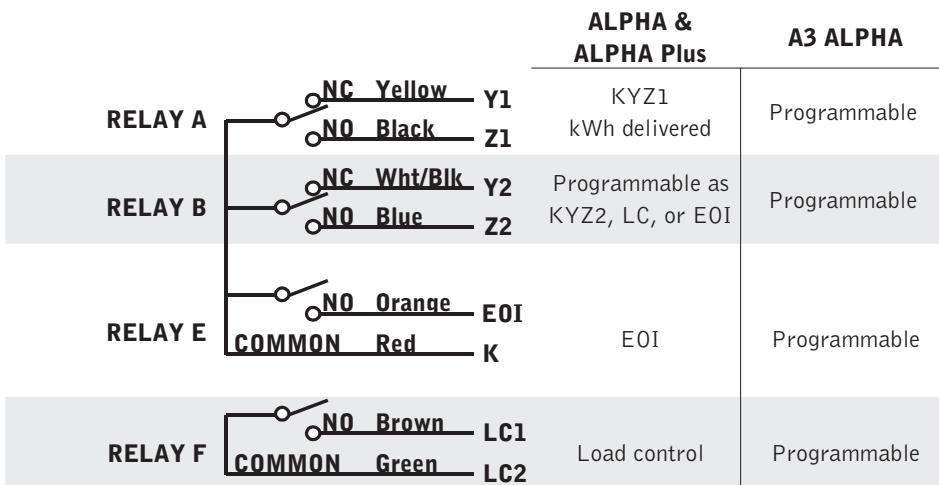

Figure 3. Color coding for 4 relays with 9 output leads

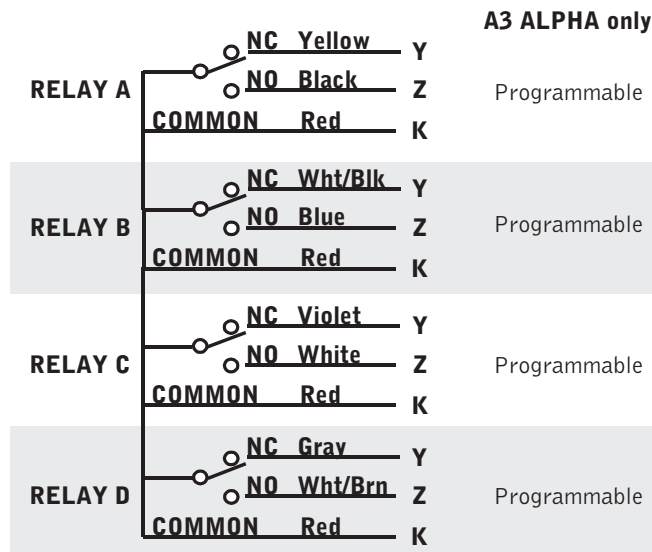

Figure 4. Color coding for 6 relays with 12 output leads

		ALPHA & ALPHA Plus	A3 ALPHA
RELAY A	NC Yellow Y1	KYZ1 kWh delivered	Programmable
	NO Black Z1		
RELAY B	NC Wht/Blk Y2	Programmable as KYZ2, LC, or EOI	Programmable
	NO Blue Z2		
RELAY C	NC Violet Y3	KYZ3 kWh received	Programmable
	NO White Z3		
RELAY D	NC Gray Y4	KYZ4 kVARh/kVAh received	Programmable
	NO Wht/Brn Z4		
RELAY E	NO Orange EOI	EOI	Programmable
	COMMON Red K		
RELAY F	NO Brown LC1	Load control	Programmable
	COMMON Green LC2		

FCC compliance (Part 15.105)

Most meters are Class B devices. However, some meters in some applications, when equipped with certain option boards, are certified as Class A devices. Additional FCC compliance information can be found in the documentation shipped with each meter, option board, kit, or other meter component.

Class B devices

This equipment has been tested and found to comply with the limits for a Class B digital device, pursuant to Part 15 of the FCC Rules. These limits are designed to provide reasonable protection against harmful interference in a residential installation. This equipment generates, uses and can radiate radio frequency energy and, if not installed and used in accordance with the instructions, may cause harmful interference to radio communications. However, there is no guarantee that interference will not occur in a particular installation. If this equipment does cause harmful interference to radio or television reception, which can be determined by turning the equipment off and on, the user is encouraged to try to correct the interference by one or more of the following measures:

- reorient or relocate the receiving antenna
- increase the separation between the equipment and the receiver
- connect the equipment into an outlet on a circuit different from that to which the receiver is connected
- consult the dealer or an experienced radio/TV technician for help

Class A devices

This equipment has been tested and found to comply with the limits for a Class A digital device, pursuant to part 15 of the FCC Rules. These limits are designed to provide reasonable protection against harmful interference when the equipment is operated in a commercial environment. This equipment generates, uses, and can radiate radio frequency energy and, if not installed and used in accordance with the instruction manual, may cause harmful interference to radio communications. Operation of this equipment in a residential area is likely to cause harmful interference in which case the user will be required to correct the interference at his own expense.

Compliance Statement (Part 15.19)

This device complies with Part 15 of the FCC Rules. Operation is subject to the following two conditions: (1) This device may not cause harmful interference, and (2) this device must accept any interference received, including interference that may cause undesired operation of the device.

Warning (Part 15.21)

Changes or modifications not expressly approved by Elster could void the user's authority to operate the equipment.

Industry Canada compliance

This Class B digital apparatus complies with Canadian ICES-003. Cet appareil numérique de la classe B est conforme à la norme NMB-003 du Canada.

DISCLAIMER OF WARRANTIES REGARDING MODULE AND OPERATION OF COMBINED MODULE/METER

This meter may include a third-party communication module ("Module"), installed at the customer's request, that was NOT manufactured by Elster and is being installed AS IS. Therefore, without limiting the generality of the foregoing disclaimer, ELSTER DISCLAIMS ANY AND ALL WARRANTIES, EXPRESS OR IMPLIED, REGARDING THE MODULE AND OPERATION OF THE COMBINED MODULE/METER WITH THE ANSI OR FCC REQUIREMENTS. While Elster may act as a broker for the Module manufacturer's warranties, any express or implied warranty regarding the Module or operation of the combined Module/meter, to the extent that such warranty may exist, is provided SOLELY BY THE MODULE'S MANUFACTURER.

DISCLAIMER OF WARRANTIES AND LIMITATIONS OF LIABILITY

There are no understandings, agreements, representations, or warranties either express or implied, including warranties of merchantability or fitness for a particular purpose, other than those specifically set out by any existing contract between the parties. Any such contract states the entire obligation of the seller. The contents of this document shall not become part of or modify any prior existing agreement, commitment, or relationship.

The information, recommendations, descriptions, and safety notices in this document are based on Elster Solutions, LLC experience and judgment with respect to operation and maintenance of the described product. This information should not be considered as all-inclusive or covering all contingencies. If further information is required, Elster Solutions, LLC should be consulted.

No warranties, either expressed or implied, including warranties of fitness for a particular purpose or merchantability, or warranties arising from the course of dealing or usage of trade, are made regarding the information, recommendations, descriptions, warnings, and cautions contained herein.

In no event will Elster Solutions, LLC be responsible to the user in contract, in tort (including negligence), strict liability or otherwise for any special, indirect, incidental, or consequential damage or loss whatsoever, including but not limited to: damage or loss of use of equipment, cost of capital, loss of profits or revenues, or claims against the user by its customers resulting from the use of the information, recommendations, descriptions, and safety notices contained herein.