

UNCLASSIFIED

Installation Manual

PERSISTENT PERIMETER

DETECTION RADAR

ELM-2114



UNCLASSIFIED

TABLE OF CONTENTS

1. GENERAL3

2. KIT CONTENTS4

2.1. TRANSCIVER: 4

2.2. POE (CUSTOMER SUPPLY) 4

2.3. INSTALLATION REMOVABLE MEDIA 5

3. SYSTEM MAPS INSTALLATION / SETUP.....6

3.1. MANUAL INSTALLATION 6

3.2. AUTOMATIC INSTALLATION..... 6

4. ELM-2114 OPERATING SYSTEM INSTALLATION.....7

4.1. ELM2114 – OPERATING SYSTEM INSTALLATION (HMI)..... 7

4.2. RADAR COM SET APPLICATION..... 11

5. RADAR CONFIGURATION SETUP15

5.1. SETTING THE RADAR LOCATION 15

6. MECHANICAL DESCRIPTION17

6.1. MECHANICAL SPECIFICATION 17

6.2. SIDE VIEW AND INSTALLATION DIRECTION 18

7. MECHANICAL INSTALLATION GUIDE LINES:19

7.1. INSTALLATION HEIGHT: 19

7.2. ROI OBSERVATION REQUIREMENT:..... 19

7.3. TWO RADARS INSTALLATION - DISTANCE CALCULATION 19

8. COMPONENTS INTERCONNECTION21

9. SAFETY INSTRUCTIONS22

9.1. ELECTRICAL SAFETY 23

9.2. RADHAZ SAFETY 23

10. POWER REQUIREMENTS.....24

11. RECOMMENDED 20[M] CABLE [CAN BE PURCHASE SEPARATELY].....25

This document contains proprietary information of ELTA System Ltd.

1. GENERAL

This Installation Manual describes installation procedures for the ELM-2114 Persistent Perimeter Detection Radar.

The ELM-2114 persistent perimeter detection radar is an advanced high-resolution radar with unique and outstanding capabilities. Featuring simultaneous multi beam technology, it provides persistent surveillance and instantaneous target tracking over the entire region of interest (ROI), allowing an immediate and simultaneous detection, monitoring and tracking of all moving ground targets in the ROI, in tough weather conditions.

The main feature of the ELM-2114 is extremely low false alarm rate, crucial for perimeter monitoring. It is equipped with a stationary (non-rotating) planar array covering (Staring at) an azimuth sector of 90°, with detection range capabilities of (up to) 500 m meters for a moving person, and up to 1000 m meters for moving vehicles, characterized by high reliability and maintenance-less hardware.

Unlike most Radars, this Radar does not have a scanning (mechanical or electronic) beam but rather covers all the area of interest simultaneously, using the Multibeam principle.

The Radar has the capability to be interface to a visual aid (day and/or night) (option) which can be steered automatically from the display station, allowing the operator to classify targets in the area of Interest.

2. KIT CONTENTS

The ELM-2114 Radar kit contains three (3) components:

2.1. Transceiver:

The transceiver module contains an RF front section and a digital circuit. The Transceiver includes a single POE plug.

The Transceiver unit is installed on a pole, mast or a tripod, using dedicated mechanical adapter that can be purchase separately.



Figure 1: Mechanical Adapter

2.2. POE (Customer Supply)

The Radar receives 48VDC power through a POE unit, which can be provided through dedicated POE unit, or customer standard network equipment, which already includes POE.



Figure 2: POE

This document contains proprietary information of ELTA System Ltd.

UNCLASSIFIED

2.3. Installation Removable Media

The enclosed installation Removable Media contains the radar operating application.

The ELM-2114 application supported by the following Operating Systems:

Win 7 / Win 10 pro.

DRAFT

This document contains proprietary information of ELTA System Ltd.

UNCLASSIFIED

3. SYSTEM MAPS INSTALLATION / SETUP

3.1. Manual installation

The System application displays raster and vector maps.

System Maps installation requires the following steps:

- Get raster maps, which are Orth-photo maps of the Geo TIFF format, uses WGS84 datum: (GeoTIFF format is georeference raster imagery, WGS84 datum is the World Geodetic System provided in 1984) in resolution of 1 to 5 meters per pixel.
- To obtain real measurements, verify that the Ortho-photograph is an aerial photograph geometrically corrected ("orthorectified"), such that the scale is unified and it has no distortion.
- The map coverage area should be 1Km x 1Km square for the region of interest, while the Radar placed at the corner of square and the surveillance area is within the square.
- Place the map file placed in the Maps directory on your operation station.

3.2. Automatic Installation

TBD

This document contains proprietary information of ELTA System Ltd.

UNCLASSIFIED

4. ELM-2114 OPERATING SYSTEM INSTALLATION

The following description specifies the ELM-2114 Operation System installation.

Insert the Operating System installation media and follow the on screen installation guide accordingly.

The installation includes two stages:

1. ELM2114 – Operating System Installation (HMI)
2. Radar Com Set Application - setting the radar network system communication

4.1. ELM2114 – Operating System Installation (HMI)

4.1.1. Welcome Screen

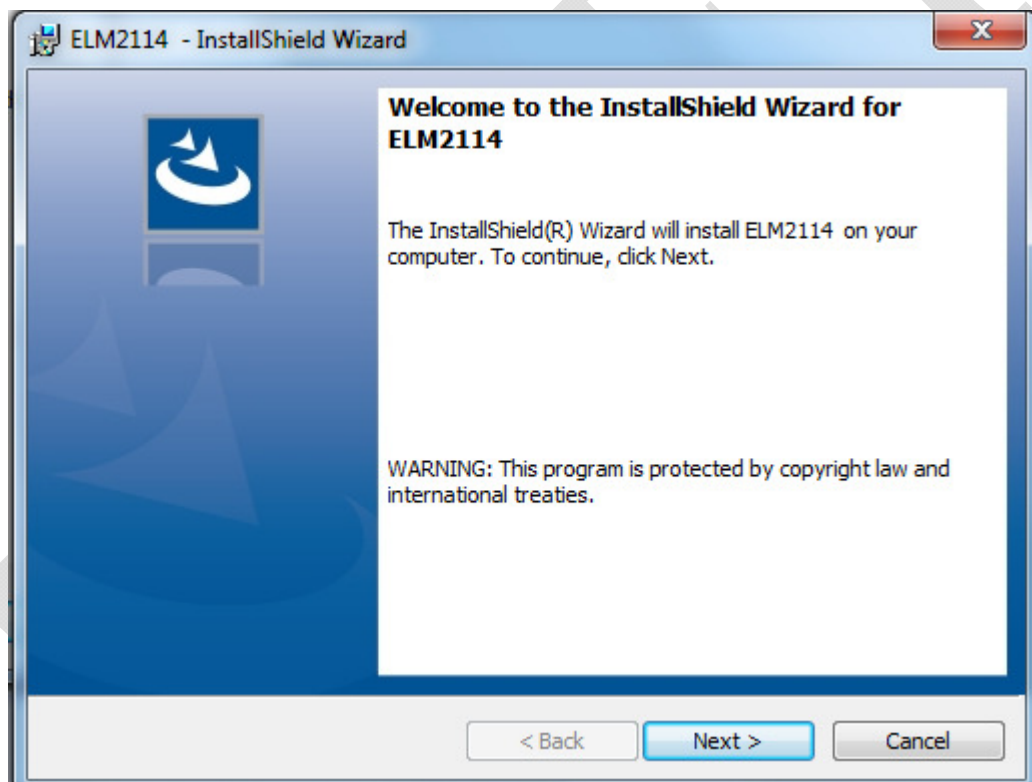

4.1.2. Installation Preparation screen

This document contains proprietary information of ELTA System Ltd.

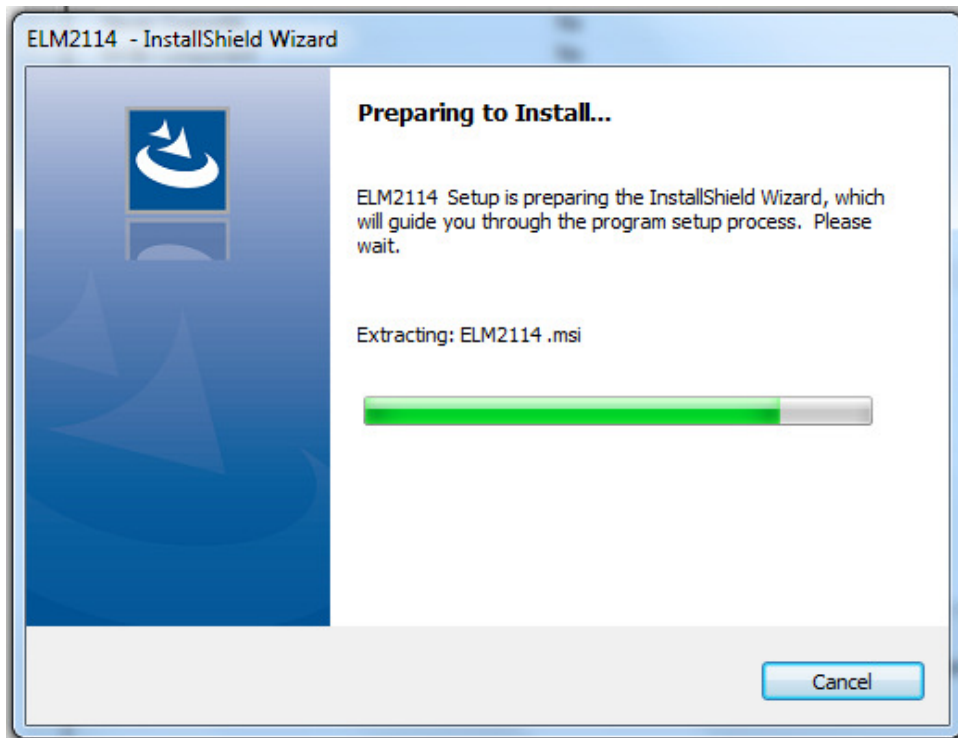

4.1.3. License Agreement

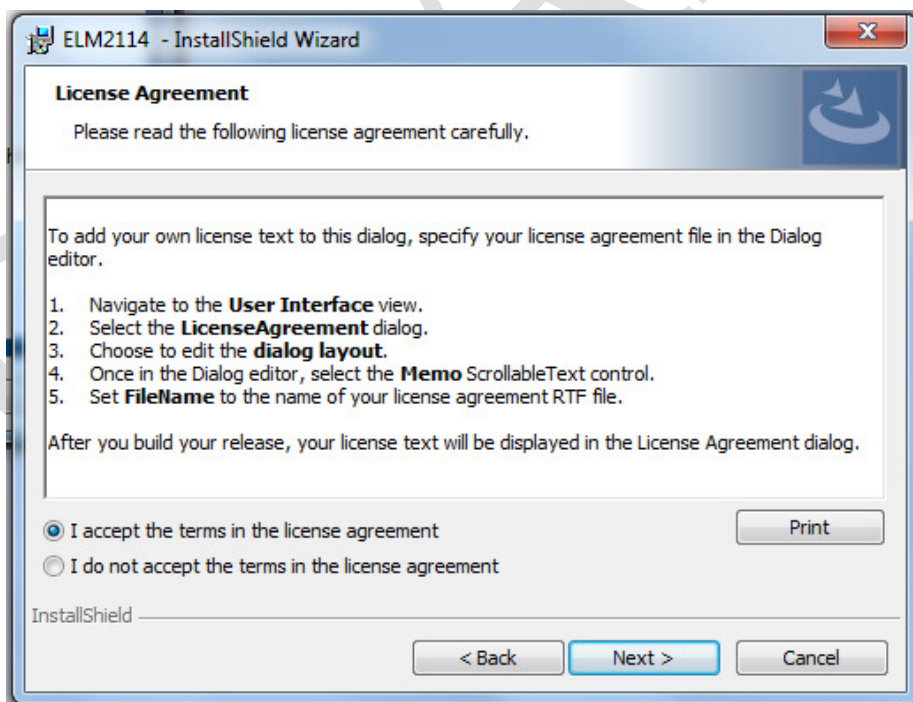

4.1.4. Operating System Installation Directory

This document contains proprietary information of ELTA System Ltd.

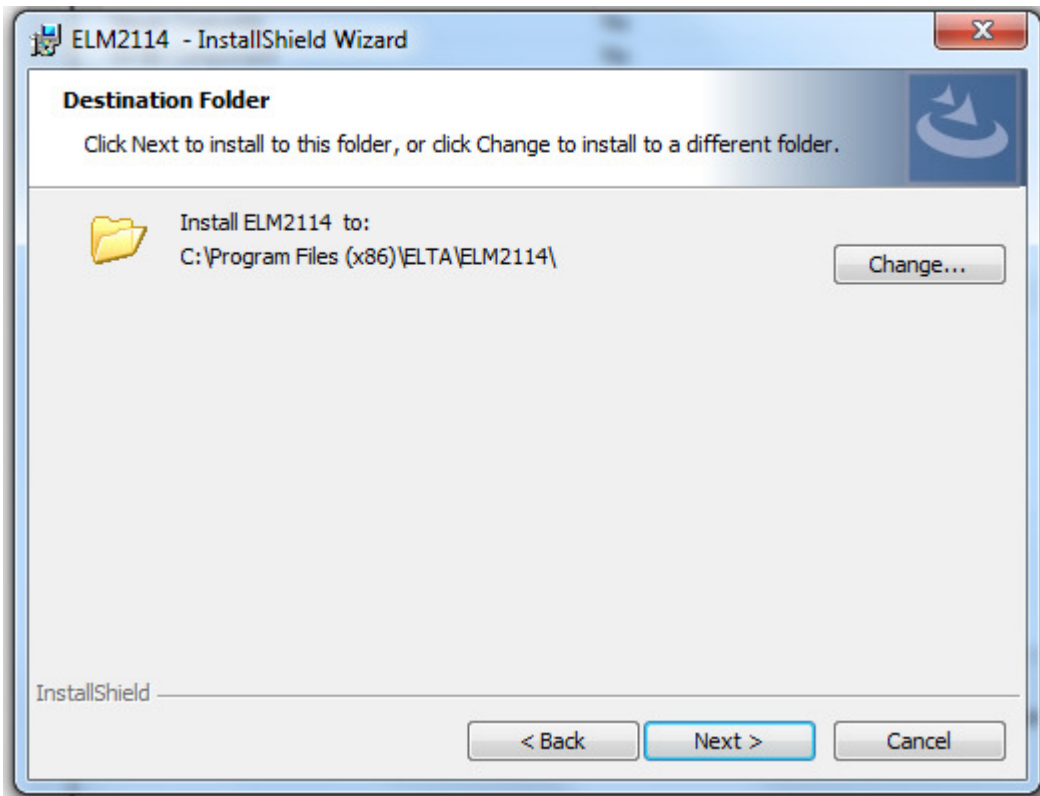

4.1.5. Installation Readiness Screen

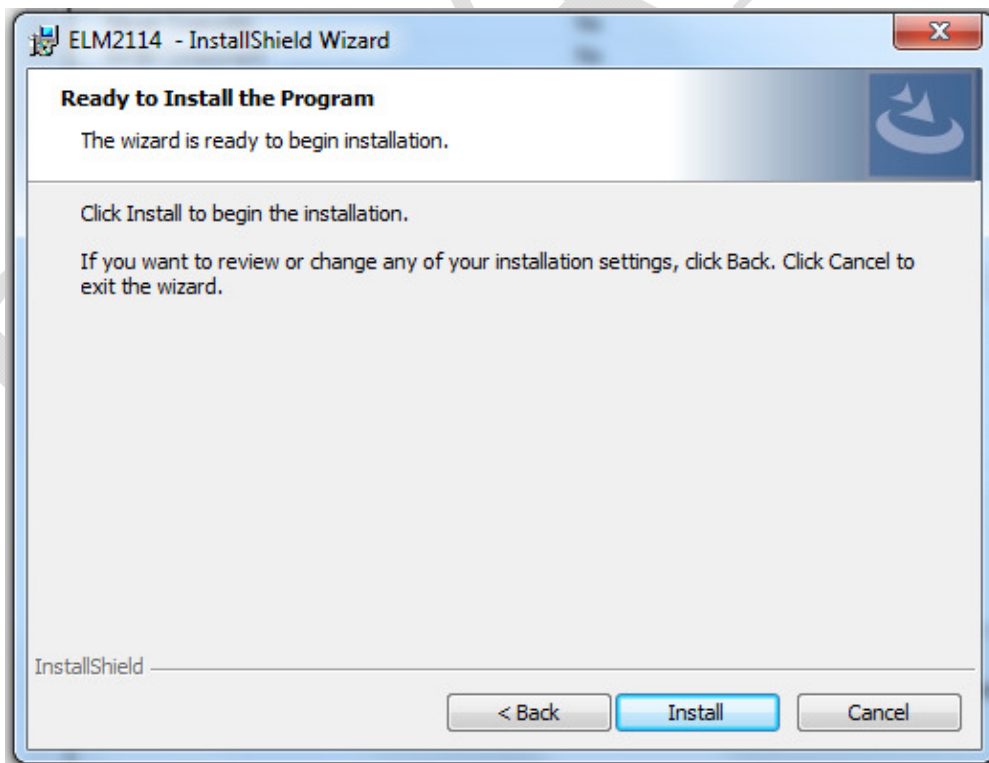

4.1.6. Installation Process Status

This document contains proprietary information of ELTA System Ltd.

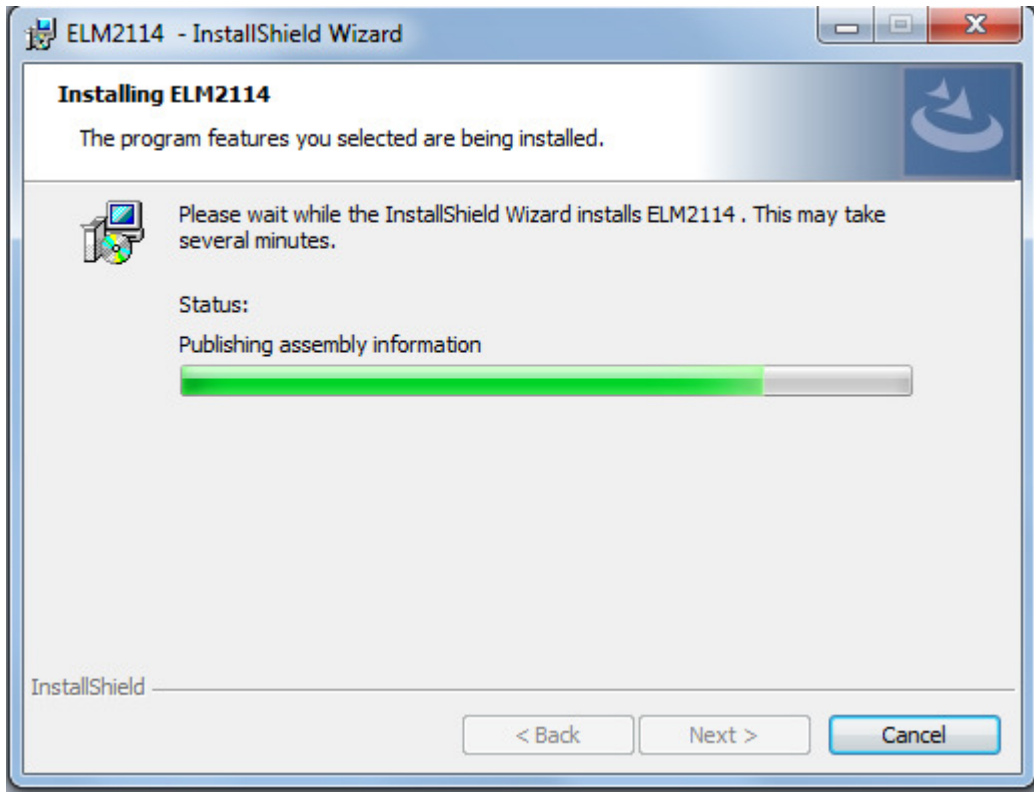

4.1.7. Installation Completion Screen

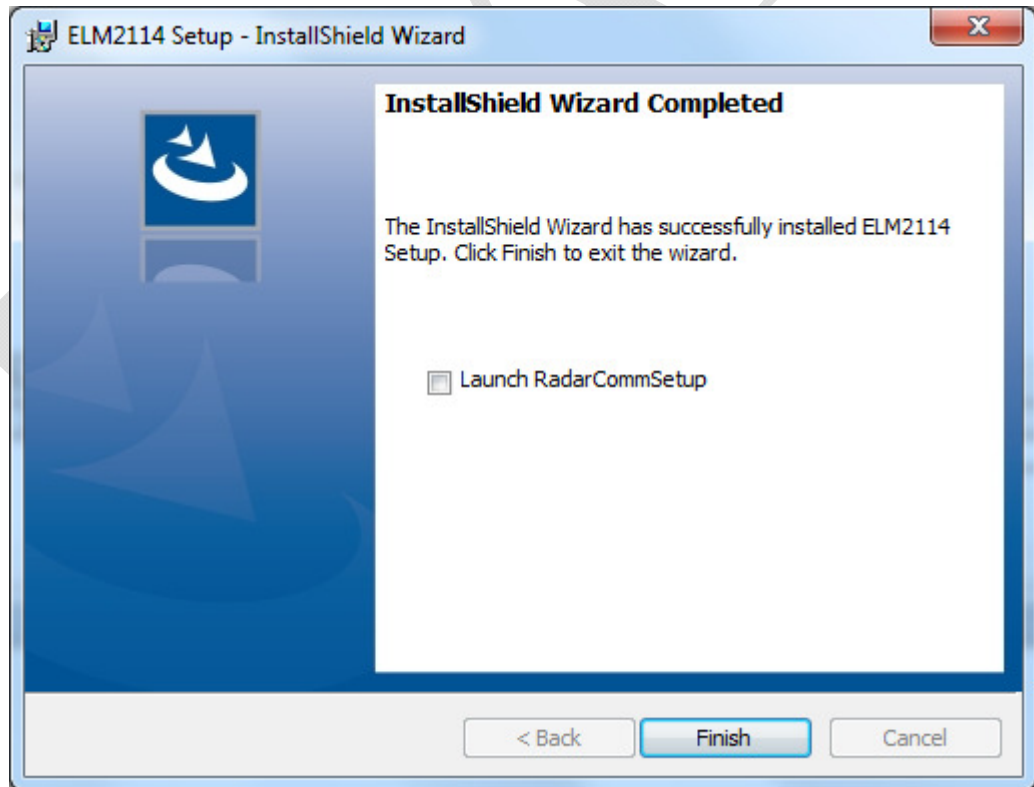

4.1.8. Uninstall

This document contains proprietary information of ELTA System Ltd.

UNCLASSIFIED

If the software has been installed before, the installation software provide the removal option of the previous version, before proceeding with the new one.

4.2. Radar Com Set Application

By the end of the operating system installation, put the checkmark to launch the radar burner application, and follow the on screen instructions, which will guide you how to set the required network connection between the radar and the operation PC.

4.2.1. Radar to PC connection setup screen

This is the radar connection setup... Please connect the radar. If the radar is already connected - Please disconnect and reconnect it's cable or cause power Off and On.

Next

Radar Connection		My PC Ethernet Adapter : Radar	
Radar IP Address:	<input type="text" value="..."/>	My PC IP Address:	<input type="text" value="125.105.19.101"/>
Radar Subnet Mask:	<input type="text" value="..."/>	My PC Subnet Mask:	<input type="text" value="255.255.0.0"/>
Radar Default Gateway:	<input type="text" value="..."/>	My PC Default Gateway:	<input type="text" value="125.105.0.0"/>
TCP Port:	<input type="text"/>		
UDP Port:	<input type="text"/>		
PC IP Address:	<input type="text" value="..."/>		

DSP Version: 0:0:0

This document contains proprietary information of ELTA System Ltd.

4.2.2. System Subnet Detection

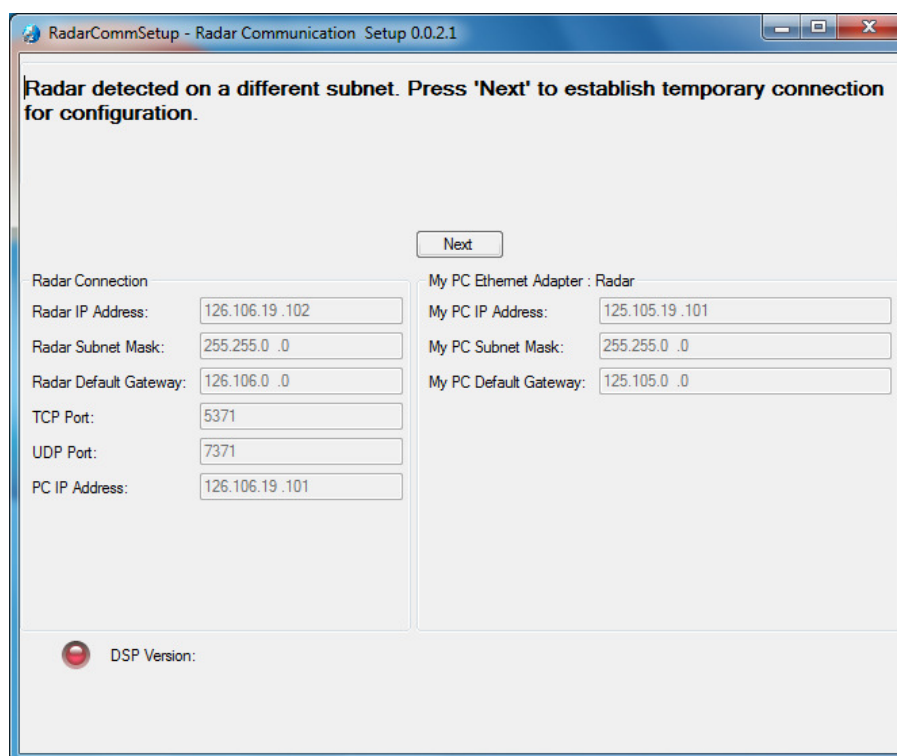

4.2.3. Temporary Connection Establishment

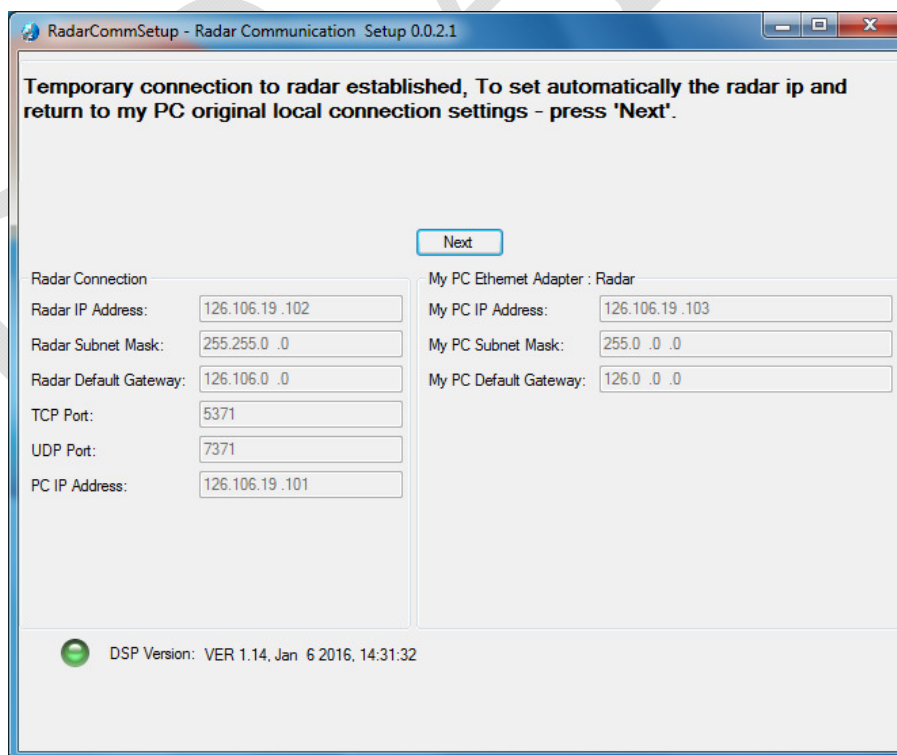

This document contains proprietary information of ELTA System Ltd.

4.2.4. Final Connection Screen

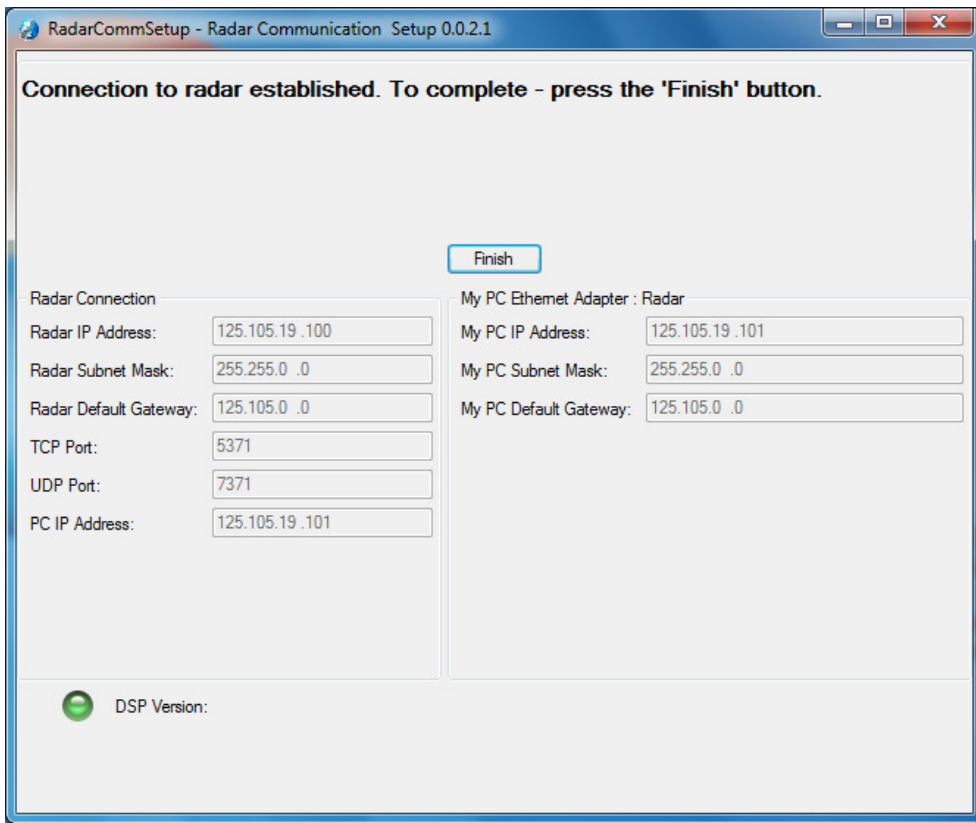

Note: In case the application automatically started following paragraph 5.2.4, it means that the Radar installed and configured correctly.

4.2.5. System Main Display



By the end of the process described above the following icons will appear on your desktop.

Double click on the RadarComSet ICON  will allow you to reconfigure the radar network set up in case that the system network was change and a new set up is required.



Double click on the  ICON shortcut will activate the radar operation system followed by the main system main display screen.

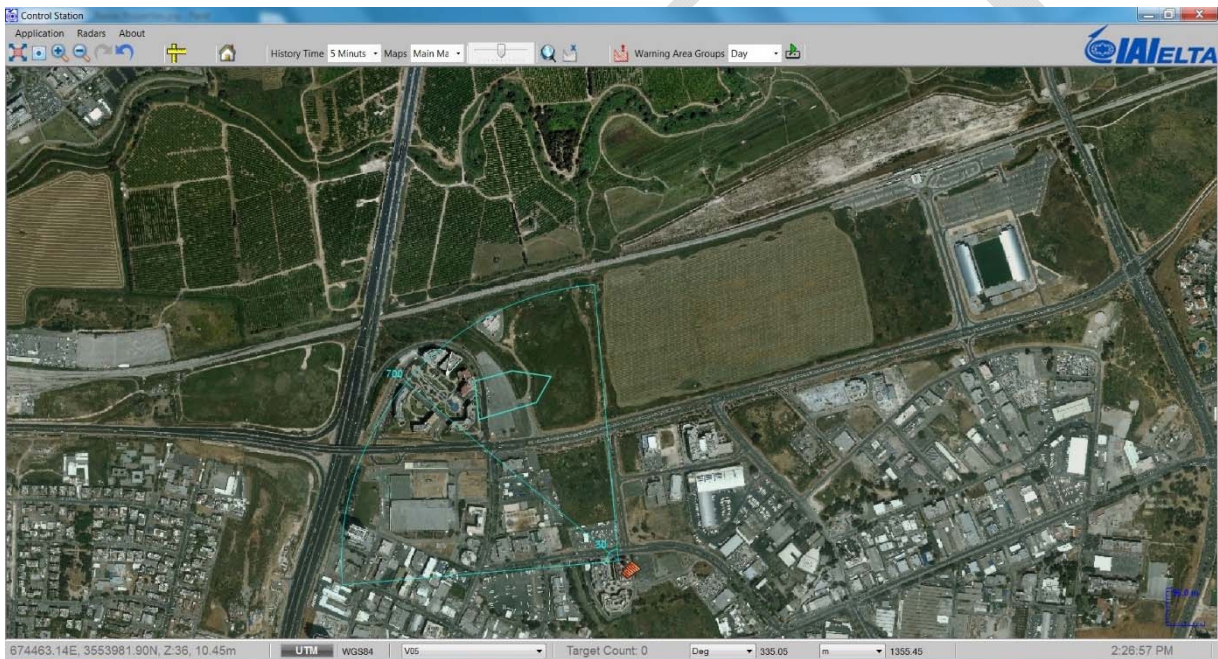

Figure 3: Main Display

This document contains proprietary information of ELTA System Ltd.

5. RADAR CONFIGURATION SETUP

5.1. Setting the Radar location

After successful system operation installation, run the application using the icon on the desktop and Open the **Radars menu** appears on the BAR menu and choose the **Radar Properties** option.

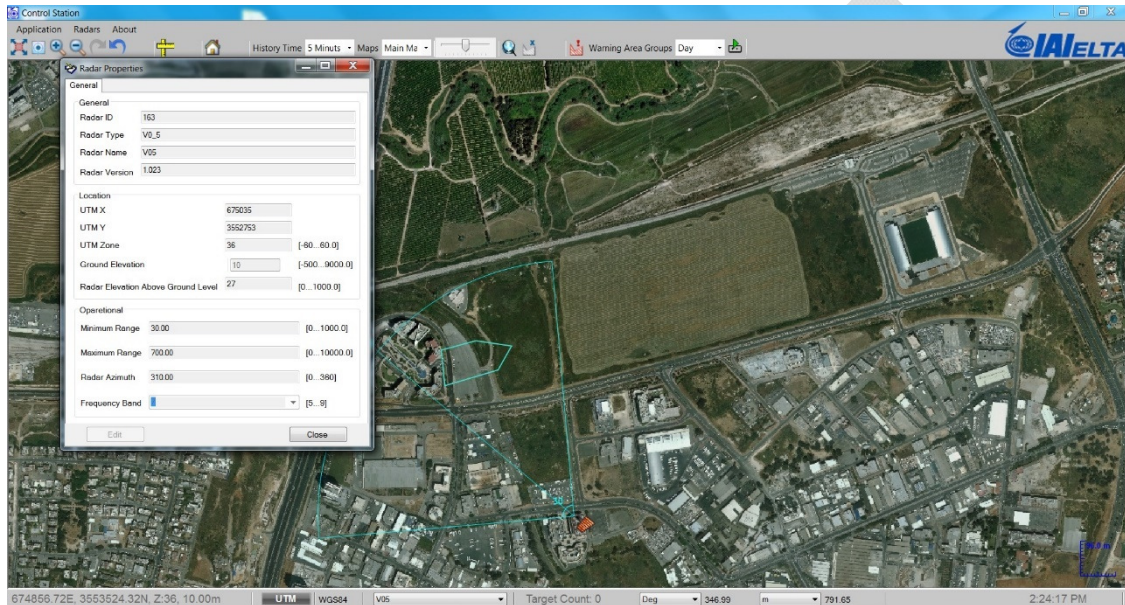

Figure 4: Radar Properties

5.1.1. General Field:

Leave the predefined default value with no change.

5.1.2. Location Field

Insert following data:

- UTM X – The radar [UTM] latitude position
- UTM Y – The radar [UTM] longitude position
- UTM Zone – The zone number of the area according to the UTM's zones map
- Ground Elevation - Radar height above sea level [M]
- Radar elevation above ground level [M]

5.1.3. Operational

This document contains proprietary information of ELTA System Ltd.

UNCLASSIFIED

Insert following data:

- Minimum Range
- Maximum Range
- Radar Azimuth – Radar azimuth relative to the north [degrees]
- Frequency Band – Default value that will need to be changed in case of using several radars to avoid interference between the radars.

Click on the Close Tab in order to save the setup data in the system.

5.1.4. North Alignment of the radar

After setting the radar to Tx On, find a significant known location reference target within the Radar ROI. Verify that the target known geo-position location is aligned with target's location presented on the display.

If there is a mismatching, check the radar's location and azimuth settings and perform the realignment

This document contains proprietary information of ELTA System Ltd.

6. MECHANICAL DESCRIPTION

The following Radar drawings describe the Radar mechanical dimensions that will allow the user to design the radar mounting mechanical adapter.

6.1. Mechanical Specification

Radar Weight – 1.0 Kg (approximately)

There are 4 threading holes (for 1/4 NC Allen bolts) at the radar bottom to attach the Radar to any mechanical adapter.

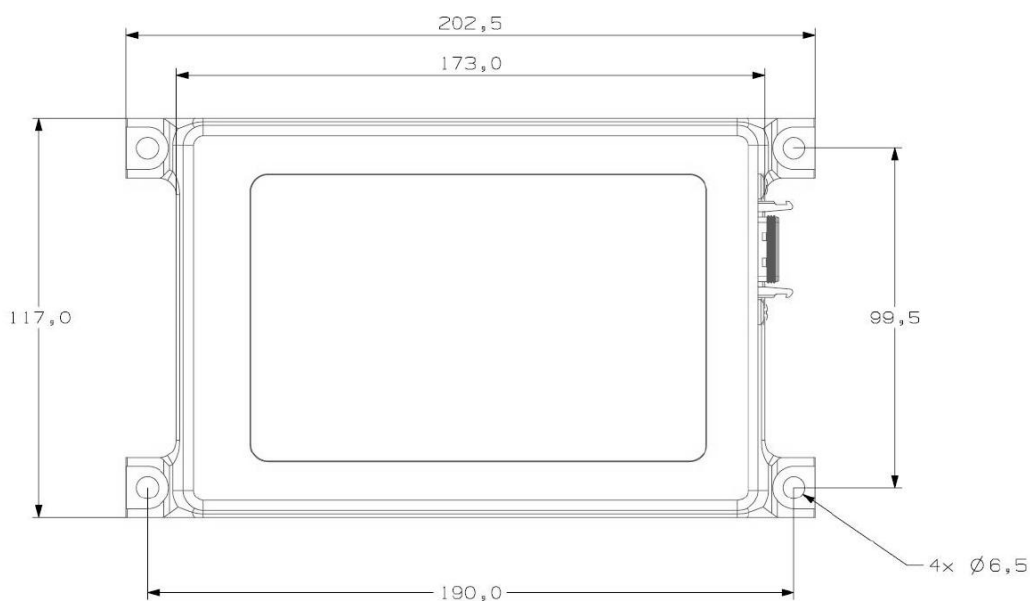
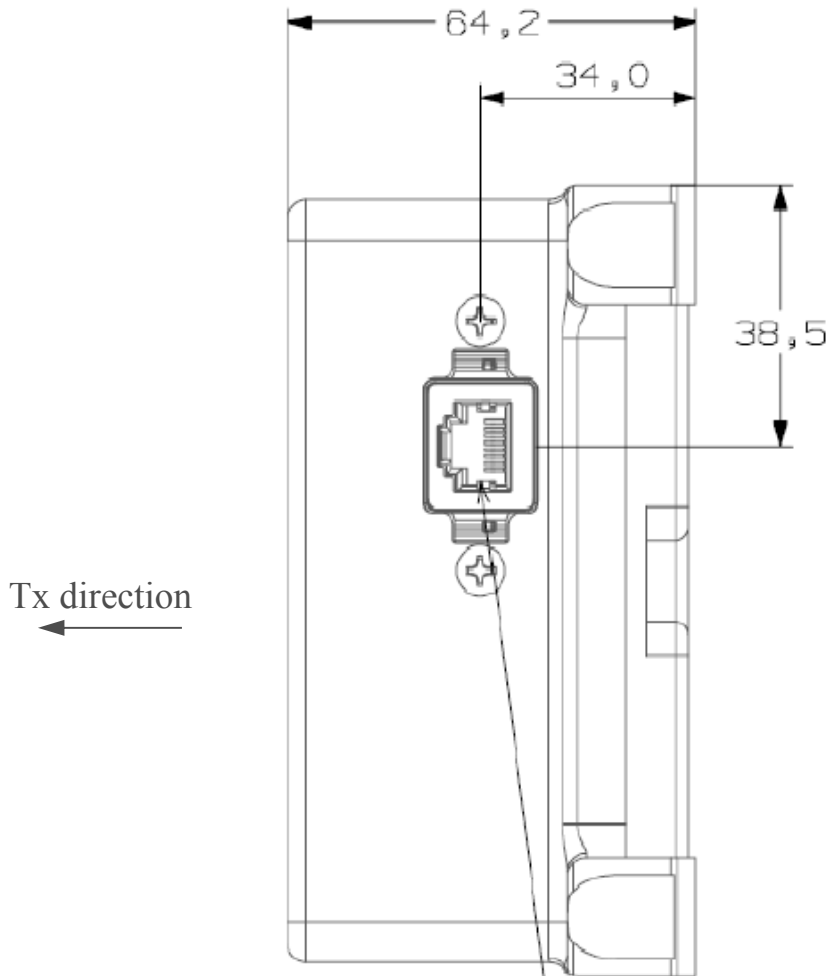

Figure 5: Mechanical Dimensions [mm]

6.2. Side view and installation direction



CONN. P/N RPBE-01-01-E

Figure6 : Radar Side View Dimensions

7. MECHANICAL INSTALLATION GUIDE LINES:

7.1. Installation height:

Between 1 to 1.5 meters and above the terrain to avoid multi pass at the radar coverage area.

7.2. ROI Observation Requirement:

- 180° azimuths with $\pm 7.5^\circ$ elevation sector in front of the Radar has to be free of objects obscuring the line of sight including cables and wires.
- The Radar elevation beam shape is a 15° wide "Pencil Beam" type. This beam has 0° squint relative to the mechanical radar elevation axis.

7.3. Two radars installation - Distance calculation

Installing two Radars for a 180° sector results in a minimal detection range in the overlapping region between the Radars. The minimal range in the overlapping region is dependent on the distance and angle between the Radars. The distance between the two installed Radars (for 180° coverage) is calculated as:

$$d = 2L \cdot \sin[6 + (45 - \alpha)]$$

where d is the distance between the two units, L is the minimum detection range (blind range) and α is the deviation from 90° between the Radars. α is $39^\circ < \alpha < 45^\circ$ in order to cover 180° in azimuth, and still get overlapping between the two units at the center of the covered area.

UNCLASSIFIED

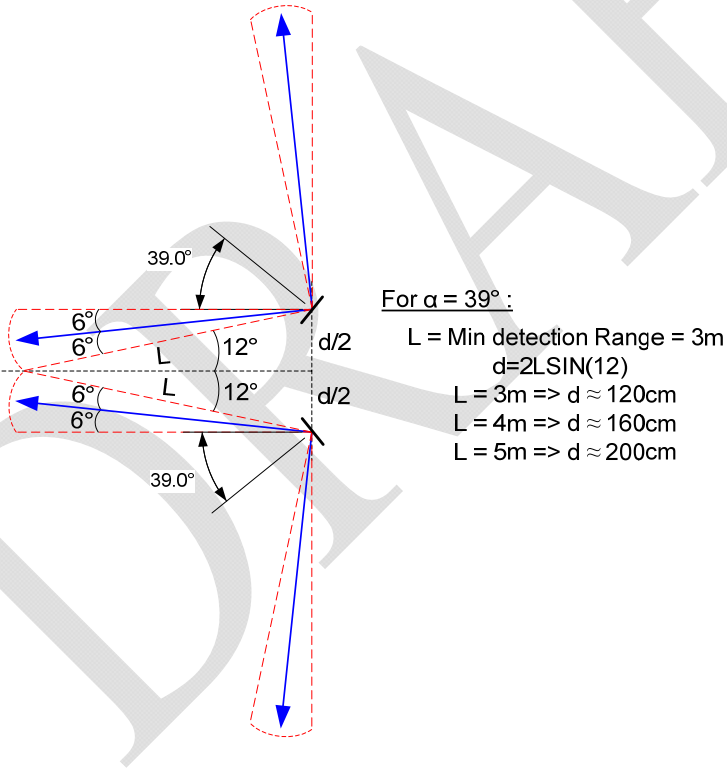
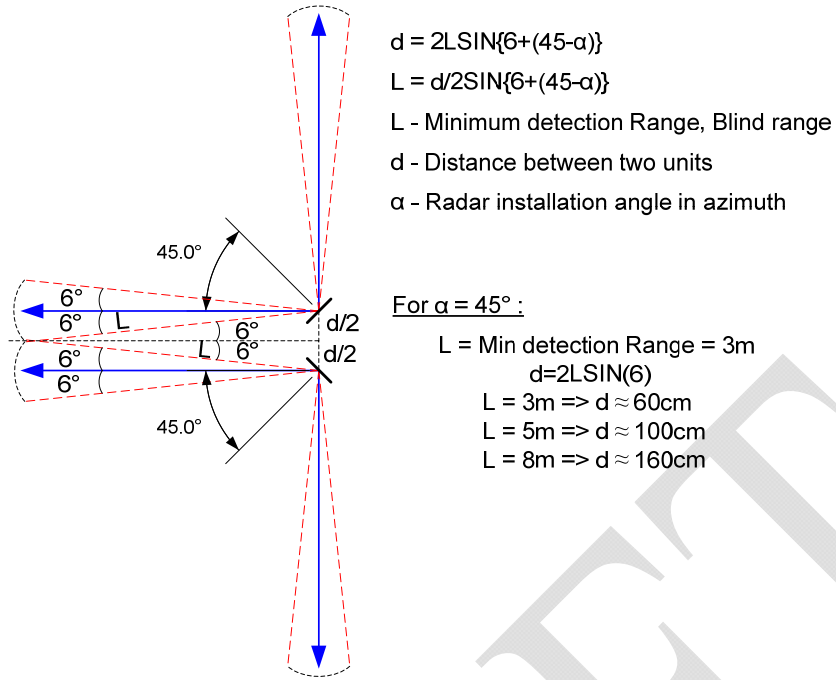

Figure 7: Two Radars 180° Azimuth Installation

This document contains proprietary information of ELTA System Ltd.

8. COMPONENTS INTERCONNECTION

The following illustration depicts the ELM-2114 System basic interconnection.

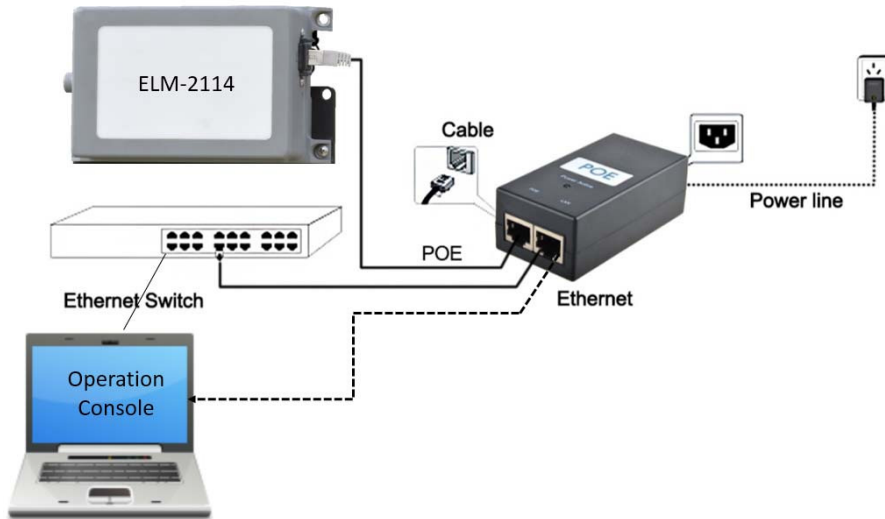

Figure 8: Components interconnection

The ELM 2114 connection to the operation console can be established, using a direct network connection or through a network switch.

9. SAFETY INSTRUCTIONS

9.1. General

This device complies with FCC Rules Part 15. Operation is subject to two conditions: (1) This device may not cause harmful interference, and (2) this device must accept any interference that may be received or that may cause undesired operation.

NOTE:

This equipment has been tested and found to comply with the limits for a Class B digital device, pursuant to part 15 of the FCC Rules. These limits are designed to provide reasonable protection against harmful interference in a residential installation. This equipment generates, uses and can radiate radio frequency energy and, if not installed and used in accordance with the instructions, may cause harmful interference to radio communications. However, there is no guarantee that interference will not occur in a particular installation. If this equipment does cause harmful interference to radio or television reception, which can be determined by turning the equipment off and on, the user is encouraged to try to correct the interference by one or more of the following measures:

- Reorient or relocate the receiving antenna.
- Increase the separation between the equipment and receiver.
- Connect the equipment into an outlet on a circuit different from that to which the receiver is connected.
- Consult the dealer or an experienced radio/TV technician for help.

Changes or modifications to this equipment not expressly approved by the party responsible for compliance (ELTA Ltd.) could void the user's authority to operate the equipment.

9.2. Electrical Safety

Care and precaution should be taken when dealing with the power accessories parts of the radar such as POE dealing with 110/220 VAC supply voltage.

The POE PS should be safety approved according to IEC/EN 60950-1, limited to 15W and considered as LPS.

9.3. RADHAZ Safety

The following graph shows that according to IAI ELTA standards, there is no required safe distance from the Radar in operation mode.

The Graph can be used for comparison with any other standard.

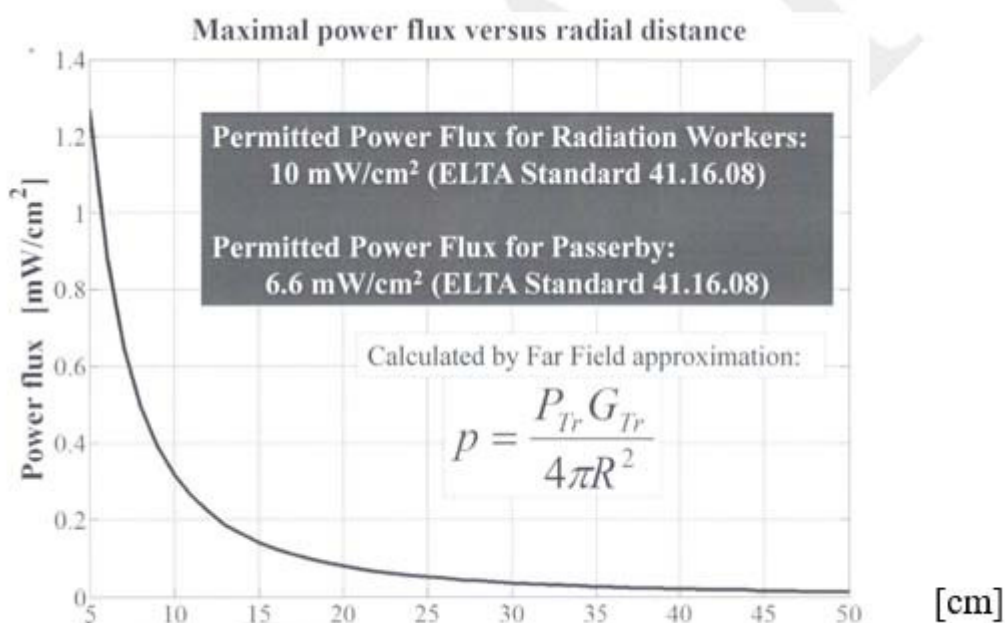

Figure 9: Radiation Power Vs. Radial Distance

This document contains proprietary information of ELTA System Ltd.

10. POWER REQUIREMENTS

The power supply must be PoE 802.3at Power Injector.

Power input: 48 ÷ 57 VDC 12-15W [Max]

The PoE should be limited to max 15W

Property	802.3at Type 2 PoE parameters
Maximal Power required by RADAR (PD)	25.50 W
Maximum power delivered by PSE	34.20 W
Voltage range (at PSE)	48.0–57.0 V
Voltage range (at RADAR)	30–57.0 V
Maximum current	600 mA per mode
Maximum cable resistance	12.5 Ω (Category 5)
Power management	Four power class levels negotiated at initial connection or 0.1 W steps negotiated continuously
Derating of maximum cable ambient operating temperature	5°C with one mode (two pairs) active
Supported cabling	Category 5
Supported modes	Mode B

11. RECOMMENDED 20[M] CABLE [CAN BE PURCHASE SEPARATELY]

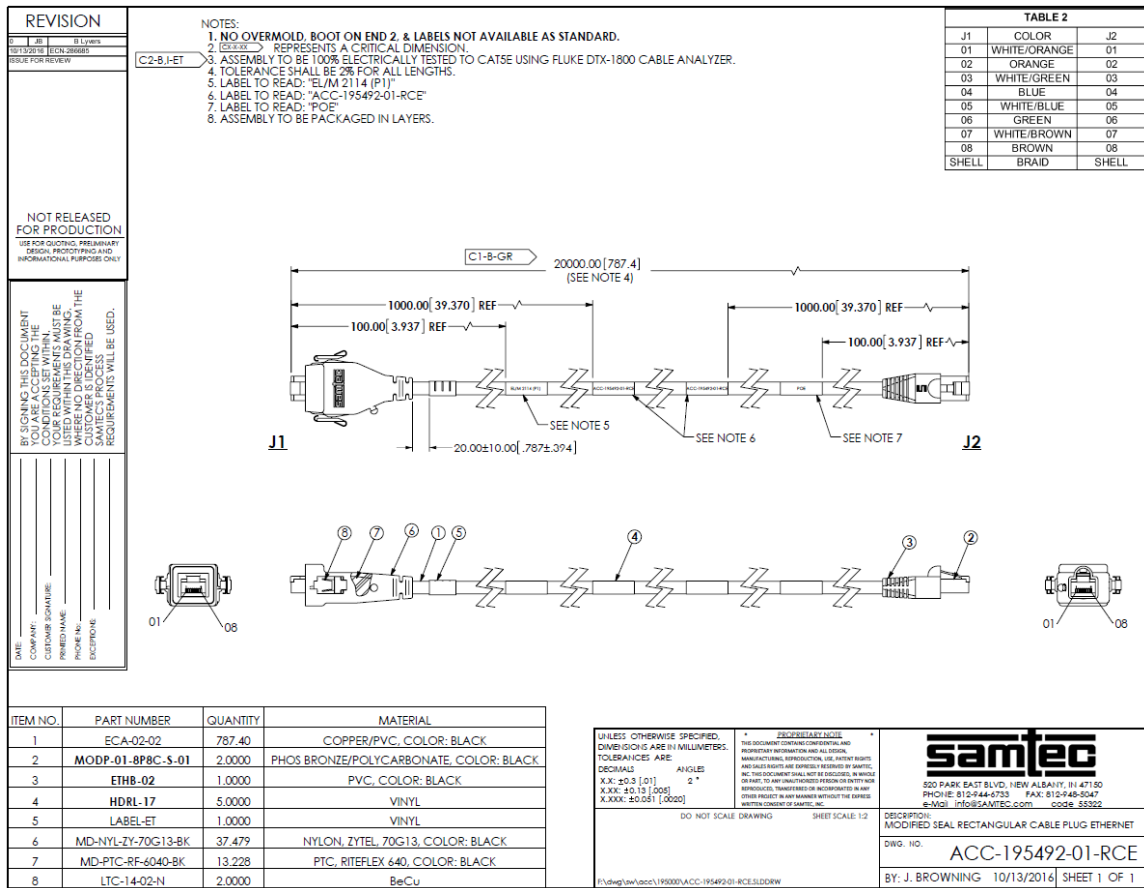

Figure 10: Network Cable