

Sono-Trak™ Doppler *Ultrasonic Flow Meter*

April 2004 5707070-A

User Manual

EMCO PRODUCTS



COPYRIGHT

This manual and the information contained herein is the proprietary property of Advanced Energy Industries, Inc.

No part of this manual may be reproduced or copied without the express written permission of Advanced Energy Industries, Inc. Any unauthorized use of this manual or its contents is strictly prohibited. Copyright© April 2004 Advanced Energy Industries, Inc. All Rights Reserved.

DISCLAIMER AND LIMITATION OF LIABILITY

The information contained in this manual is subject to change by Advanced Energy Industries, Inc. without prior notice. Advanced Energy Industries, Inc. makes no warranty of any kind whatsoever, either expressed or implied, with respect to the information contained herein. Advanced Energy Industries, Inc. shall not be liable in damages, of whatever kind, as a result of the reliance on or use of the information contained herein.

INTERPRETING THE MANUAL

The following sections explain the document type conventions and the danger, warning, and caution boxes that provide information about the specific levels of hazard seriousness.

TYPE CONVENTIONS

Please note the following type conventions:

- Pin and signal names appear in capitalized italics (*POWER_ON*).
- New terms appear in italicized text.
- Unit labels (switches, indicators, and so on) appear in boldface text (**ECHO**).
- Commands (**162**) and command names (**set point**) appear in boldface, lowercase text.

CAUTION AND ATTENTION BOXES



This symbol represents important notes concerning potential harm to people, this unit, or associated equipment. Advanced Energy® includes this symbol in Warning, Caution, and Attention boxes to identify specific levels of hazard seriousness.



WARNING:

This box identifies hazards or unsafe practices that could result in personal injury.



CAUTION:

This box identifies hazards or unsafe practices that could result in product or property damage.



Attention:

This box identifies important information. It calls attention to a procedure, practice, or condition which is important to highlight

TRADEMARKS



ADVANCED ENERGY is a registered trademark of Advanced Energy Industries, Inc.

Advanced Energy® is a registered trademark of Advanced Energy Industries, Inc.

AE® is a registered trademark of Advanced Energy Industries, Inc.

Sono-Trak™ is a trademark of Advanced Energy Industries, Inc.

Dow Corning® is a registered trademark of Dow Corning Corporation.

EMCO Flow Systems is a brand of Advanced Energy Industries, Inc.

Novagard® is a registered trademark of Foam Seal, Inc./ NSCG, Inc.

G661™ is a trademark of Foam Seal, Inc./ NSCG, Inc.

Swagelok® is a registered trademark of Swagelok Company

CUSTOMER FEEDBACK

Advanced Energy's technical writing staff has carefully developed this manual using research-based document design principles. However, improvement is ongoing, and the writing staff welcomes and appreciates customer feedback. Please send any comments on the content, organization, or format of this user manual to:

- tech.writing@aei.com

To order a manual, please contact Technical Support:

- support@emcoflow.com

For more EMCO Flow brand product line information, visit the EMCO website:

- www.emcoflow.com

Table of Contents

Chapter 1: Introduction and Theory of Operation

Introduction	1-1
Features of the Sono-Trak™ Doppler Ultrasonic Flow Meter	1-1
Components of the Sono-Trak™ Doppler Ultrasonic Flow Meter System ..	1-2
Electronics Enclosure and Display Panel	1-2
Transducers and Cabling	1-2
Theory of Operation	1-2
Sonic Reflectors	1-3
Accuracy	1-3
Summary	1-3
Applications	1-4

Chapter 2: Installation and Operation

Before Installing the Unit	2-1
Unpacking the Unit	2-1
Included Equipment	2-1
Tools Required for Installation	2-2
Pre-installation Procedures and Checks	2-2
Determining if Your Process/Installation is Right for a Doppler Flow Meter	2-3
Assessing Particles or Air Bubbles	2-4
Fluctuations in Flow Content	2-4
Process Changes	2-4
Assessing Pipe Material and Condition	2-5
Assessing Flow Profile	2-5
Straight Run Requirements	2-5
Transducer Placement	2-7
Sono-Trak Transit Time Ultrasonic Flow Meters	2-9
Installation Procedures	2-9
Mounting and Connecting the Transducers	2-9
Mounting and Connecting Power to the Electronics Enclosure	2-13
Operation	2-15
Display Panel	2-15
LEDs	2-16
First Time Operation	2-17
If You Experience Unstable Readings	2-20
Advanced Configuration Options	2-20
Before Setting Advanced Parameters	2-22

Setting Advanced Parameters	2-22
Normal Operation	2-25
Portable Battery Operation (Portable Units Only)	2-25

Chapter 3: Troubleshooting and Customer Support

Troubleshooting the Unit	3-1
Flow Meter Troubleshooting Tables	3-2
Status of Unit Power	3-2
Status of Echo LED: Off	3-3
Status of Echo LED: Flashing	3-5
Status of Flow Reading: High or Low	3-6
Status of Flow Reading: Erratic	3-8
Additional Troubleshooting Information	3-9
Echo LED Light Considerations	3-9
Suspended Particle Test For Doppler Signals	3-10
EMCO Flow Systems Support	3-11
Returning Units for Repair	3-12
Warranty	3-12
Authorized Returns	3-13
Warranty Statement	3-13

Chapter 4: Specifications and Reference Information

Performance Specifications	4-1
Physical Specifications	4-2
Functional Specifications	4-3
Dimensional Drawings	4-6
Electronics Enclosure Dimensions	4-6
Clamp-On Transducer and Digitizer Dimensions	4-8
Reference Information	4-8
Standard Pipe Data	4-9
Velocity Conversion Tables	4-12

Introduction and Theory of Operation

INTRODUCTION

The Sono-Trak™ Doppler ultrasonic flow meter provides an accurate and easy-to-use measuring system for high-solid fluid flow through pipes 1/2 inch to 300 inches (outside diameter). The Doppler flow meter is well suited for flow measurement applications such as sludges, slurries, aerated liquids, sewage, dredges, pulp, plastics, and activated sludges. The Doppler flow meter features clamp-on transducers and a rugged NEMA 4X enclosure, and is a long-term, maintenance-free solution for your high-solid flow measurement requirements.

Features of the Sono-Trak™ Doppler Ultrasonic Flow Meter

The Doppler flow meter features:

- AC or DC operation
- A smart LCD screen featuring high-resolution, 32 character, 2-line alphanumeric providing rate and totalization simultaneously—in metric and English units
- Splash proof NEMA 4X case protected from water and caustic chemicals
- Easy configuration for set up and operation with on-screen prompting, quick scrolling menus, display panel keypad, and color coded LEDs
- Clamp-on transducers
- Analog current output scaled 4 mA to 20 mA for external indication
- Separate high and low alarm outputs with LED status indication
- Extended cable distance from transducers to electronics enclosure
- High accuracy
- Wide pipe diameter range
- Maintenance-free modular construction simplifying field service

Components of the Sono-Trak™ Doppler Ultrasonic Flow Meter System

A typical Doppler flow meter system is comprised of an electronics enclosure (with a display panel), a digitizer, and two clamp-on transducers.

ELECTRONICS ENCLOSURE AND DISPLAY PANEL

The display panel in the electronics enclosure features an easy-to-read LCD screen, a keypad, and LEDs to interface with the flow meter. The Doppler flow meter can be wall mounted for permanent installation or a portable option is also available.

TRANSDUCERS AND CABLING

The Doppler flow meter is configured with clamp-on transducers. When installed, the transducers sense fluid flow through a pipe and send this information to the system electronics. The electronics then convert, transmit, and display the received data.

The clamp-on transducers allow you to install the Doppler flow meter without shutting down flow and are ideal for smooth, clean pipe walls. The transducers and the digitizer are NEMA 6-rated and fully submersible. However, for continuous submersion, the transducers and the digitizer need to be specially encapsulated to prevent corrosion. Contact [“EMCO Flow Systems Support” on page 3-11](#) for information on configuring your meter for continuous submersion.

The standard cable length between the electronics enclosure and the transducers is 25 feet. Custom cable lengths up to 5000 feet are available. See [“EMCO Flow Systems Support” on page 3-11](#) for contact and ordering information.

THEORY OF OPERATION

The Sono-Trak™ Doppler ultrasonic flow meter measures flow velocity by sensing signals from reflective materials within a liquid and measuring the frequency shift due to the motion of these reflective materials. The Doppler effect states that the received frequency is a function of the transmitted frequency and the relative motion between transmitter and the receiver.

The classic example of the Doppler effect is the train whistle increasing in pitch to the listener at the station as the train approaches, then decreasing in pitch as the train moves away from the station. To the person riding on the train, the pitch remains the same. The increasing pitch is due to phase-front compression and the decreasing pitch is due to phase-front expansion. The Doppler flow meter uses this effect to measure the velocity of a liquid through a pipe wall.

Sonic Reflectors

The Doppler flow meter requires sonic reflectors in order to operate. These reflectors may consist of particles or air bubbles within the flow to be measured. Your readings may vary slightly with changes in concentration or size of these reflectors as well as the pipe condition and size.

Note: Glycerin is the only known industrial liquid today that is not sonically conductive.

The Doppler flow meter uses two similar transducers to sense flow in a pipe. These transducers are mounted on the outside of a pipe. This configuration presents no obstruction to flow, and will not cause associated pressure drops.

Accuracy

The Doppler flow meter output signal is linear (as opposed to square root), which means that accuracy is not a function of flow rate. Within certain application limits, the meter is ideal because it is not affected by changes of pressure within the process nor by changes of viscosity, temperature, specific gravity, sound velocity, or electrical conductivity.

Summary

The Doppler flow meter is a non-intrusive flow meter system which operates by sensing the frequency shifts of signals reflected from particles, air bubbles, or density differences within a liquid, producing a linear signal proportional to the flow of the liquid within the pipe.

- No pipe section is required to install the meter.
- The meter is not affected by changes in temperature, viscosity, specific gravity, or the speed of sound within the liquid.
- The liquid does not have to be electronically conductive.
- A minimum particle concentration of 35 ppm @ 40 micron of suspended solids or air bubbles is required.
- The reflector must have at least a 0.2% density difference than the liquid medium.
- For accurate volumetric measurement the pipe must be full at all times.
- The sensors, transducer crystals, are always coupled to the pipe with gel or epoxy.
- In order to obtain accurate measurements adequate upstream and downstream pipe runs are required. Recommended straight-run requirements from any disturbance of flow are 10 diameters upstream and 5 diameters downstream.

APPLICATIONS

Some of the materials the Sono-Trak™ Doppler ultrasonic flow meter is well-suited for measuring include:

- Ag water
- Abrasives
- Asphalts
- Concrete
- Dredge flows
- Drilling mud
- Large contaminants
- Extremely viscous substances
- Grout
- Hazardous wastes
- Municipal sludges and wastes
- Paper pulp
- Rendering products
- Reservoirs
- Rivers and streams
- Runoffs
- Sludges
- Slurries
- Suspended solids
- Most all liquids containing suspended particles or air bubbles

Installation and Operation

BEFORE INSTALLING THE UNIT

Before installing your Sono-Trak™ Doppler ultrasonic flow meter, follow the steps listed below:

1. See [“Unpacking the Unit” on page 2-1](#).
2. Make sure you have performed the [“Pre-installation Procedures and Checks” on page 2-2](#).
3. Determine if your process/installation is compatible with the requirements of Doppler flow meter. See [“Determining if Your Process/Installation is Right for a Doppler Flow Meter” on page 2-3](#).
4. Proceed to [“Installation Procedures” on page 2-9](#).

Unpacking the Unit

Unpack and inspect the unit carefully, looking for obvious physical damage. If no damage is apparent, locate and save all documentation and then proceed with the following procedures.

If you see signs of shipping damage, contact EMCO product support at Advanced Energy and the carrier immediately (see [“EMCO Flow Systems Support” on page 3-11](#) for contact information). Save the shipping container for submitting necessary claims to the carrier.

INCLUDED EQUIPMENT

[Table 2-1](#) lists the standard items that ship with Sono-Trak™ Doppler ultrasonic flow meter systems.

Table 2-1. Items shipped with the flow meter system

Fixed unit (C5F model)	Portable unit (C5P model)
<ul style="list-style-type: none"> • Electronics enclosure • Two transducers and a 25' cable (standard); custom lengths up to 5000' are available • Digitizer • Tiedown kit • Sonic coupling gel • User manual 	<ul style="list-style-type: none"> • Electronics enclosure • Two transducers and a 25' cable (standard); custom lengths up to 5000' are available • Digitizer • Tiedown kit • Sonic coupling gel • User manual • 12 V 2.2 AH battery • 110 VAC battery charger • Tote handles and side latch • Field transport case

TOOLS REQUIRED FOR INSTALLATION

- Sandpaper to clean the pipe surface to bare pipe
- Tape measure to measure pipe size

Pre-installation Procedures and Checks

Before you install your Doppler flow meter, there is a pre-install check you should perform to ensure that this is the appropriate meter to use for your application. If you encounter any difficulties during the pre-installation procedures, see [“Determining if Your Process/Installation is Right for a Doppler Flow Meter”](#) on page 2-3 before proceeding with the installation process.

To Perform the Doppler flow meter Pre-installation Check:

1. Mount the transducers side by side between 7 o'clock and 10 o'clock on the pipe (see [“Mounting and Connecting the Transducers”](#) on page 2-9 for more information).
2. If not already connected, connect the transducers to the electronics enclosure (see [“Mounting and Connecting the Transducers”](#) on page 2-9).
3. Connect AC or DC power to the flow meter (see [“Mounting and Connecting Power to the Electronics Enclosure”](#) on page 2-13).
4. Turn on the power using the switch on the display panel.
5. After the electronics enclosure powers up and the front display panel lights up, press soft key 1 to select **FPS** (feet per second).
6. Estimate your expected flow rate and compare it to the reading in feet per second on the display panel.

- ▶ If the reading on the display panel appears to be accurate, continue to the next step.
 - ▶ If you do not see a flow reading on the LCD screen at all, or if the flow reading is much lower or higher than expected, try repositioning the transducers. If this does not help, see [“Determining if Your Process/Installation is Right for a Doppler Flow Meter”](#) on page 2-3 and consult [“Troubleshooting the Unit”](#) on page 3-1.
7. Observe the yellow **Echo** LED on the display panel.
- ▶ If the **Echo** LED is on steady, and the flow reading appears to be accurate, your Doppler flow meter is ready for operation. See [“Normal Operation”](#) on page 2-25 to configure the flow meter for operation with your system.
 - ▶ If the **Echo** LED is flashing or *not* illuminated, see [“Determining if Your Process/Installation is Right for a Doppler Flow Meter”](#) on page 2-3 and consult [“Troubleshooting the Unit”](#) on page 3-1.

DETERMINING IF YOUR PROCESS/ INSTALLATION IS RIGHT FOR A DOPPLER FLOW METER

Accurate operation of a Doppler flow meter depends upon your application and installation site. Doppler flow meters offer many advantages over other flow meter models when flows are viscous, turbulence is minimal, and piping materials are appropriate. When conditions are adverse to Sono-Trak™ Doppler ultrasonic flow meter operation, the Sonotrak™ Transit Time flow meter may offer an excellent alternative. Contact [“EMCO Flow Systems Support”](#) on page 3-11 for more information about this transit time meter.

To determine which flow meter is appropriate for your process and specific installation, consider the following:

- The presence of reflective particles in the flow
- The pipe material and condition of pipe housing the flow
- The flow profile, meaning that you are able to provide acceptable straight run requirements to ensure more accurate readings

The following sections discuss these considerations.

Assessing Particles or Air Bubbles

The ultrasonic beam from the transducer is transmitted through the pipe wall into the liquid. The particles, air bubbles suspended in the liquid, have to be large enough to act as reflectors to return the signal back to the transducer so that a measurement may be taken. It is important to understand that the ultrasonic beam from the Doppler flow meter does not penetrate air very well. A few bubbles will not affect flow meter performance, but too many bubbles may cause the meter to malfunction. See [“Suspended Particle Test For Doppler Signals” on page 3-10](#) for information on how to assess the particulate content of your flow.

Note: At a frequency of roughly 650 kHz, the minimum particle which can be sensed is 40 microns @ 35 parts per million (ppm) and at least 0.2% density difference from the liquid.

**Attention:**

The flow to be measured must always have a sufficient number of sonic reflectors of ample size in order to provide reflection of the transmitted sound. If the reflectors do not have sufficient density difference they will neither rise nor fall in the solution but remain suspended. The specific gravity will also affect the ability of a particle to reflect sound. A good example of a reflector is a sand particle or an air bubble. A poor example is algae or onion skins.

FLUCTUATIONS IN FLOW CONTENT

Wide fluctuations in flow suspended solids content can only be handled by an instrument capable of monitoring such a wide fluctuation in liquid characteristics. Extreme cases may require the use of both a transit time flow meter (such as the Sono-Trak™ model) as well as a Doppler flow meter. For example, river water may require a meter which is capable of measuring both clean and dirty liquids. Depending on conditions, the river may vary considerably in suspended solid content.

PROCESS CHANGES

Changes in the process may cause the meter to cease proper operation. For example, a Doppler meter had been operating satisfactorily for a long time in a certain installation, and then suddenly it stopped functioning. The problem was eventually traced to a particle filter that had recently been placed before the transducers, effectively eliminating the reflectors from the stream.

Process changes in the other direction are also possible. The meter responds to bubbles up to a point, but if the liquid starts to foam there may be too many air bubbles to allow the ultrasonic beam to adequately penetrate the flow stream. This may cause the Doppler flow meter to produce erroneous flow readings. Similarly, a sludge may become too dense to allow proper penetration.

Assessing Pipe Material and Condition

Doppler flow meter performance is best maximized by using piping that is sonically conductive. The Doppler flow meter assumes that the path by which the ultrasonic beam enters the pipe and returns to the transducer is ultrasonically homogenous, which means that you must use your flow meter with pipes with non-porous smooth pipe walls. Concrete-lined pipes, old or crystallized cast iron pipes, hand-wrapped fiberglass pipe, and old piping with air inclusions do not exhibit the required homogeneity. Avoid using the Doppler flow meter for flow measurement on these pipes unless proper operation is proven by the manufacturer through demonstration.

Contact “[EMCO Flow Systems Support](#)” on page 3-11 for more information on an alternate meter if your application is not suitable for the Doppler flow meter.

Note: No clamp-on meter will operate properly if the liner is not solidly attached to the pipe wall because of the probability of an air gap.

Pipe Vibration

Moderate pipe vibration does not usually adversely affect the Doppler flow meter, since the vibration of the piping is at a significantly lower frequency than the ultrasonic beam used to measure flow. However, in situations where the transducer signal strength is low because of fluid, piping, or other environmental factors, measurement accuracy may be further decreased by pipe vibration. In these situations your display panel may register flow when there is none due to the vibration. If you can not bracket the pipe to reduce vibration, you may be able to rectify the problem by relocating the transducer to a pipe location with less vibration.

Assessing Flow Profile

STRAIGHT RUN REQUIREMENTS

As with other flow meters such as vortex or magnetic flow meters, the Doppler flow meter needs a well-developed flow profile to ensure accurate flow measurement. To assure a well-developed profile, choose a measurement point on a long run of pipe—well away from elbows, valves, pumps, flanges, and other possible sources of turbulence.

The ideal placement of the Doppler flow meter is with 20 diameters of straight run upstream and 10 diameters of straight run downstream between the transducers and any disturbance of the flow. Most typical flow meter applications use 10 diameters of straight run upstream and 5 diameters downstream from any disturbance of the flow.

However, when the measured fluid is too clean to provide the proper number of reflective particles, one may position the transducer near the pump or source of turbulence in such a manner as to obtain stable readings in a continuous flow full pipe situation. Using a transit time meter may be another viable option if the Doppler flow

meter is not performing ideally. A point to remember is that turbulence is a non-linear function of flow, so turbulence can create reflected signals. Interpret readings near turbulent flows with caution.

Sources of turbulence are elbows, flanges, valves, orifices, wedges, pumps, pipe openings, and pipe irregularities (rust, corrosion, and buildup). Always avoid vertical pipe runs (especially downhill pipe runs).

Table 2-2. Flow meter distance from turbulence and reading accuracy

Upstream	Downstream	% Accuracy
20 diameters	10 diameters	±1% to 3% of full scale
10 diameters	5 diameters	±3% to 5% of full scale
5 diameters	2 diameters	±5% to 10% of full scale

Note: Accuracy is dependant on flow profile, and is related to the percentage of sound reflectors and their size variation and distribution.

[Figure 2-1](#) provides straight run examples.

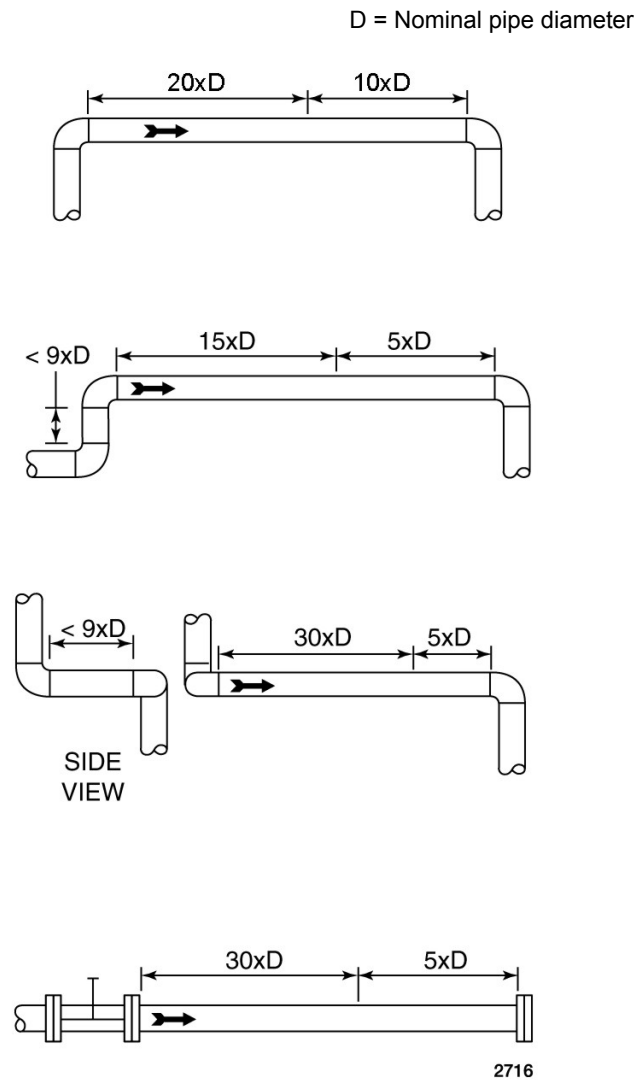

Figure 2-1. Straight run examples

TRANSDUCER PLACEMENT

You should always avoid measuring liquids in vertical downward flows with any flow meter. In the case of Doppler flow meters, vertical downward flows cause erroneous readings by introducing air bubbles. Excessive air bubbles attenuate the measurement signal by hampering penetration of the ultrasonic beam into the fluid. Bubbles will tend to rise against the flow, and since the Doppler flow meter is capable of totalizing in both directions, this will cause erroneous flow measurements as the meter factors in the backward flow of the bubbles. Additionally, in vertical flows it may be difficult to keep the pipe full, allowing pockets of air into the pipe. This will drastically reduce the transducer's ability to penetrate the flow and produce a readable signal.

When the Doppler transducers are mounted on a horizontal pipe, care should be taken to mount them in the 7 o'clock and 10 o'clock positions (with the top of the pipe—the side furthest from the Earth—corresponding to the 12 o'clock position). If the transducer is mounted on the bottom of the pipe, settling particles may attenuate the signals by introducing an additional sonic barrier. Also, air may agglomerate at the top of the pipe. Since the ultrasonic frequencies used will not penetrate air efficiently, the signal will be heavily attenuated so that the meter will not be able to render accurate results.

Horizontal Pipe Mounting

The recommended placement of the Doppler transducers is a horizontal section of piping. [Figure 2-2](#) provides horizontal mounting examples.

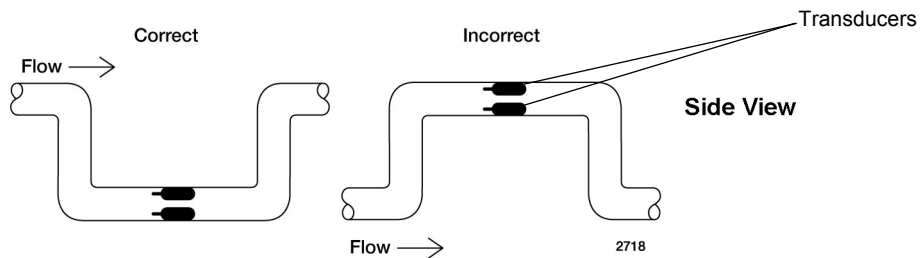

Figure 2-2. Horizontal pipe mounting examples

Vertical Pipe Mounting

Measuring flow at a vertical pipe run is *not* recommended. If measuring flow in a vertical run can not be avoided, we recommend you measure at a point where the direction of flow through the pipe is upwards to help ensure the pipe will remain full at all times ([Figure 2-3](#)). However, measuring flow even with an upward vertical pipe run will not address all the problems associated with this configuration.

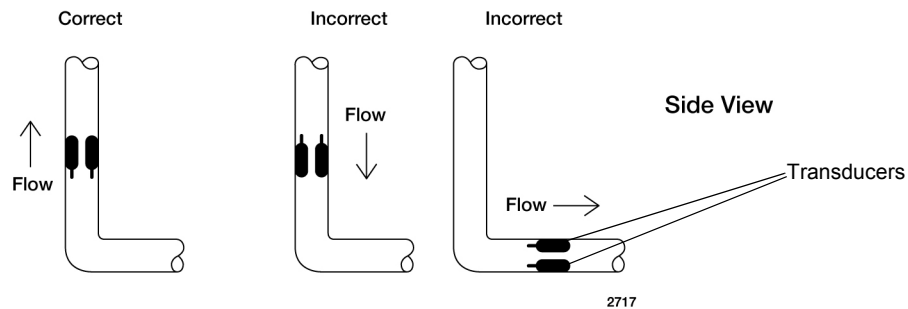

Figure 2-3. Vertical pipe mounting examples

Sono-Trak Transit Time Ultrasonic Flow Meters

In the event the flow to be measured does not contain the minimum required particle size and/or parts per million count, and the transducer will not read, you may want to consider the Sono-Trak™ Transit Time ultrasonic flow meter for your application. Contact an EMCO sales representative with your flow meter application questions. See [“EMCO Flow Systems Support” on page 3-11](#) for contact information.

INSTALLATION PROCEDURES

After you have performed the pre-install check and determined that the Doppler flow meter will work for your application, follow these steps to install your meter.

To Install the Sono-Trak™ Doppler Ultrasonic Flow Meter:

1. Mount and connect the transducers (see page [2-9](#))
2. Mount and connect power to the electronics enclosure (see page [2-13](#))
3. Turn on power to the electronics enclosure using the switch on the display panel and follow display panel for meter set up (see [“Operation” on page 2-15](#) for more information on configuring your meter for operation)

Mounting and Connecting the Transducers

The clamp-on transducers are NEMA 6-rated and fully submersible. However, if your system requires that the transducers and the digitizer be continuously submerged, they need to be specially encapsulated to prevent corrosion. Contact [“EMCO Flow Systems Support” on page 3-11](#) for information on configuring your flow meter components for continuous submersion.

To Mount the Clamp-On Transducers to the Pipe:

1. Ensure the pipe surface is clean. Use sandpaper to remove all paint and scale from the pipe surface if necessary.
2. Apply sonic gel to the transducer lenses. For best results in most weather conditions and heat, use Dow Corning® High Vacuum Grease or the supplied Novagard® grease G661™.



Attention:

Always apply sonic gel to the transducer lenses before placing on the pipe. The sonic gel must be used to transmit the energy from the transducer crystals through the pipe wall and into the flow to be measured.

- Place the transducers side by side between 7 o'clock and 10 o'clock on the pipe as shown in [Figure 2-4](#). Place the transducers flush to the pipe, facing the same direction. See [Figure 2-5](#) for an example.

Note: Be careful with transducer placement. Air bubbles near the top of the pipe or sediment on the bottom of the pipe can hinder successful flow readings. Place the transducers as shown in [Figure 2-4](#).

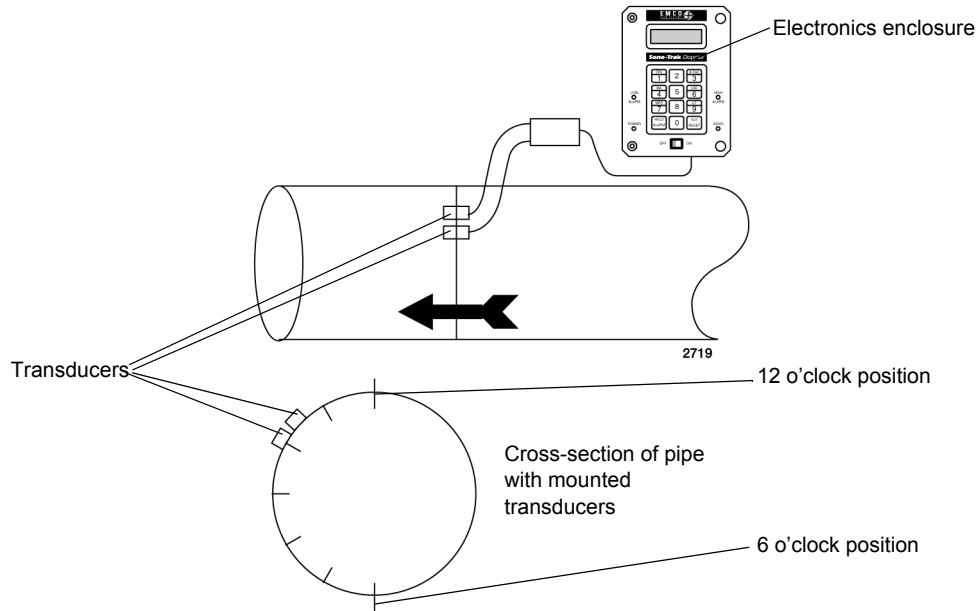

Figure 2-4. *Clamp-on transducer placement*

- Use the supplied chain and bungee cord to strap the transducers in place, securing them tightly to the pipe. [Figure 2-5](#) provides an example of two properly mounted clamp-on transducers.

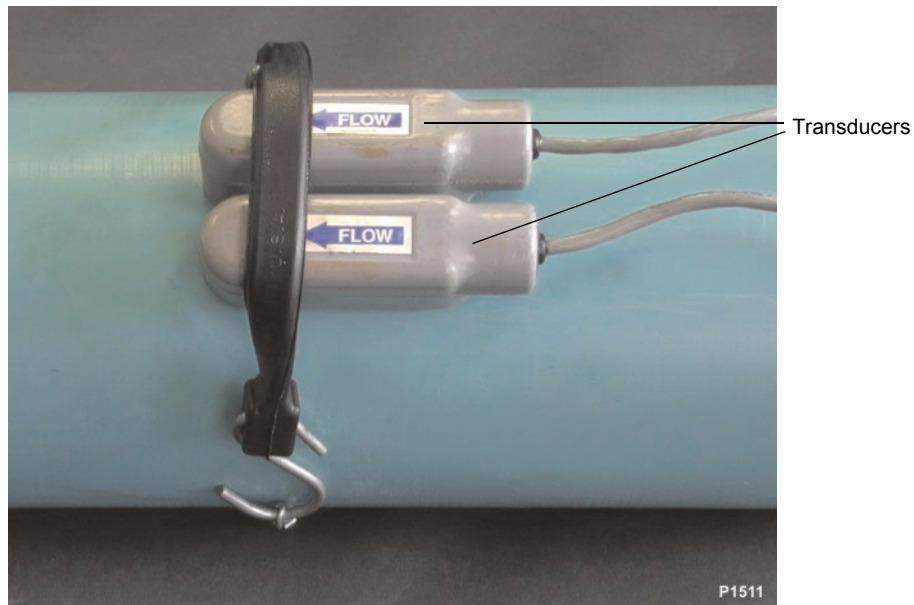

Figure 2-5. Clamp-on transducers secured with a bungee and chain

To Connect the Transducers to the Electronics Enclosure:

1. Ensure AC or battery (DC) input power is turned off.
2. Connect the transducer cable to the electronics enclosure by routing the cable through the appropriate opening (see [“Bottom view of the electronics enclosure” on page 4-7](#) for location of cable access openings). Use a cable gland and a cable backing nut to securely fasten the transducer cable to the electronics enclosure.
3. Connect the transducer wires to the processor board as shown in [Figure 2-6 on page 2-12](#) for correct placement. The transducer 4-wire connection is as follows:
 - ▶ White = Digital signal output (0 V to 12 V pulse train)
 - ▶ Green = Echo good logic signal (when used)
 - ▶ Red = 12 VDC to 15 VDC at 100 mA nominal power in
 - ▶ Black = Ground / Common

Note: Do not connect bare shield wire to black (common / ground)

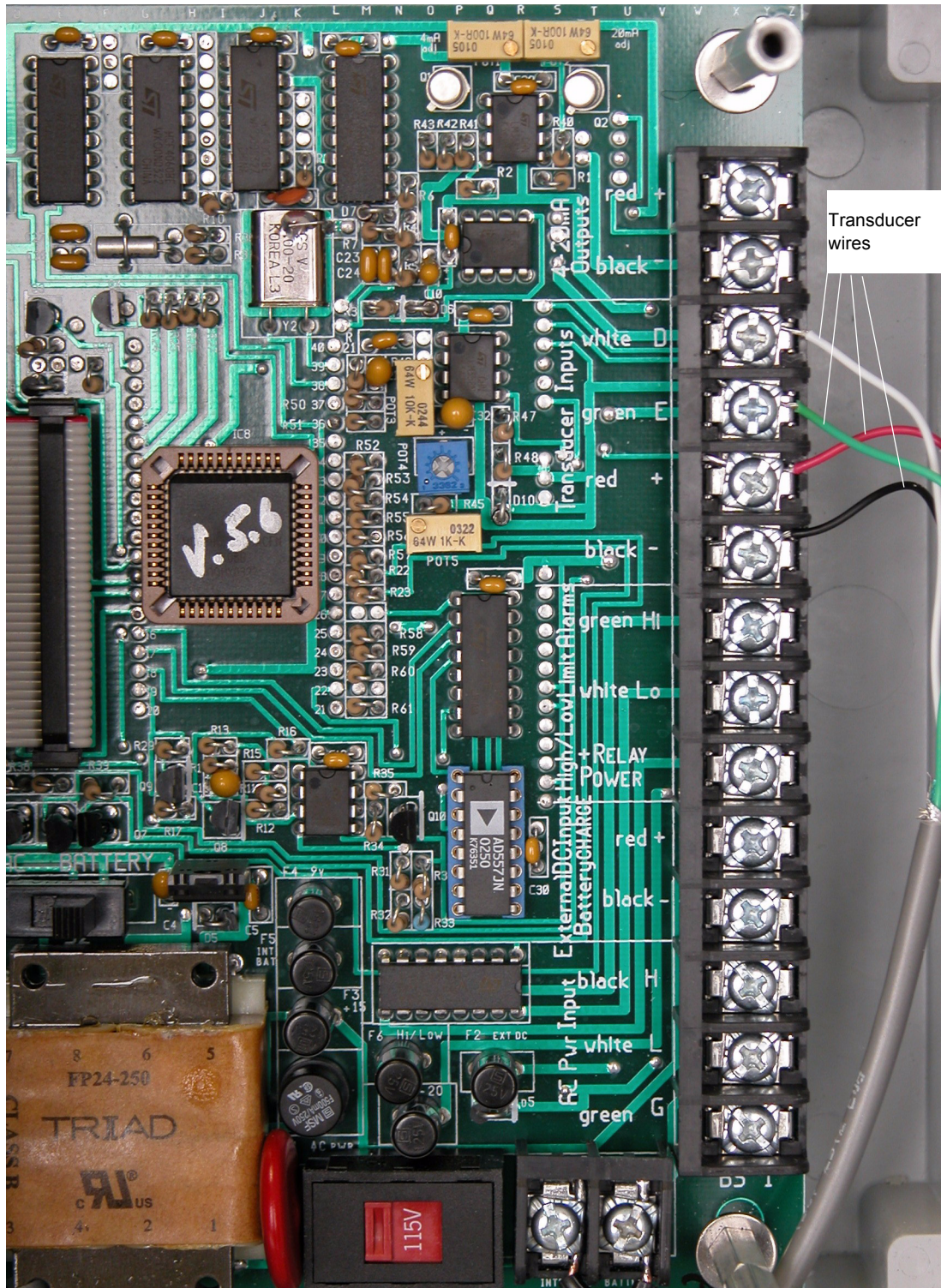

Figure 2-6. Main electronics board connections

- Continue with [“Mounting and Connecting Power to the Electronics Enclosure”](#) on page 2-13.

Mounting and Connecting Power to the Electronics Enclosure

The fixed Doppler flow meter model electronics enclosure is wall mounted for permanent installation. The portable meter model does not need to be mounted.

To Mount the Fixed Electronics Enclosure:

- Locate and install the four mounting feet supplied with your system to the base of the electronics enclosure.

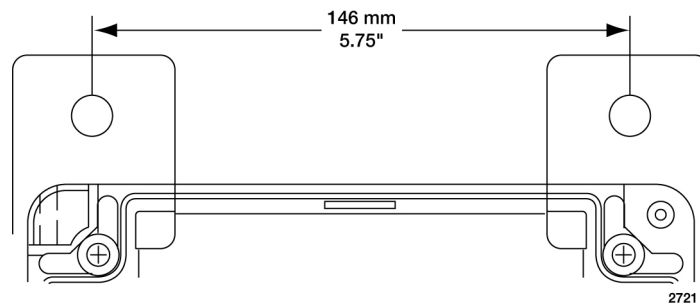

Figure 2-7. Wall mounting feet of the electronics enclosure

- Using the reinforced holes in the mounting feet, securely mount the electronics enclosure to the wall.

To Connect Input Power to the Electronics Enclosure:

Note: You can either use AC power or DC/ battery power to operate your Doppler flow meter.

- If you are using AC power:
 - ▶ If not already connected, supply input power to the electronics enclosure by routing the power cable through the appropriate opening (see [“Bottom view of the electronics enclosure”](#) on page 4-7).
 - ▶ If needed, connect the AC power cable wires to the **AC Pwr Input (117/220 VAC)** section of the processor board using [Figure 2-6](#) and [Figure 2-8](#) as a guide, making sure to properly connect ground.
 - ▶ Use a cable gland and a cable backing nut to securely fasten the input power cable to the electronics enclosure.
 - ▶ Verify that the **A/C Select** switch is set for the proper voltage (115 VAC or 230 VAC)
 - ▶ Move the **AC/ Battery (DC)** switch to the AC side. See [Figure 2-8](#) for switch locations.

▶ Plug AC power into the appropriate outlet.

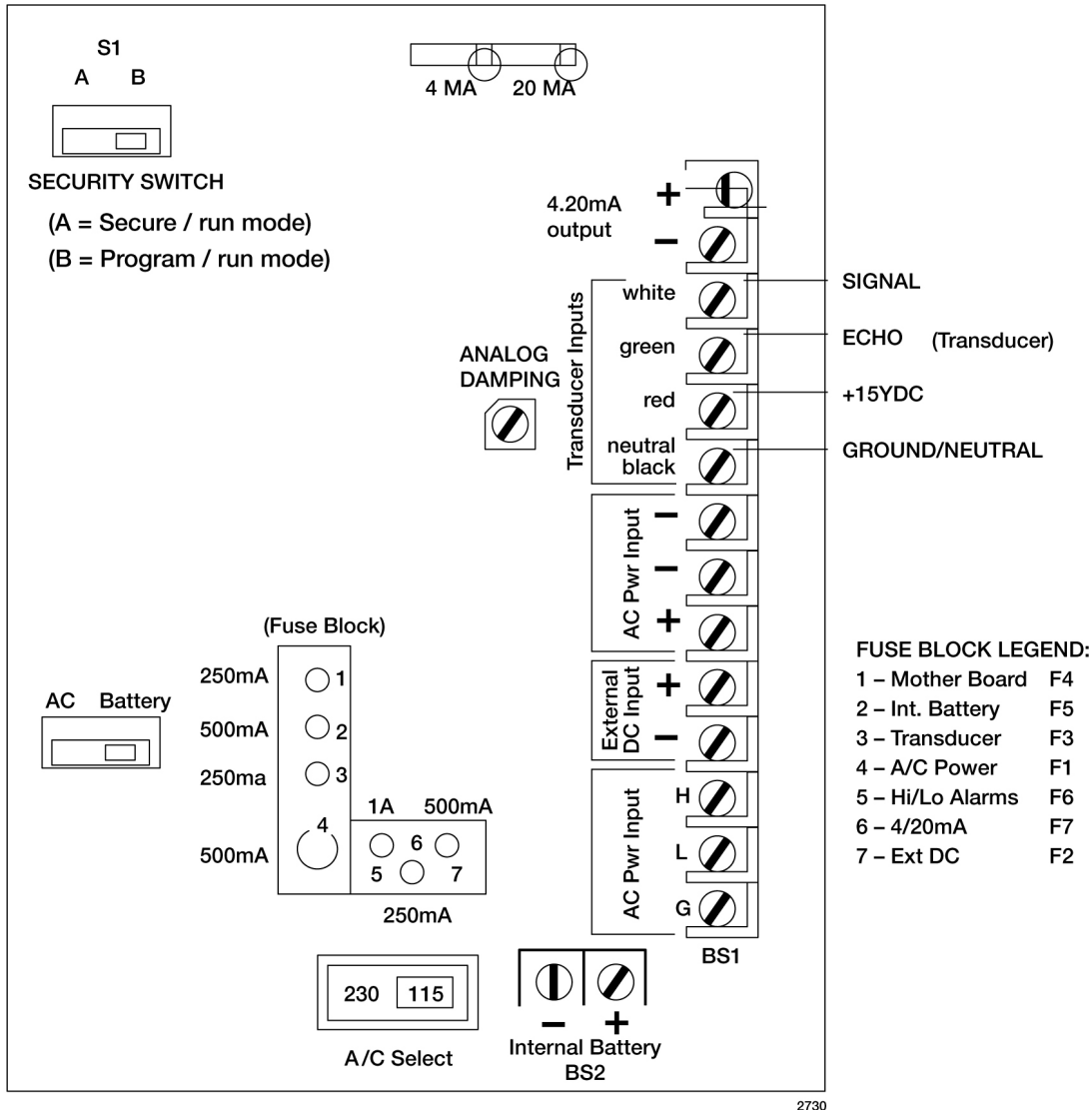

Figure 2-8. Another view of processor board connections

2. If you are using DC/ battery power:

- ▶ If not already connected, supply input power to the electronics enclosure by routing the power cable through the appropriate opening (see “[Bottom view of the electronics enclosure](#)” on page 4-7).
- ▶ If needed, connect the DC power cable wires to the **Internal Battery** section of the processor board using [Figure 2-6](#) and [Figure 2-8](#) as a guide.
- ▶ Use a cable gland and a cable backing nut to securely fasten the input power cable to the electronics enclosure.

- ▶ Move the **AC/ Battery** switch to the **Battery** (DC) side. See [Figure 2-8](#) for the switch location.
 - ▶ Plug the battery in to the power cable. For information on charging your battery, see [“Portable Battery Operation \(Portable Units Only\)”](#) on page 2-25.
3. Continue on to [“First Time Operation”](#) on page 2-17.

OPERATION

The following sections describe the display panel in the electronics enclosure, first time operation, and normal operation of your Doppler flow meter.

Display Panel

The display panel in the Doppler flow meter electronics enclosure provides an interface for monitoring and controlling the flow meter. The high resolution 2-line (16-digits per line) display shows operating information and configuration menu prompts. You may use the keypad to make selections when prompted by the configuration menu prompts.

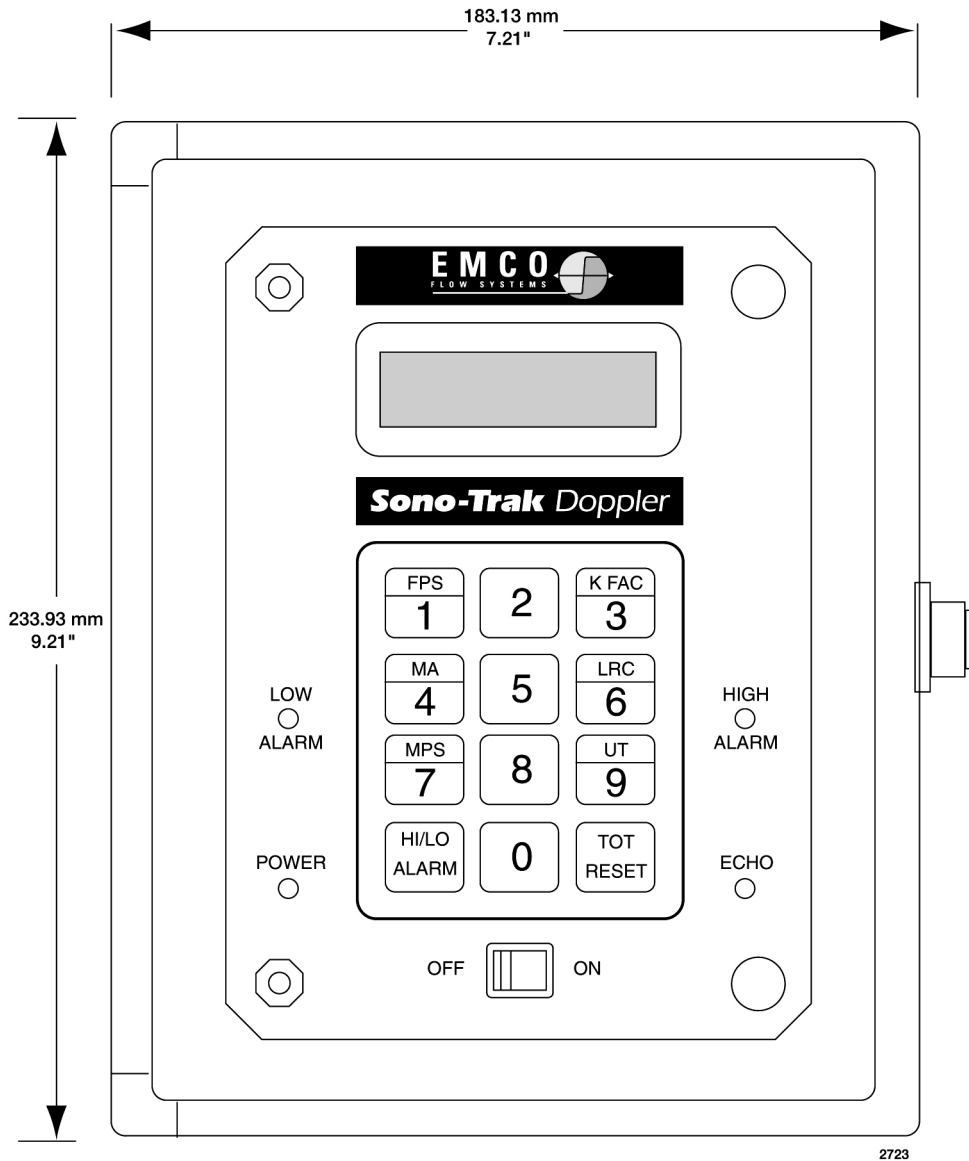

Figure 2-9. Display panel

LEDS

If your Doppler flow meter is working properly with your system, when you power up the flow meter you should see the green **Power** LED and the yellow **Echo** LED illuminate. If this is not the case, consult the table below and see [“Troubleshooting the Unit”](#) on page 3-1.

Table 2-3. LED conditions and indications

LED	Condition	Indication
Power (Green)	Off	Power is <i>not</i> available to the unit. If you have tried to power up your unit and this light is off, see “Troubleshooting the Unit” on page 3-1.
	Illuminated steady	Power is available to unit. Proceed with normal operation.
Echo (Yellow)	Off	No echo signal. Consult “Troubleshooting the Unit” on page 3-1.
	Flashing	Echo signal is weak. Consult “Troubleshooting the Unit” on page 3-1.
	Illuminated steady	Echo signal is good. Proceed with normal operation.
Alarm High or Low (Red)	Off	No alarm conditions exist. Proceed with normal operation.
	Illuminated steady	An alarm condition exists. Your system is running at high or low flow. Adjust your flow levels or consult “Troubleshooting the Unit” on page 3-1.

First Time Operation

Once you have successfully completed installation of the Doppler flow meter, you are ready to configure your unit for operation using the front panel in the electronics enclosure.

**Attention:**

If your display flashes **LOW BAT** at any time during setup or programming, consult [“Status of Unit Power” on page 3-2](#) for troubleshooting information.

Note: If you are switching from battery (DC) power to AC power and the A/C Select switch selection does not match your incoming power level, you may see a **LOW BAT** warning in the front panel display. Adjust the A/C Select switch to the correct incoming power level (115 VAC or 230 VAC), and this warning should disappear.

To Operate Your Doppler Flow Meter for the First Time:

1. Complete all the steps in [“Before Installing the Unit” on page 2-1](#).
2. Complete all the steps in [“Installation Procedures” on page 2-9](#).
3. Turn on power and observe the display panel LCD. The display will show the model name and number of the unit.
4. Following the prompts presented by the display panel LCD, and making your entries using the keypad, configure your unit for operation.
 - ▶ The LCD screen displays **SELECT RATE**. Select the unit of measure for rate display:

Table 2-4. Rate selection

Key	Selection	Definition
1	FPS	Feet per second
2	GPM	Gallons per minute
3	CFS	Cubic feet per second
4	MGD	Million gallons per day
5	MPS	Meters per second
6	LPS	Liters per second
7	CMS	Cubic meters per second
8	< = >	Use this key to move between rate screens

If you select FPS, the flow meter will automatically begin measuring flow in feet per second. If you select keys 2 through 7, the LCD screen will ask that you enter your pipe ID in inches. See [“Standard Pipe Data” on page 4-9](#) to estimate your pipe ID.

After you enter your pipe ID, the LCD screen will then display **SELECT TOTALIZER**. Select the unit of measure for totalizer display:

Table 2-5. Totalizer selection

Key	Selection	Definition
1	GAL	Gallons
2	CU FT	Cubic feet
3	AC FT	Acre feet
4	MG	Millions of gallons
5	LTRS	Liters
6	CM	Cubic meters
8	< = >	Use this key to move between totalizer selection screens

Your Doppler flow meter is now configured to measure flow per the parameters you have set. After you set the flow reading parameters you need for your system, you can secure these settings so they are saved in the event of power loss to the electronics enclosure.

Note: To clear the rate and totalizer parameters you have set, simply switch the power off using the on/ off switch on the display panel. Until settings are saved using the security switch, turning off power clears all previously set parameters. When you turn on power again, the LCD screen will prompt you to restart programming.

To Save Your Programmed Flow Reading Settings Using the Security Switch:

1. Complete setting the flow reading parameters (see [“First Time Operation” on page 2-17](#) to set parameters).
2. Unscrew the face of the display panel to expose the processor board by turning both white plastic screws on the right side of the face of the display panel counterclockwise at the same time.
3. The security switch (called “S1” on the electronics board) is located in the upper left corner of the processor board, See [Figure 2-8](#) to find the location of this switch. While programming, the switch was on the “B” side (Program/ run mode).
4. To save your new settings, move the security switch on the processor board to the “A” side (Secure/ run mode). This switch ensures your settings will be saved in the event of power loss.
5. Be sure to close and resecure the face of the display panel when you are finished. Carefully rethread the screws clockwise simultaneously.

Note: If you need to change your programming, reopen the electronics enclosure and unscrew the display panel to expose the processor board. Slide the security switch to the “B” side (Program/ run mode). Once your new selections are

complete, you can then return the switch to the “A” side to preserve your new settings. Again, be sure to close and carefully resecure the face of the display panel when you are finished.

If you wish to further customize your flow meter system for operation in your process, continue on to [“Advanced Configuration Options” on page 2-20](#).

IF YOU EXPERIENCE UNSTABLE READINGS

A steady display and solid illuminated **Echo** lamp indicates a good signal. An erratic display and/or a flashing **Echo** lamp indicates a poor signal. Reposition the transducer heads until readings are steady and the **Echo** lamp is illuminated solid or select another position to mount the sensors. Possible reasons for poor signals are:

- Partially full pipe
- Extreme aeration
- Insufficient suspended particles (minimum particle size and concentration are 40 microns at 35 ppm and greater than 0.2% density difference)

Any fluids with particle size/concentration less than the requirement listed above should be measured with a transit time flow meter and not a Doppler flow meter.

- Extreme turbulence
- Interference from electric motors or motor controllers

If your meter readings do not stabilize, see [“Troubleshooting the Unit” on page 3-1](#) and [“Echo LED Light Considerations” on page 3-9](#) for further assistance.

Advanced Configuration Options

The display panel keypad has a secondary menu for advanced configuration options (the keypad toggle menu). You may want to use this menu to set Analog output or to select alarm setpoints. To access the secondary menu, you must press and hold the keypad key for one second, and then when the display changes release the key. To exit, press and hold the key again for one second and then release.

- [Figure 2-10 on page 2-21](#) provides a visual representation of the toggle menu.
- [Table 2-6](#) lists the advanced configuration options accessible from the display panel keypad.

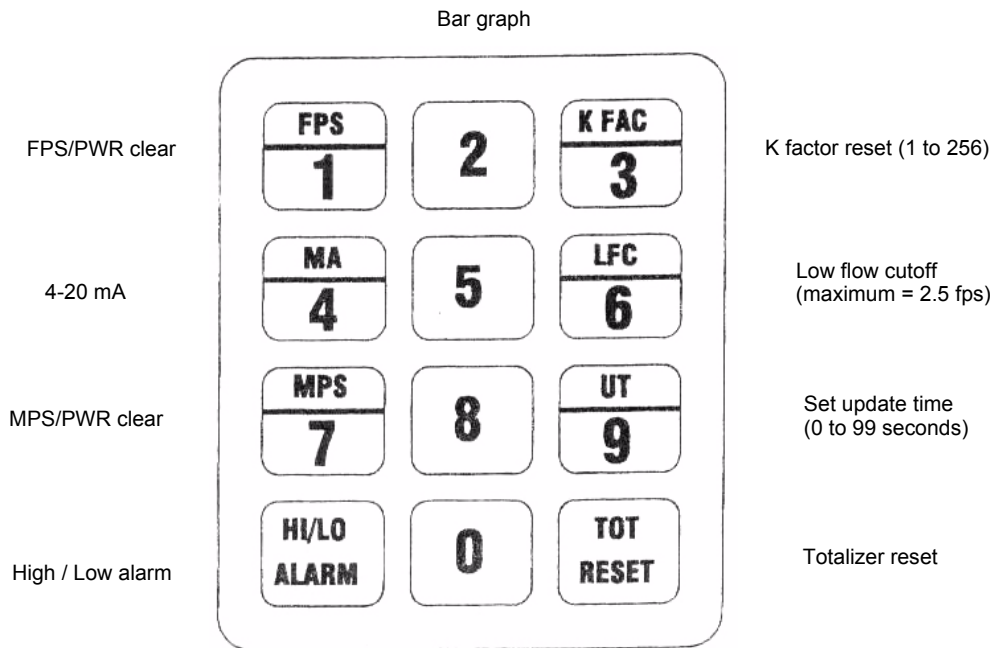

Figure 2-10. Display unit keypad

Table 2-6. Keyboard toggle menu ^{Note 1}

Key	Selection	Functional Specifications
1	FPS	Feet per second/ clear pwr
2	Bar graph	Analog bar graph of flow rate
3	K FAC	Select K factor while running
4	MA	Set up 4-20 mA analog output
6	LFC	Set low flow cut off (maximum = 2.5 fps)
7	MPS	Meters per second/ clear pwr
9	UT	Set update time (0 to 99 seconds)
	HI/LO ALARM	Set up HI/LO limit alarms
	TOT RESET	Reset totalizer while running
	^{Note 1} Press and hold key for one second to access/exit function	

BEFORE SETTING ADVANCED PARAMETERS

The default setting for secondary keyboard functions is feet per second (fps), or meters per second (mps) if the flow meter is configured for metric units. Once the flow meter is operational and you wish to activate the analog bar graph, 4-20 mA output, high or low alarm, or low flow cut-off options, you must first determine the velocity (fps or mps).

To determine the velocity unit of measure, push and hold the **FPS/1** or **MPS/7** key on the front panel of the electronics enclosure until the LCD screen changes and then release the key. The fps (or mps) value will display in the rate column of the display. With this information you may then push and hold the **FPS/1** or **MPS/7** key again and return the display to the normal volumetric indication.

Sample Parameter Setting

You have a velocity of 5 fps and you would like the 4-20 mA output to be 12 mA or 50% of scale. Push and hold the **MA/4** key until the screen changes and then release the key. Enter a scale value of 10 fps via the keypad. The screen will automatically return the display to volumetric indication. The 4-20 mA output will read 12 mA at the terminal strip located on the right side of the main electronics circuit board.

Note: Never adjust any of the potentiometers on the main processor board. These settings are to be performed by authorized personnel only.

SETTING ADVANCED PARAMETERS

This section explains how to set advanced parameters using the toggle keyboard on the front panel of the unit.

Bar Graph

To Set the Analog Bar Graph of Flow Rate:

1. Press the **FPS/1** or **MPS/7** key to obtain the current feet per second or meters per second reading. Press the key again to return to the flow reading parameters previously shown.
2. Press the **Graph/2** key. Enter the desired full-scale flow rate in feet per second or meters per second.
3. To return to the rate and totalizer flow reading, press the **Graph/2** key again.
4. To return to the graph, press the **Graph/2** key again.

K Factor (Correction Factor)

The default K Factor on the Doppler flow meter is set at 90 hZ/ fps for version V 5.6. For nearly all applications, this default K Factor setting should be adequate. There are only a few circumstances that might merit adjusting the default K Factor setting on your Doppler flow meter.

If the flow rate readings are not as expected, these are factors that may be contributing:

1. The meter is measuring flow with a high level of turbulence, which may be caused by too short of a straight run for proper transducer placement.
2. The liquid being measured has high viscosity, is too thick, or contains sound absorbing materials (for example, drilling mud).

If either of these conditions exist, and your flow readings appear inaccurate, then you may need to adjust the K Factor (correction factor) to get the desired flow rate.

Note: The K Factor is linear. Increase the K Factor to lower the flow rate or decrease the K Factor to increase the flow rate by the percentage that the flow is off.

Again, for most applications, the default K Factor setting ensures the most accurate reading by your Doppler flow meter. Consult [“Troubleshooting the Unit” on page 3-1](#) to troubleshoot inaccurate flow readings before making this adjustment.

To Set the K Factor:

1. Press the **K FAC/3** key.
2. Enter Hz/ FPS. If you want to keep the default setting, enter 090.
3. After setting the K Factor, the LCD screen will return to the rate and totalizer flow reading.

Analog Output

To Set the Analog Output:

1. Press the **FPS/1** or **MPS/7** key to obtain the current velocity reading in feet per second or meters per second. Press the key again to return to the flow reading parameters previously shown.
2. Press the **MA/4** key. Using the current **FPS/1** or **MPS/7** reading as a guide, enter the full scale feet per second or meters per second reading to set the output in mA.
3. After the output level has been set, the LCD screen will return to the rate and totalizer flow reading.

Low Flow Cutoff

To Set the Low Flow Cutoff:

1. Press the **FPS/1** or **MPS/7** key to obtain the current reading in feet per second or meters per second. Press the key again to return to the flow reading parameters previously shown.
2. Press the **LFC/6** key. Enter the cutoff in feet per second or meters per second. If you enter a parameter that is too high, the LCD screen will display the maximum allowable cutoff setting and then will return to the prompt for cutoff in feet per second.

3. After the low flow cutoff is set, the LCD screen will return to the rate and totalizer flow reading.

Meters per Second/ Power Clear

To Read Meters Per Second:

1. Press the **MPS/7** key. The LCD will show the flow reading in meters per second on the upper line of the LCD screen, replacing the rate parameter previously on the screen. The totalizer reading remains the same parameter.
2. To return to the previous flow rate reading, press the **MPS/7** key again.

Update Time

To Set Update Time:

1. Press the **UT/9** key.
2. Enter the update time in seconds. You may enter any number from 0-99.
3. After the update time is set, the LCD screen will return to the rate and totalizer flow reading.

Hi/Low Alarms

To Set the High/ Low Alarms:

1. Press the **FPS/1** or **MPS/7** key to obtain the current feet per second reading or meters per second reading. Press the key again to return to the flow reading parameters previously shown.
2. Press the **HI/LO ALARM** key. Enter the high limit alarm in feet per second or meters per second.
3. Now enter the low limit alarm in feet per second or meters per second.
4. After the high and low alarm parameters are set, the LCD screen will return to the rate and totalizer flow reading.

Totalizer Reset

To Reset the Totalizer While the Unit is Running:

1. Press the **TOT RESET** key. The totalizer reading will return to zero.
2. The meter will begin taking totalizer readings from zero. The rate reading remains unchanged.

Normal Operation

Once you have set up the Doppler flow meter for operation in your system, you may virtually forget about it. The system is maintenance free, and does not require calibration, since the readings do not drift over time. In the event of a power interruption, your settings will be saved for up to 10 days in volatile memory powered by a slow-discharge capacitor. the capacitor will recharge when power is restored.

Portable Battery Operation (Portable Units Only)

The LCD screen will flash **LOW BAT** every second when there is approximately one half hour of safe operation remaining. Never totally discharge the gel cell battery. The charger provided with the flow meter will recharge the battery fully in approximately 8 hours. You may leave the batteries in the charger overnight, since prolonged charging periods will not damage the battery. The **POWER** switch on the flow meter front panel must be in the **OFF** position in order for the internal battery to charge. If the internal battery has been deep discharged, it will be necessary to charge the battery for a minimum of 30 minutes before the front panel **POWER** switch is turned **ON**.

Troubleshooting and Customer Support

The following sections provide useful information for troubleshooting your Sono-Trak™ Doppler ultrasonic flow meter and process as related to your flow meter. Product warranty, return policy, and customer support information appears near the end of this chapter.

TROUBLESHOOTING THE UNIT

If you suspect your Doppler flow meter is malfunctioning, please perform the following checks before calling EMCO Flow Systems Support:

1. Make sure that the unit is properly connected to input power. See [“Mounting and Connecting Power to the Electronics Enclosure” on page 2-13](#). Also, see [“Status of Unit Power” on page 3-2](#).
2. Make sure that the transducers are properly connected to the electronics enclosure and that they are properly mounted. See [“Mounting and Connecting the Transducers” on page 2-9](#).
3. Ensure input power is on and power is within specifications. See [“Functional Specifications” on page 4-3](#) for power requirements.
4. Is the **Echo** LED light flashing or off? See [“Status of Echo LED: Flashing” on page 3-5](#) or [“Status of Echo LED: Off” on page 3-3](#) for troubleshooting information.
5. Does your Doppler flow meter flow rate reading appear too low, too high, or erratic, but your **Echo** light is on? See [“Status of Flow Reading: High or Low” on page 3-6](#) or [“Status of Flow Reading: Erratic” on page 3-8](#) for troubleshooting information. Also, consult [“Echo LED Light Considerations” on page 3-9](#) for more information about the **Echo** light.
6. Have you performed the above checks and you still have no flow reading?
 - ▶ If you have performed all the above checks and followed troubleshooting procedures in the [“Flow Meter Troubleshooting Tables” on page 3-2](#) and your unit is still malfunctioning, contact [“EMCO Flow Systems Support” on page 3-11](#).

Flow Meter Troubleshooting Tables

Follow these tables in sequential order for the best use. Answer the heading question in bold at the beginning of each section before continuing on to the next section.

STATUS OF UNIT POWER

Is the unit receiving power? (Is the green Power light on?)

- ▶ Yes. If the unit is receiving power, continue on to [“Status of Echo LED: Off” on page 3-3](#).
- ▶ No. If the unit is not receiving power, troubleshoot using [Table 3-1](#) below.

Table 3-1. Status of unit power troubleshooting checklist

Question/ Possible Cause	Corrective Action
Is AC or BATTERY (DC) power properly connected to the processor board?	Ensure that input power is properly connected. See “To Connect Input Power to the Electronics Enclosure:” on page 2-13 .
Is the battery charged if you are using BATTERY (DC) power, or is the AC power cord plugged in if you are using AC power?	If you are using DC battery power, make sure your battery is charged and that the power cables are securely connected. If you are using AC power, make sure your AC power is plugged in. See “To Connect Input Power to the Electronics Enclosure:” on page 2-13 and “Portable Battery Operation (Portable Units Only)” on page 2-25 for more information.
Is the power switch on the display panel on?	Ensure the power switch on the front display panel is in the On position. See “Display panel” on page 2-16 for the location of this switch.
Is the A/C Select voltage selector set correctly?	Make sure that the A/C Select switch is in the proper location for your system input power (115 VAC or 230 VAC). See “To Connect Input Power to the Electronics Enclosure:” on page 2-13 and Figure 2-8 on page 2-14 for the location of the switch.

Table 3-1. Status of unit power troubleshooting checklist

Question/ Possible Cause	Corrective Action
Is the AC/ BATTERY power switch set correctly?	<p>Make sure the AC/ BATTERY switch is in the proper position for your system input power:</p> <ul style="list-style-type: none"> • AC = AC input power • BATTERY = DC input (battery) power <p>See “To Connect Input Power to the Electronics Enclosure:” on page 2-13 and Figure 2-8 on page 2-14 for the location of the switch.</p>
Is there a LOW BAT flashing in the display?	<p>If you are switching from BATTERY (DC) power to AC power and the A/C Select switch selection does not match your incoming power, you may see a LOW BAT warning in the front panel display. Adjust the A/C Select switch to the correct incoming power level (115 VAC or 230 VAC) and this warning should disappear.</p> <p>If you are using the battery (DC power) to power the unit, your battery may be low. See “Portable Battery Operation (Portable Units Only)” on page 2-25.</p>
Is there is a blown input power fuse?	<p>Check to see if all fuses on the processor board are good.</p> <p>See Figure 2-8 on page 2-14 for fuse block location on the processor board.</p>

STATUS OF ECHO LED: OFF

Is the Echo LED on steady?

- ▶ Yes. If the **Echo** LED is on steady or is flashing, continue on to [“Status of Echo LED: Flashing”](#) on page 3-5.
- ▶ No. If the **Echo** LED is off, troubleshoot using [Table 3-2](#) below.

Note: See [“Additional Troubleshooting Information”](#) on page 3-9 for additional information about the Echo LED indicator.

Table 3-2. Status of Echo light troubleshooting checklist: Echo off

Question/ Possible Cause	Corrective Action
Are the transducers properly connected to the processor board?	<p>Make sure the transducer wires are connected correctly to the processor board.</p> <p>See “To Connect the Transducers to the Electronics Enclosure:” on page 2-11.</p>
Are the transducers mounted properly on the pipe?	<p>Make sure that the transducers have been mounted on a clean, smooth pipe using the required coupling grease. Ensure that the transducers are securely mounted flush with the pipe, side by side.</p> <p>See “To Mount the Clamp-On Transducers to the Pipe:” on page 2-9.</p>
Is there fluid in the pipe? Is the pipe full?	<p>Verify that the pipe is full of fluid and that the fluid is flowing above the minimum velocity specifications.</p> <p>See “Functional Specifications” on page 4-3 for flow velocity specifications.</p>
Have the transducers been placed in the recommended location on the pipe?	<p>Make sure that the transducers have been mounted in an acceptable location:</p> <ul style="list-style-type: none"> ▶ Consider straight run requirements (see “Straight Run Requirements” on page 2-5 for more information ▶ Make sure the transducers are mounted flush with the pipe, facing the same direction <p>See “To Mount the Clamp-On Transducers to the Pipe:” on page 2-9 for more details.</p>

Table 3-2. Status of Echo light troubleshooting checklist: Echo off

Question/ Possible Cause	Corrective Action
Has the pipe been cleaned down to bare metal before transducer placement? Is this an old pipe?	<p>Make sure the pipe was cleaned with sandpaper prior to transducer placement. Also, check to make sure the type of pipe in your application is suitable for use with a Doppler flow meter.</p> <p>See “Assessing Pipe Material and Condition” on page 2-5.</p>
Is the measured fluid too clean, or is the particle content fluctuating below readable specifications?	<p>Verify that suspended solid content of fluid is at least 40 microns @ 35 ppm with at least a 0.2% density difference from the liquid.</p> <p>See “Suspended Particle Test For Doppler Signals” on page 3-10 to check your fluid for particle content, and also consult “Determining if Your Process/Installation is Right for a Doppler Flow Meter” on page 2-3.</p> <p><i>Note:</i> Use a transit time meter if the fluid does not meet the suspended solid specifications of a Doppler flow meter. Contact “EMCO Flow Systems Support” on page 3-11 for more information.</p>

STATUS OF ECHO LED: FLASHING

Is the Echo LED flashing?

- ▶ No. If the **Echo** LED light is on steady, continue on to [“Status of Flow Reading: High or Low”](#) on page 3-6.
- ▶ Yes. If the **Echo** LED light is flashing, troubleshoot using [Table 3-3](#) below.

Note: Review the three questions in [Table 3-3](#). If you can answer yes to all three, and you have determined that you do not have a power issue, you may have an application that would be better suited for a transit time meter. See [“Determining if Your Process/Installation is Right for a Doppler Flow Meter”](#) on page 2-3 and [“Additional Troubleshooting Information”](#) on page 3-9.

Table 3-3. Status of Echo light troubleshooting checklist: Echo flashing

Question/ Possible Cause	Corrective Action
Have the transducers been placed in the recommended location on the pipe?	<p>Make sure that the transducers have been mounted in an acceptable location:</p> <ul style="list-style-type: none"> ▶ Try moving the transducers. Consider straight run requirements when deciding where they need to be mounted (see “Straight Run Requirements” on page 2-5 for more information) ▶ Make sure the transducers are mounted side by side, flush with the pipe ▶ Make sure the exterior of the pipe was cleaned prior to mounting the transducers <p>See “To Mount the Clamp-On Transducers to the Pipe:” on page 2-9 for more details.</p>
Have you performed the suspended particle test to see if the liquid in the flow is compatible with Doppler operation?	See “Suspended Particle Test For Doppler Signals” on page 3-10.
Have you consulted the Echo light consideration section?	See “Echo LED Light Considerations” on page 3-9 for information on whether the Doppler is the right meter for your application. A transit time meter may work better for your application if the Echo light continues flashing.

STATUS OF FLOW READING: HIGH OR LOW

Is the flow reading showing a rate that is lower or higher than expected?

- ▶ No. If the flow reading is erratic rather than low or high, or you are experiencing another issue, continue on to [“Status of Flow Reading: Erratic”](#) on page 3-8.
- ▶ Yes. If the flow reading appears too low or too high, troubleshoot using [Table 3-4](#) below.

Table 3-4. Status of flow reading troubleshooting checklist: High or low

Question/ Possible Cause	Corrective Action
Has the meter been properly programmed?	<p>Using the display panel keypad and the LCD screen, verify that the rate selection and totalizer selection are set correctly.</p> <p>See “To Operate Your Doppler Flow Meter for the First Time:” on page 2-18.</p>
Has the meter been set up with sufficient straight run piping?	<p>Make sure that the transducers are properly placed for use with your Doppler flow meter.</p> <p>See “Straight Run Requirements” on page 2-5 for more information on correct transducer placement in your system.</p>
Are the transducers mounted properly on the pipe?	<p>Make sure that the transducers have been mounted on a clean, smooth pipe using the required coupling grease. Ensure that the transducers are securely mounted side by side.</p> <p>See “To Mount the Clamp-On Transducers to the Pipe:” on page 2-9.</p>
Has the pipe been cleaned down to bare metal before transducer placement? Is this an old pipe?	<p>Make sure the pipe was cleaned with sandpaper prior to transducer placement. Also, check to make sure the type of pipe in your application is suitable for use with a Doppler flow meter.</p> <p>See “Assessing Pipe Material and Condition” on page 2-5.</p>
Does your Doppler show a flow reading that varies from the reading on your alternative measurement device?	<p>Verify that pumps are operating and that valve settings are correct. Compare the velocity reading with an alternative type of flow meter.</p> <ul style="list-style-type: none"> ▶ If the flow reading on your Doppler is similar to the reading on your alternative meter, the Doppler is probably reading correctly. ▶ If the flow reading on your Doppler varies from the reading on the alternative meter, you may need to adjust the K Factor accordingly to correct the flow reading. <p>See “K Factor (Correction Factor)” on page 2-22 for information on adjusting your K Factor.</p>

STATUS OF FLOW READING: ERRATIC

Is the flow reading showing an erratic rate?

- ▶ Yes. If the flow reading appears erratic, troubleshoot using [Table 3-5](#) below.
- ▶ No. If you have followed all the troubleshooting steps and procedures and your Doppler is still not working correctly, contact [“EMCO Flow Systems Support” on page 3-11](#) for information on how to proceed.

Table 3-5. Status of flow reading troubleshooting checklist: Erratic

Question/ Possible Cause	Corrective Action
Have the transducers been placed in the recommended location on the pipe?	<p>Make sure that the transducers have been mounted in an acceptable location:</p> <ul style="list-style-type: none"> ▶ Consider straight run requirements (see “Straight Run Requirements” on page 2-5 for more information ▶ Make sure the transducers are mounted side by side <p>See “To Mount the Clamp-On Transducers to the Pipe:” on page 2-9 for more details.</p>
Has the pipe been cleaned down to bare metal before transducer placement? Is this an old pipe?	<p>Make sure the pipe was cleaned with sandpaper prior to transducer placement. Also, check to make sure the type of pipe in your application is suitable for use with a Doppler flow meter.</p> <p>See “Assessing Pipe Material and Condition” on page 2-5.</p>
Is the unit near an electric motor or motor controller?	<p>Move the transducers away from interference and see if the flow readings become more stable.</p>
Is your update time allowing for erratic flow readings?	<p>Change your flow meter update time and see if the flow readings become more stable.</p> <p>See “To Set Update Time:” on page 2-24.</p>
Can you adjust Analog damping to provide a more accurate reading?	<p>See “Main electronics board connections” on page 2-12 and “Another view of processor board connections” on page 2-14 to find the Analog damping on the Doppler flow meter processor board and adjust it to eliminate erratic flow readings.</p>

Additional Troubleshooting Information

ECHO LED LIGHT CONSIDERATIONS

Sono-Trak™ Doppler ultrasonic flow meters require suspended solids or air bubbles to operate. The strict requirement is that sonic discontinuities exist. If the speed of sound in the solids and liquids are identical, then there are no sonic discontinuities (which act as ultrasonic reflectors), and most Doppler flow meters will not function. Some bacterial slurries and chemical slurries may have suspended solids but cannot be measured with a Doppler flow meter for this reason.

The behavior of the **Echo** light on the display panel of your Doppler flow meter electronics enclosure may provide indication as to whether the Doppler flow meter is the correct one for your application. If after troubleshooting your unit, the **Echo** light does not remain on steady while you are operating your unit, you may need to consider changing the meter to a transit time meter.

See [“Determining if Your Process/Installation is Right for a Doppler Flow Meter”](#) on page 2-3 and [“Troubleshooting the Unit”](#) on page 3-1 if you are having trouble maintaining a steady **Echo** light during operation of your flow meter.

Table 3-6. Echo light scenarios

Echo light condition	Flow rate reading	Applicable Meter	Solution
Illuminated steady	Yes	Doppler flow meter	If the Echo light is on and the flow reading appears correct, the Doppler is the best meter for your application.
Flashing	Yes	Doppler flow meter or Transit time meter	There may be an inadequate level of reflective materials in the flow to ensure correct flow readings. Move the transducers until you get a steady light, or replace your Doppler meter with a transit time meter.
Off	Yes	Transit time meter	There may be an inadequate level of reflective materials in the flow to ensure correct flow readings. Replace your Doppler meter with a transit time meter.
Off	No flow	Contact Factory	Clamp on transducers may not be able to provide accurate flow readings in your application.

SUSPENDED PARTICLE TEST FOR DOPPLER SIGNALS

Particles in a liquid may be either in suspension or dissolved. Dissolved particles will not reflect Doppler signals because there is no physical dimension nor density difference to return the sound to the receiver.

Suspended particles generally will return the Doppler signal if there are enough present and their size is sufficient to meet the requirements of the transmitted frequency. Materials such as wood pulp, algae, moss, onion skins, fine sand, or other materials that do not meet the 35 ppm/ 40 micron/ 0.2% density difference minimum requirements will not reflect sounds. Instead, the signal simply passes through this material as if it were water. Usually these materials have a specific gravity of 0.999 or 1.001. This is almost exactly the same as water itself and therefore will neither rise nor fall in the solution. These materials will move about almost anywhere in the solution controlled only by the motion of the liquid itself.

A simple test requires a clear glass container and a sample of the liquid you wish to measure with the Doppler sensors. Stir the liquid and watch it for about 3 to 5 minutes. If the visible particles in suspension neither rise nor fall, they are most likely the same specific gravity as water and may not reflect Doppler signals. If these particles are the same specific gravity as water, but do have a membrane or shell around them that is at least 0.2% density difference than the water molecules, then the signals should be strong enough for the Doppler to report correct flow readings.

If the particles rise or fall in the solution, they should provide adequate sonic reflection as long as they meet the specified quantity, size, and density requirements for the Doppler (see [“Specifications and Reference Information”](#) on page 4-1 for more information).

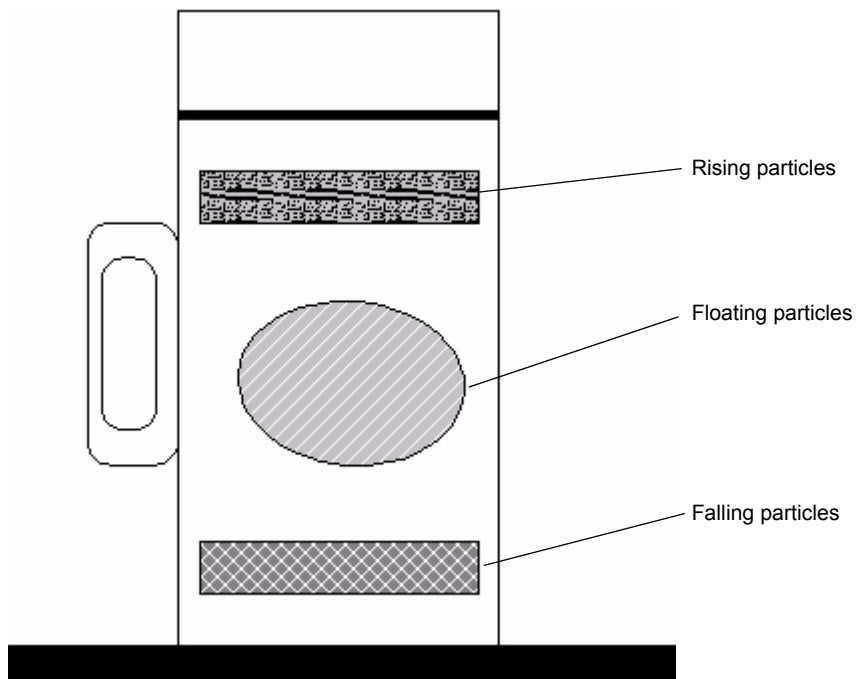

Figure 3-1. *Suspended particle test*

EMCO FLOW SYSTEMS SUPPORT

For product support or more information on EMCO Industrial Flow Products, contact:

EMCO Sales

Advanced Energy
1625 Sharp Point Drive
Fort Collins, CO 80525 USA

Phone: 800-356-9362 or
970-407-6949

Fax: 970-407-5179

Email: support@emcoflow.com
www.emcoflow.com

The complete EMCO product line for liquid, gas, and steam applications includes industrial inline vortex, industrial insertion vortex and turbine, commercial vortex, electromagnetic, and clamp-on ultrasonic flow products. For more information, refer to the EMCO website (<http://www.emcoflow.com/>).

RETURNING UNITS FOR REPAIR

Before returning any product for repair and/or adjustment, ***first follow all troubleshooting procedures***. If, after following these procedures, you still have a problem, or if the procedure instructs you to, contact EMCO Flow Systems and discuss the problem with a representative. (See also [“Authorized Returns” on page 3-13](#)).



WARNING:

All returns to EMCO Flow Systems Support at Advanced Energy must be free of harmful, corrosive, radioactive, or toxic materials, and have purge documentation when appropriate.

If you return a unit without first getting authorization from EMCO Flow Systems Support and that unit is found to be functional, you will be charged a retest and calibration fee, plus shipping charges.

To ensure years of dependable service, Advanced Energy® products are thoroughly tested and designed to be among the most reliable and highest quality systems available worldwide.

WARRANTY

Advanced Energy® (AE) products are warranted to be free from failures due to defects in material and workmanship for 12 months after they are shipped from the factory (please see warranty statement below, for details).

In order to claim shipping or handling damage, you must inspect the delivered goods and report such damage to AE within 30 days of your receipt of the goods. Please note that failing to report any damage within this period is the same as acknowledging that the goods were received undamaged.

For a warranty claim to be valid, it must:

- Be made within the applicable warranty period
- Include the product serial number and a full description of the circumstances giving rise to the claim
- Have been assigned a return material authorization number (see below) by EMCO Flow Systems Support at Advanced Energy

All warranty work will be performed at an authorized AE service center (see list of contacts at the beginning of this chapter). You are responsible for obtaining authorization (see details below) to return any defective units, prepaying the freight

costs, and ensuring that the units are returned to an authorized AE service center. AE will return the repaired unit (freight prepaid) to you by second-day air shipment (or ground carrier for local returns); repair parts and labor will be provided free of charge. Whoever ships the unit (either you or AE) is responsible for properly packaging and adequately insuring the unit.

Authorized Returns

Before returning any product for repair and/or adjustment, call EMCO Flow Systems Support and discuss the problem with them. Be prepared to provide the model number and serial number of the unit as well as the reason for the proposed return. This consultation call will allow EMCO Flow System Support to determine if the unit must actually be returned for the problem to be corrected. Such technical consultation is always available at no charge.

Units that are returned without authorization from EMCO Flow Systems Support and that are found to be functional will not be covered under the warranty (see warranty statement, below). That is, you will have to pay a retest and calibration fee, and all shipping charges.

Warranty Statement

The seller makes no express or implied warranty that the goods are merchantable or fit for any particular purpose except as specifically stated in printed AE specifications. The sole responsibility of the Seller shall be that it will manufacture the goods in accordance with its published specifications and that the goods will be free from defects in material and workmanship. The seller's liability for breach of an expressed warranty shall exist only if the goods are installed, started in operation, and tested in conformity with the seller's published instructions. The seller expressly excludes any warranty whatsoever concerning goods that have been subject to misuse, negligence, or accident, or that have been altered or repaired by anyone other than the seller or the seller's duly authorized agent. This warranty is expressly made in lieu of any and all other warranties, express or implied, unless otherwise agreed to in writing. The warranty period is 12 months after the date the goods are shipped from AE. In all cases, the seller has sole responsibility for determining the cause and nature of the failure, and the seller's determination with regard thereto shall be final.

Specifications and Reference Information

The following sections provide specification and accessory information for the Sono-Trak™ Doppler ultrasonic flow meter, as well as useful pipe and conversion information.

PERFORMANCE SPECIFICATIONS

Table 4-1. Performance specifications

Description	Specification
Fluid conditions	
Measured fluid	Homogenous liquids with Newtonian flow profiles (sludges, slurries, sewage, wastewater, and other fluids containing suspended particles)
State of flow	Axis-symmetric flow in pipe filled with fluid
Fluid type	Liquids containing suspended particles of at least 35 ppm at 40 microns at 0.2% density of undissolved solids or air bubbles
Measurable fluid temperature range	-40 °F to 300 °F (-40 °C to 149 °C)
Velocity range	0.1 fps to 50 fps (0.04 mps to 15.25 mps)
Flow sensitivity	0.01 fps (0.04 mps)
Piping conditions	
Pipe diameter range	Velocity indication: 0.5" to 300" (13 mm to 7620 mm) diameter Volumetric indication: 0.5" to 100" (13 mm to 2540 mm) diameter
Pipe	Including but not limited to: carbon steel, stainless steel, ductile iron, cast iron, FRP, PVC, fiberglass, teflon, and most concrete lined or coated pipes
Pipe lining	Including but not limited to: tar, epoxy, mortar, rubber, teflon, PVC, and glass

Table 4-1. Performance specifications (Continued)

Description	Specification
Measurement Accuracy	
Accuracy	Typically $\pm 1\%$ to 3% of full scale See Table 2-2 on page 2-6 for straight run requirements and specific accuracies. <i>Note:</i> Accuracy is a function of flow profile.
Linearity	$\pm 0.5\%$ of full scale
Repeatability	$\pm 0.1\%$ of full scale
Response time	1 second or less

PHYSICAL SPECIFICATIONS

Table 4-2. Physical specifications

Description	Specification
Electronics Enclosure	
Dimensions	9.21" (H) x 7.21" (W) x 5.09" (D) 285 mm (H) x 183 mm (W) x 129 mm (D) <i>Note:</i> See Figure 4-1 on page 4-6 for dimensional illustrations.
Weight	12 lb (5.45 kg)
Materials	Flame retardant, fiberglass reinforced polyester with lockable latch, gray in color
Environmental rating	NEMA 4X (IP65)
Ambient temperature range	-13 °F to 132 °F (-25 °C to 55 °C)
Ambient humidity	Less than 100% RH
Transducers	
Dimensions	<ul style="list-style-type: none"> • Transducer heads: 4.85"(L) x 1.33"(W) x 1.35"(D) (123 mm x 33.8 mm x 34.3 mm) • Digitizer: 4.45"(L) x 2.50" (W) x 1.10" (D) (113 mm x 63.5 mm x 28 mm) <i>Note:</i> See Figure 4-3 on page 4-8 for the dimensional illustration
Weight	2.30 lb (1 kg)

Table 4-2. Physical specifications (Continued)

Description	Specification
Housing material	Cast aluminum
Mounting	Mounted to the outside of pipe by means of stainless straps, nylon belts, or bungee and steel chain
Crystal wedge material	Epoxy resin (all transducer models)
Environmental rating	NEMA 6 (IP67)
Ambient temperature range	-20 °F to 200 °F (-29 °C to 93 °C)
Ambient humidity	Less than 100% RH
Transducer cable	
Standard cable	25' (7.6 m) 2 twisted pairs, 24 AWG, belfoil shield <i>Note:</i> Custom cable lengths are available
Maximum cable length	5000' (1524 m)

FUNCTIONAL SPECIFICATIONS

Table 4-3. Functional specifications

Description	Specification
Power	
Fixed units	110 VAC or 220 VAC at 50/60 Hz (AC line voltage selectable via internal selector switch; see Figure 2-8 on page 2-14 for switch location) 12 VDC (DC operation enabled by internal selector switch; see Figure 2-8 on page 2-14 for switch location)
Portable units	Internal gel-cell, 8-hour continuous operation built-in battery Recharge time is 12 hours using the external power adaptor/charger or DC auto cigarette lighter
Power adaptor/charger	Standard adaptor: 115 VAC, 50/60 Hz ($\pm 10\%$) input delivering 12 VDC, 500 mA output Optional adaptor: 230 VAC, 50/60 Hz ($\pm 10\%$) input delivering 12 VDC, 500 mA output
Power consumption	10 W typical
Analog output signal	4 mA to 20 mA DC, 700 Ω maximum load resistance, internally fused, active output

Table 4-3. Functional specifications (Continued)

Description	Specification
Alarm output	When on AC power: 15.0 VDC = Active alarm <ul style="list-style-type: none"> • High alarm: switched +15.0 VDC, 500 mA • Low alarm: switched +15.0 VDC, 500 mA When on battery power: 12.0 VDC = Active alarm <ul style="list-style-type: none"> • High alarm: switched + 12.0 VDC, 500 mA • Low alarm: switched + 12.0 VDC, 500 mA
Power failure backup	An internal <i>super-capacitor</i> allows the electronics assembly to retain all parameter information and current totalizer value for up to 10 days
Standard interface	
LCD display	2-line, 16 characters per line, high resolution
LED indicators	<ul style="list-style-type: none"> • Yellow: Echo signal received • Red: High alarm or low alarm activated • Green: Power available
Keypad	12 keys, tactile feedback <i>Note:</i> Keypad lockout available through internal switch; see “To Save Your Programmed Flow Reading Settings Using the Security Switch:” on page 2-19 and Figure 2-8 on page 2-14 for the switch location
Display panel	Rate selection, totalizer selection, <i>K</i> factor selection, analog output set, low flow cutoff set, update time (damping) set, high/low alarm set, fps or mps selection, totalizer reset
Output setting function	4-20 mA output scaling (set in velocity from keypad)
Alarm setting function	High and low alarm set points (entered in velocity from keypad)
Rate indication	4-digit LCD, velocity or volume (user selectable) English units: feet per second (fps), gallons per minute (gpm), cubic feet per second, and million gallons per day Metric units: meters per second (mps), liters per second (lps), and cubic meters per second <i>Note:</i> Gallons refers to U.S. gallons.

Table 4-3. Functional specifications (Continued)

Description	Specification
Totalizer indication	11-digit LCD English units: gallons, cubic feet, acre feet, and millions of gallons Metric units: liters and cubic meters <i>Note: Gallons refers to U.S. gallons.</i>
Update time (damping)	0 s to 99 s, entered from keypad
Low flow cutoff	0 fps to 2.5 fps (0 mps to 0.76 mps), entered from keypad
K factor	A value of 1 to 256, entered from the keypad depending upon sensor type. The default is 90 Hz (correction factor) for version V 5.6.
Totalizer reset	Totalizer can be manually reset to zero from the keypad

DIMENSIONAL DRAWINGS

Electronics Enclosure Dimensions

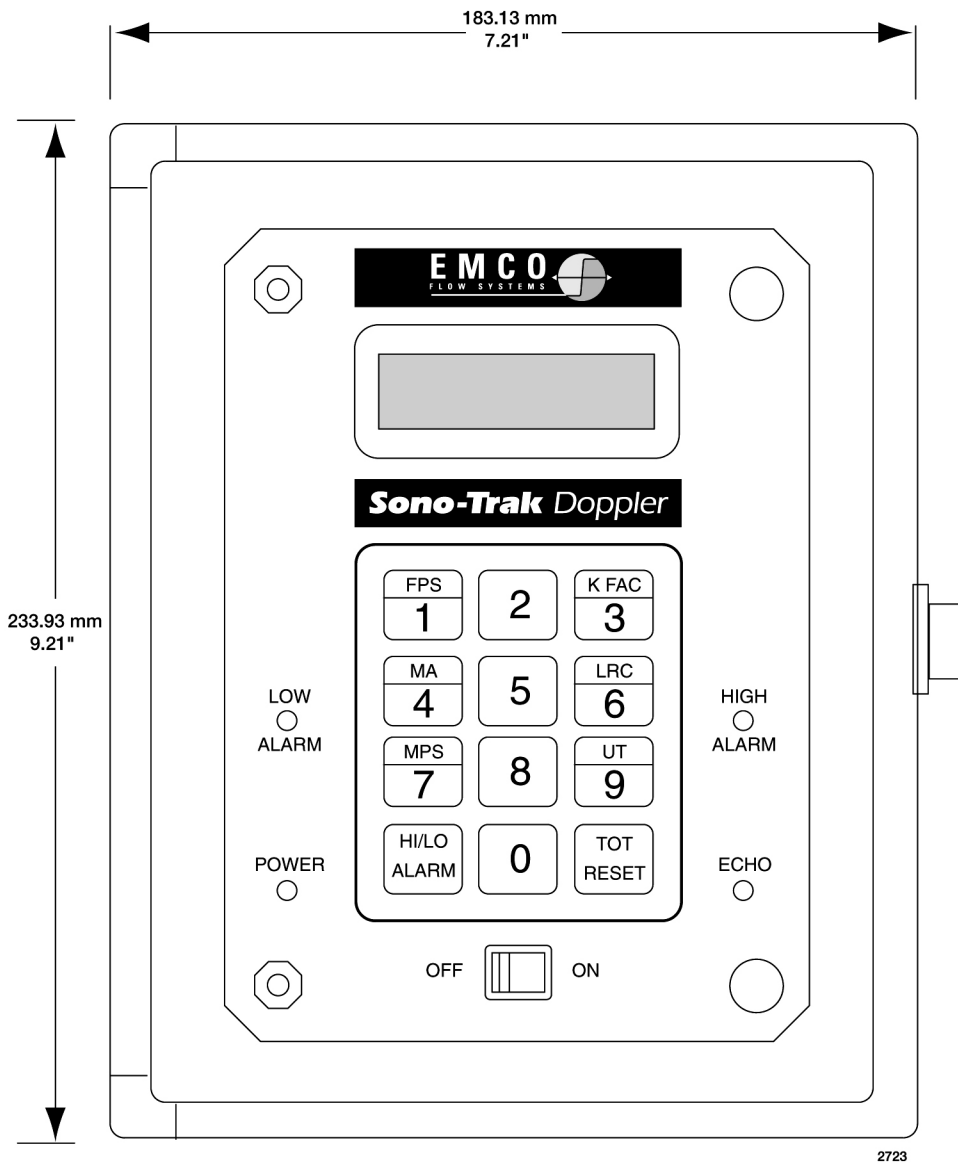

Figure 4-1. Front view of the electronics enclosure (the display panel)

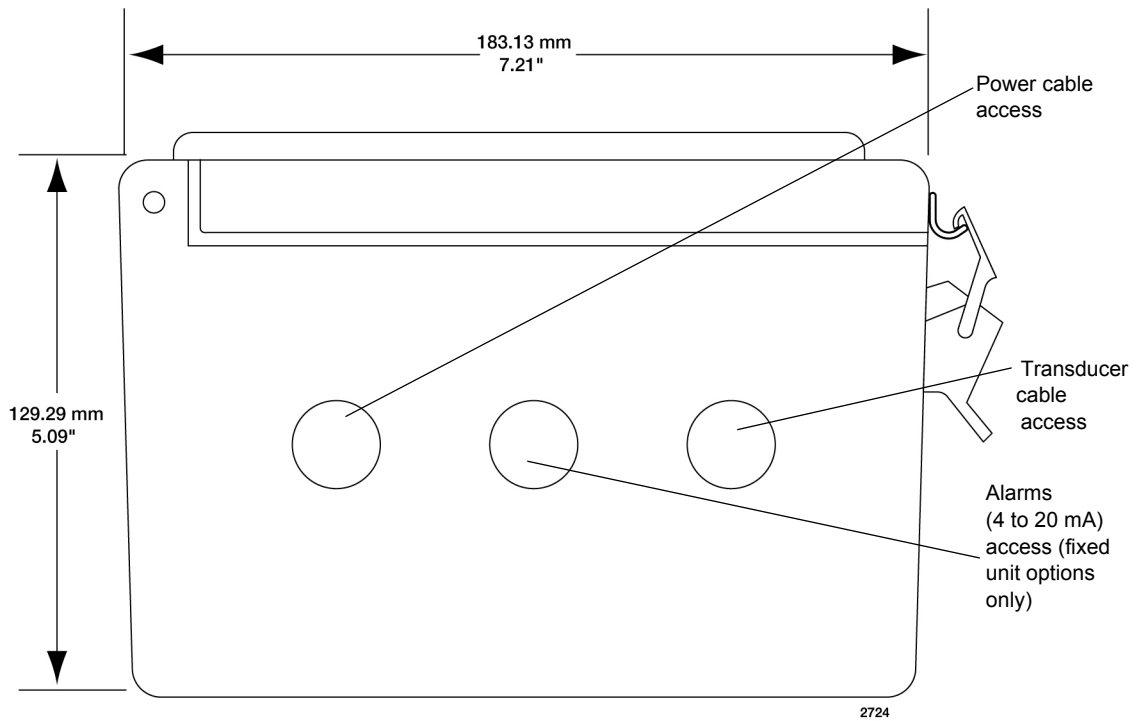

Figure 4-2. Bottom view of the electronics enclosure

Clamp-On Transducer and Digitizer Dimensions

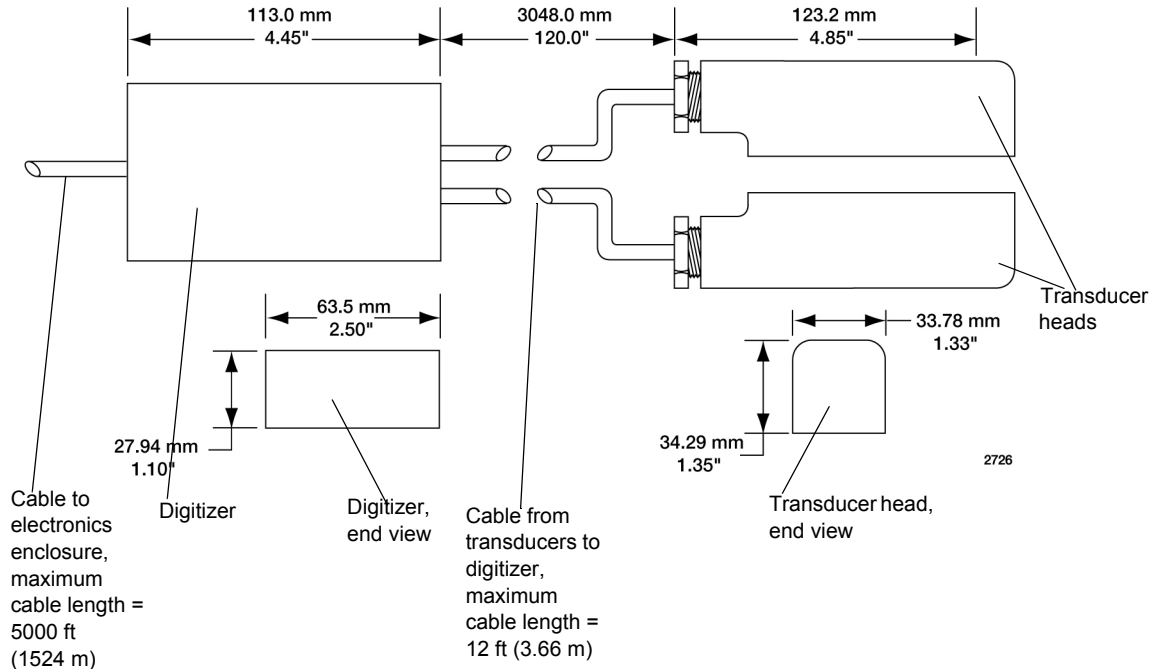

Figure 4-3. Dimensions of clamp-on transducer

REFERENCE INFORMATION

This section provides reference information for setting up the Doppler flow meter in your system.

- [“Standard Pipe Data”](#) on page 4-9 contains three tables to assist in pipe measurement:
 - ▶ [“Steel, stainless steel, and PVC”](#) on page 4-9
 - ▶ [“Cast iron pipe \(standard classes\)”](#) on page 4-10
 - ▶ [“Ductile iron pipe standard classes \(inside diameters\)”](#) on page 4-11
- [“Velocity Conversion Tables”](#) on page 4-12 contains three tables to assist in converting the default flow readings of meters per second or feet per second:
 - ▶ [“Velocity conversion table \(MPS to LPM and LPS\)”](#) on page 4-12
 - ▶ [“Velocity conversion table \(MPS to LPS and M3/Hr\)”](#) on page 4-12
 - ▶ [“Velocity conversion table \(FPS to GPM\)”](#) on page 4-13

Standard Pipe Data

Table 4-4. Steel, stainless steel, and PVC

Size Inches	Standard Schedules Inside Diameters													
	5	10 LTWALL	20	30	STD	40	60	STG	80	100	120	140	180	O.D.
1	1.185	1.097			1.049	1.049		0.957	0.957				0.815	1.315
1.25	1.53	1.442			1.380	1.380		1.278	1.278				1.160	1.660
1.5	1.77	1.682			1.610	1.610		1.500	1.500				1.338	1.900
2	2.245	2.157			2.067	2.067		1.939	1.939				1.687	2.375
2.5	2.709	2.635			2.469	2.469		2.323	2.323				2.125	2.875
3	3.334	3.260			3.068	3.068		2.900	2.900				2.624	3.500
3.5	3.834	3.760			3.548	3.548		3.364	3.364					4.000
4	4.334	4.260			4.026	4.026		3.826	3.826		3.624		3.438	4.500
5	5.345	5.295			5.047	5.047		4.813	4.813		4.563		4.313	5.563
6	6.407	6.357			6.065	6.065		5.761	5.761		5.501		5.187	6.625
8	8.407	8.329	8.125	8.071	7.981	7.981	7.813	7.625	7.625	7.437	7.187	7.001	6.813	8.625
10	10.482	10.42	10.25	10.13	10.02	10.02	9.750	9.750	9.562	9.312	9.062	8.750	8.500	10.75
12	12.42	12.39	12.25	12.09	12.00	11.938	11.626	11.75	11.37	11.06	10.75	10.50	10.12	12.75
14		13.50	13.37	13.25	13.25	13.124	12.814	13.00	12.50	12.31	11.81	11.50	11.18	14.00
16		15.50	15.37	15.25	15.25	15.000	14.688	15.00	14.31	13.93	13.56	13.12	12.81	16.00
18		17.50	17.37	17.12	17.25	16.876	16.564	17.00	16.12	15.68	15.25	14.87	14.43	18.00
20		19.50	19.25	19.25	19.25	18.814	18.376	19.00	17.93	17.43	17.00	16.50	16.06	20.00
24		23.50	23.25	23.25	23.25	22.626	22.126	23.00	21.56	20.93	20.93	19.87	19.31	24.00
30		29.37	29.00	29.00	29.25	29.250		29.00						30.00
36		35.37	35.00	35.00	35.25	35.25		35.00						36.00
42					41.25	41.25		41.00						42.00
48					47.25	47.25		47.00						48.00

Table 4-5. Cast iron pipe (standard classes)

Nominal Pipe Size Inches	Class A		Class B		Class C		Class D		Class E		Class F		Class G		Class H	
	O.D.	I.D.	O.D.	I.D.	O.D.	I.D.	O.D.	I.D.	O.D.	I.D.	O.D.	I.D.	O.D.	I.D.	O.D.	I.D.
3	3.80	3.02	3.96	3.12	3.96	3.06	3.96	3.00								
4	4.80	3.96	5.00	4.10	5.00	4.04	5.00	3.96								
6	6.90	6.02	7.10	6.14	7.10	6.08	7.10	6.00	7.22	6.06	7.22	6.00	7.38	6.08	7.38	6.00
8	9.05	8.13	9.05	8.03	9.30	8.18	9.30	8.10	9.42	8.10	9.42	8.10	9.60	8.10	9.60	8.00
10	11.10	10.10	11.10	9.96	11.40	10.16	11.40	10.04	11.60	10.12	11.60	10.00	11.84	10.12	11.84	10.00
12	13.20	12.12	13.20	11.96	13.50	12.14	13.50	12.00	13.78	12.14	13.78	12.00	14.08	12.14	14.08	12.00
14	15.30	14.16	15.30	13.98	15.65	14.17	15.65	14.01	15.98	14.18	15.98	14.00	16.32	14.18	16.32	14.00
16	17.40	16.20	17.40	16.00	17.80	16.20	17.80	16.02	18.16	16.20	18.16	16.00	18.54	16.18	18.54	16.00
18	19.50	18.22	19.50	18.00	19.92	18.18	19.92	18.00	20.34	18.20	20.34	18.00	20.78	18.22	20.78	18.00
20	21.60	20.26	21.60	20.00	22.06	20.22	22.06	20.00	22.54	20.24	22.54	20.00	23.02	20.24	23.02	20.00
24	25.80	24.28	25.80	24.02	26.32	24.22	26.32	24.00	26.90	24.28	26.90	24.00	27.76	24.26	27.76	24.00
30	31.74	29.98	32.00	29.94	32.40	30.00	32.74	30.00	33.10	30.00	33.46	30.00				
36	37.96	35.98	38.30	36.00	38.70	35.98	39.16	36.00	39.60	36.00	40.04	36.00				
42	44.20	42.00	44.50	41.94	45.10	42.02	45.58	42.02								
48	50.50	47.98	50.80	47.96	51.40	47.98	51.98	48.00								
54	56.66	53.96	57.10	54.00	57.80	54.00	58.40	53.94								
60	62.80	60.02	63.40	60.06	64.20	60.20	64.82	60.06								
72	75.34	72.10	76.00	72.10	76.88	72.10										
84																

Table 4-6. Ductile iron pipe standard classes (inside diameters)

Size Inches	Outside Diameter	Class 50	Class 51	Class 52	Class 53	Class 54	Class 55	Class 56	Cement Lining ^{Note 1}	
									Standard Thickness	Double Thickness
3	3.96		3.46	3.40	3.34	3.28	3.22	3.16	0.125	0.250
4	4.80		4.28	4.22	4.16	4.10	4.04	3.98		
6	6.90	6.40	6.34	6.28	6.22	6.16	6.10	6.04		
8	9.05	8.51	8.45	8.39	8.33	8.27	8.21	8.15		
10	11.10	10.52	10.46	10.40	10.34	10.28	10.22	10.16		
12	13.20	12.58	12.52	12.46	12.40	12.34	12.28	12.22		
14	15.30	14.64	14.58	14.52	14.46	14.40	14.34	14.28	0.1875	0.375
16	17.40	16.72	16.66	16.60	16.54	16.48	16.42	16.36		
18	19.50	18.80	18.74	18.68	18.62	18.56	18.50	18.44		
20	21.60	20.88	20.82	20.76	20.70	20.64	20.58	20.52		
24	25.80	25.04	24.98	24.92	24.86	24.80	24.74	24.68		
30	32.00	31.22	31.14	31.06	30.98	30.90	30.82	30.74	0.250	0.500
36	38.30	37.44	37.34	37.06	37.14	37.04	36.94	36.84		
42	44.50	43.56	43.44	43.32	43.20	43.08	42.96	42.84		
48	50.80	49.78	49.64	49.50	49.36	49.22	49.08	48.94		
54	57.10	55.96	55.80	55.64	55.48	55.32	55.16	55.00		
Note 1 Reduce I.D. by dimension shown; these figures also apply to C.I. pipe										

Velocity Conversion Tables

Table 4-7. Velocity conversion table (MPS to LPM and LPS)

Nominal pipe size (mm)	MPS 0.3	MPS 0.6	MPS 1.0	MPS 1.5	MPS 2.0	MPS 2.5	MPS 3.0	MPS 5.0	MPS 7.0
(10 mm wall)	LPM	LPM	LPM	LPM	LPM	LPM	LPS	LPS	LPS
50	35	71	118	177	236	294	5.9	10	14
75	80	159	265	398	530	663	13.3	22	31
100	141	283	471	707	942	1178	23.6	39	55
150	318	636	1060	1590	2120	2651	53	88	124
200	565	1130	1885	2827	3770	4712	94	157	220
250	884	1768	2945	4418	5890	7363	147	245	344
300	1272	2544	4241	6361	8482	10602	212	353	495
400	2262	4524	7539	11309	15078	18848	377	628	880

Table 4-8. Velocity conversion table (MPS to LPS and M³/Hr)

Nominal pipe size (mm)	MPS 0.3	MPS 0.6	MPS 1.0	MPS 1.5	MPS 2.0	MPS 2.5	MPS 3.0	MPS 5.0	MPS 7.0
(15 mm wall)	LPS	LPS	LPS	LPS	LPS	LPS	M ³ /Hr	M ³ /Hr	M ³ /Hr
500	59	88	196	295	392	491	35.3	58.9	82.5
600	85	170	283	424	566	707	51	85	119
750	133	266	442	663	884	1104	79.5	132.5	186
1000	236	472	785	1178	1570	1963	141.4	236	330
1200	339	678	1131	1696	2262	2827	204	339	475
1500	530	1060	1767	2651	3534	4418	318	530	

Table 4-9. Velocity conversion table (FPS to GPM)

Nominal pipe size (inches)	Velocity in Feet Per Second (fps)											
	Schedule 40	1/2 fps	1 fps	2 fps	3 fps	4 fps	5 fps	6 fps	8 fps	10 fps	15 fps	20 fps
	GPM	GPM	GPM	GPM	GPM	GPM	GPM	GPM	GPM	GPM	GPM	GPM
1	1.3	2.7	5.4	8	11	13	16	22	27	40	54	
1.5	3.2	6.5	13	19	25	32	38	51	64	95	127	
2	5.2	10.5	21	31	42	52	63	84	105	157	209	
2.5	7.5	15	30	45	60	75	90	119	149	224	299	
3	11.5	23	46	69	92	115	138	184	231	346	461	
4	20	40	80	119	159	199	238	318	397	596	794	
5	31	62	125	187	250	312	374	499	624	936	1248	
6	45	90	180	270	360	451	541	721	901	1352	1802	
8	78	156	312	468	624	780	936	1248	1561	2341	3121	
10	123	246	492	738	984	1230	1476	1968	2460	3690	4920	
12	175	349	698	1047	1397	1746	2095	2793	3492	5237	6983	
14	211	422	844	1266	1688	2110	2532	3376	4220	6330	8440	
16	276	551	1103	1654	2205	2756	3308	4410	5513	8269	11025	
18	349	698	1396	2093	2791	3489	4187	5582	6978	10466	13955	
20	434	867	1734	2602	3469	4336	5203	6938	8672	13008	17344	
24	627	1254	2508	3763	5017	6271	7525	10034	12542	18814	25085	
30	1048	2096	4192	6288	8385	10481	12577	16769	20961	31442	41923	
36	1522	3044	6089	9133	12177	15221	18266	24354	30443	45664	60886	
42	2084	4169	8338	12506	16675	20844	25013	33351	41688	62532	83377	
48	2735	5470	10940	16409	21879	27349	32819	43758	54698	82047	109396	
54	3441	6882	13764	20646	27528	34410	41292	55056	68821	103231	137641	
60	4192	8395	16769	25154	33538	41923	50307	67076	83845	125768	167690	

Index

Numerics

4-20 mA output, specifications 4-3

A

AC power

- requirements 4-3
- troubleshooting 3-2

accuracy 4-2

adaptor, battery 4-3

alarm output, specifications 4-4

analog output

- setting parameters 2-23
- signals 4-3

assessing flow profile 2-5

B

battery

- operation 2-25
- power adaptor/charger 4-3

before installing the unit 2-1

C

cables, transducers 1-2, 4-3

cast iron pipe data 4-10

charger, battery 4-3

checklist for troubleshooting 3-1

clamp-on transducers, dimensions 4-8

connecting

- AC input power 2-13
- DC input power 2-14
- electronics board 2-12
- input power 2-13

conversion tables, velocity 4-12

correction factor 2-22

crystal wedge material 4-3

customer support, EMCO 3-11

D

DC power

- requirements 4-3
- troubleshooting 3-2

dimensions 4-8

- electronics enclosure 4-2
- electronics enclosure, illustration 4-6

transducers 4-2

Doppler flow meter, features 1-1

ductile iron pipe data 4-11

E

ECHO LED

- flashing 3-5
- off 3-3
- unstable readings 2-20

electronics enclosure 4-2

- ambient temperature range 4-2
- board connections 2-12
- dimensions 4-2
- overview 1-2
- weight 4-2

email, customer support 3-11

EMCO customer support 3-11

F

features 1-1

first time operation 2-17

flow requirements

- assessing profile 2-5

flow sensitivity, specification 4-1

fluid conditions, specifications 4-1

front panel 2-17

functional specifications 4-3

H

hi/ low alarms, setting 2-24

high flow rate reading, troubleshooting 3-6

horizontal pipe mounting 2-8, 2-9

I

illustrations

- clamp-on transducer dimensions 4-8
- electrical connections 2-12
- electronics enclosure 4-6
- electronics enclosure mounting 2-13

indications

- rate 4-4
- totalizer 4-5

input power requirements 4-3

inside diameters, pipes 4-9

installation
 horizontal pipe mounting 2-8
 pre-installation procedures 2-2
 procedures 2-9
 straight run requirements 2-5
 tools required 2-2
 vertical pipe mounting 2-8
introduction 1-1

K
K factor, setting 2-22
keypad
 lockout switch 4-4

L
LCD display
 rate selection 2-18
 totalizer selection 2-19
LEDs
 ALARM 2-16
 ECHO 2-20
 indications 2-16
 POWER 2-16
 specifications 4-4
lockout switch, keypad 4-4
low flow cutoff
 setting 2-23
 specifications 4-5
low flow rate reading, troubleshooting 3-6

M
main components 1-2
measurement accuracy 4-2
meters per second, reading 2-24
mounting
 horizontal pipe 2-8
 vertical pipe 2-8

N
normal operation 2-25

O
operating temperature range
 electronics enclosure 4-2
 transducers 4-3
operation
 first time 2-17
 normal 2-25
 portable battery 2-25
output signals

alarms 4-4
analog output 4-3

P
performance specifications 4-1
physical specifications 4-2
pipe conditions, specifications 4-1
pipe data 4-9
 cast iron pipe 4-10
 ductile iron pipe 4-11
 PVC 4-9
 stainless steel 4-9
 steel 4-9
pipe material
 assessing condition 2-5
portable battery operation 2-25
power adaptor 4-3
power failure, backup 4-4
power requirements
 AC 4-3
 DC 4-3
procedures
 connecting power to electronics enclosure
 2-13
 connecting transducers to electronics
 enclosure 2-11
 first time operation 2-18
 mounting the electronics enclosure 2-13
 mounting transducers 2-6
 mounting transducers to the pipe 2-9
process
 determining application requirements 2-3
product introduction 1-1
PVC pipe data 4-9

R
rate indications, units of measure 4-4
rate selection 2-18
reference
 pipe data 4-9
 velocity conversion tables 4-12
reflectors
 air bubbles and particles 1-3
 sonic 1-3
repeatability 4-2
returning units for repair 3-12

S
sales, EMCO contact information 3-11
sensitivity, flow 4-1

- setting parameters
 - advanced 2-22
 - analog output 2-23
 - hi/ low alarms 2-24
 - K factor 2-22
 - low flow cutoff 2-23
 - read meters per second 2-24
 - sample setting 2-22
 - totalizer reset 2-24
 - update time 2-24
- sonic reflectors 1-3
- specifications
 - flow sensitivity 4-1
 - fluid conditions 4-1
 - functional 4-3
 - input power requirements 4-3
 - performance 4-1
 - physical 4-2
 - pipe conditions 4-1
 - velocity of fluid 4-1
- stainless steel pipe data 4-9
- standard pipe data 4-9
- steel pipe data 4-9
- straight run
 - examples 2-7
 - requirements 2-5
- support, EMCO customer support 3-11
- system
 - components 1-2
 - overview 1-1

T

- theory of operation 1-2
- tools for installation 2-2
- totalizer
 - indication, units of measure 4-5
 - reset, setting 2-24
 - selection 2-19
- transducers
 - cable length 4-3
 - cabling 1-2
 - connecting to electronics enclosure 2-11
 - dimensions 4-2
 - housing material 4-2
 - mounting 2-9
 - placement guidelines 2-7
 - positioning guidelines 2-6
 - unstable readings 2-20
 - weight 4-2
- troubleshooting
 - additional information 3-9

- checklist 3-1
- ECHO light flashing 3-5
- erratic flow rate 3-8
- flow rate high or low 3-6
- no ECHO light 3-3
- no power to unit 3-2
- troubleshooting table 3-2
- unstable readings 2-20

U

- unpacking the system 2-1
- update time, setting 2-24

V

- velocity conversion tables 4-12
- velocity, measurable fluid 4-1
- vertical pipe mounting 2-8
- voltage selector switch 2-13

W

- warranty
 - authorized returns 3-13
 - filing a claim 3-12
 - returning units 3-13
 - statement 3-13
- web site, EMCO 3-11
- wedge material, crystal 4-3

