

Instruction Manual

IB-106-300NH Rev. 4.2

July 2002

World Class 3000

Oxygen Analyzer
with IFT 3000 Intelligent
Field Transmitter



ROSEMOUNT[®]
Analytical

<http://www.processanalytic.com>

EMERSON[™]
Process Management

ESSENTIAL INSTRUCTIONS

READ THIS PAGE BEFORE PROCEEDING!

Rosemount Analytical designs, manufactures and tests its products to meet many national and international standards. Because these instruments are sophisticated technical products, you **MUST properly install, use, and maintain them** to ensure they continue to operate within their normal specifications. The following instructions **MUST be adhered to** and integrated into your safety program when installing, using, and maintaining Rosemount Analytical products. Failure to follow the proper instructions may cause any one of the following situations to occur: Loss of life; personal injury; property damage; damage to this instrument; and warranty invalidation.

- **Read all instructions** prior to installing, operating, and servicing the product.
- If you do not understand any of the instructions, **contact your Rosemount Analytical representative** for clarification.
- **Follow all warnings, cautions, and instructions** marked on and supplied with the product.
- **Inform and educate your personnel in the proper installation, operation, and maintenance of the product.**
- **Install your equipment as specified in the Installation Instructions of the appropriate Instruction Manual and per applicable local and national codes.** Connect all products to the proper electrical and pressure sources.
- To ensure proper performance, **use qualified personnel** to install, operate, update, program, and maintain the product.
- When replacement parts are required, ensure that qualified people use replacement parts specified by Rosemount. Unauthorized parts and procedures can affect the product's performance, place the safe operation of your process at risk, **and VOID YOUR WARRANTY.** Look-alike substitutions may result in fire, electrical hazards, or improper operation.
- **Ensure that all equipment doors are closed and protective covers are in place, except when maintenance is being performed by qualified persons, to prevent electrical shock and personal injury.**

CAUTION

If a Model 275 Universal HART[®] Communicator is used with this unit, the software within the Model 275 may require modification. If a software modification is required, please contact your local Fisher-Rosemount Service Group or National Response Center at 1-800-654-7768.

The information contained in this document is subject to change without notice.

Emerson Process Management

Rosemount Analytical Inc. Process Analytic Division

1201 N. Main St.
Orrville, OH 44667-0901
T (330) 682-9010
F (330) 684-4434
e-mail: gas.csc@EmersonProcess.com
<http://www.processanalytic.com>



HIGHLIGHTS OF CHANGES

Effective May, 1999 Rev. 4.0

Page	Summary
Page P-6	Added new Quick Start Guide.
Page 3-1	Added Section 3, Setup.
Page 4-1	Removed calibration information from Operation section, and created Section 4, Calibration.
Page 6-2	Expanded explanations of IFT status codes.
Section 6	Added new troubleshooting procedures.

Effective November, 2001 Rev. 4.1

Page	Summary
Highlights	Updated Highlights of Changes Appendix A page.
Appendix A	Replaced Appendix A, Rev. 3.6 with Rev. 3.7.

Effective July, 2002 Rev. 4.2

Page	Summary
Highlights	Updated Highlights of Changes Appendix A page.
Page 4-1	Added reference to new Calibration Record sheet.
Page 4-9	Added new Calibration Record sheet.
Appendix A	Replaced Appendix A, Rev. 3.7 with Rev. 3.8.

HIGHLIGHTS OF CHANGES

APPENDIX A

Effective May, 1996 Rev. 3

Page	Summary
--	General. Updated appendix to reflect probe design changes.
Page A-13	Added "Extended temperature by-pass arrangements" to Figure A-13 (Sheet 3 of 3)

Effective June, 1996 Rev. 3.1

Page	Summary
Page A-13	Updated part ordering information.

Effective August, 1996 Rev. 3.2

Page	Summary
Page A-25	Updated cell replacement kit part numbers for the probe.

Effective October, 1996 Rev. 3.3

Page	Summary
Page A-6	Added NOTE to Figure A-7.

Effective January, 1997 Rev. 3.4

Page	Summary
Page A-1	Added warning to read new safety instructions.
Page A-12	Added protective covers and grounds warning.
Page A-16	Added protective covers and grounds warning.

Effective February, 1998 Rev. 3.5

Page	Summary
Page A-18	Changed screw torque in paragraph A-11h.

Effective July, 1998 Rev. 3.6

Page	Summary
--	Changed test gas to calibration gas and reference gas to reference air throughout the appendix.

HIGHLIGHTS OF CHANGES (CONTINUED)

Effective November, 2001 Rev. 3.7

Page	Summary
A-8	Added new cup type diffusion assembly description, paragraph A-6.e. and diffusion assembly illustrations, Figure A-13 and A-14.
A-26	Added new cup type diffusion assembly part numbers 4851B89G04 and 4851B90G04 to replacement parts list. Deleted stainless steel diffuser assembly from replacement parts list.

Effective July, 2002 Rev. 3.8

Page	Summary
A-13	Added troubleshooting symptoms 5 and 6 to Table A-2.

HIGHLIGHTS OF CHANGES

APPENDIX B

Effective February, 1992 Rev. 2

Page	Summary
Page B-1	Figure B-1. New HPS 3000 Optional Class 1, Division 1, Group B (IP56) Explosion-Proof Enclosure added.
Page B-11	Figure and Index No. column added to Table B-2. Replacement Parts for Heater Power Supply.

Effective January, 1995 Rev. 2.1

Page	Summary
Page B-3	Updated Figure B-3, Heater Power Supply Block Diagram for IB consistency.

Effective January, 1997 Rev. 2.2

Page	Summary
Page B-1	Added warning to read new safety instructions.
Page B-3	Corrected Table B-1 specifications list.
Page B-4	Added protective covers and grounds warning.
Page B-8	Added protective covers and grounds warning.
Page B-11	Added expanded fuse description.

HIGHLIGHTS OF CHANGES APPENDIX D

Effective June, 1994 Rev. 2

Page	Summary
Page D-1	MPS outline drawing changed to show new MPS.
Page D-2	MPS interior view replaced with new MPS in Figure D-2.
Page D-3	"Optional" for check valve deleted in Figure D-3.
Page D-4	Drawing showing location of optional Z-Purge added as Figure D-4.
Page D-7	Power supply replacement procedures in paragraph D-7 changed to reflect new design in the MPS. Solenoid valve replacement procedures in paragraph D-8 changed to reflect new design in the MPS.
Page D-8	Old exploded view of MPS replaced with new MPS.
Page D-10	Paragraph D-11, Adding Probes to the new MPS, added.
Page D-11	Change part numbers for the power supply, solenoid valve, and test gas flowmeter assembly. Add part numbers for reference gas flowmeter assembly and all the parts in the probe adder kit.

Effective January, 1995 Rev. 2.1

Page	Summary
Page D-1	Updated Figure D-1, MPS 3000 to include hinge.

Effective May, 1996 Rev. 2.2

Page	Summary
Page D-11	Updated replacement parts list to reflect new part numbers.

Effective January, 1997 Rev. 2.3

Page	Summary
Page D-1	Added warning to read new safety instructions.
Page D-2	Corrected Table D-1 Specifications listing, 1 st entry.
Page D-5	Added protective covers and grounds warning.
Page D-7	Added protective covers and grounds warning, corrected item number errors in paragraph D-6.
Page D-11	Added expanded fuse descriptions.

Effective July, 1998 Rev. 2.4

Page	Summary
---	Changed test gas to calibration gas and reference gas to reference air throughout the appendix.

HIGHLIGHTS OF CHANGES

APPENDIX E

Effective May, 1996 Rev. 4

Page	Summary
---	General. Updated text and illustrations to reflect new version of IFT.
Page E-4	Updated IFT display status codes and placed in priority sequence.

Effective June, 1996 Rev. 4.1

Page	Summary
Page E-2	Updated specification table.

Effective October, 1996 Rev. 4.2

Page	Summary
Page E-4	Added new status displays for password protection features.

Effective January, 1997 Rev. 4.3

Page	Summary
Front matter	Added "Safety instructions for the wiring and installation of this apparatus."
Page E-1	Added warning to read new safety instructions.
Page E-2	Deleted NOTE.
Page E-4	Added protective covers and grounds warning.
Page E-8	Added protective covers and grounds warning.
Page E-15	Added expanded fuse description.

Effective July, 1998 Rev. 4.4

Page	Summary
---	Changed test gas to calibration gas throughout the appendix.

Effective June, 1999 Rev. 4.5

Page	Summary
Page E-1	Changed "real time clock" to "timer".

HIGHLIGHTS OF CHANGES

APPENDIX J

Effective April, 1995 Rev. 1

Page	Summary
Page J-13	Added statement of reference to the return authorization number.

Effective June, 1995 Rev. 1.1

Page	Summary
—	Figure J-4. Updated figure to include "Status group" and "K3 eff" in calculations.

TABLE OF CONTENTS

PREFACE	P-1
Definitions.....	P-1
Safety Instructions.....	P-2
Glossary of Terms.....	P-3
Quick Start Guide.....	P-6
1-0 DESCRIPTION AND SPECIFICATIONS	1-1
1-1 Component Checklist of Typical System (Package Contents).....	1-1
1-2 System Overview.....	1-2
2-0 INSTALLATION	2-1
2-1 Oxygen Analyzer (Probe) Installation.....	2-1
2-2 Intelligent Field Transmitter (IFT) Installation.....	2-9
2-3 Heater Power Supply Installation.....	2-14
2-4 Multiprobe Calibration Gas Sequencer Installation.....	2-22
3-0 SETUP	3-1
3-1 Overview.....	3-1
3-2 Configuring the Analog Output.....	3-1
3-3 Setting Calibration Parameters.....	3-1
3-4 Setting the O ₂ Alarm Setpoints.....	3-2
3-5 Configuring Efficiency Calculations.....	3-2
3-6 Configuring the Relay Outputs.....	3-2
4-0 CALIBRATION	4-1
4-1 Analog Output Calibration.....	4-1
4-2 System Calibration.....	4-1
5-0 GENERAL USER INTERFACE (GUI) OPERATION	5-1
5-1 Overview.....	5-1
5-2 Deluxe Version IFT Displays and Controls.....	5-2
5-3 Help Key.....	5-3
5-4 Status Line.....	5-3
5-5 Quick Reference Chart.....	5-3
5-6 Main Menu.....	5-3
5-7 Probe Data Sub-Menu.....	5-3
5-8 Calibrate O ₂ Sub-Menu.....	5-4
5-9 Setup Sub-Menu.....	5-4
6-0 TROUBLESHOOTING	6-1
6-1 Overview.....	6-1
6-2 Special Troubleshooting Notes.....	6-1
6-3 System Troubleshooting.....	6-1
6-4 Heater Problem.....	6-3
6-5 Cell Problem.....	6-5
6-6 IFT Problem.....	6-7
6-7 MPS Problem.....	6-8
6-8 Performance Problem (Process Response is Suspect).....	6-9

7-0 RETURN OF MATERIAL..... 7-1

8-0 APPENDICES 8-1

Appendix A A-1

Appendix B B-1

Appendix D D-1

Appendix E E-1

Appendix J J-1

9-0 INDEX..... 9-1

LIST OF ILLUSTRATIONS

Figure 1. Complete World Class 3000 System P-5

Figure 2. Wiring Layout for World Class 3000 System without HPS or MPS P-8

Figure 1-1. Typical System Package 1-1

Figure 1-2. Typical System Installation 1-5

Figure 1-3. World Class 3000 Typical Application with Intelligent Field Transmitters 1-6

Figure 2-1. Probe Installation 2-2

Figure 2-2. Orienting the Optional Vee Deflector 2-7

Figure 2-3. Air Set, Plant Air Connection 2-8

Figure 2-4. Outline of Intelligent Field Transmitter 2-9

Figure 2-5. Power Supply Board Jumper Configuration 2-10

Figure 2-6. Signal Wire Routing 2-11

Figure 2-7. IFT Power Supply Board Jumpers 2-12

Figure 2-8. Wiring Layout for IFT Systems without HPS 2-13

Figure 2-9. Microprocessor Board Jumper Configuration 2-14

Figure 2-10. IFT Microprocessor Board 2-15

Figure 2-11. Interconnect Board Jumper Configuration 2-16

Figure 2-12. IFT Interconnect Board Output Connections 2-16

Figure 2-13. Outline of Heater Power Supply 2-17

Figure 2-14. Wiring Layout for Complete IFT 3000 System with HPS (Sheet 1 of 2) 2-18

Figure 2-15. Heater Power Supply Wiring Connections 2-20

Figure 2-16. Jumper Selection Label 2-21

Figure 2-17. Jumpers on HPS Mother Board 2-21

Figure 2-18. MPS Module 2-22

Figure 2-19. MPS Gas Connections 2-23

Figure 2-20. MPS Probe Wiring 2-24

Figure 4-1. Typical Calibration Setup 4-4

Figure 4-2. Portable Rosemount Oxygen Calibration Gas Kit 4-5

Figure 4-3. Typical Portable Calibration Setup 4-6

Figure 4-4. Typical Automatic Calibration System 4-7

Figure 5-1. Deluxe Version IFT Displays and Controls 5-2

Figure 5-2. Quick Reference Chart 5-5

LIST OF TABLES

Table 4-1.	Automatic Calibration Parameters	4-8
Table 5-1.	Sample HELP Messages	5-3
Table 5-2.	MAIN menu	5-3
Table 5-3.	PROBE DATA Sub-Menu	5-4
Table 5-4.	CALIBRATE O ₂ Sub-Menu	5-10
Table 5-5.	SETUP Sub-Menu	5-12
Table 5-6.	Efficiency Constants	5-14
Table 6-1.	IFT Status Codes	6-2
Table 6-2.	Heater Troubleshooting	6-3
Table 6-3.	Cell Troubleshooting	6-5
Table 6-4.	IFT Troubleshooting	6-7
Table 6-5.	MPS Troubleshooting	6-8
Table 6-6.	Performance Problem Troubleshooting	6-9



Only one probe can be calibrated at a time.
Probe calibrations must be scheduled
appropriately in multiple probe applications.

PREFACE

The purpose of this manual is to provide a comprehensive understanding of the World Class 3000 Oxygen Analyzer components, functions, installation, and maintenance.

This manual is designed to provide information about the World Class 3000 Oxygen Analyzer. We recommend that you familiarize yourself with the Overview and Installation sections before installing your emissions monitor.

The overview presents the basic principles of the oxygen analyzer along with its performance characteristics and components. The remaining sections contain detailed procedures and information necessary to install and service the oxygen analyzer.

DEFINITIONS

The following definitions apply to WARNINGS, CAUTIONS, and NOTES found throughout this publication.

WARNING

Highlights an operation or maintenance procedure, practice, condition, statement, etc. If not strictly observed, could result in injury, death, or long-term health hazards of personnel.

CAUTION

Highlights an operation or maintenance procedure, practice, condition, statement, etc. If not strictly observed, could result in damage to or destruction of equipment, or loss of effectiveness.

NOTE

Highlights an essential operating procedure, condition, or statement.

⊕ : EARTH (GROUND) TERMINAL

⊕ : PROTECTIVE CONDUCTOR TERMINAL

⚠ : RISK OF ELECTRICAL SHOCK

⚠ : WARNING: REFER TO INSTRUCTION BULLETIN

NOTE TO USERS

The number in the lower right corner of each illustration in this publication is a manual illustration number. It is not a part number, and is not related to the illustration in any technical manner.

IMPORTANT

SAFETY INSTRUCTIONS FOR THE WIRING AND INSTALLATION OF THIS APPARATUS

The following safety instructions apply specifically to all EU member states. They should be strictly adhered to in order to assure compliance with the Low Voltage Directive. Non-EU states should also comply with the following unless superseded by local or National Standards.

1. Adequate earth connections should be made to all earthing points, internal and external, where provided.
2. After installation or troubleshooting, all safety covers and safety grounds must be replaced. The integrity of all earth terminals must be maintained at all times.
3. Mains supply cords should comply with the requirements of IEC227 or IEC245.
4. All wiring shall be suitable for use in an ambient temperature of greater than 75°C.
5. All cable glands used should be of such internal dimensions as to provide adequate cable anchorage.
6. To ensure safe operation of this equipment, connection to the mains supply should only be made through a circuit breaker which will disconnect all circuits carrying conductors during a fault situation. The circuit breaker may also include a mechanically operated isolating switch. If not, then another means of disconnecting the equipment from the supply must be provided and clearly marked as such. Circuit breakers or switches must comply with a recognized standard such as IEC947. All wiring must conform with any local standards.
7. Where equipment or covers are marked with the symbol to the right, hazardous voltages are likely to be present beneath. These covers should only be removed when power is removed from the equipment — and then only by trained service personnel.
8. Where equipment or covers are marked with the symbol to the right, there is a danger from hot surfaces beneath. These covers should only be removed by trained service personnel when power is removed from the equipment. Certain surfaces may remain hot to the touch.
9. Where equipment or covers are marked with the symbol to the right, refer to the Operator Manual for instructions.
10. All graphical symbols used in this product are from one or more of the following standards: EN61010-1, IEC417, and ISO3864.

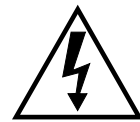

GLOSSARY OF TERMS

Abrasive Shield

An optional component that shields the probe from high velocity particulate entrained in the flue gas stream.

Automatic Calibration

An automatic calibration can only be performed if the system is equipped with an MPS 3000 Multiprobe Calibration Gas Sequencer. Once a calibration is initiated by the operator or by the IFT on a scheduled interval, all calibration actions are performed by the IFT. The MPS switched calibration gases under direction from the IFT.

Calibration

The process of measuring gases of a known concentration, and comparing that known concentration to the actual values sensed by the instrument. After reading the calibration gases, the IFT automatically adjusts the slope and constant values to ensure that the system is correctly reading the process gas O₂ values.

Cold Junction Compensation

A method for compensating for the small voltage developed at the junction of the thermocouple leads in the probe junction box.

Dead Band

The range through which a signal can be varied without initiating a response. In the IFT 3000, dead band is used to prevent an oxygen signal near an alarm setpoint from cycling the alarm on and off.

GUI

General User Interface. The GUI is the operator interface for the IFT 3000.

HART

A communications protocol using frequency shift keying (FSK) to transmit data on an analog output line without affecting the analog output signal.

HPS

Heater Power Supply. An HPS should be used to provide power for the probe heater if the probe is more than 150 ft (45 m) from the IFT.

IFT

Intelligent Field Transmitter.

In Situ

A method of analyzing process gases without removing them from the process stream.

MPS

Multiprobe Calibration Gas Sequencer. The MPS can provide automatic calibration gas sequencing for up to four probes.

Reference Air

Provides a known oxygen concentration to the reference side of the oxygen sensing cell.

Semiautomatic Calibration

Semiautomatic calibration is performed when the system does not include an MPS 3000 Multi-probe Calibration Gas Sequencer. The IFT 3000 provides prompts to direct the user to switch calibration gases when performing the calibration.

Thermocouple

An electrical device made of two dissimilar metals. A thermocouple develops a millivolt signal proportional to its temperature.

Vee Deflector

Protects the optional ceramic diffusor from the process gases. The vee deflector must be positioned so it points toward the direction of the process gas flow. See Figure 2-2 for an illustration of the vee deflector.

WHAT YOU NEED TO KNOW

BEFORE INSTALLING AND WIRING A ROSEMOUNT IFT 3000 INTELLIGENT FIELD TRANSMITTER WITH WORLD CLASS 3000 PROBE

1. What is the line voltage being supplied to the IFT 3000?
Write the line voltage here _____
2. Use the following drawing, Figure 1, to identify which parts of the World Class 3000 system are included in your system. Components in the shaded area are optional components.

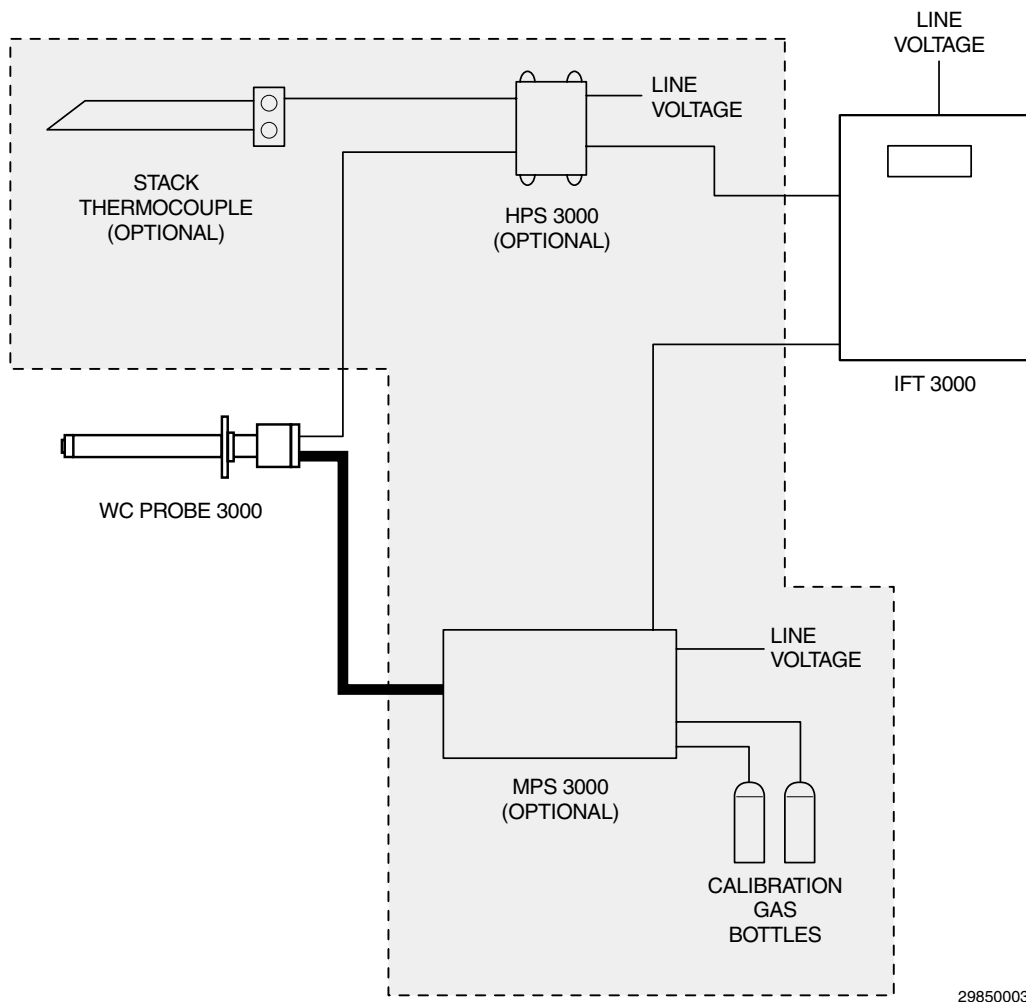

Figure 1. Complete World Class 3000 System

29850003

QUICK START GUIDE

Use this Quick Start Guide if ...

1. You are using a World Class 3000 probe.
2. You are NOT using any optional components. Optional components are shown in the shaded area in Figure 1.
3. You are familiar with the installation requirements for the IFT 3000 Intelligent Field Transmitter and World Class 3000 probe.
4. You are familiar with the procedures for changing the jumpers located in the IFT 3000, as described in Section 2, Installation.

If you cannot use the Quick Start Guide, turn to Section 2, Installation, in this Instruction Bulletin.

QUICK START GUIDE FOR IFT 3000 SYSTEMS

Before using the Quick Start Guide, please read “WHAT YOU NEED TO KNOW BEFORE INSTALLING AND WIRING A ROSEMOUNT IFT 3000 INTELLIGENT FIELD TRANSMITTER WITH WORLD CLASS 3000 PROBE” on the preceding page.

1. Install the probe in an appropriate location on the stack or duct. Refer to Section 2, paragraph 2-1a for information on selecting a location for the probe.
2. Connect calibration gas and reference air to the probe.
3. Verify the jumper selection on the IFT 3000 power supply board, microprocessor board, and interconnect board, as shown in Figure 2.
4. Install the IFT 3000 in the desired location. Refer to Section 2, paragraph 2-2a for information on selecting a location for the IFT 3000.
5. Wire the probe to the IFT as shown in Figure 2.
6. Connect line voltage to the IFT as shown in Figure 2.
7. Apply power to the IFT 3000. Allow sufficient time for the probe to reach normal operating temperature. The time required will vary based on process temperature and other variables.
8. Perform a manual (semiautomatic) calibration. Press the CAL key on the GUI. Select the PERFORM CALIBRATION sub-menu. “Press ENTER to start Manual Calibration” will appear on the LCD display. Press ENTER to start the calibration process. Follow the instructions on the LCD display. Refer to Section 4, Calibration, for more information on performing a calibration.

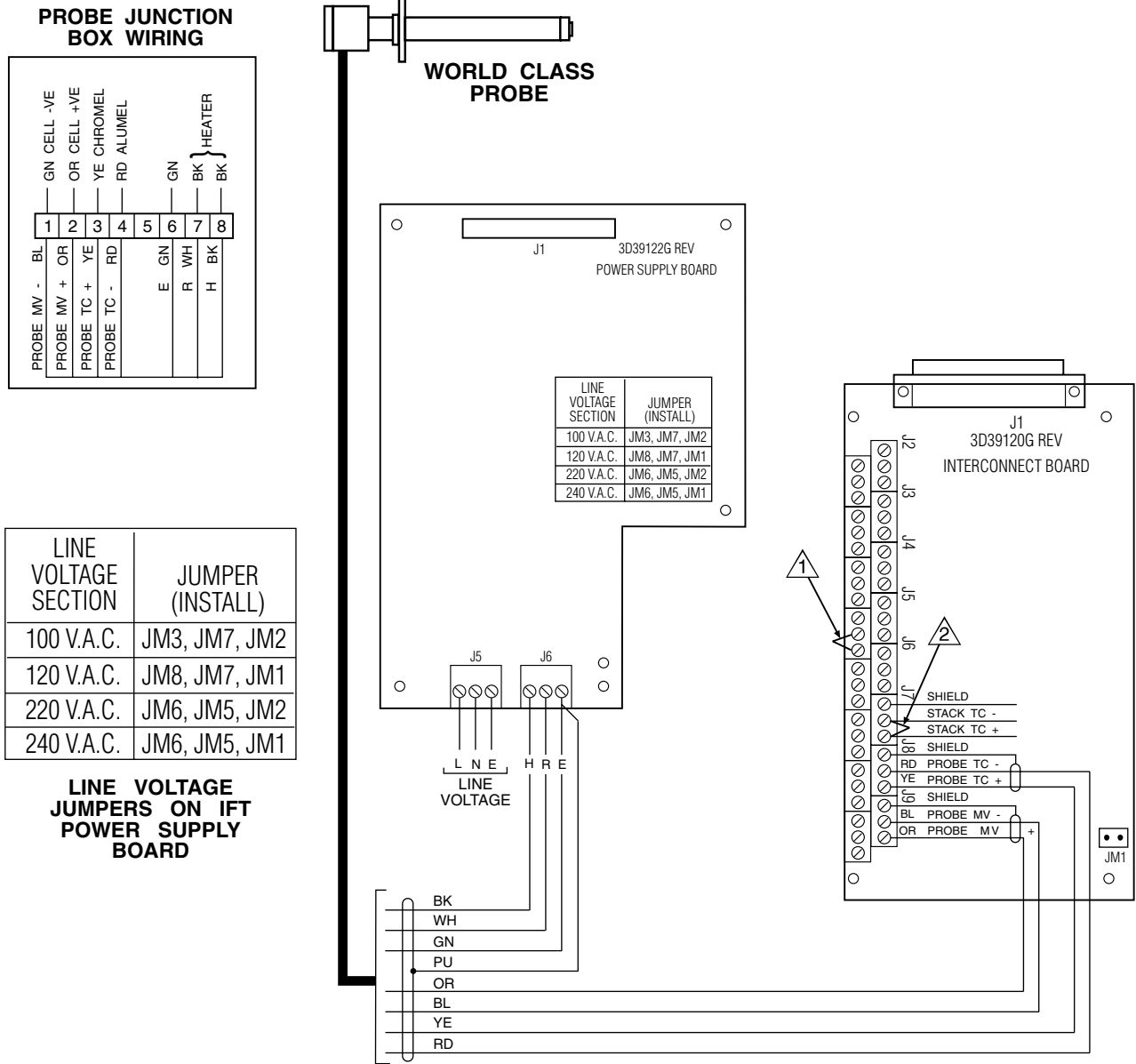

NOTES:

- ① INSTALL JUMPER ACROSS TERMINALS 13 AND 14.
- ② INSTALL JUMPER ACROSS TERMINALS 7 AND 8.

29850002

Figure 2. Wiring Layout for World Class 3000 System without HPS or MPS

QUICK REFERENCE GUIDE IFT 3000 INTELLIGENT FIELD TRANSMITTER

Performing a Manual (Semiautomatic) Calibration

1. Connect the high calibration gas to the probe fitting.
2. Press the CAL key.
3. Select the PERFORM CALIBRATION sub-menu.
4. Press the ENTER key.
5. Turn on the high calibration gas.
6. When the O₂ reading is stable, press ENTER.
7. Turn off the high calibration gas and turn on the low calibration gas.
8. Press Enter.
9. When the O₂ reading is stable, press ENTER.
10. The LCD display will show "Resistance Check". When the display changes to "Turn off low calibration gas", turn off the low calibration gas and press ENTER.
11. When the oxygen reading has stabilized at the process value, press ENTER.

Setting up the Analog Output

1. Press the SETUP key.
2. Select the Analog Output sub-menu.
3. Set the SOURCE to O₂. For information on configuring the analog output for Efficiency or Dual Range O₂, refer to Section V, Operation.
4. Set the AOUT TYPE to the desired setting. Note that the setting must agree with the position of the analog output selector switch. If you will communicate with the IFT using HART communications, the AOUT TYPE must be set to HART 4-20mA.
5. Select Range Setup and press ENTER.
6. Set the Xfer Fnct to Lin or Log, as desired.
7. Select Range Values and press ENTER.
8. Set the High End to the oxygen concentration to be represented by the high analog output value, i.e., 20mA or 10V.
9. Set the Low End to the oxygen concentration to be represented by the low analog output value, i.e., 0 or 4mA or 0V.
10. Press the ESC key until you are back at the Main menu.

HART COMMUNICATOR FAST KEY SEQUENCES

Perform Calibration	<table border="1"><tr><td>2</td><td>3</td><td>1</td><td>3</td></tr></table>	2	3	1	3	Analog Output Upper Range Value	<table border="1"><tr><td>3</td><td>2</td><td>4</td></tr></table>	3	2	4
2	3	1	3							
3	2	4								
Trim Analog Output	<table border="1"><tr><td>2</td><td>4</td></tr></table>	2	4	Analog Output Lower Range Value	<table border="1"><tr><td>3</td><td>2</td><td>5</td></tr></table>	3	2	5		
2	4									
3	2	5								
Toggle Analog Output Tracking	<table border="1"><tr><td>2</td><td>3</td><td>1</td><td>2</td></tr></table>	2	3	1	2	View O ₂ Value	<table border="1"><tr><td>1</td><td>1</td><td>1</td></tr></table>	1	1	1
2	3	1	2							
1	1	1								
View Analog Output	<table border="1"><tr><td>1</td><td>2</td><td>1</td></tr></table>	1	2	1						
1	2	1								

Technical Support Hotline:

For assistance with technical problems, please call the Customer Support Center (CSC). The CSC is staffed 24 hours a day, 7 days a week.

Phone: 1-800-433-6076

In addition to the CSC, you may also contact Field Watch. Field Watch coordinates Rosemount's field service throughout the US and abroad.

Phone: 1-800-654-RSMT (1-800-654-7768)

Rosemount may also be reached via the Internet through e-mail and the World Wide Web:

E-mail: GAS.CSC@emersonprocess.com
World Wide Web: www.processanalytic.com

SECTION 1 DESCRIPTION AND SPECIFICATIONS

1-1 COMPONENT CHECKLIST OF TYPICAL SYSTEM (PACKAGE CONTENTS)

A typical Rosemount World Class 3000 Oxygen Analyzer with IFT 3000 Intelligent Field Trans-

mitter should contain the items shown in Figure 1-1. Record the part number, serial number, and order number for each component of your system in the table located on the first page of this manual.

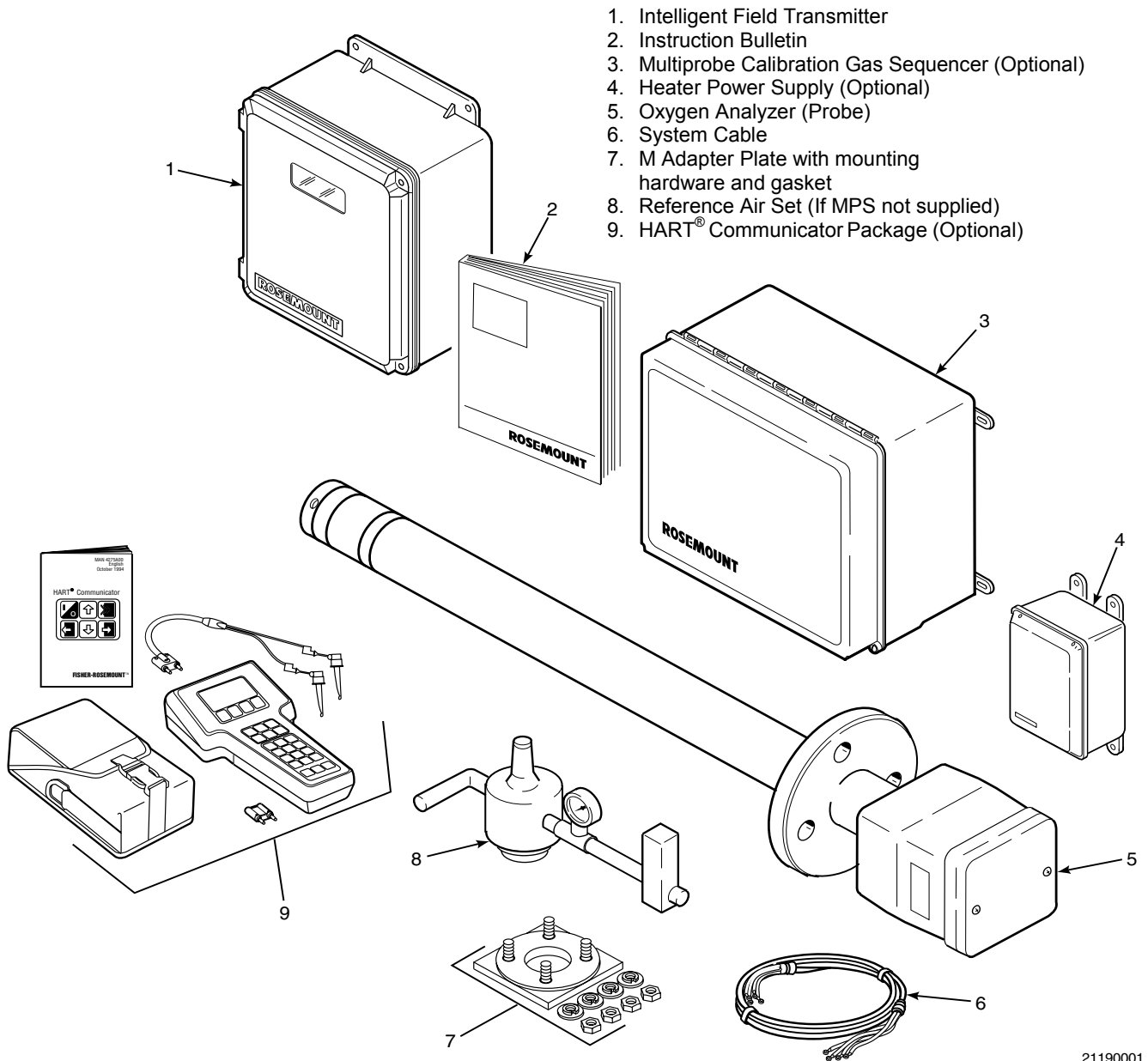

1. Intelligent Field Transmitter
2. Instruction Bulletin
3. Multiprobe Calibration Gas Sequencer (Optional)
4. Heater Power Supply (Optional)
5. Oxygen Analyzer (Probe)
6. System Cable
7. M Adapter Plate with mounting hardware and gasket
8. Reference Air Set (If MPS not supplied)
9. HART® Communicator Package (Optional)

21190001

Figure 1-1. Typical System Package

1-2 SYSTEM OVERVIEW

a. Scope

This Instruction Bulletin has been designed to supply details needed to install, startup, operate, and maintain the Rosemount World Class 3000 Oxygen Analyzer with IFT 3000 Intelligent Field Transmitter. The Intelligent Field Transmitter (IFT) can be interfaced with one World Class 3000 probe. The IFT provides all necessary intelligence for controlling the probe and optional MPS 3000 Multiprobe Calibration Gas Sequencer. Appendices at the back of this manual detail each component and option from the standpoint of troubleshooting, repair, and spare parts.

Operator/Technician interface to the IFT can be provided from the displays and keypads on the front panel, and remotely through HART® communications protocol, utilizing the 4-20 mA out-put signal from the IFT interconnect board. HART Communicator IFT applications are detailed in Appendix J.

b. System Description

The Rosemount Oxygen Analyzer (Probe) is designed to measure the net concentration of oxygen in an industrial process; i.e., the oxygen remaining after all fuels have been oxidized. The probe is permanently positioned within an exhaust duct or stack and performs its task without the use of a sampling system.

The equipment measures oxygen percentage by reading the voltage developed across a heated electrochemical cell, which consists of a small yttria-stabilized, zirconia disc. Both sides of the disc are coated with porous metal electrodes. When operated at the proper temperature, the millivolt output voltage of the cell is given by the following Nernst equation:

$$EMF = KT \log_{10}(P1/P2) + C$$

Where:

1. P2 is the partial pressure of the oxygen in the measured gas on one side of the cell,
2. P1 is the partial pressure of the oxygen in the reference air on the other side,
3. T is the absolute temperature,
4. C is the cell constant,
5. K is an arithmetic constant.

NOTE

For best results, use clean, dry, instrument air (20.95% oxygen) as a reference air.

When the cell is at operating temperature and there are unequal oxygen concentrations across the cell, oxygen ions will travel from the high partial pressure of oxygen side to the low partial pressure side of the cell. The resulting logarithmic output voltage is approximately 50 mV per decade. Because the magnitude of the output is proportional to the logarithm of the inverse of the sample of the oxygen partial pressure, the output signal increases as the oxygen concentration of the sample gas decreases. This characteristic enables the oxygen analyzer to provide exceptional sensitivity at low oxygen concentrations.

Oxygen analyzer equipment measures net oxygen concentration in the presence of all the products of combustion, including water vapor. Therefore, it may be considered an analysis on a "wet" basis. In comparison with older methods, such as the Orsat apparatus, which provides an analysis on a "dry" gas basis, the "wet" analysis will, in general, indicate a lower percentage of oxygen. The difference will be proportional to the water content of the sampled gas stream.

c. System Configuration

The equipment covered in this manual consists of three major components: the oxygen analyzer (probe), the intelligent field transmitter (IFT), and an optional heater power supply (HPS). The HPS is required where the cable run between the probe and the electronics is greater than 150 ft (45 m). There is also an optional multiprobe calibration gas sequencer (MPS) to facilitate automatic calibration of the probe.

Probes are available in five length options, giving the user the flexibility to use an in situ penetration appropriate to the size of the stack or duct. The options on length are 18 in. (457 mm), 3 ft (0.91 m), 6 ft (1.83 m), 9 ft (2.7 m), or 12 ft (3.66 m).

The IFT contains electronics that control probe temperature (in conjunction with the optional HPS), supply power, and provide isolated outputs that are proportional to the measured oxygen concentration. The oxygen sensing cell is maintained at a constant temperature by modulating the duty cycle of the probe heater. The IFT accepts millivolt signals generated by the sensing cell and produces outputs to be used by remotely connected devices. The IFT output is isolated and selectable to provide linearized voltage or current.

The heater power supply (HPS) can provide an interface between the IFT and the probe. The HPS contains a transformer for supplying proper voltage to the probe heater. The enclosure has been designed to meet NEMA 4X (IP56) specifications for water tightness; an optional enclosure to meet Class 1, Division 1, Group B (IP56) explosion proof is also available.

Systems with multiprobe and multiple IFT applications may employ an optional MPS 3000 Multiprobe Calibration Gas Se-

quencer. The MPS 3000 provides automatic calibration gas sequencing for up to four probes and IFTs to accommodate automatic calibration.

d. System Features

1. Unique and patented electronic cell protection action that automatically protects sensor cell when the analyzer detects reducing atmospheres.
2. Output voltage and sensitivity increase as the oxygen concentration decreases.
3. User friendly, menu driven operator interface with context-sensitive on-line help.
4. Field replaceable cell.
5. Analyzer constructed of rugged 316 LSS for all wetted parts.
6. The intelligent field transmitter (IFT) can be located up to 150 ft (45 m) from the probe when used without optional heater power supply (HPS). When the system includes the optional HPS, the HPS can be located up to 150 ft (45 m) from the probe and the IFT may be located up to 1200 ft (364 m) from the HPS.
7. All electronic modules are adaptable to 100, 120, 220, and 240 line voltages.
8. Five languages may be selected for use with the Intelligent Field Transmitter:

English	Italian
French	Spanish
German	

9. An operator can set up, calibrate, or troubleshoot the IFT in one of two ways:
- (a) Optional General User Interface (GUI). The GUI is housed within the IFT electronics enclosure and makes use of an LCD and keypad.
 - (b) Optional HART Interface. The IFT's 4-20 mA output line transmits an analog signal proportional to oxygen level. The line also carries all information normally accessed by use of the General User Interface LCD and keypad. This information can be accessed through the following:
 - 1 Rosemount Model 275 Hand-held Communicator - The handheld communicator requires Device Descriptor (DD) software specific to the World Class 3000 product. The DD software will be supplied with many model 275 units, but can also be programmed into existing units at most Fisher-Rosemount service offices.
 - 2 Personal Computer (PC) - The use of a personal computer requires Cornerstone software with Module Library (ModLib) specific to the World Class 3000 product.
 - 3 Selected Distributed Control Systems - The use of distributed control systems requires input/output (I/O) hardware and software which permit HART communications.

e. Handling the Oxygen Analyzer.

CAUTION

It is important that printed circuit boards and integrated circuits are handled only when adequate antistatic precautions have been taken to prevent possible equipment damage.

The oxygen analyzer is designed for industrial application. Treat each component of the system with care to avoid physical damage. The probe contains components made from ceramics, which are susceptible to shock when mishandled.

NOTE

Retain packaging in which the oxygen analyzer arrived from the factory in case any components are to be shipped to another site. This packaging has been designed to protect the product.

f. System Considerations

Prior to installation of your Rosemount World Class 3000 Oxygen Analyzer with Intelligent Field Transmitter make sure that you have all of the components necessary to make the system installation. Ensure that all the components are properly integrated to make the system functional.

Once you have verified that you have all the components, select mounting locations and determine how each component will be placed in terms of available power supply, ambient temperatures, environmental considerations, convenience, and serviceability. A typical system installation is illustrated in Figure 1-2. Figure 1-3 shows a typical system wiring. For details on installing the individual components of the system, refer to Section 2, Installation.

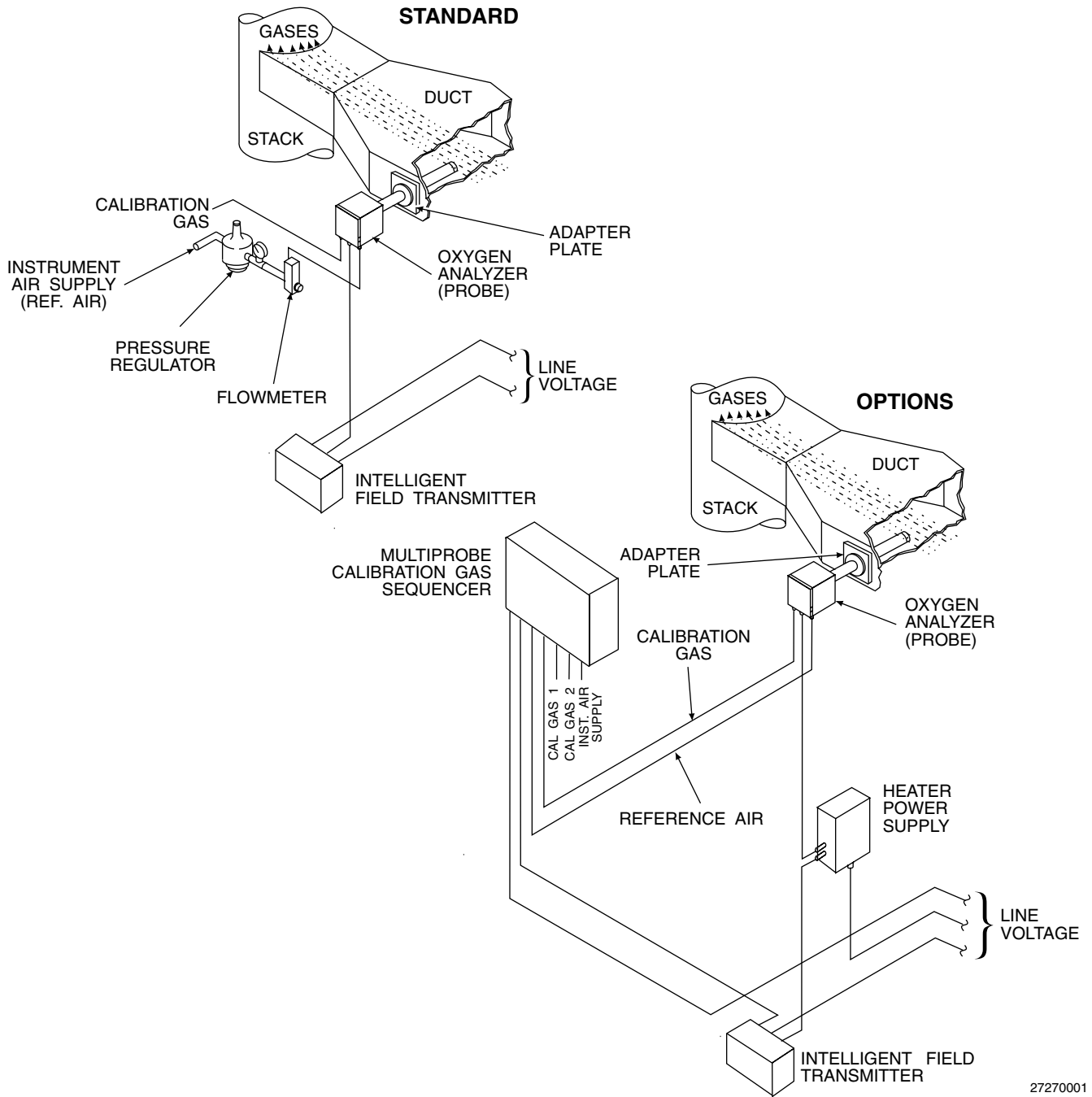

27270001

Figure 1-2. Typical System Installation

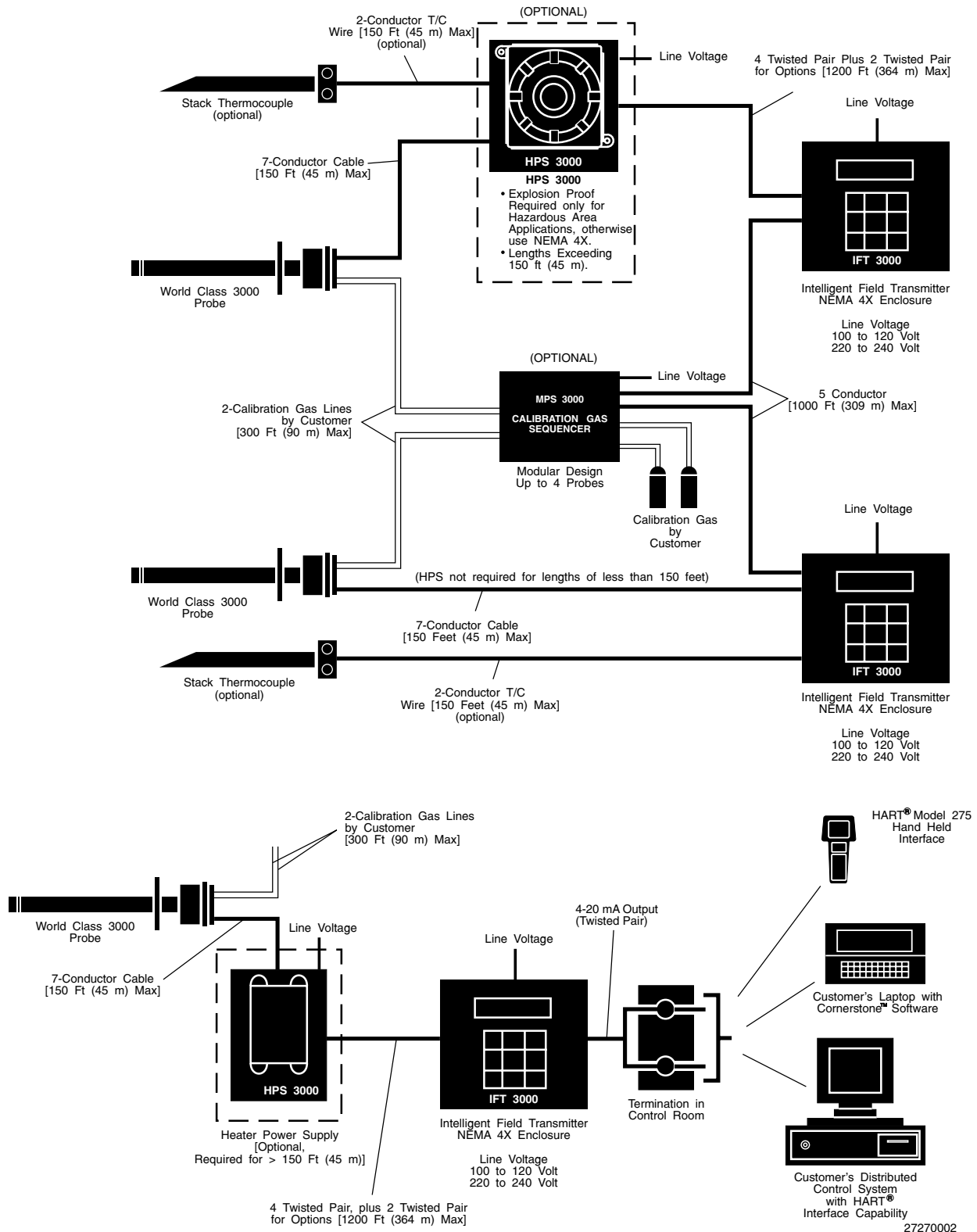

Figure 1-3. World Class 3000 Typical Application with Intelligent Field Transmitters

After selecting the probe mounting location, provision should be made for a platform where the probe can be easily serviced. The intelligent field transmitter (IFT) can be located up to 150 ft (45 m) cabling distance from the probe when used without optional heater power supply (HPS). When the system includes the optional HPS, the HPS can be located up to 150 ft (45 m) cabling distance from the probe and the IFT may be located up to 1200 ft (364 m) cabling distance from the HPS.

A source of instrument air is required at the probe for reference air use. Since the probe is equipped with an in-place calibration feature, provision should be made for con-

necting calibration gas tanks to the oxygen analyzer when the probe is to be calibrated.

If the calibration gas bottles will be permanently hooked up, a check valve is required next to the calibration fittings on the probe junction box. This is to prevent breathing of calibration gas line and subsequent flue gas condensation and corrosion. The check valve is in addition to the stop valve in the calibration gas kit or the solenoid valve in the multiprobe calibration gas sequencer units.

An optional Z-purge arrangement is available for applications where hazardous area classification may be required (See Application Data Bulletin AD 106-300B).

SECTION 2 INSTALLATION

2-1 OXYGEN ANALYZER (PROBE) INSTALLATION

WARNING

Before starting to install this equipment, read the "Safety instructions for wiring and installation of this apparatus" at the front of this Instruction Bulletin. Failure to follow the safety instructions could result in serious injury or death.

a. Selecting Location

1. The location of the probe in the stack or flue is most important for maximum accuracy in the oxygen analyzing process. The probe must be positioned so that the gas it measures is representative of the process. Best results are normally obtained if the probe is positioned near the center of the duct (40 to 60% insertion). A point too near the edge or wall of the duct may not provide a representative sample because of the possibility of gas stratification. In addition, the sensing point should be selected so that the process gas temperature falls within a range of 50° to 1300°F (10° to 704°C). Figure 2-1 provides mechanical installation references.
2. Check the flue or stack for holes and air leakage. The presence of this condition will substantially affect the accuracy of the oxygen reading. Therefore, either make necessary repairs or install the probe upstream of any leakage.
3. Ensure that the area is clear of obstructions internal and external that will interfere with installation. Allow adequate clearance for removal of probe (Figure 2-1).
4. If the probe is to be mounted outside, subject to rain and snow conditions, make sure the back of the probe (outside of the duct) is insulated to prevent the formation of flue gas condensate in the calibration gas lines.

CAUTION

Do not allow the temperature of the probe junction box to exceed 300°F (149°C) or damage to the unit may result. If the probe junction box temperature exceeds 300°F (149°C), the user must fabricate a heat shield or provide adequate cooling air to the probe junction box.

b. Mechanical Installation

1. Ensure that all components are available for installation of the probe. Ensure that the system cable is the required length. If equipped with the optional ceramic diffusor element, ensure that it is not damaged.
2. The probe may be installed intact as it is received. It is recommended that you disassemble the adapter plate for each installation.

NOTE

An abrasive shield is recommended for high velocity particulate in the flue stream (such as those in coal fired boilers, kilns, and recovery boilers). Vertical and horizontal brace clamps are provided for 9 ft and 12 ft (2.75 m and 3.66 m) probes to provide mechanical support of the probe. Refer to Figure 2-1, sheet 5.

3. Weld or bolt adapter plate (Figure 2-1) onto the duct.

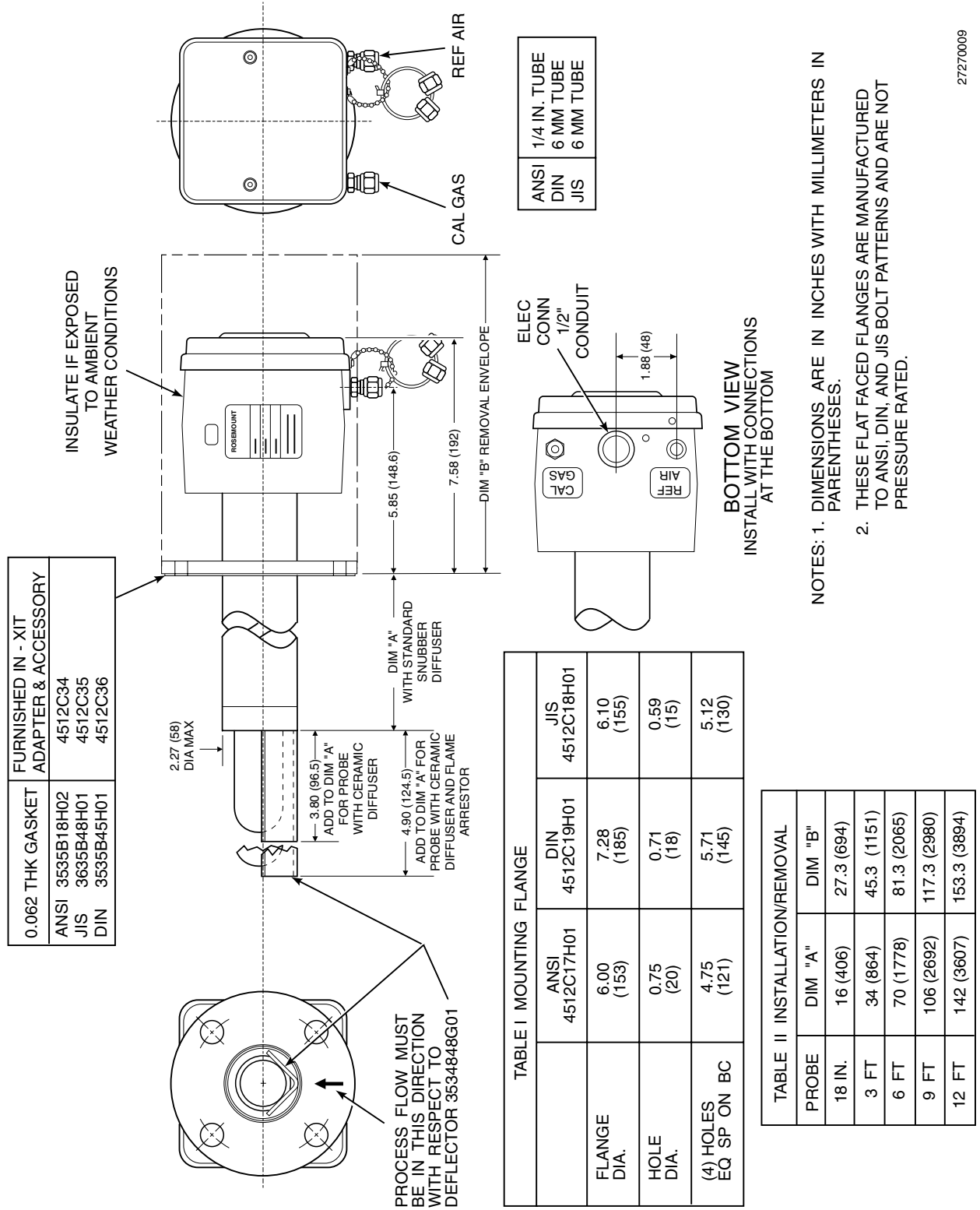

Figure 2-1. Probe Installation (Sheet 1 of 5)

TABLE IV. FLANGE SIZE

	FLANGE DIAMETER	(8) HOLES DIAMETER	BOLT CIRCLE
ANSI*	9.00 (153)	0.75	7.50
JIS*	9.25 (235)	0.75	7.48
DIN*	9.25 (235)	0.945	7.48

* FLANGES ARE MANUFACTURED TO ANSI, DIN, AND JIS BOLT PATTERNS AND ARE FLAT FACED. THESE FLANGES ARE NOT PRESSURE RATED.

TABLE III. REMOVAL/INSTALLATION NOMINAL MEASUREMENTS

	DIM "C"	DIM "D"	DIM "E"
3 FT	27 (686)	45.3 (1151)	31.1 (790)
6 FT	63 (1600)	81.3 (2065)	67.1 (1704)
9 FT	99 (2515)	117.3 (2980)	103.1 (2619)
12 FT	135 (3429)	153.3 (3894)	139.1 (3533)

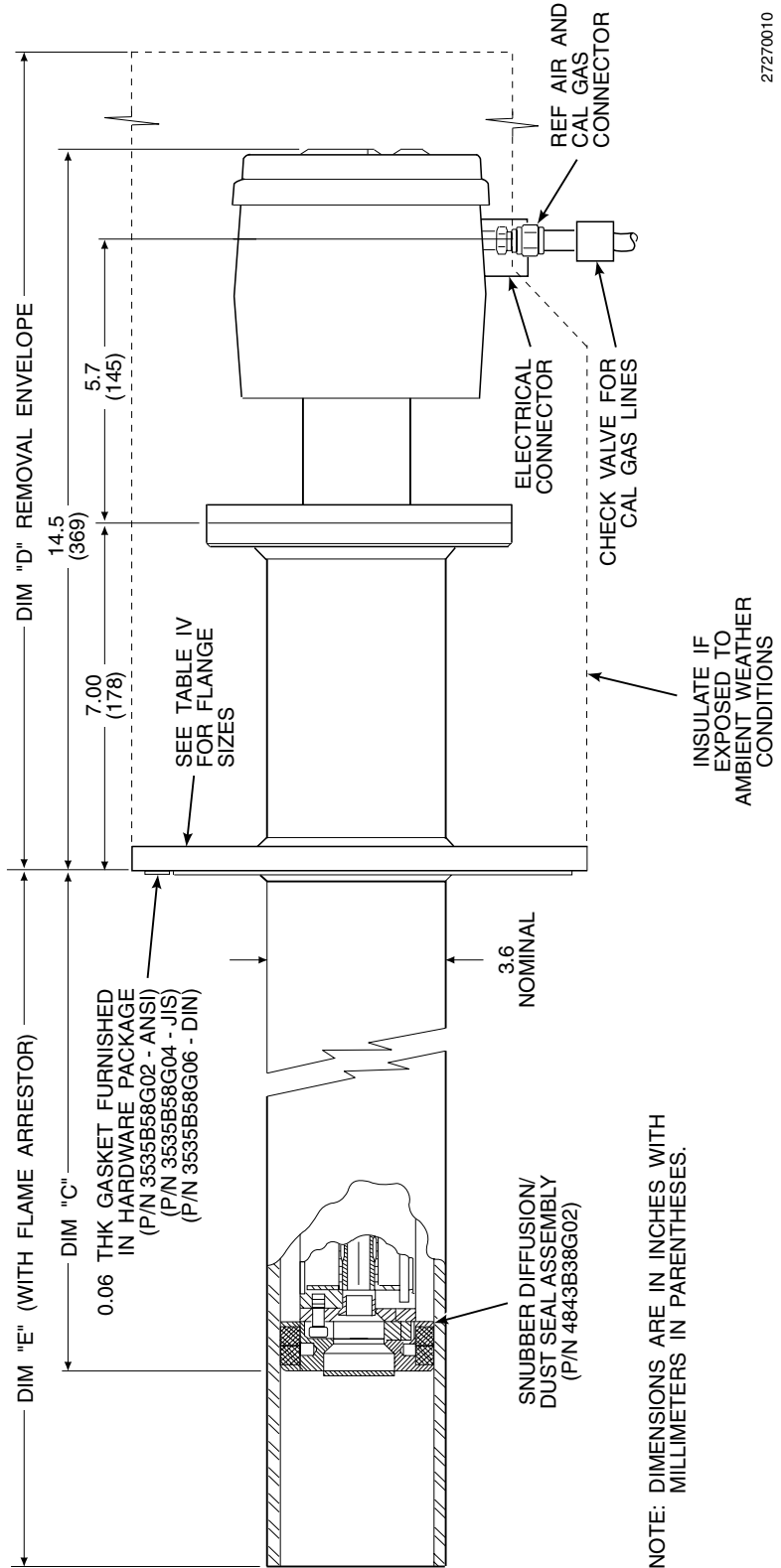

27270010

Figure 2-1. Probe Installation (Sheet 2 of 5)

ADAPTOR PLATE OUTLINE

TABLE V. ADAPTOR PLATE DIMENSIONS FOR PROBE		TABLE VI. ADAPTOR PLATE DIMENSIONS FOR ABRASIVE SHIELD				
DIMENSIONS IN. (mm)	ANSI (P/N 4512C34G01)	DIN (P/N 4512C36G01)	JIS (P/N 4512C35G01)	ANSI (P/N 3535B58G02)	DIN (P/N 3535B58G06)	JIS (P/N 3535B58G04)
"A"	6.00 (153)	7.5 (191)	6.50 (165)	9.00 (229)	9.25 (235)	9.25 (235)
"B" THREAD	0.625-11	(M-16 x 2)	(M-12 x 1.75)	4.75 (121)	3.94 (100)	4.92 (125)
"C" DIA	4.75 (121)	5.708 (145)	5.118 (130)	0.625-11	(M-16 x 2)	(M-20 x 2.5)
				7.50 (191)	7.48 (190)	7.894 (200)

NOTE: PART NUMBERS FOR ADAPTOR PLATES INCLUDE ATTACHING HARDWARE.

NOTE: PART NUMBERS FOR ADAPTOR PLATES INCLUDE ATTACHING HARDWARE.

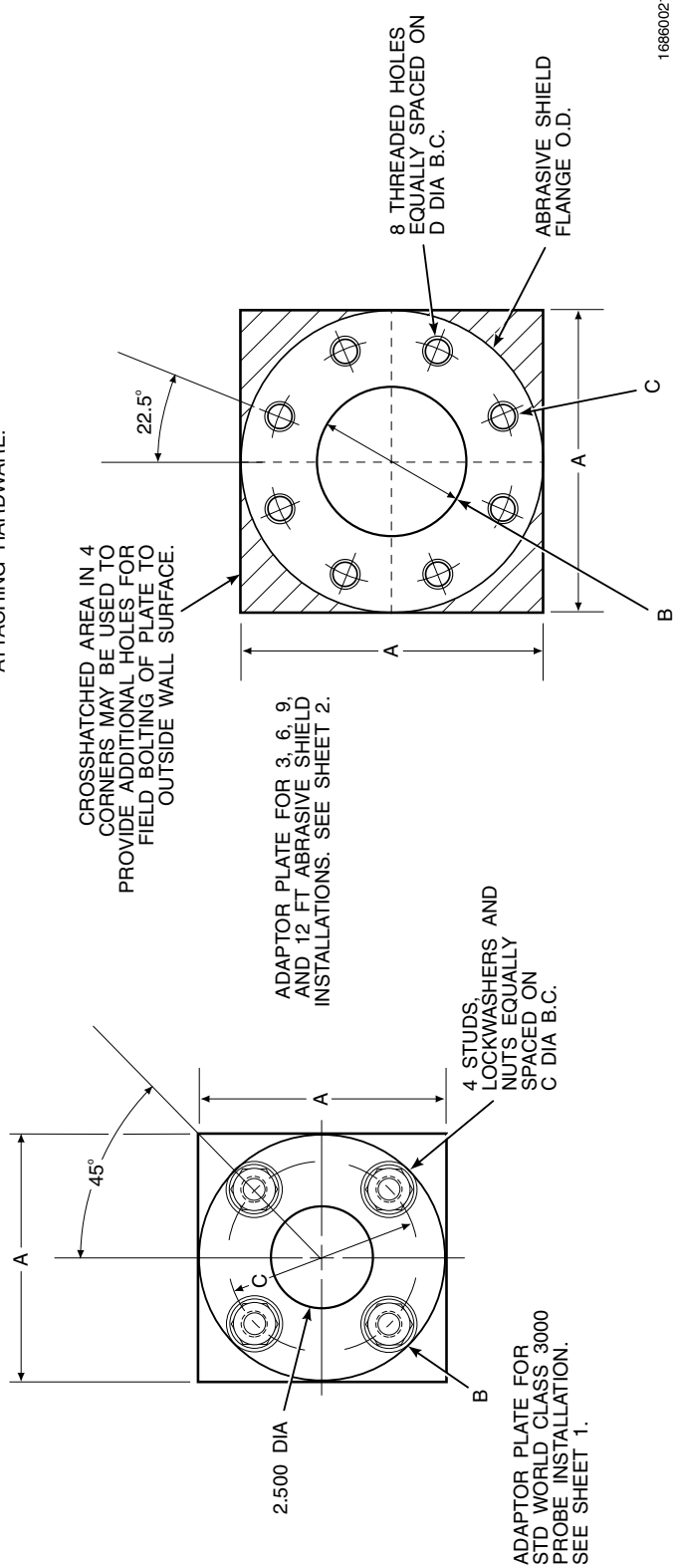

16660021

Figure 2-1. Probe Installation (Sheet 3 of 5)

INSTALLATION FOR METAL WALL STACK OR DUCT CONSTRUCTION

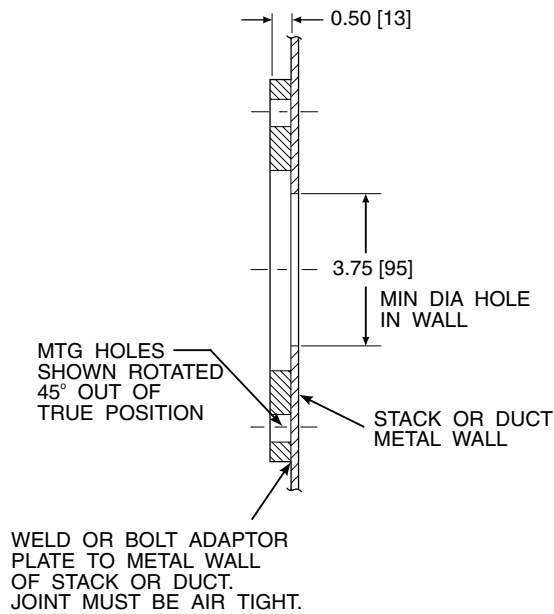

INSTALLATION FOR MASONRY WALL STACK CONSTRUCTION

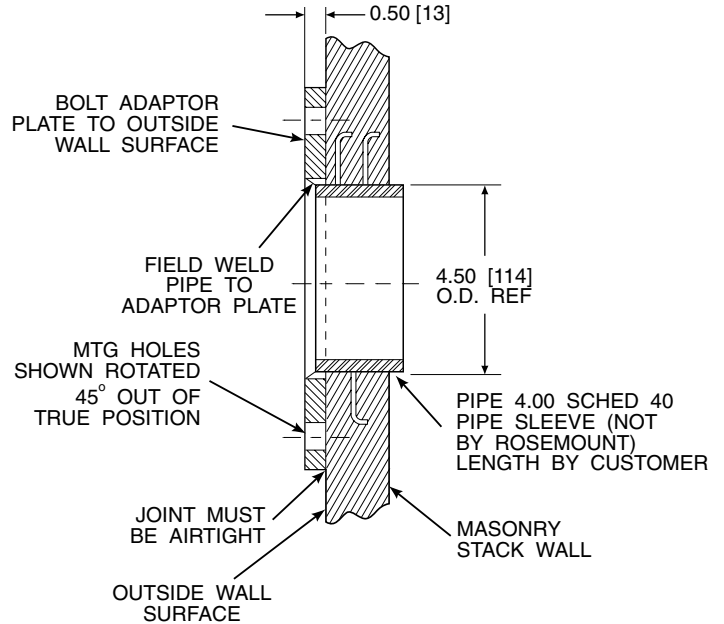

NOTE: ALL MASONRY STACK WORK AND JOINTS EXCEPT ADAPTOR PLATE NOT FURNISHED BY ROSEMOUNT.

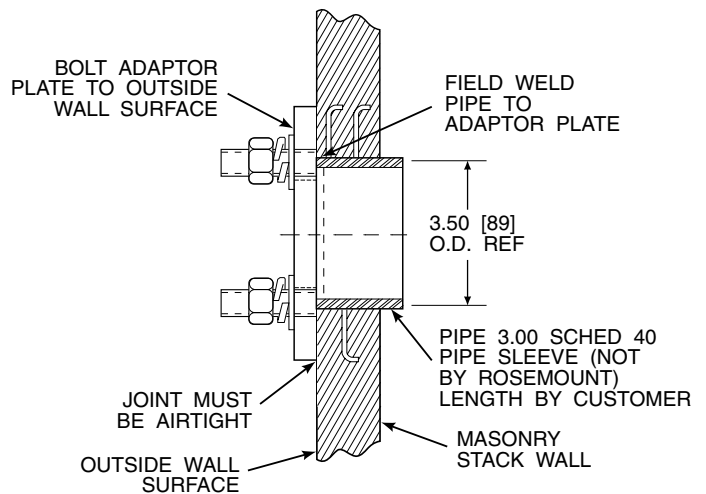
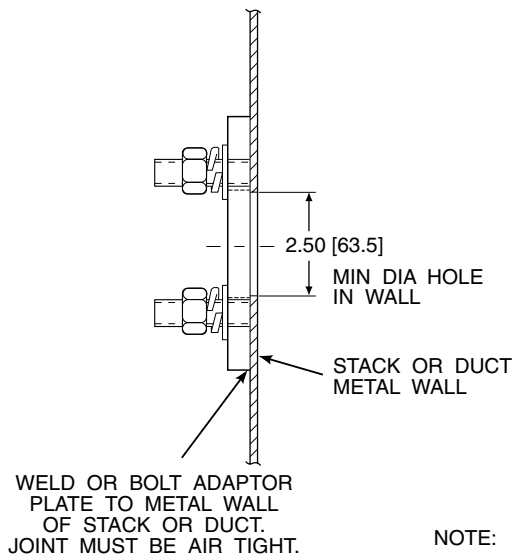

NOTE: DIMENSIONS IN INCHES WITH MILLIMETERS IN PARENTHESES.

624038

Figure 2-1. Probe Installation (Sheet 4 of 5)

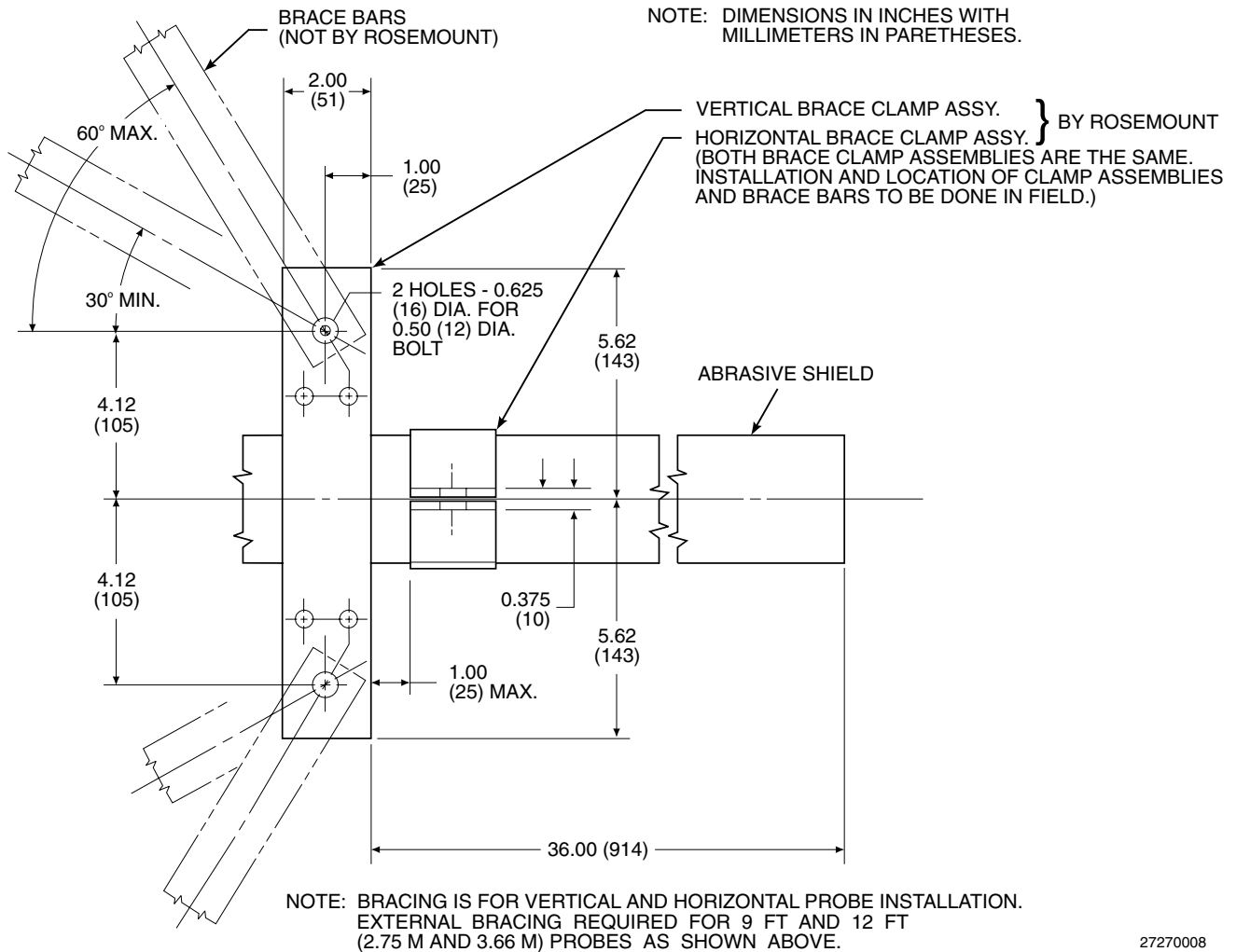

27270008

Figure 2-1. Probe Installation (Sheet 5 of 5)

4. If using the optional ceramic diffusor element, the vee deflector must be correctly oriented. Before inserting the probe, check the direction of flow of the gas in the duct. Orient the vee deflector on the probe so that the apex points upstream toward the flow (Figure 2-2). This may be done by loosening the setscrews, and rotating the vee deflector to the desired position. Retighten the setscrews.
5. In horizontal installations, the probe junction box should be oriented so that the system cable drops vertically from the probe junction box. In a vertical installation, the system cable can be oriented in any direction.
6. If the system has an abrasive shield, check the dust seal packings. The joints in the two packings must be staggered 180°. Also, make sure that the packings are in the hub grooves as the probe slides into the 15° forcing cone in the abrasive shield.

NOTE

If process temperatures will exceed 392°F (200°C), use anti-seize compound on stud threads to ease future removal of probe.

7. Insert probe through the opening in the mounting flange and bolt the unit to the flange. When probe lengths selected are 9 or 12 ft (2.75 or 3.66 m), special brackets are supplied to provide additional support for the probe inside the flue or stack. See Figure 2-1, sheet 5.

NOTE

Probe Installation

To maintain CE compliance, ensure there is a good connection between the chassis of the probe and earth.

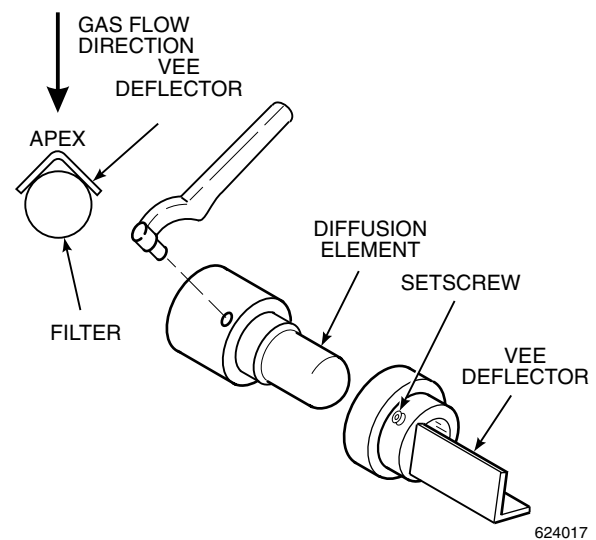

Figure 2-2. Orienting the Optional Vee Deflector

c. Reference Air Package

After the oxygen analyzing (probe) unit is installed, connect the reference air set to the probe junction box. The reference air set should be installed in accordance with Figure 2-3.

d. Service Required

1. Power input: 100, 115 or 220 Vac single phase, 50 to 60 Hz, 3 amp minimum. (See label.)
2. Compressed air: 10 psig (68.95 kPa) minimum, 225 psig (1551.38 kPa)

maximum at 2 scfh (56.6 L/hr) maximum; supplied by one of the following (less than 40 parts-per-million total hydrocarbons). Regulator outlet pressure should be set at 5 psi (35 kPa).

- (a) Instrument air - clean, dry.
- (b) Bottled standard air with step-down regulator.
- (c) Bottled compressed gas mixture (20.95% oxygen in nitrogen).
- (d) Other equivalent clean, dry, oil-free air supply.

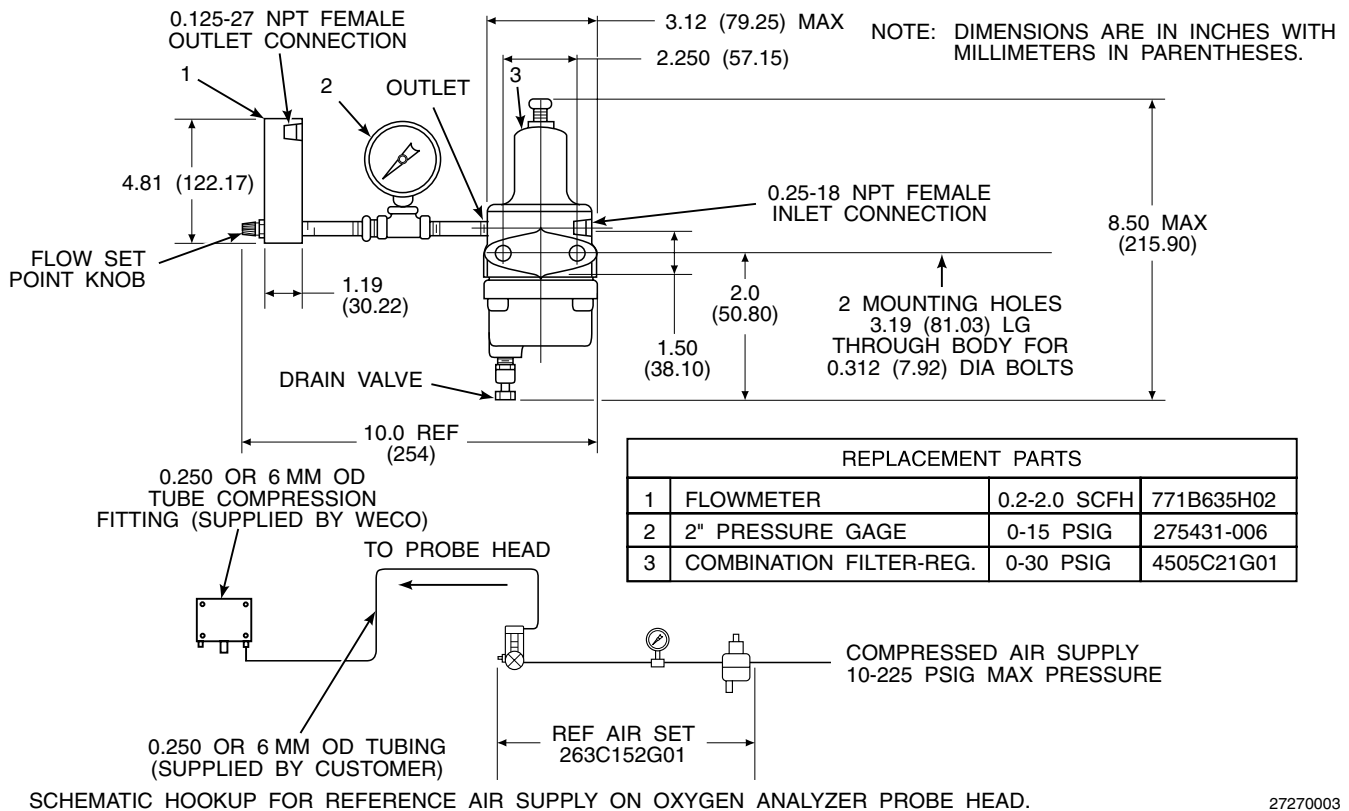

Figure 2-3. Air Set, Plant Air Connection

2-2 INTELLIGENT FIELD TRANSMITTER (IFT) INSTALLATION

a. Mechanical Installation

The outline drawing of the IFT module in Figure 2-4 shows mounting centers and clearances. The NEMA 4X enclosure is designed to be mounted on a wall or bulk-head. The IFT should be installed no more than 1200 feet (364 m) from the optional HPS or 150 feet (45 m) from the probe if HPS is not installed in the system.

b. Electrical Connections

WARNING

To meet the Safety Requirements of IEC 1010 (EC requirement), and ensure safe operation of this equipment, connection to the main electrical power supply must be made through a circuit breaker (min 10A) which will disconnect all current carrying conductors during a fault situation. This circuit breaker should also include a mechanically operated isolating switch. If not, then another external means of disconnecting the supply from the equipment should be located close by. Circuit breakers or switches must comply with a recognized standard such as IEC 947.

NOTE

Refer to Figure 2-7 for fuse locations and specifications.

1. The IFT can be configured for 100, 120, 220, or 240 line voltages. For 120 Vac usage, install JM8, JM7, and JM1 on the power supply board. For 220 Vac usage, install jumpers JM6, JM5, JM2 (refer to Figure 2-5 and Figure 2-7).
2. For installations where the cable run is less than 150 feet (45 m), the IFT can

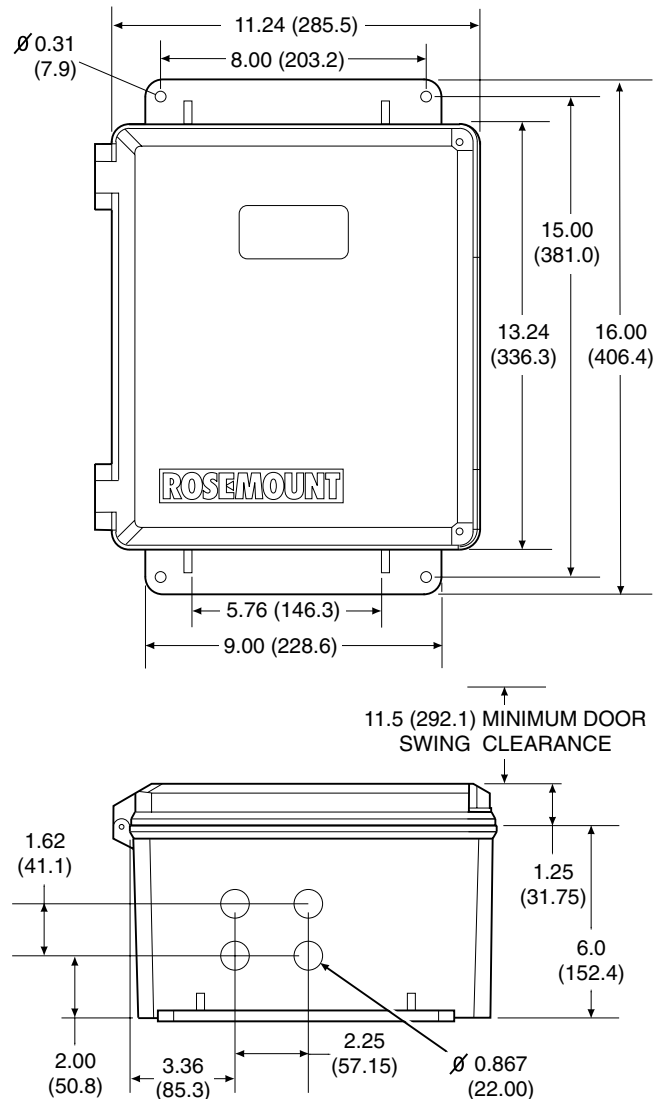

NOTE: DESIGN DIMENSIONS ARE IN INCHES WITH MILLIMETERS IN PARENTHESES.

21190002

Figure 2-4. Outline of Intelligent Field Transmitter

be configured to connect directly to a probe. An optional HPS is available for cable runs over 150 feet (45 m). The electrical connections for a non-HPS equipped system should be made as described in the electrical installation diagram, Figure 2-8. Refer to Figure 2-14 for connections for an HPS equipped system.

CAUTION

Do not install jumper JM6 on the microprocessor board, or JM1 on the interconnect board, if an HPS is installed in the system. This will result in system failure.

3. The IFT must have JM6 on the microprocessor board (Figure 2-9 and Figure 2-10) and JM1 on the interconnect board (Figure 2-11 and Figure 2-12) installed if an HPS is not installed in the system.
4. If an MPS is not used in the system, wire jumper between CAL RET and NO GAS must be installed on the interconnect board. Remove wire jumper if MPS is installed in the system. Refer to Figure 2-8, note 6.
5. The power cable should comply with the safety regulations in the user's country and should not be smaller than 16 gauge, 3 amp.
6. Before supplying power to the IFT, verify that the jumpers have been properly set in the IFT (Figure 2-5, Figure 2-9, and Figure 2-11).
7. Terminal strip J5 on the power supply board is used for supplying the IFT with power. Terminal strip J6 on the power supply board is used to supply the probe heater with power if an HPS is not used (Figure 2-7).



JUMPER CONFIGURATION

ALWAYS DISCONNECT LINE VOLTAGE FROM INTELLIGENT FIELD TRANSMITTER BEFORE CHANGING JUMPERS.

LINE VOLTAGE SELECTION	JUMPER (INSTALL)	PROBE HEATER VOLTAGE SELECTION	JUMPER (INSTALL)
100 V.A.C.	JM3, JM7, JM2	WORLD CLASS PROBE (44V)	JM10
120 V.A.C.	JM8, JM7, JM1	218 PROBE (115V)	JM9
220 V.A.C.	JM6, JM5, JM2	WORLD CLASS "DIRECT REPLACEMENT" PROBE (115V)	JM9
240 V.A.C.	JM6, JM5, JM1		

21190012

CAUTION

If incorrect heater voltage is selected, damage to the probe may occur. For HPS voltage selection jumper, refer to Figure 2-15. Always update the relevant labeling to reflect the set voltage.

Figure 2-5. Power Supply Board Jumper Configuration

NOTE**General Wiring Recommendations**

To maintain CE compliance and ensure proper EMC performance, all signal wires to the Interconnect Board, with the exception of the probe cable, should be looped through the ferrite beads provided as shown in Figure 2-6 (P/N 1L04253H01). Signal wires may be grouped together and looped through before exiting the enclosure. Ferrite beads should be placed as close as possible to the exit point. Ferrite beads are provided for European Common Market applications only.

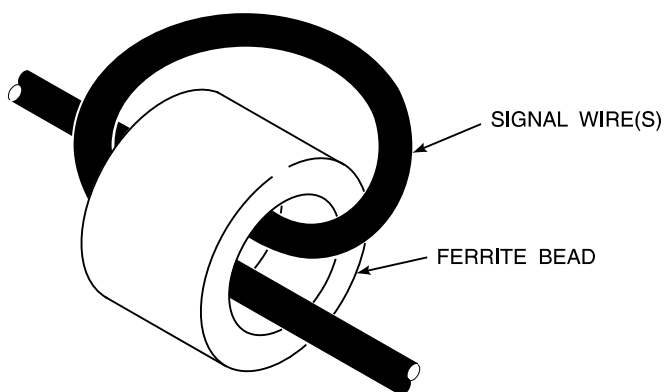

19280016

Figure 2-6. Signal Wire Routing

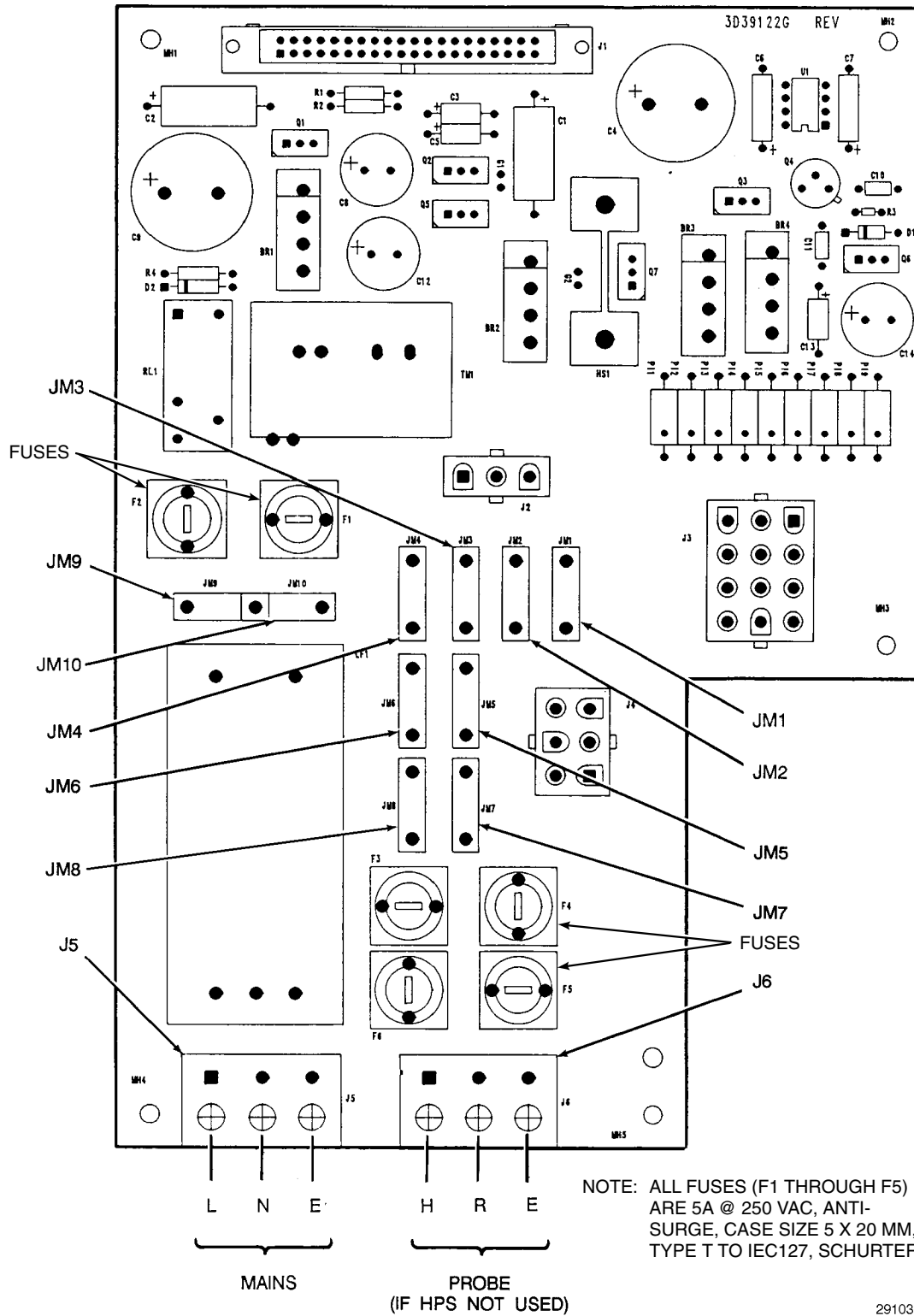

Figure 2-7. IFT Power Supply Board Jumpers

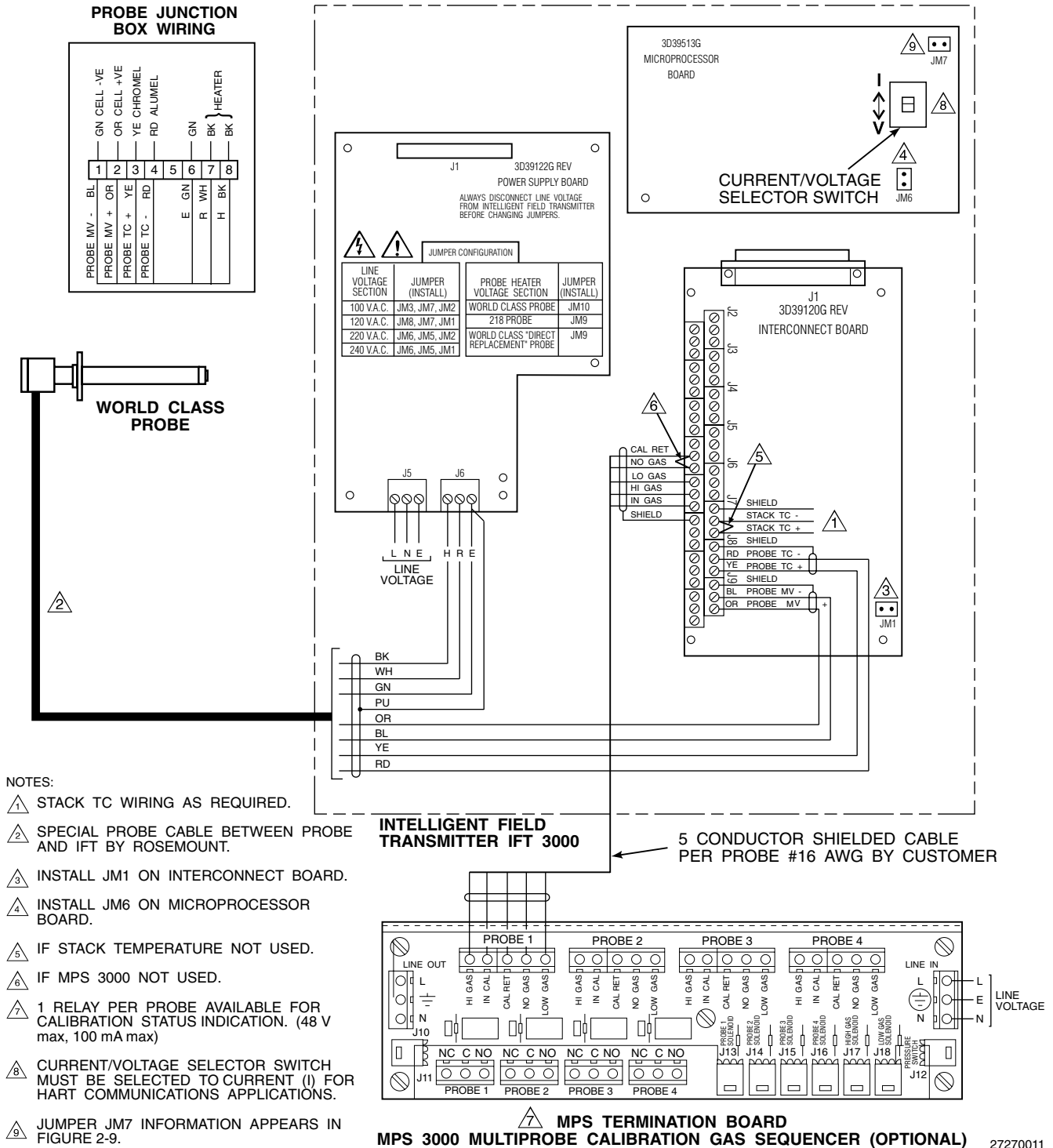

Figure 2-8. Wiring Layout for IFT Systems without HPS

OUTPUT	JUMPER
HPS	Remove JM6
Probe (No HPS)	Install JM6

ANALOG OUTPUT (Condition during microcontroller failure)	Jumper
Output = zero	Install JM7
Output = maximum	Remove JM7

(See Figure 2-10 for jumper locations.)

Figure 2-9. Microprocessor Board Jumper Configuration

c. Analog Output and Relay Output Connections

1. The microprocessor board has a selector for voltage or current operations. Figure 2-10 shows switch orientation. In voltage mode, output is 0-10 V. In the current mode, the output can be configured from the SETUP menu to be 0-20 mA or 4-20 mA.
2. The analog output and relay outputs are programmed by the user as needed. The analog output is typically sent to recording equipment such as

chart recorders. Relay outputs are typically sent to annunciators.

3. Relays K1 and K2 are user configurable from the probe SETUP sub-menu (Table 5-5). Typically these are used to indicate O₂ values above or below specified tolerances. OK relay is energized when unit is functioning properly.
4. All wiring must conform to local and national codes.
5. Connect the analog output and relay outputs as shown in Figure 2-12.

2-3 HEATER POWER SUPPLY INSTALLATION

a. Mechanical Installation

The outline drawing of the heater power supply enclosure in Figure 2-13 shows mounting centers and clearances. The NEMA 4X enclosure is designed to be mounted on a wall or bulkhead. The heater power supply should be installed no further than 150 feet (45 m) from the probe. The heater power supply must be located in a location free from significant ambient temperature changes and electrical noise. Ambient temperature must be between -20° and 140°F (-30° and 60°C).

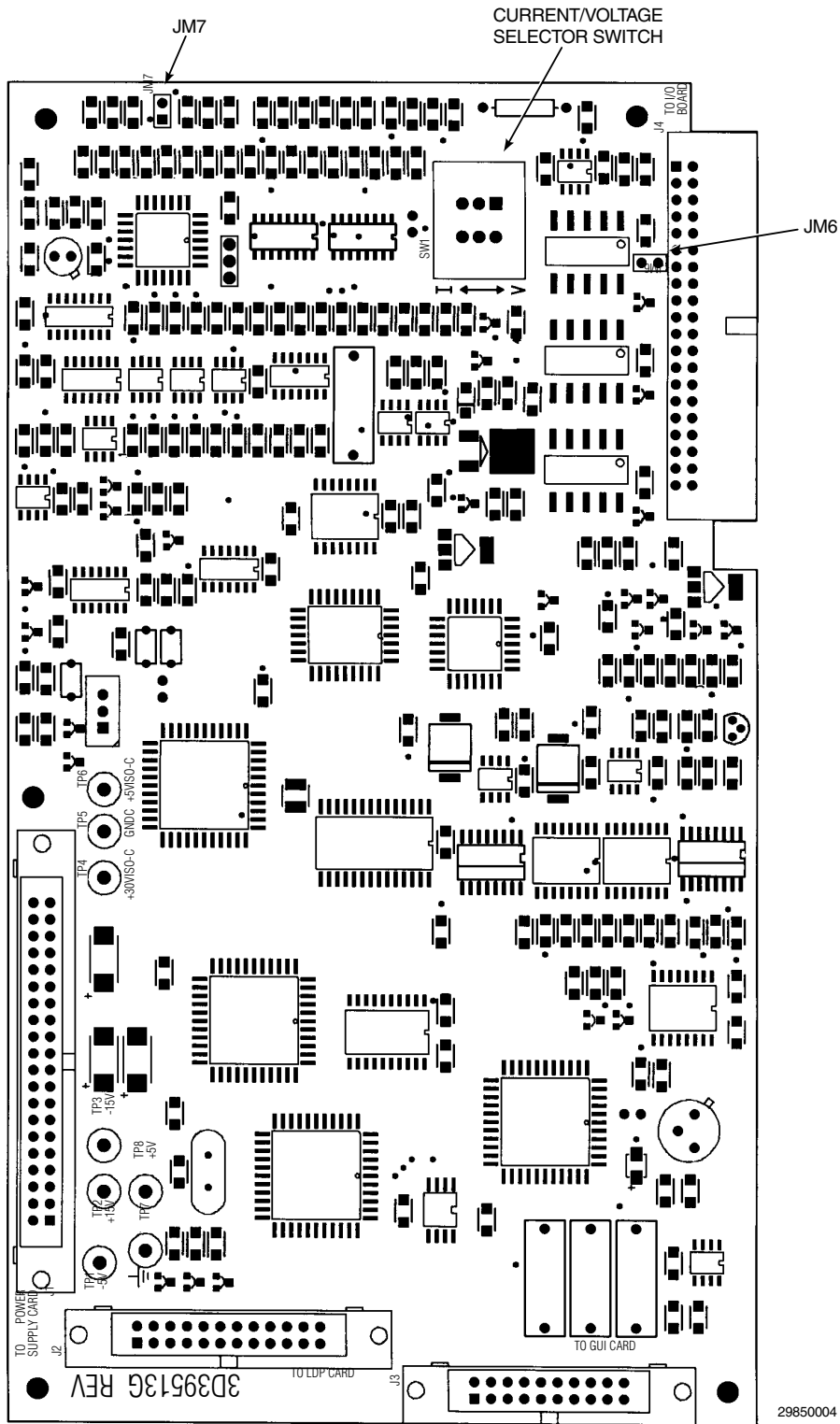

Figure 2-10. IFT Microprocessor Board

OUTPUT	JUMPER
HPS	Remove JM1
Probe (No HPS)	Install JM1

Figure 2-11. Interconnect Board Jumper Configuration

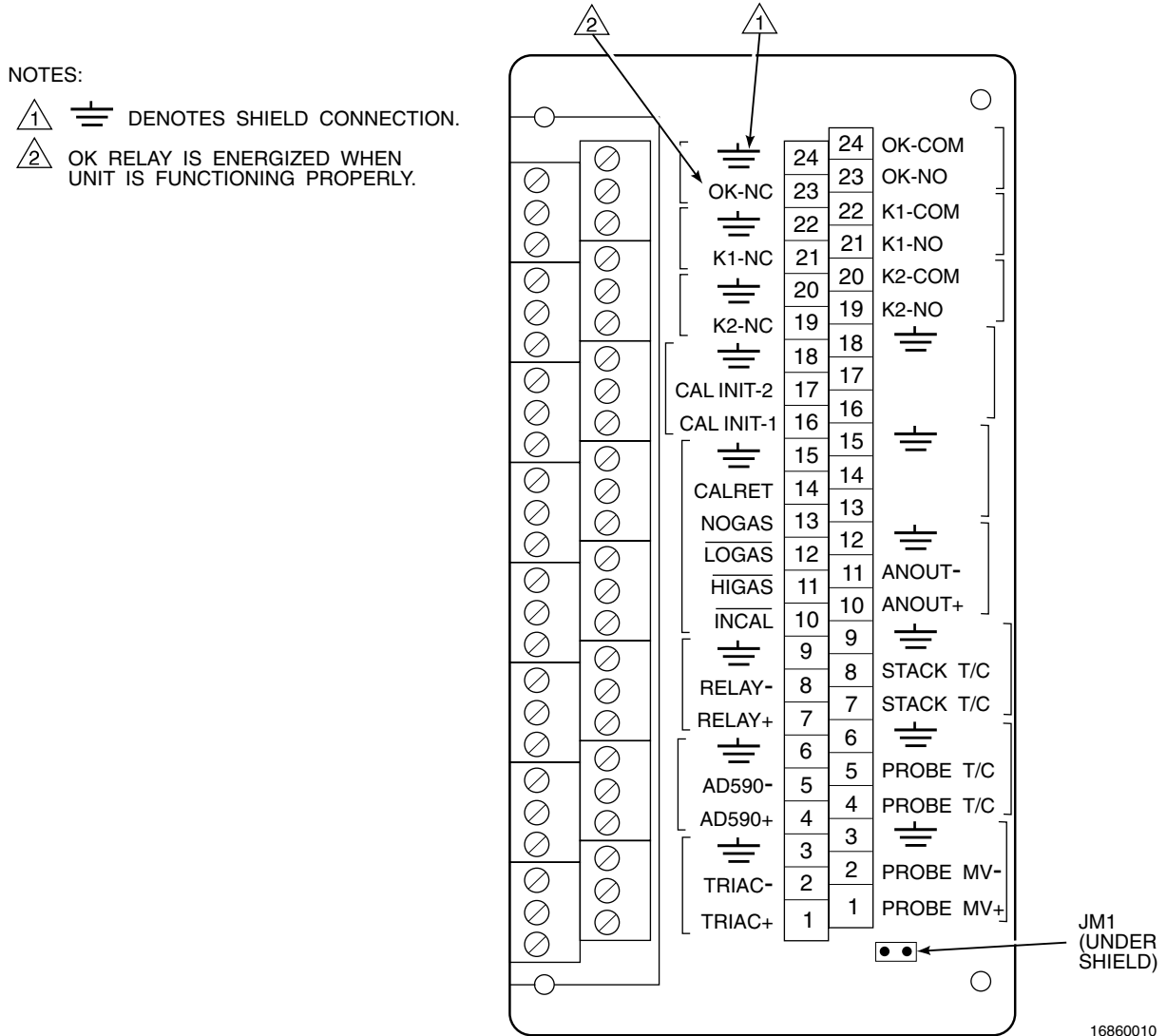

Figure 2-12. IFT Interconnect Board Output Connections

NOTE: DIMENSIONS IN INCHES
WITH MILLIMETERS IN PARENTHESES.

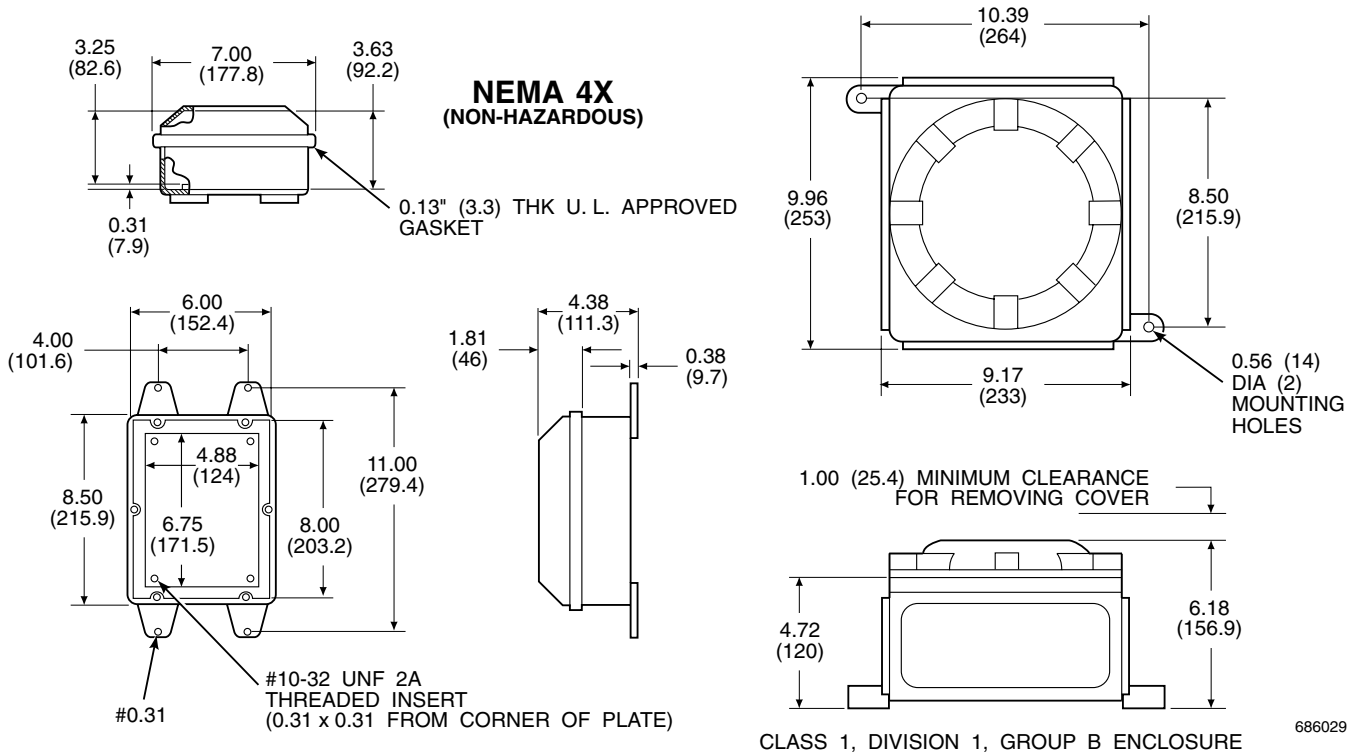

Figure 2-13. Outline of Heater Power Supply

b. Electrical Connections

1. Electrical connections should be made as described in the electrical installation diagram, Figure 2-14. The wiring terminals are divided into two layers; the bottom (FROM PROBE) terminals should be connected first, the top (FROM ELECTRONICS) terminals should be connected last (Figure 2-15). Each terminal strip has a protective cover which must be removed when making connections. To remove the terminal covers, remove two slotted screws holding cover in place. Always reinstall terminal covers after making connections. All wiring must conform to local and national codes.

2. Power Input: 120, 220 or 240 Vac. For 120 Vac usage, install jumpers JM4 and JM1. For 220 or 240 Vac usage, install jumper JM5 (see label, Figure 2-16).

NOTE

For 100 Vac usage, the heater power supply is factory-supplied with a different transformer. When using the HPS with 100 Vac transformer, install jumpers JM1 and JM4.

3. The power cable should comply with safety regulations in the user's country and should not be smaller than 16 gauge, 3 amp.

NOTE

Refer to Figure 2-17 for fuse locations and specifications.

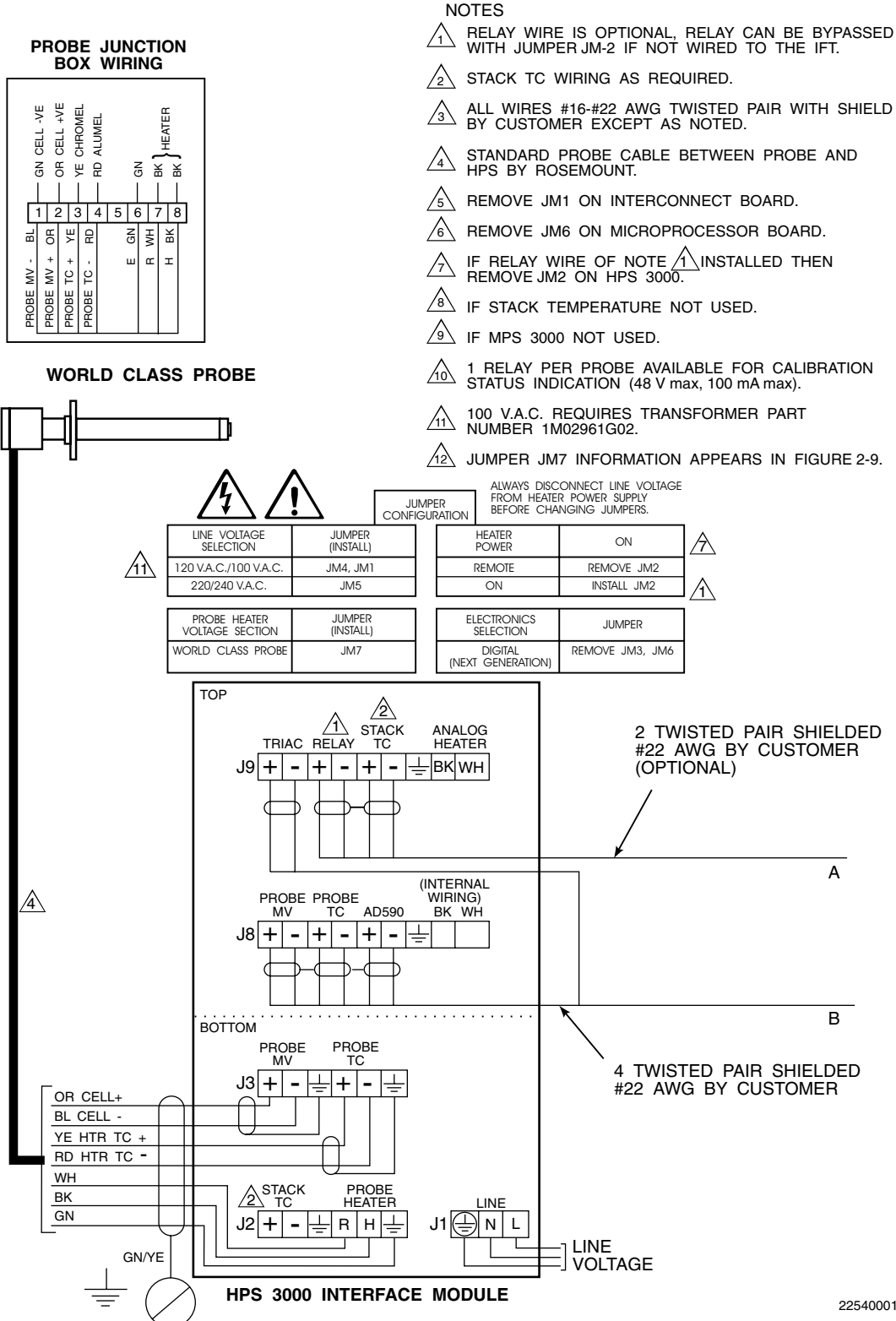

Figure 2-14. Wiring Layout for Complete IFT 3000 System with HPS (Sheet 1of 2)

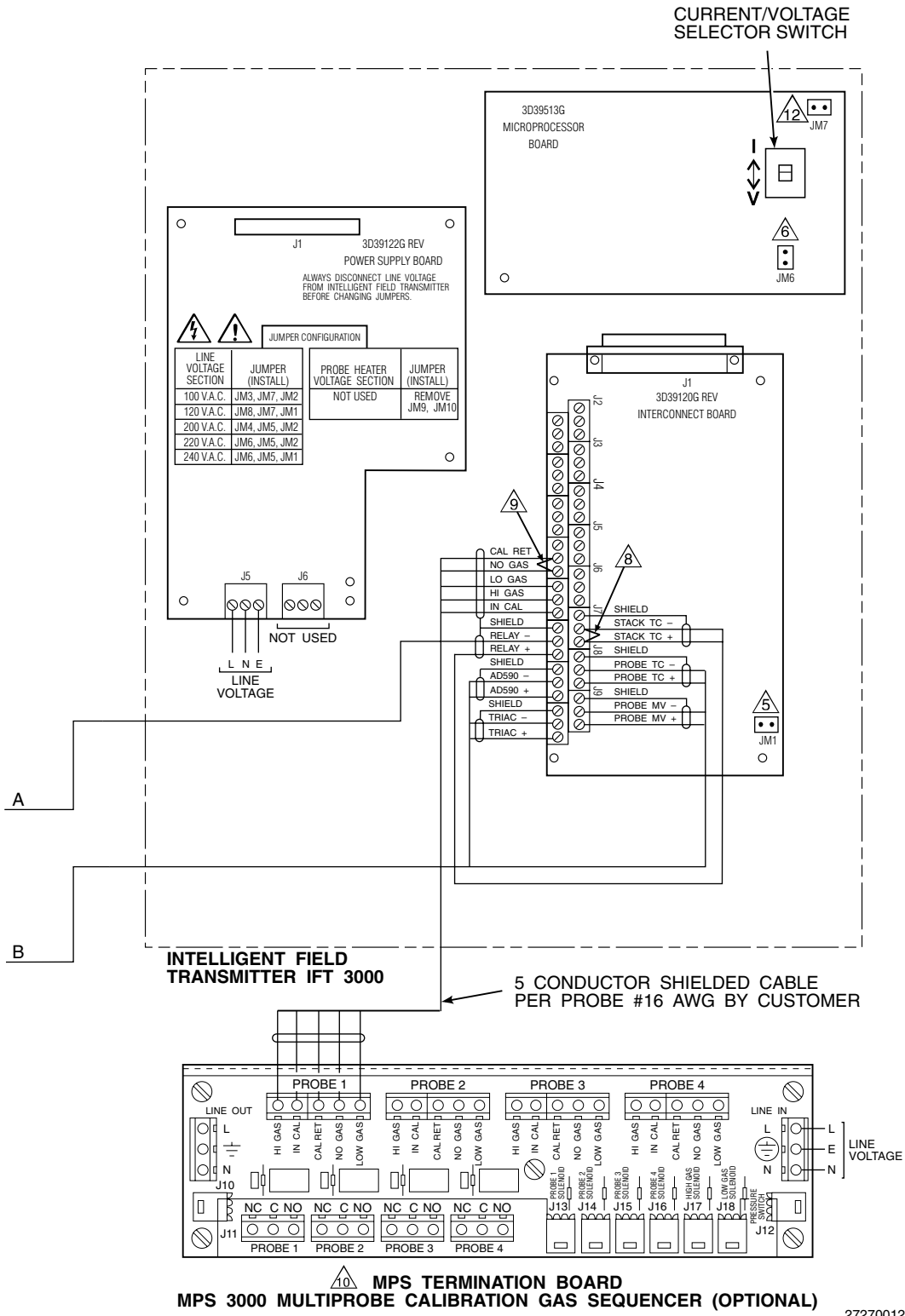

Figure 2-14. Wiring Layout for Complete IFT 3000 System with HPS (Sheet 2 of 2)

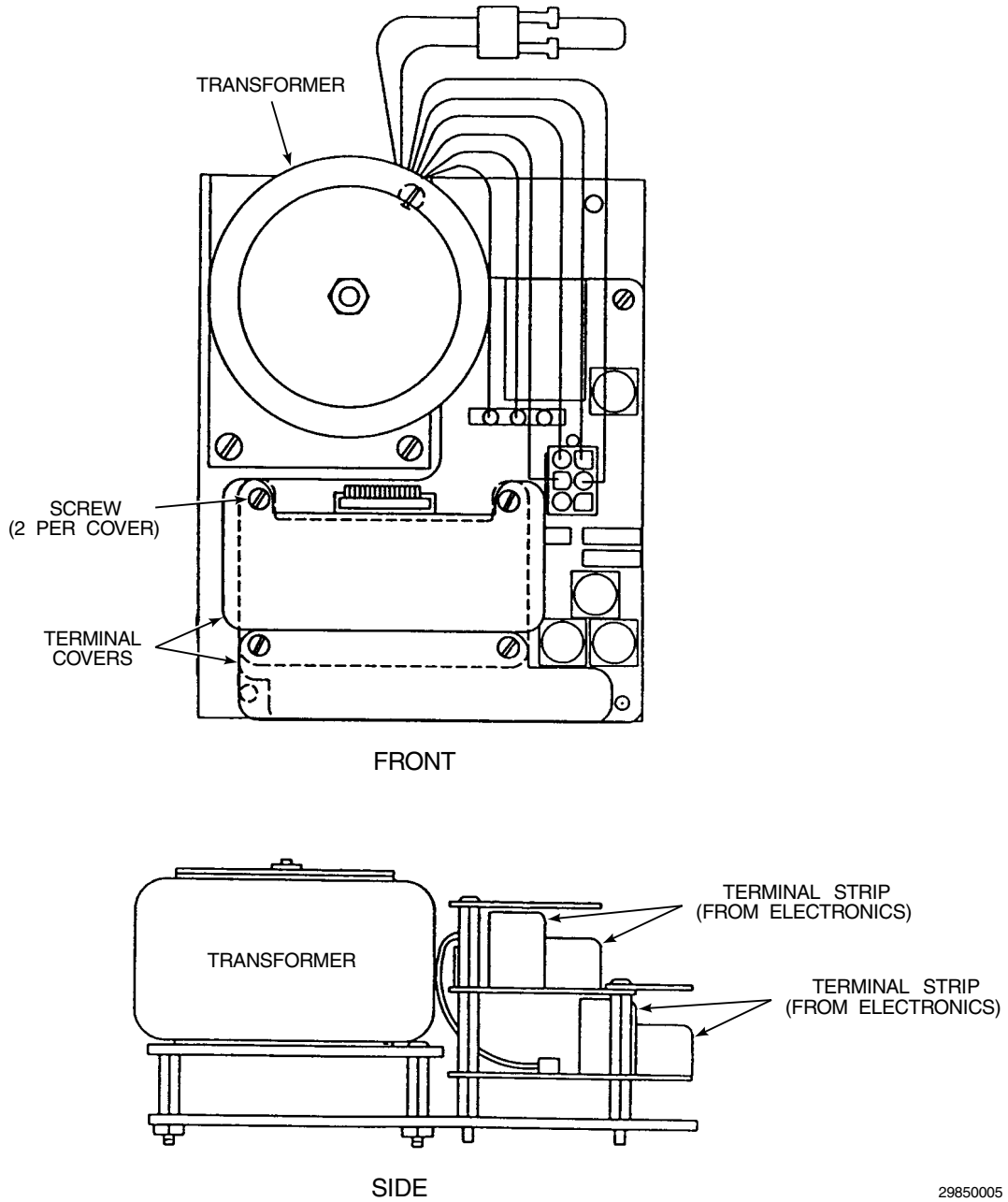
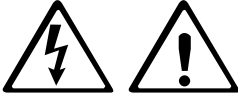

Figure 2-15. Heater Power Supply Wiring Connections

		JUMPER CONFIGURATIONS		ALWAYS DISCONNECT LINE VOLTAGE FROM HEATER POWER SUPPLY AND ANALOG ELECTRONICS (IF USED) BEFORE CHANGING JUMPERS.	
				HEATER POWER	JUMPER
1	LINE VOLTAGE SELECTION	JUMPER (INSTALL)	REMOTE	REMOVE JM2	
	100/120 V.A.C.	JM4, JM1	ON	*INSTALL JM2	
2	PROBE HEATER VOLTAGE SELECTION	JUMPER (INSTALL)	ELECTRONICS SELECTION	JUMPER	
	220/240 V.A.C.	JM5	*ANALOG (EXISTING)	INSTALL JM3, JM6	
	WORLD CLASS PROBE (44V)	JM7	DIGITAL (NEXT GENERATION)	REMOVE JM3, JM6	
	218 PROBE (115V)	JM8			

NOTES:

1 100 V.A.C. OPERATION REQUIRES TRANSFORMER PART NUMBER 1M02961G02.

2 REFER TO TABLE 3-5 FOR PROPER SET POINT SELECTION.

0310122

Figure 2-16. Jumper Selection Label

NOTE

Before supplying power to the heater power supply, verify that jumpers JM3, JM6 are removed and JM7 is installed. If relay wire (Figure 2-14, note 1) is installed, JM2 must be removed from HPS Mother Board (Figure 2-17).

- Before supplying power to the heater power supply, verify that the jumpers on the mother board, Figure 2-17, are properly configured. Jumpers JM3 and JM6 should be removed and JM7 should be installed.

Additionally, make sure that the proper jumper for your line voltage is installed, Figure 2-16. If relay wire (Figure 2-14, note 1) is not installed, JM 2 should be installed on the HPS Mother Board (Figure 2-17).

NOTE

Refer to Figure 2-9 and Figure 2-11 for proper IFT jumper configuration. IFT microprocessor and interconnect board jumper configurations must be set correctly in order for HPS to work properly.

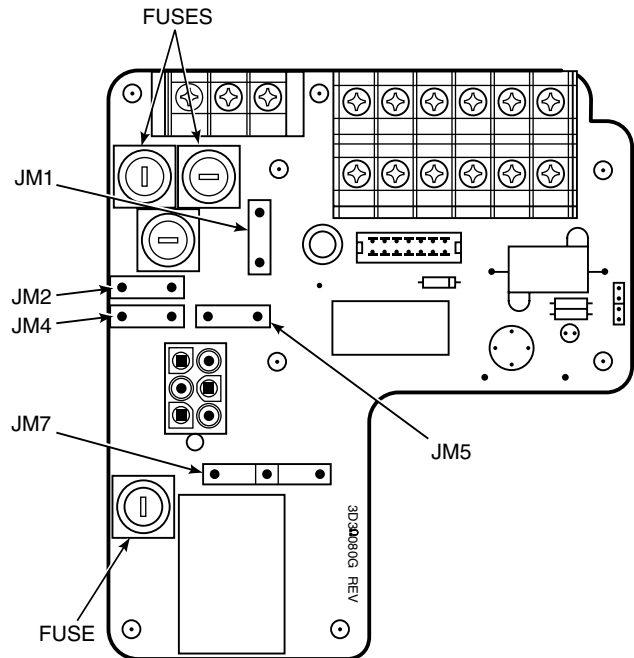

NOTE: ALL FUSES ARE 5A @ 250 VAC, ANTI-SURGE, CASE SIZE 5 X 20 MM, TYPE T TO IEC127, SCHURTER.

29850001

Figure 2-17. Jumpers on HPS Mother Board

2-4 MULTIPROBE CALIBRATION GAS SEQUENCER INSTALLATION

a. Mechanical Installation

The outline drawing of the MPS module in Figure 2-18 shows mounting centers and clearances. The box is designed to be mounted on a wall or bulkhead. The MPS module should be installed no further than 300 feet (91 m) piping distance from the probe, and no more than 1000 feet (303 m) cabling distance from the IFT. Install the MPS module in a location where the ambient temperature is between -20° and 160°F (-30° and 71°C).

b. Gas Connections

Figure 2-19 shows the bottom of the MPS where the gas connections are made. 1/4 inch threaded fittings are used.

1. Connect the reference air supply to INSTR. AIR IN. The air pressure regulator valve is set at the factory to 20 psi (138 kPa). If the reference air pressure should need readjustment, turn the knob on the top of the valve until the desired pressure is obtained.
2. Connect the high O₂ calibration gas to HIGH GAS. The calibration gas pressure should be set at 20 psi (138 kPa).

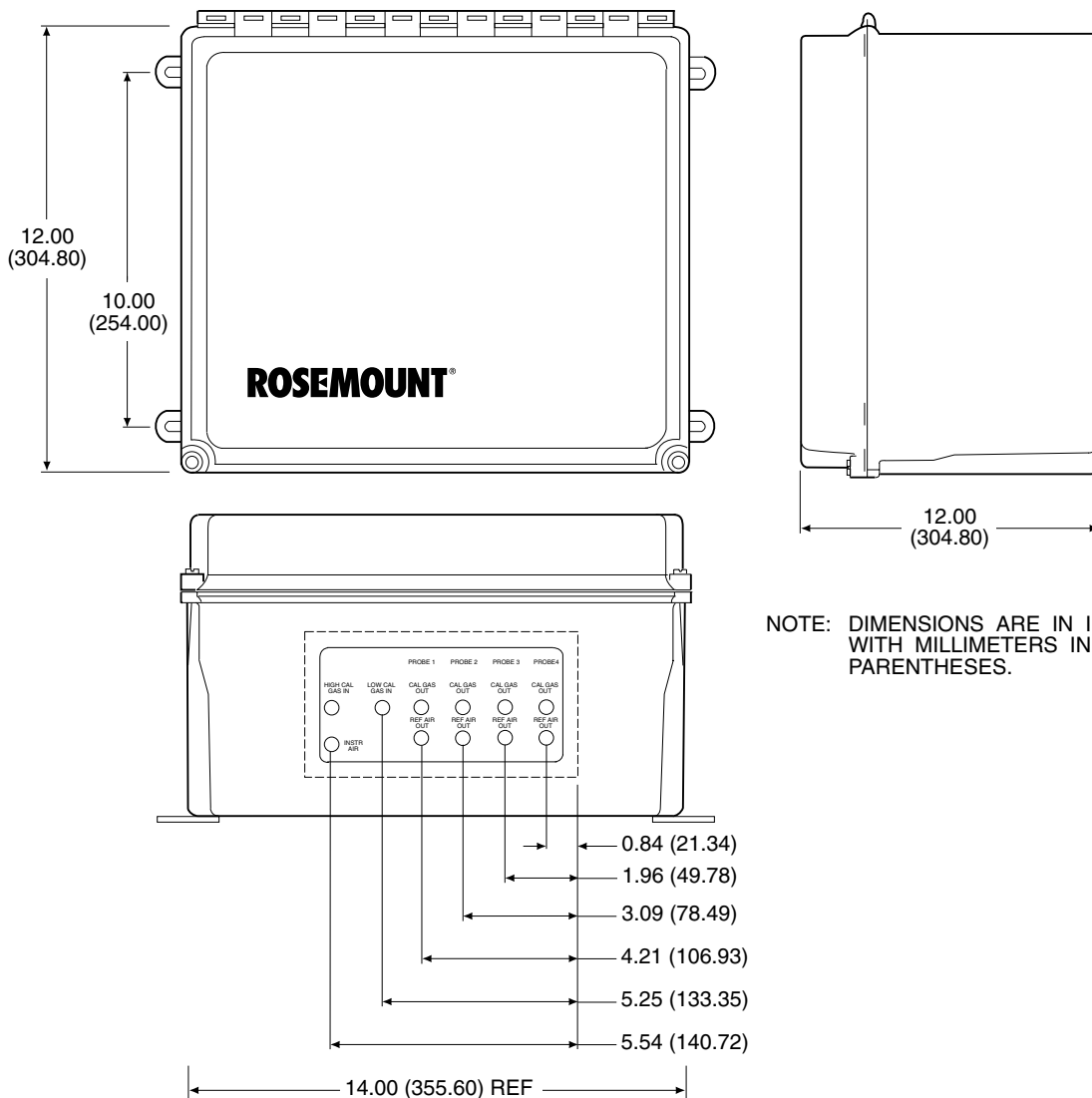

NOTE: DIMENSIONS ARE IN INCHES WITH MILLIMETERS IN PARENTHESES.

Figure 2-18. MPS Module

27270013

3. Connect the low O₂ calibration gas to LOW GAS. The calibration gas pressure should be set at 20 psi (138 kPa).
4. Connect the REF AIR OUT to the reference air fitting on the probe junction box.
5. Connect the CAL GAS OUT to the calibration gas fitting on the probe junction box.
6. If the MPS is configured for multiple probes (up to four), repeat steps 4 and 5 for each additional probe.

CAUTION

A check valve is required for each probe connected to an MPS to prevent condensation of flue gas in the calibration gas lines. The check valve must be located between the calibration fitting and the gas line.

c. Electrical Connections

Electrical connections should be made as described in the electrical installation diagram, Figure 2-20. All wiring must conform to local and national codes. The electrical connections will exist only between the electronics package and the MPS to enable automatic and semiautomatic calibration. If

more than one probe system is being used, the additional probes and electric packages would be wired similar to the first probe.

NOTE

Refer to Figure 2-20 for fuse locations and specifications.

1. Run the line voltage through the bulk-head fitting on the bottom of the MPS where marked LINE IN, Figure 2-19. Connect the line voltage as shown in Figure 2-20 to the LINE IN terminal on the MPS termination board located inside the unit. Tighten the cord grips to provide strain relief.
2. The MPS can accommodate up to four probes. The terminal strips on the MPS termination board are marked PROBE 1, PROBE 2, PROBE 3, and PROBE 4. Select PROBE 1 if this is the first probe and electronic package installed on the MPS.
3. Make the connections from the MPS to the IFT as shown in Figure 2-20. Run wires from the MPS Termination Board inside the unit through the bulkhead fitting on the bottom of the unit where marked SIGNAL IN, Figure 2-19. After the connections are made, tighten the cord grips to provide strain relief.

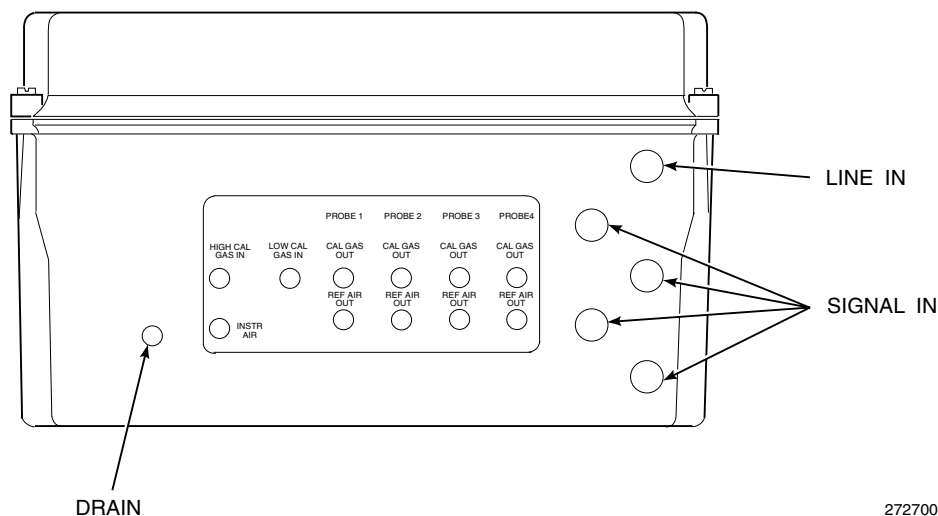

27270014

Figure 2-19. MPS Gas Connections

NOTE: FUSES FOR 115 VOLT MPS UNIT ARE FAST ACTING, 1A @ 250 VAC, SIZE: 1/4 IN. DIA X 1-1/4 IN. LG., GLASS BODY, NON-TIME DELAY, BUSSMAN PART NO. BK/AGC-1 (ROSEMOUNT APRT NO. 138799-004).

FUSES FOR 220 VOLT MPS UNIT ARE FAST ACTING, 0.5 A @ 250 VAC, SIZE 1/4 IN. DIA. X 1-1/4 IN. LG., GLASS BODY, NON-TIME DELAY, BUSSMAN PART NO. BK/AGC-1/2 (ROSEMOUNT PART NO. 138799-014).

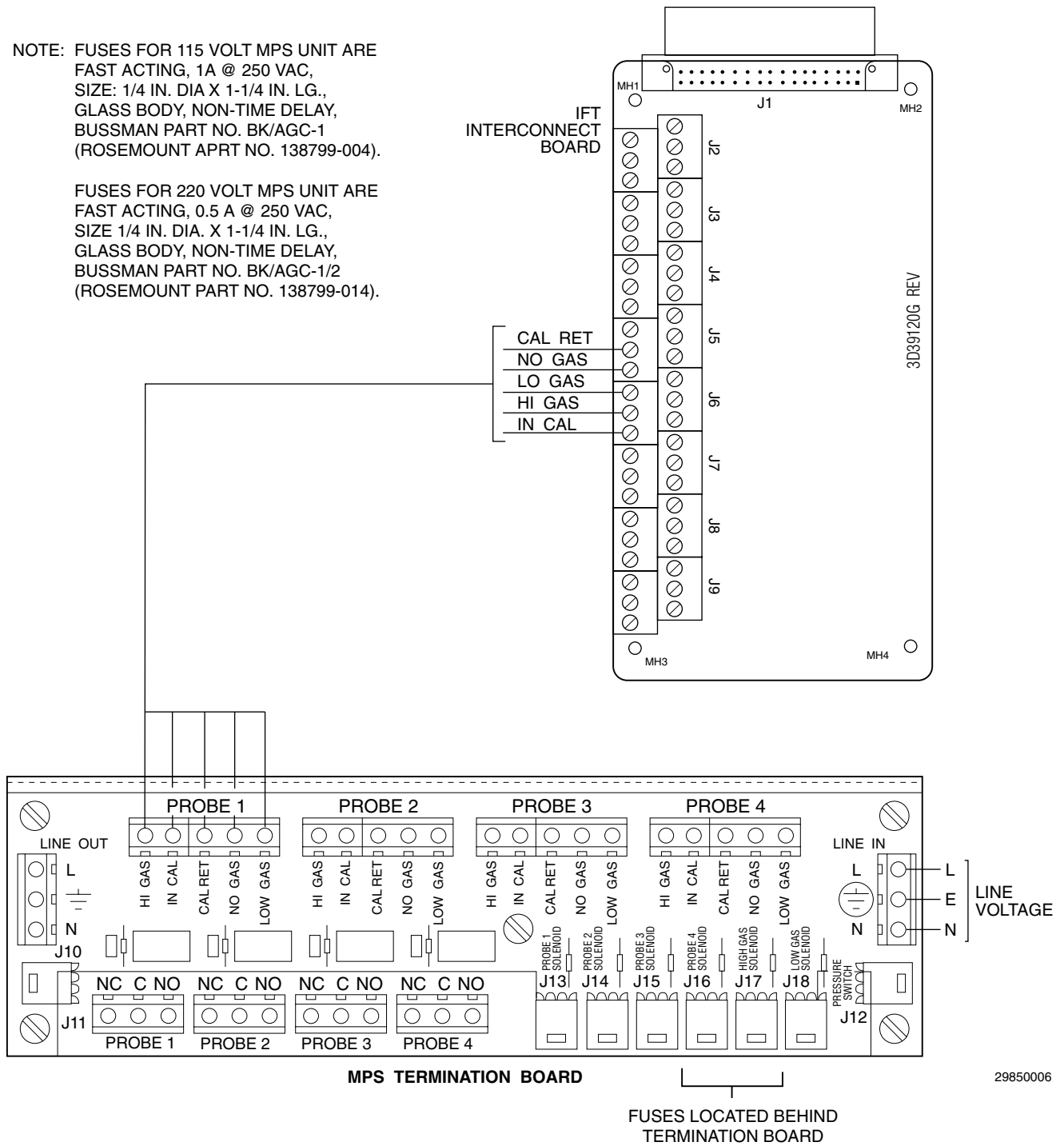

Figure 2-20. MPS Probe Wiring

NOTE

Upon completing installation, make sure that the probe is turned on and operating prior to firing up the combustion process. Damage can result from having a cold probe exposed to the process gases.

CAUTION

Power down all probes during outages. Sensor chamber is heated to 736°C. Further, if ducts will be washed down during the outage, remove the probes to prevent water damage.

Instruction Manual

IB-106-300NH Rev. 4.2

July 2002

World Class 3000

SECTION 3 SETUP

3-1 OVERVIEW

This section provides information on configuring the IFT 3000 Intelligent Field Transmitter. This section assumes that you are familiar with the operation of the IFT and the General User Interface (GUI). If you need additional information on operating the IFT or using the GUI, refer to Section 5, General User Interface (GUI) Operation.

3-2 CONFIGURING THE ANALOG OUTPUT

Use the following procedure to configure the analog output.

- a. Press the SETUP key on the GUI keypad.
- b. Set the Source to the desired measurement value to be represented by the analog output. The choices are O₂, Efficiency, or Dual Rng O₂.
- c. Set the Type to the desired output signal style. The choices are HART 4-20mA, 0-20mA, and 0-10V. The choice selected must agree with the position of the current/voltage selector switch on the IFT microprocessor board. An invalid choice will be discarded. Note that if you are using HART to communicate with the IFT, you must set the analog output type to HART 4-20mA.
- d. The next choice, Range Setup, will vary based on the source selected.
 1. Source set to Efficiency. No range setup is allowed when the source is set to efficiency. Analog output range is fixed at 0-100% efficiency.
 2. Source set to O₂. Range setup allows you to set the transfer function (Xfer Fnct) to either linear or log output. You can also specify the O₂ values represented by the high and low analog output values.

3. Source Set to Dual Rng O₂. Range setup allows you to set the transfer function (Xfer Fnct) to either linear or log output. You can also specify the O₂ values represented by the high and low analog output values for both the normal and high range.

The Mode Setup sub-menu contains entries for setting the range mode, whether the high range is used during calibration, and the point at which the output switches from normal to high range.

For a complete description of all parameters associated with configuring the analog output, refer to Table 5-5.

3-3 SETTING CALIBRATION PARAMETERS

To successfully calibrate a World Class 3000 system, several calibration parameters must be set. These parameters are generally set once and left at those values. These values should only be changed if the system is not calibrating properly, or when changing test gas bottles.

- a. Press the SETUP key on the GUI keypad.
- b. Select the Calibration sub-menu.
- c. Set the High Gas parameter to the oxygen concentration of the high calibration gas. For high calibration gas, 8% oxygen with a balance of nitrogen is recommended.
- d. Set the Low Gas parameter to the oxygen concentration of the low calibration gas. For low calibration gas, 0.4% oxygen with a balance of nitrogen is recommended.
- e. The Auto Cal parameter determines whether the IFT performs automatic or semiautomatic calibrations. In order to perform automatic calibration, the system must be equipped with an MPS 3000 Multiprobe Calibration Gas Sequencer. To perform

automatic calibrations, set the Auto Cal parameter to Yes.

- f. The Output Tracks setting determines whether the analog output tracks the oxygen reading during a calibration. Setting Output Tracks to No locks the analog output value to the last measured oxygen reading until the calibration is complete.
- g. The Cal Interval parameter sets the time in hours and days between automatic calibrations. When Auto Cal is set to NO, this parameter is set to OFF.
- h. The Next Cal parameter displays the time until the next scheduled automatic calibration. If automatic calibration is not enabled, this parameter displays Disabled.
- i. The Gas Time parameter sets the amount of time that calibration gas flows during an automatic calibration before a reading is taken. This value is not used for semiautomatic calibrations.
- j. The Purge Time parameter sets the amount of time after an automatic calibration before the system is returned to normal operation. This allows time for the calibration gases to clear the lines and the system to return to the process gas concentration. This value is not used for semiautomatic calibrations.
- k. The Res Alarm parameter displays the setpoint for the Res Hi alarm. Do not change this parameter unless directed by a qualified Rosemount Service Engineer.
- l. Press the ESC key twice to return to the Main menu.

3-4 SETTING THE O₂ ALARM SETPOINTS

The IFT has a high and low O₂ alarm. To change the alarm setpoints, press the SETUP key on the GUI keypad and select the O₂ Alarms sub-menu.

The Hi Alarm and Lo Alarm values are the settings for the high and low oxygen concentration

alarms, respectively. The Alarm DB parameter allows the setting of an alarm dead band. When a dead band is set, the O₂ value must change by the dead band value before the alarm will reset. For example, if the Hi Alarm is set to 8.00% and the dead band is set to 0.25%, the O₂ concentration must drop to below 7.75% before the O₂ alarm will clear. This prevents the alarms from continually activating and clearing when the oxygen value is near the alarm setpoint.

3-5 CONFIGURING EFFICIENCY CALCULATIONS

To enable efficiency calculations and set the efficiency constants, press the SETUP key on GUI keypad, and select the Efficiency Calc sub-menu. The Enable Calc selection turns efficiency calculation on and off. Enter the K1, K2, and L3 constant values in the appropriate fields. Efficiency constant values are listed in Table 5-6 for oil and gas for the US and Europe.

3-6 CONFIGURING THE RELAY OUTPUTS

The IFT has two relays that can be individually configured. Each relay can be triggered by three separate events selected from a list of eight events. Use the following procedure to configure the relay outputs.

- a. Press the SETUP key on the GUI keypad. Select the Relay Outputs sub-menu.
- b. Select K1 Setup or K2 Setup to configure relay one or relay two, respectively.
- c. Set Event 1, Event 2, and Event 3 to the desired triggering event. The relay will be energized when any of the three events occurs. If you do not want a relay to trigger on three events, set the desired trigger or triggers and set the remaining events to Off.

Note that the TG Low event will only function if the system includes an MPS 3000 Multiprobe Test Gas Sequencer.

- d. Press the ESC key and select the other relay. Configure the relay as described above.
- e. Press the ESC key three times to return to the Main menu.

SECTION 4 CALIBRATION

4-1 ANALOG OUTPUT CALIBRATION

For the analog output to perform within the published specifications, it must be manually calibrated. The only equipment needed to perform the calibration is a voltage or current meter, depending on which mode of operation is to be calibrated. Prior to manual calibration, remove the IFT from any control loops it may be in.

CAUTION

Prior to manual calibration, the IFT should be removed from any automatic control loops. Failure to remove the IFT from control loops prior to calibration may result in faulty equipment performance.

Once initiated from the Setup - Analog Outputs menu, the calibration procedure is self guiding.

4-2 SYSTEM CALIBRATION

a. Overview

The primary purpose of an oxygen analyzer is to give an accurate representation of the percentage of O₂ in the gas stream. The system should be calibrated periodically to maintain an accuracy which may otherwise be reduced over time due to cell aging. A calibration record sheet is provided at the end of this section to track cell performance.

A requirement for calibration is a set of two accurate calibration gases spanning the oxygen range of most interest. For example, 0.4% and 8% for a 0-10% oxygen range.

Under normal conditions the probe should not need frequent calibration. Because calibration is necessary, the system can be equipped with the optional MPS 3000 Multi-probe Calibration Gas Sequencer for fully automatic calibration at regular intervals. Without an MPS, the probes must be calibrated manually (semiautomatically).

b. Probe Calibration

1. Previous Calibration Constants Functionality

There are three sets of registers used to store calibration constants. These are: Latest Calibration, Previous Calibration, and Calculation. Only the values in the Calculation register are used to calculate the oxygen value for display and representation on the analog output signal. These values may be changed in two ways.

- (a) The operator may change the values through the SETUP menu. The operator may adjust the slope and constant individually, or reset both to the values calculated during the last good calibration. To reset the values, move the cursor to RESET SLOPE & CONST and push ENTER.
- (b) The IFT will automatically change the values after each calibration as follows:

The values in the Latest Calibration registers are updated after every complete calibration, even if the calibration is not successful. If the calibration is successful, the values in the Latest Calibration registers are copied into the Previous Calibration registers. This is accomplished prior to the update of the Latest Calibration registers. The new slope and constant are copied into the Calculation register.

If the calibration fails, the Previous Calibration registers retain their existing values, while the Latest Calibration registers record the values of the failed calibration. The Calculation register is not updated when the calibration fails.

2. Calibration Methods

There are three calibration methods: manual (semiautomatic), manually initiated automatic, and fully automatic. Manual (semiautomatic) calibration is done without an MPS unit. Calibration gases are switched on and off by the operator and the IFT is sequenced through the calibration procedure by the operator with the front panel keyboard. The IFT prompts the operator for the correct action. Manually initiated automatic calibration is done with an MPS. The operator manually initiates the calibration at the IFT or through a remote switch, and the IFT controls the operation of the MPS unit and the calibration sequencing. Fully automatic calibration requires no action from the operator. The setup is the same as semiautomatic except the IFT automatically initiates the calibration at a fixed calibration interval. In this mode the operator can also manually initiate calibrations between the intervals in the same manner as semiautomatic calibrations.

c. Manual (Semiautomatic) Calibration

1. Calibration Gases For Manual (Semiautomatic) Calibration

There are two options for supplying calibration gases to the probe during semiautomatic calibration. The first "A" uses refillable bottles and adjustable 2-stage pressure regulators; the second "B" uses disposable bottles and a fixed single stage regulator to provide a mixed flow. Normally, the first (method "A") will have a higher cost and not be portable. The second ("B") is less costly, portable, and weighs about 10 lbs (4.5 kg).

Test Method "A" Fixed Tanks and Manifolds

(a) Required Equipment

CAUTION

Do not use 100% nitrogen as a zero gas. It is suggested that gas for the zero be between 0.4% and 2.0% O₂. Do not use gases with hydrocarbon concentrations of more than 40 parts per million. Failure to use proper gases will result in erroneous readings.

NOTE

Ambient air is not recommended for use as high calibration gas. An 8% O₂ balance in nitrogen is recommended for high calibration gas.

- 1 Two tanks of precision calibration gas mixtures. Recommended calibration gases are nominally 0.4% and 8.0% oxygen in nitrogen.

Two sources of calibrated gas mixtures are:

LIQUID CARBONIC GAS CORP. SPECIALTY GAS LABORATORIES

700 South Alameda Street
Los Angeles, California
90058
213/585-2154

767 Industrial Road
San Carlos, California 94070
415/592-7303

9950 Chemical Road
Pasadena, Texas 77507
713/474-4141

12054 S.W. Doty Avenue
Chicago, Illinois 60628
312/568-8840

603 Bergen Street
Harrison, New Jersey 07029
201/485-1995

255 Brimley Road
Scarborough, Ontario,
Canada
416/266-3161

**SCOTT ENVIRONMENTAL
TECHNOLOGY, INC.
SCOTT SPECIALTY
GASES**

2600 Cajon Blvd.
San Bernardino, CA 92411
714/887-2571
TWX: 910-390-1159

1290 Combermere Street
Troy, MI 48084
314/589-2950

Route 611
Plumsteadville, PA 18949
215/766-8861
TWX: 510-665-9344

2616 South Loop, West
Suite 100
Houston, TX 77054
713/669-0469

- 2 If gas bottles will be permanently hooked up to the probe, a manual block valve is required at the probe (between the calibration fitting and the gas line) to prevent the migration of process gases down the calibration gas line.

If an MPS 3000 Multiprobe Gas Sequencer is used, a check valve is required at the probe.

- 3 Two, 2-stage pressure regulators with stainless steel diaphragms for tanks. Maximum output required: 20 psi (138 kPa).
- 4 One instrument air pressure regulator: 20 psi (138 kPa)

maximum and a supply of clean, dry instrument air.

- 5 Two zero-leakage shutoff valves.
- 6 Miscellaneous oil-free tubing and fittings.

(b) Calibration

- 1 A typical calibration setup is shown in Figure 4-1. Care must be taken that all fittings are tight and free from oil or other organic contaminants. Small openings can cause back diffusion of oxygen from the atmosphere even though positive pressures are maintained in the lines.

NOTE

The probe calibration gas fitting has a seal cap which must be in place at all times except during calibration.

In addition to the precision calibration gas mixtures, clean, dry, oil-free instrument air should be used for calibration.

CAUTION

For optimum accuracy, this calibration should be run with the process at normal temperature and operating conditions.

When the calibration gas line exceeds 6 ft (1.8 m) in length from the leak tight valves, check valve, Rosemount P/N 6292A97H02, should be installed next to the calibration gas connection on the probe to prevent breathing of the line with the process gas and subsequent gas condensation and corrosion.

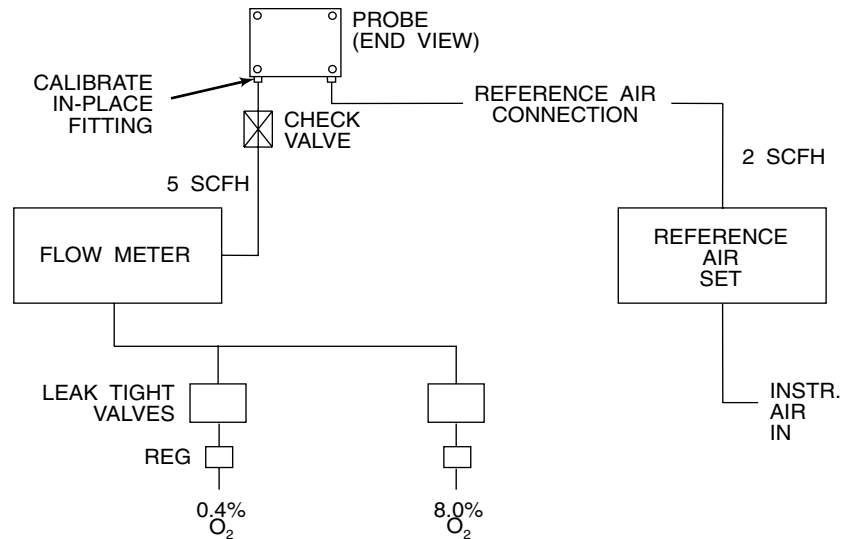

NOTE: PROBE CALIBRATION GAS FITTING HAS A SEAL CAP WHICH MUST BE IN PLACE AT ALL TIMES EXCEPT DURING CALIBRATION.

Figure 4-1. Typical Calibration Setup

NOTE

Only set the calibration gas flowmeter upon initial installation and after changing the diffusion element. A slightly lower calibration gas flow rate may indicate a plugged diffusion element.

- 2 Set the calibration gas pressure regulators and the flow meter for a flow of 5 SCFH at 20 psi (138 kPa) for both gases. The reference air should be flowing as in normal operation.
- 3 Refer to paragraph 4-2d of this section for Manual (Semi-automatic) Calibration setup and procedure using the IFT.
- 4 Calibration gases will be switched on and off using the shutoff valves.

Test Method "B" Rosemount Oxygen Calibration Gas and Service Kit.

(a) Required Equipment

CAUTION

Do not use 100% nitrogen as a zero gas. It is suggested that gas for the zero be between 0.4% and 2.0% O₂. Do not use gases with hydrocarbon concentrations of more than 40 parts per million. Failure to use proper gases will result in erroneous readings.

NOTE

Ambient air is not recommended for use as high calibration gas. An 8% O₂ balance in nitrogen is recommended for high calibration gas.

- 1 Portable Rosemount Oxygen Calibration Gas Kits (Figure 4-2), Rosemount P/N 6296A27G01, containing 8% and 0.4% gases in a portable carrying case with regulator, built-in valve, hose and connecting adapter to the calibration gas connection.

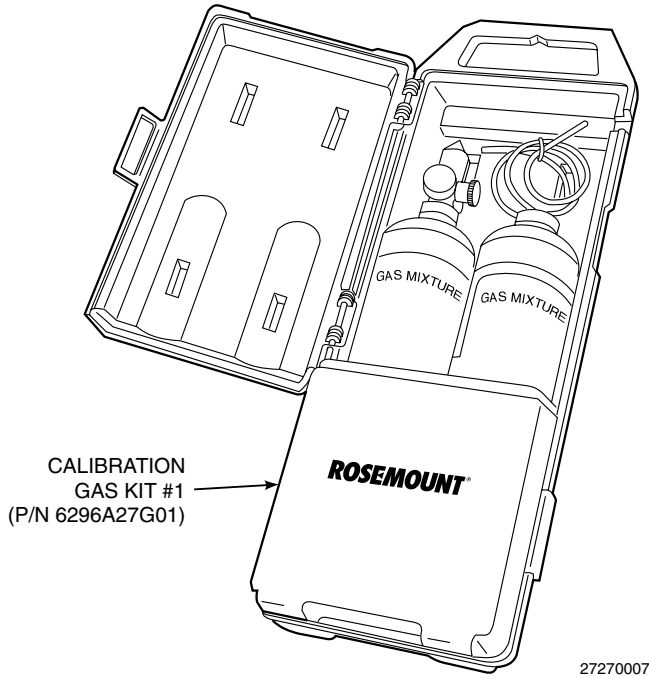

Figure 4-2. Portable Rosemount Oxygen Calibration Gas Kit

- 2 Extra gas bottles are available at:

Rosemount Analytical Inc.
Box 901
Orrville, Ohio 44667
U.S.A.

Rosemount Limited
Burymead Road
Hitchin, Herts. U.K.

Rosemount Italy
VIA Guido Cavalcanti 8
20127 Milan, Italy

Rosemount Spain
Saturnino Calleja 6
28002 Madrid
Spain

Rosemount France
165 Boulevard de Vallmy
92706, Colombes, France

Rosemount P/N 3530B07G01
for probe 0.4% oxygen in ni-
trogen in disposable bottle.

Rosemount P/N 3530B07G02
for probe 8% oxygen in nitro-
gen in disposable bottle.

- 3 A check valve is required at the probe (between the calibration fitting and the gas line) to prevent the migration of process gases down the calibration gas line.

- (b) Calibration with a Portable Rosemount Oxygen Calibration Gases Kit.

- 1 A typical portable calibration setup is shown in Figure 4-3. For manual (semiautomatic) calibration, remove cap plug from the calibrate in place fitting. The cap plug must be retained to seal this fitting after calibration is complete; failure to do so may render the probe useless if the system pressure is slightly negative. The reference air should be flowing as in normal operation.

- 2 Refer to paragraph 4-2.d of this section for Manual (Semi-automatic) Calibration setup and procedure using the IFT.

- 3 Screw the pushbutton regulator with contents gage on to the calibration gas of choice and inject the calibration gas by opening the valve. Gas is on continuously when the valve is opened.

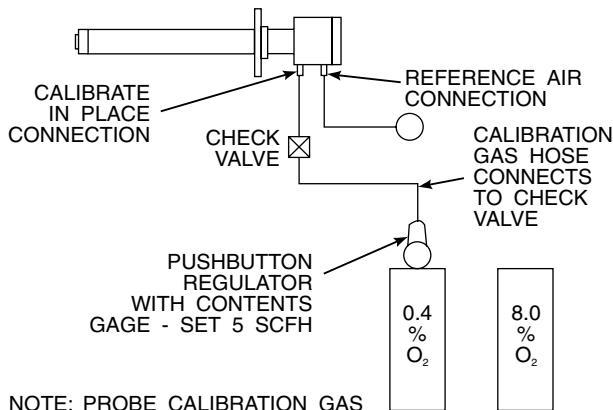

NOTE: PROBE CALIBRATION GAS FITTING HAS A SEAL CAP WHICH MUST BE IN PLACE EXCEPT DURING CALIBRATION.

27270005

Figure 4-3. Typical Portable Calibration Setup

d. Manual (Semiautomatic) Calibration Procedure

The following procedure relates to an operator initiated calibration selected at the IFT by pressing the CAL key. The calibration is manually performed by the operator upon data queues from the IFT. Any system without an MPS 3000 Multiprobe Calibration Gas Sequencer must follow these steps.

1. Press SETUP to display the SETUP menu. Select PROBE CALIBRATION sub-menu. Ensure that Auto Cal is disabled. Set the cursor on Auto Cal. Press ENTER. Set Auto Cal to NO if not already done.
2. Press the CAL key. Select PERFORM CALIBRATION sub-menu. "Press ENTER to start Manual Calibration" will appear on the LCD display. Press

ENTER to start. Follow the data queues. Refer to Table 5-4, CALIBRATE O₂ Sub-menu.

e. Fully Automatic Calibration

1. Calibration Gases For Fully Automatic Calibration. For fully automatic calibration, an MPS 3000 Multiprobe Calibration Gas Sequencer is required as well as the two types of calibration gas.

CAUTION

Do not use 100% nitrogen as a zero gas. It is suggested that gas for the zero be between 0.4% and 2.0% O₂. Do not use gases with hydrocarbon concentrations of more than 40 parts per million. Failure to use proper gases will result in erroneous readings.

NOTE

Ambient air is not recommended for use as high calibration gas. An 8% O₂ balance in nitrogen is recommended for high calibration gas.

Two tanks of precision calibration gas mixtures. Recommended calibration gases are nominally 0.4% and 8.0% oxygen in nitrogen set calibration gas pressure at 20 psi (138 kPa).

A typical automatic calibration system is shown in Figure 4-4.

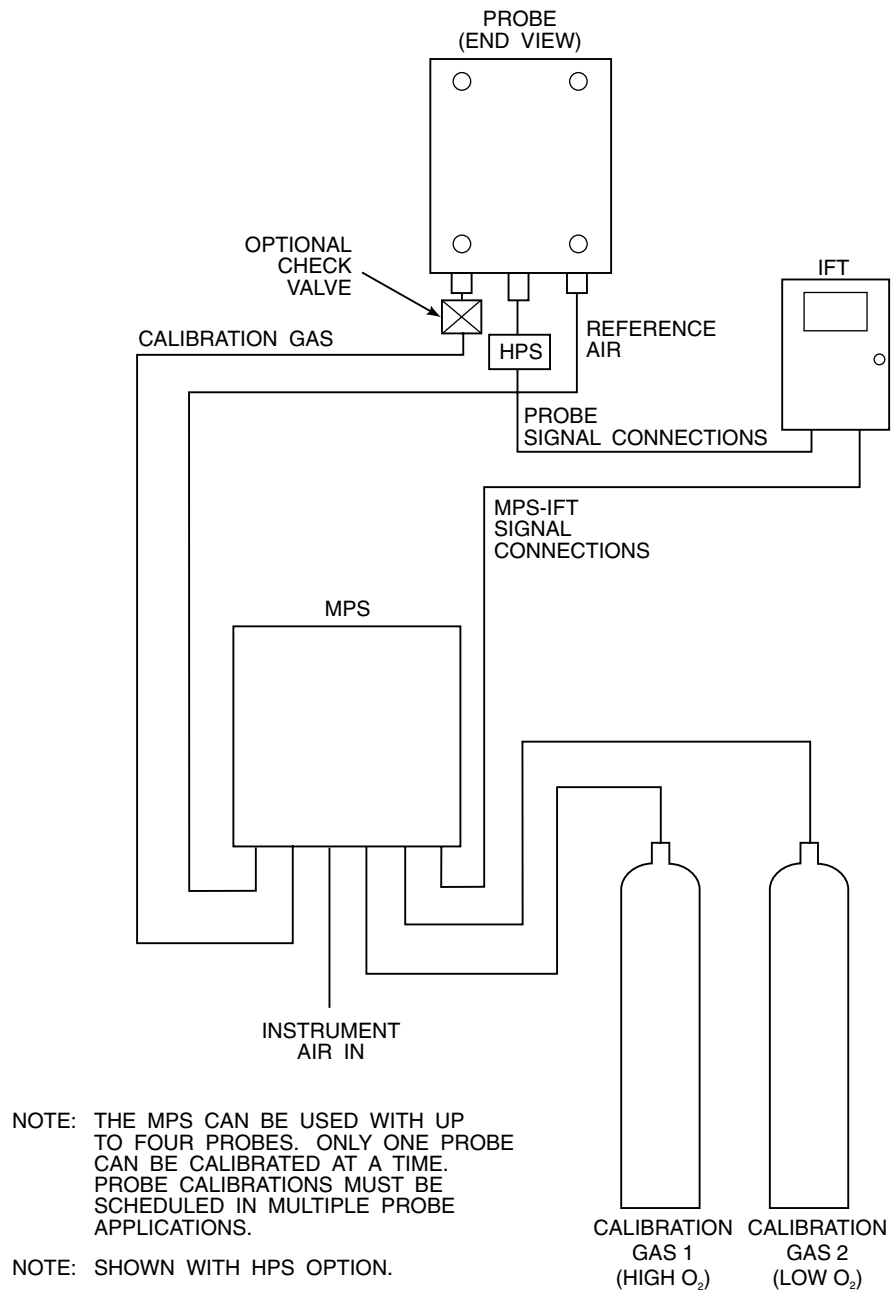

27270006

Figure 4-4. Typical Automatic Calibration System

Table 4-1. Automatic Calibration Parameters

Auto Cal YES/NO	Set to YES
Output Tracks YES/NO	Set as desired to configure analog output tracking.
Cal Intvl XD XH	Set the desired time between calibrations in number of days and hours (1 year max).
Next Cal. XD XH	Displays the time left to the start of the next calibration. Set the desired time until the start of the next calibration (1 year max). If nothing is entered here, the unit will automatically enter the Cal Intvl and count down from that.
Gas Time 0:00	Set the amount of time for calibration gases to be turned on in minutes and seconds; allow enough time for signal value to stabilize.
Gas Time 0:00	Set the amount of time for calibration gases to be turned on in minutes and seconds; allow enough time for signal value to stabilize.
Purge Time 0:00	Set the amount of time for the gas lines to clear in number of minutes and seconds.
Abort Time 0:00	Set the amount of time allowed between key functions before the calibration procedure is aborted in number of minutes and seconds.
Res Alarm _____	Set the desired resistance alarm between 50 to 10,000 ohms.

2. Fully Automatic Calibration Setup. In order for the IFT system to calibrate automatically, the parameters from the CALIBRATE sub-menu (shown in Table 4-1) in the IFT have to be entered.

Once these parameters have been set, the system will initiate calibration without operator intervention as set by the CAL INTVL parameter.

3. Manually Initiated Fully Automatic Calibration Procedure. The following procedure relates to an operator initiated calibration, either by a remote switch (CAL INIT on interconnect board) or selected at the IFT by pressing the CAL key using an MPS 3000 Multi-probe Gas Sequencer.

(a) Press SETUP to display the SETUP sub-menu. Select Calibration. Ensure that Auto Cal is enabled. Set the cursor on Auto Cal. Press ENTER. Set Auto Cal to YES if not already done.

(b) Press the CAL key. Select Perform Calibration. "Press ENTER to start Automatic Calibration" will appear on the LCD display. Press ENTER to start. Refer to Table 5-5, CALIBRATE O₂ Sub-Menu.

Instruction Manual

IB-106-300NH Rev. 4.2

July 2002

World Class 3000

SECTION 5

GENERAL USER INTERFACE (GUI) OPERATION

5-1 OVERVIEW

Ensure that the oxygen analyzer, heater power supply, and intelligent field transmitter have been properly connected. It is important to check that grounding and screening of terminations are correctly made to prevent the introduction of ground loops. The IFT is equipped with noise suppression circuitry on the power supply and signal input lines. Proper grounding at installation will ensure accuracy of function.

The following five languages are can be selected within the IFT:

English	Italian
French	Spanish
German	

NOTE

Support the keypad with the free hand to prevent bounce back of the IFT door.

a. Intelligent Field Transmitter (IFT)

The Intelligent Field Transmitter may be supplied with either of two configurations. These are the blind version and the deluxe version. The two versions differ as follows:

1. **Blind Version.** The blind version has no display and no keypad. With this version an external HART communications device is required.
2. **Deluxe Version (GUI).** The deluxe version is also known as the General User Interface (GUI) version. This IFT contains an LED display, liquid crystal display panel, and an eight-key pad from which the probe and electronics can be configured, calibrated and troubleshooted.

b. HART Communicator Interface Devices

The HART communications protocol can interface with any of the above IFT versions. To interface a HART communicator with an IFT, one of three interface devices is required. The interface devices are as follows:

1. **Rosemount Model 275 Handheld Communicator.** The handheld communicator requires Device Descriptor (DD) software specific to the World Class 3000 product. The DD software will be supplied with many model 275 units, but can also be programmed into existing units at most Fisher-Rosemount service offices.
2. **Personal Computer (PC).** The use of a personal computer requires Cornerstone software with Module Library (ModLib) specific to the World Class 3000 product.
3. **Selected Distributed Control Systems.** The use of distributed control systems requires input/output (I/O) hardware and software which permit HART communications.

This section of the manual deals with operator controls and displays available with the GUI equipped IFT. Operating parameters are listed and instructions are included for viewing and changing them.

Any procedures not associated with normal operation are included in Section 2, Installation, or Section 5, Troubleshooting.

5-2 DELUXE VERSION IFT DISPLAYS AND CONTROLS

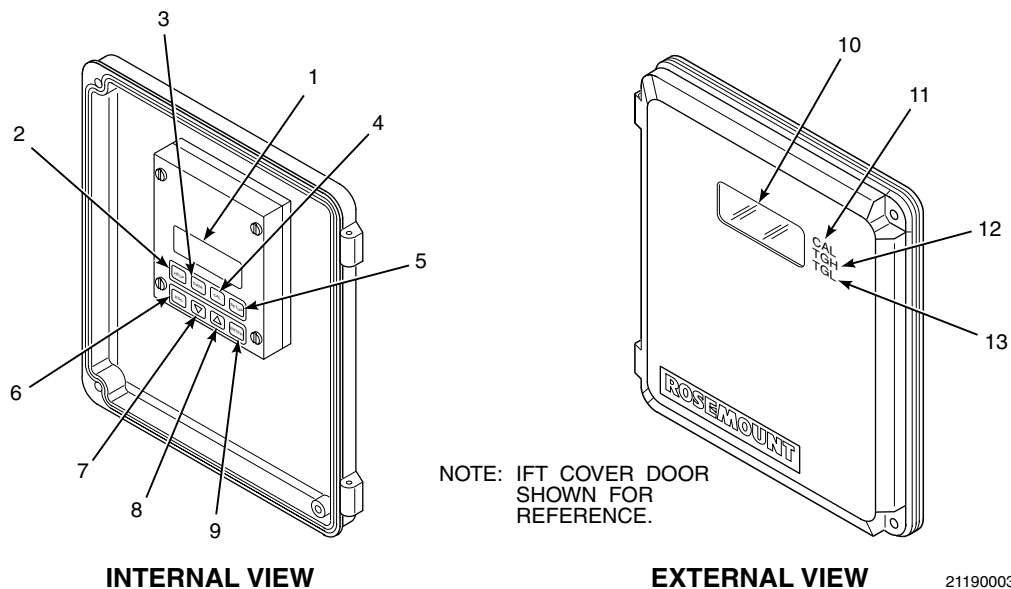

Figure 5-1. Deluxe Version IFT Displays and Controls

Figure 5-1
Index No.

Index No.	Control/LED	Description
1	LCD Display	Top line displays system status, menu, and probe number.
2	HELP	Context sensitive HELP is displayed when this key is pressed.
3	DATA	DATA key is used to access DATA menu.
4	CAL	CAL key used to access CALIBRATE menu.
5	SETUP	SETUP key used to access SETUP menu.
6	ESC	The escape key is used to exit to a high level menu or to abort a parameter change.
7	∨	The decrease key is used to move the cursor (asterisk) when scrolling through lists or to decrease a parameter value.
8	∧	The increase key is used to move the cursor (asterisk) when scrolling through lists or to increase a parameter value.
9	ENTER	The ENTER key is used to select a lower level menu, initiate calibration, or select a parameter to change.
10	LED Display	Indicates current O ₂ or calibration gas value.
11	CAL	Calibration in progress indicator light.
12	TGH	High calibration gas indicator light. High calibration gas is being used in calibration process.
13	TGL	Low calibration gas indicator light. Low calibration gas is being used in calibration process.

Table 5-1. Sample HELP Messages

MENU, SUB-MENU, HELP OR PARAMETER NAME	MESSAGE
PROBE DATA	Press ENTER key to access DATA menu.
CALIBRATE O ₂	The CAL menu is used to start calibration and view calibration.
SETUP	The SETUP menu is used to configure the IFT 3000.

5-3 HELP KEY

The HELP key will display explanatory information about a menu, sub-menu, or parameter that the asterisk is next to when pressed. The HELP key is not available during calibration routines. Refer to Table 4-1 for sample HELP messages.

5-4 STATUS LINE

The top line of the LCD display (1, Figure 5-1) is a status line that always displays system status, menu name, and O₂ level. System status displays will be displayed one at a time in priority sequence, as follows:

- a. **Off** - The probe has been turned off because the IFT cannot control the heater temperature.
- b. **PrbEr** - The probe is disconnected, cold, or leads are reversed.
- c. **HtrEr** - Heater error.
- d. **InCAL** - Calibration in progress.
- e. **Low O₂** - O₂ value is below the low alarm limit.
- f. **HiO₂** - O₂ value is above the high alarm limit.
- g. **NoGas** - Calibration gas pressure is low.
- h. **CalEr** - Calibration error.
- i. **ResHi** - Resistance is above the high limit.
- j. **OK** - System is functioning correctly.

5-5 QUICK REFERENCE CHART

The quick reference chart (Figure 5-2) is designed to help you get where you want to be in the menu system. The chart shows all the available menu and sub-menu options for the IFT. Follow the lines to determine which menu choices to make. Moving down a level on the chart is accomplished by the use of the ENTER key. To move up a level on the chart, press the ESCAPE key.

5-6 MAIN MENU

When power is first applied to the IFT, the MAIN menu (Table 5-2) is initially displayed. It is from the MAIN menu that the PROBE DATA (Table 5-3), CALIBRATE O₂ (Table 5-4), and SETUP (Table 5-5) menus can be accessed.

Table 5-2. MAIN menu

MENU SELECTION	DESCRIPTION
PROBE DATA	Refer to Table 5-3.
CALIBRATE O ₂	Refer to Table 5-4.
SETUP	Refer to Table 5-5.

5-7 PROBE DATA SUB-MENU

The PROBE DATA sub-menu is a list of all the parameters of the system as it is currently configured. To access the PROBE DATA sub-menu, press the DATA key at any time. The increase and decrease keys are used to scroll through the list. The PROBE DATA sub-menu can be viewed but not changed. The operator must use the SETUP menu to change any of the parameters.

There are two selections available on the PROBE DATA sub-menu; Process Data and Diagnostic Data. Refer to Table 5-3 for contents of the sub-menu.

5-8 CALIBRATE O₂ SUB-MENU

The CALIBRATE O₂ sub-menu (Table 5-4) is used to enter the calibration mode. To access the CALIBRATE O₂ sub-menu, press the CAL key at any time. The increase and decrease keys are used to scroll through the list.

The CALIBRATE O₂ sub-menu has three selections available: Perform Calibration, View Constants, and Calibration Status. Refer to Table 5-4 for contents of the sub-menus.

Perform Calibration has two options depending on how Auto Cal is selected in Probe Setup. Refer to SETUP Setting in Table 5-4.

For information on performing a calibration, refer to Section 4, Calibration.

5-9 SETUP SUB-MENU

The SETUP sub-menu is used to enter all operator set variables into the system. To access the SETUP sub-menu press the SETUP key at any time. To select the parameter to be changed, move the cursor to the desired parameter using the arrow keys. Press ENTER to select that parameter. To change the value for that parameter, use the arrow keys to increase or decrease the value. Press ENTER to save changes.

There are six selections available on the SETUP sub-menu: Calibration, O₂ Calculation, O₂ Alarms, Efficiency Calc., Relay Outputs, and Analog Outputs. Refer to Table 5-5 for the contents of the SETUP sub-menu, or ESCAPE to abort changes.

Table 5-3. PROBE DATA Sub-Menu

SUB-MENU SELECTION	PARAMETER	DESCRIPTION
<u>Process Data</u>	O ₂ __% O ₂ Efficiency __% Stack Temp __DegC	O ₂ value for the probe. Efficiency display. Stack temperature.
<u>Diagnostic Data</u>		
Temperature	Cell __DegC Stack __DegC Cold Junct __DegC	Cell temperature of the probe. Stack temperature. Cold Junction temperature.
Voltages	Cell __mV Cell T/C __mV Stk T/C __mV Cold Jnt __mV	Cell voltage of the probe. Cell thermocouple voltage of the probe. Stack thermocouple voltage. Cold junction voltage.
Output Values	Analog __% FS K1 State OFF/ON K2 State OFF/ON	Analog output voltage. Status of relay 1. Status of relay 2.

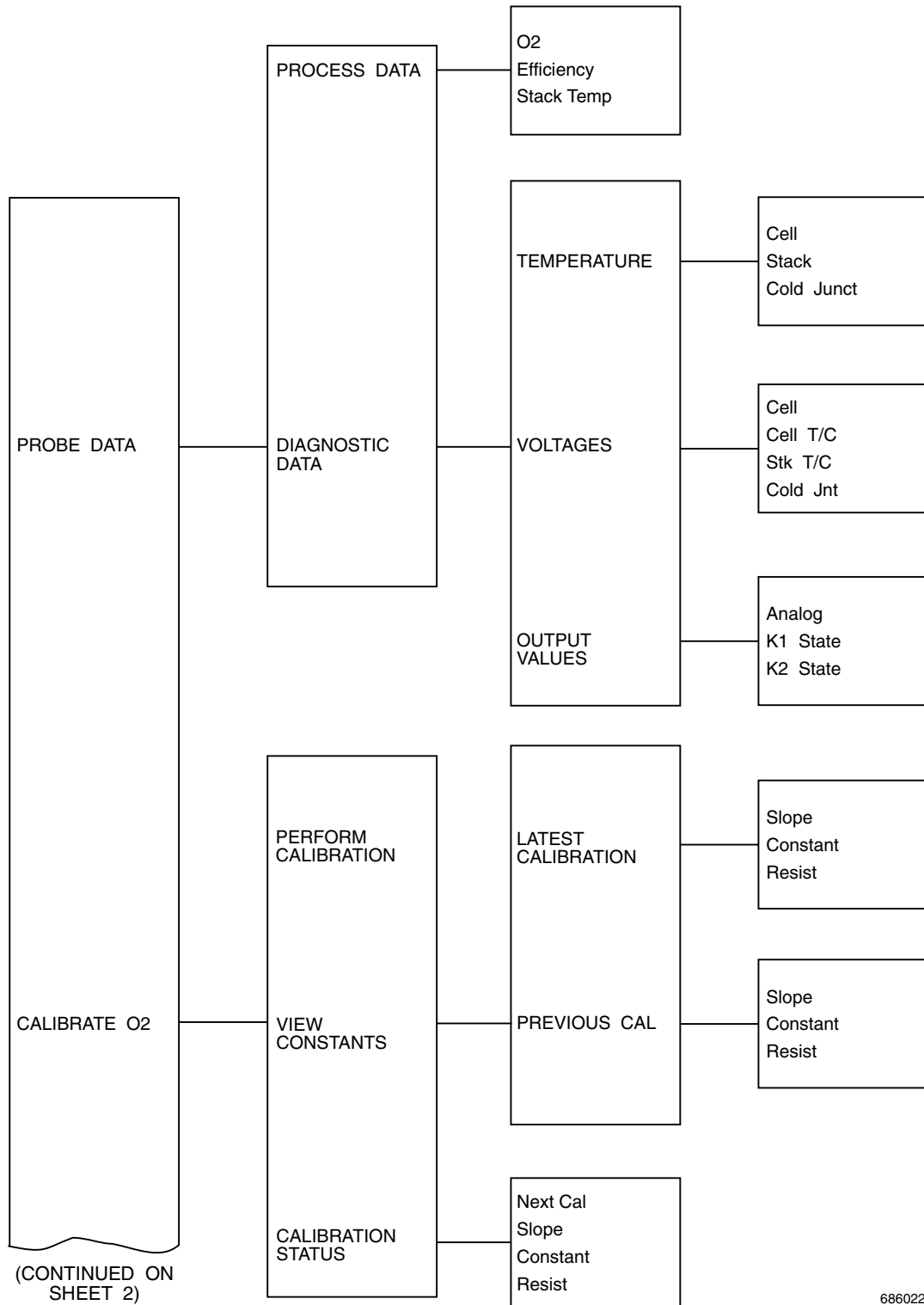

(CONTINUED ON SHEET 2)

686022

Figure 5-2. Quick Reference Chart (Sheet 1 of 5)

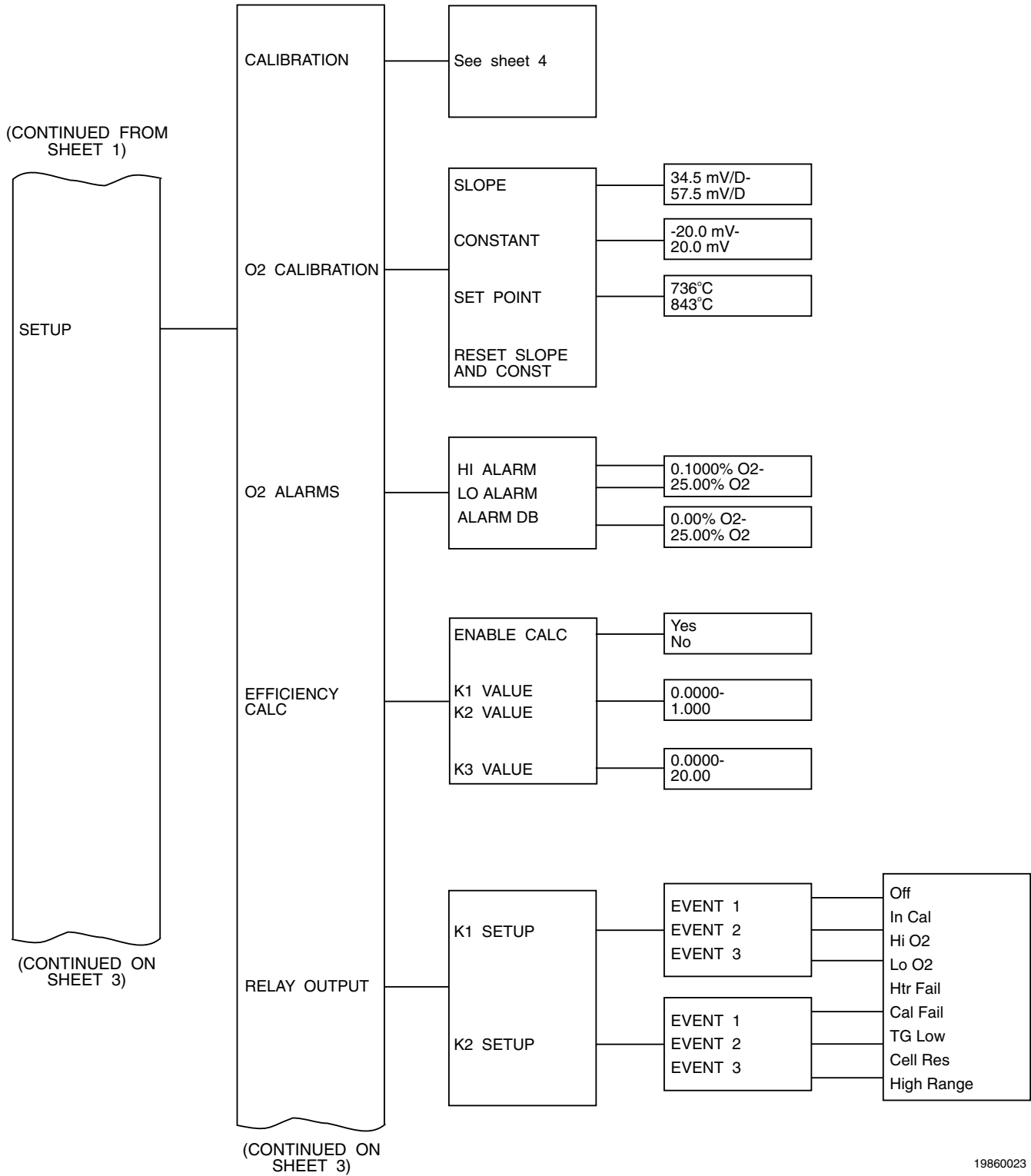
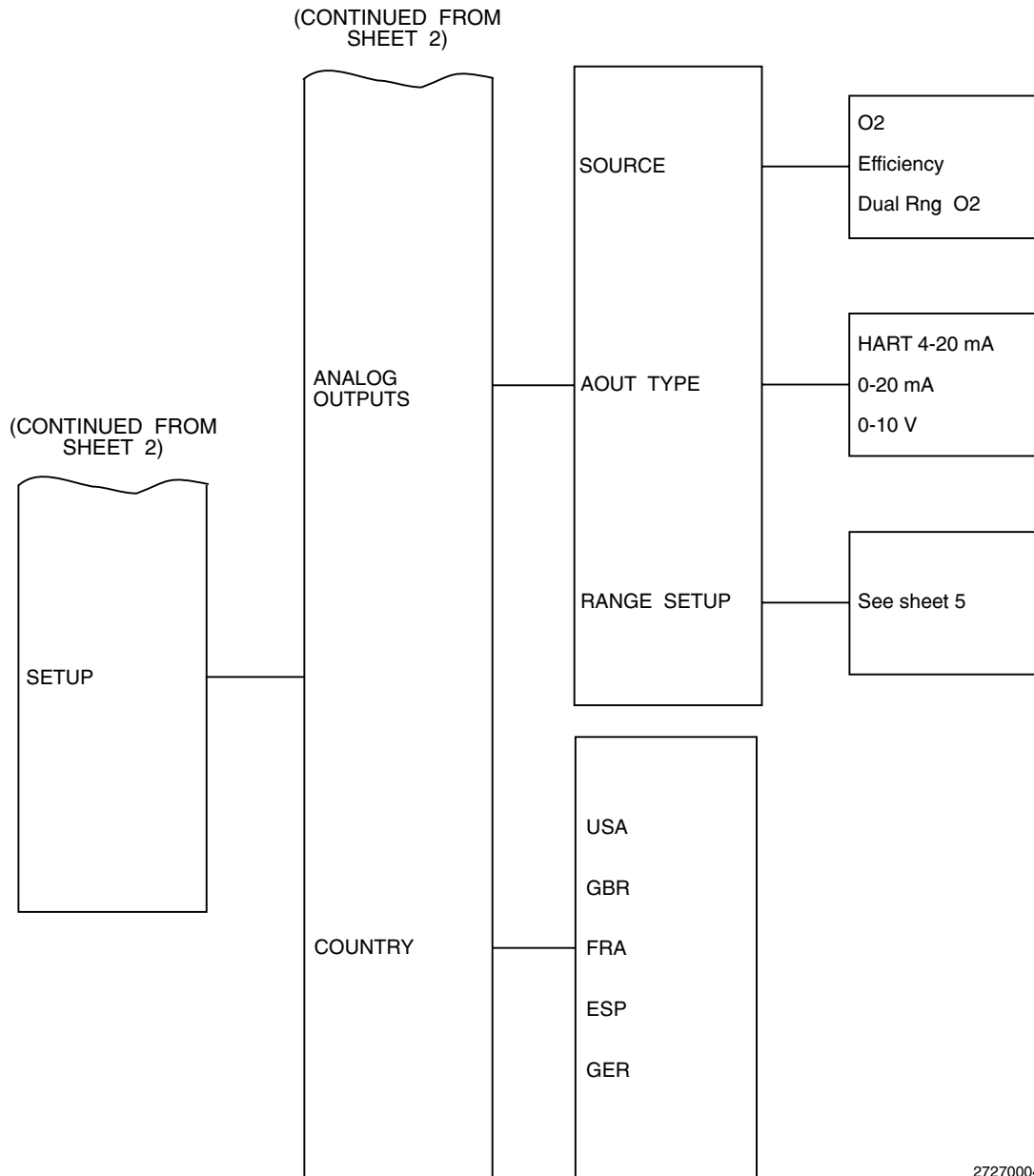
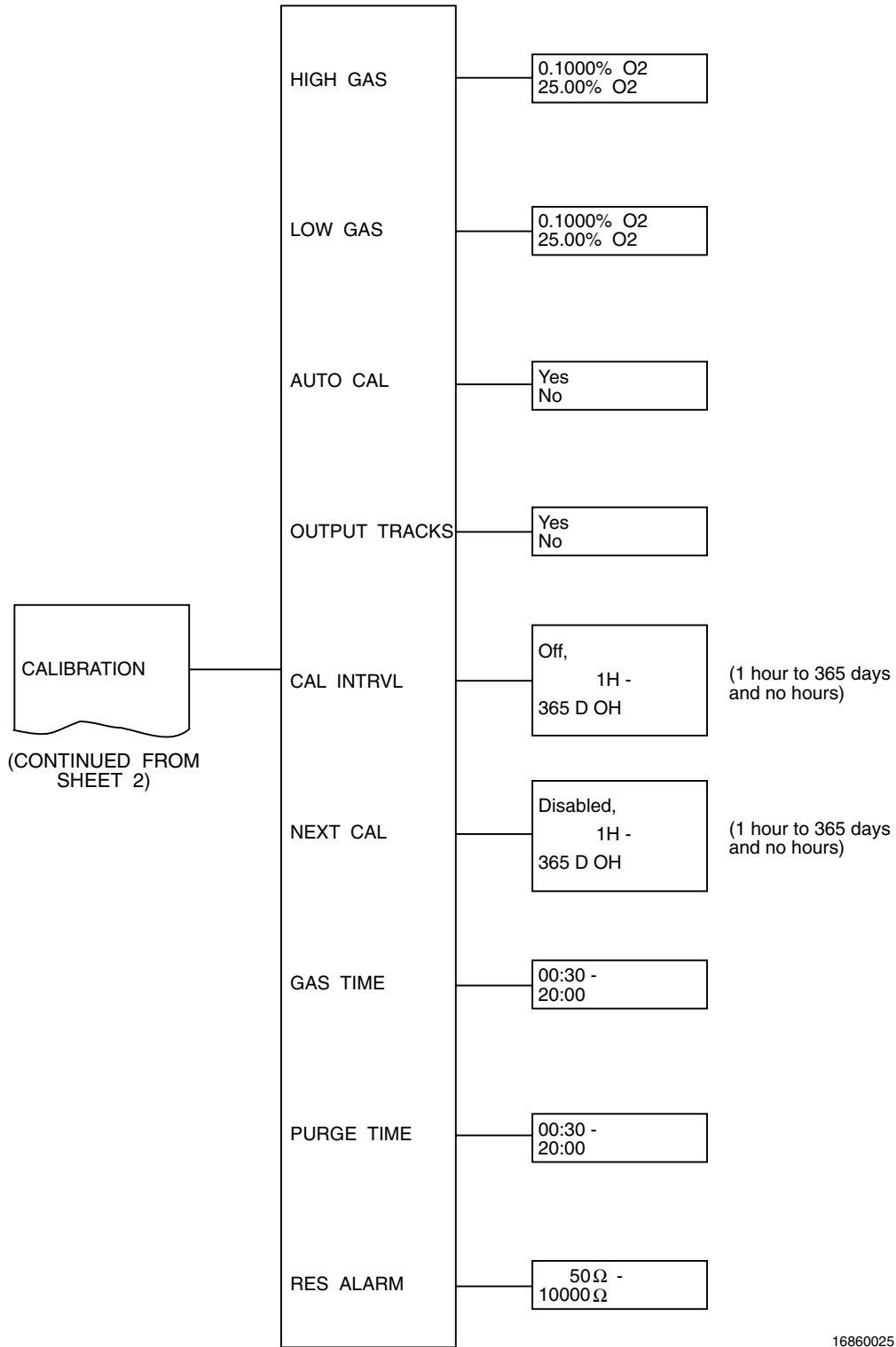

Figure 5-2. Quick Reference Chart (Sheet 2 of 5)



27270004

Figure 5-2. Quick Reference Chart (Sheet 3 of 5)



16860025

Figure 5-2. Quick Reference Chart (Sheet 4 of 5)

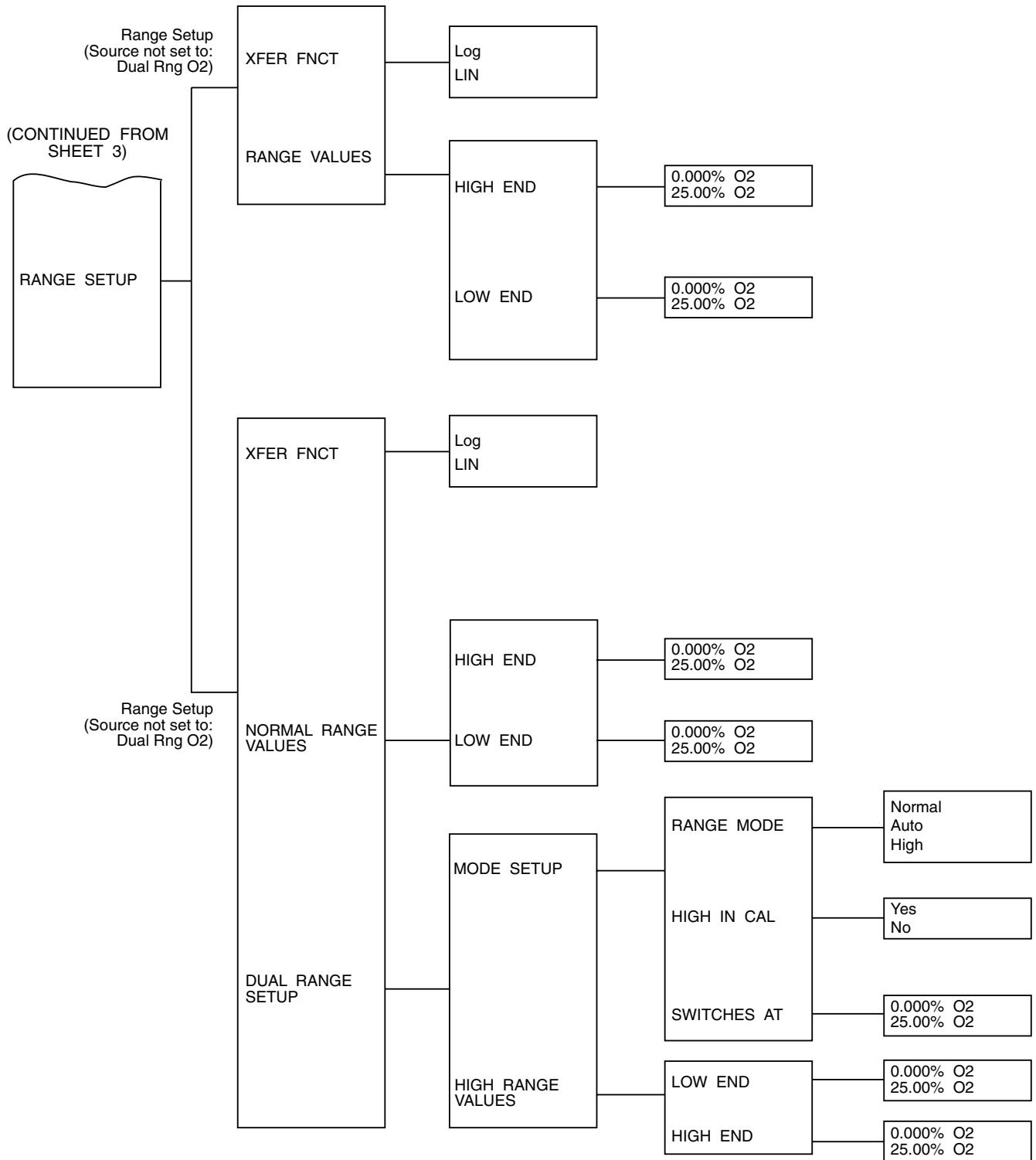

16860026

Figure 5-2. Quick Reference Chart (Sheet 5 of 5)

Table 5-4. CALIBRATE O₂ Sub-Menu

SUB-MENU SELECTION	SETUP SETTING (SEE TABLE 3-5)	DISPLAY	DESCRIPTION
<p><u>Perform Calibration</u></p>	<p>Auto Cal in Probe Setup is YES</p>	<p>Press ENTER to start Auto Calibration. Starting Automatic Calibration High Gas _____% O₂ Time Left 0:00</p> <p>Cell mV _____mV Low Gas _____% O₂ Time Left 0:00</p> <p>Cell mV _____mV Resistance Check Time Left 0:00 Cell _____mV _____C Calibration Complete Purging 0:00</p> <p>Cell _____mV _____C Calibration Complete</p>	<p>MPS will start calibrating probe.</p> <p>Value for high O₂ calibration gas. Amount of time necessary to complete the current testing phase in min:sec.</p> <p>Cell voltage of the probe.</p> <p>Value for low O₂ calibration gas. Amount of time necessary to complete the current testing phase in min:sec.</p> <p>Cell voltage of the probe.</p> <p>Resistance check in progress.</p> <p>Cell voltage and probe temperature.</p> <p>Gas lines are being purged of calibration gas.</p> <p>Cell voltage and probe temperature.</p>
	<p>Auto Cal in Probe Setup is NO.</p>	<p>Press ENTER to start Manual Calibration. Switch ON high calibration gas. Press ENTER when ready. High gas _____% O₂ Press ENTER when O₂ reading is stable. Turn OFF high calibration gas and ON low calibration gas. Press ENTER when ready. Low gas _____% O₂ Press ENTER when O₂ reading is stable. Resistance Check. Turn off low calibration gas. Press ENTER when ready. Press ENTER when probe has returned to process.</p>	<p>Manual calibration sequence will begin when ENTER is pressed.</p> <p>High O₂ calibration gas value.</p> <p>Low O₂ calibration gas value.</p> <p>Resistance check in progress.</p>

Table 5-4. CALIBRATE O₂ Sub-Menu (continued)

SUB-MENU SELECTION	SETUP SETTING (SEE TABLE 3-5)	DISPLAY	DESCRIPTION
<u>View Constants</u>	Latest Calibration Previous Calibration	Slope ____mV/D Constant ____mV Resist ____ohms Slope ____mV/D Constant ____mV Resist ____ohms	Slope for probe from latest calibration. Latest calibration offset for probe. Latest calibration resistance of probe. Slope for probe from previous calibration. Previous calibration offset for probe. Previous calibration resistance of probe.
<u>Calibration Status</u>	N/A	Next Cal XD XH Slope ____ Constant ____ Resist ____	Time until next calibration in number of days and number of hours. Status of the slope. Status of the offset. Status of the resistance.

Table 5-5. SETUP Sub-Menu

SUB-MENU SELECTION	PARAMETERS	DESCRIPTION
<u>Calibration</u>	High Gas _____% O ₂ Low Gas _____% O ₂ Auto Cal YES/NO Output Tracks YES/NO Cal Intrvl XD XH Next Cal XH Gas Time 0:30 - 20:00 Purge Time 0:30 - 20:00 Res Alarm 50 W – 10 kW	Value of high O ₂ calibration gas (0.1000% - 25.00% O ₂). Value of low O ₂ calibration gas (0.1000% - 25.00% O ₂). MPS required for Auto Cal. NO, locks output during calibration. Select time between calibrations in number of days and hours (1 year max). Time until next calibration in number of hours (1 year max). Amount of time calibration gases will be turned on in number of minutes and seconds; allow enough time for signal values to stabilize. Amount of time for gas lines to clear of calibration gas. Resistance alarm set from 50 to 10,000 ohms.
<u>O₂ Calculation</u>	Slope _____ mV/D Constant _____ mV Set Point _____ °C	Set value between 34.5 and 57.5. Set value between -20.0 and +20.0 mV. Set either 736 for World Class 3000 probes or 843 for 218 probes.
<p>CAUTION</p> <p>Ensure the correct voltage is selected when using HPS 3000 with either World Class 3000 probes or 218 probes. Refer to Figure 2-15, Jumper Selection Label for proper voltage selections. If incorrect SET POINT is selected, damage to the probe may occur.</p>		
	Reset slope and constants.	Press ENTER to reset slope and constants to values from the latest successful calibration.
<u>O₂ Alarms</u>	Hi Alarm _____% O ₂ Lo Alarm _____% O ₂ Alarm DB _____% O ₂	Set value for high alarm limit (0.1000% - 25.00%). Set value for low alarm limit (0.1000% - 25.00%). Set value for alarm dead band (0.0000% - 25.00%).
<u>Efficiency Calc.</u>	Enable Calc. YES/NO K1 Value _____ K2 Value _____ K3 Value _____	Select YES to enable, NO to disable. Set between 0.0000 and 1.000. Refer to Table 5-6. Set between 0.0000 and 1.000. Refer to Table 5-6. Set between 1.000 and 20.00. Refer to Table 5-6.

Table 5-5. SETUP Sub-Menu (continued)

SUB-MENU SELECTION	PARAMETERS	DESCRIPTION
<p><u>Relay Outputs</u></p> <p>K1 Setup</p> <p>K2 Setup</p>	<p style="text-align: center;">NOTE</p> <p>K1 and K2 relay outputs can be configured for "OFF" or any one of the eight events listed below. Up to three events can control each relay output. Events are selected in the SETUP sub-menu.</p> <p>- Off</p> <p>Event 1 1. In Cal</p> <p>Event 2 2. Hi O₂</p> <p>Event 3 3. Lo O₂</p> <p>Event 1 4. Htr Fail</p> <p>Event 2 5. Cal Fail</p> <p>Event 3 6. TG Low</p> <p>7. Cell Res</p> <p>8. High Range</p>	<p>No effect.</p> <p>Probe goes into calibration status.</p> <p>Output exceeds high end alarm limit.</p> <p>Output goes below low alarm limit.</p> <p>Probe heater fault occurs.</p> <p>Probe failed last calibration.</p> <p>Calibration gas pressure gets too low.</p> <p>Probe resistance exceeds high limit.</p> <p>High analog output range is selected.</p>
<p><u>Analog Output</u></p>	<p><u>SOURCE</u> O₂ Efficiency Dual Rng O₂</p> <p><u>AOUT TYPE</u> HART 4-20mA 0-20mA 0-10V</p> <p><u>RANGE SETUP</u> (Source not set to Dual Rng O₂)</p> <p>Xfer Fnct Log Lin</p> <p>Range Values High End 0.000% O₂ - 25.00% O₂ Low End 0.000% O₂ - 25.00% O₂</p>	<p>Select the measurement value to be represented on the analog output.</p> <p>Select one of the listed options to define upper and lower limits of probe analog output. Only a selection that matches the position of the analog output selector switch on the microprocessor board (Figure 2-9) will be accepted. The defined limits correspond to the upper-lower %O₂ values defined in the Range Setup menu.</p> <p>Select the transfer function used on the analog output. Selecting Log will not effect the output when Efficiency is selected as the Source.</p> <p>Enter the upper and lower analog output range values. The High End value defines the measured O₂ value corresponding to the high analog output value, i.e., 20mA or 10V, and the Low End value corresponds to the low analog output value, i.e., 0mA, 4mA, or 0V.</p>

Table 5-5. SETUP Sub-Menu (continued)

SUB-MENU SELECTION	PARAMETERS	DESCRIPTION
Analog Output (continued)	<p>RANGE SETUP (Source set to Dual Rng O₂)</p> <p>Xfer Fnct Log Lin</p> <p>Normal Range Values</p> <p> High End 0.000% O₂ - 25.00% O₂</p> <p> Low End 0.000% O₂ - 25.00% O₂</p> <p>Dual Range Setup</p> <p> <u>Mode Setup</u></p> <p> Range Mode Normal Auto</p> <p> High</p> <p> High in Cal Yes/No</p> <p> Switches at 0.000% O₂ - 25.00% O₂</p> <p> <u>High Range Values</u></p> <p> High End 0.000% O₂ - 25.00% O₂</p> <p> Low End 0.000% O₂ - 25.00% O₂</p>	<p>Select the transfer function used on the analog output. Selecting Log will not effect the output when Efficiency is selected as the Source.</p> <p>Enter the upper and lower analog output range values for Normal Operating Range. The High End value defines the measured O₂ value corresponding to the high analog output value, i.e, 20mA or 10V, and the Low End value corresponds to the low analog output value, i.e., 0mA, 4mA, or 0V.</p> <p>Forces the output to the Normal Range.</p> <p>Allows the IFT to select either the High Range or the Normal Range based on the present O₂ value and the Mode Setup Values.</p> <p>Forces the output to the High Range.</p> <p>Selecting Yes will cause the High Range to be used whenever the probe is being calibrated.</p> <p>Enters the switching point between the High and Normal Ranges. O₂ values above this point will use the High Range and values below this point will use the Normal Range. The O₂ value must be below the switch point by 10% (of the "Switches at" value) to cause a switch from High to Normal Range.</p> <p>Enter the upper and lower analog output range values for High Operating Range. The High End value defines the measured O₂ value corresponding to the high analog output value, i.e., 20mA or 10V, and the Low End value corresponds to the low analog output value, i.e., 0mA, 4mA, or 0V.</p>

NOTE: Relay output can be initiated upon range change. (See page 5-12 of Table 5-5.)

Table 5-6. Efficiency Constants

CONSTANT	UNITED STATES		EUROPE	
	GAS	OIL	GAS	OIL
K1	0.407	0.432	0.66	0.69
K2	0.0	0.0	0.0082	0.0051
K3	5.12	5.12	12.28	8.74

SECTION 6 TROUBLESHOOTING

6-1 OVERVIEW

The system troubleshooting describes how to identify and isolate faults which may develop in the Oxygen Analyzer System. Refer to Probe, IFT, HPS, MPS, and HART Communicator appendices.

WARNING

Install all protective equipment covers and safety ground leads after troubleshooting. Failure to replace covers and ground leads could result in serious injury or death.

6-2 SPECIAL TROUBLESHOOTING NOTES

a. Grounding

It is essential that adequate grounding precautions are taken when the system is being installed. A very thorough check must be made at both the probe and electronics to ensure that the grounding quality has not degraded during fault finding. The system provides facilities for 100% effective grounding and the total elimination of ground loops.

b. Electrical Noise

The IFT has been designed to operate in the type of environment normally found in a boiler room or control room. Noise suppres-

sion circuits are employed on all field terminations and main inputs. When fault finding, the electrical noise being generated in the immediate circuitry of a faulty system should be evaluated. All cable shields must be connected to earth.

c. Loose Integrated Circuits

The IFT uses a microprocessor and supporting integrated circuits. Should the electronics unit receive rough handling during installation in a location where it is subjected to severe vibration, an Integrated Circuit (IC) could work loose. The fault finding guides in paragraph 6-3 and Table E-2 in Appendix E, show the resulting variety of failure modes. It is recommended that all IC's be confirmed to be fully seated before troubleshooting on the system begins.

d. Electrostatic Discharge

Electrostatic discharge can damage the IC's used in the electronics unit. It is essential that the user ensure he/she is at ground potential before removing or handling the processor board or the IC's used on it.

6-3 SYSTEM TROUBLESHOOTING

The status line of the GUI equipped IFT will display one of ten conditions. The system status displays will be displayed one at a time in priority sequence, as indicated in Table 6-1.

Table 6-1. IFT Status Codes

Off	<p>Heater power has been turned OFF by the electronics. The display shows 0% O₂. Several conditions may cause the OFF status:</p> <ol style="list-style-type: none"> 1. The cell heater temperature is below -50°C. The thermocouple wires may be reversed. 2. The cell temperature is more than 70°C above the set point. The heater is out of control. The triac module may have failed. 3. The cell heater thermocouple voltage has remained within ± 1.5 mV for more than 4 minutes. The thermocouple may be shorted. 4. The AD590 voltage is below 50.0 mV (50K or -223°C). The AD590 is not connected. 5. The AD590 voltage is above 363 mV (363K or 90°C). If HPS is used with IFT, then IFT interconnect board has JM1 in position connecting two AD590s in parallel.
PrbEr	The probe is disconnected or cold, or leads are reversed.
HtrEr	There is a fault within the heater system. The heater temperature is more than $\pm 25^\circ\text{C}$ from the set point. When the unit is first turned ON, HtrEr is normal. The heater may take 0.5 to 1.0 hours to warm up.
InCal	The system is currently undergoing calibration. If Output Tracks is set to YES, the output will show changing O ₂ values. If Output Tracks is set to NO, the output will hold the pre-calibration value.
LowO ₂	The measured O ₂ value is below the low O ₂ alarm limit. The problem may be in the probe or the process.
HiO ₂	The measured O ₂ value is above the high O ₂ alarm limit. The problem may be in the probe or the process.
NoGas	<p>Test gas pressure is too low. Pressure switches are set to trigger this alarm at 12 to 16 psig (83 to 110 kPa gage). Test gas regulators are usually set at 20 to 25 psig (138 to 172 kPa gage). Possible causes are:</p> <ol style="list-style-type: none"> 1. At least one test gas pressure switch is open. 2. A test gas cylinder is empty. 3. There is an MPS or piping failure. 4. If MPS is not connected, CALRET and NOGAS signals should be jumpered on the interconnect board.
CalEr	<p>An error occurred during the last calibration. The error may be one of the following:</p> <ol style="list-style-type: none"> 1. The new calculated slope value is outside the range 34.5 to 57.6 mV/decade. 2. The new calculated constant value is outside the range +20.0 to -20.0 mV. 3. The test gas pressure switch opened during calibration. <p>Ensure that the proper test gases are being used, and that the gas flows are set properly. Refer to Appendix D for additional MPS troubleshooting information.</p>
ResHi	The resistance calculated during the last good calibration was greater than the High Resistance Alarm limit set in the calibration setup. The resistance limit may be set wrong, or there is a problem with the probe.
Ok	Operation appears to be normal.
(blank screen)	A possible failure within the IFT. Check the LED on the microprocessor board to help isolate problems. See IFT Problem in the troubleshooting tables.

6-4 HEATER PROBLEM

For all heater troubleshooting, allow at least 30 minutes for the operating temperature to stabilize. After the warmup period, observe the system status and the voltages of the cell TC and the cold junction AD590. For heater related problems:

a. The status line may read: HtrEr or OFF.

b. The displayed O₂ value will read 0%.

c. Cell TC voltages will vary from normal. These voltages are found by accessing the proper menu. In the IFT, use the DIAG-NOSTIC DATA sub-menu of the PROBE DATA menu.

Refer to Table 6-2 to troubleshoot heater related problems.

Table 6-2. Heater Troubleshooting

Problem	Cause	Corrective Action
Status is <i>HtrEr</i> or <i>OFF</i>. Cell TC < 28.4 mV. Cold Junction 273 to 330 mV (normal). O₂ Display = 0%		<ol style="list-style-type: none"> 1. Blown fuse or faulty wiring. Check all fuses and wiring for continuity and repair as needed. Verify that input power jumpers are installed correctly. Check jumpers for proper configuration in IFT and HPS if used. 2. Heater failure. In HPS with power OFF, check heater resistance at J2, terminals R/H. For 44 V heater, resistance should be 11 to 14 ohms. For 115 V heater, resistance should be 67 to 77 ohms. Check wiring, and replace heater if needed. Heater resistance can also be checked at the probe junction box: <ul style="list-style-type: none"> • 44 V heater: terminals 7 and 8 should measure 11 to 14 ohms. • 115 V heater: terminals 5 and 6 should measure 67 to 77 ohms. (Terminals 6 to 7 and 6 to 8 should be open circuits.) 3. Triac open. Check the triac. Repair as needed. 4. Electronics failure. First check and repair all related wiring. Check and repair electronics as needed. 5. Missing insulation around heater. Check that insulation is in place and undamaged. Repair or replace insulation as needed.

Table 6-2. Heater Troubleshooting (continued)

Problem	Cause	Corrective Action
Status is <i>HtrEr</i> or <i>OFF</i>.		
Cell TC > 28.4 mV.		
Cold Junction 273 to 330 mV (normal).		
O₂ Display = 0%		
	1. Triac failure.	Check the triac. Repair as needed.
	2. Wrong TC set point.	Check electronics manual and verify the set point; typically 1356°F (736°C).
	3. Wrong heater voltage selected. HPS voltage jumpers setup wrong.	For 44 V heater, make sure JM7 is installed and JM8 is removed. For 115 V heater, JM7 is removed and JM8 is installed. The 115 V heater has an identifying stainless steel tag attached in the junction box.
Status is <i>HtrEr</i> or <i>OFF</i>.		
Cell TC < 28.4 mV.		
Cold Junction < 273 mV.		
O₂ Display = 0%		
	1. Wiring error, thermocouple wires reversed.	Verify TC wiring at junction box terminal and electronics. The yellow chromel line connects to terminal 3. The red alumel line connects to terminal 4. Trace line through the HPS (if used) and the electronics. Reverse wires if needed.
	2. Faulty thermocouple. At a cold junction reference of 77°F (25°C), the probe TC should read about 29.3 mV.	Replace faulty thermocouple.
	3. Faulty AD590. At normal ambient temperatures, cold junction sensor should be 273 to 330 mV.	Replace faulty sensor.
Status is <i>HtrEr</i> or <i>OFF</i>.		
Cell TC = -40 mV.		
Cold Junction 273 to 330 mV (normal).		
O₂ Display = 0%		
	1. Faulty thermocouple connection or open.	Verify TC wiring at junction box terminal and electronics. The yellow chromel line connects to terminal 3. The red alumel line connects to terminal 4. Trace line through the HPS (if used) and the electronics. Repair connection or wiring as needed.
	2. Thermocouple fault. At a cold junction reference of 77°F (25°C), the probe TC should read about 29.3 mV.	Replace faulty thermocouple.

6-5 CELL PROBLEM

For cell troubleshooting, as in heater problems, you should allow at least 30 minutes for operating temperature to stabilize. After this warmup period, observe the system status and cell voltage. If the heater is working, troubleshoot the cell. If the heater is not working, refer to Heater Problem, paragraph 6-4.

- The status line may read: Low O₂, Hi O₂, CalEr, ResHi.
- Access voltage values in the proper menu. Use the DIAGNOSTIC DATA sub-menu of the PROBE DATA menu.

- The displayed O₂ value will read 0% to 99%.
- It may be helpful to observe the calibration status and parameters from the last calibration: Slope, Constant, and Cell Resistance. In the CALIBRATE menu, VIEW CONSTANTS shows previous calibration values, and CALIBRATION STATUS shows the latest values. If these values appear out of range, perform a calibration before troubleshooting the cell.

Refer to Table 6-3 to troubleshoot cell related problems.

Table 6-3. Cell Troubleshooting

Problem	Cause	Corrective Action
Status is LowO₂. Cell mV = -127 mV.		<ol style="list-style-type: none"> 1. Faulty cell connection or open. If the cell circuit is open, the cell output will show about -127 mV. Check cable connection between the probe and the electronics. Check that the probe spring presses the contact pad firmly onto the cell. Repair or replace faulty wires, spring, or connectors. 2. Electronics fault. Cell output is good, and the input to the electronics is good. Check the electronics package. In an IFT, replace the microprocessor or interface board as needed. In a CRE, replace the DPI board if needed.
Status is ResHi or CalEr. Cell mV = -20 to 120 mV (normal).		<ol style="list-style-type: none"> 1. Test gas flow not 5 scfh (2.4 L/min). Check test gas flow and related piping. Rotameter should show 5 scfh. Adjust needle valve for correct flow rate. 2. Incorrect test gas. Confirm labels on test gas bottles are correct. Confirm High Gas and Low Gas values agree with labels on test gas bottles. (Refer to menu map — SETUP-CALIBRATION, High Gas, Low Gas.) Check all ports, cylinders, and gas lines for proper hookup. Change piping if necessary. Label pipes for reference.

Table 6-3. Cell Troubleshooting (continued)

Problem						
Cause						
Corrective Action						
Status is ResHi or CalEr.						
Cell mV = -20 to 120 mV (normal) (continued).						
1. Reference air contamination (oil/water). Clean or replace lines and valves as needed.						
2. Cell leads reversed. Check cell signal wiring from probe junction box to electronics, and correct wiring if needed.						
3. Reference/test gas lines reversed. Switch piping as needed.						
4. Diffusion element fault. Diffusion element cracked, broken, missing, or plugged. Replace diffuser or snubber as needed. Diffusers are disposable because it is difficult to clean a diffuser and know the tiny pores are open. A flow and pressure test with a manometer is possible but usually not practical. To clean a snubber, blow off surface dirt with pressurized air and clean the unit in an ultrasonic bath.						
5. Faulty cell. Low sensor cell output when test gas is applied. If test gas flow is good and there is low cell signal, replace the cell, or call the SCAN line for assistance.						
Typical cell output:						
<table border="1"> <thead> <tr> <th style="text-align: left;"><u>Test Gas</u></th> <th style="text-align: left;"><u>mV</u></th> </tr> </thead> <tbody> <tr> <td>8.0%</td> <td>18 to 25</td> </tr> <tr> <td>0.4%</td> <td>76 to 86</td> </tr> </tbody> </table>	<u>Test Gas</u>	<u>mV</u>	8.0%	18 to 25	0.4%	76 to 86
<u>Test Gas</u>	<u>mV</u>					
8.0%	18 to 25					
0.4%	76 to 86					
6. Cell performance degraded from aging. Replace the sensor cell if its resistance has increased beyond 1 kOhm and the slope calculated during calibration has decreased lower than 40 mV/decade.						
7. Electronics fault. Cell output is good, and the input to the electronics is good. Check the electronics package. In an IFT, replace the microprocessor or interface board as needed. In a CRE, replace the DPI board if needed.						
Status is Res Hi.						
Cell mV = -120 to 20 mV.						
1. Cell leads reversed. Check cell signal wiring from probe junction box to electronics, and correct wiring if needed.						
2. Reference/test gas lines reversed. Switch piping as needed.						
3. Reference air (nitrogen). Confirm labels on test gas bottles are correct. 100% nitrogen must NOT be used as a zero gas because cell protection will engage and affect the O ₂ reading. Reference air should be clean, dry instrument air prepared from ambient air with 20.95% O ₂ .						

6-6 IFT PROBLEM

Refer to Table 6-4 to troubleshoot IFT related problems.

When an IFT problem is suspected, look at the LED on the microprocessor board. The LED may be OFF, ON, or flashing.

Table 6-4. IFT Troubleshooting

Problem	Cause	Corrective Action
IFT LED is OFF. IFT failure.	Fuse fault.	Check fuses on power supply board. Replace fuses as needed.
	1. Power fault.	Check line voltage. Correct or turn main power ON.
	2. Power supply fault.	Check voltage test points on the microprocessor board. Replace power supply board if needed.
	3. Microprocessor board fault.	Replace microprocessor board.
IFT LED is steady ON. Heater or cell wiring problem.	1. Faulty wiring.	Check thermocouple and heater wires and connections for continuity. Repair as needed.
	2. Jumpers set up wrong. JM1 on interconnect board, JM6 on microprocessor board, or JM9 and JM10 on power supply board are configured incorrectly.	Check that jumpers are set up as follows: <ul style="list-style-type: none"> • Without an HPS, JM1 and JM6 should be installed. • With a 115 V probe heater, JM9 is installed. • With a 44 V probe heater, JM10 is installed.
	3. Status line is "OFF".	Turn OFF IFT power and restart. If light stays ON and both wiring and jumpers are OK, then replace the microprocessor board.
Faulty GUI or LDP (IFT LED is Flashing).	1. Microprocessor is normal, but front panel indicators are not working properly.	Check connections to GUI or LDP, and repair or replace as needed.

6-7 MPS PROBLEM

MPS problems can occur with a status of C Err, R Hi, TGLow. The O₂ reading can be 0% to

99%, and probe data will be in the normal ranges. Consider two conditions, A and B.

Refer to Table 6-5 to troubleshoot problems with the MPS.

Table 6-5. MPS Troubleshooting

Problem
Cause
Corrective Action
<p>Status is NoGas. Cell mV is between -20 to 120 mV.</p> <ol style="list-style-type: none"> 1. Regulator or plumbing fault. The test gas pressure is low for the indicated probe [20 to 25 psig (138 to 172 kPa gage)]. Check test gas pressure [should be 20 psig (138 kPa gage)], regulator, and lines. Reset, repair, or replace the regulator as needed. If only one probe has low flow [less than 5 scfh (2.4 L/min)], check lines, needle valve, connectors, and MPS solenoid for that probe. 2. Test gas low. Replace empty test gas cylinder with full cylinder. Verify O₂ concentration. 3. Wiring fault. Confirm proper wiring and continuity between MPS and electronics. Repair as needed. 4. Pressure switch fault. Pressure switch is factory set at 16 psig (68.9 kPa gage). Set test gas regulator pressure to 20 psig (138 kPa gage) to avoid nuisance alarms. Replace faulty switch with a new one if test gas supply is good. <p>Status is ResHi or CalEr. Cell mV is between -20 to 120 mV.</p> <p>The CalEr occurs when the slope calculated from the last calibration was out of range. CalEr can be caused by leaks, a faulty diffusor or sensor cell, erroneous test gas values, or not enough test gas time. Each test gas should be supplied for at least <u>three minutes</u>.</p> <ol style="list-style-type: none"> 1. Flowmeter set incorrectly. The flowmeter for each probe must be set individually. Flow should be 5 scfh (2.4 L/min). 2. Wiring fault. Confirm proper wiring and continuity between MPS and electronics. 3. Piping fault. Faulty gas line or regulator. Check gas line, valves, and regulators for blockage or corrosion. Repair or replace as needed. 4. Solenoid fault. Verify nominal 24 VDC at HI GAS, LOW GAS, IN CAL, and CAL RET connections. Voltages should drop to about 4 VDC. If voltage is present but solenoid does not work, replace the solenoid. 5. Termination board fault. Verify 24 VDC at J11 on termination board. Repair or replace termination board or connectors as needed. 6. Power supply fault. Verify power supply fuses and output are good and that line voltage is present at J1. Repair or replace the power supply as needed. 7. Power fault. Check fuses, mains, and circuit breakers. Repair or replace as needed.

World Class 3000

6-8 PERFORMANCE PROBLEM (PROCESS RESPONSE IS SUSPECT)

O₂ readings may not always agree with known process conditions. Such a discrepancy can be the first sign of a problem either in the process or the World Class 3000. The O₂ display will

read between 0 to 99%, but the reading may be unstable. The status line may read OK, and PROBE DATA voltages may read normal.

Refer to Table 6-6 to troubleshoot performance problems.

Table 6-6. Performance Problem Troubleshooting

Problem	Cause	Corrective Action
<p>Status is OK. Cell mV is -20 to 120 mV (normal). O₂ display is stable but not expected value.</p>	<p>Such a condition occurs during various kinds of leaks and data output faults.</p>	<ol style="list-style-type: none"> 1. Mounting flange leak. Reseal the flange, and tighten bolts properly. 2. Test gas line leak. Since the test gas line is under positive pressure, the line can be tested with a bubbling liquid such as SNOOP™. Repair or replace as needed. 3. Silicon hose break. Leaks may occur in the silicon rubber hose in the probe junction box. Replace hose. 4. Air ingress from leaky duct. Check condition of duct, gas lines, and fittings. If duct has air ingress upstream of probe, re-site the probe or fix the leak. 5. Analog output or recorder fault. Measure analog output in voltage or milliamps as set up on the analog output board and software. If analog output is not in range, replace the analog output board in a CRE or the micro-processor board in an IFT. Check recorder function, and repair as needed. 6. Random spiking of the analog output to 0 mA dc. Check the power supply voltage. If suspect, replace the power supply in the CRE or the power supply board in the IFT.
<p>Status is OK. Cell mV is -20 to 120 mV (normal). O₂ display is unstable.</p>	<ol style="list-style-type: none"> 1. Process variations. Analyze the process for even flows of gases or materials. Check the operation of dampers and control valves. Repair process devices, procedures, and flows as needed. Depending on the process, some variation may be normal. 2. Pad to cell connection fault. Check pad and contact for cleanliness, and clean as needed. Check spring tension, and replace as needed. 3. Grounding fault. Check all wiring for continuity and connections for cleanliness and lack of corrosion. Repair as needed. 4. Improper line voltage. Check line voltage circuit for proper polarity and/or "hot" and "neutral" circuitry. 	

SECTION 7 RETURN OF MATERIAL

7-1 If factory repair of defective equipment is required, proceed as follows:

- a.** Secure a return authorization number from a Rosemount Analytical Sales Office or representative before returning the equipment. Equipment must be returned with complete identification in accordance with Rosemount instructions or it will not be accepted.

In no event will Rosemount be responsible for equipment returned without proper authorization and identification.

- b.** Carefully pack defective unit in a sturdy box with sufficient shock absorbing material to insure that no additional damage will occur during shipping.

c. In a cover letter, describe completely:

1. The symptoms from which it was determined that the equipment is faulty.
2. The environment in which the equipment has been operating (housing, weather, vibration, dust, etc.).
3. Site from which equipment was removed.
4. Whether warranty or nonwarranty service is requested.

5. Complete shipping instructions for return of equipment.

6. Reference the return authorization number.

- d.** Enclose a cover letter and purchase order and ship the defective equipment according to instructions provided in Rosemount Return Authorization, prepaid, to:

Rosemount Analytical Inc.
RMR Department
1201 N. Main Street
Orrville, Ohio 44667

If warranty service is requested, the defective unit will be carefully inspected and tested at the factory. If failure was due to conditions listed in the standard Rosemount warranty, the defective unit will be repaired or replaced at Rosemount's option, and an operating unit will be returned to the customer in accordance with shipping instructions furnished in the cover letter.

For equipment no longer under warranty, the equipment will be repaired at the factory and returned as directed by the purchase order and shipping instructions.

SECTION 8 APPENDICES

APPENDIX A. WORLD CLASS 3000 OXYGEN ANALYZER (PROBE)

APPENDIX B. HPS 3000 HEATER POWER SUPPLY

APPENDIX D. MPS 3000 MULTIPROBE CALIBRATION GAS SEQUENCER

APPENDIX E. IFT 3000 INTELLIGENT FIELD TRANSMITTER

APPENDIX J. HART COMMUNICATOR MODEL 275D9E IFT 3000 APPLICATIONS

NOTE: NOT ALL PARTS SHOWN ARE AVAILABLE FOR PURCHASE SEPARATELY. FOR LIST OF AVAILABLE PARTS, SEE TABLE A-3.

1. Heater, Strut, and Backplate Assembly
2. Diffusion Assembly
3. Retainer Screw
4. Cell and Flange
5. Corrugated Seal
6. Probe Tube Assembly
7. Screw
8. Washer
9. Cover Chain Screw
10. Cover Chain
11. Probe Junction Box Cover
12. Cover Gasket
13. Wiring Diagram
14. O-Ring
15. Terminal Block Screws
16. Terminal Block
17. Terminal Block Marker
18. Terminal Block Mounting Plate

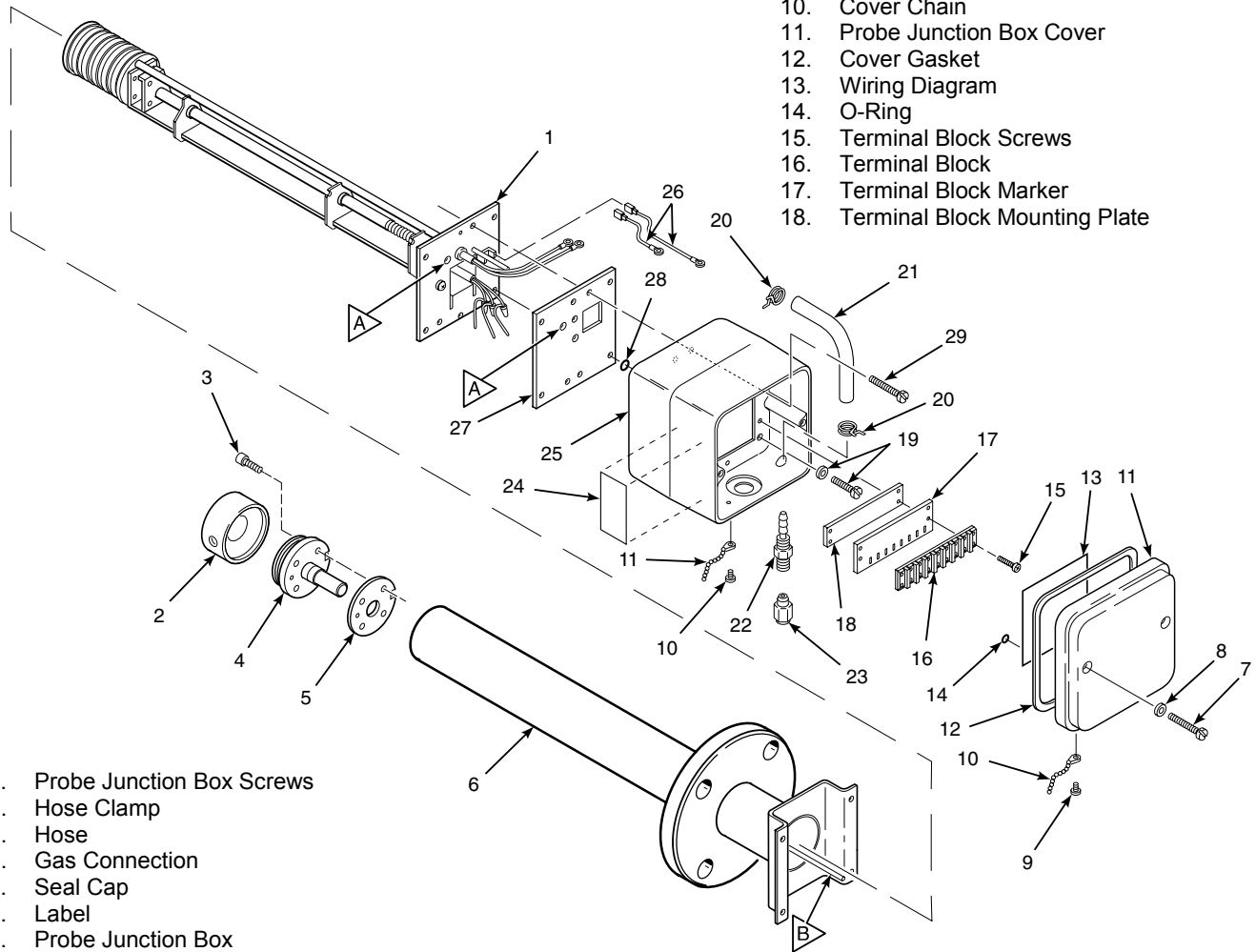

19. Probe Junction Box Screws
20. Hose Clamp
21. Hose
22. Gas Connection
23. Seal Cap
24. Label
25. Probe Junction Box
26. Ground Wires
27. Insulating Gasket
28. Washer
29. Screw

NOTE: ITEM **B**, CALIBRATION GAS TUBE, FITS INTO HOLES **A** WHEN PROBE IS ASSEMBLED.

21240005

Figure A-1. Oxygen Analyzer (Probe) Exploded View

APPENDIX A, REV. 3.8 WORLD CLASS 3000 OXYGEN ANALYZER (PROBE)

DESCRIPTION

WARNING

Read the "Safety instructions for the wiring and installation of this apparatus" at the front of this Instruction Bulletin. Failure to follow the safety instructions could result in serious injury or death.

A-1 OXYGEN ANALYZER (PROBE) - GENERAL

The Oxygen Analyzer (Probe), Figure A-1, consists of three component groups: probe exterior, inner probe, and probe junction box, Figure A-2.

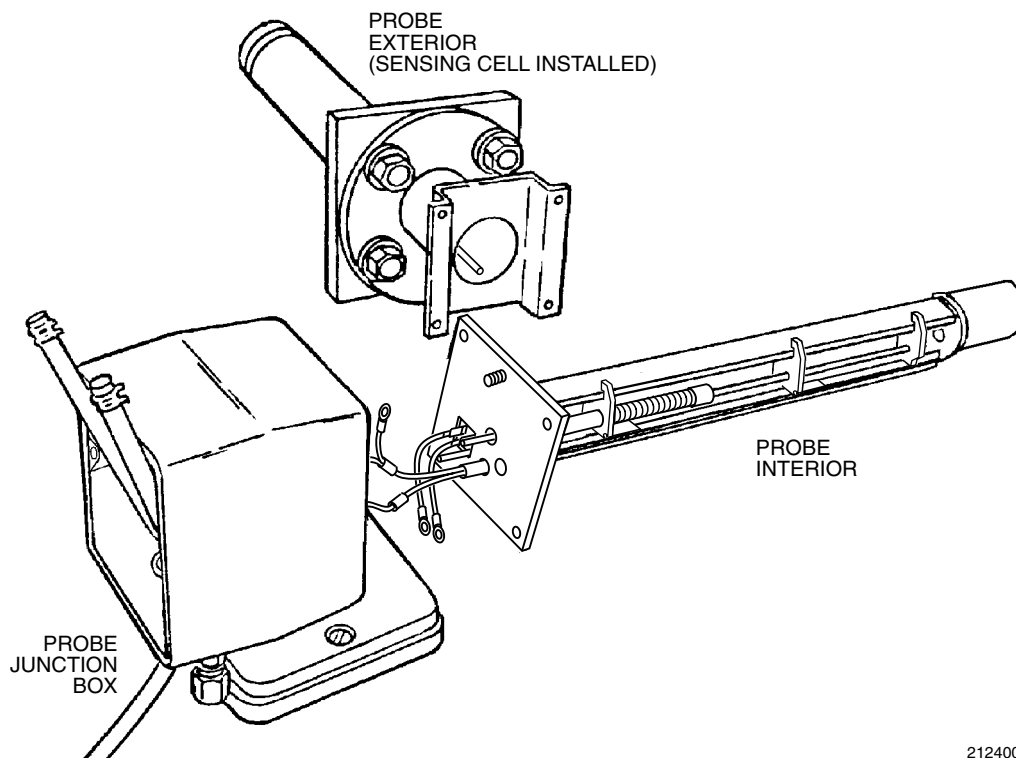

21240006

Figure A-2. Main Probe Components

Table A-1. Specifications for Oxygen Analyzing Equipment.^{1,2}

Probe lengths, nominal	18 inches (457 mm), 3 feet (0.91 m), 6 feet (1.83 m), 9 feet (2.74 m), or 12 feet (3.66 m), depending on duct dimensions
Temperature limits in process measurement area	50° to 1300°F (10° to 704°C)
Standard/current output.....	4-20 mA dc signal (factory set)
O ₂ indication (Digital display and analog output).....	0.1% O ₂ or ±3% of reading, whichever is greater using Rosemount calibration gases
System speed of response	less than 3 seconds (amplifier output)
Resolution sensitivity	0.01% O ₂ transmitted signal
HPS 3000 housing.....	NEMA 4X (IP56)
Probe reference air flow	2 scfh (56.6 L/hr) clean, dry, instrument quality air (20.95% O ₂), regulated to 5 psi (34 kPa)
Calibration gas mixtures	Rosemount Hagan Calibration Gas Kit Part No. 6296A27G01 contains 0.4% O ₂ N ₂ Nominal and 8% O ₂ N ₂ Nominal
Calibration gas flow	5 scfh (141.6 L/hr)
HPS 3000 Power supply.....	100/110/220 ±10% Vac at 50/60 Hz
HPS 3000 Power requirement.....	200 VA
HPS 3000 Ambient Operating Temperature	32° to 120°F (0° to 50°C)
Ambient operating temperature (Probe Junction Box)	300°F (150°C) max
Approximate shipping weights:	
18 inch (457 mm) package.....	55 pounds (24.97 kg)
3 foot (0.91 m) package.....	60 pounds (27.24 kg)
6 foot (1.83 m) package.....	65 pounds (29.51 kg)
9 foot (2.74 m) package.....	72 pounds (32.66 kg)
12 foot (3.66 m) package.....	78 pounds (35.38 kg)

¹All static performance characteristics are with operating variables constant.

²Equipment ordered utilizing this document as reference will be supplied to the USA standard design. Customers requiring the EEC standard design should request the EEC documentation and utilize its ordering data. Temperatures over 1000°F (537°C) may affect the ease of field cell replaceability.

A-2 PROBE ASSEMBLY EXTERIOR

Primary probe exterior components include a flange-mounted zirconium oxide cell, mounted on a tube assembly and protected by a snubber diffusion assembly.

a. Cell and Flange Assembly

The primary component in the cell and flange assembly, Figure A-3, is a yttria-stabilized zirconium oxide cell. It creates an electrical signal when the oxygen level on one side is out of balance with the oxygen level on the other side. This signal is proportional to the difference in oxygen levels.

b. Probe Tube Assembly

Four screws secure the cell and flange assembly, Figure A-3, to the probe tube assembly. When in place, the cell is inside the tube.

The tube assembly includes a flange which mates with a stack-mounted flange (shown attached to the probe flange in Figure A-2). Studs on the stack flange make installation easy. There is also a tube to carry calibration gas from the probe junction box to the process side of the cell during calibration.

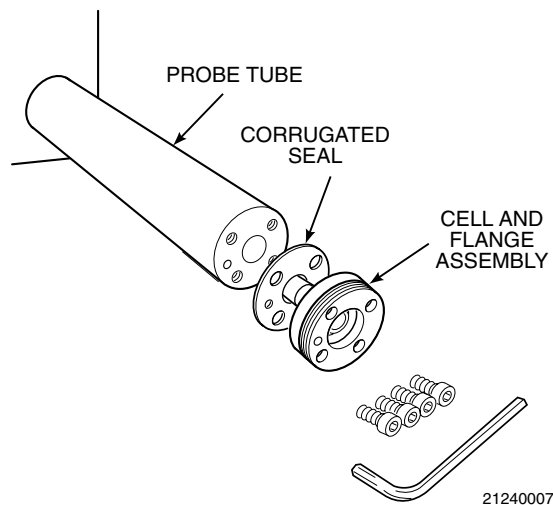

Figure A-3. Cell and Tube Assemblies

c. Snubber Diffusion Assembly

The snubber diffusion assembly protects the cell from heavy particles and isolates the cell from changes in temperature. The snubber diffusion assembly threads onto the cell and flange assembly. Pin spanner wrenches (probe disassembly kit 3535B42G01) are applied to holes in the snubber diffusion element hub to remove or install the snubber diffusion assembly.

An optional ceramic diffuser element and vee deflector, shown in Figure A-4, is available. The ceramic diffuser assembly is also available in a flame arresting version to keep heat from the cell from igniting flue gases.

Systems that use an abrasive shield require a special snubber diffusion assembly with a hub that is grooved to accept two dust seal gaskets. This special diffuser is available in both snubber and ceramic versions. See Probe Options, section A-6.

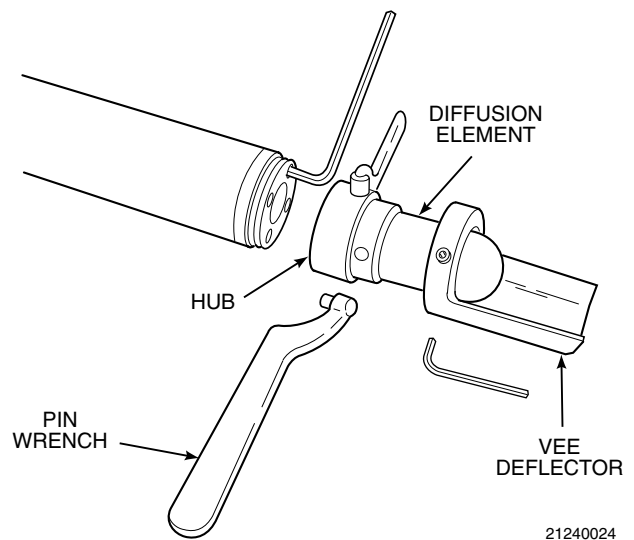

Figure A-4. Optional Ceramic Diffuser and Vee Deflector Assembly

d. Cell - General

The components which make up the cell are machined to close tolerances and assembled with care to provide accurate oxygen measurements. Any replacement requires attention to detail and care in assembly to provide good results.

WARNING

Failure to follow the instructions in this manual could cause danger to personnel and equipment. Read and follow instructions in this manual carefully.

The oxygen probe includes an inner electrode for the cell assembly. It consists of a platinum pad and a platinum/inconel composite wire which produces the cell constant offset voltage described in the Nernst equation.

With this pad and wire, the constant will be between -10 and +15 mV. The cell constant is noted in the calibration data sheet supplied with each probe.

Every probe should be calibrated and checked after repair or replacement of cell, pad and wire, heater, and thermocouple, or after disassembly of the probe.

A-3 INNER PROBE ASSEMBLY

The inner probe assembly, Figure A-5, consists of six main parts:

- a. Ceramic support rod with four holes running through the length. The holes serve as insulated paths for the cell signal wire and thermocouple wires.

- b. A heater that is helically wrapped on a quartz support cylinder and insulated.
- c. A chromel-alumel thermocouple which acts as the sensing element for the temperature controller. (Not visible in Figure A-5; located within ceramic support rod.)
- d. A platinum screen pad which forms electrical contact with the inner electrode of the electrochemical cell. (Not visible in Figure A-5; located at end of ceramic support rod.) The pad is attached to an inconel wire which carries the signal to the terminal strip.
- e. A V-strut assembly to give support to the inner probe assembly.
- f. A tube to carry reference air to the cell.

Turn to Service and Normal Maintenance, for repair procedures for probe components.

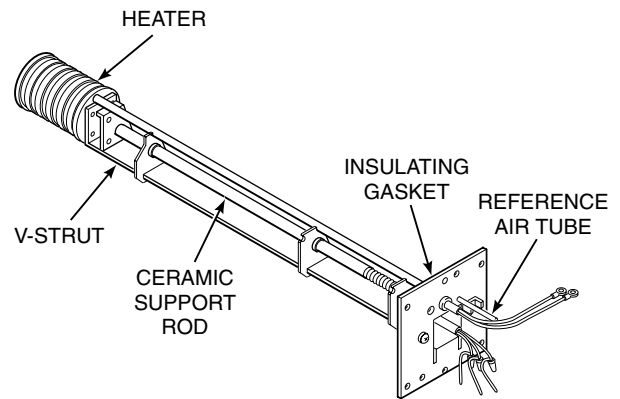

27270015

Figure A-5. Inner Probe Assembly

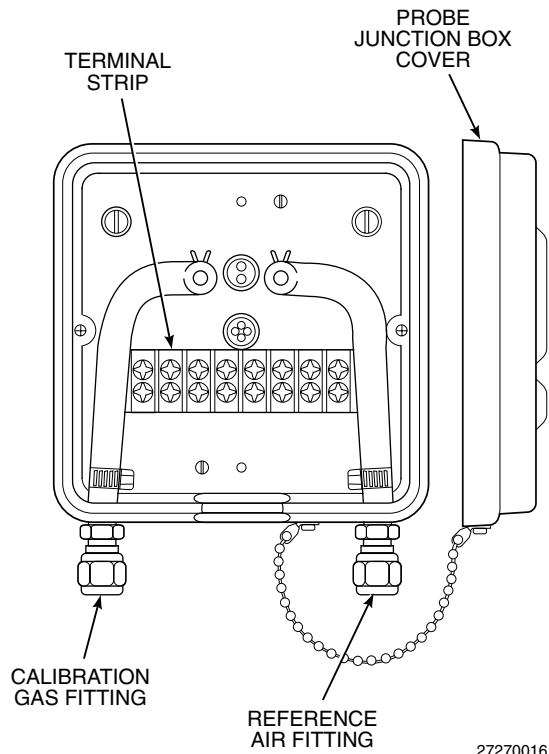

Figure A-6. Probe Junction Box

A-4 PROBE JUNCTION BOX

The probe junction box, Figure A-6, is positioned at the external end of the probe and contains a terminal strip for electrical connections and fittings for reference air and calibration gases. Fittings are for 0.250 inch stainless steel tubing on American units and 6 mm on European units. The calibration fitting has a seal cap which must remain in place except during calibration. A tubing fitting is also supplied to be used with the calibration gas supply during calibration.

If the calibration gas bottles will be permanently hooked up to the probe, a manual block valve is required at the probe (between the calibration fitting and the gas line) to prevent condensation of flue gas down the calibration gas line.

During operation and calibration, reference air is supplied through the reference air fitting to the reference side of the cell. This gives the system a known quantity of oxygen with which to compare the oxygen level in the process gas. Though ambient air can be used for this purpose, accuracy can only be assured if a reference air set is used.

During calibration, two gases of different known oxygen concentrations are injected one at a time through the calibration gas fitting. Stainless steel tubing delivers this gas to the process side of the cell. In a healthy cell, the difference in oxygen pressure from the process side to the reference side of the cell will cause a millivolt output proportional to the difference in oxygen levels. The electronics unit can use the two millivolt outputs caused by the two calibration gases for either automatic or semi-automatic calibration.

CAUTION

Do not attempt to remove a process gas sample through either gas fitting. Hot gases from the process would damage gas hoses in the probe junction box.

A-5 CABLE ASSEMBLY

The system uses a 7-conductor cable to connect the probe to the electronics package. Standard length for this cable is 20 feet (6 m), but lengths up to 150 feet (45 m) are available. The seven conductors include one shielded pair of wires for the cell millivolt signal, one shielded pair of type K wires for the thermocouple, and three individual 16-gauge wires for the heater and for ground. The assembled conductors are wrapped by a type K Teflon™ jacket and braided stainless steel shield. The Teflon™ and stainless steel jacketing is suitable for high temperature use. All metal shields are isolated at the probe end and connect by drain wires to ground at the electronics.

A-6 PROBE OPTIONS

a. Abrasive Shield Assembly

The abrasive shield assembly, Figure A-7, is a stainless-steel tube that surrounds the probe assembly. The shield protects the probe against particle abrasion and corrosive condensations, provides a guide for ease of insertion, and acts as a probe position support, especially for longer length probes. The abrasive shield assembly uses a modified diffusor and vee deflector assembly, fitted with dual dust seal packing.

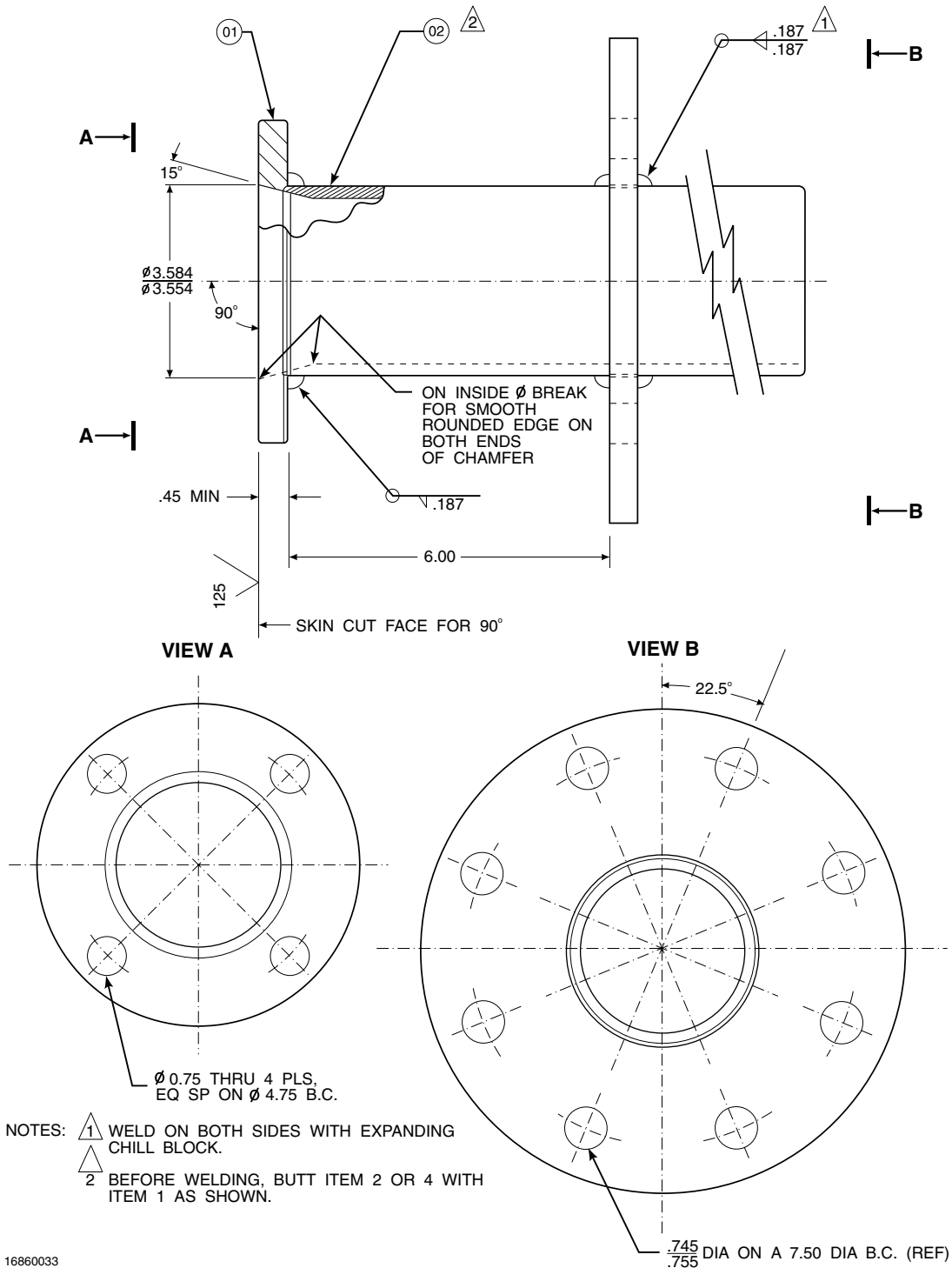
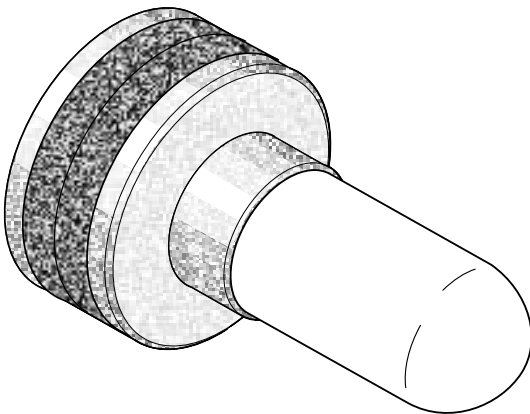

Figure A-7. Abrasive Shield Assembly

NOTE

In highly abrasive applications, rotate the shield 90 degrees at normal service intervals to present a new wear surface to the abrasive flow stream.



P0010

Figure A-8. Ceramic Diffusion/Dust Seal Assembly

These modified diffusion and vee deflector assemblies are available in standard, Figure A-8, and flame arrester version, Figure A-9.

b. Ceramic Diffusion Assembly

The ceramic diffusion assembly, Figure A-10, is the traditional design for the probe. Used for over 25 years, the ceramic diffusion assembly provides a greater filter surface area for the probe.

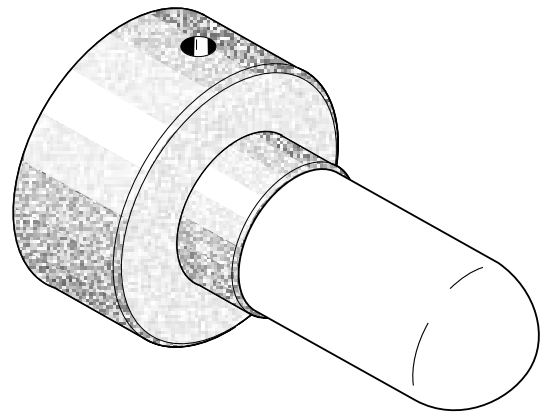

19280010

Figure A-10. Ceramic Diffusion Assembly

c. Flame Arrester Diffusion Assembly

Where a high concentration of unburned fuel is present in the exhaust gases, a flame arrester diffusion assembly, Figure A-9 and Figure A-11 is recommended.

The flame arrester diffusion assembly includes a set of baffles between the cell and the stack gases. This keeps 1500°F (816°C) cell temperatures from igniting unburned fuel in the stack.

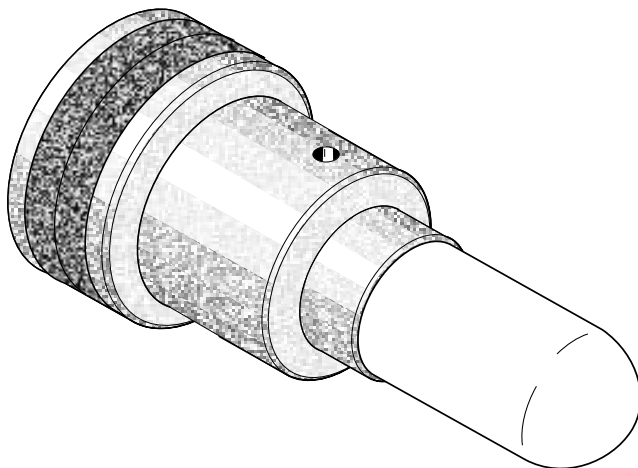

P0011

Figure A-9. Flame Arrester Diffusion/Dust Seal Assembly

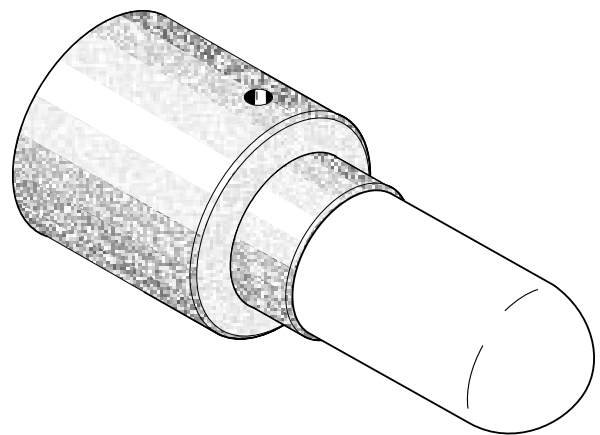

P0012

Figure A-11. Flame Arrester Diffusion Assembly

d. Snubber Diffusion/Dust Seal Assembly

The snubber diffusion/dust seal assembly, Figure A-12, is used in applications where an abrasive shield is to be used with a snubber type diffusion element. The dust seal consists of two rings of packing to prevent abrasive dust from collecting inside the abrasive shield.

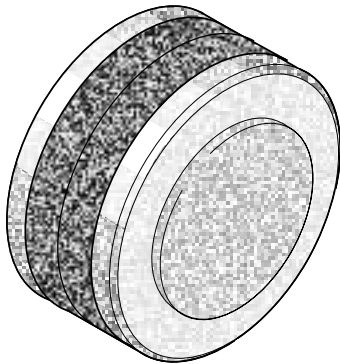

Figure A-12. Snubber Diffusion/Dust Seal Assembly

e. Cup-Type Diffusion Assembly

The cup-type diffusion assembly, Figure A-13, is used in high-temperature applications where frequent diffusion element plugging is a problem. This element may be used with or without an abrasive shield.

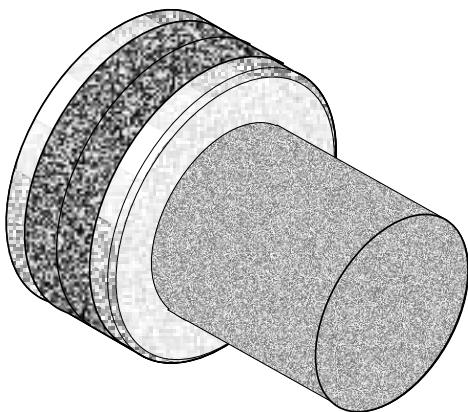

Figure A-13. Cup-Type Diffusion/Dust Seal Assembly

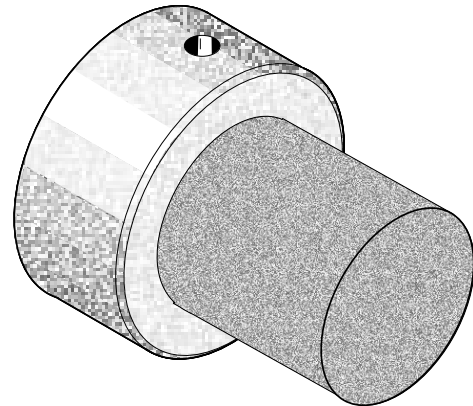

Figure A-14. Cup-Type Diffusion Assembly

f. Bypass Probe Options

For processes where the flue gas exceeds the maximum allowable temperature of 1300°F (704°C) a bypass sensor package can be employed. The bypass system uses an 18 inch (457 mm) or 3 foot (0.92 m) probe mounted externally on the stack or duct. The process or exhaust gases are directed out to the probe through a passive sampling system using inconel tubes. Flue gas flow induces the movement of gases into, through, and out of the bypass unit. The bypass arrangement does not require the use of aspiration air and the gas which flows past the probe is returned to the stack or duct.

The bypass probe package is normally used for process temperatures of 1300°F (704°C) to 2000°F (1094°C). A higher temperature version of the bypass provides for operation at temperatures up to 2500°F (1372°C). In this version the pick up tubes are made of a special high-temperature alloy.

Overall dimensions and mounting details of the American and European bypass systems are shown in Figure A-15.

g. Probe Mounting Jacket Options

A probe mounting jacket option is available to allow the probe to operate at temperatures of up to 2000°F (1095°C). A separate instruction bulletin is available for this option.

- NOTES:
1. REFERENCE AIR SUPPLY CONNECTION BITE TYPE FITTING (PARKER CPI) FOR 0.250 O.D. TUBING. 2 SCFH AT 3 PSIG MAX. CLEAN DRY AIR REQUIRED. FITTING IS LOCATED ON FAR SIDE.
 2. CALIBRATION AND PURGE GAS CONNECTION. BITE TYPE FITTING (PARKER CPI) 10 SCFH AT 32 PSIG MAX. CALIBRATION GAS REQUIRED.
 3. LAG TO ENSURE GAS TEMPERATURE DOES NOT GO BELOW DEW POINT OR EXCEED 500°C.
 4. INSTALL WITH ANALYZER IN A VERTICALLY DOWNWARDS DIRECTION ONLY.
 5. FLUE GAS OPERATING TEMPERATURE RANGE 1200° TO 1800°F (650° TO 980°C).
 6. RECOMMENDED TWO INCH THK INSULATION. THERMAL CONDUCTIVITY K EQUALS 0.5 FOR INSULATION.
 7. DIMENSIONS ARE IN INCHES WITH MILLIMETERS IN PARENTHESES.

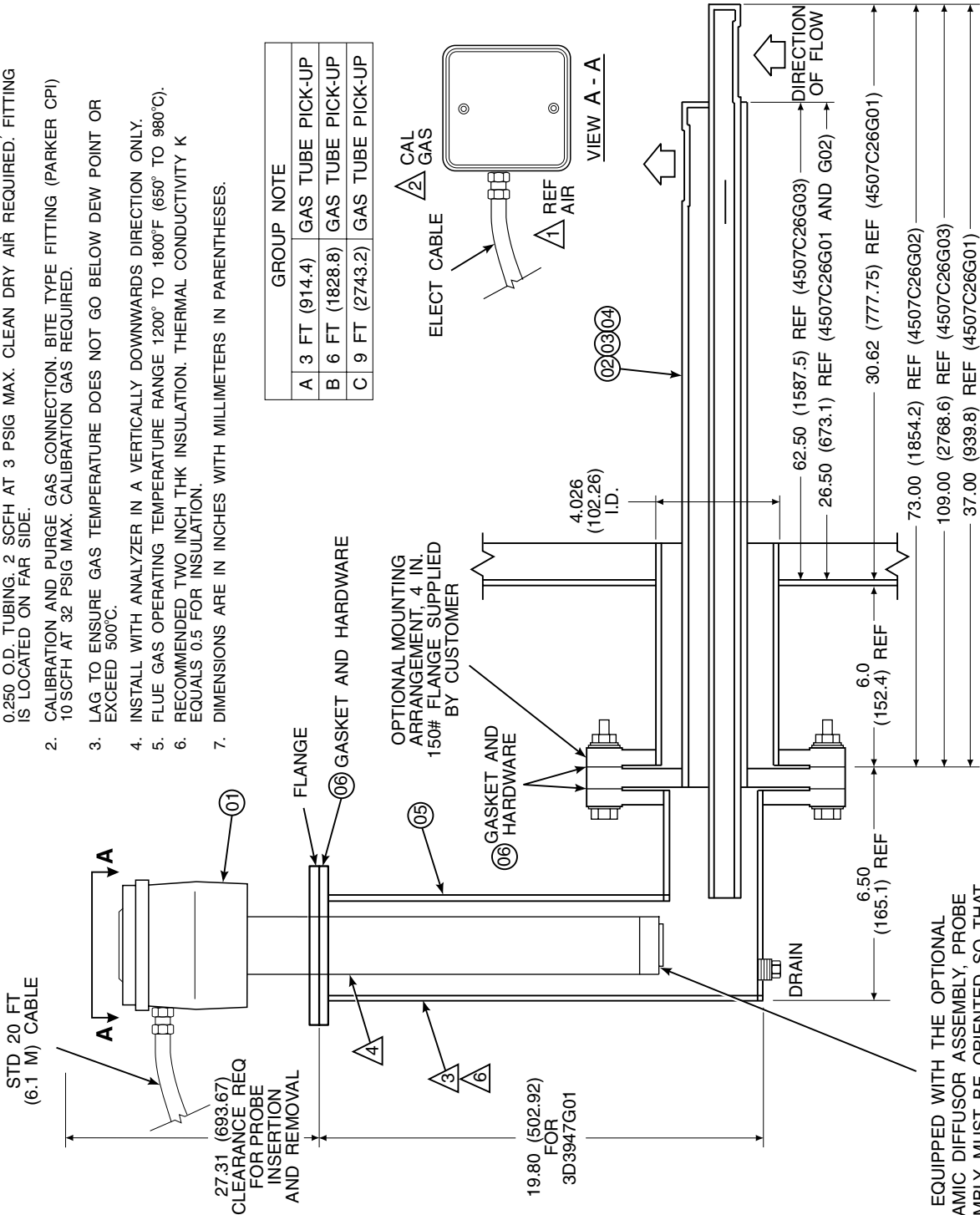

IF EQUIPPED WITH THE OPTIONAL CERAMIC DIFFUSOR ASSEMBLY, PROBE ASSEMBLY MUST BE ORIENTED SO THAT VEE SHIELD IS SQUARE TO GAS FLOW.

Figure A-15. Bypass Probe Option (Sheet 1 of 3)

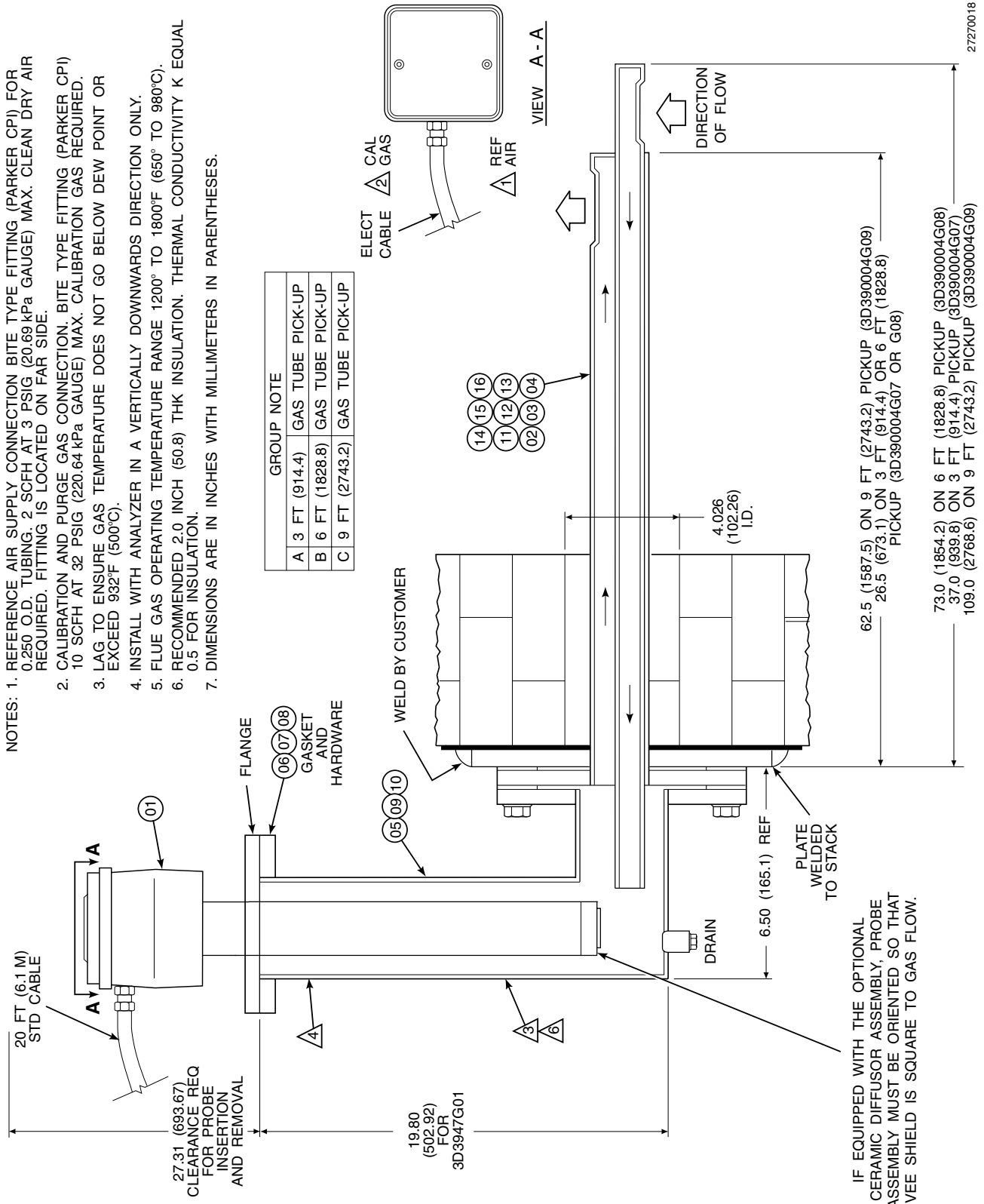

Figure A-15. Bypass Probe Option (Sheet 2 of 3)

PARTS LIST				FLANGE STYLE	ANSI			JIS			DIN		
PARTS LIST UNITS: INCHES				GROUP NOTE	A	B	C	A	B	C	A	B	C
NOTE	PART NAME	DEFINER	SIZE-REFERENCE INFORMATION	MAIL CODE PART NUMBER OR REF DWG	3D39004 GROUP								
ITEM					G01	G02	G03	G04	G05	G06	G07	G08	G09
01	WORLD CLASS 3000	DWG	PROBE 18 IN.	ORDER FROM MATRIX									
02	GAS PICK-UP	DWG	3 FT	4507C26G01	1								
03	GAS PICK-UP	DWG	6 FT	4507C26G02		1							
04	GAS PICK-UP	DWG	9 FT	4507C26G03			1						
05	ANALYZER HOUSING	DWG	FOR WORLD CLASS 3000 ANSI	3D39005G01	1	1	1						
06	MTG HARDWARE	DWG	FOR ANSI FLANGE	3535B58G01	1	1	1						
07	MTG HARDWARE	DWG	FOR JIS	3535B58G03				1	1	1			
08	MTG HARDWARE	DWG	FOR DIN	3535B58G05							1	1	1
09	ANALYZER HOUSING	DWG	FOR JIS	3D39005G02				1	1	1			
10	ANALYZER HOUSING	DWG	FOR DIN	3D39005G03							1	1	1
11	GAS PICK-UP	DWG	FOR JIS 3 FT	4507C26G04				1					
12	GAS PICK-UP	DWG	FOR JIS 6 FT	4507C26G05					1				
13	GAS PICK-UP	DWG	FOR JIS 9 FT	4507C26G06						1			
14	GAS PICK-UP	DWG	FOR DIN 3 FT	4507C26G07							1		
15	GAS PICK-UP	DWG	FOR DIN 6 FT	4507C26G08								1	
16	GAS PICK-UP	DWG	FOR DIN 9 FT	4507C26G09									1

Extended Temperature By-Pass Arrangements (2400°F; 1300°C)

PART NO.	GROUP CODE	DESCRIPTION
1U0571	G01	3' By-pass Package with ANSI bolt pattern.
1U0571	G02	6' By-pass Package with ANSI bolt pattern.
1U0571	G03	9' By-pass Package with ANSI bolt pattern.
1U0571	G04	3' By-pass Package with JIS bolt pattern.
1U0571	G05	6' By-pass Package with JIS bolt pattern.
1U0571	G06	9' By-pass Package with JIS bolt pattern.
1U0571	G07	3' By-pass Package with DIN bolt pattern.
1U0571	G08	6' By-pass Package with DIN bolt pattern.
1U0571	G09	9' By-pass Package with DIN bolt pattern.

Figure A-15. Bypass Probe Option (Sheet 3 of 3)

PROBE TROUBLESHOOTING

A-7 OVERVIEW

The probe troubleshooting section describes how to identify and isolate faults which may develop in the probe assembly.

WARNING

Install all protective equipment and safety ground leads after troubleshooting. Failure to replace covers and ground leads could result in serious injury or death.

1. The system does not respond to changes in the oxygen concentration.
2. The system responds to oxygen changes but does not give the correct indication.
3. The system does not give an acceptable indication of the value of the oxygen calibration gas being applied during calibration.
4. The system takes a long time to return to the flue gas value after the calibration gas is turned off.

A-8 PROBE TROUBLESHOOTING

a. Probe Faults

Listed below are the four symptoms of probe failure.

- b. Table A-2 provides a guide to fault finding for the above symptoms.
- c. Figure A-16 and Figure A-17 provide an alternate approach to finding probe related problems.

Table A-2. Fault Finding

Symptom	Check	Fault	Remedy
1. No response to oxygen concentration change when: Heater is cold and TC mV output is less than set point	Thermocouple continuity	Thermocouple failure	Replace thermocouple or return probe to Rosemount.
	Heater cold resistance to be 11 ohm to 14 ohm	Heater failure	Replace heater or return probe to Rosemount.
	Triac O/P to heater	Failure of electronics	Check HPS and electronics package.
	Recorder chart	Recorder failure	See Recorder Instruction Manual.
Heater is hot and T/C mV output is at set point ± 0.2 mV	Cell mV input to electronics <u>and</u> cell mV at probe junction box	No cell mV at probe when calibration gas applied	Replace cell or return probe to Rosemount.
		Probe cell mV OK but no input to electronics	Check out cable connection.
		Cell mV satisfactory both at probe junction box and input to electronics - failure of electronics	Check electronics package.

Table A-2. Fault Finding (Continued)

Symptom	Check	Fault	Remedy
2. System responds to oxygen concentration changes <u>but</u> does not give correct indication Good response, with incorrect indication	Recorder or remote indicator	Calibration error	Recalibrate recorder or indicator. Reference Recorder Instruction Manual.
	System calibration	Calibration error	Recalibrate system.
	Probe mounting and condition of duct	Air ingress into duct	Stop air leaks or resite probe.
	Cell mV input to electronics	Failure of electronics	Check electronics package.
3. System does not give accurate indication of applied calibration gas	Calibration gas input port	Blocked port	Clean port. If the flue gas is condensing in the calibration gas line, insulate the back of the probe. Make sure that the calibration gas line is capped between calibrations, or a check valve is installed.
	Ceramic diffusion element	Diffusion element cracked, broken, or missing	Replace diffusion element.
4. System takes a long time to return to flue gas value after calibration gas is turned off	Diffusion element	Plugged diffusion element	Change diffusion element or snubber diffusion element.
5. Probe passes calibration, but appears to read high.	Check calibration gas fitting.	Leak in gasket, or calibration gas fittings or tubing.	Repair leak.
	Check calibration gas hoses or tubing.	Leak in calibration gas hose or tubing.	Repair hose or tubing.
	Cell flange corrugated seal.	Leaking seal.	Replace seal.
	If equipped with an abrasive shield, check flange mounting gasket.	Leaking gasket.	Replace gasket.
6. Probe passes calibration, but appears to read low.	Flow calibration gas to the probe until reading stabilizes. Shut off calibration gas and note the time required to return to process gas values. Time should be <20 sec. (<40 sec. for hazardous area probes).	Plugged diffuser element from high process particulate may cause a calibration shift.	Replace diffuser.

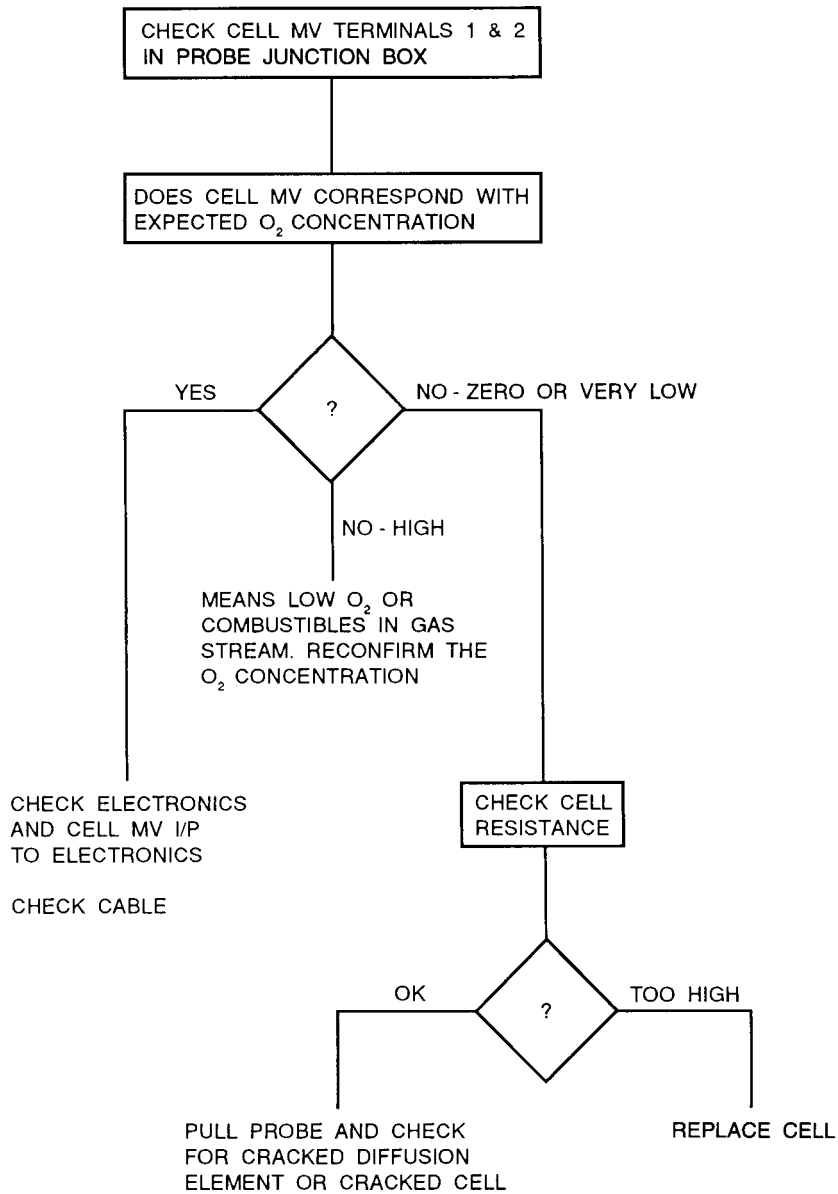

Figure A-16. Flowchart of Probe Related Problems, #1

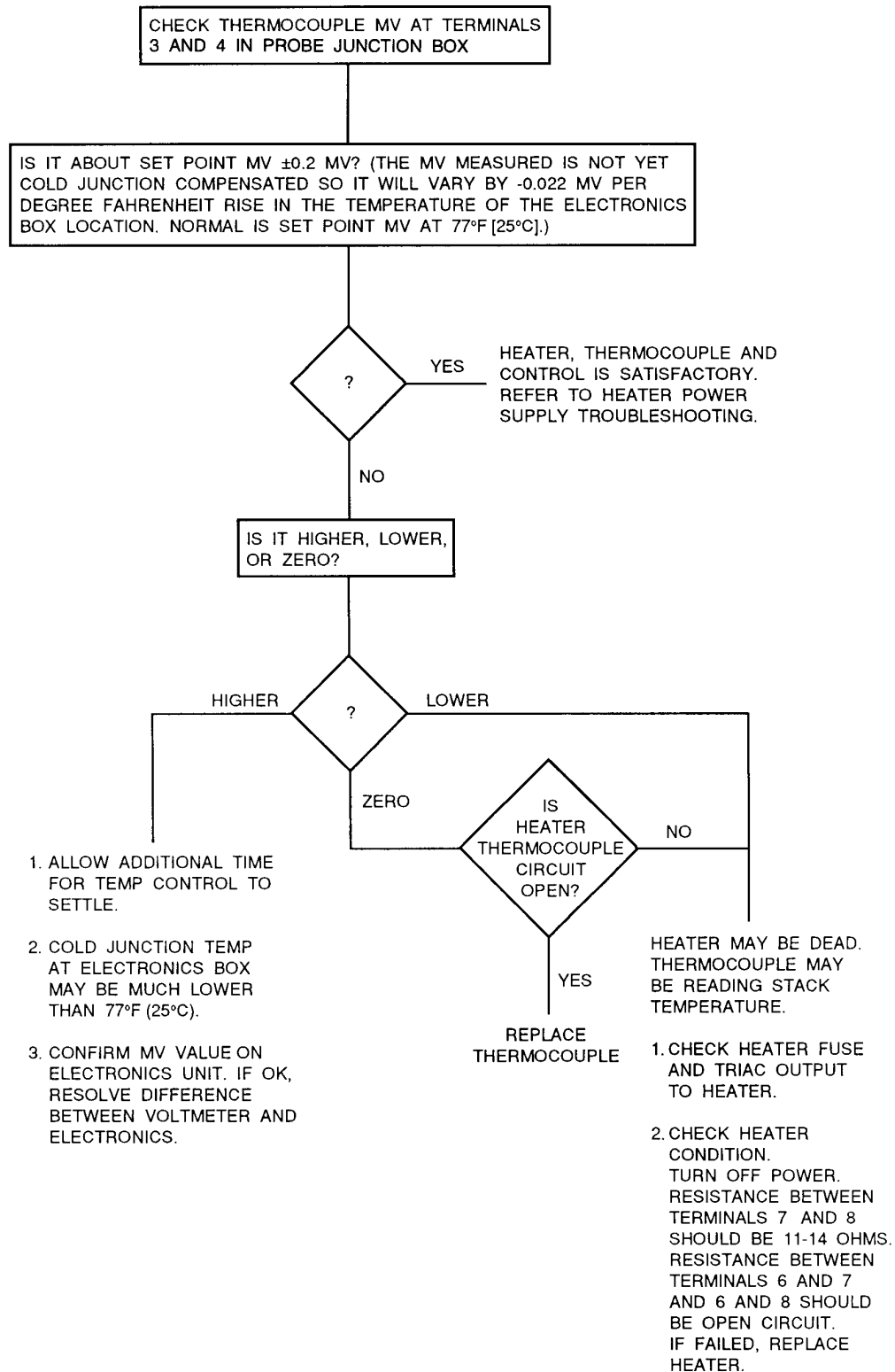

Figure A-17. Flowchart of Probe Related Problems, #2

SERVICE AND NORMAL MAINTENANCE



NOTE

UPON COMPLETING INSTALLATION, MAKE SURE THAT THE PROBE IS TURNED ON AND OPERATING PRIOR TO FIRING UP THE COMBUSTION PROCESS. DAMAGE CAN RESULT FROM HAVING A COLD PROBE EXPOSED TO THE PROCESS GASES.

During outages, and if possible, leave all probes running to prevent condensation and premature aging from thermal cycling.

CAUTION

If the ducts will be washed down during outage, MAKE SURE to power down the probes and remove them from the wash area.

A-9 OVERVIEW

This section describes routine maintenance of the oxygen analyzer probe. Spare parts referred to are available from Rosemount. Probe disassembly kit 3535B42G01 contains the required spanner and hex wrenches. Refer to the following section of this appendix for part numbers and ordering information.

precise surface finishes. Do not remove items from packaging until they are ready to be used. Spanner wrenches and hex wrenches needed for this procedure are part of an available special tools kit, Table A-3.

WARNING

Install all protective equipment covers and safety ground leads after equipment repair or service. Failure to install covers and ground leads could result in serious injury or death.

WARNING

Wear heat resistant gloves and clothing to remove probe from stack. Normal operating temperatures of diffusor and vee deflector are approximately 600° to 800°F (316° to 427°C). They could cause severe burns.

Disconnect and lock out power before working on any electrical components. There is voltage up to 115 Vac.

A-10 PROBE RECALIBRATION

The oxygen analyzer system should be calibrated when commissioned. Under normal circumstances the probe will not require frequent calibration. When calibration is required, follow the procedure described in the Instruction Bulletin applicable to your electronics package.

CAUTION

Do not remove cell unless it is certain that replacement is needed. Removal may damage cell and platinum pad. Go through complete troubleshooting procedure to make sure cell needs replacement before removing it.

A-11 CELL REPLACEMENT

This paragraph covers oxygen sensing cell replacement. Do not attempt to replace the cell until all other possibilities for poor performance have been considered. If cell replacement is needed, order cell replacement kit, Table A-3.

The cell replacement kit contains a cell and flange assembly, corrugated seal, setscrews, socket head cap screws, and anti-seize compound. Items are carefully packaged to preserve

- a. Disconnect and lock out power to electronics. Shut off and disconnect reference air and calibration gas supplies from probe junction box, Figure A-18. Wearing heat resistant gloves and clothing, remove probe assembly from stack carefully and allow to cool to room temperature. Do not attempt to work on unit until it has cooled to a comfortable working temperature.

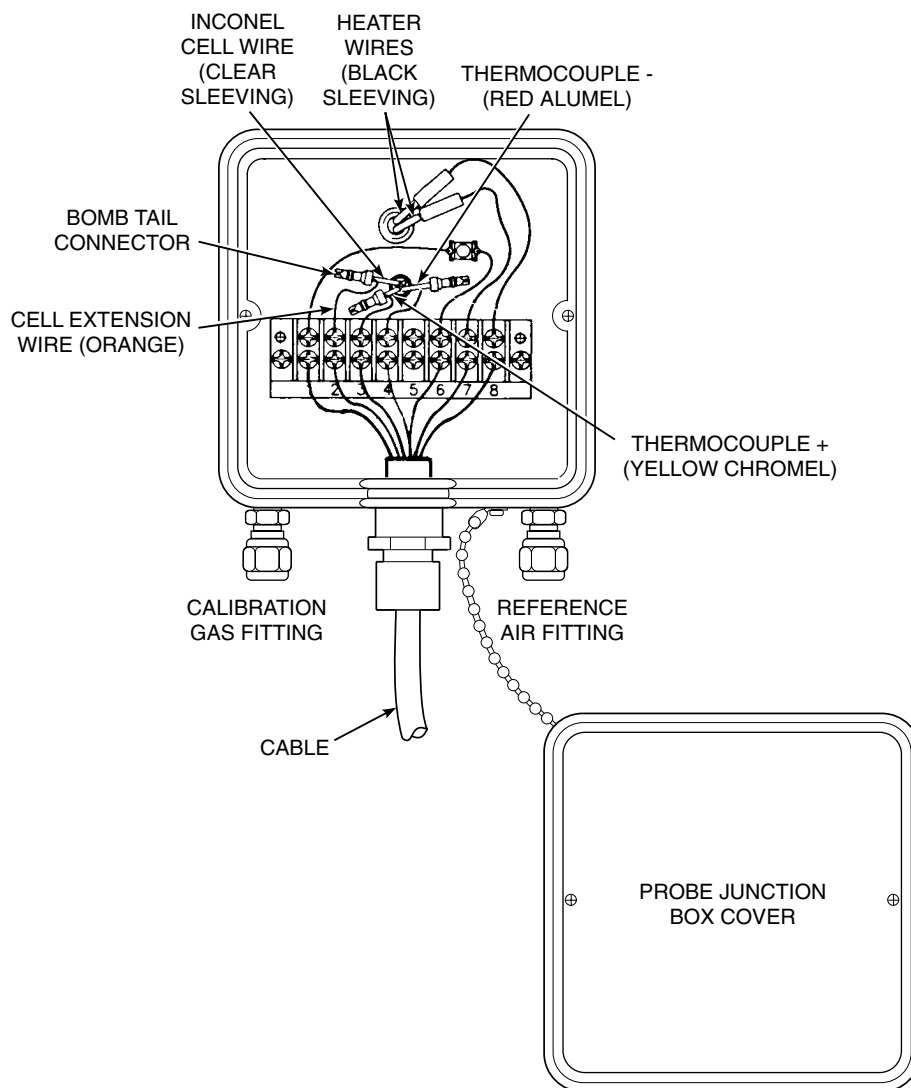

27270019

Figure A-18. Cell Wiring Connection

- b. If the probe uses the standard diffusion element, use a spanner wrench to remove the diffusion element.
- c. If equipped with the optional ceramic diffusor assembly, remove and discard setscrews, Figure A-19, and remove vee deflector. Use spanner wrenches from probe disassembly kit, Table A-3, to turn hub free from retainer. Inspect diffusion element. If damaged, replace element.
- d. Loosen four socket head cap screws from the cell and flange assembly and remove the assembly and the corrugated seal. The cell flange has a notch which may be used

to gently pry the flange away from the probe. Note that the contact pad inside the probe will sometimes fuse to the oxygen sensing cell. If the cell is fused to the contact pad, push the cell assembly back into the probe (against spring pressure), and quickly twist the cell assembly. The cell and contact pad should separate. **If the contact pad stays fused** to the cell, a new contact/thermocouple assembly must be installed. Disconnect the cell and the thermocouple wires at the probe junction box, and withdraw the cell with the wires still attached (see paragraph A-13).

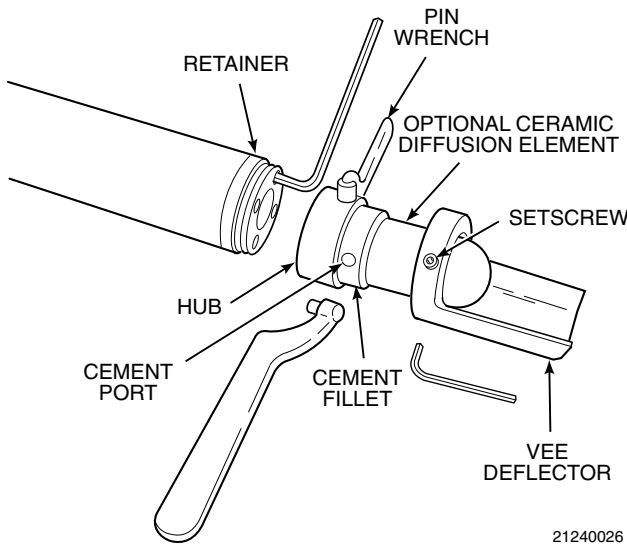

Figure A-19. Removal of Optional Diffusor and Vee Deflector

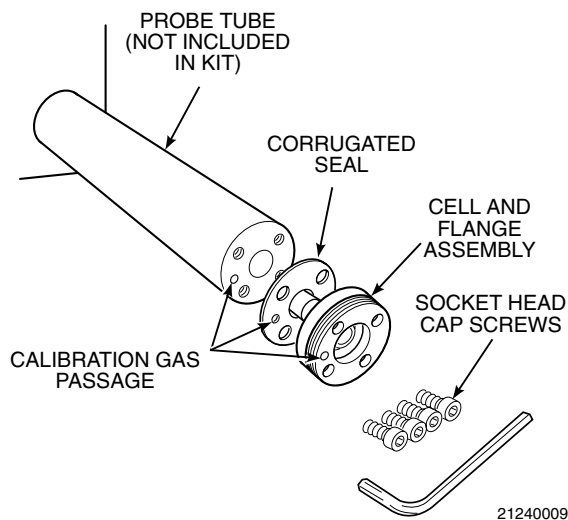

Figure A-20. Cell Replacement Kit

- e. If contact assembly is damaged, replace contact and thermocouple according to paragraph A-13, Replacement of Contact and Thermocouple Assembly.
- f. Remove and discard corrugated seal. Clean mating faces of probe tube and retainer. Remove burrs and raised surfaces with block of wood and crocus cloth. Clean threads on retainer and hub.

- g. Rub a small amount of anti-seize on both sides of new corrugated seal.
- h. Assemble cell and flange assembly, corrugated seal, and probe tube. Make sure the calibration tube lines up with the calibration gas passage in each component. Apply a small amount of anti-seize compound to screw threads and use screws to secure assembly. Torque to 55 in-lbs (4 N·m).
- i. Apply anti-seize compound to threads of cell assembly, hub, and setscrews. Reinstall hub on cell assembly. Using pin spanner wrenches, torque to 10 ft-lbs (14 N·m). If applicable, reinstall vee deflector, orienting apex toward gas flow. Secure with setscrews and anti-seize compound. Torque to 25 in-lbs (2.8 N·m).
- j. On systems equipped with an abrasive shield, install dust seal gaskets, with joints 180° apart.
- k. Reinstall probe and gasket on stack flange. If there is an abrasive shield in the stack, make sure dust seal gaskets are in place as they enter 15° reducing cone.
- l. Turn power on to electronics and monitor thermocouple output. It should stabilize at 29.3 ± 0.2 mV. Set reference air flow at 2 scfh (56.6 L/hr). After probe stabilizes, calibrate probe per Instruction Bulletin applicable to your electronics package. If new components have been installed, repeat calibration after 24 hours of operation.

A-12 OPTIONAL CERAMIC DIFFUSION ELEMENT REPLACEMENT

a. General

The diffusion element protects the cell from particles in process gases. It does not normally need to be replaced because the vee deflector protects it from particulate erosion. In severe environments the filter may be broken or subject to excessive erosion. Examine the diffusion element whenever removing the probe for any purpose. Replace if damaged.

World Class 3000

Damage to the diffusion element may become apparent during calibration. Compare probe response with previous response. A broken diffusion element will cause a slower response to calibration gas.

Hex wrenches needed to remove setscrews and socket head screws in the following procedure are available as part of a special tool kit, Table A-3.

WARNING

Wear heat resistant gloves and clothing to remove probe from stack. Normal operating temperatures of diffusor and vee deflector are approximately 600° to 800°F (300° to 425°C). They can cause severe burns.

Disconnect and lock out power before working on any electrical component. There is voltage up to 115 Vac.

CAUTION

It is not necessary to remove the cell unless it is certain that replacement is necessary. Cell cannot be removed for inspection without damaging it. Refer to paragraph A-11, Cell Replacement.

b. Replacement Procedure

1. Shut off power to electronics. Disconnect cable conductors and remove cable, Figure A-18. Shut off and disconnect reference air and calibration gas supplies from probe junction box. Wearing heat resistant gloves and clothing, carefully remove probe assembly from stack and allow to cool to room temperature. Do not attempt to work on unit until it has cooled to a comfortable working temperature.
2. Loosen setscrews, Figure A-19, using hex wrench from special tools kit, Table A-3, and remove vee deflector. Inspect setscrews. If damaged, replace with M-6 x 6 stainless setscrews coated with anti-seize compound.
3. On systems equipped with abrasive shield, remove dual dust seal gaskets.
4. Use spanner wrenches from special tools kit, Table A-3, to turn hub free from retainer.
5. Put hub in vise. Break out old diffusion element with chisel along cement line and 3/8 inch (9.5 mm) pin punch through cement port.
6. Break out remaining diffusion element by tapping lightly around hub with hammer. Clean grooves with pointed tool if necessary.
7. Replace diffusion element, using replacement kit listed in Table A-3. This consists of a diffusion element, cement, setscrews, anti-seize compound and instructions.
8. Test fit replacement element to be sure seat is clean.
9. Thoroughly mix cement and insert tip of squeeze bottle into cement port. Tilt bottle and squeeze while simultaneously turning diffusion element into seat. Do not get any cement on upper part of diffusion element. Ensure complete penetration of cement around three grooves in hub. Cement should extrude from opposite hole. Wipe excess material back into holes and wipe top fillet of cement to form a uniform fillet. (A Q-Tip is useful for this.) Clean any excess cement from hub with water.
10. Allow filter to dry at room temperature overnight or 1 to 2 hours at 200°F (93°C).

CAUTION

Do not get cement on diffusion element except where it touches the hub. Any cement on ceramic element blocks airflow through element. Wiping wet cement off of ceramic only forces cement into pores.

11. Wipe a heavy layer of anti-seize compound onto the threads and mating surfaces of the diffusion hub and retainer.
12. Assemble retainer and diffusion hub with two pin spanner wrenches. Torque to 10 ft-lbs (14 N·m).
13. On systems equipped with abrasive shield, install dust seal gaskets with joints 180° apart.
14. Reinstall vee deflector, orienting apex toward gas flow. Apply anti-seize compound to setscrews and tighten with hex wrench.
15. Reinstall probe on stack flange.
16. Turn power on to electronics and monitor thermocouple output. It should stabilize at 29.3 ± 0.2 mV. Calibrate probe per Instruction Bulletin applicable to your electronics package.

Squeezing tabs on hose clamps, remove hoses from probe junction box, Figure A-21. Remove four screws in corners of probe junction box. Pull probe junction box and inner probe assembly free from probe tube. Set on bench and allow to cool to room temperature.

- b. Disconnect cell extension wire (orange), thermocouple wire (red alumel), and thermocouple wire (yellow chromel) by cutting bomb tail connections from the terminal strip, Figure A-18.
- c. Remove two screws, Figure A-21, lock-washers, and flat washers that connect probe junction box to inner probe assembly. Pull heater, V-strut and backplate assembly away from probe junction box. Inspect all O-rings and insulating gasket; replace if worn or damaged.

A-13 REPLACEMENT OF CONTACT AND THERMOCOUPLE ASSEMBLY

WARNING

Use heat resistant gloves and clothing when removing probe junction box and inner probe assembly. Do not attempt to work on these components until they have cooled to room temperature. Probe components can be as hot as 800°F (427°C). This can cause severe burns.

Disconnect and lock out power before working on any electrical components. There is voltage up to 115 Vac.

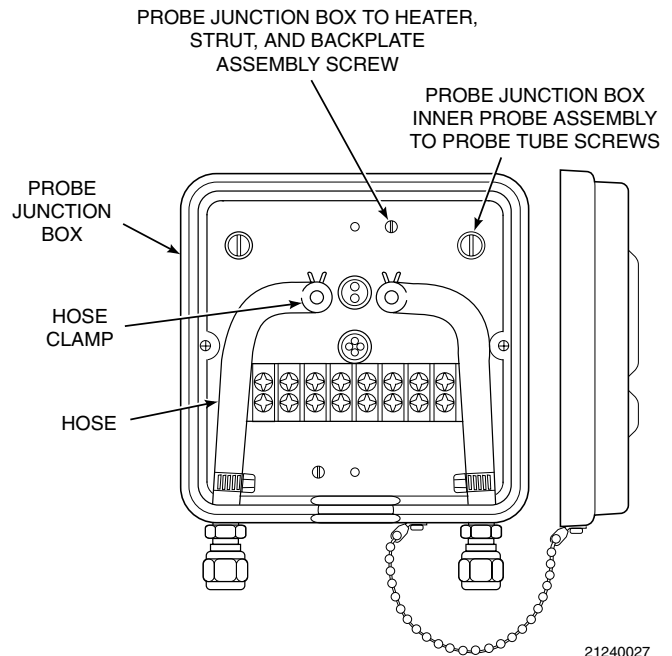

Figure A-21. Probe Junction Box Mechanical Connections

- a. Disconnect and lock out power to electronics. Using heat resistant gloves and clothing, remove probe junction box cover.

- d. Use a pencil to mark locations of spring clip on ceramic rod, Figure A-22.
- e. Pry or squeeze tabs on spring clips, and pull contact and thermocouple assembly out of probe assembly. Retain spring clips and spring; replace if damaged.

CAUTION

Be very careful when handling contact and thermocouple assembly. The ceramic rod in this assembly is fragile.

- f. While very carefully handling new contact and thermocouple assembly, lay old assembly next to new one. Transfer pencil marks to new rod.

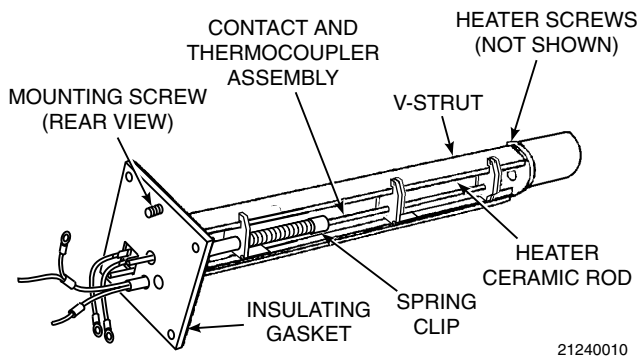

Figure A-22. Inner Probe Replacement (Heater, V-Strut, and Backplate Assembly)

- g. Note wire lengths of old assembly as an aid for trimming new lengths in step (j). Trimming of wires will not always be necessary. Throw away old contact and thermocouple assembly.
- h. Carefully guide new contact and thermocouple assembly through V-strut assembly leaf spring (4, Figure A-23), spring (9), spring clip (10) (held open by squeezing tabs), and tube supports (11, 13) until spring clip reaches pencil mark.
- i. Reinstall insulating gasket on backplate, replace two screws, O-rings, lockwashers and flat washers connecting probe junction box to inner probe assembly.

CAUTION

Do not trim new wiring shorter than existing (old) wiring. Excessive wire trim will prevent connections from being properly made and will require a new replacement kit.

- j. Trim wires, if necessary, as noted in step (g).
- k. Connect color coded wires to proper terminals as shown in Figure A-18. Rosemount recommends connecting the thermocouple wires directly to the terminal strip. This is because the junction of different metals at the wires and lugs and at the lugs and the

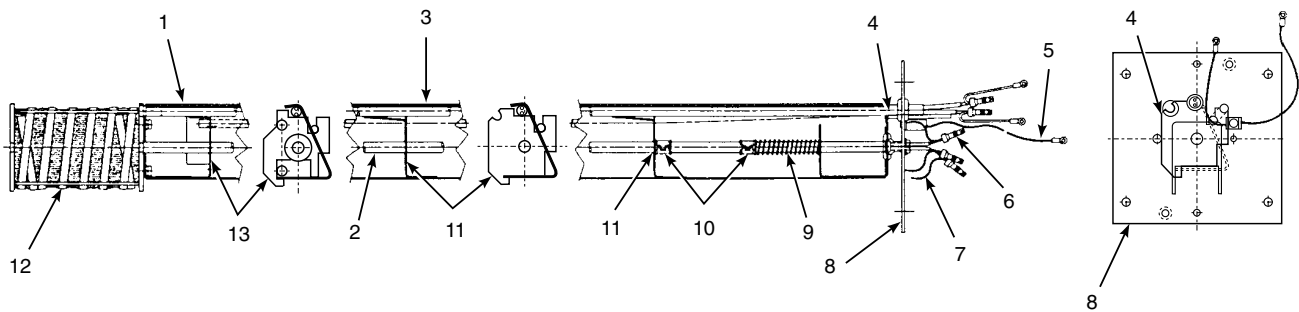

- | | | |
|--------------------------------------|-------------------|--------------------------|
| 1. Heater Ceramic Rod | 5. Ring Lug | 9. Spring |
| 2. Contact and Thermocouple Assembly | 6. Butt Connector | 10. Spring Clip Assembly |
| 3. Strut | 7. Extension | 11. Common Tube Support |
| 4. Leaf Spring | 8. Backplate | 12. Heater |
| | | 13. Short Tube Support |

Figure A-23. Heater, Strut, and Backplate Assembly (Inner Probe Assembly)

terminal strip could act as additional thermocouple junctions. This could produce a voltage that would affect the thermocouple output signal.

Do not bend wires closer than 1/4 inch (6.4 mm) from end of ceramic rod. Dress wires so they do not touch sides of probe junction box.

- I. Slide assembled probe junction box and inner probe assembly into probe tube. To align calibration gas tube with corresponding hole in backplate (A, B, Figure A-1), insert scribe through hole in backplate and into calibration gas tube. Secure with screws. Reinstall hoses and probe junction box cover.
- m. Power up system. Monitor thermocouple output. It should stabilize at set point mV ± 0.2 mV. Recalibrate probe per Instruction Bulletin applicable to your electronics package.

A-14 REPLACEMENT OF HEATER, V-STRUT AND BACKPLATE ASSEMBLY (INNER PROBE ASSEMBLY; INCLUDES CONTACT AND THERMOCOUPLE ASSEMBLY)

WARNING

Use heat resistant gloves and clothing when removing probe junction box and inner probe assembly. Do not attempt to work on these components until they have cooled to room temperature. Probe components can be as hot as 800° (427°C). This can cause severe burns.

Disconnect and lock out power before working on any electrical components. There is voltage up to 115 Vac.

NOTE

This replacement may be done without removing the probe from the duct.

- a. Disconnect and lock out power to electronics. Using heat resistant gloves and clothing, remove probe cover. Squeezing tabs on hose clamps and remove hoses from probe junction box, Figure A-21. Remove four screws and lockwashers (7, 10, Figure A-24) that hold probe junction box and inner probe assembly to probe tube. Pull probe junction box and inner probe assembly free from probe tube. Set on bench and allow to cool to room temperature.
- b. Disconnect cell extension wire (orange), thermocouple wire (red alumel), and thermocouple wire (yellow chromel) by cutting bomb tail connections from the terminal strip, Figure A-18.
- c. Remove two screws, lockwashers, and flat washers that connect probe junction box to inner probe assembly. Remove and discard inner probe assembly (heater, V-strut, and backplate assembly). Replace with new inner probe assembly. Reinstall screws, lockwashers and flat washers.
- d. Connect color coded wires to proper terminals as shown in Figure A-18. Rosemount recommends connecting the thermocouple wires directly to the terminal strip. This is because the junction of different metals at the wires and lugs and at the lugs and the terminal strip could act as additional thermocouple junctions. This could produce a voltage that would affect the thermocouple output signal.

Do not bend wires closer than 1/4 inch (6.4 mm) from end of ceramic rod. Dress wires so they do not touch sides of probe junction box.

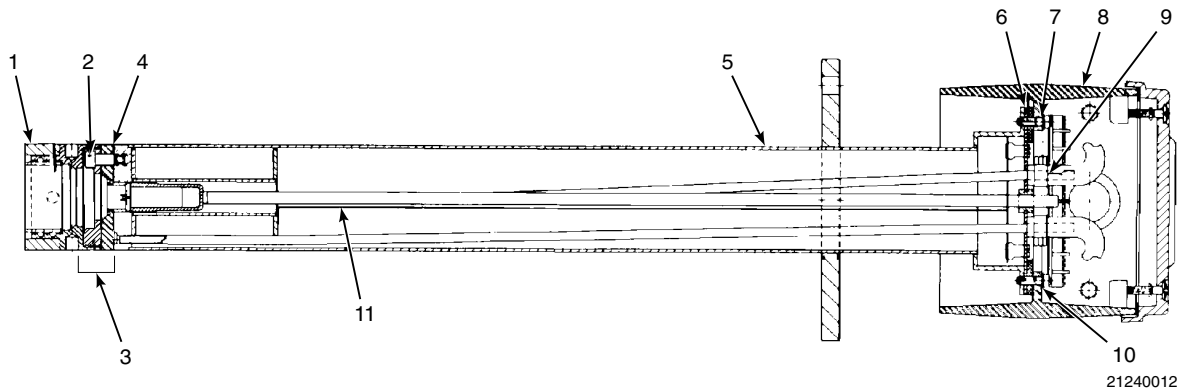

- | | |
|--|--|
| 1. Snubber Diffusion Element | 6. Gasket [4.0 in. (102 mm) x 4.0 in. x 0.12 in. (3 mm)] |
| 2. Socket Hd Cap Screw [0.25 in.-28 x 0.063 (16 mm)] | 7. Fillister Hd Screw [8-32 x 0.5 in. (12.7 mm)] |
| 3. Cell and Flange Assembly | 8. Cover Head Assembly |
| 4. Corrugated Seal | 9. Hose Clamp |
| 5. Probe Tube Assembly | 10. Lockwasher (#8 Split) |
| | 11. Heater Strut Assembly |

Figure A-24. Oxygen Analyzer (Probe), Cross-Sectional View

- e. Slide assembled probe junction box and inner probe assembly into probe tube. To align calibration gas tube with corresponding hole in backplate (A, B, Figure A-1), insert aligning tool (included in probe disassembly kit, P/N 3535B42G01) through hole in backplate and into calibration gas tube, while sliding the heater strut into the probe tube. Secure with screws. Reinstall hoses and probe junction box cover.
- f. Power up system. Monitor thermocouple output. It should stabilize at set point ± 0.2 mV. Recalibrate probe per Instruction Bulletin applicable to your electronics package.

a. Installation Procedure

WARNING

Use heat resistant gloves and clothing when removing probe junction box and inner probe assembly. Do not attempt to work on these components until they have cooled to room temperature. Probe components can be as hot as 800°F (427°C). This can cause severe burns.

Disconnect and lock out power before working on any electrical components. There is voltage up to 115 Vac.

A-15 CALIBRATION GAS AND REFERENCE AIR LINES FOR HIGH TEMPERATURE - CORROSIVE ENVIRONMENT OPERATION

A high temperature, corrosive environment kit is available when the probe is exposed to these types of operating conditions. The kit includes stainless steel tubing and teflon fittings for inside the probe junction box. The kit part number is 4843B93G01.

- 1. Disconnect and lock out power to digital electronics. Using heat resistant gloves and clothing, remove probe cover. Squeezing tabs on hose clamps, remove hoses from probe junction box (Figure A-21).

CAUTION

Do not use sealant when installing the stainless steel tubes. Gas samples may become contaminated.

2. First install the stainless steel tubing on the fitting at the bottom of the probe junction box. Install the other end of the stainless steel tube onto the tube going to the probe (Figure A-25).

NOTE

If abrasive conditions of high ash content and high velocity exist, an abrasive shield is recommended. To balance out the wear on the shield, rotate the shield 90° every time the probe is powered down for service.

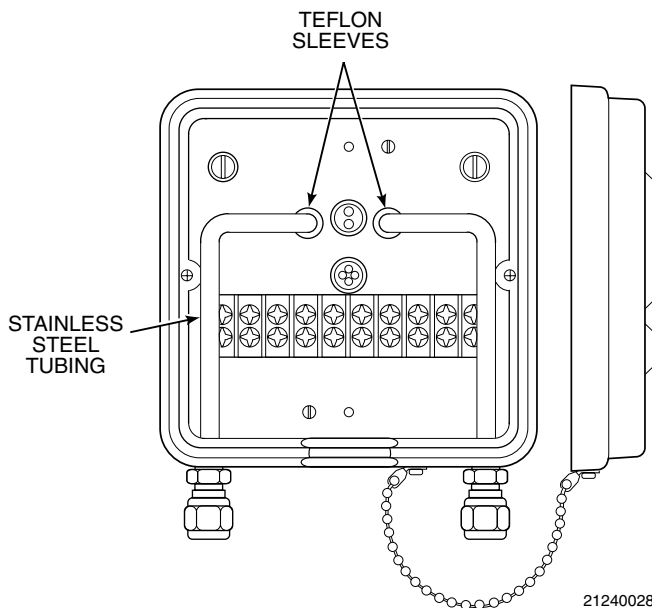

Figure A-25. High Temperature - Corrosive Environment Kit

REPLACEMENT PARTS

Table A-3. Replacement Parts for Probe

Figure and Index No.	Part Number	Description
Figure A-22	3D39441G06 ¹	Heater, V-Strut, and Backplate Assembly, 18 in. (45.6 cm)
Figure A-22	3D39441G07 ¹	Heater, V-Strut, and Backplate Assembly, 3 ft (0.9 m)
Figure A-22	3D39441G08 ¹	Heater, V-Strut, and Backplate Assembly, 6 ft (1.8 m)
Figure A-22	3D39441G09 ¹	Heater, V-Strut, and Backplate Assembly, 9 ft (2.7 m)
Figure A-22	3D39441G10 ¹	Heater, V-Strut, and Backplate Assembly, 12 ft (3.6 m)
Figure A-23, 2	3534B56G04 ²	Contact and Thermocouple Assembly, 18 in. (45.6 cm)
Figure A-23, 2	3534B56G05 ²	Contact and Thermocouple Assembly, 3 ft (0.9 m)
Figure A-23, 2	3534B56G06 ²	Contact and Thermocouple Assembly, 6 ft (1.8 m)
Figure A-23, 2	3534B56G07 ²	Contact and Thermocouple Assembly, 9 ft (2.7 m)
Figure A-23, 2	3534B56G08 ²	Contact and Thermocouple Assembly, 12 ft (3.6 m)
Figure A-7	3D39003G01 ³	Abrasive Shield Assembly, 3 ft (0.9 m)
Figure A-7	3D39003G02 ³	Abrasive Shield Assembly, 6 ft (1.8 m)
Figure A-7	3D39003G03 ³	Abrasive Shield Assembly, 9 ft (2.7 m)
Figure A-7	3D39003G08 ³	Abrasive Shield Assembly, 12 ft (3.6 m)
Figure A-20	4847B61G01	Cell Replacement Kit, ANSI, No Lead Wire
Figure A-20	4847B61G02	Cell Replacement Kit, ANSI 18 in. (45.6 cm)
Figure A-20	4847B61G03	Cell Replacement Kit, ANSI 3 ft (0.9 m)
Figure A-20	4847B61G04	Cell Replacement Kit, ANSI 6 ft (1.8 m)
Figure A-20	4847B61G05	Cell Replacement Kit, ANSI 9 ft (2.7 m)
Figure A-20	4847B61G06	Cell Replacement Kit, ANSI 12 ft (3.6 m)
Figure A-20	4847B61G07	Cell Replacement Kit, JIS, No Lead Wire
Figure A-20	4847B61G08	Cell Replacement Kit, JIS 18 in. (45.6 cm)
Figure A-20	4847B61G09	Cell Replacement Kit, JIS 3 ft (0.9 m)
Figure A-20	4847B61G10	Cell Replacement Kit, JIS 6 ft (1.8 m)
Figure A-20	4847B61G11	Cell Replacement Kit, JIS 9 ft (2.7 m)
Figure A-20	4847B61G12	Cell Replacement Kit, JIS 12 ft (3.6 m)
Figure A-20	4847B61G13	Cell Replacement Kit, DIN, No Lead Wire
Figure A-20	4847B61G14	Cell Replacement Kit, DIN 18 in. (45.6 cm)
Figure A-20	4847B61G15	Cell Replacement Kit, DIN 3 ft (0.9 m)
Figure A-20	4847B61G16	Cell Replacement Kit, DIN 6 ft (1.8 m)
Figure A-20	4847B61G17	Cell Replacement Kit, DIN 9 ft (2.7 m)
Figure A-20	4847B61G18	Cell Replacement Kit, DIN 12 ft (3.6 m)
Figure A-20	3535B42G01	Probe Disassembly Kit
Figure A-10	3534B18G01	Diffuser Assembly
Figure A-8	3535B60G01	Diffuser Dust Seal Hub Assembly (For use with Abrasive Shield)

Table A-3. Replacement Parts for Probe (Continued)

Figure and Index No.	Part Number	Description
Figure A-9	3535B63G01	Flame Arrestor Diffuser Dust Seal
Figure A-11	3535B62G01	Flame Arrestor Diffuser
Figure A-4	3534B48G01	Vee Deflector Assembly (For use with standard or dust seal type ceramic diffusers)
Figure A-19	6292A74G02 1537B70G03	Diffusion Element Replacement Kit Horizontal and Vertical Brace Clamp Assembly, 9 and 12 foot (2.7 and 3.6 m) probe
Figure A-25	4843B93G01	High Temperature - Corrosive Environment Kit
Figure A-1, 2	4843B37G01	Snubber Diffusion Assembly
Figure A-12	4843B38G02	Dust Seal/Snubber Diffusion Assembly
Figure A-14	4851B89G04	Cup Type Diffusion Assembly, 5 microns
	4851B89G05	Cup Type Diffusion Assembly, 40 microns
Figure A-13	4851B90G04	Cup Type Diffusion Assembly/Dust Seal, 5 microns
	4851B90G05	Cup Type Diffusion Assembly/Dust Seal, 40 microns

¹Heater, V-strut, and backplate assembly includes contact and thermocouple assembly.

²Contact and thermocouple assembly includes platinum pad and inconel wire.

³Abrasive shield assembly includes accessories necessary for its use and a mounting plate and gasket.

APPENDIX B, REV. 2.2 HPS 3000 HEATER POWER SUPPLY

DESCRIPTION

WARNING

Read the “Safety instructions for the wiring and installation of this apparatus” at the front of this Instruction Bulletin. Failure to follow the safety instructions could result in serious injury or death.

B-1 DESCRIPTION

The Rosemount HPS 3000 Heater Power Supply Field Module acts as an interface between probe and electronics, and supplies power to the probe heater. The unit allows the use of probes with a number of different electronics packages.

The HPS is available in a NEMA 4X (IP56) non-hazardous enclosure or an optional Class 1, Division 1, Group B (IP56) explosion-proof enclosure, Figure B-1.

The heater power supply, Figure B-2, consists of a mother board, daughter board, and a transformer for supplying correct voltage to the probe heater. The mother and daughter boards contain terminal strips for connecting probe, electronics, and power supply.

The HPS is jumper configurable for 120, 220, or 240 Vac. For 100 Vac usage, the HPS is factory-supplied with a special transformer. The 100 Vac transformer can also be easily field installed. Refer to paragraph B-7, Transformer Replacement for installation procedure; refer to Table B-2, for transformer part numbers.

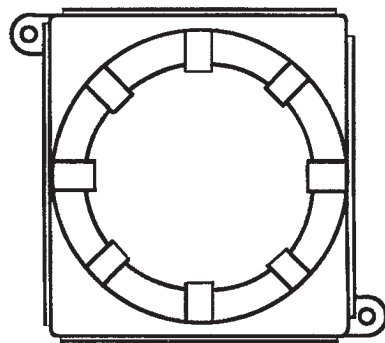

OPTIONAL CLASS 1,
DIVISION 1, GROUP B (IP56)
EXPLOSION-PROOF ENCLOSURE

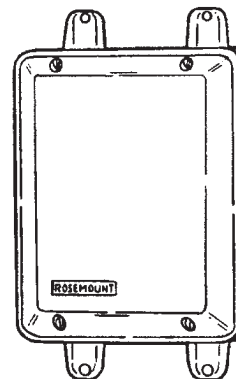

NEMA 4X (IP56)
NON-HAZARDOUS
ENCLOSURE

35730001

Figure B-1. HPS 3000 Heater Power Supply Field Module

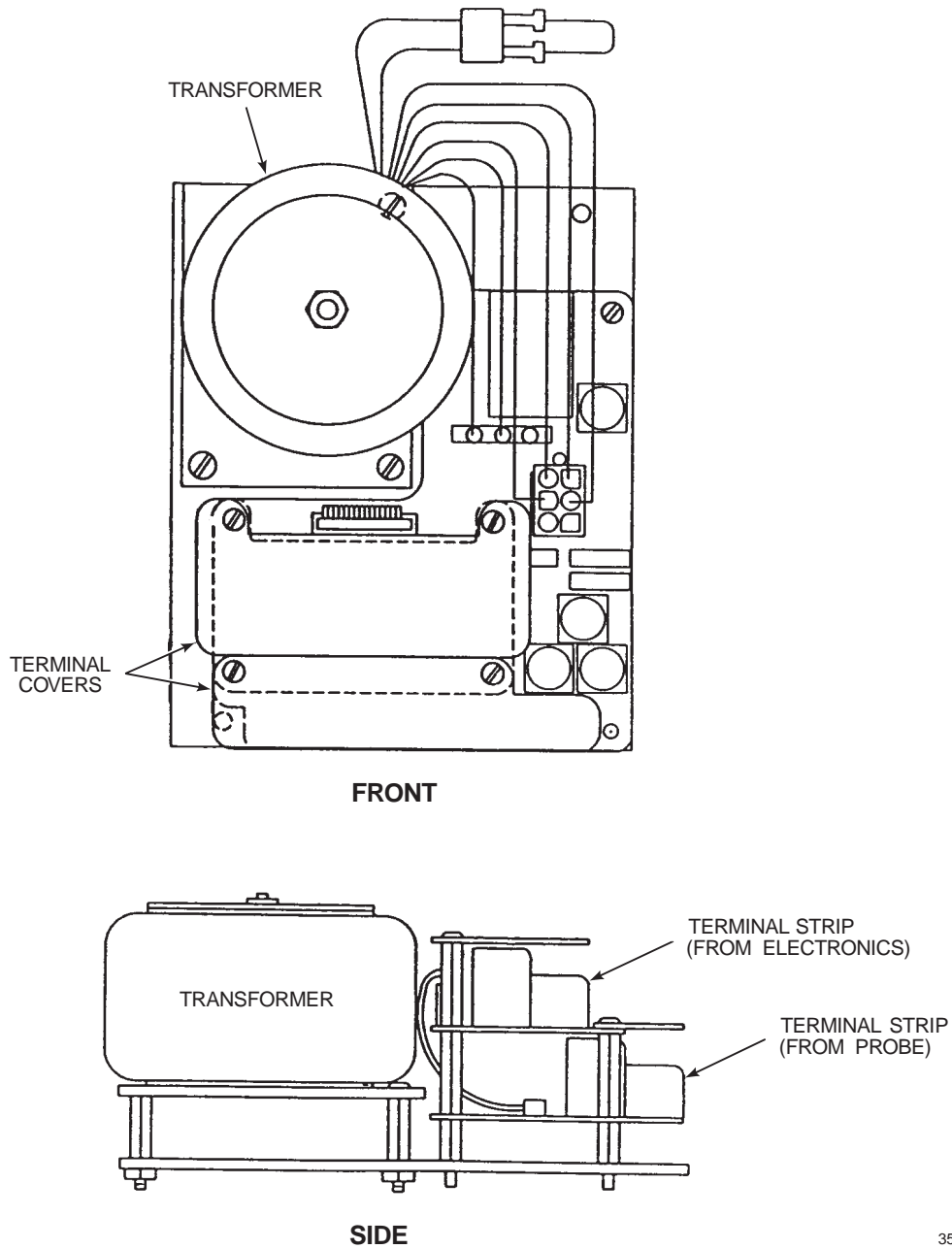

Figure B-2. Heater Power Supply, Interior

Table B-1. Specifications for Heater Power Supply

Environmental Classification	NEMA 4X (IP56) Optional - Class 1, Division 1, Group B (IP56)
Electrical Classification	Category II
Humidity Range	95% Relative Humidity
Ambient Temperature Range	-20° to 140°F (-30° to 60°C)
Vibration	5 m/sec ² , 10 to 500 xyz plane
Cabling Distance Between HPS 3000 and Probe	Maximum 150 feet (45 m)
Cabling Distance Between HPS 3000 and CRE 3000	Maximum 1200 feet (364 m)
Cabling Distance Between HPS 3000 and IFT 3000	Maximum 1200 feet (364 m)
Approximate Shipping Weight	12 pounds (5.4 kg)

B-2 THEORY OF OPERATION

The HPS 3000 Heater Power Supply may perform slightly different functions, depending upon which electronics package it is used with. Figure B-3 shows a functional block diagram of the unit. The HPS contains a transformer for converting line voltage to 44 volts needed to power the probe heater. The relay, Figure B-3, can be used to remotely turn the probe on or off manually. A triac module is used to turn the heater on or off, depending on probe temperature.

When used with the CRE 3000 Control Room Electronics or IFT 3000 Intelligent Field Transmitter, the HPS uses a cold junction temperature compensation feature. This allows for the

use of a less expensive cable between the HPS and CRE or HPS and IFT. The HPS and electronics package can be located up to 1200 feet (364 m) apart.

The standard cable, between probe and HPS, is thermocouple compensated. This prevents the additional junctions between thermocouple and cable from producing a voltage which would affect the thermocouple output signal. A temperature sensor in the HPS monitors the temperature at the junction and sends a voltage signal to the CRE and IFT. The CRE and IFT uses this signal to compensate the probe thermocouple reading for the temperature at the junction between the compensated and uncompensated cables.

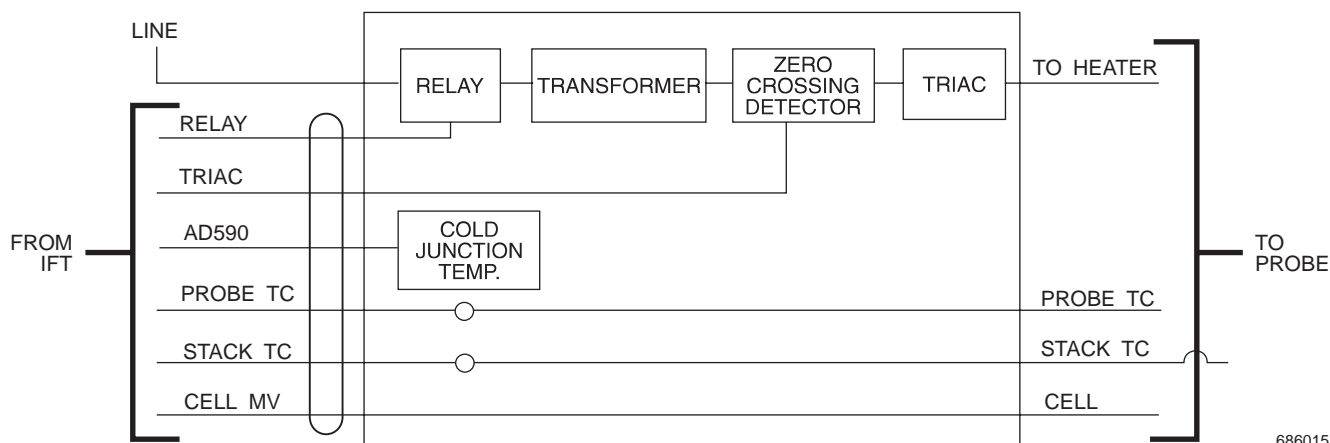

Figure B-3. Heater Power Supply Block Diagram

In operation, when connected to the CRE 3000 Control Room Electronics, line voltage passes through the relay (when on) and is converted into 44 volts by the transformer. If the probe thermocouple indicates that the probe has dropped below operating temperature, a signal from the CRE triggers the triac. The triac then supplies voltage to the probe heater, warming the cell. Conversely, if the probe thermocouple indicates that the probe heater has reached the upper limit of operating temperature, the CRE deactivates the triac, shutting off power to the heater.

NOTE

When using the HPS 3000 with an existing electronics package, such as Models 218, 218A, 225, or TC200, the electronics will not have the input/output capacity to support all of the functions mentioned in this section. Refer to Instruction Bulletin IB-106-300NE.

HPS 3000 TROUBLESHOOTING

B-3 OVERVIEW

The HPS 3000 troubleshooting section describes how to identify and isolate faults which may develop in the HPS 3000 assembly.

WARNING

Install all protective equipment covers and safety ground leads after troubleshooting. Failure to replace covers and ground leads could result in serious injury or death.

B-4 HPS 3000 TROUBLESHOOTING

The HPS 3000 troubleshooting may overlap with the probe in use in the system. Faults in either system may cause an error to be displayed in the electronics package. Figure B-4, Figure B-5, and Figure B-6 provide troubleshooting information.

SYMPTOM

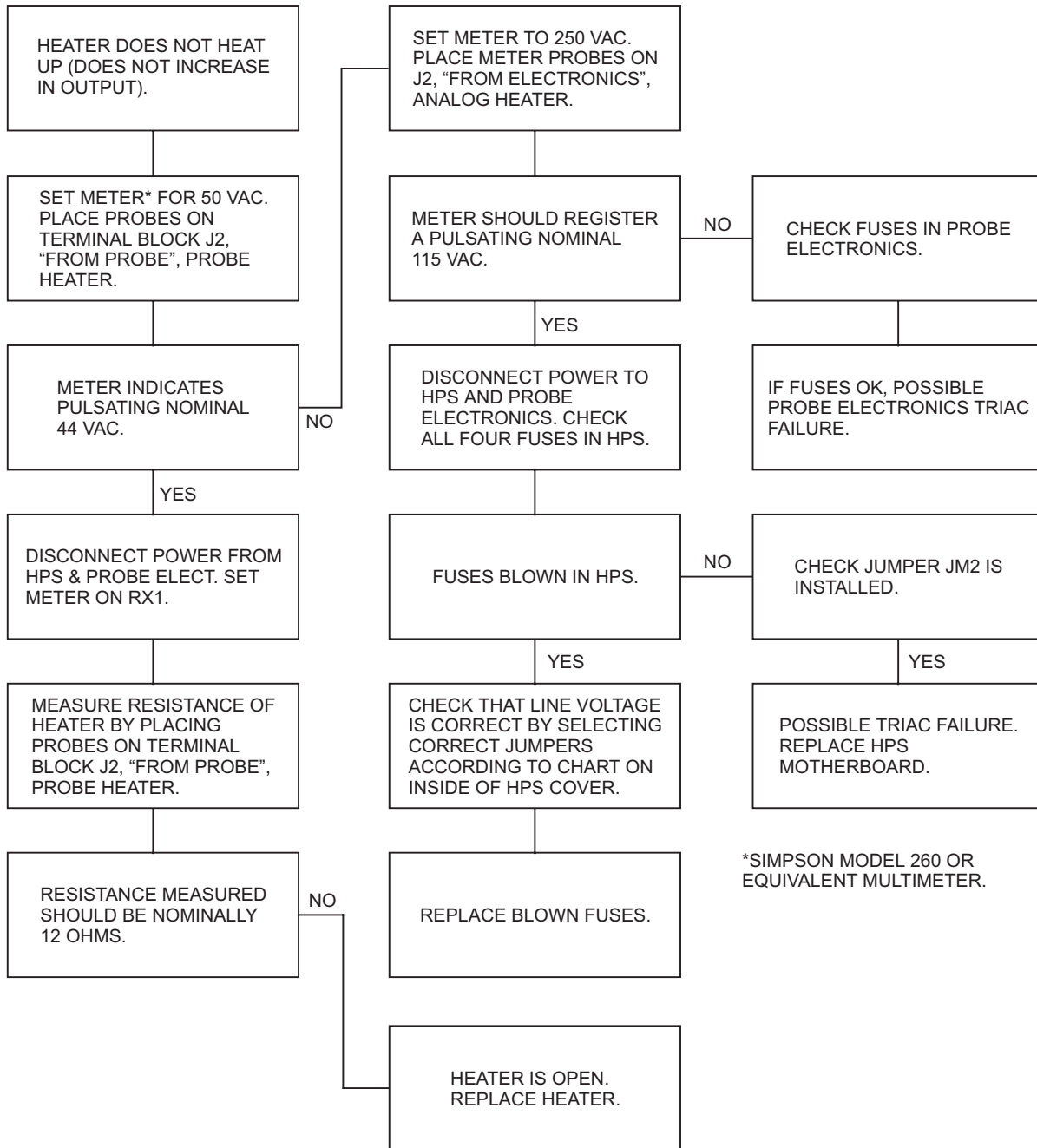

*SIMPSON MODEL 260 OR EQUIVALENT MULTIMETER.

35730004

Figure B-4. HPS Troubleshooting Flowchart, #1

SYMPTOM

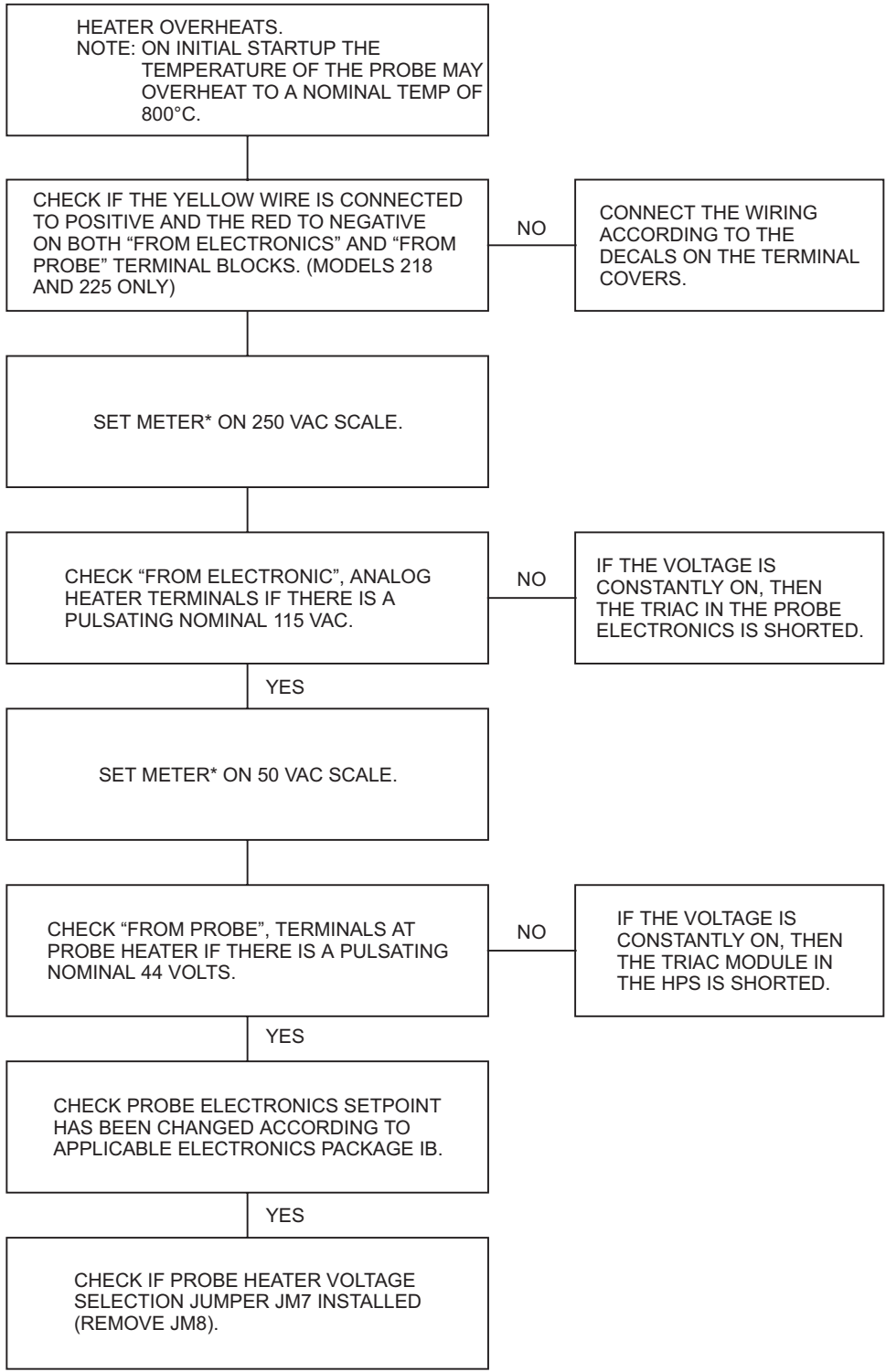

*SIMPSON MODEL 260 OR EQUIVALENT MULTIMETER.

35730003

Figure B-5. HPS Troubleshooting Flowchart, #2

SYMPTOM

PROBE HEATER START TO HEAT UP AND THEN LOOSES TEMPERATURE. (MODEL TC200 ONLY)

CHECK PARAMETER 35 ON TC200. IF THE NUMBER IS NEGATIVE THEN SOMEWHERE THE THERMOCOUPLE WIRES ARE REVERSED.

35730005

Figure B-6. HPS Troubleshooting Flowchart, #3

SERVICE AND NORMAL MAINTENANCE

B-5 OVERVIEW

This section describes service and routine maintenance of the HPS 3000 Heater Power Supply Field Module. Replacement parts referred to are available from Rosemount. Refer to Table B-2 of this manual for part numbers and ordering information.

WARNING

Install all protective equipment covers and safety ground leads after equipment repair or service. Failure to install covers and ground leads could result in serious injury or death.

B-6 FUSE REPLACEMENT

The heater power supply mother board (12, Figure B-7) contains four identical 5 amp fuses. Refer to Table B-1 for replacement fuse specifications. To check or replace a fuse, simply unscrew the top of the fuseholder with a flat head screwdriver and remove fuse. After checking or replacing a fuse, reinstall fuseholder top.

B-7 TRANSFORMER REPLACEMENT

WARNING

Install all protective equipment covers and safety ground leads after equipment repair or service. Failure to install covers and ground leads could result in serious injury or death.

- a. Turn off power to system.
- b. Loosen captive screws retaining HPS cover. Remove cover.
- c. Remove hex nut (25, Figure B-7) from top of transformer assembly. Remove retaining plate (24) and gasket (22).
- d. Disconnect transformer harness plug from mother board.

- e. Remove old transformer. Place new transformer in position and reconnect harness plug as noted in step d.
- f. Place gasket and retaining plate on transformer.
- g. Tighten hex nut only enough to firmly hold transformer in place.
- h. Reinstall HPS cover.

B-8 MOTHER BOARD REPLACEMENT

WARNING

Install all protective equipment covers and safety ground leads after equipment repair or service. Failure to install covers and ground leads could result in serious injury or death.

- a. Turn off power to system.
- b. Loosen captive screws retaining HPS cover. Remove cover.
- c. Remove hex nut (25, Figure B-7) from top of transformer assembly. Remove retaining plate (24) and gasket (22).
- d. Disconnect transformer harness plug from mother board.
- e. Remove screws on either side of terminal strip covers (2). Remove terminal strip covers (4 and 8).
- f. Unplug ribbon cable from the receptacle on the daughter board (7).
- g. Unscrew stand offs on either side of the daughter board. Remove daughter board (7).
- h. Unscrew four stand offs that supported the daughter board.

- i. Making a note of the location and color of each wire, disconnect wires from terminal strip on mother board.
 - j. Remove four screws (9) holding mother board to stand offs (10) on subplate (14).
 - k. Remove mother board (12).
 - l. Position new mother board on stand offs and reinstall screws removed in step j.
 - m. Reconnect wires to terminal strip in positions noted in step i.
 - n. Reinstall four stand offs removed in step h. Position daughter board on stand offs and reinstall stand offs removed in step g.
 - o. Plug ribbon cable back into receptacle on daughter board. Reinstall terminal covers.
 - p. Reinstall transformer, tightening hex nut only enough to hold transformer firmly in position. Reconnect transformer harness plug to mother board.
 - q. Reinstall HPS cover.
- a. Turn off power to system.
 - b. Loosen captive screws retaining HPS cover. Remove cover.
 - c. Remove screws on either side of terminal strip covers (2, Figure B-7). Remove terminal strip covers (4 and 8).
 - d. Making a note of the location and color of each wire, disconnect wires from the terminal strip on the daughter board (7).
 - e. Unplug ribbon cable from receptacle on daughter board.
 - f. Unscrew two stand offs from daughter board. Remove daughter board (7).
 - g. Position new daughter board on four stand offs on mother board. Reinstall the stand offs removed in step f.
 - h. Plug ribbon cable into receptacle on daughter board.
 - i. Reconnect wires to terminal strip in positions noted in step d. Reinstall terminal covers.
 - j. Reinstall HPS cover.

B-9 DAUGHTER BOARD REPLACEMENT

CAUTION

When turning power off at the HPS, also turn off the respective probe at associated electronics. When service on the HPS is completed, restore power at the HPS and the associated electronics.

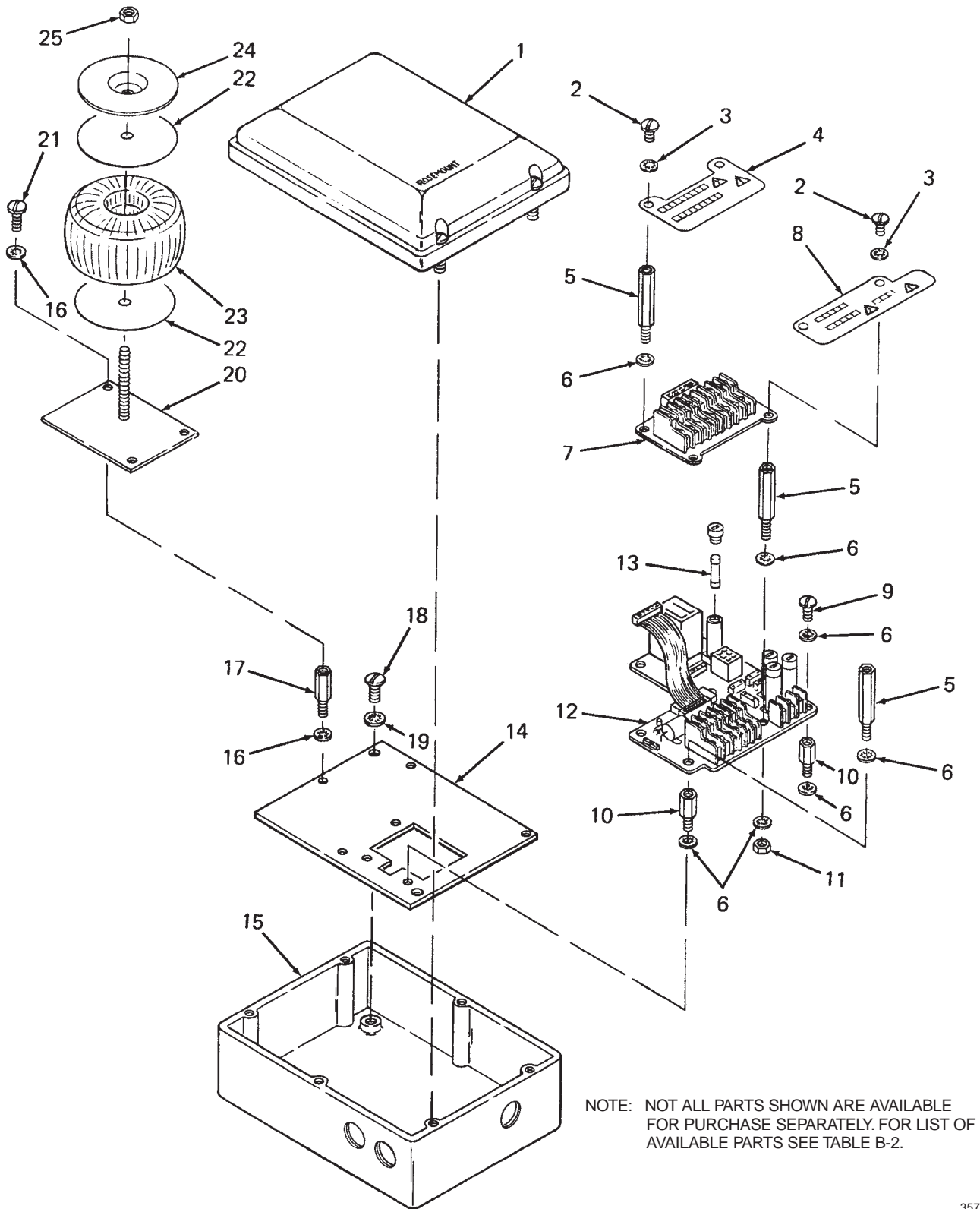

Figure B-7. Heater Power Supply, Exploded View

35730006

LEGEND FOR FIGURE B-7

- | | |
|--------------------|---------------------|
| 1. Enclosure Cover | 14. Subplate |
| 2. Screw | 15. Enclosure Box |
| 3. Lockwasher | 16. Lockwasher |
| 4. Terminal Cover | 17. Stand Off |
| 5. Stand Off | 18. Screw |
| 6. Lockwasher | 19. Lockwasher |
| 7. Daughter Board | 20. Mounting Plate |
| 8. Terminal Cover | 21. Screw |
| 9. Screw | 22. Gasket |
| 10. Stand Off | 23. Transformer |
| 11. Hex Nut | 24. Retaining Plate |
| 12. Mother Board | 25. Hex Nut |
| 13. Fuse | |

REPLACEMENT PARTS

Table B-2. Replacement Parts for Heater Power Supply

FIGURE and INDEX NO.	PART NUMBER	DESCRIPTION
Figure B-1	3D39129G01	Non-Hazardous HPS (120 Vac)
Figure B-1	3D39129G02	Non-Hazardous HPS (100 Vac)
Figure B-1	3D39129G03	Non-Hazardous HPS (220, 240 Vac)
Figure B-1	1U05667G01	Explosion-Proof HPS (120 Vac)
Figure B-1	1U05667G02	Explosion-Proof HPS (100 Vac)
Figure B-1	1U05667G03	Explosion-Proof HPS (220, 240 Vac)
Figure B-7, 13	1L01293H02	Fuse, 5A @ 250 Vac, anti-surge, case size; 5 x 20 mm, type T to IEC127, Schurter
Figure B-7, 12	3D39080G02	Mother Board
Figure B-7, 7	3D39078G01	Daughter Board
Figure B-7, 23	1M02961G01	Transformer (120, 220, 240 Vac)
Figure B-7, 23	1M02961G02	Transformer (100 Vac)

APPENDIX D, REV 2.4

MPS 3000 MULTIPROBE CALIBRATION GAS SEQUENCER

DESCRIPTION

WARNING

Read the "Safety instructions for the wiring and installation of this apparatus" at the front of this Instruction Bulletin. Failure to follow the safety instructions could result in serious injury or death.

D-1 DESCRIPTION

The Rosemount MPS 3000 Multiprobe Calibration Gas Sequencer provides automatic calibration gas sequencing for up to four probes. The MPS routes calibration gas to the selected probe under control of the CRE, IFT, or digital electronics package. The electronics package can be preprogrammed by the user for automatic periodic recalibration, or manually initiated calibration through the keypad on the front of the electronics package. The calibration parameters held in the electronics package can be selected to automatically update after each calibration.

The MPS is housed in a NEMA 4X (IP56) non-hazardous enclosure, Figure D-1.

NOTE

A single multichannel MPS cannot be shared among a number of CRE electronics.

The MPS, Figure D-2, consists of: an air pressure regulator, a terminal board, a flowmeter assembly (one for each probe, up to four per MPS), HI GAS solenoid, LO GAS solenoid, a manifold, and a power supply. Each flowmeter assembly contains a probe solenoid.

An optional Z-purge arrangement is available for hazardous area classification. See Application Data Bulletin AD 106-300B.

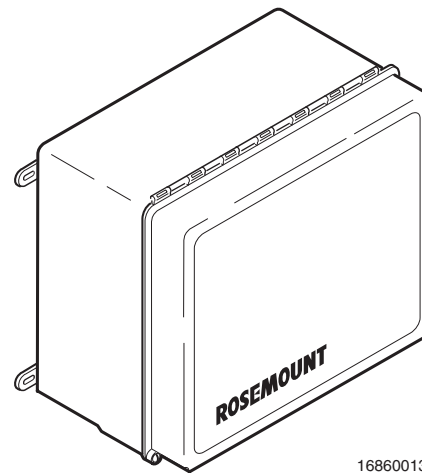

16860013

Figure D-1. MPS 3000 Multiprobe Calibration Gas Sequencer

D-2 THEORY OF OPERATION

A typical automatic calibration setup is shown in Figure D-3. The MPS 3000 Multiprobe Calibration Gas Sequencer operates under the control of the CRE, IFT, or digital electronics package. When the electronics package initializes automatic calibration, the solenoid controlling the selected probe is energized. Next, the solenoid controlling calibration gas 1 (high O₂) energizes allowing calibration gas 1 to flow to that probe. After the probe measures the oxygen concentration of calibration gas 1, the gas solenoid is deenergized. An operator selected time delay allows the gas to clear the system. Next, the solenoid controlling calibration gas 2 (low O₂) energizes and allows calibration gas 2 to flow to the probe. After the probe measures the oxygen concentration of calibration gas 2, the gas and probe solenoids deenergize. The automatic calibration is now complete for the probe selected.

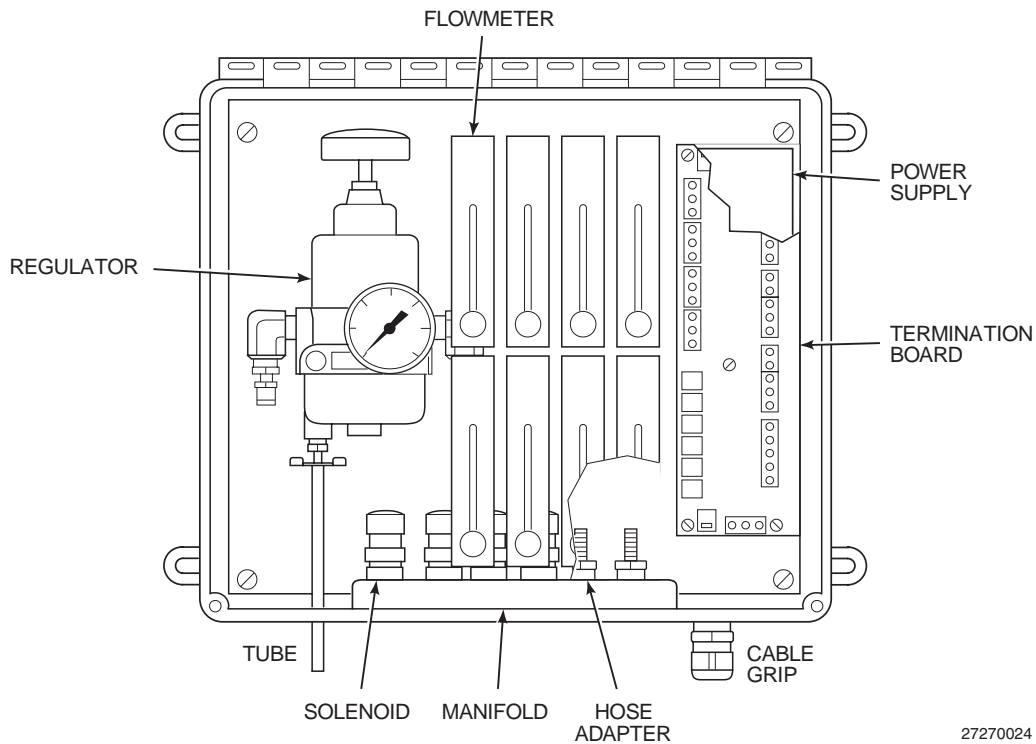
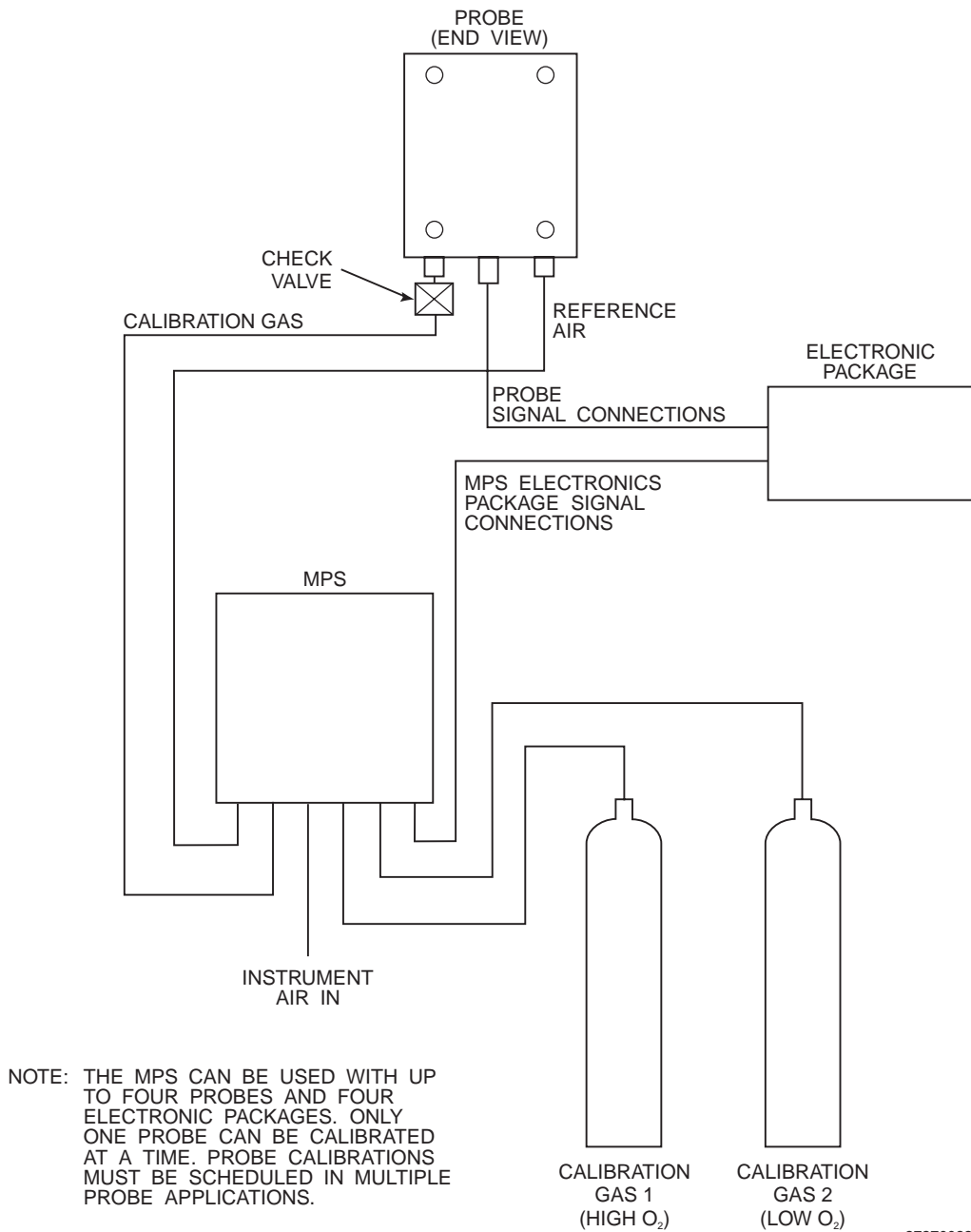

Figure D-2. Multiprobe Calibration Gas Sequencer, Interior

Table D-1. Specifications for Multiprobe Calibration Gas Sequencer.

Environmental Classification	NEMA 4X (IP56)
Humidity Range	95% Relative Humidity
Humidity Range	95% Relative Humidity
Ambient Temperature Range	-20° to 160°F (-30° to 71°C)
Vibration.....	5 m/sec ² , 10 to 500 xyz plane
External Electrical Noise.....	Minimum Interference
Piping Distance Between MPS 3000 and Probe	Maximum 300 feet (91 m)
Cabling Distance Between MPS 3000 and Electronics Package.....	Maximum 1000 feet (303 m)
In Calibration Status Relay	48V max, 100 mA max
Cabling Distance Between MPS 3000 and Status Relay Indicator	Maximum 1000 feet (303 m)
Approximate Shipping Weight	35 pounds (16 kg)



27270022

Figure D-3. Typical Automatic Calibration System

NOTE: DIMENSIONS ARE IN INCHES WITH MILLIMETERS IN PARENTHESES.

PARTS LIST		PARTS LIST UNITS: INCHES		GROUP NOTE	
NOTE	DEFINER	MAT'L CODE	PART NUMBER	OR REF DWG	GROUP
ITEM	PART NAME	DWG	AML	W/O PRESSURE LOSS SWITCH	W/ PRESSURE LOSS SWITCH
01	MPS ASSEMBLY	4	3D39425GXX	A/R	A/R
02	Z-PURGE UNIT		1A98474H01	1	1
03	Z-PURGE UNIT		1A98474H02		1
04	TUBE FITTING		771B870H05	2	2

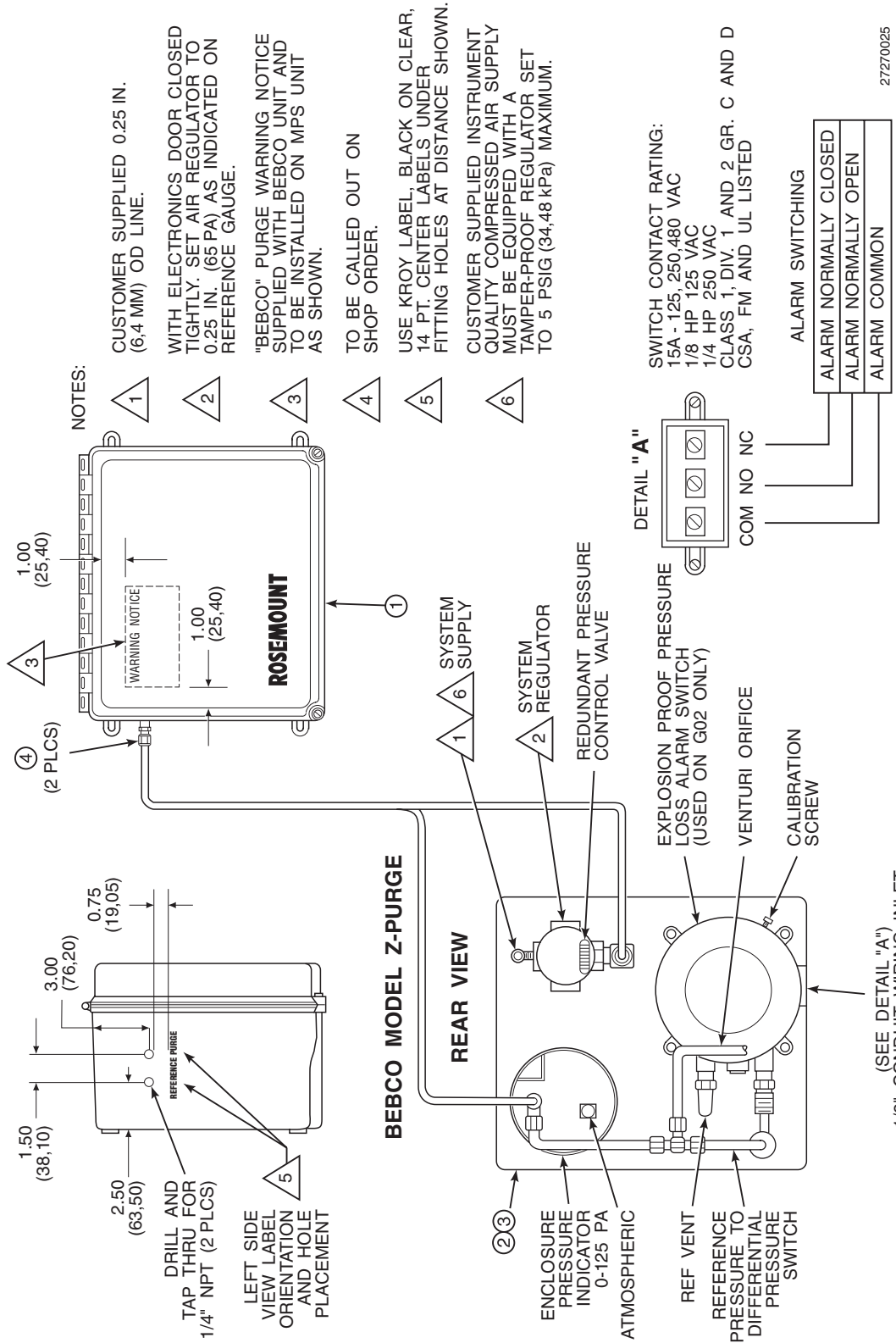

Figure D-4. MPS with Z-Purge

27270025

MPS 3000 TROUBLESHOOTING

D-3 OVERVIEW

This section describes troubleshooting for the Multiprobe Calibration Gas Sequencer. Additional troubleshooting information can be found in the Instruction Bulletin for the electronics package.

WARNING

Install all protective equipment covers and safety ground leads after troubleshooting. Failure to replace covers and ground leads could result in serious injury or death.

D-4 TROUBLESHOOTING

Table D-2 provides a guide to fault finding failures within the MPS. The flowchart in Figure D-5 provides an alternate approach to fault finding MPS related problems.

Table D-2. Fault Finding

SYMPTOM	CHECK	FAULT	REMEDY
1. Power to solenoid, calibration gas not released to probe.	Calibration gas	Insufficient calibration gas	Install new calibration gas tanks.
	Solenoid	Solenoid failure	Replace solenoid.
2. No power to solenoid.	Power supply output	Power supply failure	Replace power supply.
	Fuses in power supply	Fuse blown	Replace fuse.
	Main power source	Main power off	Reestablish power.

SYMPTOM

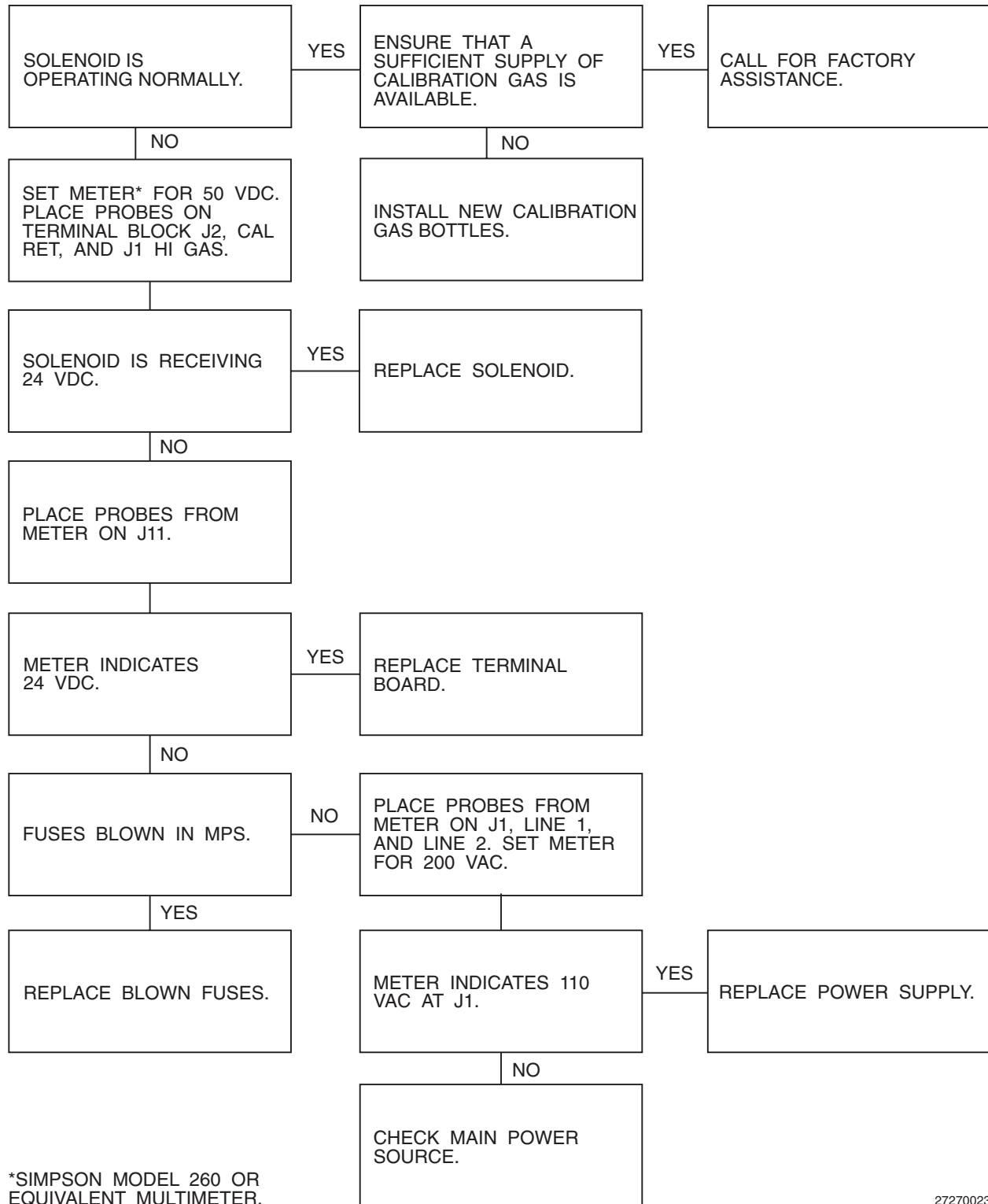

27270023

Figure D-5. MPS Troubleshooting Flowchart

SERVICE AND NORMAL MAINTENANCE

D-5 OVERVIEW

This section describes service and routine maintenance of the MPS 3000 Multiprobe Calibration Gas Sequencer. Replacement parts referred to are available from Rosemount. Refer to Table D-3 for part numbers and ordering information.

WARNING

Install all protective equipment covers and safety ground leads after equipment repair or service. Failure to install covers and ground leads could result in serious injury or death.

D-6 FUSE REPLACEMENT

Power supply (58, Figure D-6) contains two identical 1 amp fuses (3). Perform the following procedure to check or replace a fuse.

WARNING

Disconnect and lock out power before working on any electrical components.

- Turn off power to the system.
- Unscrew top of fuseholder (40) and remove the fuse. Refer to Table D-3 for replacement fuse specifications. After checking or replacing a fuse, reinstall top of fuseholder.

D-7 POWER SUPPLY REPLACEMENT

WARNING

Disconnect and lock out power before working on any electrical components.

- Turn off power to the system.
- Loosen two captive screws holding the MPS cover (15, Figure D-6). Open the MPS cover.
- Loosen two captive screws holding the inner cover (16). Lower the inner cover.
- Disconnect the 24V connector from J11 on the termination board (34).

- Remove two screws (39) and washers (38) holding the terminal cover (37). Remove the terminal cover.
- Tag and remove wires from terminals 1 and 4 or 5 of the transformer in the power supply (58).
- Remove two nuts (60) and washers (59) from the screws holding the power supply (58). Remove the power supply.
- Mount the new power supply onto the screws with two nuts (60) and washers (59). Make sure the ground wires are connected to the upper mounting screw.
- Reconnect the wires removed in step f.
- Install the terminal cover (37) with two screws (38) and washers (39).
- Connect the 24V connector to J11 on the termination board (34).
- Close and secure the inner cover (16) with two captive screws. Close and secure the outer cover (15) with two captive screws.

D-8 SOLENOID VALVE REPLACEMENT

An MPS 3000 will always have a HI GAS solenoid (63, Figure D-6) and a LOW GAS solenoid (64) mounted to the manifold (11). Each probe will also have a solenoid valve (9) mounted on the manifold.

WARNING

Disconnect and lock out power before working on any electrical components.

- Turn off power to the system.
- Loosen two captive screws holding the MPS cover (15, Figure D-6). Open the MPS cover.
- Loosen two captive screws holding the inner cover (16). Lower the inner cover.
- Disconnect the HI GAS (J17), LOW GAS (J18), or Probe (J13-J16) plug from its receptacle on the termination board (34).

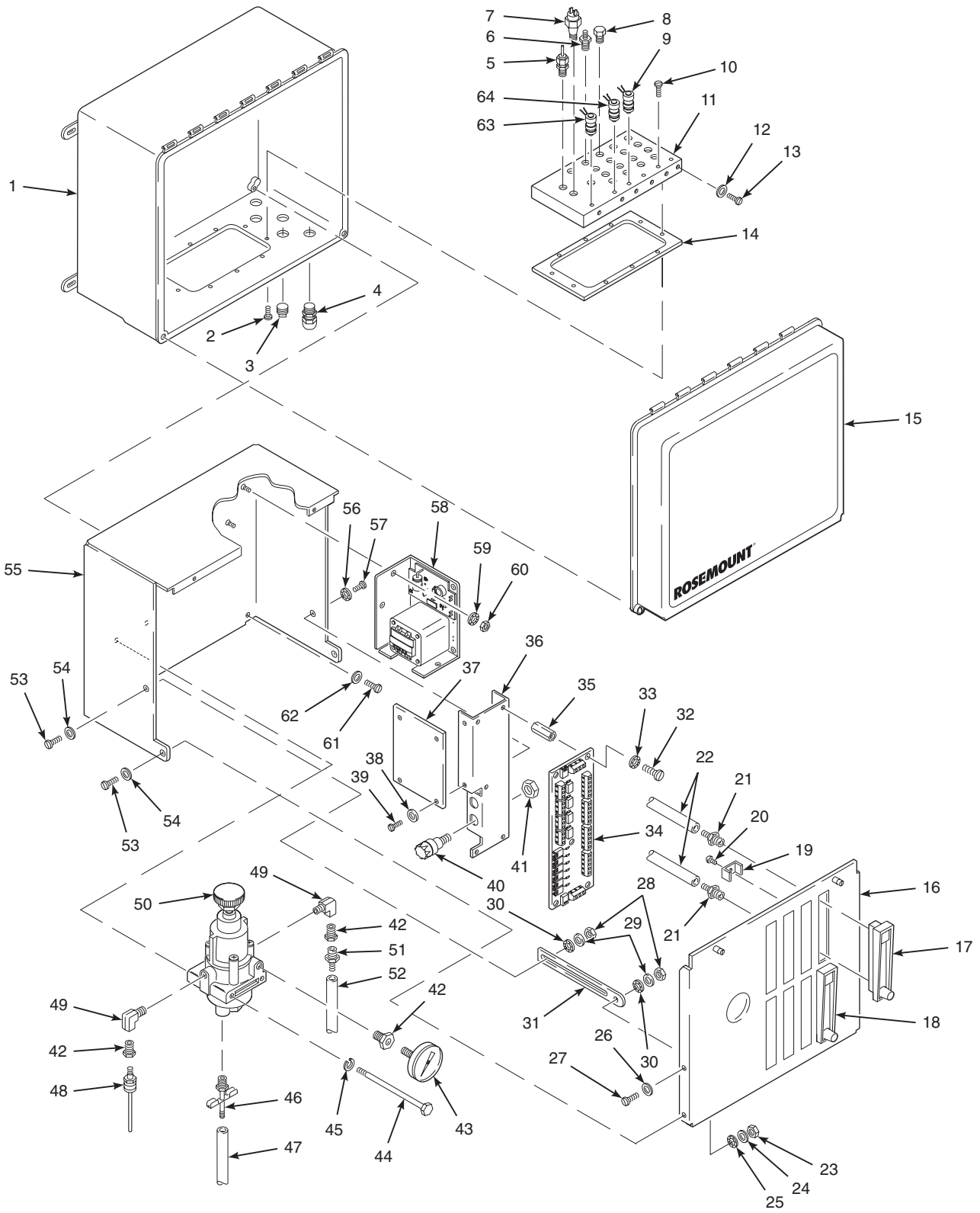

Figure D-6. Multiprobe Calibration Gas Sequencer, Exploded View

LEGEND FOR FIGURE D-6

1. Enclosure	23. Nut	45. Washer
2. Screw	24. Lockwasher	46. Drain Valve
3. Plug	25. Washer	47. 1/8 in. Impolene Tubing
4. Cable Grip	26. Washer	48. Connector
5. Fitting	27. Screw	49. Elbow
6. Hose Adapter	28. Nut	50. Pressure Regulator
7. Pressure Switch	29. Washer	51. Hose Adapter
8. Plug	30. Washer	52. 1/4 in. Tube
9. Solenoid Valve	31. Cover Stop Slide	53. Screw
10. Screw	32. Screw	54. Washer
11. Manifold	33. Washer	55. Inner Enclosure
12. Washer	34. Termination Board	56. Washer
13. Screw	35. Standoff	57. Screw
14. Gasket	36. Mounting Bracket	58. Power Supply
15. Outer Cover	37. Cover Plate	59. Washer
16. Inner Cover	38. Washer	60. Nut
17. Flowmeter, 10 SCFH	39. Screw	61. Screw
18. Flowmeter, 2.0 SCFH	40. Fuseholder	62. Washer
19. Bracket	41. Plastic Nut	63. Solenoid
20. Screw	42. Bushing	64. Solenoid
21. Hose Adapter	43. Pressure Gauge	
22. 1/8 in. Hose	44. Bolt	

- e. Loosen the retaining ring in the middle of the solenoid and remove the top part.
- f. With a spanner wrench or padded pliers, remove the remaining part of the solenoid from the manifold (11).
- g. Separate the new solenoid and screw the smaller part into the manifold.
- h. Place the top part of the solenoid into position and tighten the retaining ring.
- i. Connect the plug to the proper receptacle on the termination board (34).
- j. Close and secure the inner cover (16) with two captive screws. Close and secure the outer cover (15) with two captive screws.

D-9 PRESSURE REGULATOR MAINTENANCE

a. Pressure Adjustments

Pressure regulator (50, Figure D-6) is factory set to 20 psi (138 kPa). Should the pressure need to be changed or adjusted, use the knob on top of the pressure regulator.

b. Condensation Drain

To drain excess moisture from the internal gas circuit of the MPS, periodically loosen drain valve (46) on the bottom of pressure regulator (50). The moisture will flow through vinyl tubing drain (47) on the bottom of pressure regulator (50) and exit the bottom of MPS enclosure (1).

D-10 FLOWMETER ADJUSTMENTS

There are two flowmeters per flowmeter assembly. The top flowmeter is factory set to 5 scfh. The bottom flowmeter is set to 2 scfh. Should the flow need to be changed or adjusted, use knob on the bottom of the respective flowmeter.

D-11 ADDING PROBES TO THE MPS

This procedure is used to add a probe to the MPS.

WARNING

Disconnect and lock out power before working on any electrical components.

- a. Turn off power to the system.
- b. Loosen the two captive screws holding the MPS cover (15). Lift the cover.
- c. Loosen the two captive screws that hold the inner cover (16) and lower the cover.
- d. From the backside of the inner cover, locate the flowmeter positions next to the existing unit(s). Insert a hacksaw blade into the slots surrounding the positions for two flowmeters, and saw out the knockout tabs.
- e. From the front of the inner cover, install a flowmeter (P/N 771B635H01) into the top hole and a flowmeter (P/N 771B635H02) into the bottom hole. From the backside secure with brackets provided.
- f. Remove four brass screw plugs (CAL GAS IN, CAL GAS OUT, REF AIR IN, and REF AIR OUT) for the next probe position in the manifold.
- g. Install 1/8" hose adapters (P/N 1A97553H01) into the empty holes using a suitable pipe dope. Attach the tubing.
- h. Remove a brass screw plug (P/N 1A97900H01) and install a solenoid (P/N 3D39435G01). Make sure the O-ring seals properly.
- i. Attach the hoses to the flowmeter using the existing installation as a guide. Support the flowmeter while attaching the hose.
- j. Install the solenoid wire connector into the proper position (J14-J16) on the termination board (34).
- k. Close and secure the inner cover (16) with two captive screws. Close and secure the outer cover (15) with two captive screws.

REPLACEMENT PARTS

Table D-3. Replacement Parts for the Multiprobe Test Gas Sequencer

FIGURE and INDEX No.	PART NUMBER	DESCRIPTION
Figure D-6, 58	1A97909H01*	Power Supply
Figure D-6, 9	3D39435G01**	Solenoid Valve
Figure D-6, 40	138799-004	Fuse, fast acting, 1A @ 250 Vac, size: 1/4" Dia. x 1-1/4" Lg., glass body, non time delay, Bussman part no. BK/AGC-1
Figure D-6, 40	138799-014	Fuse, fast acting, 0.5A @ 250 Vac, size: 1/4" Dia. x 1-1/4" Lg., glass body, non time delay, Bussman part no. BK/AGC-1/2
Figure D-6, 17	771B635H01**	Flowmeter Assembly - Calibration Gas
Figure D-6, 18	771B635H02**	Flowmeter Assembly - Reference Air
	1A98631	Probe Adder Kit
Figure D-6, 51	1A97953H01**	Hose Adapter
	4847B46H01**	Tubing Length
	4847B46H02**	Tubing Length
	4847B46H03**	Tubing Length
	4847B46H04**	Tubing Length
Figure D-3	7307A56G02	Check Valve

*Specify line voltage and probe type when ordering.

** These items are included in the probe adder kit.

APPENDIX E, REV. 4.5

IFT 3000 INTELLIGENT FIELD TRANSMITTER

DESCRIPTION

WARNING

Read the "Safety instructions for the wiring and installation of this apparatus" at the front of this Instruction Bulletin. Failure to follow the safety instructions could result in serious injury or death.

E-1 DESCRIPTION

The Rosemount IFT 3000 Intelligent Field Transmitter (IFT), Figure E-1, provides all necessary intelligence for controlling a probe and the optional Multiprobe Calibration Gas Sequencer. The IFT provides a user-friendly, menu-driven operator interface with context-sensitive, on-line help. The IFT may also be used without an HPS.

The IFT is based on a modular design. There is a maximum total of four PC boards within the IFT. Every IFT contains a microprocessor board, a power supply board, and an interconnect board. In addition to these boards, deluxe version IFTs also contain a General User Interface/LED display board.

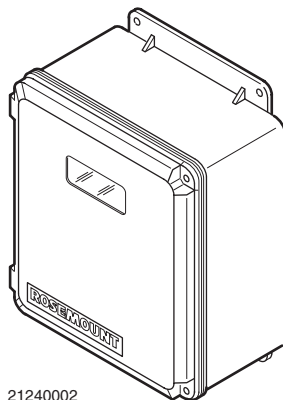

21240002

Figure E-1. IFT 3000 Intelligent Field Transmitter

IFTs with no displays are known as "blind" units. Blind IFTs also lack a General User Interface (GUI) and must be controlled with an external HART communications device.

a. Microprocessor Board

The microprocessor board contains, EEPROM, RAM, and a timer. The microprocessor board also controls the probe heater. The IFT can be used in conjunction with or without an optional HPS 3000 Heater Power Supply providing power to the heater depending upon the user's application.

b. Interconnect Board

The interconnect board is used for all communications from the IFT to the other components within the system. These other components may include an optional HPS 3000 Heater Power Supply, optional MPS Multiprobe Calibration Gas Sequencer, World Class 3000 Probe (non-HPS equipped system), analog output, and relay outputs.

c. Power Supply Board

The power supply board is user configurable for five different line voltages to include 100, 120, 220, and 240 Vac. In addition, the output voltage for a probe heater is also configurable if used in a non-HPS equipped system.

d. GUI/LED Display Board (Optional)

The GUI/LED display board, which is part of the GUI assembly, has a 4-line by 20-character liquid crystal display and eight membrane keys. The board also contains an LED display which indicates the current O₂ value. The LED display has indicator LEDs for calibration gas high (TGH), calibration gas low (TGL) and calibrating (CAL).

e. Heater (optional)

A heater is available for ambient conditions below 32°F (0°C).

f. Z-Purge (optional)

A Z-purge arrangement is available for applications requiring hazardous area classification. See Application Data Bulletin AD 106-300B.

of the cell. If the temperature of the cell becomes too high, the IFT will disable the HPS.

A cold junction temperature compensation feature ensures an accurate probe thermocouple reading. A temperature sensor in the heater power supply monitors the temperature at the junction between the compensated cable running to the probe and the uncompensated cable running to the IFT. The voltage from this sensor is used by the IFT to compensate the probe thermocouple readings for the temperature at the junction.

E-2 THEORY OF OPERATION

A functional block diagram of the IFT, connected to the HPS and probe, is shown in Figure E-2. In operation, the IFT monitors the temperature of the cell by means of the probe thermocouple. The IFT controls the temperature

The cell signal is a voltage proportional to the oxygen concentration difference between the two sides of the cell. The IFT receives this signal and translates it into a user-specified form for display and/or output.

Table E-1. Specifications for Intelligent Field Transmitter

Environmental Classification	NEMA 4X (IP56)
Humidity Range.....	95% Relative Humidity
Ambient Temperature Range.....	-20° to 122°F (-30° to 50°C)
Vibration	5 m/sec ² , 10 to 500 xyz plane
Electrical Noise Immunity Standard	EN 50 082-1
Electrical Noise Radiated Emission Standard.....	EN 55 011
Installation Category	Overvoltage Category II (IEC 664)
HART Communications.....	Modulated on a 4-20 mA analog output, only
Analog Outputs	isolated, 0-20 mA, 4-20 mA, 0-10 V, 20-0 mA, 20-4 mA, or 10-0 V output
O ₂ Accuracy (analog output).....	0.1% O ₂ or ±3% of reading, whichever is greater using Hagan calibration gases
O ₂ Range.....	Field Selectable 0-40% (linear or logarithmic)
Power Supply	100/120/220/240 ±10% Vac at 50/60 Hz.
Power Requirements.....	(w/HPS 3000): 30 Watts (VA); (w/Model 218 Probe): 275 VA (w/WC 3000 Probe): 275 Watts (VA)
Output Resolution	11 bits (1 bit = 0.05% of output F.S.)
System Speed of Response (amplifier output)	less than 3 seconds
Resolution Sensitivity - Transmitted Signal.....	0.01% O ₂
Deadman Contact Output	Form-C, 48 Volt max, 100 mA max
Programmable Contact Outputs	2 available, Form-C, 48 V max, 100 mA max
GUI/LED Display Board (optional)	1, with 0.8 in. (20 mm) high, 3-character, alphanumeric LED display 4-line by 20-character backlight LCD alpha-numeric display; 8-key general purpose keyboard, or HART device
Approximate Shipping Weight.....	25 lbs (11 kg)

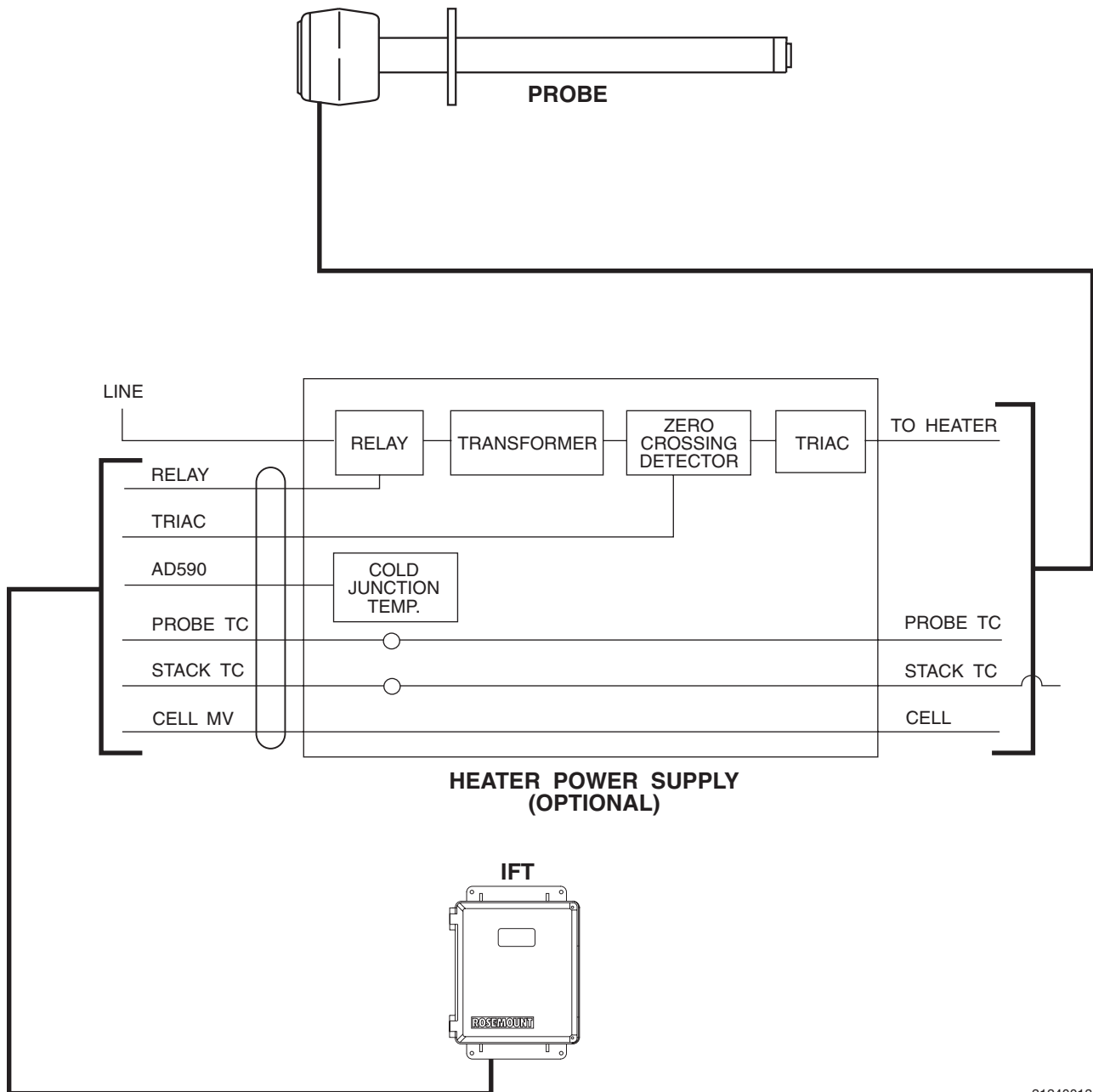

21240013

Figure E-2. System Block Diagram

IFT 3000 TROUBLESHOOTING

E-3 OVERVIEW

The IFT troubleshooting section describes how to identify and isolate faults which may develop in the IFT.

WARNING

Install all protective equipment covers and safety ground leads after troubleshooting. Failure to replace covers and ground leads could result in serious injury or death.

E-4 IFT TROUBLESHOOTING

IFT troubleshooting is achieved by determining the functional status of the microprocessor board and interpreting status displays on the front panel.

a. Microprocessor Status LED

The microprocessor board includes an LED to aid in isolating equipment faults. LED indications are as follows:

1. LED OFF. IFT failure, or power is removed; refer to Troubleshooting Flow-chart #1 (Figure E-3).
2. LED ON - STEADY. Heater system failure; refer to Troubleshooting Flow-chart #2 (Figure E-4).
3. LED ON - FLASHING. Microprocessor normal.

b. Equipment Status (LCD) Displays

The status line of the GUI equipped IFT will display one system status display (one at a

time) in priority sequence, as indicated in the following list. To troubleshoot an equipment fault, refer to COMPONENT FAILURE indications applicable to the display message (SYMPTOM) in Table E-2.

1. **Off** - The probe has been turned off because the IFT cannot control the heater temperature.
2. **Param** - IFT has been unlocked using the user's password.
3. **Serv** - IFT has been unlocked using the service password.
4. **PrbEr** - The probe is disconnected, cold, or leads are reversed.
5. **HtrEr** - If HtrEr is displayed, there is a fault within the heater system.
6. **InCal** - If InCal is displayed, the system is currently undergoing calibration.
7. **LowO₂** - If LowO₂ is displayed, the O₂ value is below the low alarm limit.
8. **HiO₂** - If HiO₂ is displayed, the O₂ value is above the high alarm limit.
9. **NoGas** - If NoGas is displayed, there is no calibration gas pressure.
10. **CalEr** - If CalEr is displayed, an error was detected during the calibration process.
11. **ResHi** - If ResHi is displayed, the cell resistance is above the high limit.
12. **OK** - If OK is displayed, the system is operating normally.

SYMPTOM - MICROPROCESSOR BOARD LED IS OFF

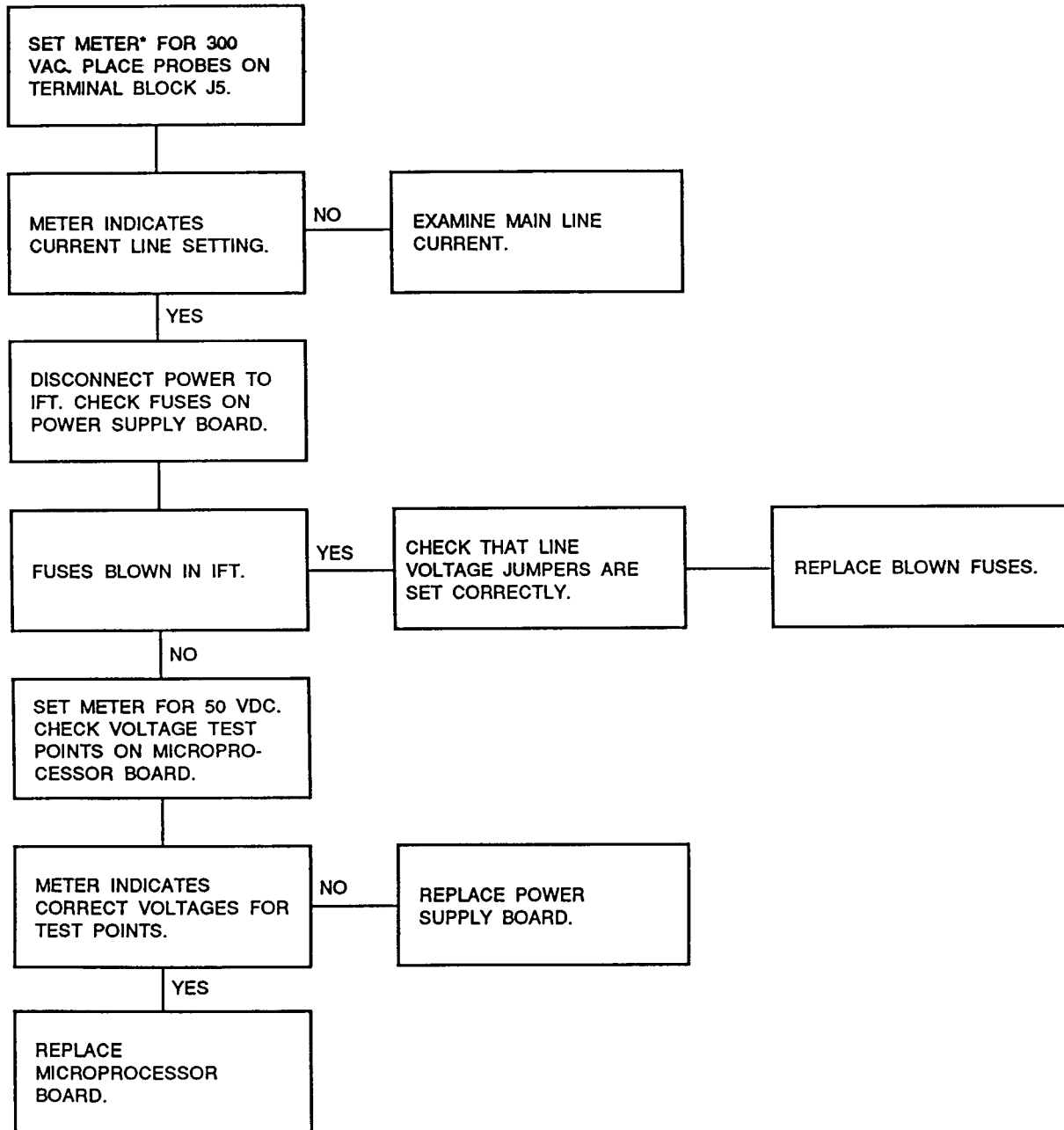

*SIMPSON MODEL 260 OR EQUIVALENT MULTIMETER.

Figure E-3. IFT Troubleshooting Flowchart, #1

SYMPTOM - MICROPROCESSOR BOARD LED IS STEADY ON

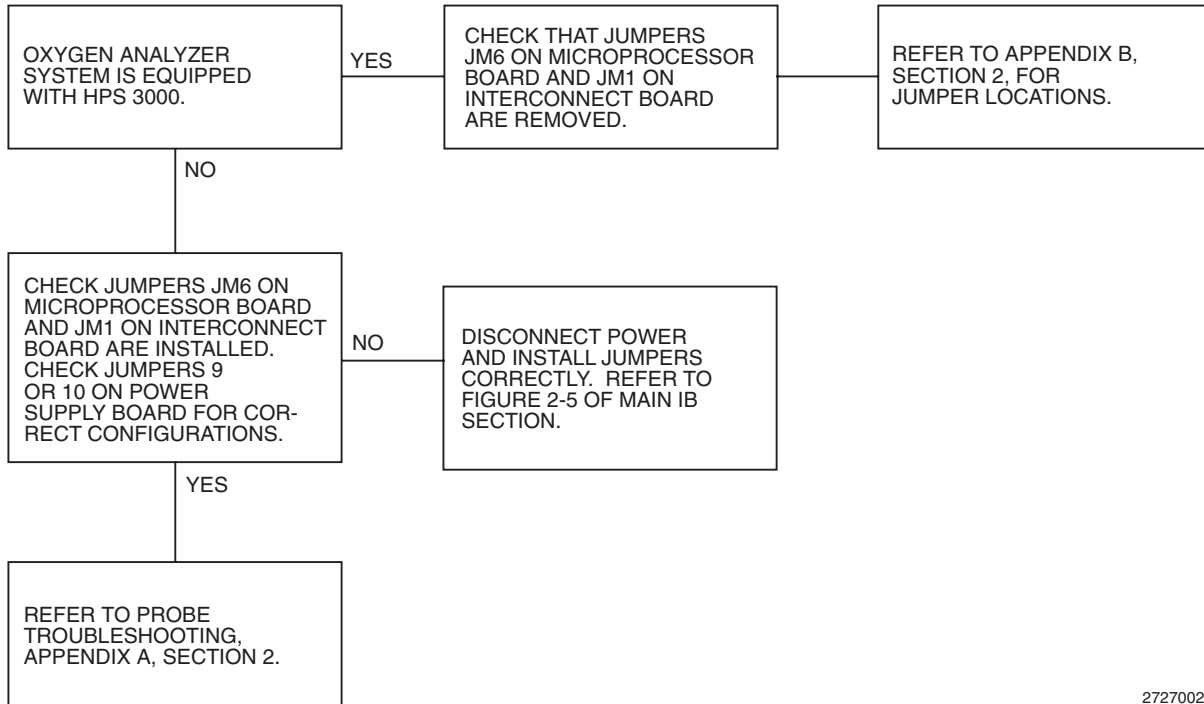

27270021

Figure E-4. IFT Troubleshooting Flowchart, #2

END OF FLOWCHART #2

SYMPTOM - GENERAL USER INTERFACE OR LED DISPLAY PANEL DOES NOT FUNCTION

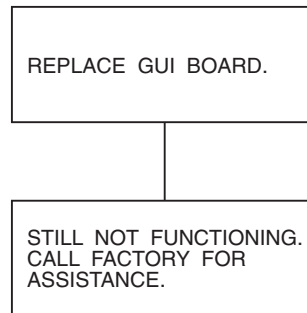

27270020

Figure E-5. IFT Troubleshooting Flowchart, #3

Table E-2. GUI Equipped IFT Fault Finding

SYMPTOM	COMPONENT FAILURE
1. Display is blank.	Possible failure within IFT. Check LED on microprocessor board.
2. CalEr is displayed.	Repeat calibration sequence. If error persists, troubleshoot major components.
3. HtrEr is displayed.	Ensure jumpers are set correctly on IFT. If system is equipped with HPS refer to HPS 3000 Troubleshooting in Appendix B for additional troubleshooting procedures.
4. NoGas is displayed.	Possible failure within the MPS. Refer to MPS 3000 Troubleshooting in Appendix D for additional troubleshooting procedures.
*5. HiO ₂ is displayed.	Possible failure within the probe. Ensure the high alarm level has been entered correctly. Refer to Probe Troubleshooting in Appendix A for additional troubleshooting procedures.
*6. LowO ₂ is displayed.	Possible failure within the probe. Ensure the low alarm parameter has been entered correctly. Refer to Probe Troubleshooting in Appendix A for additional troubleshooting procedures.
7. ResHi is displayed.	Cell resistance has exceeded upper limit. Ensure resistance value has been entered correctly. Refer to Probe Troubleshooting in Appendix A for additional troubleshooting procedures.
8. Off	The probe has been turned OFF because the IFT cannot control the heater temperature.
9. PrbEr	The probe is disconnected, cold, or leads are reversed.

*HiO₂ and LowO₂ can occur in the system without system failure.

SERVICE AND NORMAL MAINTENANCE

E-5 OVERVIEW

This section describes service and routine maintenance of the Intelligent Field Transmitter. Replacement parts referred to are available from Rosemount. Refer to Replacement Parts later in this appendix for part numbers and ordering information.

WARNING

Install all protective equipment covers and safety ground leads after equipment repair or service. Failure to install covers and ground leads could result in serious injury or death.

E-6 FUSE REPLACEMENT

Power supply board (4, Figure E-6) contains four identical 5 amp fuses.

Perform the following procedure to check or replace a fuse. In addition, 2 additional 5 amp fuses (F1 and F2) are included if the IFT unit has an internal heater installed.

WARNING

Disconnect and lock out power before working on any electrical components. There is voltage up to 240 Vac, and could cause personal injury.

- a. Turn off power to the system.
- b. Open cover door (16) of the IFT by removing screws (17).
- c. Remove protective cover (13) by removing screws (14) and washers (15).
- d. Unscrew fuseholder top and remove the fuse (5). After checking or replacing a fuse, reinstall the fuseholder top.
- e. Replace protective cover (13) and secure with washers (15) and screws (14).

- f. Close cover door (16) and secure with screws (17).

E-7 TRANSFORMER REPLACEMENT

WARNING

Disconnect and lock out power before working on any electrical components. There is voltage up to 240 Vac, and could cause personal injury.

- a. Turn off power to the system.
- b. Open cover door (16) of the IFT by removing screws (17).
- c. Remove protective cover (13) by removing screws (14) and washers (15).
- d. Disconnect cable (1) from the receptacle on microprocessor board (11). Disconnect GUI assembly cable from receptacles on microprocessor board if IFT is equipped with GUI.
- e. Carefully tagging wires, remove the wires from terminal strip on interconnect board (12).
- f. If unit is equipped with heater option, remove thermoswitch assembly (18, 19, Figure E-8) by removing screws (13) and washers (14).
- g. Remove mounting plate (10) by removing the necessary screws.
- h. Disconnect transformer cable plugs from the receptacles on power supply board (4).
- i. Remove transformer (9) from enclosure (6) by removing four screws (8).
- j. Attach new transformer to enclosure (6) with four screws (8).
- k. Connect the transformer cable plugs from transformer (9) to the receptacles on power supply board (4).

1. Cable
2. Machine Screw, M3 x 8 mm
3. Lockwasher, 3 mm (Note 2)
4. Power Supply Board
5. Fuses, 5 Amp
6. Enclosure
7. Plug
8. Machine Screw, M5 x 8 mm
9. Transformer
10. Mounting Plate
11. Microprocessor Board
12. Interconnect Board
13. Protective Cover
14. Screw, M4
15. Washer
16. Cover Door
17. Screw, M4
18. Pin
19. Nylon Washer (Note 2)
20. O-Ring
21. Nylon Washer

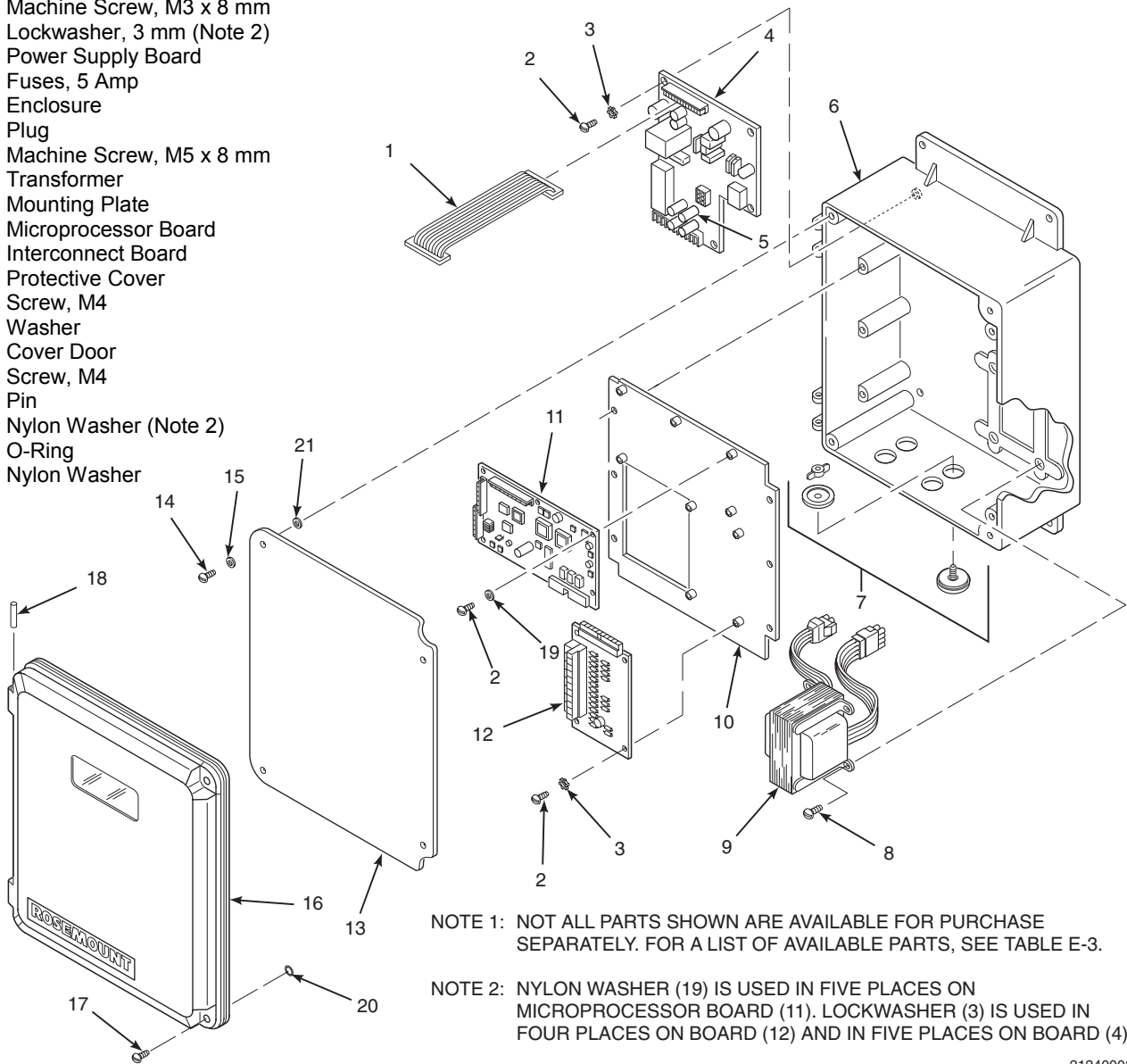

NOTE 1: NOT ALL PARTS SHOWN ARE AVAILABLE FOR PURCHASE SEPARATELY. FOR A LIST OF AVAILABLE PARTS, SEE TABLE E-3.

NOTE 2: NYLON WASHER (19) IS USED IN FIVE PLACES ON MICROPROCESSOR BOARD (11). LOCKWASHER (3) IS USED IN FOUR PLACES ON BOARD (12) AND IN FIVE PLACES ON BOARD (4).

21240003

Figure E-6. Intelligent Field Transmitter, Exploded View

- l. Reinstall mounting plate (10) to enclosure (6) with the necessary screws and washers.
- m. If removed, replace thermoswitch assembly (18, 19, Figure E-8) and secure with screws (13) and washers (14).
- n. Reinstall the wires to the terminal strip on interconnect board (12) as was noted in step e.
- o. Connect cable (1) to the receptacle on microprocessor board (11). Reconnect GUI assembly cable to receptacles on microprocessor board if IFT is equipped with GUI.
- p. Replace protective cover (13) and secure with washers (15) and screws (14).
- q. Close cover door (16) and secure with screws (17).

E-8 POWER SUPPLY BOARD REPLACEMENT

<p>WARNING</p> <p>Disconnect and lock out power before working on any electrical components. There is voltage up to 240 Vac, and could cause personal injury.</p>

- a. Turn off power to the system.
- b. Open cover door (16) of the IFT by removing screws (17).
- c. Remove protective cover (13) by removing screws (14) and washers (15).
- d. Disconnect cable (1) from the receptacle on microprocessor board (11). Disconnect GUI assembly cable from receptacles on microprocessor board if IFT is equipped with GUI.
- e. Carefully tagging wires, remove the wires from terminal strip on interconnect board (12).
- f. If unit is equipped with heater option, remove thermoswitch assembly (18, 19, Figure E-8) by removing screws (13) and washers (14).

- g. Remove mounting plate (10) by removing the necessary screws.
- h. If unit is equipped with heater option, disconnect plug from J2 on power supply board (4, Figure E-6) by squeezing tabs in and pulling connector up.
- i. If unit is equipped with heater option, remove fan assembly (7, 10, Figure E-8) by removing screws (5) and washers (6).
- j. Disconnect the transformer cable plugs from the receptacles on power supply board (4, Figure E-6).
- k. Carefully tagging wires, remove the wires from terminal strips J5 and J6 on power supply board (4, Figure E-6).
- l. Remove power supply board (4) from enclosure (6) by removing screws (2) and washers (3).
- m. Attach new power supply board (4) to enclosure (6) with screws (2) and washers (3).
- n. Reconnect the wires as noted in step e.
- o. Connect the transformer cable plugs from transformer (9) to the receptacles on power supply board (4).
- p. If removed, install fan assembly (7, 10, Figure E-8) and secure with screws (5) and washers (6).
- q. If disconnected, reconnect plug to J2 on power supply board (4, Figure E-6).
- r. If removed, replace thermoswitch assembly (18, 19, Figure E-8) and secure with screws (13) and washers (14).
- s. Reinstall mounting plate (10) to enclosure (6) using the necessary screws.
- t. Reconnect the wires to interconnect board (12) as noted in step e.

World Class 3000

- u. Connect cable (1) to the receptacle on microprocessor board (11). Reconnect GUI assembly cable to receptacles on microprocessor board if IFT is equipped with GUI.
- v. Replace protective cover (13) and secure with washers (15) and screws (14).
- w. Close cover door (16) and secure with screws (17).

- h. Reconnect cable (1) to receptacle on microprocessor board. Reconnect GUI assembly cable to receptacles on microprocessor board if IFT is equipped with GUI.
- i. Replace protective cover (13) and secure with washers (15) and screws (14).
- j. Close cover door (16) and secure with screws (17).

E-9 MICROPROCESSOR BOARD REPLACEMENT

E-10 INTERCONNECT BOARD REPLACEMENT

WARNING

Disconnect and lock out power before working on any electrical components. There is voltage up to 240 Vac, and could cause personal injury.

WARNING

Disconnect and lock out power before working on any electrical components. There is voltage up to 240 Vac, and could cause personal injury.

- a. Turn off power to the system.
- b. Open cover door (16) of the IFT by removing screws (17).
- c. Remove protective cover (13) by removing screws (14) and washers (15).
- d. Disconnect cable (1) from the receptacle on microprocessor board (11). Disconnect GUI assembly cable from receptacles on microprocessor board if IFT is equipped with GUI.
- e. Remove microprocessor board (11) by removing screws (2) and nylon washers (19).

- a. Turn off power to the system.
- b. Open cover door (16) of the IFT by removing screws (17).
- c. Remove protective cover (13) by removing screws (14) and washers (15).
- d. Carefully tagging wires, remove the wires from terminal strip on interconnect board (12).
- e. Remove interconnect board (20) by removing screws (2) and washers (3).

CAUTION

Pull up very carefully on the microprocessor board to ensure that none of the pins in the connection between the microprocessor board and interconnect board are damaged.

CAUTION

Pull down very carefully on the interconnect board to ensure that none of the pins in the connection between the microprocessor board and interconnect board are damaged.

- f. Connect the new microprocessor board (11) to the interconnect board (12) by carefully lining up the pins on the plug.
- g. Attach microprocessor board (11) to mounting plate (10) with screws (2) and nylon washers (19).

- f. Connect new interconnect board (12) to the microprocessor board by carefully lining up the pins on the plug.
- g. Attach interconnect board (12) to mounting plate (10) with screws (2) and washers (3).
- h. Reconnect wires to the terminal strip as noted in step d.

- i. Replace protective cover (13) and secure with washers (15) and screws (14).
- j. Close cover door (16) and secure with screws (17).

E-11 GUI ASSEMBLY REPLACEMENT

These replacement instructions are provided for GUI equipped systems. Refer to Figure E-7.

CAUTION

Disconnect and lock out power before working on any electrical components. There is voltage up to 240 Vac, and could cause personal injury.

- a. Turn off power to the system.
- b. Open cover door (43, Figure E-7) of the IFT by removing screws (5).

- | | |
|-----------------|---------------|
| 1. Screw | 4. Cover Door |
| 2. Washer | 5. Screw, M4 |
| 3. GUI Assembly | 6. O-Ring |

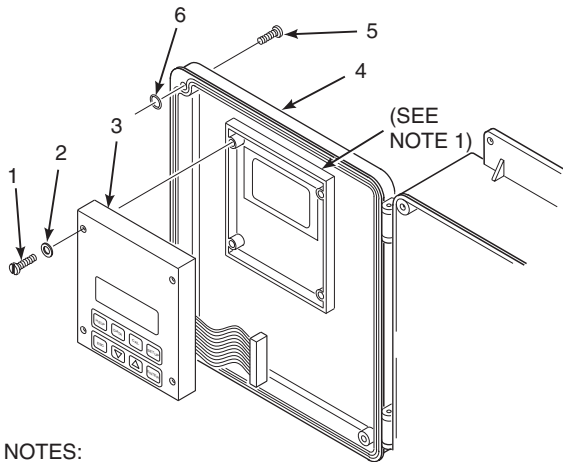

NOTES:

- 1. GUI MOUNT AREA IS PART OF COVER DOOR.
- 2. GUI FACES INSIDE OF IFT ENCLOSURE WHEN COVER DOOR IS CLOSED.
- 3. NOT ALL PARTS SHOWN ARE AVAILABLE FOR PURCHASE SEPARATELY. FOR A LIST OF AVAILABLE PARTS, SEE TABLE E-3.

21240001

Figure E-7. Replacing the GUI Assembly

- c. Disconnect GUI assembly cables from microprocessor board (11, Figure E-6).
- d. Remove GUI assembly (3, Figure E-7) by removing screws (1) and washers (2).
- e. Attach new GUI assembly to inside of cover door (4) with washers (2) and screws (1).
- f. Reconnect GUI assembly cables to microprocessor board (11, Figure E-6).
- g. Close cover door (4, Figure E-7) and secure with screws (5).

E-12 HEATER / FAN / THERMOSWITCH REPLACEMENT

These replacement instructions are provided for heater/fan/thermoswitch equipped systems.

a. Heater Replacement

WARNING

Disconnect and lock out power before working on any electrical components. There is voltage up to 240 Vac, and could cause personal injury.

- 1. Turn off power to the system.
- 2. Open cover door (1, Figure E-8) of the IFT by removing screws (5, Figure E-7).
- 3. Remove protective cover (4) by removing screws (2) and washers (3).
- 4. Disconnect cable (1, Figure E-6) from microprocessor board (11, Figure E-6).
- 5. Partially remove mounting plate assembly (15) from enclosure (23) by removing necessary screws.
- 6. Remove screws (11) and washers (12) to free heater mounting plate (20) from mounting plate (15).
- 7. Cut wires to old heater (21) close to the heater; then remove old heater from heater mounting plate (20).

8. Splice heater wire to new heater (21) and attach new heater to heater mounting plate (20).
9. Attach heater assembly (20, 21) to mounting plate (15) using screws (11) and washers (12).
10. Reconnect all cables removed in step 3.
11. Position mounting plate (15) onto enclosure (23) and secure with the necessary screws.
12. Reinstall protective cover (15) using screws (2) and washers (3).
13. Close door cover (1) and secure with screws (5, Figure E-7).

b. Thermoswitch Replacement

WARNING

Disconnect and lock out power before working on any electrical components. There is voltage up to 240 Vac, and could cause personal injury.

1. Turn off power to the system.
2. Open cover door (1, Figure E-8) of the IFT by removing screws (5, Figure E-7).
3. Remove protective cover (4) by removing screws (2) and washers (3).
4. Disconnect cable (1, Figure E-6) from microprocessor board (11, Figure E-6).
5. Partially remove mounting plate assembly (15) from enclosure (23) by removing necessary screws.
6. Remove screws (13) and washers (14), and remove thermoswitch mounting plate (18) from mounting plate (15).
7. Pull wires free of thermoswitch tabs.

8. Remove old thermoswitch (19) from thermoswitch mounting plate (18) by removing screws (16) and washers (17).
9. Install new thermoswitch (19) to thermoswitch mounting plate (18) using screws (16) and washers (17).
10. Connect wires to thermoswitch tabs.
11. Attach thermoswitch assembly (18, 19) to mounting plate (15) using screws (13) and washers (14).
12. Reconnect cable removed in step 4.
13. Position mounting plate (15) onto enclosure (23) and secure with the necessary screws.
14. Reinstall protective cover (4) using screws (2) and washers (3).
15. Close door cover (1) and secure with screws (5, Figure E-7).

c. Fan Replacement

WARNING

Disconnect and lock out power before working on any electrical components. There is voltage up to 240 Vac, and could cause personal injury.

1. Turn off power to the system.
2. Open cover door (1, Figure E-8) of the IFT by removing screws (5, Figure E-7).
3. Remove protective cover (4) by removing screws (2) and washers (3).
4. Remove fan mounting bracket (7) from mounting plate (15) by removing screws (5) and washers (6).
5. Remove fan (10) from fan mounting plate (7) by removing screws (9) and washers (8).

6. Cut wires close to old fan (10).
7. Splice wires to new fan (10).
8. Mount new fan (10) to fan mounting bracket (7) using screws (8) and washers (9).
9. Mount fan assembly (7, 10) to mounting plate (15) using screws (5) and washers (6).
10. Reinstall protective cover (4) using screws (2) and washers (3).
11. Close door cover (1) and secure with screws (5, Figure E-7).

NOTES: 1. LETTERS INDICATE WIRE CONTINUITY; A TO A AND B TO B.
2. NOT ALL PARTS SHOWN ARE AVAILABLE FOR PURCHASE SEPARATELY. FOR A LIST OF AVAILABLE PARTS, SEE TABLE E-3.

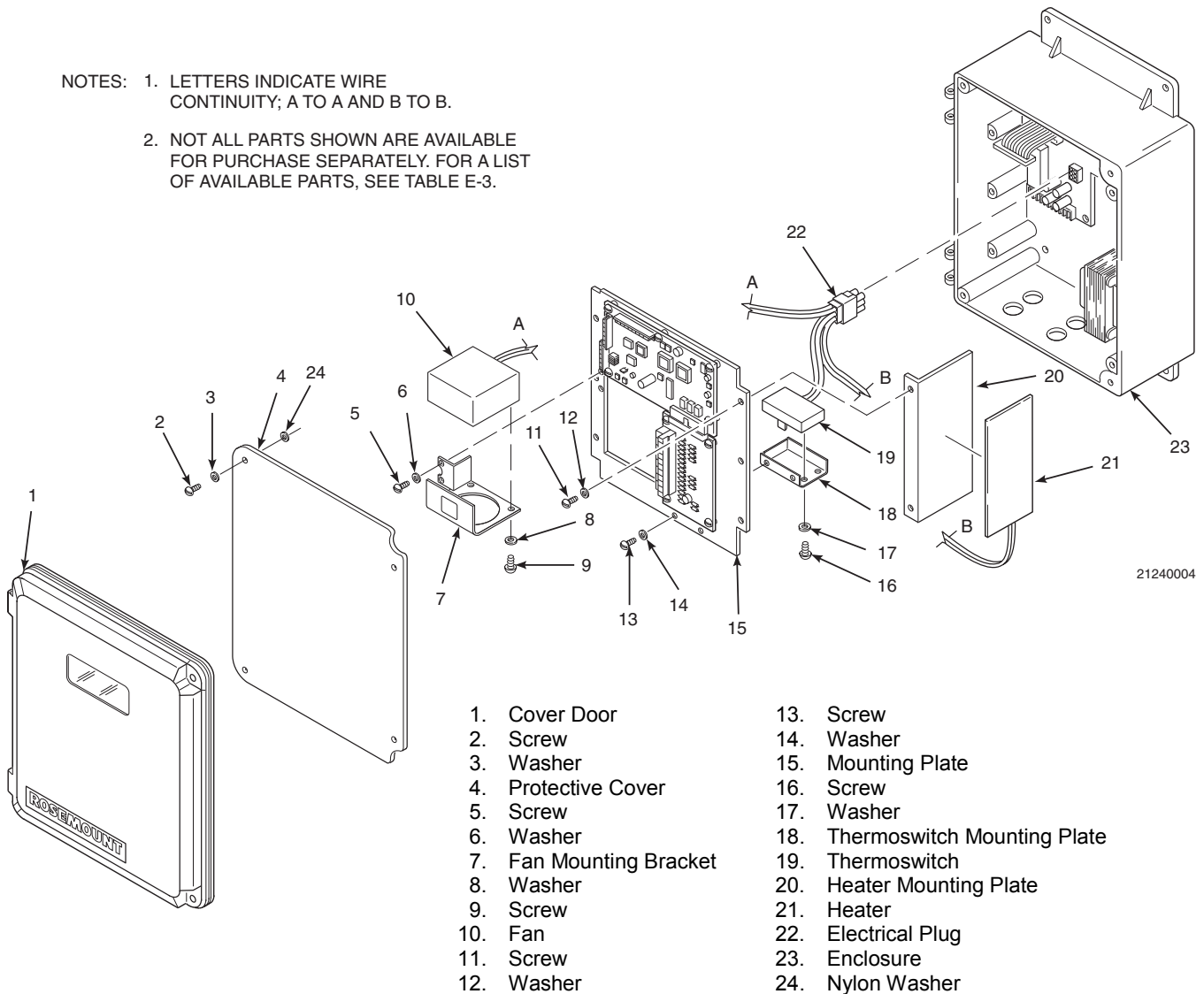

Figure E-8. IFT with Heater Option

REPLACEMENT PARTS

Table E-3. Replacement Parts for the Intelligent Field Transmitter.

FIGURE and INDEX No	PART NUMBER	DESCRIPTION
Figure E-6, 9	1N04946G01	Transformer
Figure E-6, 12	3D39120G01	Interconnect Board
Figure E-6, 4	3D39122G01*	Power Supply Board
Figure E-6, 11	3D39513G02	Microprocessor Board
Figure E-7, 3	1L04279H01	GUI Assembly
Figure E-6, 5	1L01293H02	Fuse, 5A @ 250 Vac, anti-surge, case size; 5 x 20 mm, type T to IEC127, Schurter
Figure E-8, 21	1A97964H01	Heater, 120V
Figure E-8, 21	1A97964H02	Heater, 240V
Figure E-8, 10	1M03255G01	Fan, 120V
Figure E-8, 10	1M03255G02	Fan, 240V
Figure E-8, 19	1M03256G01	Thermoswitch

*Specify line voltage and probe type when ordering.

APPENDIX J, REV 1.1 HART COMMUNICATOR MODEL 275D9E IFT 3000 APPLICATIONS

DESCRIPTION

J-1 COMPONENT CHECKLIST OF TYPICAL HART® COMMUNICATOR PACKAGE

A typical Model 275D9E HART® Communicator package should contain the items shown in Figure J-1, with the possible exception of options. If a rechargeable NiCad battery pack has been selected, at least one spare battery pack (per HART Communicator) is recommended.

J-2 UNIT OVERVIEW

a. Scope

This Instruction Bulletin supplies details needed to install and operate the HART® Communicator in relation to the World Class 3000 Intelligent Field Transmitter. Information on troubleshooting the communicator is also included.

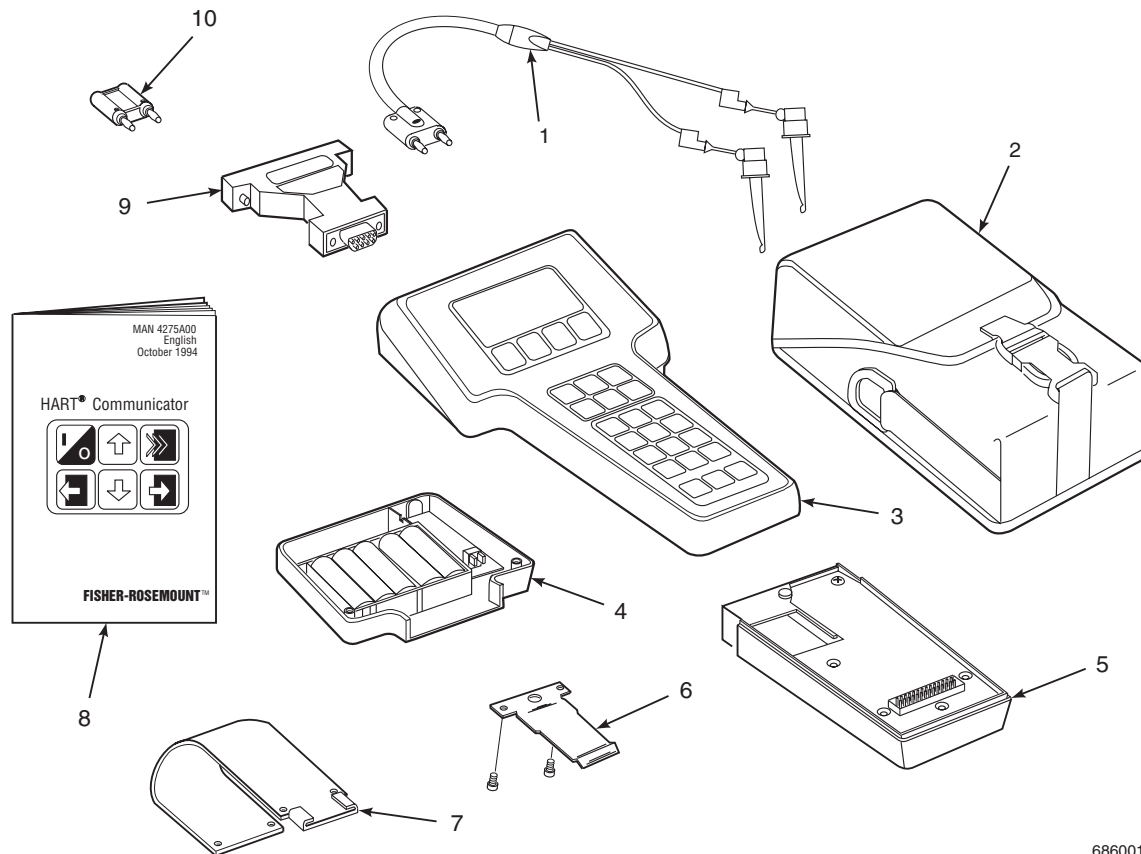

686001

- | | |
|--|--|
| <ol style="list-style-type: none"> 1. Lead Set (with Connectors) 2. Carrying Case 3. Communicator 4. AA Alkaline Battery Pack, or Rechargeable NiCad Battery Pack (Option) 5. Memory Module | <ol style="list-style-type: none"> 6. Belt Clip (with screws) 7. Hanger (mounts on belt clip, Option) 8. Pocket-sized Instruction Manual 9. PC Interface Adaptor (Option) 10. Load Resistor, 250 W (Option) |
|--|--|

Figure J-1. Typical HART® Communicator Package, Model 275D9E

b. Device Description

The HART (Highway Addressable Remote Transducer) Communicator is a hand-held communications interface device. It provides a common communications link to all microprocessor-based instruments which are HART compatible. The hand-held communicator contains an 8 x 21 character liquid crystal display and 25 keys. A pocket-sized manual, included with the HART Communicator, details the specific functions of all keys.

To interface with the IFT 3000, the HART Communicator requires a termination point along the 4-20 mA current loop, and a minimum load resistance of 250 ohms between the communicator and the power supply. The HART Communicator accomplishes its task by use of a frequency shift keying (FSK) technique. With the use of FSK, high-frequency digital communica-

tion signals are superimposed on the 4-20 mA transmitter current loop. The communicator does not disturb the 4-20 mA signal, since no net energy is added to the loop.

The HART Communicator may be interfaced with a personal computer, providing special software has been installed. To connect the HART Communicator to a PC, an interface adaptor is required. Refer to the proper HART Communicator documentation in regard to the PC interface option.

J-3 SPECIFICATIONS

HART Communicator Specifications, Table J-1, contains physical, functional, and environmental information about the communicator. Use Table J-1 to ensure the unit is operated in suitable environments, and that the proper battery charging options are used.

Table J-1. HART Communicator Specifications

Physical Specifications

Display	8-line liquid crystal display with a line width of 21 characters (128 x 64 pixels)
Keypad.....	Membrane design with tactile feedback. 25 keys include:
	6 action keys
	4 software-defined function keys
	12 alphanumeric keys
	3 shift keys
Weight.....	≈ 3 lbs (1.4 kg) including batteries

Functional Specifications

Memory.....	Nonvolatile memory. Retains memory when the communicator is not powered.
Program (and Device)	
Descriptions	1.25 MB
Transmitter Data	2 K
Power Supply.....	Five AA 1.5 volt batteries. A rechargeable Nickel-Cadmium battery pack is optional.
Battery Charger Options....	110/120 Vac, 50/60 Hz, U.S. plug
	220/230 Vac, 50 Hz, European plug
	220/230 Vac, 50 Hz, UK plug
Microprocessors	32-bit Motorola type 68331
	8-bit Motorola type 68HC05
Connections.....	Lead set: Two 4 mm banana plugs
	Battery charger: 2.5 mm jack
	Serial port: PC connection through optional adaptor
	Memory Module: 26 pin, 0.1 inch Berg connector

Environmental Specifications

Operating Limits.....	32° to 122°F (0° to 50°C)
Storage Limits.....	-4° to 158°F (-20° to 70°C)
Humidity.....	0 to 95% relative humidity under non-condensing conditions below 104°F (40°C) without error
Hazardous Locations	CENELEC - Intrinsic Safety Certification
Certifications	Factory Mutual (FM) - Intrinsic Safety Approval
	Canadian Standards Association (CSA) - Intrinsic Safety Approval

INSTALLATION

J-4 HART COMMUNICATOR SIGNAL LINE CONNECTIONS

The HART Communicator can connect to the IFT analog output signal line at any wiring termination point in the 4-20 mA current loop. There are two methods of connecting the HART Communicator to the signal line. For applications in which the signal line has a load resistance of 250 ohms or more, refer to method 1.

For applications in which the signal line load resistance is less than 250 ohms, refer to method 2.

a. Method 1, For Load Resistance > 250 Ohms

Refer to Figure J-2 and the following steps to connect the HART Communicator to a signal line with 250 ohms or more of load resistance.

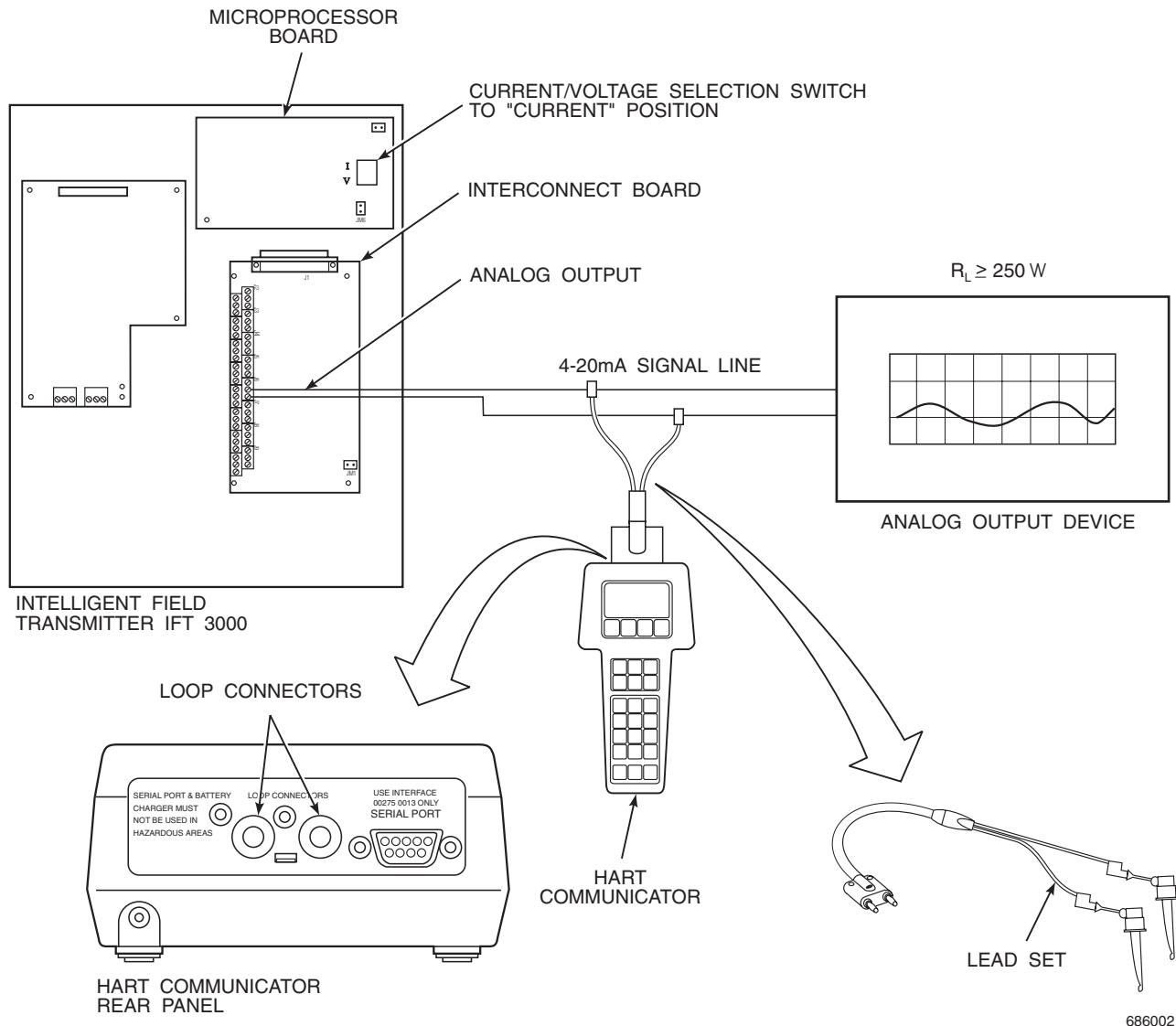

Figure J-2. Signal Line Connections, ≥ 250 Ohms Load Resistance

WARNING

Explosions can result in death or serious injury. Do not make connections to the HART Communicator's serial port or NiCad recharger jack in an explosive atmosphere.

1. Program IFT analog output to 4-20 mA. Select the current mode using the current/voltage selector switch on the microprocessor board in the IFT.
2. Using the supplied lead set, connect the HART Communicator in parallel to the IFT 3000. Use any wiring termination points in the analog output 4-20 mA signal line.

b. Method 2, For Load Resistance < 250 Ohms

Refer to Figure J-3 and the following steps to connect the HART Communicator to a signal line with less than 250 ohms load resistance.

WARNING

Explosions can result in death or serious injury. Do not make connections to the HART Communicator's serial port or NiCad recharger jack in an explosive atmosphere.

1. Program IFT analog output to 4-20 mA. Select the current mode using the current/voltage selector switch on the microprocessor board in the IFT.
2. At a convenient point, break the analog output 4-20 mA signal line and install the optional 250 ohm load resistor.
3. Plug the load resistor into the loop connectors (located on the rear panel of the HART Communicator).

J-5 HART COMMUNICATOR PC CONNECTIONS

There is an option to interface the HART Communicator with a personal computer. Load the designated Cornerstone[®] software into the PC. Then, link the HART Communicator to the PC using the interface PC adaptor which connects to the serial port (on the communicator rear panel).

Refer to the proper HART Communicator documentation in regard to the PC interface option.

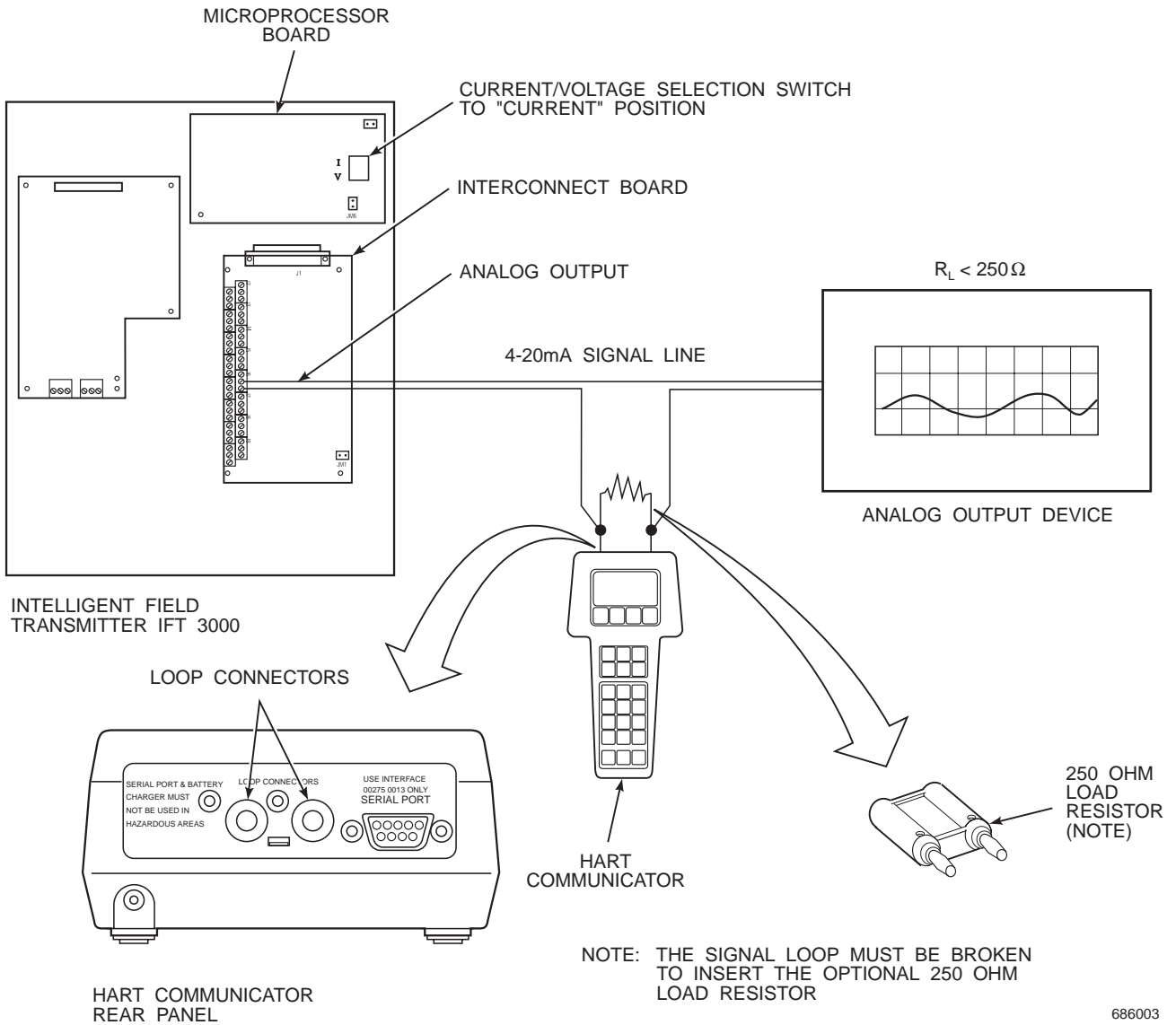

686003

Figure J-3. Signal Line Connections, < 250 Ohms Load Resistance

OPERATION

J-6 OFF-LINE AND ON-LINE OPERATIONS

The HART Communicator can be operated both off-line and on-line. Off-line operations are those in which the communicator is not connected to the IFT system. Off-line operations can include interfacing the HART Communicator with a PC (refer to applicable HART Documentation regarding HART/PC applications).

In the on-line mode, the communicator is connected to the 4-20 mA analog output signal line. The communicator is connected in parallel to the IFT, or in parallel to the 250 ohm load resistor.

The opening menu (displayed on the LCD) is different for on-line and off-line operations. When powering up a disconnected (off-line) communicator, the LCD will display the Main Menu. When powering up a connected (on-line) communicator, the LCD will display the On-line Menu. Refer to the HART Communicator manual for detailed menu information.

J-7 MENU TREE FOR HART COMMUNICATOR/ WORLD CLASS 3000 IFT APPLICATIONS

This section consists of a menu tree for the HART Communicator. This menu is specific to IFT 3000 applications.

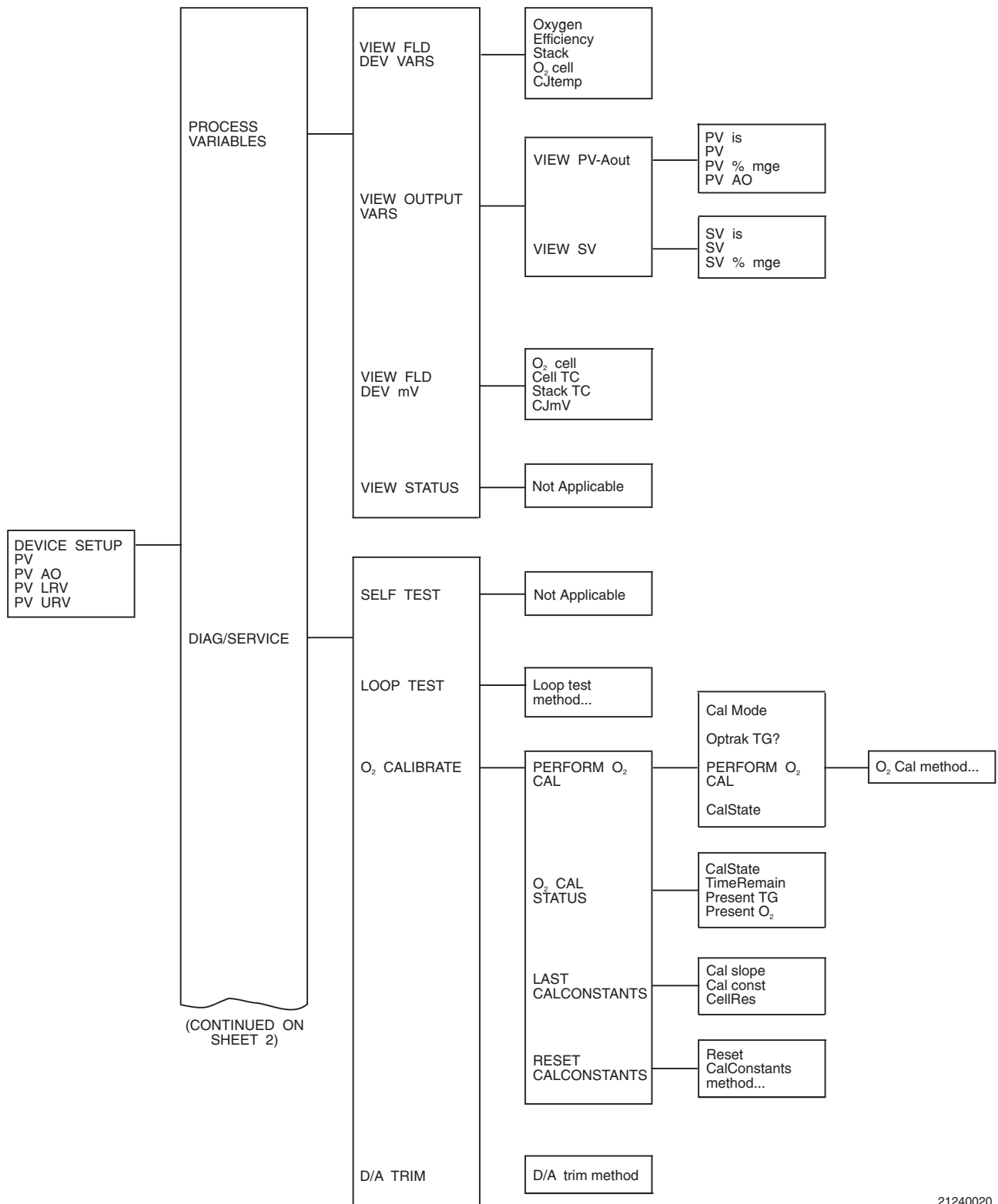

21240020

Figure J-4. Menu Tree for IFT 3000 Applications (Sheet 1 of 3)

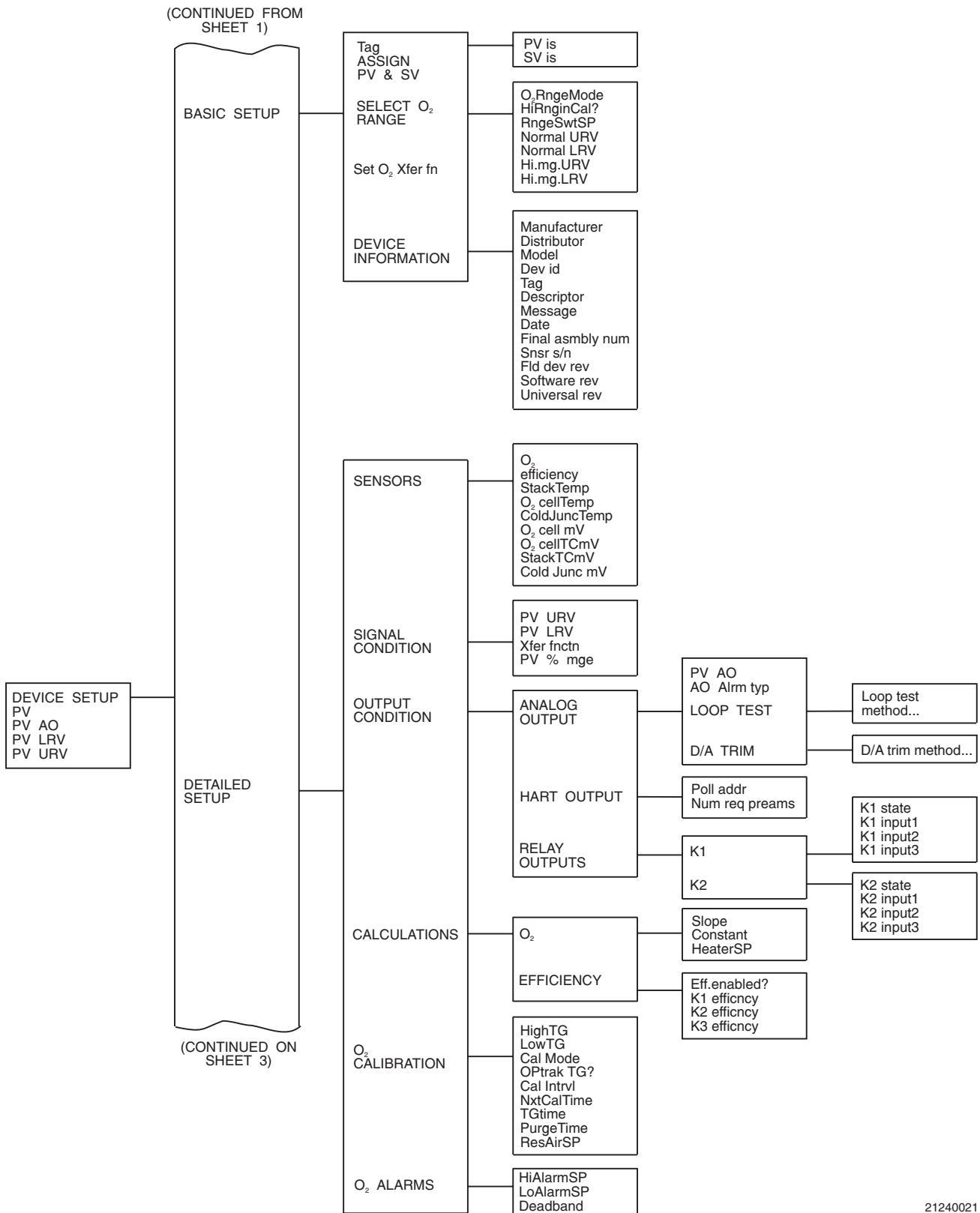

21240021

Figure J-4. Menu Tree for IFT 3000 Applications (Sheet 2 of 3)

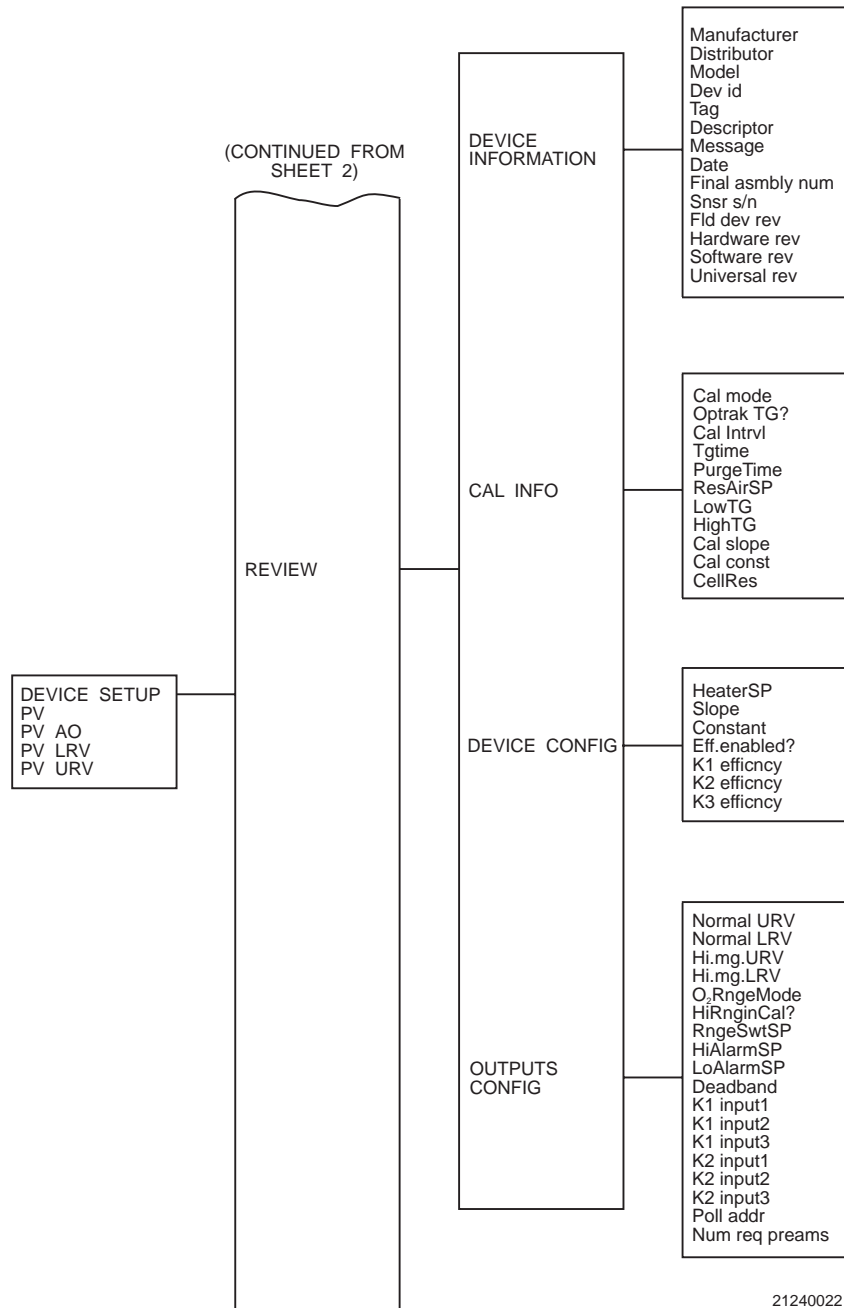

Figure J-4. Menu Tree for IFT 3000 Applications (Sheet 3 of 3)

TROUBLESHOOTING

J-8 OVERVIEW

If the HART Communicator fails to function properly, verify that the unit's battery pack and memory module are correctly assembled to the communicator. Check the communicator's model number. For IFT applications, HART Communicator model number 275D9E must be

used. If the HART Communicator model number is correct, and if it is properly assembled, the troubleshooting flowchart, Figure J-5, may be useful to find and correct problems.

J-9 TROUBLESHOOTING FLOWCHART.

Refer to Figure J-5.

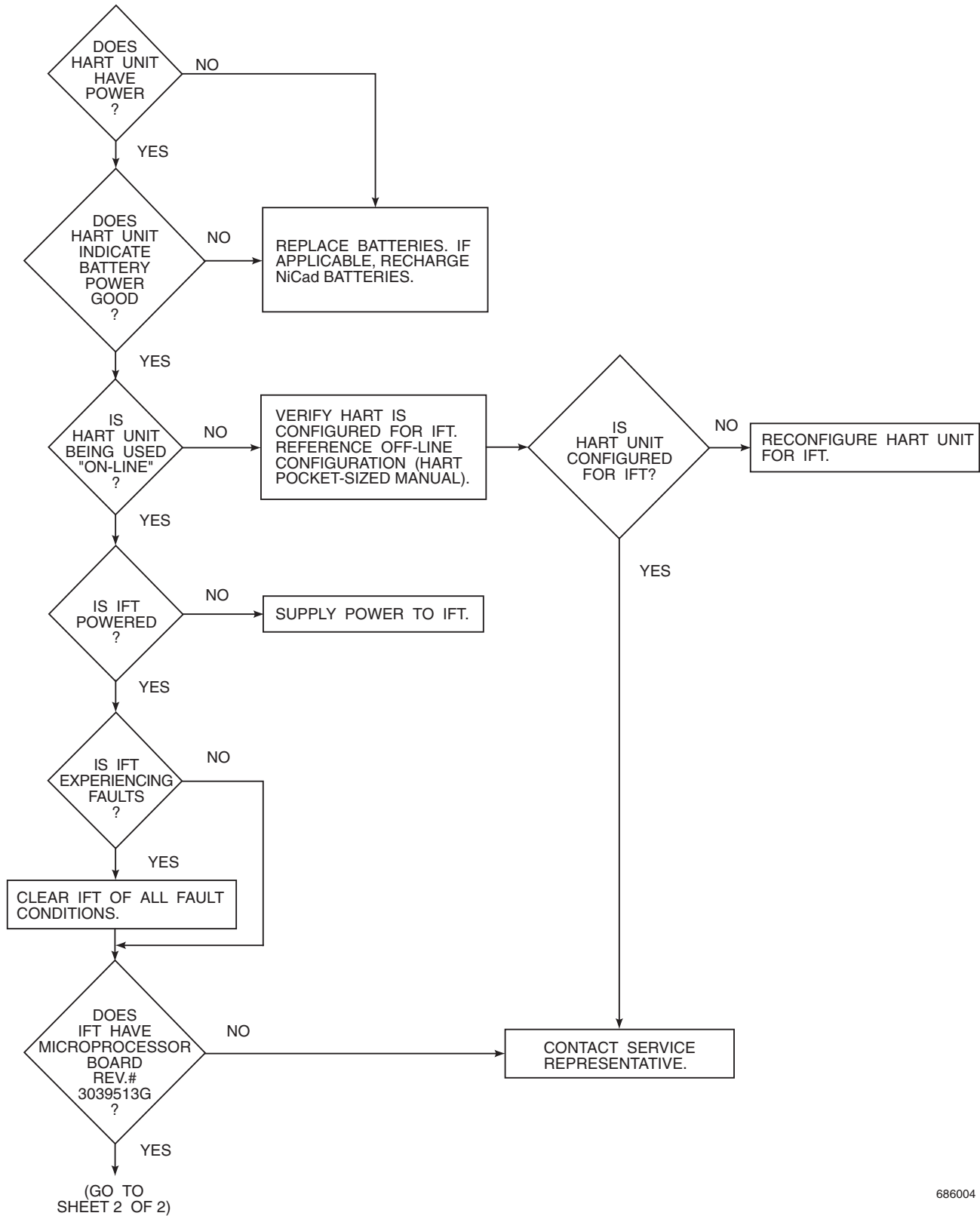

686004

Figure J-5. Model 275D9E, Troubleshooting Flowchart (Sheet 1 of 2)

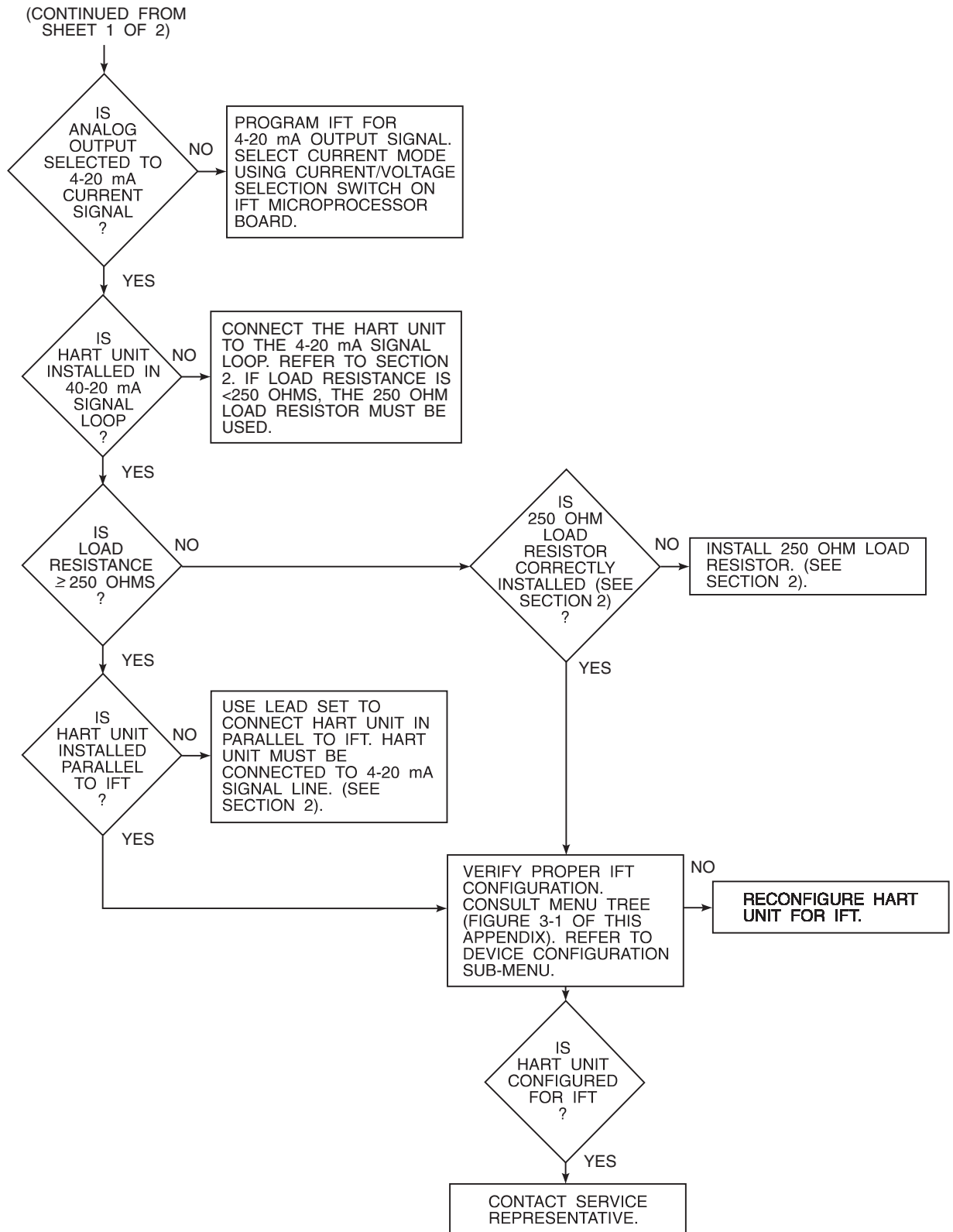

686005

Figure J-5. Model 275D9E, Troubleshooting Flowchart (Sheet 2 of 2)

RETURNING EQUIPMENT TO THE FACTORY

J-10 If factory repair of defective equipment is required, proceed as follows:

- a. Secure a return authorization number from a Rosemount Analytical Sales Office or Representative before returning the equipment. Equipment must be returned with complete identification in accordance with Rosemount instructions or it will not be accepted.

In no event will Rosemount be responsible for equipment without proper authorization and identification.

- b. Carefully pack defective unit in a sturdy box with sufficient shock absorbing material to insure that no additional damage will occur during shipping.
- c. In a cover letter, describe completely:
 - 1. The symptoms from which it was determined that the equipment is faulty.
 - 2. The environment in which the equipment has been operating (housing, weather, vibration, dust, etc.).
 - 3. Site from which equipment was removed.

- 4. Whether warranty service or non-warranty service is requested.

- 5. Complete shipping instructions for return of equipment.

- 6. Reference the return authorization number.

- d. Enclose a cover letter and purchase order and ship the defective equipment according to instructions provided in Rosemount Return Authorization, prepaid, to:

Rosemount Analytical Inc.
RMR Department
1201 N. Main Street
Orrville, Ohio 44667

If warranty service is requested, the defective unit will be carefully inspected and tested at the factory. If failure was due to conditions listed in the standard Rosemount warranty, the defective unit will be repaired or replaced at Rosemount's option, and an operating unit will be returned to the customer in accordance with shipping instructions furnished in the cover letter.

For equipment no longer under warranty, the equipment will be repaired at the factory and returned as directed by the purchase order and shipping instructions.

SECTION 9 INDEX

This index is an alphabetized listing of parts, terms, and procedures having to do with the Hazardous Area Oxygen/Combustibles Transmitter. Every item listed in this index refers to a location in the manual by one or more page numbers.

A

Abrasive Shield, 2-7
Absolute Temperature, 1-2
Adapter Plate, 1-1, 2-1
Air Pressure Regulator Valve, 2-22
Analog Output, 2-14, 5-13, 5-14
Annunciator, 2-14
Arithmetic Constant, 1-2
Automatic Calibration, 1-3, 2-23, 4-6, 5-10

B

Blind Version, 5-1

C

Cable Shields, 6-1
CAL, 5-2
CALIBRATE O₂ Sub-Menu, 5-4, 5-10
Calibration, 4-1
Calibration Constants, 4-1
Calibration Fittings, 1-7
Calibration Gas, 4-3
Calibration Gas Out, 2-23
Cell Constant, 1-2
Ceramic Diffusor, 2-1
Chart Recorders, 2-14
Check Valve, 1-7, 4-3

D

DATA, 5-2
Diagnostic Data, 5-3
Dust Seal Packings, 2-7

E

Electrical Noise, 6-1
Electrostatic Discharge, 6-1

G

Gas Kit, 4-5
Gas Mixture, 2-8, 4-2, 4-6
Gas Stratification, 2-1
General User Interface, 1-4, 5-1

Grounding, 6-1
GUI, 6-1

H

HART[®] Communications, 1-2, 5-1
HART[®] Communicator, 1-1
HART[®] Interface, 1-4
Heater Power Supply, 1-1, 1-3, 2-14, 2-20, 2-21
HELP, 5-2
High Gas, 2-22

I

Instrument Air, 1-7, 2-8
Instrument Air In, 2-22
Intelligent Field Transmitter, 1-1, 1-2, 5-1
Interconnect Board, 2-16

L

Languages, 1-3, 5-1
Low Gas, 2-23

M

MAIN Menu, 5-3
Manual Calibration, 4-2, 5-10
Microprocessor Board, 2-14
Mother Board, 2-21
MPS Wiring, 2-24
Multiprobe Calibration Gas Sequencer, 1-1, 1-2, 2-22

N

NEMA 4X Enclosure, 1-3, 2-9, 2-14

O

Orsat Apparatus, 1-2
Oxygen Analyzer, 1-1, 1-2, 1-3

P

Power Cable, 2-10, 2-17
Power Supply Board, 2-12
Pressure Regulator, 4-3, 4-4
PROBE DATA Sub-Menu, 5-3

Pushbutton Regulator, 4-5

Q

Quick Reference Chart, 5-3

R

Reference Air, 1-1, 2-8, 2-22

S

Semiautomatic Calibration, 2-23, 4-2, 4-6

SETUP Sub-Menu, 5-4

Status Line, 5-3

Stop Valve, 1-7

T

TGH, 5-2

TGL, 5-2

Troubleshooting, 6-1

V

Vee Deflector, 2-7

W

Wiring Layout, 2-13, 2-18, 2-19

Z

Zirconia Disc, 1-2

Z-purge, 1-7

ROSEMOUNT WARRANTY

Rosemount warrants that the equipment manufactured and sold by it will, upon shipment, be free of defects in workmanship or material. Should any failure to conform to this warranty become apparent during a period of one year after the date of shipment, Rosemount shall, upon prompt written notice from the purchaser, correct such nonconformity by repair or replacement, F.O.B. factory of the defective part or parts. Correction in the manner provided above shall constitute a fulfillment of all liabilities of Rosemount with respect to the quality of the equipment.

THE FOREGOING WARRANTY IS EXCLUSIVE AND IN LIEU OF ALL OTHER WARRANTIES OF QUALITY WHETHER WRITTEN, ORAL, OR IMPLIED (INCLUDING ANY WARRANTY OF MERCHANTABILITY OF FITNESS FOR PURPOSE).

The remedy(ies) provided above shall be purchaser's sole remedy(ies) for any failure of Rosemount to comply with the warranty provisions, whether claims by the purchaser are based in contract or in tort (including negligence).

Rosemount does not warrant equipment against normal deterioration due to environment. Factors such as corrosive gases and solid particulates can be detrimental and can create the need for repair or replacement as part of normal wear and tear during the warranty period.

Equipment supplied by Rosemount Analytical Inc. but not manufactured by it will be subject to the same warranty as is extended to Rosemount by the original manufacturer.

At the time of installation it is important that the required services are supplied to the system and that the electronic controller is set up at least to the point where it is controlling the sensor heater. This will ensure, that should there be a delay between installation and full commissioning that the sensor being supplied with ac power and reference air will not be subjected to component deterioration.

Instruction Manual

IB-106-300NH Rev. 4.2

July 2002

World Class 3000

<p style="text-align: center;">World Class 3000 Probe</p> <p>Part No. _____</p> <p>Serial No. _____</p> <p>Order No. _____</p>	<p style="text-align: center;">HPS 3000</p> <p>Part No. _____</p> <p>Serial No. _____</p> <p>Order No. _____</p>
<p style="text-align: center;">IFT 3000</p> <p>Part No. _____</p> <p>Serial No. _____</p> <p>Order No. _____</p>	<p style="text-align: center;">MPS 3000</p> <p>Part No. _____</p> <p>Serial No. _____</p> <p>Order No. _____</p>

Emerson Process Management

Rosemount Analytical Inc.
Process Analytic Division
1201 N. Main St.
Orrville, OH 44667-0901
T (330) 682-9010
F (330) 684-4434
E gas.csc@emersonprocess.com

Fisher-Rosemount GmbH & Co.
Industriestrasse 1
63594 Hasselroth
Germany
T 49-6055-884 0
F 49-6055-884209

ASIA - PACIFIC
Fisher-Rosemount
Singapore Private Ltd.
1 Pandan Crescent
Singapore 128461
Republic of Singapore
T 65-777-8211
F 65-777-0947

EUROPE, MIDDLE EAST, AFRICA
Fisher-Rosemount Ltd.
Heath Place
Bognor Regis
West Sussex PO22 9SH
England
T 44-1243-863121
F 44-1243-845354

LATIN AMERICA
Fisher - Rosemount
Av. das Americas
3333 sala 1004
Rio de Janeiro, RJ
Brazil 22631-003
T 55-21-2431-1882

<http://www.processanalytic.com>

