

Introduction

This Installation Guide provides instructions for installation, startup, and adjustment of 299H Series regulators. To receive a copy of the Instruction Manual, contact your local Sales Office or view a copy at www.fisherregulators.com. For further information refer to: 299H Series Instruction Manual, form 5497, D102684X012.

P.E.D. Categories

This product may be used as a safety accessory with pressure equipment in the following Pressure Equipment Directive 97/23/EC categories. It may also be used outside of the Pressure Equipment Directive using sound engineering practice (SEP) per table below.

PRODUCT SIZE	CATEGORY	FLUID TYPE
DN 40, 50 / NPS 1-1/2, 2	I	1

Specifications

Available Configurations

Type 299H: Pilot-operated pressure reducing regulator with a pilot integrally mounted to the actuator casing

Type 299HR: A Type 299H with a token internal relief valve to relieve minor overpressure caused by thermal expansion

Type 299HS: Same as the Type 299H with a Type VSX-2 slam-shut valve which provides overpressure or overpressure and underpressure protection

Type 299HSR: Same as the Type 299HS with an internal token relief valve

Body Size and End Connection Styles

See Table 1

Maximum Operating Inlet Pressure⁽¹⁾ by Orifice Size

- 6.4 x 9.5 mm / 1/4 x 3/8 inch – 12.1 bar / 175 psig
- 9.5 mm / 3/8 inch – 12.1 bar / 175 psig
- 13 mm / 1/2 inch – 12.1 bar / 175 psig
- 19 mm / 3/4 inch – 10.3 bar / 150 psig
- 22 mm / 7/8 inch⁽³⁾ – 8.6 bar / 125 psig
- 25 mm / 1 inch⁽³⁾ – 6.9 bar / 100 psig
- 30 mm / 1-3/16 inch⁽³⁾ – 5.5 bar / 80 psig

1. The pressure/temperature limits in this Installation Guide and any applicable standard or code limitation should not be exceeded.
2. For optimum performance, a pilot supply regulator may be installed in the pilot supply tubing between the main valve and pilot.
3. This orifice size is not available for Types 299HS and 299HSR.

Maximum Casing and Emergency Outlet Pressure⁽¹⁾

4.5 bar / 66 psig

Proof Test Pressure

All Pressure Retaining Components have been proof tested per Directive 97/23/EC - Annex 1, Section 7.4

Outlet (Control) Pressure Ranges⁽¹⁾⁽²⁾

See Table 2

Minimum Differential Pressure For Full Stroke

0.10 bar / 1.5 psi

Maximum Set Pressure for Type 299HS⁽¹⁾

1.1 bar / 16 psig

Maximum Set Pressure for Type VSX-2 Slam-Shut Device⁽¹⁾

1.6 bar / 23 psig

Minimum and Maximum Trip Pressure Ranges⁽¹⁾

See Table 3

Temperature Capabilities⁽¹⁾

-29 to 66°C / -20 to 150°F

Installation



WARNING

Only qualified personnel should install or service a regulator. Regulators should be installed, operated, and maintained in accordance with international and applicable codes and regulations, and Emerson Process Management Regulator Technologies Inc. (Regulator Technologies) instructions.

If the regulator vents fluid or a leak develops in the system, it indicates that service is required. Failure to take the regulator out of service immediately may create a hazardous condition.

Personal injury, equipment damage, or leakage due to escaping fluid or bursting of pressure-containing parts may result if this regulator is overpressured or is installed where service conditions could exceed the limits given in the Specifications section, or where conditions exceed any ratings of the adjacent piping or piping connections.

To avoid such injury or damage, provide pressure-relieving or pressure-limiting devices (as required by the appropriate code, regulation, or standard) to prevent service conditions from exceeding limits.

Additionally, physical damage to the regulator could result in personal injury and property damage due to escaping fluid. To avoid such injury and damage, install the regulator in a safe location.

Clean out all pipelines before installation of the regulator and check to be sure the regulator has not been damaged or has collected foreign material during shipping. For NPT bodies, apply pipe compound to the external pipe threads. For flanged bodies, use suitable line gaskets and approved piping and bolting practices. Install the regulator in any position desired, unless otherwise specified, but be sure flow through the body is in the direction indicated by the arrow on the body.

Note

It is important that the regulator be installed so that the vent hole in the spring case is unobstructed at all times. For outdoor installations, the regulator should be located away from vehicular traffic and positioned so that water, ice, and other foreign materials cannot enter the spring case through the vent. Avoid placing the regulator beneath eaves or downspouts, and be sure it is above the probable snow level.

Type VSX-2 Installation



If the Type VSX-2 is exposed to an overpressure condition, it should be inspected for any damage that may have occurred. Operation below these limits does not preclude the possibility of damage from external sources or from debris in the pipeline.

The Type VSX-2 may be shipped separately from the regulator. To install the unit on a regulator, place the new O-rings (keys 2 and 3, Figure 1) on the Type VSX-2 and slide the module into the regulator body. Secure the Type VSX-2 to the regulator body with the four set screws (key 4). The unit may be oriented in any direction with respect to the sensor line connection.

Overpressure Protection

The recommended pressure limitations are stamped on the regulator nameplate. Some type of overpressure protection is needed if the actual inlet pressure exceeds the maximum operating outlet pressure rating. Overpressure protection should also be provided if the regulator inlet pressure is greater than the safe working pressure of the downstream equipment.

Regulator operation below the maximum pressure limitations does not preclude the possibility of damage from external sources or debris in the line. The regulator should be inspected for damage after any overpressure condition.

Startup

The regulator is factory set at approximately the midpoint of the spring range or at the pressure requested, so an initial adjustment may be required to give the desired results. With proper installation completed and relief valves properly adjusted, slowly open the upstream and downstream shutoff valves.

Adjustment

To change the outlet pressure, remove the closing cap or loosen the locknut and turn the adjusting screw clockwise to increase outlet pressure or counterclockwise to decrease pressure. Monitor the outlet pressure with a test gauge during the adjustment. Replace the closing cap or tighten the locknut to maintain the desired setting.

Type VSX-2 Trip Adjustment

Note

An adjustment tool is included with the Type VSX-2. Use only this tool to make adjustments to the unit. To make adjustments, the overpressure trip spring is found under the outer adjusting screw and the underpressure trip spring is found under the inner adjusting screw.

To adjust the Overpressure Trip Spring:

1. Adjust the overpressure trip setting to its maximum compression.
2. If present, adjust the underpressure spring to its minimum compression.
3. Backpressure the unit with the desired overpressure trip pressure.
4. Reduce the overpressure trip spring compression until the Type VSX-2 trips.

Table 1. Body Sizes and End Connection Styles

BODY SIZE		BODY MATERIAL AND END CONNECTION STYLE		
DN	Inch	Cast Iron (For Types 299H and 299HR only)	Ductile Iron	Steel (For Types 299H and 299HR only)
32	1-1/4	NPT	----	----
40	1-1/2	NPT	NPT	NPT
50	2	NPT and CL125 FF ⁽¹⁾ flanged	NPT, CL125 FF, CL250 RF, and PN 10/16 flanged	NPT, CL150 RF, and PN 16 flanged

1. This flange is available with a face-to-face dimension of 191 mm / 7.5 inches or 254 mm / 10 inches.

Table 2. Outlet Pressure Ranges

OUTLET (CONTROL) PRESSURE RANGE		TYPE	
mbar	Inch w.c.	299H	299HR, 299HS, and 299HSR
9 to 15 ⁽¹⁾	3.5 to 6 ⁽¹⁾	X	X
12 to 22 ⁽¹⁾	5 to 9 ⁽¹⁾	X	X
17 to 50 ⁽¹⁾	7 to 20 ⁽¹⁾	X	X
40 to 99 ⁽¹⁾	16 to 40 ⁽¹⁾	X	X
69 mbar to 0.22 bar	1 to 3.25 psig	X	X
0.19 to 0.41 bar	2.75 to 6 psig	X	X
0.35 to 1.1 bar	5 to 16 psig	X	X
0.97 to 2.4 bar	14 to 35 psig	X	----
2.1 to 4.1 bar	30 to 60 psig	X	----

1. Use a pilot supply regulator if actual inlet pressure varies more than ± 1.4 bar / 20 psi and the published accuracy is required.

Table 3. Type VSX-2 High and Low Trip Pressure Ranges

SETPOINT RANGES	SLAM-SHUT TYPE	FOR USE WITH MAIN VALVE SPRING RANGE		MINIMUM TO MAXIMUM TRIP PRESSURE	
		mbar	Inch w.c.	mbar	Inch w.c.
High Pressure Trip	LP	9 to 15	3.5 to 6	30 to 62	12 to 25
		12 to 22	5 to 9		
		9 to 15	3.5 to 6	50 to 129	20 to 52
		12 to 22	5 to 9		
		17 to 50	7 to 20		
		17 to 50	7 to 20	97 to 269	1.4 to 3.9 psig
		40 to 99	16 to 40		
		40 to 99	16 to 40	262 to 600	3.8 to 8.7 psig
		69 mbar to 0.22 bar	1 to 3.25 psig		
		0.19 to 0.41 bar	2.75 to 6 psig		
		0.19 to 0.41 bar	2.75 to 6 psig	400 to 1103	5.8 to 16 psig
0.35 to 1.1 bar	5 to 16 psig				
0.35 to 1.1 bar	5 to 16 psig	800 to 1586	11.6 to 23 psig		
Low Pressure Trip	LP	12 to 22	5 to 9	5 to 30	2 to 12
		17 to 50	7 to 20		
		17 to 50	7 to 20	10 to 75	4 to 30
		40 to 99	16 to 40		
		69 mbar to 0.22 bar	1 to 3.25 psig	25 to 159	0.36 to 2.3 psig
		0.19 to 0.41 bar	2.75 to 6 psig		
		0.19 to 0.41 bar	2.75 to 6 psig	103 to 745	1.5 to 10.8 psig
0.35 to 1.1 bar	5 to 16 psig				

Note: Other spring combinations are available, please contact your local Sales Office for additional information.

299H Series

To adjust the Underpressure Trip Spring:

1. Adjust the underpressure trip spring back to its minimum compression.
2. Backpressure the unit with the desired underpressure trip pressure.
3. Increase the underpressure trip spring compression until the Type VSX-2 trips.

Taking Out of Service (Shutdown)



WARNING

To avoid personal injury resulting from sudden release of pressure, isolate the regulator from all pressure before attempting disassembly.

The seal and warning tag contain important safety information, if removed be sure to reattach before startup.

Parts List

Type VSX-2 Slam-Shut Device (Figure 1)

Key	Description
1	Type VSX-2 Module
2*	Upper O-ring
3*	Lower O-ring
4	Set Screw
6	Type Y602-12 Vent Assembly
7	High-Pressure Control Spring
8	Low-Pressure Control Spring
10	Machine Screw
11*	Gasket
12	Adjustment Tool
13	Pipe Plug

P590 Series Filter (Figure 2)

Key	Description
1	Filter Body
2*	Filter Element
3	Filter Head
4	Machine Screw
5	Washer
6	Spring Washer
7*	Gasket

299H Series Regulator (Figures 3 through 6)

Key	Description
1	Lower Casing
2	Upper Casing
3	Closing Cap
4	Spring Seat

299H Series Regulator (Figures 3 through 6) (continued)

Key	Description
5	Adjustment Nut
6	Closing Spring
7	Pressure Equalization Spring
8*	Diaphragm
9*	O-ring
10	Diaphragm Post
11	Pusher Post
12	Orifice
13*	Disk
14*	O-ring
15*	O-ring
16	Valve Stem Assembly
17	Valve Body
18	Cap Screw
19	Elbow
20	Connector
21	Pilot Supply Tubing (Without Filter)
22	Loading Tubing
23	Cap Screw
24	Machine Screw
25	Lever Pin
26	Lever
27	Vent Hood (Type Y602-12 Vent Assembly)
28	Diaphragm Assembly
29	Closing Cap
30	Machine Screw
31	Spring Case
32	Control Spring
33	Spring Seat
34	Bonnet
35	Locknut
36	Adjusting Screw
37	Hex Nut
38	Washer
39	Diaphragm Post
40	Pusher Post
41	Overtravel Spring
42	Machine Screw
43	Rivet
44	Retaining Ring
45	Check Valve Assembly
46	Machine Screw
47	Inlet Fitting
48	Stem Assembly
49*	O-ring
50	Pilot Orifice
51	Inlet Screen
52*	Pilot Disk Assembly
53*	O-ring
54*	O-ring
56	Screw
57	Lever
58	Pipe Plug
59	Pipe Plug, Internal Registration only
61	O-ring
62	Drive Screw
63	Nameplate
68*	Wire Seal
69	Warning Tag, Aluminum
70	Bleed Restriction
80	Pad
81	Diaphragm Head
82	Insert (For Types 299HS and 299HSR only, see Figure 1)
83	O-ring (For Types 299HS and 299HSR only, see Figure 1)
84	Plate (For Types 299H and 299HR only)
85	O-ring (For Types 299H and 299HR only)
86	O-ring (For Types 299H and 299HR only)
87	Set Screw (For Types 299H and 299HR only)
88	Spring Seat (For Types 299HR and 299HSR only)
89	Label
93	Spring Seat Washer

*Recommended spare part

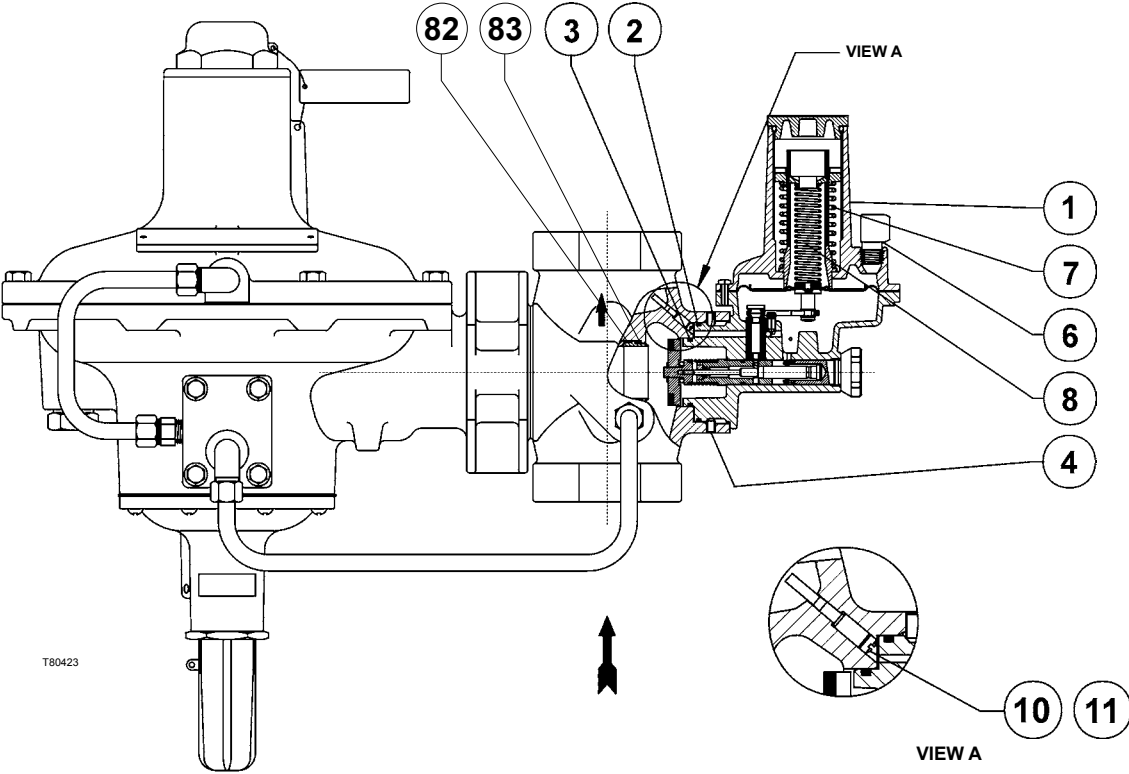

NOTE: FOR KEYS 82 AND 83, REFER TO 299H SERIES REGULATORS PARTS LIST.

Figure 1. Type VSX-2 Assembly

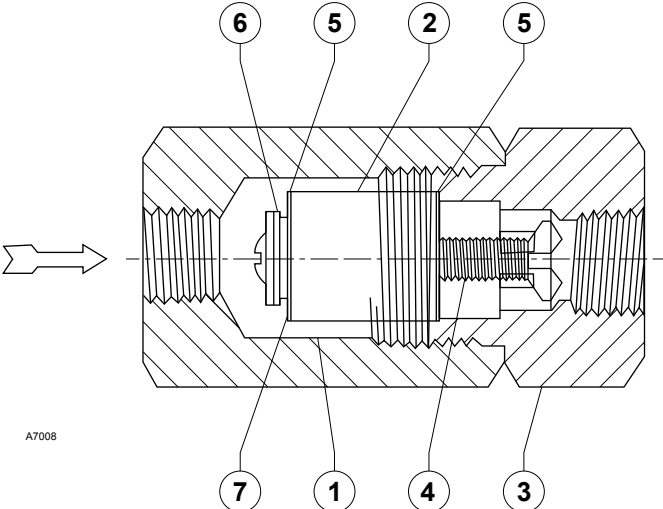
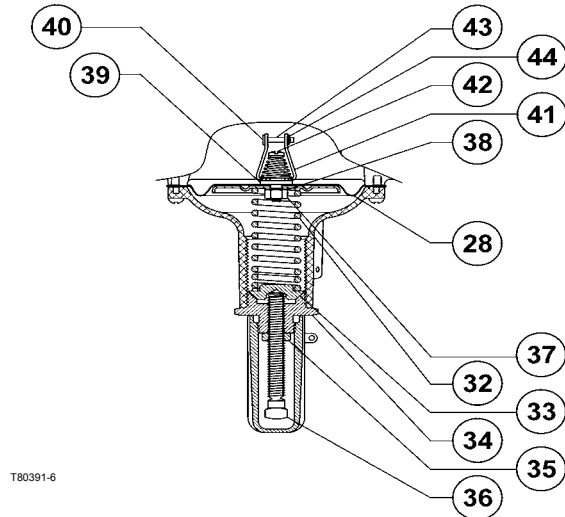

Figure 2. Optional P590 Series Filter

299H Series



T80391-6

TYPE 299H PILOT WITHOUT RELIEF VALVE

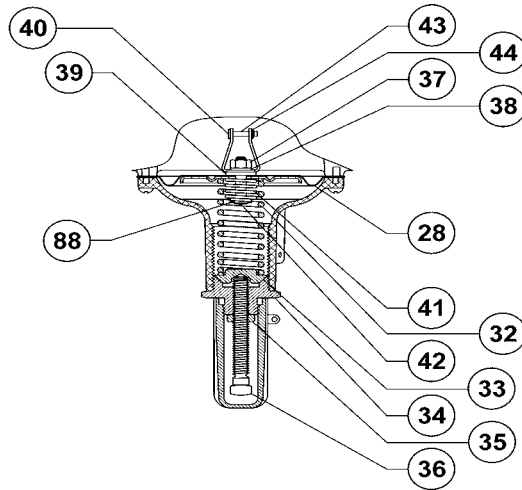

T80391-6

TYPE 299HR PILOT WITH TOKEN RELIEF VALVE

Figure 3. 299H Series Pilot Assemblies

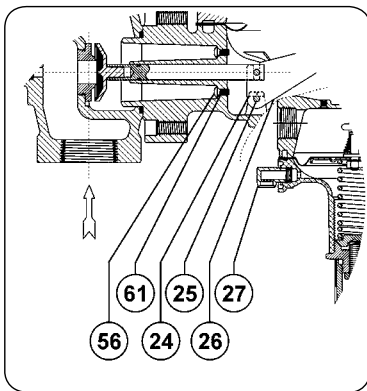

T80391-2

EXTERNAL REGISTRATION

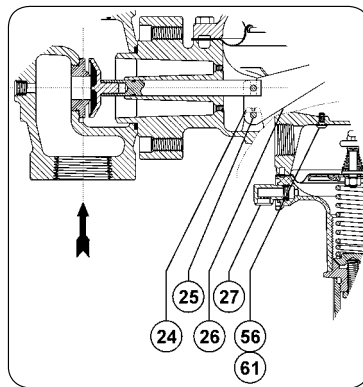

T80391-4

DUAL REGISTRATION

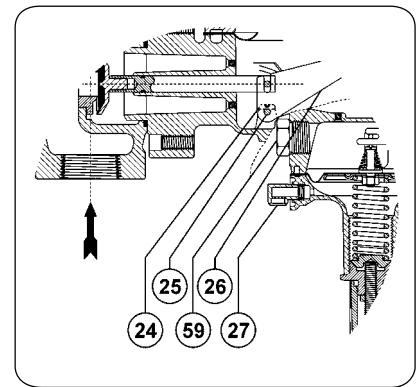

T80391-3

INTERNAL REGISTRATION

Figure 4. 299H Series Registration Assemblies

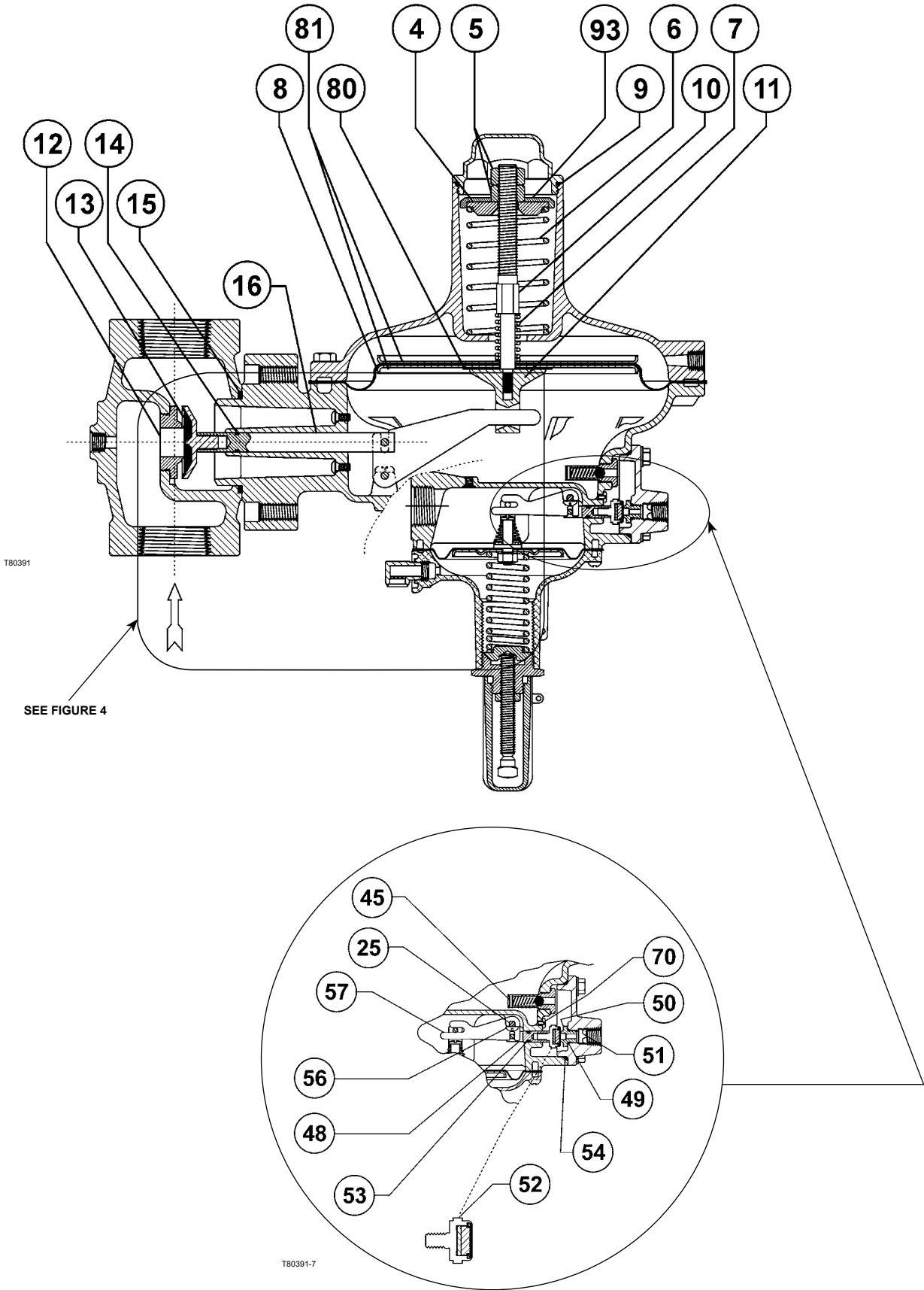

299H SERIES PILOT TRIM

Figure 5. 299H Series Interior Assembly

299H Series

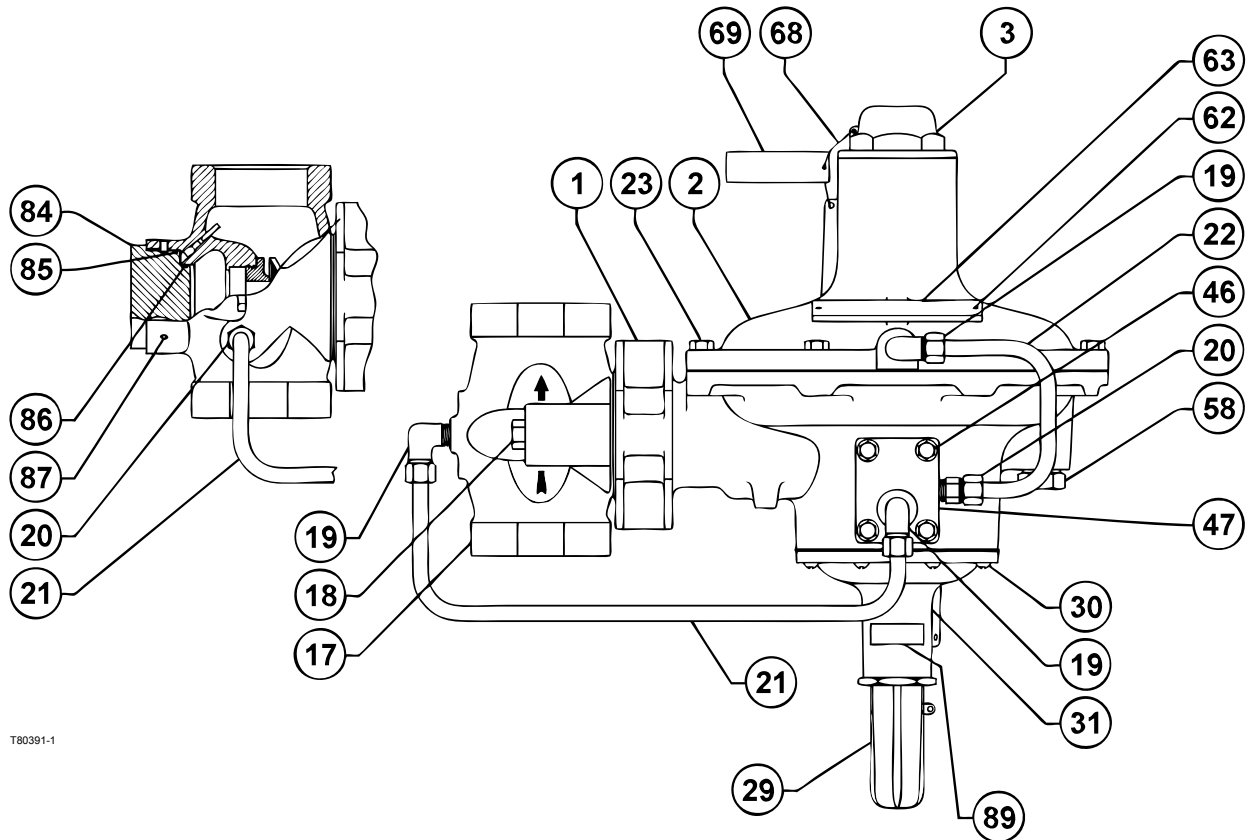

T80391-1

Figure 6. 299H Series Exterior Assembly

Industrial Regulators

Emerson Process Management Regulator Technologies, Inc.

USA - Headquarters
McKinney, Texas 75069-1872, USA
Tel: +1 800 558 5853
Outside U.S. +1 972 548 3574

Asia-Pacific
Shanghai 201206, China
Tel: +86 21 2892 9000

Europe
Bologna 40013, Italy
Tel: +39 051 419 0611

Middle East and Africa
Dubai, United Arab Emirates
Tel: +971 4811 8100

Natural Gas Technologies

Emerson Process Management Regulator Technologies, Inc.

USA - Headquarters
McKinney, Texas 75069-1872, USA
Tel: +1 800 558 5853
Outside U.S. +1 972 548 3574

Asia-Pacific
Singapore 128461, Singapore
Tel: +65 6770 8337

Europe
Bologna 40013, Italy
Tel: +39 051 419 0611
Chartres 28008, France
Tel: +33 2 37 33 47 00

TESCOM

Emerson Process Management Tescom Corporation

USA - Headquarters
Elk River, Minnesota 55330-2445, USA
Tels: +1 763 241 3238
+1 800 447 1250

Europe
Selmsdorf 23923, Germany
Tel: +49 38823 31 287

Asia-Pacific
Shanghai 201206, China
Tel: +86 21 2892 9499

For further information visit www.emersonprocess.com/regulators

The Emerson logo is a trademark and service mark of Emerson Electric Co. All other marks are the property of their prospective owners. Fisher is a mark owned by Fisher Controls International LLC, a business of Emerson Process Management.

The contents of this publication are presented for informational purposes only, and while every effort has been made to ensure their accuracy, they are not to be construed as warranties or guarantees, express or implied, regarding the products or services described herein or their use or applicability. We reserve the right to modify or improve the designs or specifications of such products at any time without notice.

Emerson Process Management Regulator Technologies, Inc. does not assume responsibility for the selection, use or maintenance of any product. Responsibility for proper selection, use and maintenance of any Emerson Process Management Regulator Technologies, Inc. product remains solely with the purchaser.