

TUpH™ pH/ORP Sensors

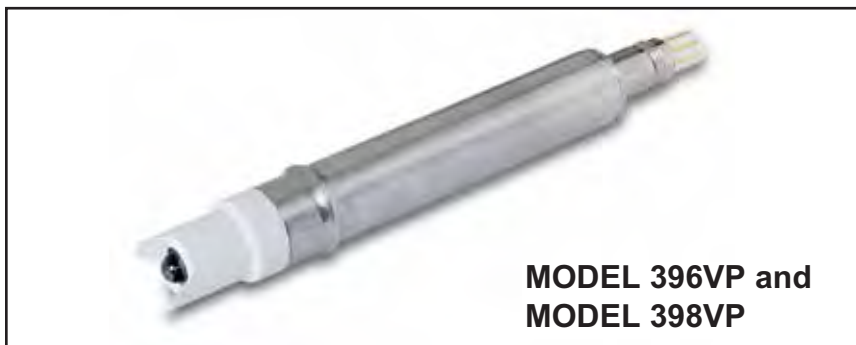
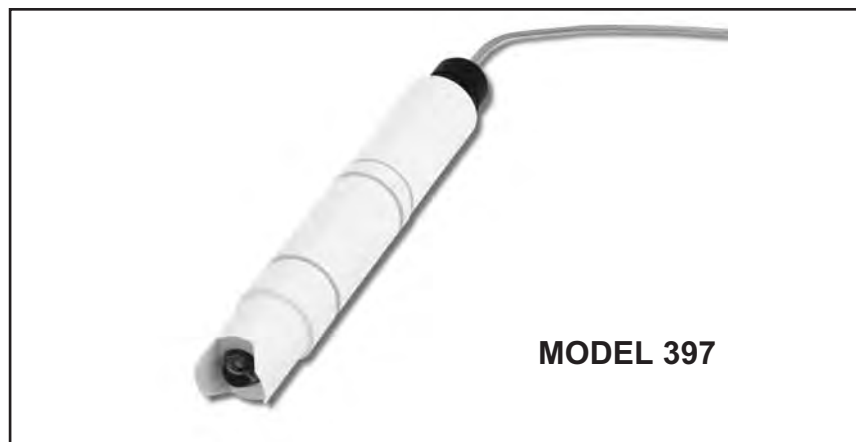

ESSENTIAL INSTRUCTIONS

READ THIS PAGE BEFORE PROCEEDING!

Rosemount Analytical designs, manufactures, and tests its products to meet many national and international standards. Because these instruments are sophisticated technical products, you must properly install, use, and maintain them to ensure they continue to operate within their normal specifications. The following instructions must be adhered to and integrated into your safety program when installing, using, and maintaining Rosemount Analytical products. Failure to follow the proper instructions may cause any one of the following situations to occur: Loss of life; personal injury; property damage; damage to this instrument; and warranty invalidation.

- Read all instructions prior to installing, operating, and servicing the product. If this Instruction Manual is not the correct manual, telephone 1-800-654-7768 and the requested manual will be provided. Save this Instruction Manual for future reference.
- If you do not understand any of the instructions, contact your Rosemount representative for clarification.
- Follow all warnings, cautions, and instructions marked on and supplied with the product.
- Inform and educate your personnel in the proper installation, operation, and maintenance of the product.
- Install your equipment as specified in the Installation Instructions of the appropriate Instruction Manual and per applicable local and national codes. Connect all products to the proper electrical and pressure sources.
- To ensure proper performance, use qualified personnel to install, operate, update, program, and maintain the product.
- When replacement parts are required, ensure that qualified people use replacement parts specified by Rosemount. Unauthorized parts and procedures can affect the product's performance and place the safe operation of your process at risk. Look alike substitutions may result in fire, electrical hazards, or improper operation.

DANGER

HAZARDOUS AREA INSTALLATION

This sensor is not Intrinsically Safe. or Explosion Proof. Installations near flammable liquids or in hazardous area locations must be carefully evaluated by qualified on site safety personnel.

To secure and maintain an intrinsically safe installation, an appropriate transmitter/safety barrier/sensor combination must be used. The installation system must be in accordance with the governing approval agency (FM, CSA or BASEEFA/CENELEC) hazardous area classification requirements. Consult your analyzer/transmitter instruction manual for details.

Proper installation, operation and servicing of this sensor in a Hazardous Area Installation is entirely the responsibility of the user.

CAUTION

SENSOR/PROCESS APPLICATION COMPATIBILITY

The wetted sensor materials may not be compatible with process composition and operating conditions. Application compatibility is entirely the responsibility of the user.

About This Document

This manual contains instructions for installation and operation of the Models 396, 396VP, 397, 398, and 398VP TUpH pH/ORP Sensors. The following list provides notes concerning all revisions of this document.

<u>Rev. Level</u>	<u>Date</u>	<u>Notes</u>
0	3/99	This is the initial release of the product manual. The manual has been reformatted to reflect the Emerson documentation style and updated to reflect any changes in the product offering.
A	12/01	Revised wiring diagram on page 24.
B	2/02	Added info to page 1.
C	6/02	Updated multiple drawings.
D	8/02	Added drawing #40105549, rev. D.
E	10/02	Revised drawing #40039601, rev. J, on page 10.
F	4/03	Revised Model 397 specs on page 2, and revised drawing on page 27.
G	8/03	Added Silcore information.
H	3/04	Added Xmt wiring drawings.
I	10/04	Added 5081 wiring drawing and updated 1055 wiring.
J	2/06	Changed drawing 40039603 rev. C, on page 13. Added a note on page 15.
K	1/07	Miscellaneous revisions
L	11/10	Removed mention of patents and updated dnv logo

TUpH MODELS 396/396VP/397/398/398VP pH/ORP SENSORS

TABLE OF CONTENTS

Section	Title	Page
1.0	DESCRIPTION AND SPECIFICATIONS	1
1.1	TUpH™ Features and Applications	1
1.2	Performance and Physical Specifications	3
1.3	Ordering Information	4
2.0	INSTALLATION	9
2.1	Unpacking and Inspection	9
2.2	Mounting	9
2.3	Electrical Installation	15
3.0	START UP AND CALIBRATION	31
3.1	Sensor Preparation	31
3.2	Calibration Using Buffer Solutions or Grab Samples	31
4.0	MAINTENANCE	32
4.1	Electrode Cleaning	32
4.2	Automatic Temperature Compensator	32
5.0	TROUBLESHOOTING	33
6.0	RETURN OF MATERIAL	34

LIST OF TABLES

Number	Title	Page
4-1	R ₀ and R ₁ Values for Temperature Compensation Elements	22
4-2	Temperature vs Resistance of Auto T.C. Elements	22
5-1	Troubleshooting	23

LIST OF FIGURES

Number	Title	Page
1-1	Cross Section Diagram of the TUpH Reference Technology.....	2
2-1	Flow Through/Insertion Installation for Models 396, 396VP, 398, & 398VP	10
2-2	Dimensional Drawing For Models 396 & 398.....	11
2-3	Dimensional Drawing For Models 396VP & 398VP	12
2-4	Submersion Installations For Models 396, 396VP, 398, & 398VP	13
2-5	Dimensional Drawings For Model 397 in the Quik-Loc Unit.....	14
2-6	Recommended Flow Through and Insertion Installation For Model 397	15
2-7	Models 396/397/398 Standard Wiring option used with Models 1054A,	15
	1054B, 2054, and Preamps PN 22698-02 & 22698-03	
2-8	Models 396/397/398 Option -62 for wiring to Models 1054, 1181, 2081, 54,	15
	81, 3081, 4081, SoluComp, and 2700 Preamp (PN 23054-03) and remote	
	J-box PN 23555-00.....	
2-9	Wiring Models 396-54 (50), 397-54 (50), & 398-54 (50) to J-Box	16
	(PN 23309-04 (03)) & Remote Preamplifier	
2-10	Wiring Models 396-54, 397-54, & 398-54 (PT-100-RTD) to J-Box (PN 23555-00)	17
	& Remote Preamplifier	
2-11	Wiring Models 396/397/398 to Model 1181pH.....	18
2-12	Wiring Models 396-54, 397-54, & 398-54 to Models 1054A pH, 1054B pH,	19
	& 2054pH-54	
2-13	Wiring Models 396-54, 397-54, & 398-54 to Models 2081pH-05 & 1054pH-54	20
2-14	Wiring Models 396-54, 397-54, & 398-54 to Models 54, 81, 3081, & 4081.....	21
2-15	Wiring Models 396-54, 397-54, & 398-54 to SoluComp Model SCL-P-014	22
2-16	Wiring Models 396-54, 397-54, & 398-54 to Model 2700 Preamp	23
2-17	Wiring Models 396-()-54-62-(71), 397-02-10-54-62, & 398-()-54-62 to	23
	Model 1055-01-10-22-32	
2-18	Wiring Models 396-54-62, 397-02-54-62, & 398-54-62 to Model 1055-22-32.....	23
2-19	Wire Functions and Pin Connections for Variopol Connector Cable	24
2-20	Wiring Models 396VP/398VP to Model 81 thru a remote J-box	24
2-21	Wiring Models 396VP/398VP to Model 81	24
2-22	Wiring Models 396VP/398VP to Model 1181.....	24
2-23	Wiring Models 396VP/398VP to Model 1181, 1050/1060, 1003/1023 thru a	25
	remote J-box.....	
2-24	Wiring Models 396VP/398VP to Model 2081	25
2-25	Wiring Models 396VP/398VP to Model 3081 & 4081	25
2-26	Wiring Models 396VP/398VP to Model 2081 thru a remote J-box	25
2-27	Wiring Models 396VP/398VP to Model 3081 & 4081 thru a remote J-box.....	25
2-28	Wiring Models 396VP/398VP to Model 1054	26
2-29	Wiring Models 396VP/398VP to Model 1054A/B & 2054	26
2-30	Wiring Models 396VP/398VP to Model 1054 thru a remote J-box	26
2-31	Wiring Models 396VP/398VP to Model 1054A/B & 2054 thru a remote J-box.....	26
2-32	Wiring Models 396VP/398VP to Model 54/54e thru a remote J-box	27
2-33	Wiring Models 396VP/398VP to Model 54/54e	27
2-34	Wiring Models 396VP/398VP to Model SCL-(P/Q).....	27
2-35	Wiring Models 396VP/398VP to Model 2700	27
2-36	Wiring Models 396VP/398VP to Model 1055-22-32.....	28
2-37	Wiring Models 396/397/398 to Model Xmt.....	29
2-38	Wiring Models 396VP/398VP to Model Xmt.....	29
2-39	Wiring Models 396/397/398 to Model 5081-P	30
2-40	Wiring Models 396-54-62/398-54-62 to Model 1055-01-10-22-32	30

SECTION 1.0

DESCRIPTION AND SPECIFICATIONS

1.1 TUpH™ FEATURES AND APPLICATIONS.

Rosemount Analytical has achieved a new industry standard for the life expectancy of pH sensors with the TUpH Sensors. The low maintenance, disposable Models 396, 396VP, 397, 398, and 398VP TUpH Sensors offer long life and high performance in the measurement of pH in aqueous solutions in pipelines, open tanks, or ponds. These TUpH sensors feature a large area reference junction for maximum resistance to process coatings, generally found in dirty, high solid applications. In addition, the secondary helical reference pathway serves as added protection from poisoning ions. The simplified construction, designed with user convenience in mind, does not require electrolyte replenishment or any component replacement. All models feature a large glass bulb for increased resistance to the effects of aging for longer life. All models are available only without an integral preamplifier. The preamplifier must be in a remote location or integral to the analyzer/transmitter. Models with a "VP" after the model number indicate the variopole connector is used on the sensor in place of the cable. In this case, a separate cable with a mating VP connector must be used. All models are compatible with all Rosemount Analytical and most manufacturers instruments.

The entire line of TUpH model sensors now incorporate the new SILCORE technology contaminant barrier. This triple-seal barrier prevents moisture and material impurities from migrating to the pH sensor's reference electrode's metal lead wire. By preventing these contaminants from compromising the integrity of the pH measurement, sensor life is increased, especially at higher temperatures where increased migrations occur. In addition, the SILCORE¹ technology provides added protection against sensor failure due to vibrations and shock by transferring damaging energy away from the glass-to-metal seal.

1.1.1 Model 396 and 396VP TUpH Features and Applications.

The Models 396 and 396VP TUpH sensors are constructed of polypropylene and stainless steel and is completely sealed by EP (ethylene propylene) to eliminate process intrusion. It is specifically designed for improved life in harsh, dirty applications such as lime slurry waste treatment and paper machine headbox and pigment/dye applications where large quantities of suspended solids are present. Installation is easily achieved through a wide variety of



mounting configurations. The Model 396 features an optional front or rear 1 in. MNPT process connection for insertion, submersion, or flow through applications.

1.1.2 Model 397 TUpH and Quik-Loc Features and Applications.

The Model 397 is housed in a highly chemical resistant polypropylene body and completely sealed with EP to eliminate process intrusion. The Model 397 body is specifically designed for use with the Quik-Loc Kit which consists of an adapter and coupler. The PEEK (polyetheretherketone) adapter enables the Model 397 sensor to fit into a 1 in. MNPT Dixon coupler for quick and easy removal without sensor cable twisting. The 316 stainless steel Dixon coupler is sealed with EP and features locking arms. The Quik-Loc Kit is not recommended for use in processes with hazardous, corrosive, or strong oxidizing chemicals due to a risk of spray and bodily hazards.



1.1.3 Model 398 and 398VP TUpH Features and Applications.

The chemical-resistant construction of Tefzel, titanium, and the TUpH reference junction make the Models 398 and 398VP the ideal sensors for measuring pH in harsh process liquids. Use Model 398 or 398VP to measure pH in sour water strippers, in pulp bleaching towers that use chlorine dioxide, and in process streams containing a variety of organic solvents.



Models 398 and 398VP use the highest quality materials to provide superior chemical resistance. The sensors are housed in a titanium tube and features an optional 1 inch MNPT process connector for insertion, submersion, or flow-through applications. The molded Tefzel TUpH construction is offered with a choice of seals (Viton, EPDM, or Kalrez). Combining high quality materials with the TUpH reference technology and ACCUGLASS¹ pH bulb allows for ultimate chemical resistance and makes Models 398 and 398VP the perfect choice for measuring pH in harsh, demanding processes.

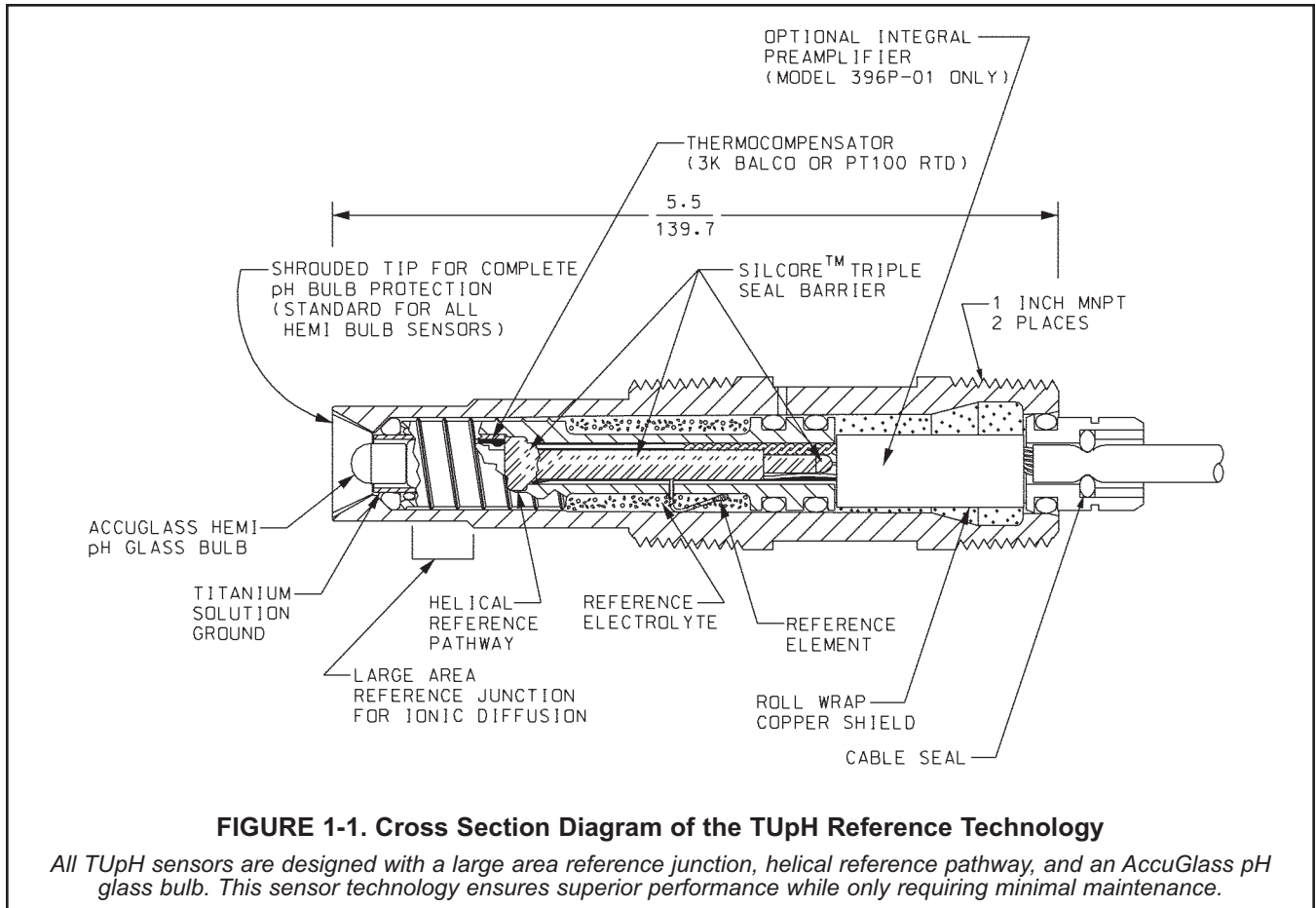

¹ ACCUGLASS and Silcore are trademarks of Rosemount Analytical



1.2 PERFORMANCE & PHYSICAL SPECIFICATIONS

SPECIFICATIONS				
	MODELS 396 & 396VP	MODELS 398 & 398VP	MODEL 397	QUIK-LOC KIT
Measurements and Ranges	pH: 0-14	pH: 0-14 ORP: -1500 to 1500 mv	pH: 0-14	—
Available pH AccuGLASS Types	GPHT hemi bulb or GPLR flat bulb	GPHT hemi bulb or GPLR flat bulb	GPHT hemi bulb	—
Wetted Materials	316 SST, Polypropylene, EPDM, glass	Titanium, Tefzel, glass, choice of Kalrez, Viton, or EPDM (platinum: ORP only)	Polypropylene, EP, glass	316 SST, EP, PEEK
Process Connection	None, use 1 in. NPT process connector, PN 23166-00 or 23166-01 (sold separately)	None, use 1 in. NPT process connector, PN 23166-00 or 23166-01 (sold separately)	None, must use Quik-Loc kit which includes 1 in. MNPT process connection	1-in. MNPT
Temperature Range	0-100°C (32-212°F)	0-100°C (32-212°F)	0-100°C (32-212°F)	—
Pressure Range-Hemi bulb	100-1136 kPa abs (0-150 psig)	100-1825 kPa abs (0-250 psig)	100-790 kPa abs (0-100 psig)	—
Pressure Range-Flat bulb	100-790 kPa abs (0-100 psig)	100-790 kPa abs (0-100 psig)	—	—
Minimum Conductivity	75 µS/cm, nominal	75 µS/cm, nominal	75 µS/cm, nominal	—
Preamplifier Options	Remote	Remote	Remote	—
Weight/Shipping Weight	0.45 kg/0.9 kg (1 lb/2 lb)	0.45 kg/0.9 kg (1 lb/2 lb)	0.45 kg/0.9 kg (1 lb/2 lb)	0.45 kg/0.9 kg (1 lb/2 lb)

PERCENT LINEARITY		
pH Range	396, 396VP, 397, 398, 398VP	
	GPHT Hemi	GPLR Hemi
0-2 pH	94%	93%
2-12 pH	99%	98%
12-13 pH	97%	95%
13-14 pH	92%	—

1.3 ORDERING INFORMATION

The **Model 396 pH Sensor** features your selection of glass electrode type, either the standard hemi bulb or the optional flat glass electrode combined with the coating resistant, polypropylene reference with gel filled electrolyte. The sensor is housed in a stainless steel body and is used with a 1 in. MNPT threaded process connector suitable for insertion, submersion, or flow through installations. The Model 396 is available without an integral preamplifier only and 15 ft of cable. Automatic temperature compensation is standard 3 K Balco or PT-100 RTD.



MODEL 396		TUpH INSERTION/SUBMERSION STAINLESS STEEL pH SENSOR
CODE	ANALYZER/TC COMPATIBILITY (Required Selection)	
50	For use with Models 1181, 1050, 1003 (3 K TC)	
54	For use with Models 54/e, 1054A/B, 1055, 2700, SCL-P, 81, 2081, 3081, and 4081 (Pt-100 RTD)	
CODE	OPTIONAL ITEMS	
62	Cable without BNC for wiring to 4081/3081/81/54 analyzers	
71	Flat bulb, GPLR	
396 - 54		EXAMPLE

The **Model 396VP insertion/submersion sensor** is the same as Model 396 except, instead of a cable on the back end of the sensor, it features a Variopol connector. The watertight Variopol sensor-to-cable connector uses a mating connector cable (ordered separately).



MODEL 396VP		TUpH INSERTION/SUBMERSION STAINLESS STEEL AND POLYPROPYLENE pH SENSOR (GPHT hemi bulb)
CODE	ANALYZER/TC COMPATIBILITY (Required Selection)	
50	For use with Models 1181, 1050, 1003 (3 K TC)	
54	For use with Models 54/e, 1054A/B, 1055, 2700, SCL-P, 81, 2081, 3081, and 4081 (Pt-100 RTD)	
CODE	OPTIONAL OPTIONS	
71	GPLR Flat bulb	
396VP - 54		EXAMPLE

The **Model 398 Sensor**, housed in a titanium tube and made with a Tefzel reference junction, can be used with a 1 inch MNPT process connector (purchased separately). The sensor is available with a hemi bulb glass pH electrode or a platinum and glass ORP electrode and with Pt100 or 3K temperature compensation. The 398 is provided with a standard 15 ft cable. A preamplifier must be used if the sensor is more than 15 ft from the analyzer/transmitter. Junction box kits with preamplifiers must be ordered separately. Process connector must also be ordered separately.



MODEL 398 TU _p H INSERTION/SUBMERSION TITANIUM pH SENSOR	
CODE	MEASURING ELECTRODE TYPE (Required Selection)
10	GPHT hemi glass, General Purpose High Temperature (0-14 pH)
12	ORP
13	Flat Bulb, GPLR
CODE	O-RING MATERIAL (Required Selection)
30	EPDM
31	Viton
32	Kalrez (recommended for applications with Chlorine Dioxide)
CODE	ANALYZER/TC COMPATIBILITY (Required Selection)
50	For Models 1181 (3K TC) [no T.C. if ordered with option -12 (ORP)]
54	For Models 54/e, 1054A/B, 1055, 2700, 81, 2081, 3081, 4081, SCL-P, and Solu Cube (Pt-100 RTD)
CODE	OPTIONAL SELECTIONS (see drawings on page 4)
62	No BNC (Not Valid w/Option 50) for wiring directly to 54/e, 1055, 81, 3081, and 4081 Transmitter/Analyzers
398 - 10 - 32 - 54 EXAMPLE	

The **Model 398VP insertion/submersion sensor** is the same as Model 398, except the cable is replaced with a Variopol connector. The watertight Variopol sensor-to-cable connector uses the mating connector cable (ordered separately).



MODEL 398VP TU _p H INSERTION/SUBMERSION TITANIUM AND TEFZEL pH/ORP SENSOR	
CODE	MEASURING ELECTRODE TYPE (Required Selection)
10	GPHT hemi glass, General Purpose High Temperature (0-14 pH)
12	ORP
13	Flat
CODE	O-RING MATERIAL (Required Selection)
30	EPDM
31	Viton
32	Kalrez (recommended for applications with Chlorine Dioxide)
CODE	ANALYZER/TC COMPATIBILITY (Required Selection)
50	For Models 1181 (3K TC) [no T.C. if ordered with option -12 (ORP)]
54	For Models 54/e, 1054A/B, 1055, 2700, 81, 2081, 3081, 4081, SCL-P, and Solu Cube (Pt-100 RTD)
398VP - 10 - 32 - 54 EXAMPLE	

The **TUpH Model 397 pH Sensor** is housed in a polypropylene body and is designed to be used with the Quik-Loc Kit. The sensor includes a large general purpose (GPHT) glass pH electrode and a large area polypropylene reference junction with gel filled reference electrolyte. The Model 397 is available without an integral preamplifier only and 15 ft (4.6 m) of cable.



MODEL 397 TUpH pH SENSOR	
CODE	PREAMPLIFIER/CABLE (Required Selection)
02	Without integral preamplifier, 15 ft (4.6 m) cable
CODE	MEASURING ELECTRODE TYPE (Required Selection)
10	GPHT, General Purpose glass (0-14 pH)
CODE	ANALYZER/TC COMPATIBILITY (Required Selection)
50	For Models 1181, 1050, 1003 (3 K Balco TC)
54	For Models 1054, 1055, 54e, 81, 5081, 3081, 4081, 2081; Xmt (PT-100 RTD)
CODE	OPTIONAL OPTIONS
62	Cable without BNC for wiring to 54/e, 1055, 81, 3081, 4081 analyzers, Xmt

FOR FIRST TIME 397/QUIK-LOC INSTALLATIONS, USING THE FOLLOWING GUIDE IS RECOMMENDED:

<p>1. Quik-Loc Mounting (required for all first time installations)</p> <p>Choose one: PN 23757-00, Quik-Loc Kit: for use in 1 in. tees; insertion depth 1.4 in. (35 mm) PN 23757-01, Quik-Loc Kit: for use in 1-1/2 in. and 2 in. tees; insertion depth 2 in. (50 mm)</p> <p>2. Remote Junction Boxes (optional, recommended for sensor to analyzer distances of more than 15 ft)</p> <p>Choose one: PN 23555-00 includes preamplifier for Models 54, 81, 3081, 4081 PN 23309-03 and PN 22698-02 plug-in preamplifier for Model 1181 Analyzer PN 23309-04 and PN 22698-03 plug-in preamplifier for Models 1054 series, 2054, and 2081 Analyzers PN 23054-03 includes preamplifier for Solu Cube Model 2700</p> <p>3. Extension cables (used with remote junction boxes)</p> <p>Choose one: PN 23646-01, 11 conductor, shielded, prepped PN 9200273, 11 conductor, shielded, unprepped</p> <p>4. Wiring Aids</p> <p>Choose one: PN 9120531 BNC splitter, used in place of option -62 or BNC coax prepping for connections to junction box (PN 23555-00); Models 1181, 1054, 2081, 54, 81, 3081, 4081; Solu Comp (SCL-P-014); and Model 2700 Preamplifier (PN 23054-03) NONE: No wiring aids required for connections to Models 1054A, 1054B, 2054, or preamplifiers PN 22698-02 or 22698-03</p>
--

**FOR FIRST TIME 396, 396VP, 398, AND 398VP INSTALLATIONS,
ROSEMOUNT ANALYTICAL RECOMMENDS USING THE FOLLOWING GUIDE:****1. Process Connector Accessories (required for all first time installations with 1-inch process connection threads)**

Choose one: PN 23166-00, 316 SST, 1 in. x 1 in. NPT process connector, with EPDM o-ring
 PN 23166-01, Titanium, 1 in. x 1 in. NPT process connector, with EPDM o-ring
 PN 9510066, Nylon, 1 in. x 1 in. NPT process connector (submersion only)

Choose one (optional process connector o-rings)
 PN 9550220, Kalrez o-ring, 2-214
 PN 9550099, Viton o-ring, 2-214

2. Variopol Cable (required for all first time installations) of Models 396VP and 398VP

Choose one: PN 23645-06, 15 ft cable with mating VP connector, prepped with BNC on analyzer end
 PN 23645-07, 15 ft cable with mating VP connector, prepped without BNC on analyzer end*

3. Mounting Accessories (optional)

Choose one: PN 915240-03 PVC flow through tee, 3/4 in. NPT process connection
 PN 915240-04 PVC flow through tee, 1 in. NPT process connection
 PN 915240-05 PVC flow through tee, 1 1/2 in. NPT process connection
 PN 11275-01 Sensor handrail mounting assembly
 PN 2002011 1-1/2 in. CPVC Tee with 1 in. FNPT connection
 PN 23728-00 Low Flow Cell, acrylic

4. Remote Junction Boxes (optional, recommended for sensor to analyzer distances of more than 15 ft)

Choose one: PN 23555-00 includes preamplifier for Models 54/e, 1055, 81, 3081, 4081
 PN 23309-03 and PN 22698-02 plug-in preamplifier for Model 1181 Analyzer
 PN 23309-04 and PN 22698-03 plug-in preamplifier for Models 1054 series, 2054, 2081 Analyzers
 PN 23054-03 includes preamplifier for Solu Cube Model 2700

5. Extension cables (used with remote junction boxes)

Choose one: PN 23646-01, 11 conductor, shielded, prepped
 PN 9200273, 11 conductor, shielded, unprepped

6. Wiring Aids

Choose one: PN 9120531 BNC splitter, used in place of option -62 or BNC coax prepping for connections to junction box (PN 23555-00); Models 54, 1055, 1054, 81, 1181, 2081, 3081, 4081; SoluComp (SCL-P-014); and Model 2700 Preamplifier (PN 23054-03)
 NONE: No wiring aids required for connections to preamplifier PN 22698-02, preamplifier PN 22698-03, or Models 1054A, 1054B, and 2054

**Used for connections to Models 54/e, 1055, 1054, 81, 1181, 2081, 3081, 4081, and remote junction box PN 23555-00.*

ADDITIONAL ACCESSORIES FOR MODEL 396, 396VP, 398 AND 398VP TUpH SENSORS

PART NUMBER	DESCRIPTION
33046-00	Ferrule 1 in., split 316 SS
33211-00	Adapter retrofit for PN 915240-04
9550167	EPDM O-ring for process connector (PN 23166-00)
9310100	Ferrule, 1 in. Teflon ¹
9310096	Nut, Swage, 1 in. stainless steel
9550167	O-ring, 2-214 EPDM

¹ Teflon is a registered trademark of E.I. du Pont de Nemours & Co.

ADDITIONAL ACCESSORIES FOR MODEL 397 TUpH SENSOR AND THE QUIK-LOC KIT

PART NUMBER	DESCRIPTION
23753-00	PEEK replacement adapter for Quik-Loc kit (PN 23757-01)
23753-01	PEEK replacement adapter for Quik-Loc kit (PN 23757-00)
9160441	1 in. MNPT 316 stainless steel coupler
9160442	1 in. Plug, stainless steel
9160447	1 in. EP Gasket for coupler
2002011	1-1/2 in. CPVC Tee with 1 in. FNPT Connection

ADDITIONAL ACCESSORIES USED FOR MODELS 396, 396VP, 397, 398, AND 398VP TUpH SENSORS

PART NUMBER	DESCRIPTION
22698-00	Preamplifier plug-in for J-box, 1003 compatible
22698-02	Preamplifier plug-in for J-box, 1181/1050 compatible
22698-03	Preamplifier plug-in for J-box, 1054A/B, 2054,2081 compatible
22743-01	Pt 100 preamplifier, 1181 compatible
22744-01	3K Preamplifier, 1181 compatible
23054-03	Remote J-box with preamplifier for Solu Cube Model 2700
23309-03	Remote Junction box, for preamplifier Model 1181
23309-04	Remote Junction box, for preamplifier Model 1054 Series, 2054, 2081
23555-00	Remote Junction box, with preamplifier, 54/e, 81, 3081, 4081 compatible
23557-00	Preamplifier for Junction box for Models 54/e, 1055, 81, 3081, 4081
23646-01	Extension cable 11 conductor, shielded, prepped
9200273	Extension cable 11 conductor, shielded, unprepped
9210012	Buffer solution, 4.01 pH, 16 oz.
9210013	Buffer solution, 6.86 pH, 16 oz.
9210014	Buffer solution, 9.18 pH, 16 oz.
2001492	Stainless Steel Tag, Specify Marking
9200254	Cable, 4 cond., 22 AWG, 2 shielded pair

SECTION 2.0 INSTALLATION

2.1 UNPACKING AND INSPECTION. Inspect the outside of the carton for any damage. If damage is detected, contact the carrier immediately. Inspect the instrument and hardware. Make sure all the items in the packing list are present and in good condition. Notify the factory if any part is missing. If the sensor appears to be in satisfactory condition, proceed to Section 2.2, Mounting.

NOTE

Save the original packing cartons and materials as most carriers require proof of damage due to mishandling, etc. Also, if it is necessary to return the instrument to the factory, you must pack the instrument in the same manner as it was received. Refer to Section 6 for return instructions. If the sensor is to be stored, the vinyl boot should be filled with pH buffer solution and replaced on sensor tip until ready to use.

WARNING

Glass electrode must be wetted at all times (in storage and in line) to maximize sensor life.

2.2 MOUNTING. Each sensor has been designed to be located in industrial process environments. Temperature and pressure limitations must not be exceeded at any time. A caution or warning label regarding this matter is attached to each sensor. For insertion, transfer the label as shown on label instructions. See Figure 2-2. For submersion applications, first note limits then remove and discard label.

NOTE

Before mounting the sensor, shake down the sensor to remove any air bubbles that may be present at the tip of the pH glass bulb. In most cases, the pH sensor can simply be installed as shipped and readings with an accuracy of ± 0.6 pH may be obtained. To obtain greater accuracy or to verify proper operation, the sensor must be calibrated as a loop with its compatible analyzer or transmitter.

2.2.1 Flow Through and Insertion Mounting for Models 396, 396VP, 398, and 398VP. The Models 396, 396VP, 398, and 398VP Sensors can be used with a 1 inch MNPT process connector at the front of the sensor for mounting into a 1-1/2 inch tee or the process. See Figure 2-1 for installation configurations.

2.2.2 Submersion Mounting for Models 396, 396VP, 398, and 398VP. The Models 396, 396VP, 398, and 398VP Sensors also have a 1 inch MNPT process connector available for use on the back of the sensor. Tapered pipe threads in plastic fittings tend to loosen after installation. It is therefore recommended that Teflon tape be used on the threads and that the tightness of the connection be checked frequently to assure that no loosening has occurred. To prevent rain water or condensation from running into the sensor, a weatherproof junction box is recommended (see Figure 2-4). The sensor cable must be run through a protective conduit for isolation from electrical interference or physical abuse from the process. The sensor should be installed within 80° of vertical, with the electrode facing down. The sensor's cable should not be run with power or control wiring.

2.2.3 Quik-Loc Mounting for Model 397. The Quik-Loc mounting is used with the Model 397 TUpH sensor only.

SAFETY WARNING

It is recommended that a thermometer, drain valve to relieve pressure and pressure gauge be inserted near the Quik-Loc assembly (see Figure 2-5).



WARNING

Once the Quik-Loc unit is installed the operator should wait for the process to cool to a safe temperature, use the pressure drain valve to relieve all process pressure and observe the pressure on the pressure gauge for proper removal of the sensor without spray or bodily injury. The Quik-Loc kit used with the 397 TUpH sensor is not recommended for use with hazardous, corrosive, or strong oxidizing chemicals due to a risk of spray or bodily injury.

Wrap the pipe threads of the Twin-Kam Kamloc coupler with Teflon tape before placing it into the process pipe. The coupler can be connected to any 1 in. process connection and must be mounted within 80° of vertical, with the electrode facing down. Once the coupler is in place, the adapter should be positioned onto the back end of the sensor. (See Figure 2-5) Remove the parafilm wrapping from the two O-rings on the sensor, grease the o-rings with the lube provided, and feed the sensor cable through the adapter. Once the adapter is slipped over the sensor's back end, the retaining ring (which is included with every 397 sensor) should be installed on the black, grooved, back end of the sensor body. The retaining ring secures the sensor into the adapter. The adapter/sensor assembly is now ready to be inserted into the coupler. With both arms of the coupler in the released position, insert the adapter/sensor assembly into the coupler.

NOTE

The adapter can not be inserted completely or properly unless both arms are in the fully released position (see Figure 2-5).

Once the adapter has been properly placed in the coupler, both arms should be positioned in the locked position. A Sur-Loc™ 1 spring arm has been provided on one arm so that the "arm cannot be opened until the spring is released."²

NOTE

The sensor may obstruct flow through smaller pipes.

Once the arms of the coupler have been locked in position, use tamper-evident safety wire on the metal rings of the Twin-Kam arms to prevent unauthorized and/or untrained personnel from using the Quik-Loc unit.

SAFETY WARNING

It is the responsibility of each company using the Quik-Loc Kit/ 397 TUpH Sensor to train personnel of the injury risks associated with using a quick-release coupler that is placed in a hot or pressurized process.



The Quik-Loc unit should be used only within the pressure and temperature limits stated for the Model 397 sensor in Section 1.2.

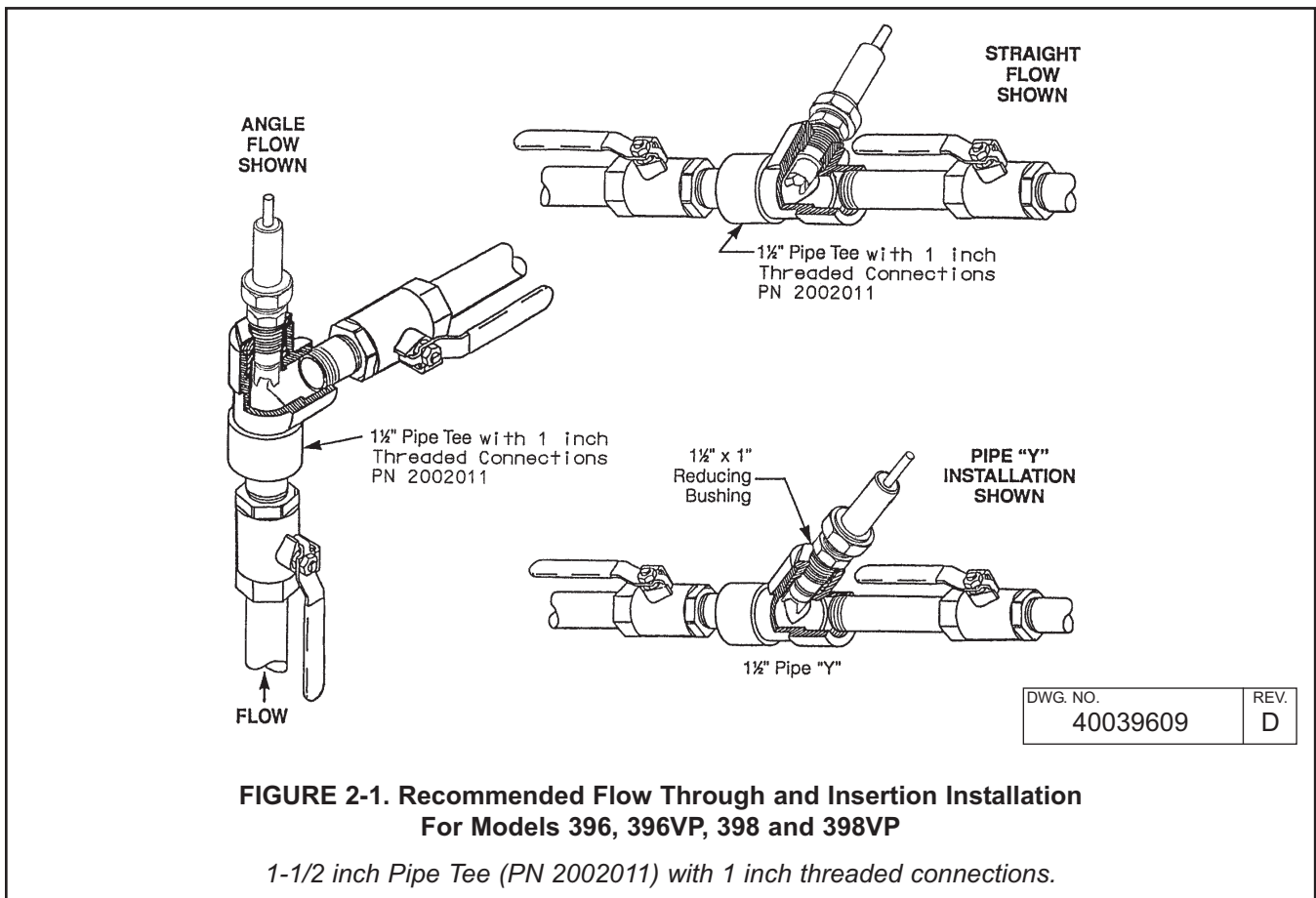

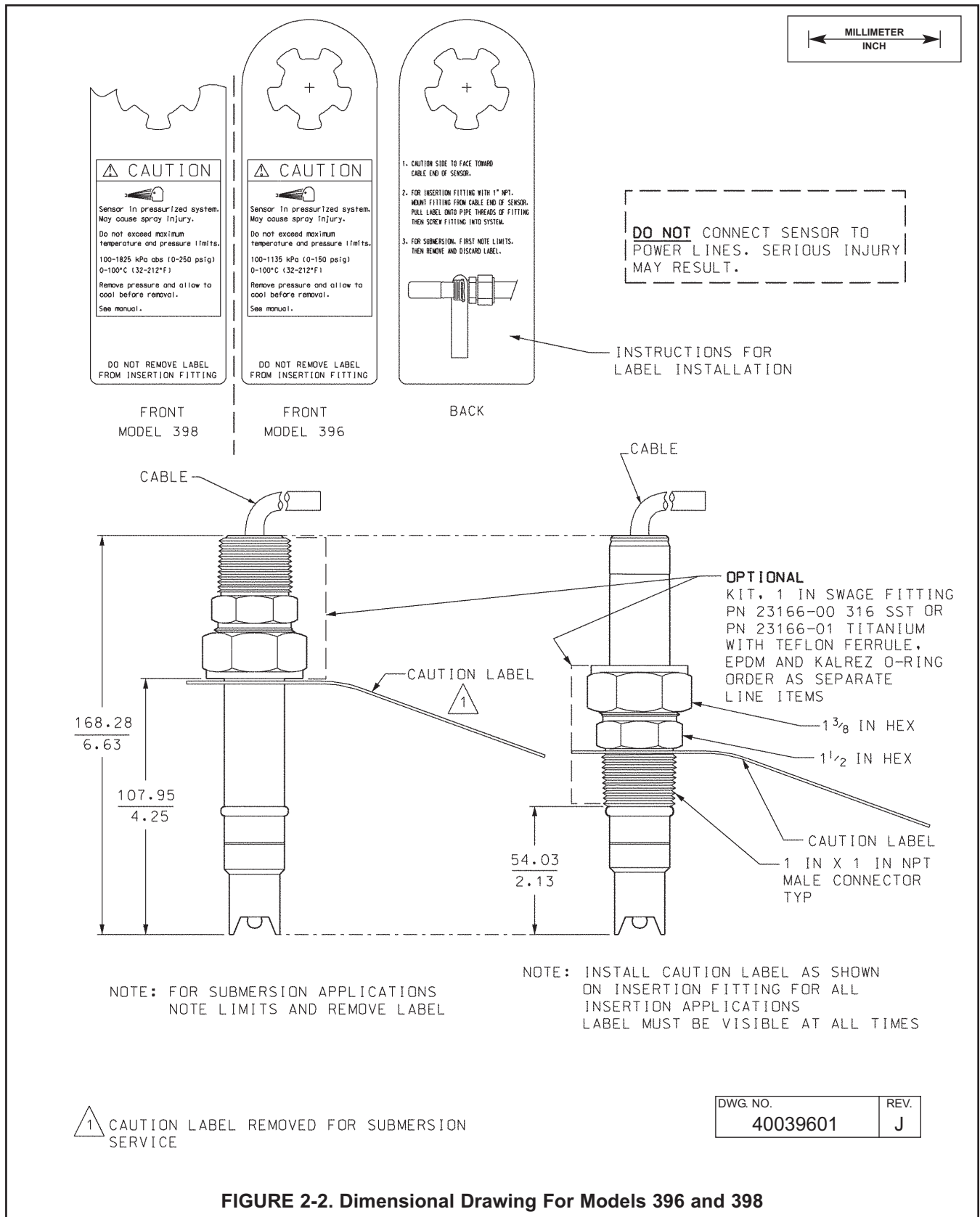

FIGURE 2-2. Dimensional Drawing For Models 396 and 398

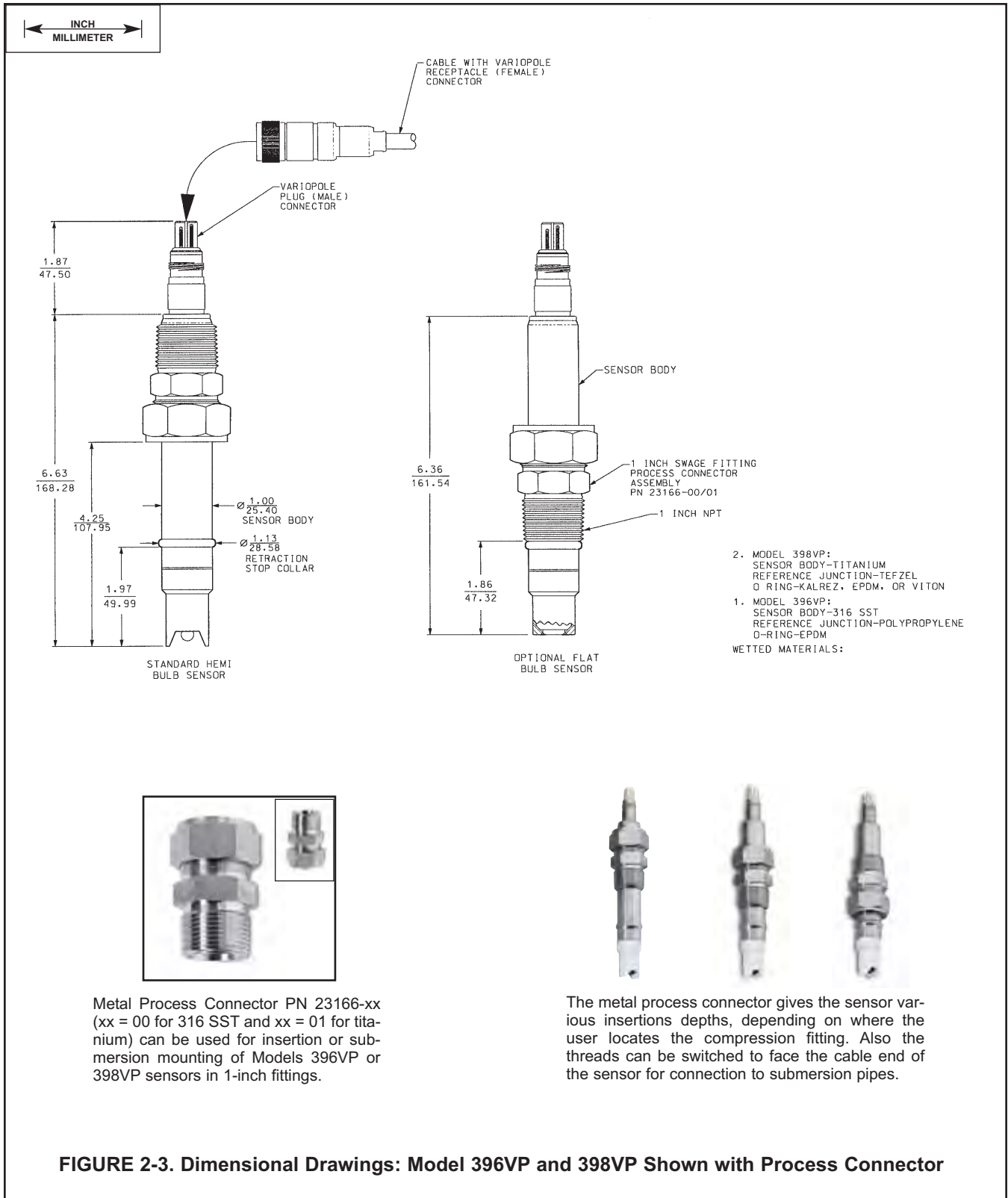

FIGURE 2-3. Dimensional Drawings: Model 396VP and 398VP Shown with Process Connector

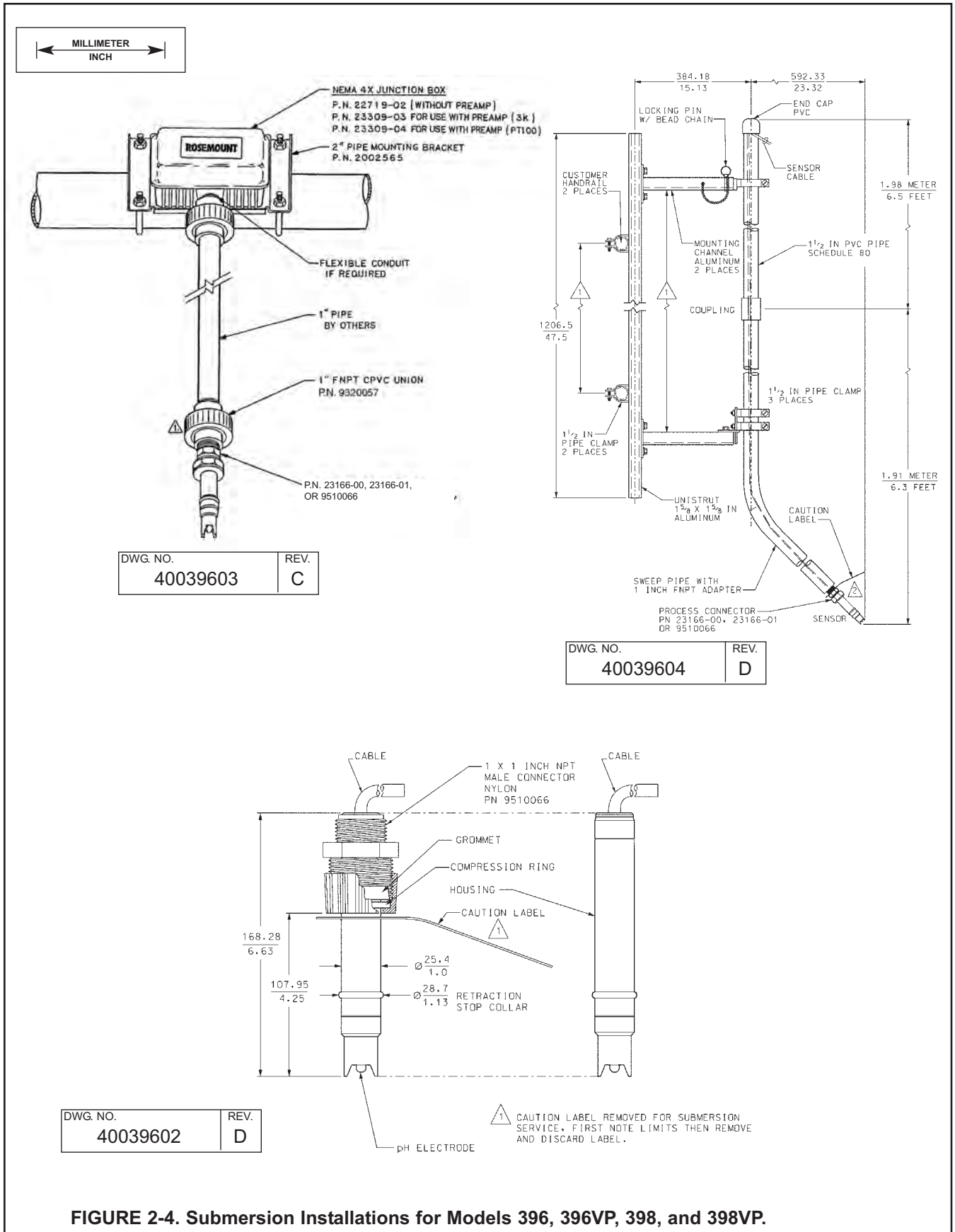

FIGURE 2-4. Submersion Installations for Models 396, 396VP, 398, and 398VP.

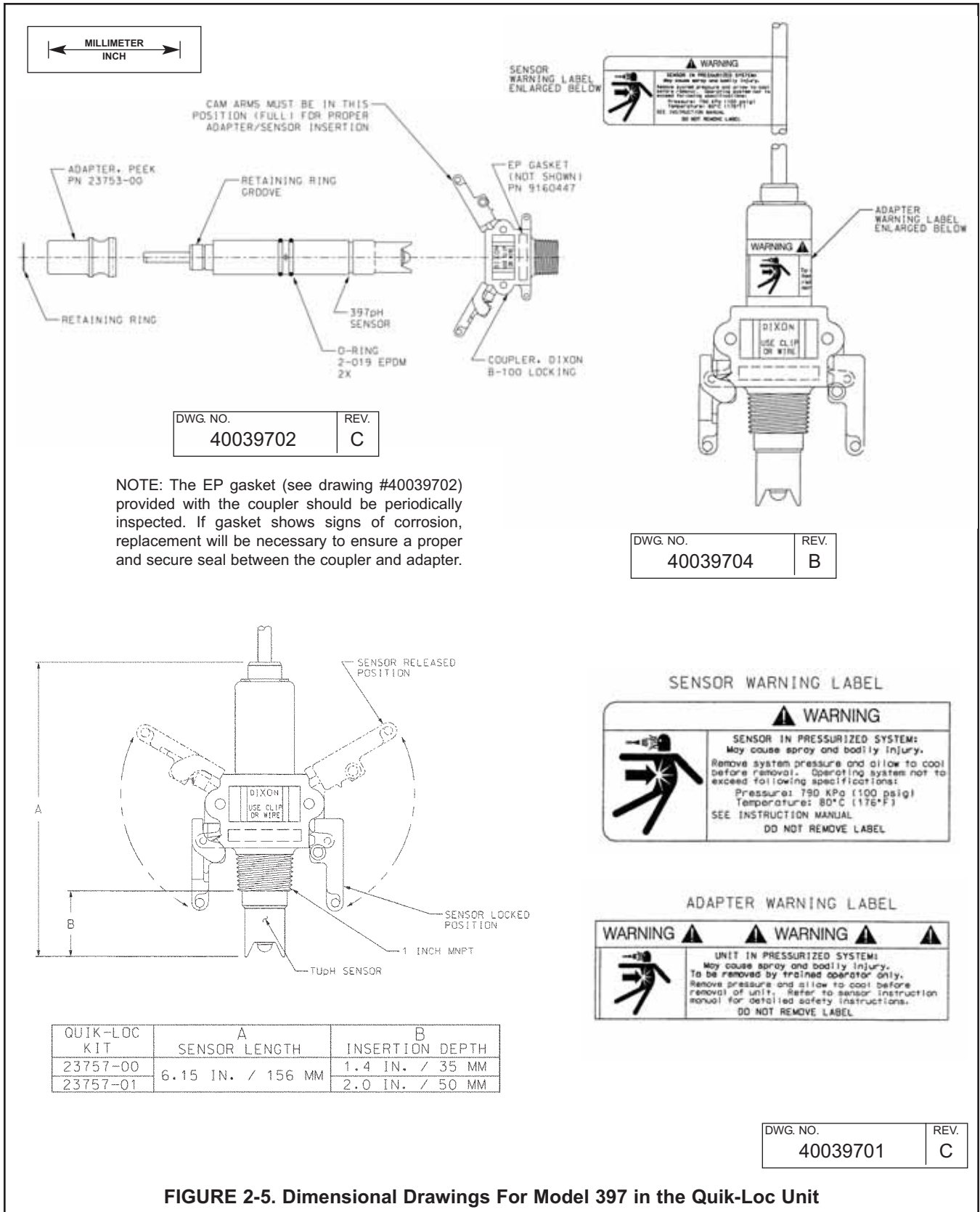

FIGURE 2-5. Dimensional Drawings For Model 397 in the Quik-Loc Unit

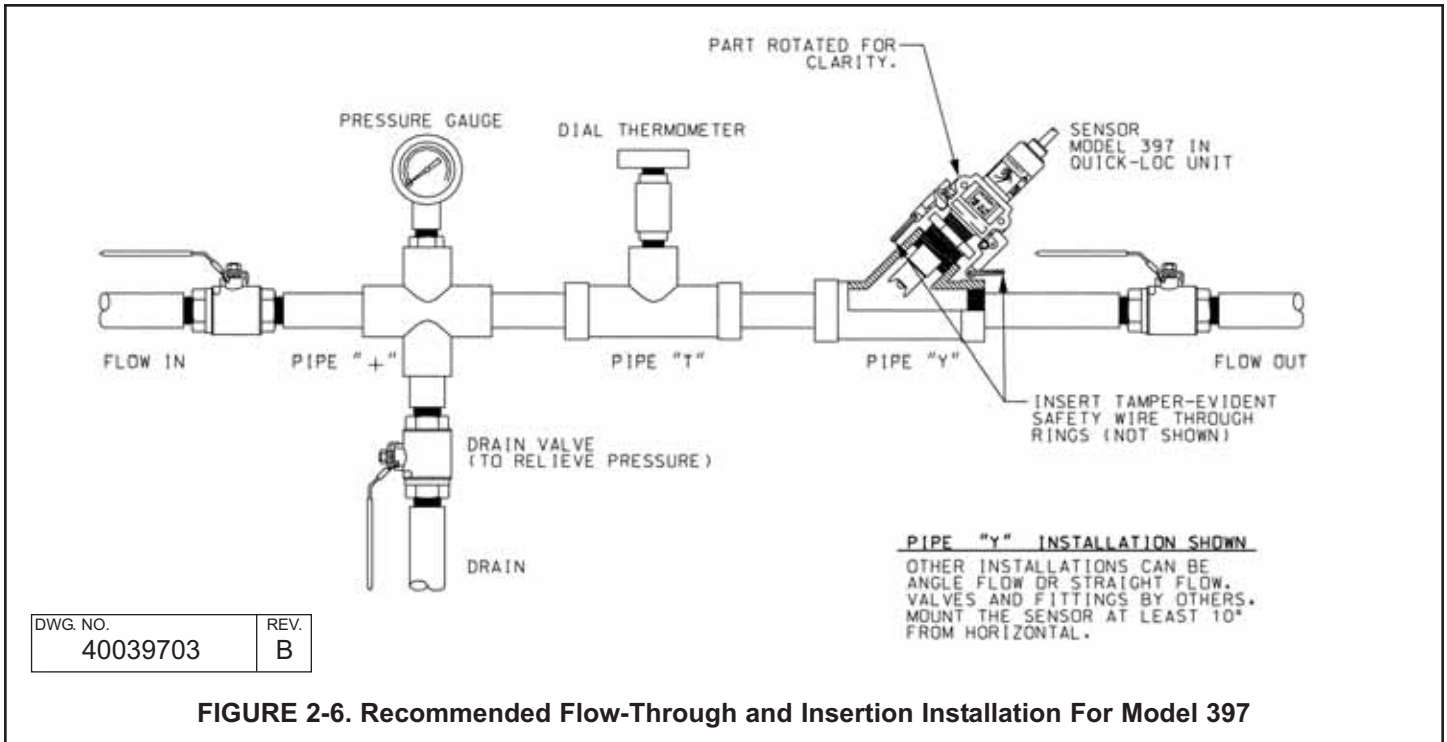

FIGURE 2-6. Recommended Flow-Through and Insertion Installation For Model 397

2.3 ELECTRICAL INSTALLATION.

The Models 396, 396VP, 397, 398, and 398VP are for use with a remote preamplifier. Each sensor comes with either a special 15 ft low noise coax cable or a Variopol (VP) connector, which is used with a mating Variopol cable. The cable should be handled carefully, and kept dry and free of corrosive chemicals at all times. Extreme care should be used to prevent the cable from being twisted, damaged or scraped by rough, sharp edges or surfaces. Please refer to Figures 2-7 thru 2-18 for wiring Models 396, 397, and 398.

Please refer to Figures 2-19 thru 2-36 for wiring Models 396VP and 398VP.

DANGER

DO NOT CONNECT SENSOR CABLE TO POWER LINES. SERIOUS INJURY MAY RESULT.

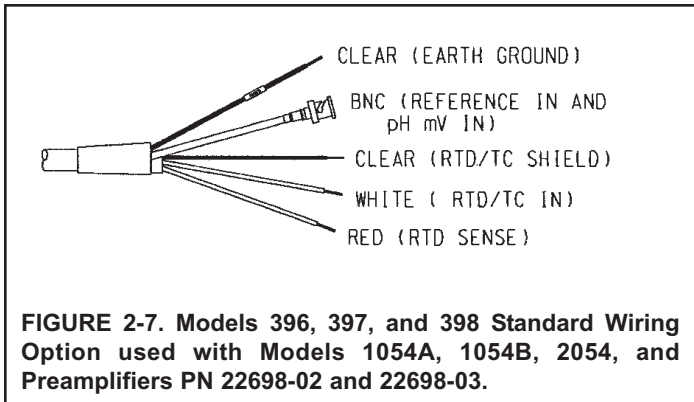

FIGURE 2-7. Models 396, 397, and 398 Standard Wiring Option used with Models 1054A, 1054B, 2054, and Preamplifiers PN 22698-02 and 22698-03.

NOTE

Remove electrical tape or shrink sleeve from gray reference wire before connecting wire to terminal.

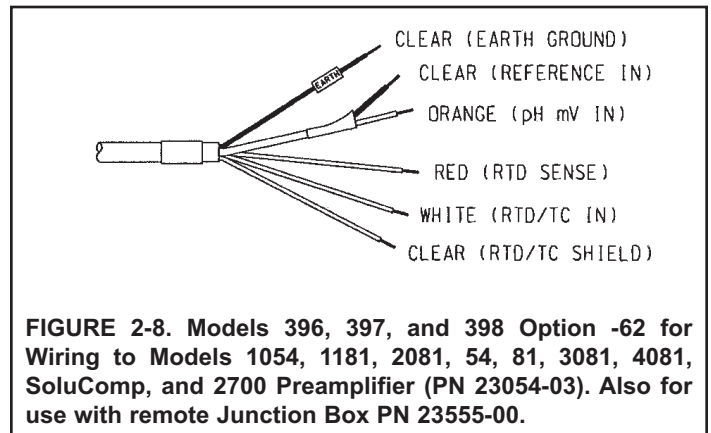
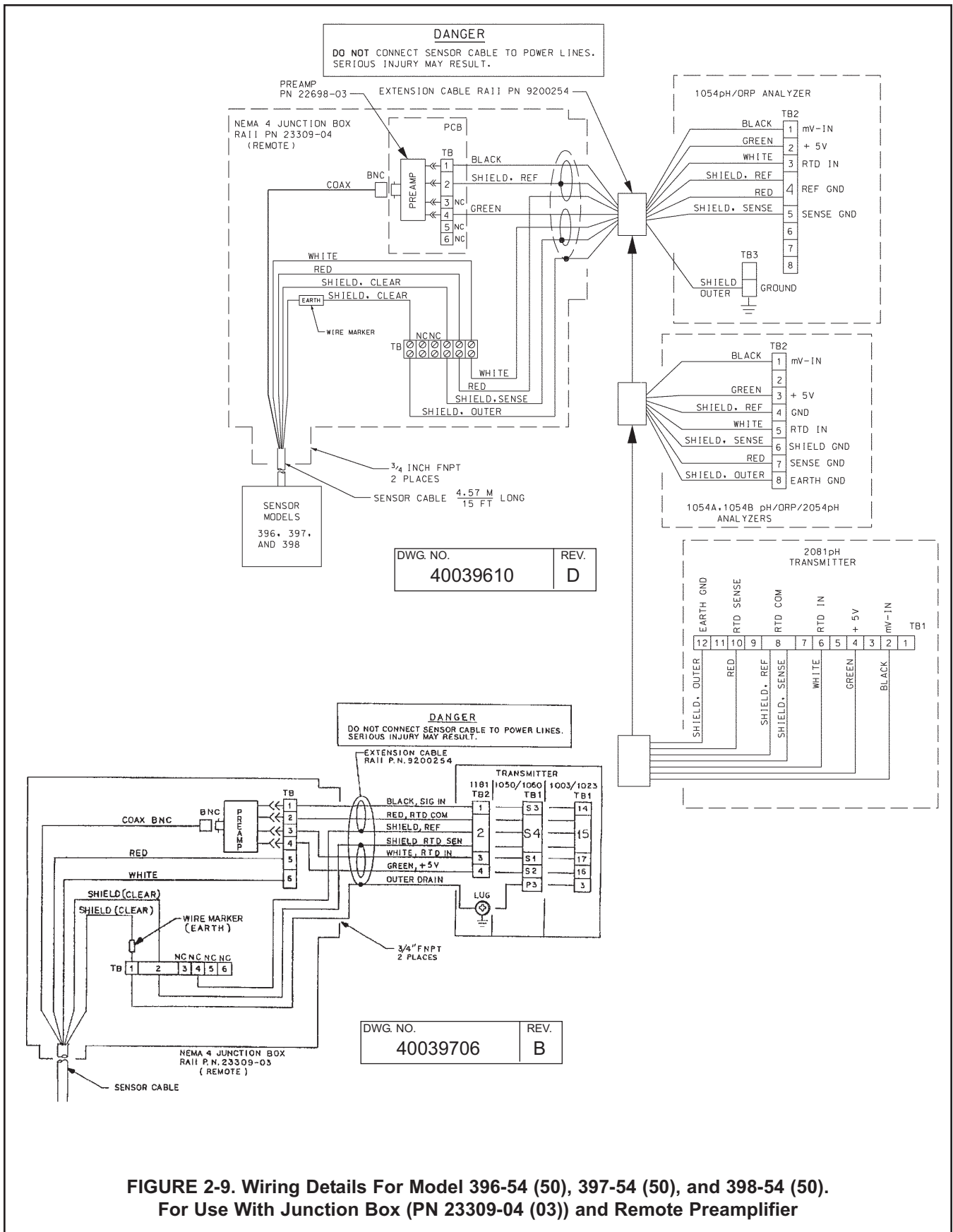
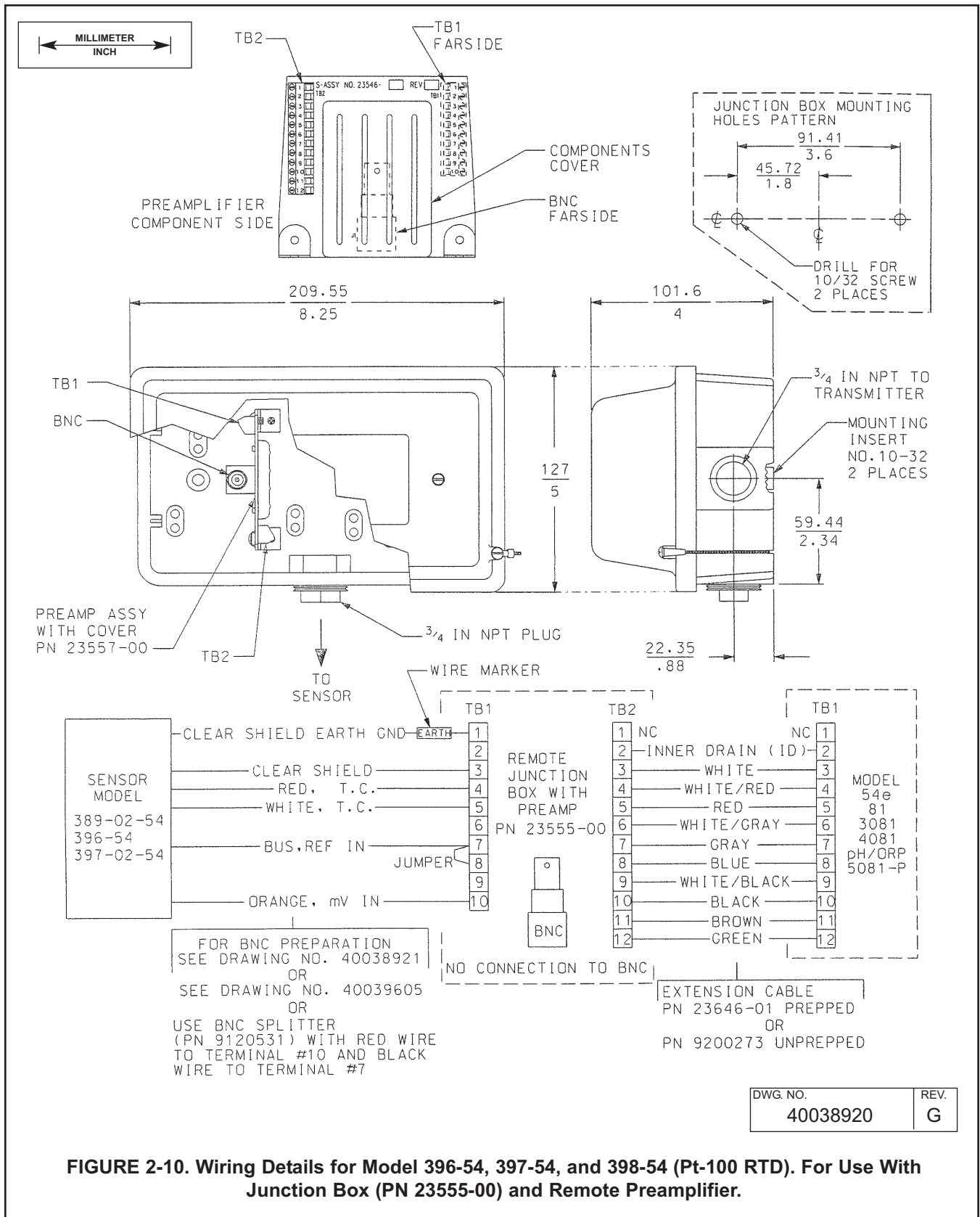
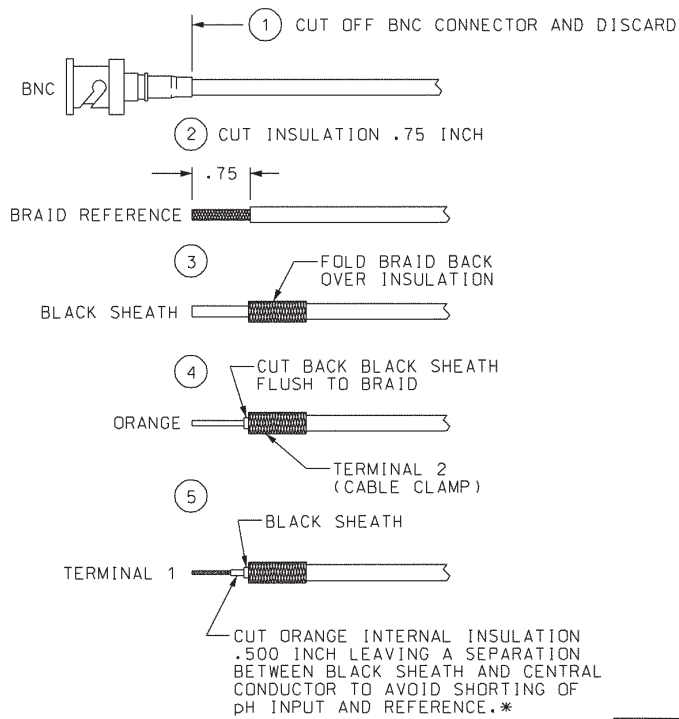

FIGURE 2-8. Models 396, 397, and 398 Option -62 for Wiring to Models 1054, 1181, 2081, 54, 81, 3081, 4081, SoluComp, and 2700 Preamplifier (PN 23054-03). Also for use with remote Junction Box PN 23555-00.





PREPARE THE COAX CABLE AS FOLLOWS:



* NOTE: THE BLACK SHEATH IS CONDUCTIVE

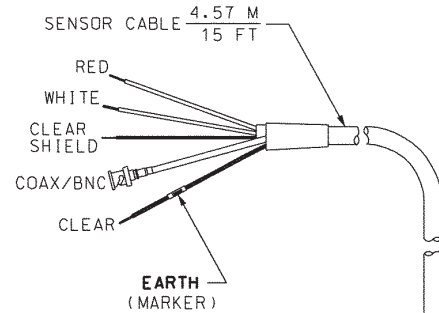

MODELS
389-02-54/54
396-50/54
397-02-50/54
398-50/54

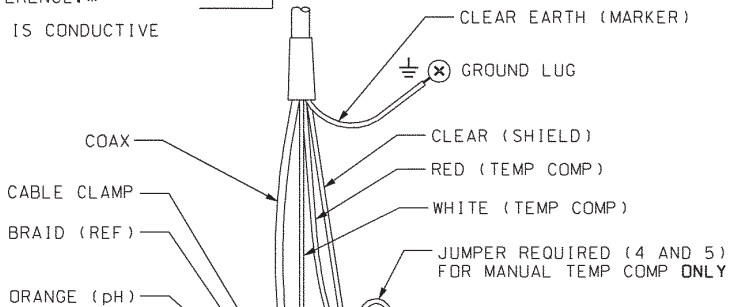

DO NOT CONNECT SENSOR CABLE TO POWER LINES. SERIOUS INJURY MAY RESULT

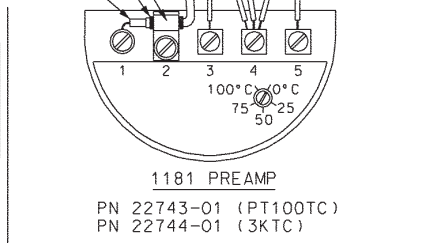

DWG. NO.	REV.
40039607	D

FIGURE 2-11. Wiring Details For Models 396, 397, and 398. For Use With Model 1181 pH.

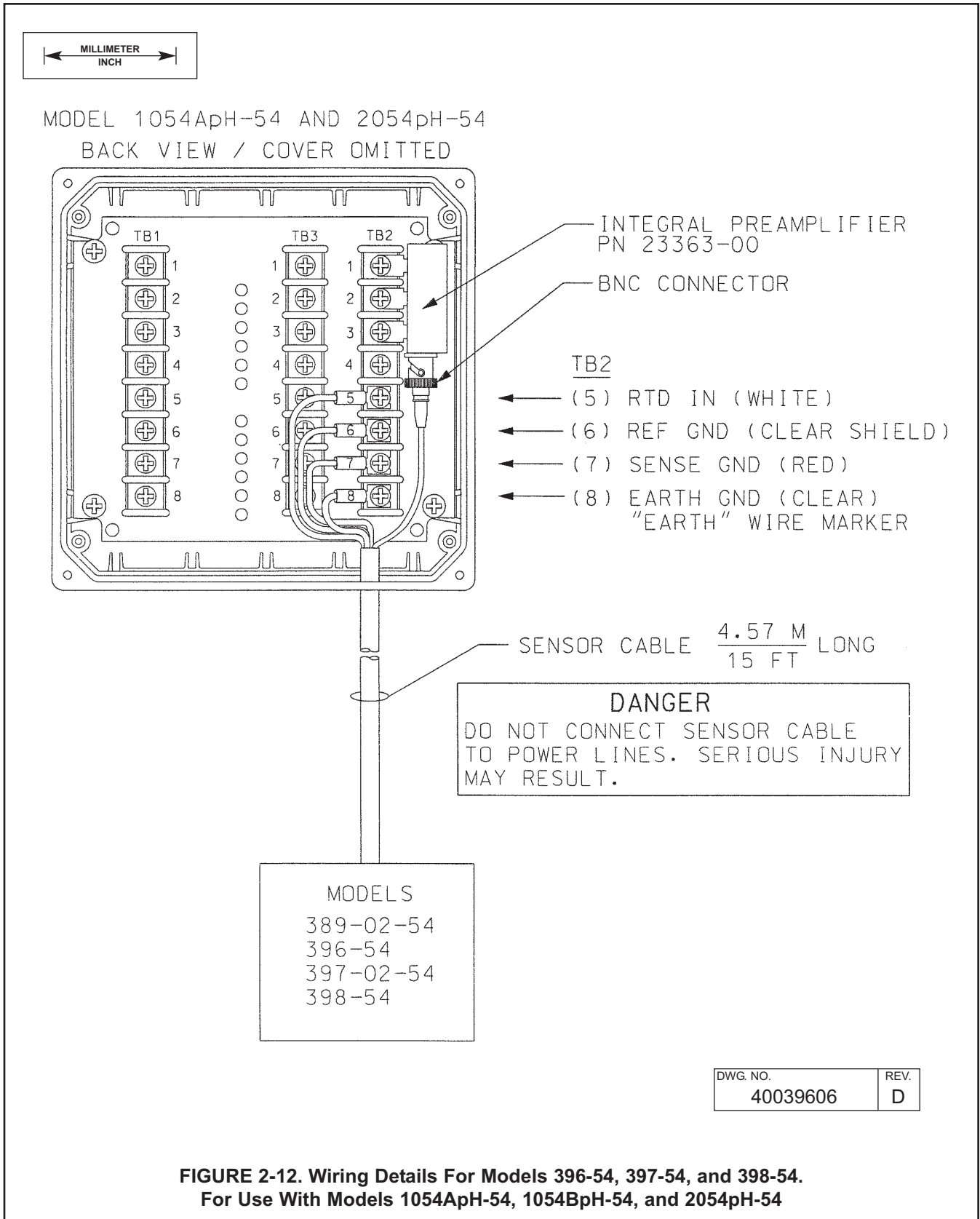

**FIGURE 2-12. Wiring Details For Models 396-54, 397-54, and 398-54.
For Use With Models 1054ApH-54, 1054BpH-54, and 2054pH-54**

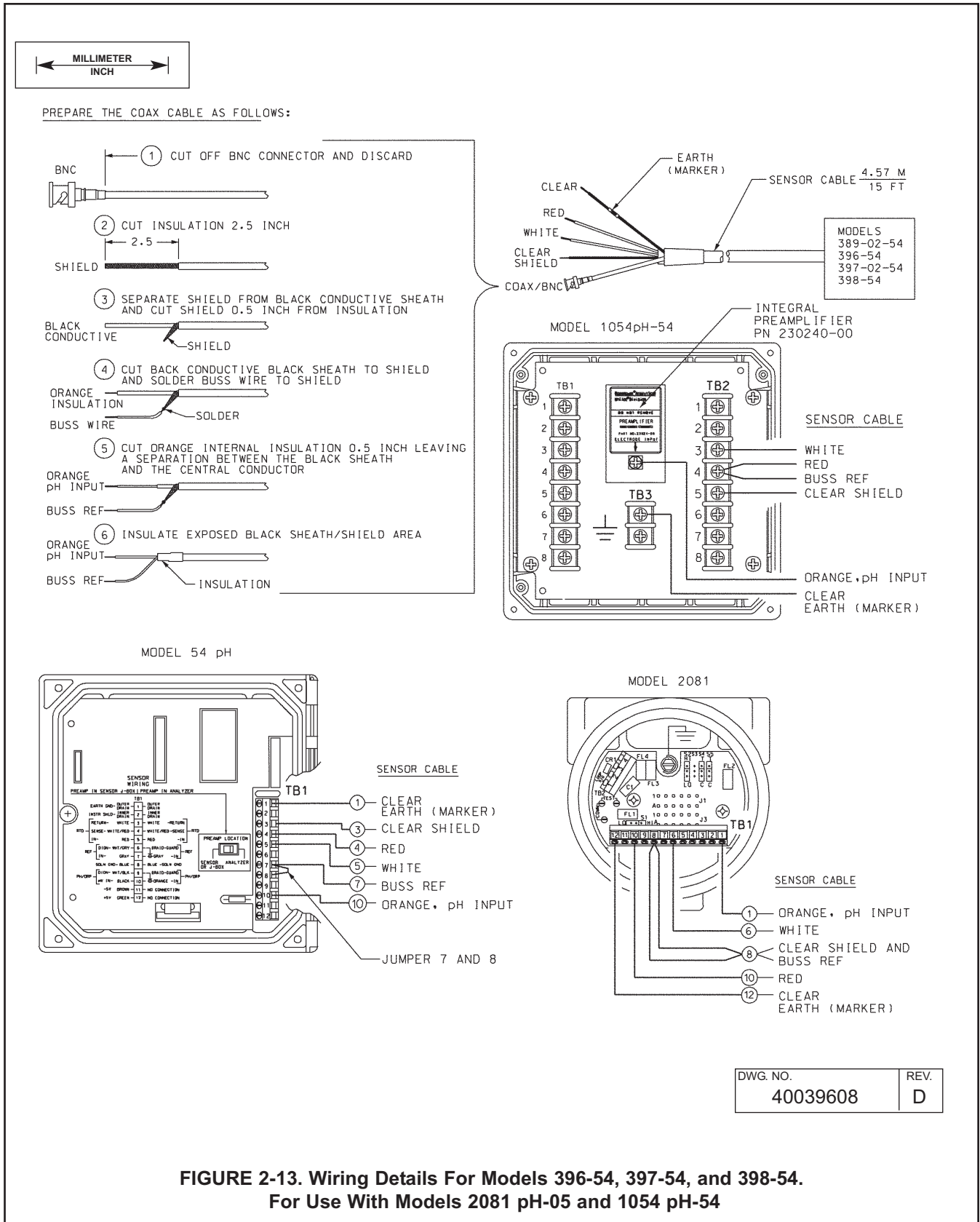

**FIGURE 2-13. Wiring Details For Models 396-54, 397-54, and 398-54.
For Use With Models 2081 pH-05 and 1054 pH-54**



PREPARE THE COAX CABLE AS FOLLOWS:

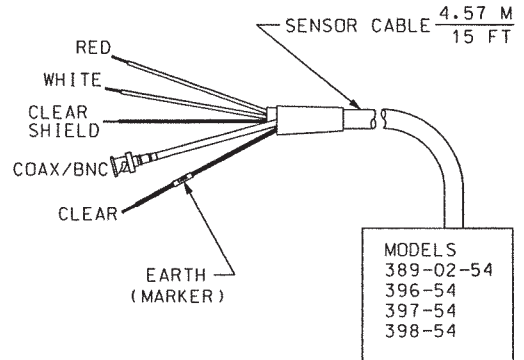
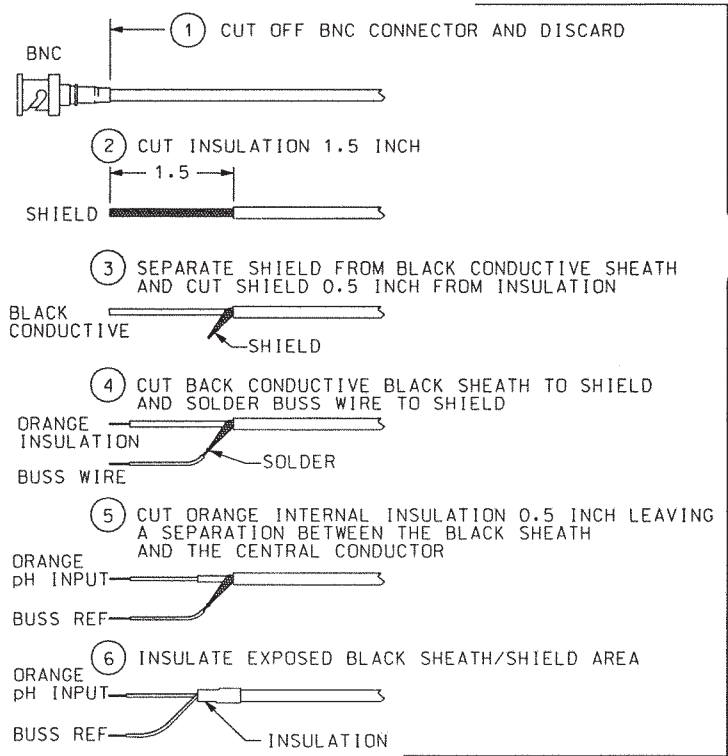

MODELS
389-02-54
396-54
397-54
398-54

DWG. NO. 40039605 REV. F

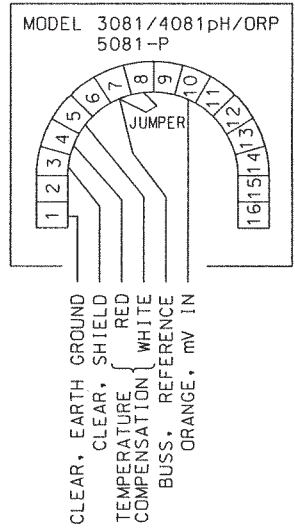
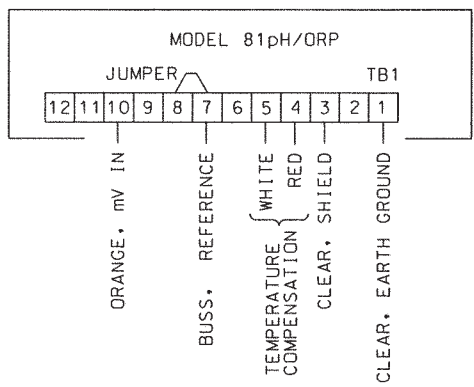
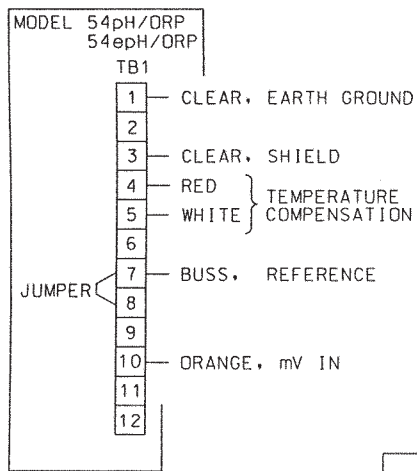

NON-DIAGNOSTIC pH SENSOR WITHOUT PREAMPLIFIER AND SOLUTION GROUND

FIGURE 2-14. Wiring Details For Models 396-54 , 397-54, and 398-54.
For Use With Models 54, 54e, 81, 3081, 4081, and 5081.



PREPARE THE COAX CABLE AS FOLLOWS:

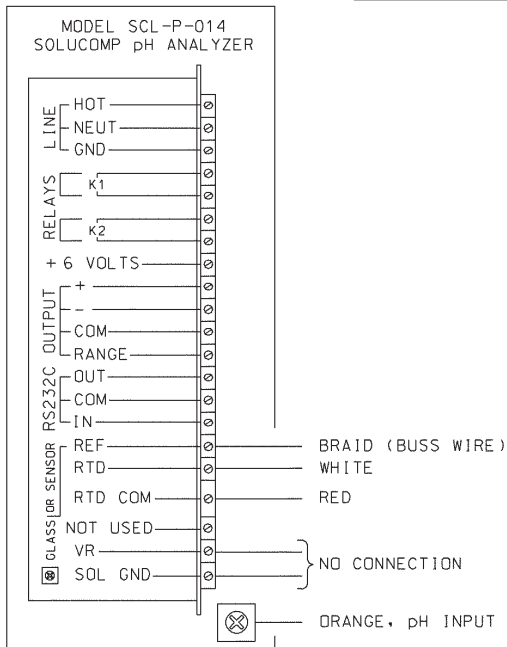
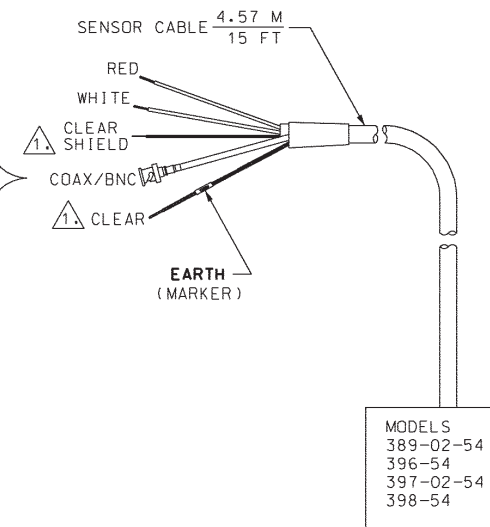
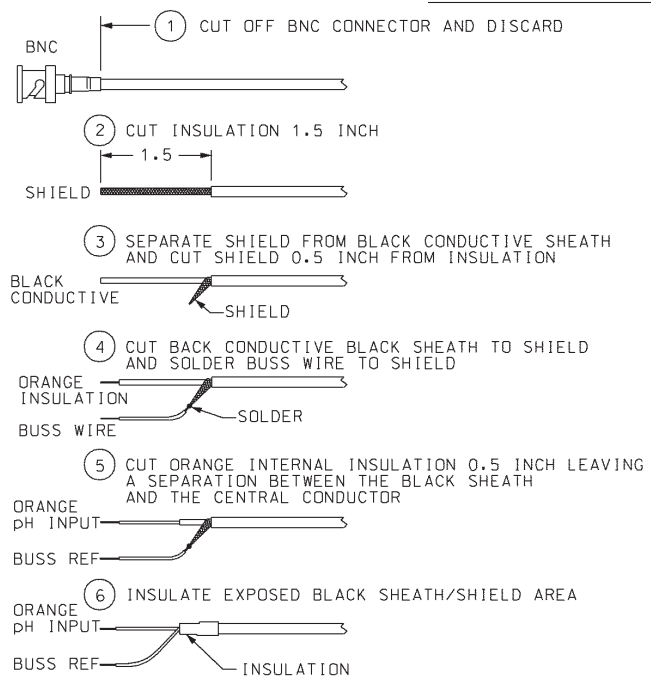

1. CUT OFF THE CLEAR SHIELD AND CLEAR EARTH WIRES BEFORE CONNECTING THE SCL-P-014 TERMINALS.

DWG. NO. 40039611	REV. D
----------------------	-----------

FIGURE 2-15. Wiring Details For Models 396-54 , 397-54, and 398-54.
For Use With SoluComp Model SCL-P-014.

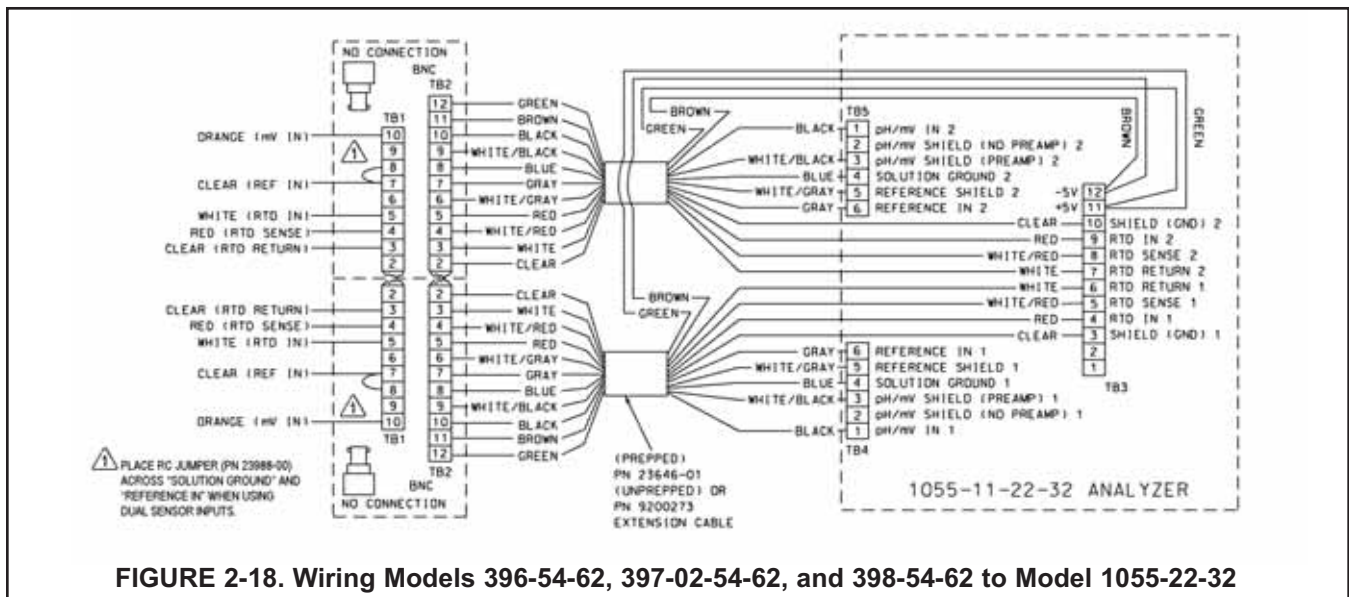
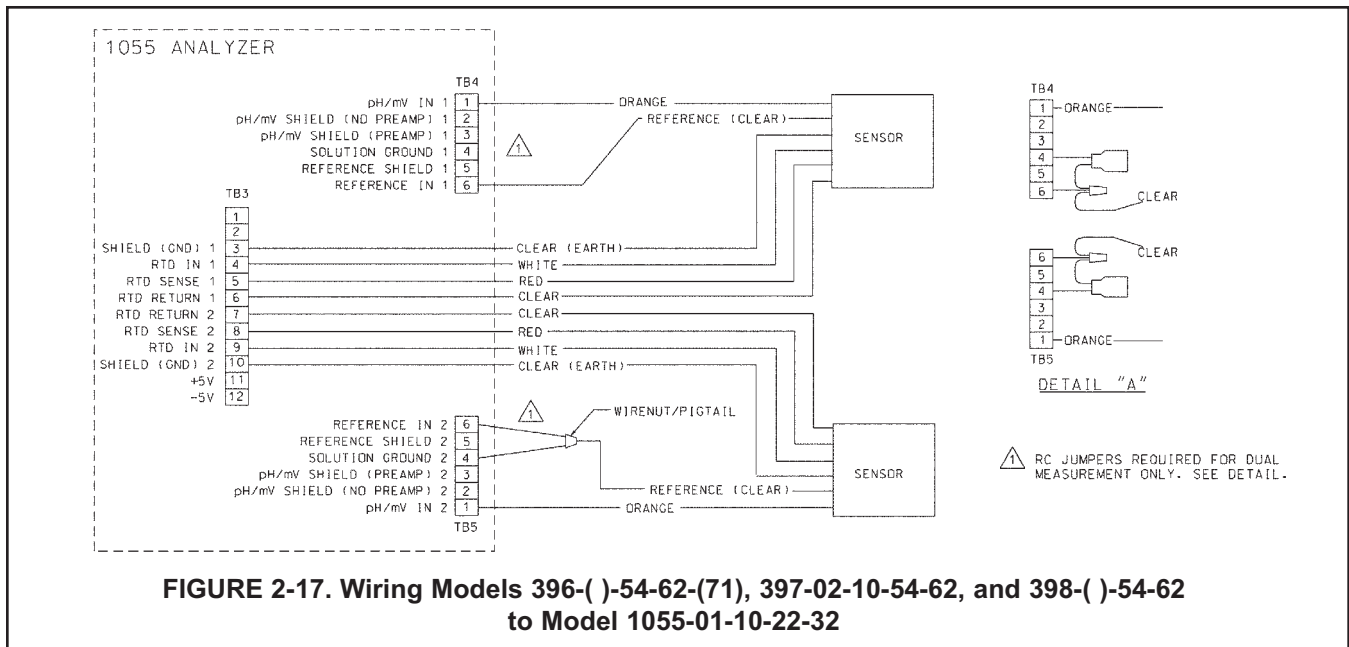
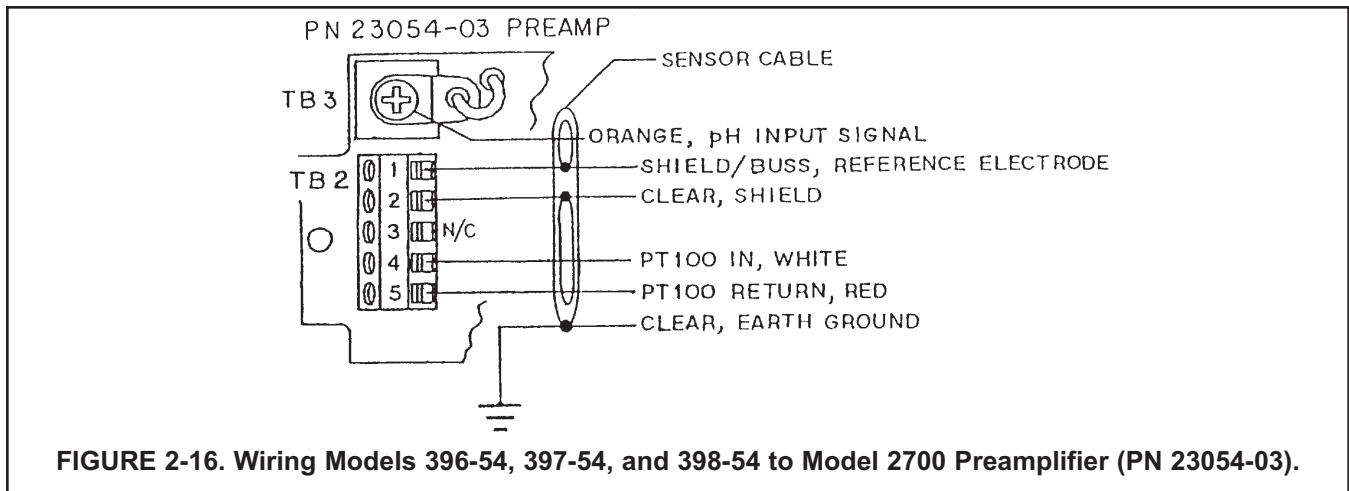

See below for wire functions for Models 396VP and 398VP. The Variopool connector cable part numbers are PN 23645-06 (with BNC) and PN 23645-07.

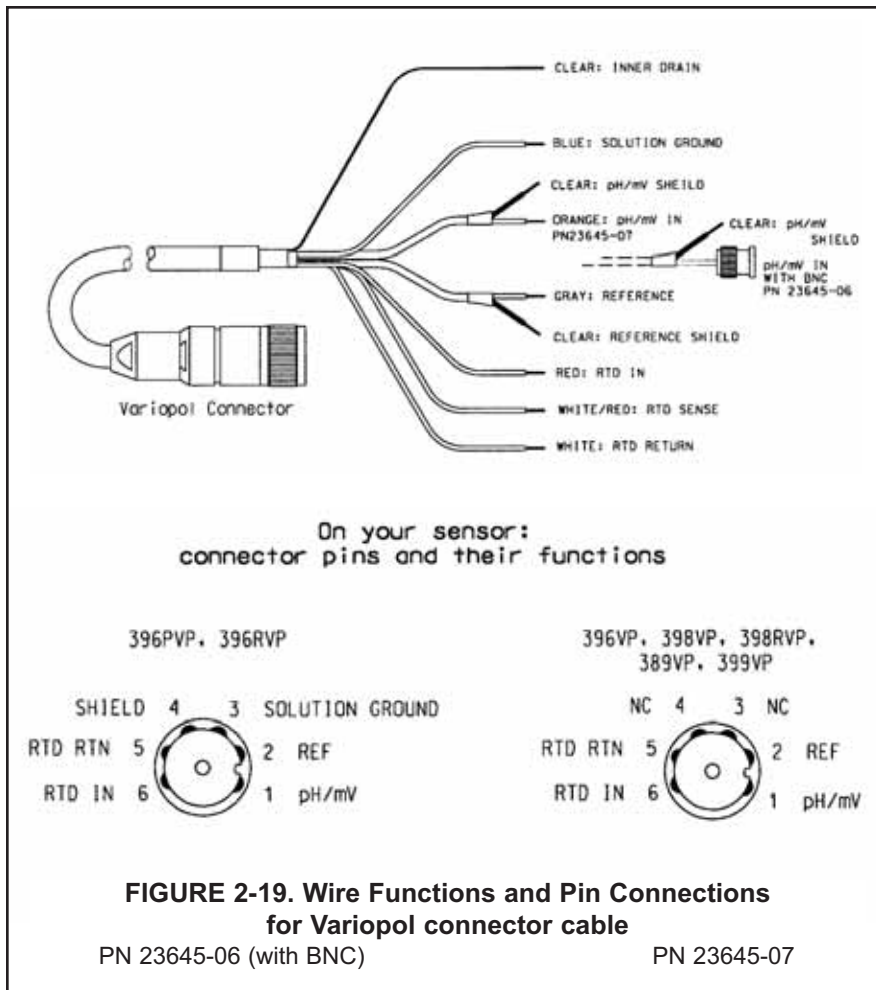
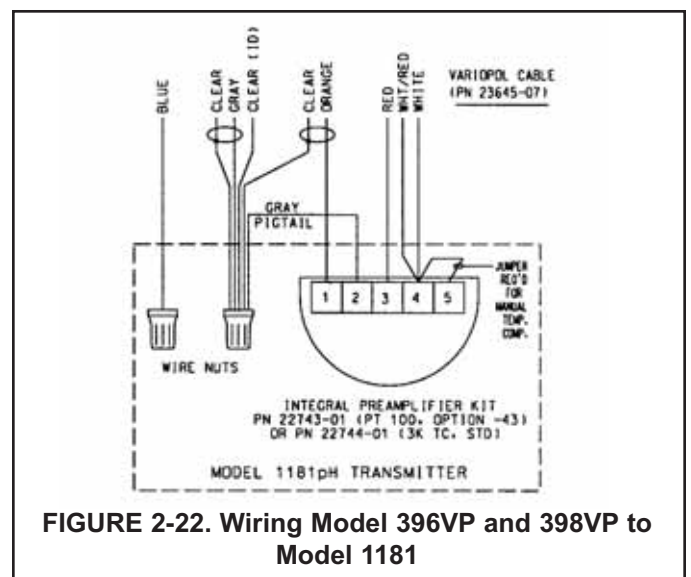
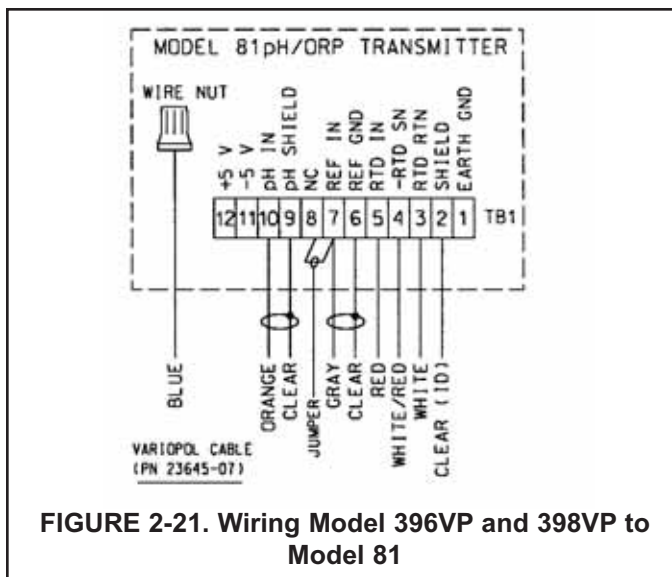
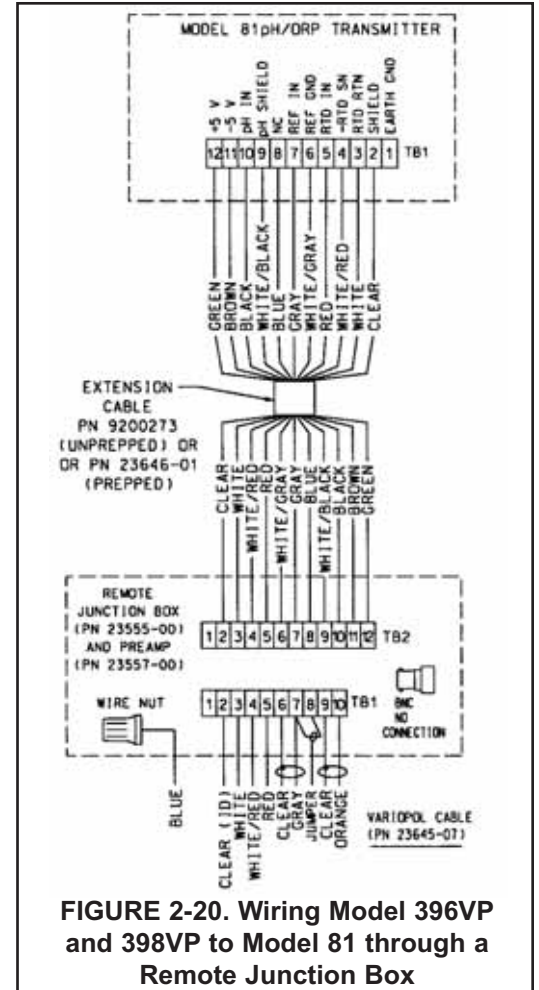

FIGURE 2-19. Wire Functions and Pin Connections for Variopool connector cable
PN 23645-06 (with BNC) PN 23645-07



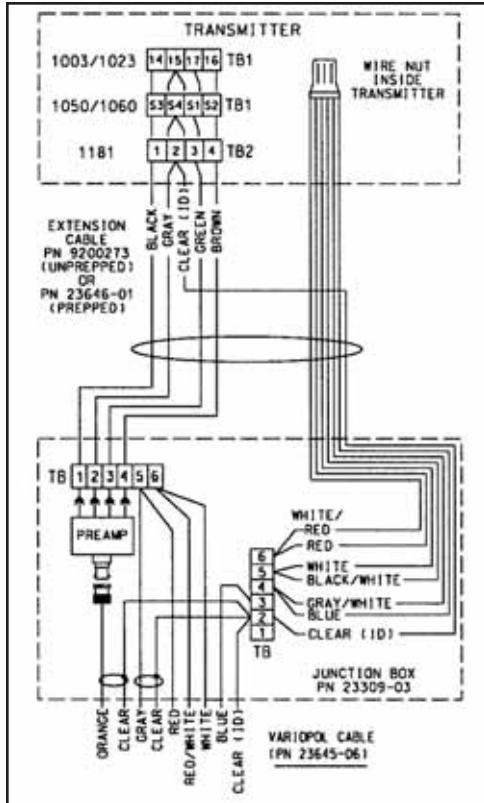

FIGURE 2-23. Wiring Model 396VP and 398VP to Model 1181, 1050/1060, and 1003/1023 through a Remote Junction Box

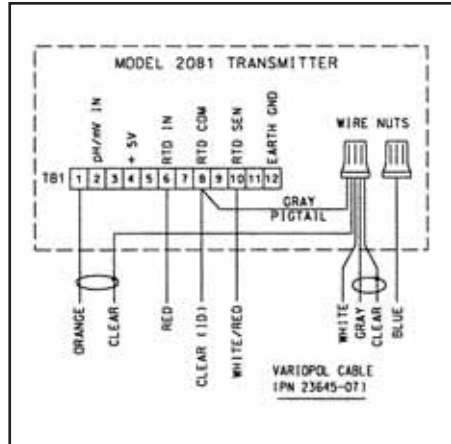

FIGURE 2-24. Wiring Model 396VP and 398VP to Model 2081

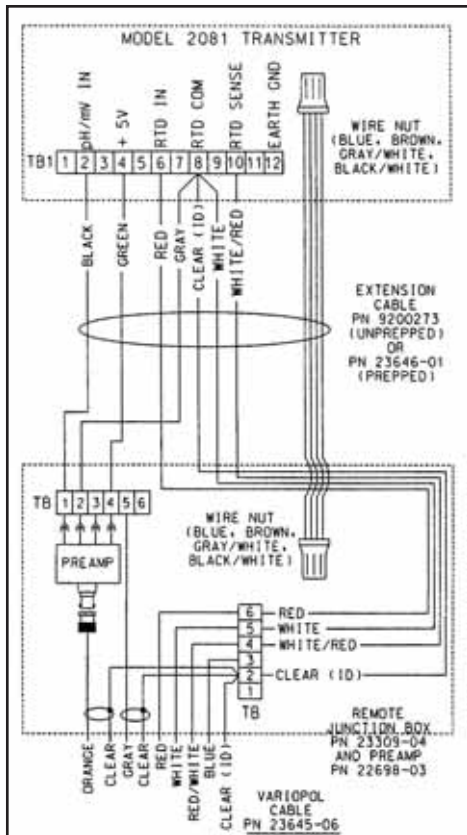

FIGURE 2-26. Wiring Model 396VP and 398VP to Model 2081 through a Remote Junction Box

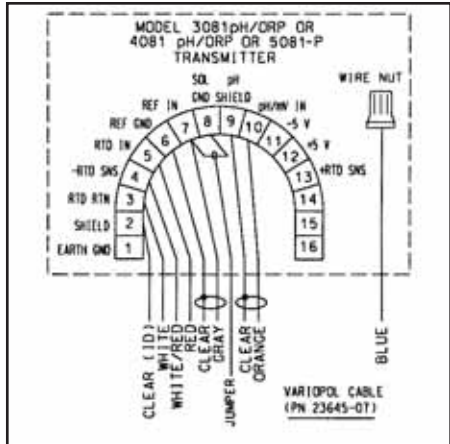

FIGURE 2-25. Wiring Model 396VP and 398VP to Model 3081 and 4081

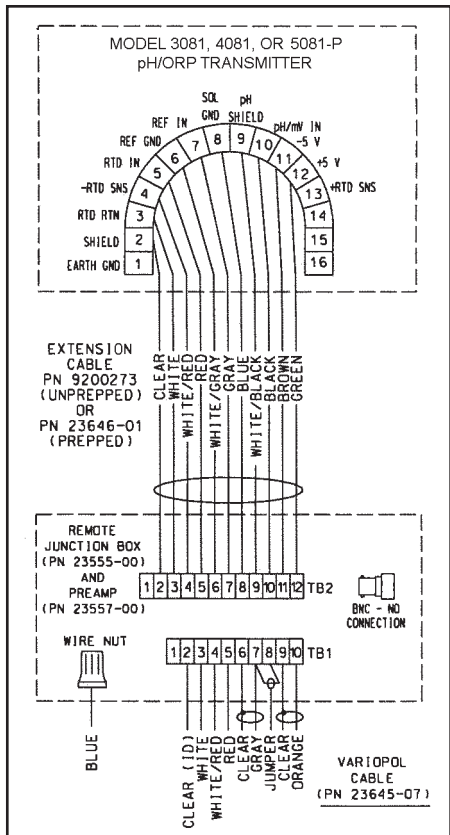

FIGURE 2-27. Wiring Model 396VP and 398VP to Model 3081, 4081, and 5081 through a Remote Junction Box

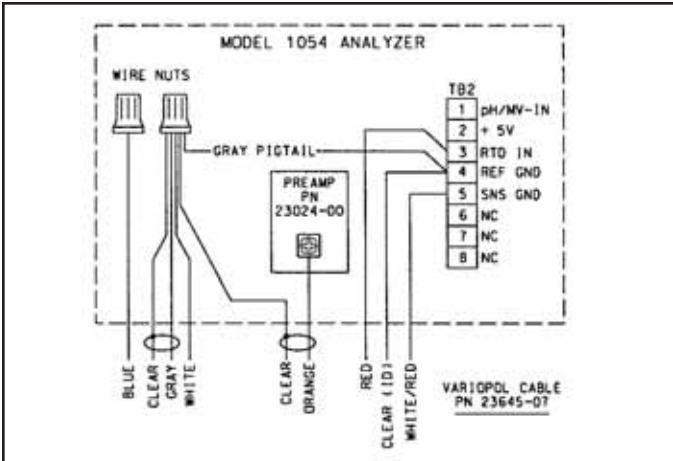

FIGURE 2-28. Wiring Model 396VP and 398VP to Model 1054

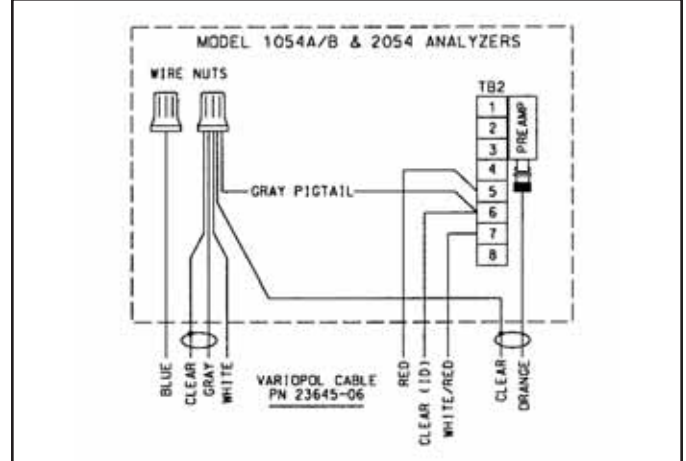

FIGURE 2-29. Wiring Model 396VP and 398VP to Models 1054A, 1054B, and 2054

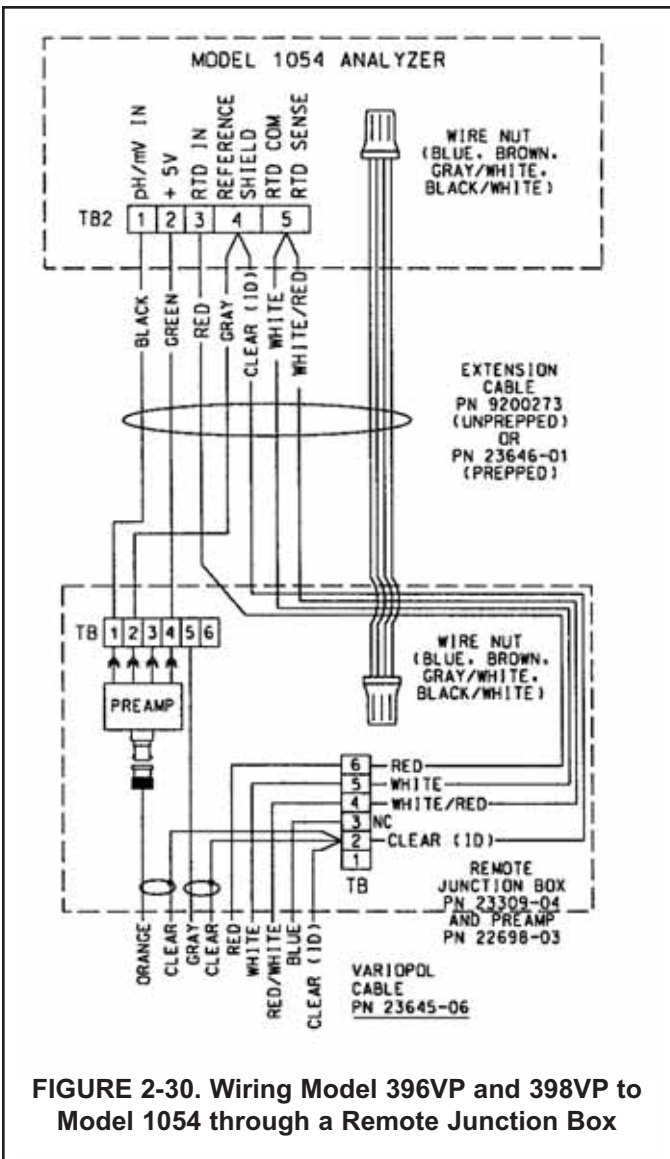

FIGURE 2-30. Wiring Model 396VP and 398VP to Model 1054 through a Remote Junction Box

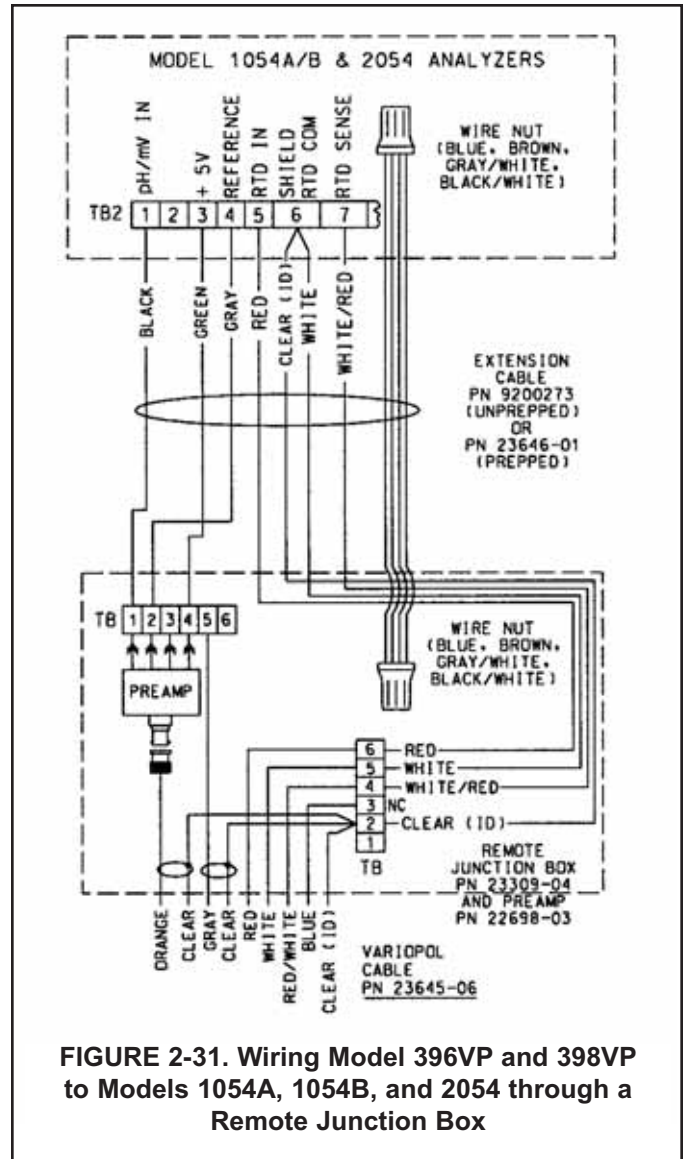

FIGURE 2-31. Wiring Model 396VP and 398VP to Models 1054A, 1054B, and 2054 through a Remote Junction Box

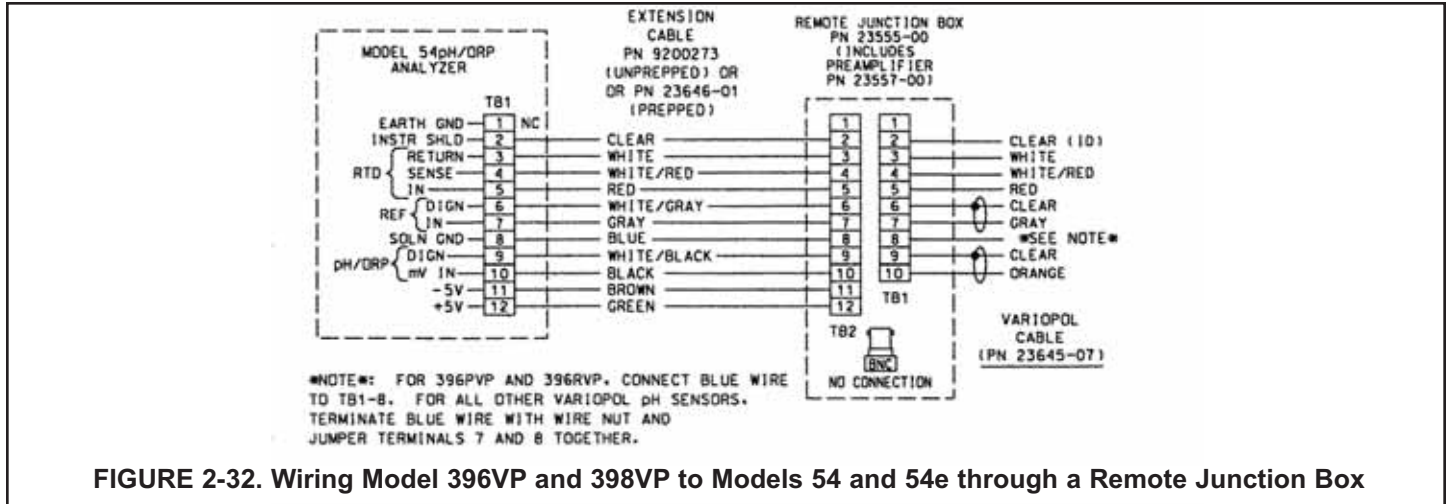

FIGURE 2-32. Wiring Model 396VP and 398VP to Models 54 and 54e through a Remote Junction Box

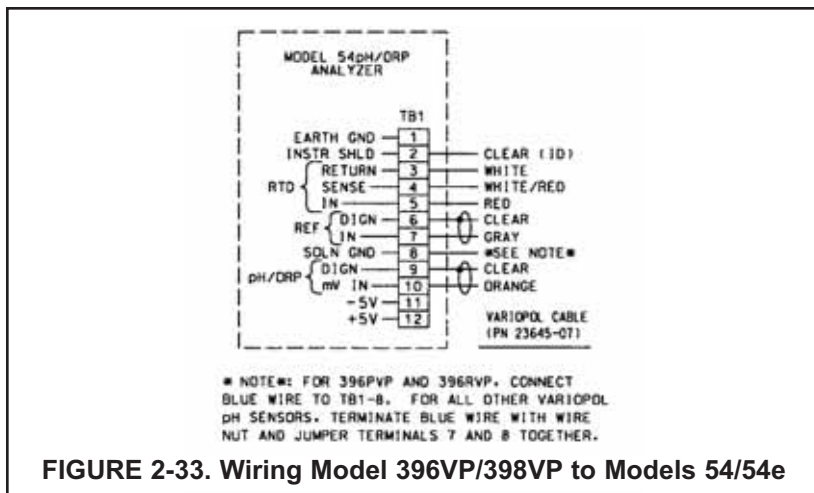

FIGURE 2-33. Wiring Model 396VP/398VP to Models 54/54e

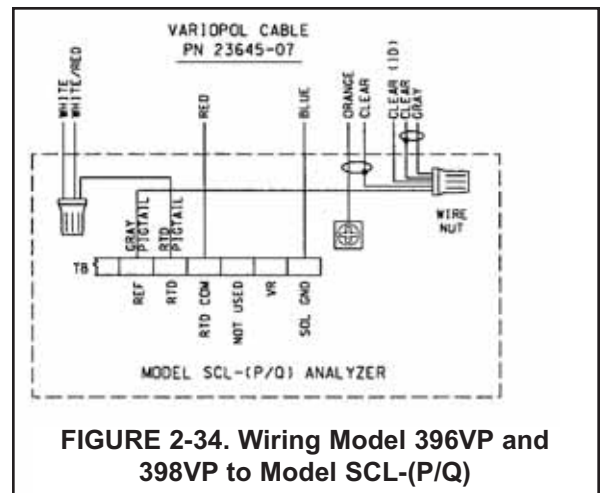

FIGURE 2-34. Wiring Model 396VP and 398VP to Model SCL-(P/Q)

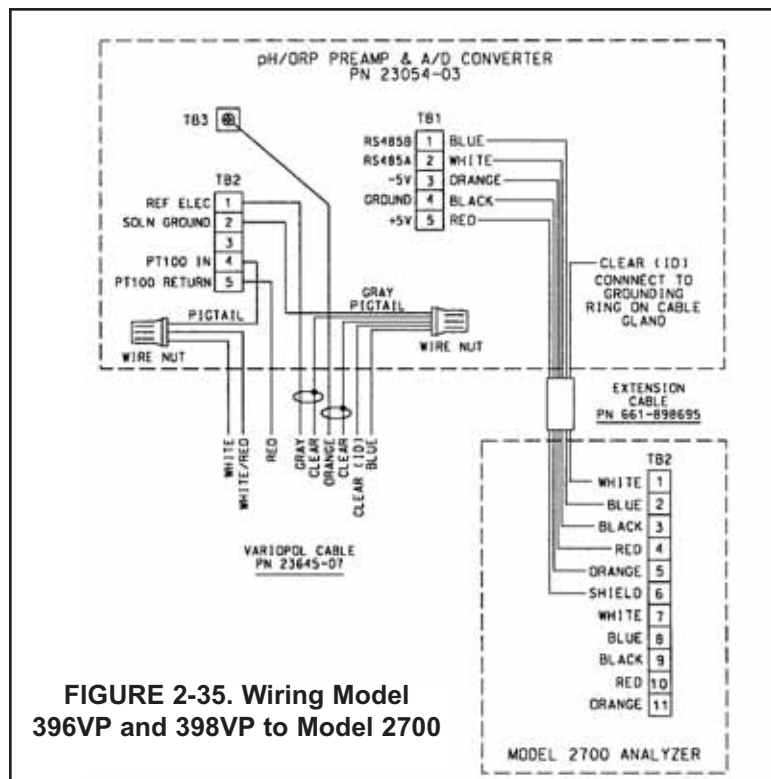

FIGURE 2-35. Wiring Model 396VP and 398VP to Model 2700

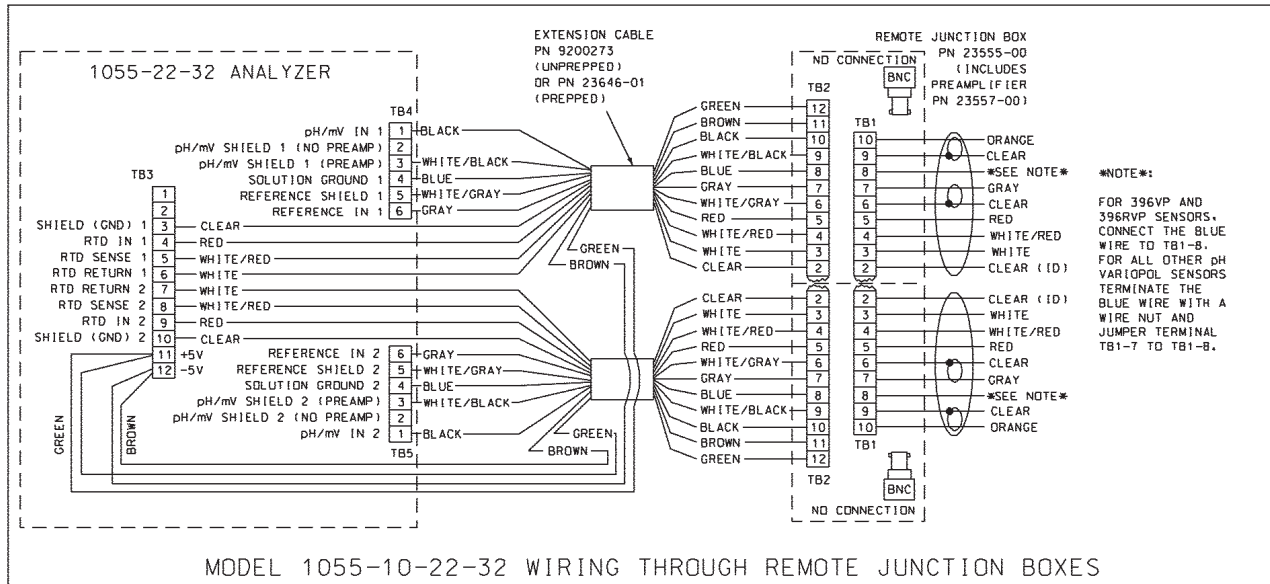
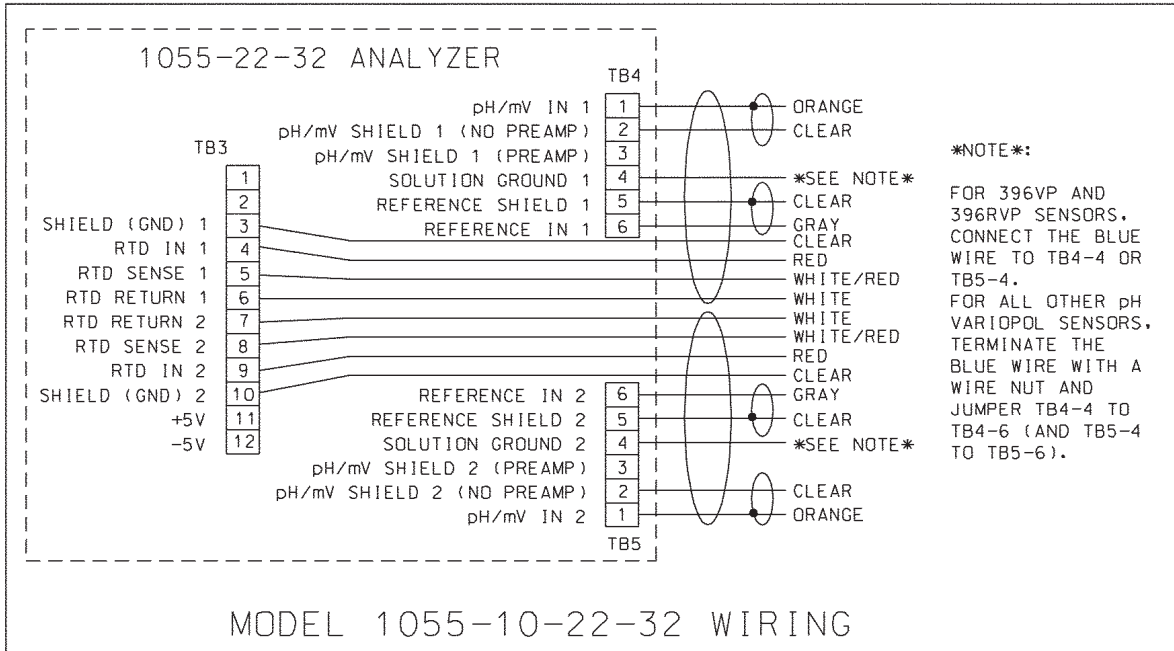

FIGURE 2-36. Wiring Model 396VP-54 to Model 1055-22-32

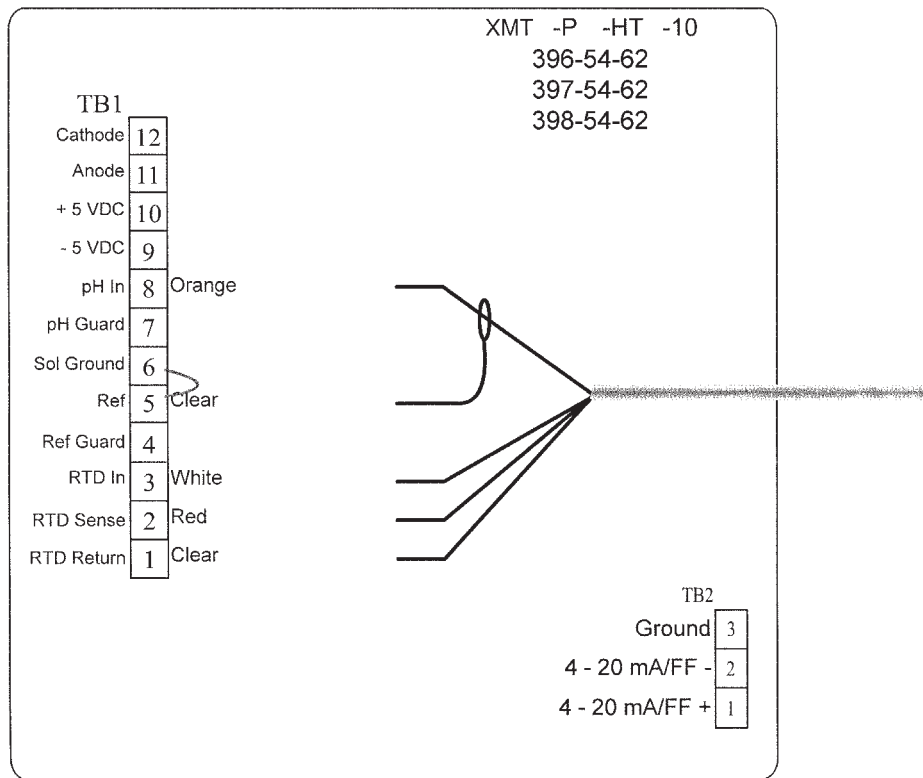

FIGURE 2-37. Wiring Models 396-54-6, 397-54-62, & 398-54-62 to Model Xmt-P-XX-10

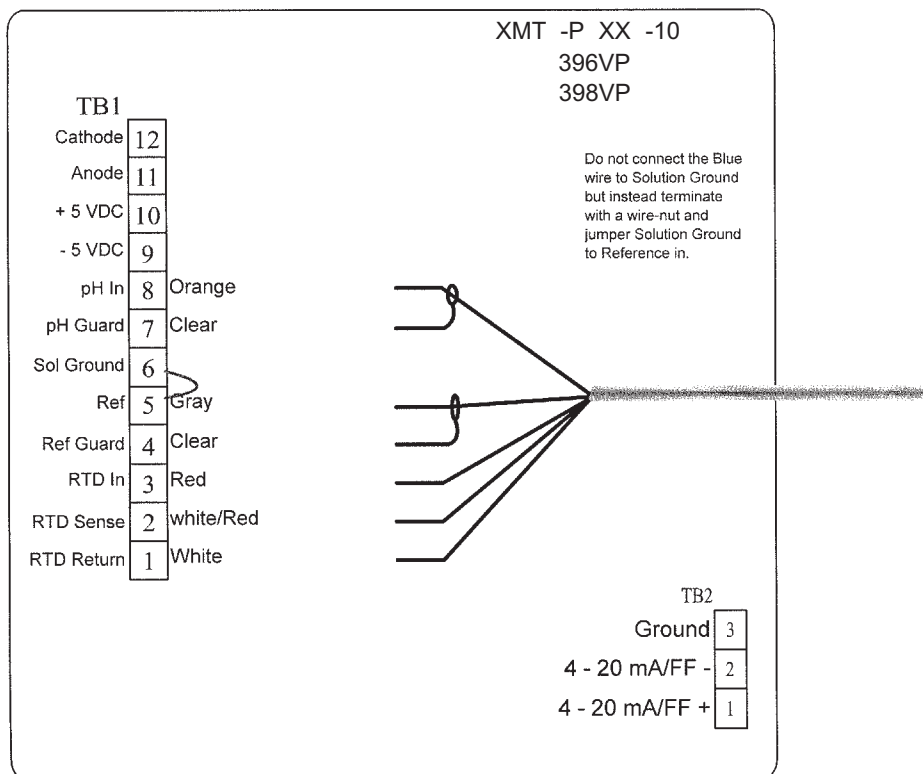

FIGURE 2-38. Wiring Models 396VP & 398VP to Model Xmt-P-XX-10

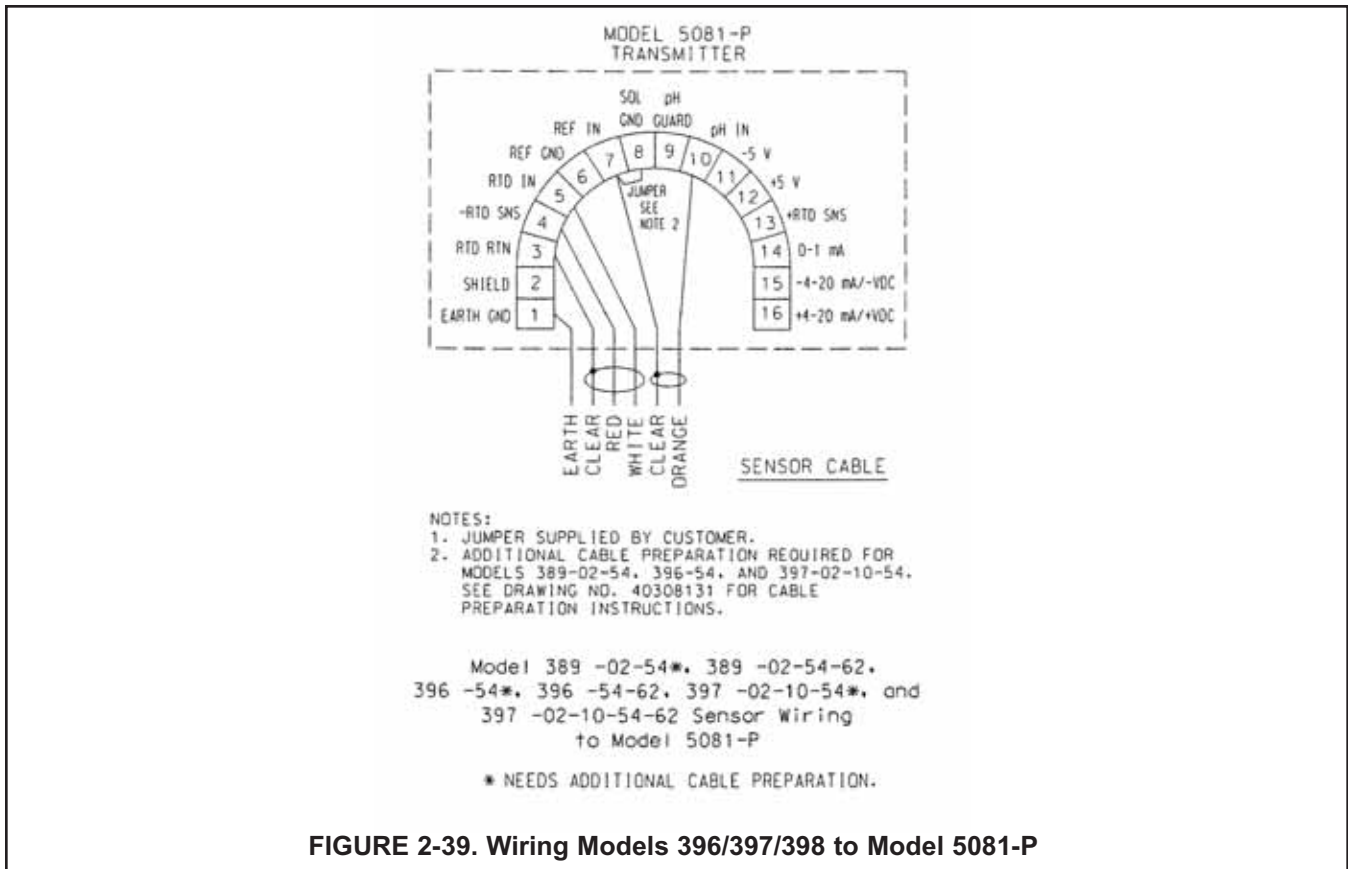

FIGURE 2-39. Wiring Models 396/397/398 to Model 5081-P

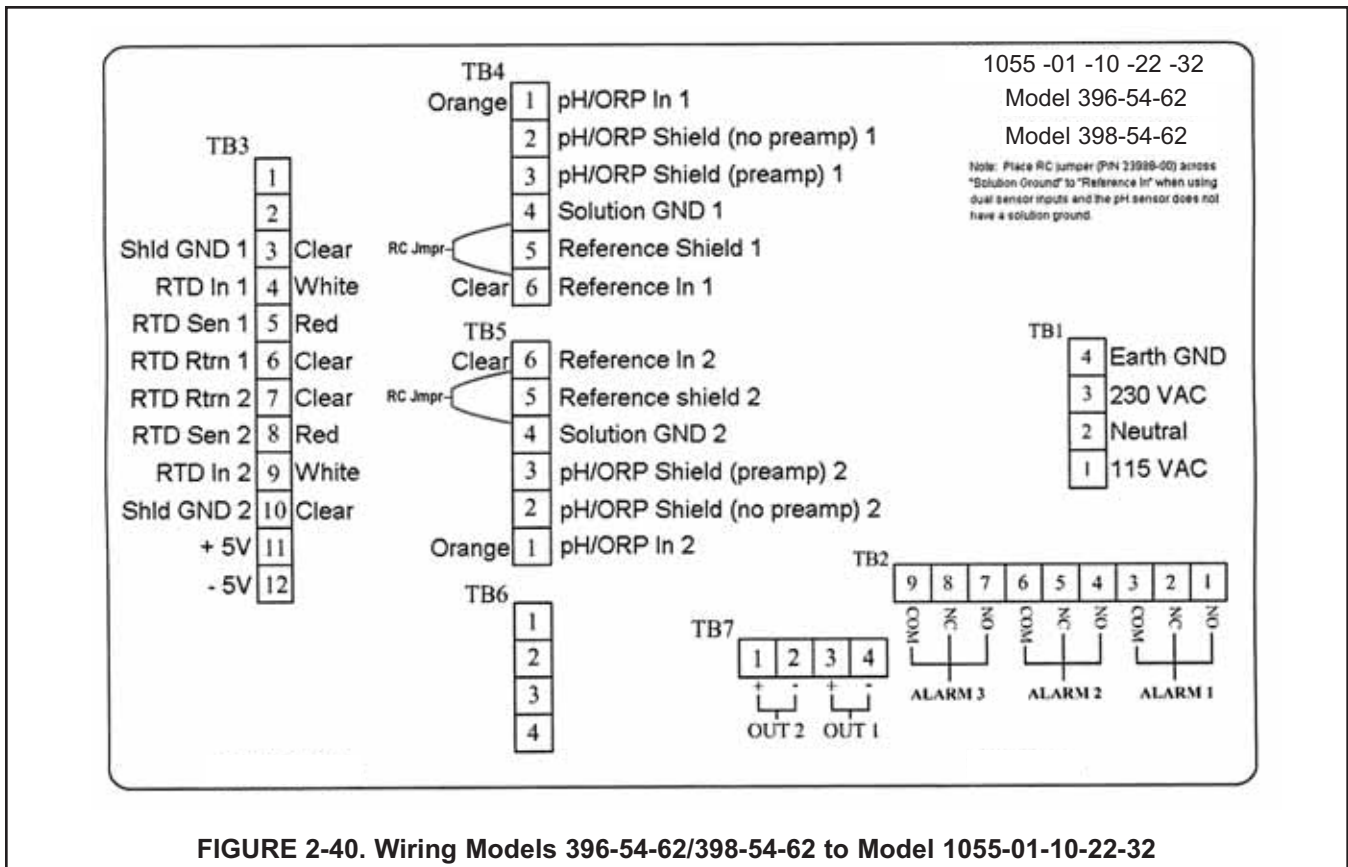

FIGURE 2-40. Wiring Models 396-54-62/398-54-62 to Model 1055-01-10-22-32

SECTION 3.0

START UP AND CALIBRATION

3.1 SENSOR PREPARATION.

Shake down the sensor to remove any air bubbles that may be present at the tip of the pH glass bulb. In most cases, the pH sensor can simply be installed as shipped and readings with an accuracy of ± 0.6 pH may be obtained. To obtain greater accuracy or to verify proper operation, the sensor must be calibrated as a loop with its compatible analyzer or transmitter.

3.2 CALIBRATION USING BUFFER SOLUTIONS OR GRAB SAMPLES.

The pH sensor-analyzer/ transmitter loop may be calibrated by submersing the sensor in a buffer solution (standard solutions of known pH values) or in a process grab sample whose pH value maybe checked by a calibrated laboratory or portable pH meter.

Please refer to the analyzer's or the transmitters respective instruction manuals for proper calibration procedures.

SECTION 4.0 MAINTENANCE

4.0 MAINTENANCE. The Model 396, 396VP, 397, 398, and 398VP Sensors are disposable type sensors and therefore require minimum maintenance. Every sensor should be kept clean and free of debris and sediment at all times. The frequency of cleaning by wiping or brushing with a soft cloth or brush is determined by the nature of the solution being measured. The sensor should be removed from the process periodically and checked in buffer solutions.

SAFETY WARNING	
<p>SENSOR IS IN PRESSURIZED SYSTEM! May cause spray and bodily injury. Before removing sensor, be absolutely certain that the process pressure is reduced to 0 psig and the process temperature is lowered to a safe level.</p>	

If the sensor will not calibrate, refer to your analyzer/transmitter instruction manual for proper test procedures. If it is determined that the sensor has failed, it should be discarded and replaced.

4.1 ELECTRODE CLEANING. If the electrode is coated or dirty, clean as follows:

1. Remove the sensor from process.

SAFETY WARNING	
<p>SENSOR IS IN PRESSURIZED SYSTEM may cause spray and bodily injury. Before removing sensor, be absolutely certain that the process pressure is reduced to 0 psig and the process temperature is lowered to a safe level.</p>	

2. Wipe the glass bulb with a soft, clean, lint free cloth or tissue. If this does not remove the dirt or coating, go to Step 3. (Detergents clean oil and grease; acids remove scale.)
3. Wash the glass bulb in a strong detergent solution and rinse it in clean water. If this does not clean the glass bulb, go to Step 4.

CAUTION	
<p>The solution used during the following check is an acid and should be handled with care. Follow the directions of the acid manufacturer. Wear the proper protective equipment. Do not let the solution come in contact with skin or clothing. If contact with skin is made, immediately rinse with clean water.</p>	

4. Wash the glass bulb in a dilute 5% hydrochloric acid solution and rinse with clean water. Soaking the sensor overnight in the acid solution can improve cleaning action.

NOTE

Erroneous pH results may occur immediately after acid soak, due to reference junction potential build-up.

Replace the sensor if cleaning does not restore sensor operation.

4.2 AUTOMATIC TEMPERATURE COMPENSATOR.

The temperature compensator element is temperature sensitive and can be checked with an ohmmeter. Resistance increases with temperature.

The 3K element will read 3000 ohms ±1% at 25°C (77°F) and a Pt-100 will read 110 ohms. Resistance varies with temperature for a 3K and Pt-100 element and can be determined according to Table 4-2 or the following formula:

$$R_T = R_0 [1 + R_1 (T - 20)]$$

Where R_T = Resistance
 T = Temperature in °C

Refer to Table 4-1 for R_0 and R_1 values

TABLE 4-1. R_0 and R_1 Values for Temperature Compensation Elements

Temperature Compensation Element	R_0	R_1
3K	2934	.0045
PT-100	107.7	.00385

TABLE 4-2. Temperature vs Resistance of Auto T.C. Elements

Temperature °C	Resistance (Ohms) ±1%	
	3K	PT-100
0	2670	100.0
10	2802	103.8
20	2934	107.7
25	3000	109.6
30	3066	111.5
40	3198	115.4
50	3330	119.2
60	3462	123.1
70	3594	126.9
80	3726	130.8
90	3858	134.6
100	3990	138.5

SECTION 5.0 TROUBLESHOOTING

TABLE 5-1. Troubleshooting

Trouble	Probable Cause	Remedy
Meter reads off scale. (Display reads overrange.)	T.C. element shorted.	Check T.C. element as instructed in Section 4.2 and replace sensor if defective.
	Sensor not in process or sample stream is low.	Make sure sensor is in process with sufficient sample stream (refer to Section 2.0 for installation details).
	Open glass electrode.	Replace sensor.
	Reference element open - no contact.	Replace sensor.
Display reads between 3 and 6 pH regardless of actual pH of solution or sample.	Electrode cracked.	Replace sensor.
Meter or display indication swings or jumps widely in AUTO T.C. Mode.	T.C. element shorted.	Check T.C. element as instructed in Section 4.2 and replace sensor if defective.
Span between buffers extremely short in AUTO T.C. Mode.	T.C. element open.	Check T.C. element as instructed in Section 4.2 and replace sensor if defective.
Sluggish or slow meter indication for real changes in pH level.	Electrode coated.	Clean sensor as instructed in Sections 4.1 Replace sensor if cracked.
	Electrode at end of life.	Replace sensor.
Transmitter cannot be standardized.	Electrode coated or cracked.	Clean sensor as instructed in Sections 4.1. Replace sensor if cracked.
Transmitter short spans between two different buffer values.	Electrode at end of life, due to old glass or high temperature exposure.	Replace sensor.
	Coated glass.	Clean sensor as instructed in Section 4.1. Replace sensor if cracked.

SECTION 6.0 RETURN OF MATERIAL

6.1 GENERAL.

To expedite the repair and return of instruments, proper communication between the customer and the factory is important. Before returning a product for repair, call 1-949-757-8500 for a Return Materials Authorization (RMA) number.

6.2 WARRANTY REPAIR.

The following is the procedure for returning instruments still under warranty:

1. Call Rosemount Analytical for authorization.
2. To verify warranty, supply the factory sales order number or the original purchase order number. In the case of individual parts or sub-assemblies, the serial number on the unit must be supplied.
3. Carefully package the materials and enclose your "Letter of Transmittal" (see Warranty). If possible, pack the materials in the same manner as they were received.
4. Send the package prepaid to:

Rosemount Analytical Inc., Uniloc Division
 Uniloc Division
 2400 Barranca Parkway
 Irvine, CA 92606

Attn: Factory Repair

RMA No. _____

Mark the package: Returned for Repair

Model No. _____

6.3 NON-WARRANTY REPAIR.

The following is the procedure for returning for repair instruments that are no longer under warranty:

1. Call Rosemount Analytical for authorization.
2. Supply the purchase order number, and make sure to provide the name and telephone number of the individual to be contacted should additional information be needed.
3. Do Steps 3 and 4 of Section 6.2.

NOTE

Consult the factory for additional information regarding service or repair.

WARRANTY

Seller warrants that the firmware will execute the programming instructions provided by Seller, and that the Goods manufactured or Services provided by Seller will be free from defects in materials or workmanship under normal use and care until the expiration of the applicable warranty period. Goods are warranted for twelve (12) months from the date of initial installation or eighteen (18) months from the date of shipment by Seller, whichever period expires first. **Consumables, such as glass electrodes, membranes, liquid junctions, electrolyte, o-rings, catalytic beads, etc., and Services are warranted for a period of 90 days from the date of shipment or provision.**

Products purchased by Seller from a third party for resale to Buyer ("Resale Products") shall carry only the warranty extended by the original manufacturer. Buyer agrees that Seller has no liability for Resale Products beyond making a reasonable commercial effort to arrange for procurement and shipping of the Resale Products.

If Buyer discovers any warranty defects and notifies Seller thereof in writing during the applicable warranty period, Seller shall, at its option, promptly correct any errors that are found by Seller in the firmware or Services, or repair or replace F.O.B. point of manufacture that portion of the Goods or firmware found by Seller to be defective, or refund the purchase price of the defective portion of the Goods/Services.

All replacements or repairs necessitated by inadequate maintenance, normal wear and usage, unsuitable power sources, unsuitable environmental conditions, accident, misuse, improper installation, modification, repair, storage or handling, or any other cause not the fault of Seller are not covered by this limited warranty, and shall be at Buyer's expense. Seller shall not be obligated to pay any costs or charges incurred by Buyer or any other party except as may be agreed upon in writing in advance by an authorized Seller representative. All costs of dismantling, reinstallation and freight and the time and expenses of Seller's personnel for site travel and diagnosis under this warranty clause shall be borne by Buyer unless accepted in writing by Seller.

Goods repaired and parts replaced during the warranty period shall be in warranty for the remainder of the original warranty period or ninety (90) days, whichever is longer. This limited warranty is the only warranty made by Seller and can be amended only in a writing signed by an authorized representative of Seller. Except as otherwise expressly provided in the Agreement, THERE ARE NO REPRESENTATIONS OR WARRANTIES OF ANY KIND, EXPRESS OR IMPLIED, AS TO MERCHANTABILITY, FITNESS FOR PARTICULAR PURPOSE, OR ANY OTHER MATTER WITH RESPECT TO ANY OF THE GOODS OR SERVICES.

RETURN OF MATERIAL

Material returned for repair, whether in or out of warranty, should be shipped prepaid to:

**Emerson Process Management
Liquid Division
2400 Barranca Parkway
Irvine, CA 92606**

The shipping container should be marked:

Return for Repair

Model _____

The returned material should be accompanied by a letter of transmittal which should include the following information (make a copy of the "Return of Materials Request" found on the last page of the Manual and provide the following thereon):

1. Location type of service, and length of time of service of the device.
2. Description of the faulty operation of the device and the circumstances of the failure.
3. Name and telephone number of the person to contact if there are questions about the returned material.
4. Statement as to whether warranty or non-warranty service is requested.
5. Complete shipping instructions for return of the material.

Adherence to these procedures will expedite handling of the returned material and will prevent unnecessary additional charges for inspection and testing to determine the problem with the device.

If the material is returned for out-of-warranty repairs, a purchase order for repairs should be enclosed.



*The right people,
the right answers,
right now.*

**ROSEMOUNT ANALYTICAL
CUSTOMER SUPPORT CENTER
1-800-854-8257**



Credit Cards for U.S. Purchases Only.



ON-LINE ORDERING NOW AVAILABLE ON OUR WEB SITE
<http://www.raihome.com>

Specifications subject to change without notice.

Emerson Process Management

2400 Barranca Parkway
Irvine, CA 92606 USA
Tel: (949) 757-8500
Fax: (949) 474-7250

<http://www.raihome.com>

