

912N Series Pressure Regulators

Introduction

The 912N Series direct-operated, spring-loaded regulators are used in a variety of service and industrial applications. These regulators have limited-capacity internal relief across the diaphragm (see Figure 2) to help minimize overpressure. Any outlet pressure above the start-to-discharge point of the non-adjustable relief valve spring moves the diaphragm off the relief valve seat, allowing excess pressure to bleed out through the screened spring case vent. Inlet pressure capabilities are the same for all regulators described in this bulletin. However, outlet pressure ranges vary according to construction (see Table 1).

Features

- **Accurate and Sensitive Control**—Disk/lever assembly is attached to a roller-style pivot for smoother action. Handwheel construction is available for adjustment of the pressure setting.
- **Versatility**—These regulators are suitable for a variety of gaseous fluids, including natural gas, propane, and air. They are often used to supply loading pressure to other units.
- **Weather and Insect Protection**—“Drip lip” vent helps resist blockage during icing conditions. When the regulator is installed with the vent pointing down, any ice that builds up forms a protective sheath that helps keep the opening unobstructed. The vent screen helps prevent foreign material from entering the spring case and clogging or otherwise hindering regulator operation.
- **Easy Maintenance**—Diaphragm and disk/lever assembly can be replaced without removing the regulator from the pipeline.

Principle of Operation

Refer to Figure 2. When downstream demand decreases, the pressure under the diaphragm increases. This pressure overcomes the regulator setting (which is set by a spring). Through the action of the pusher post assembly, the valve disk moves closer to the orifice and reduces gas flow. If demand downstream increases, pressure under the diaphragm decreases. Spring force pushes the pusher post assembly



P1024

Figure 1. 912N Series Regulator

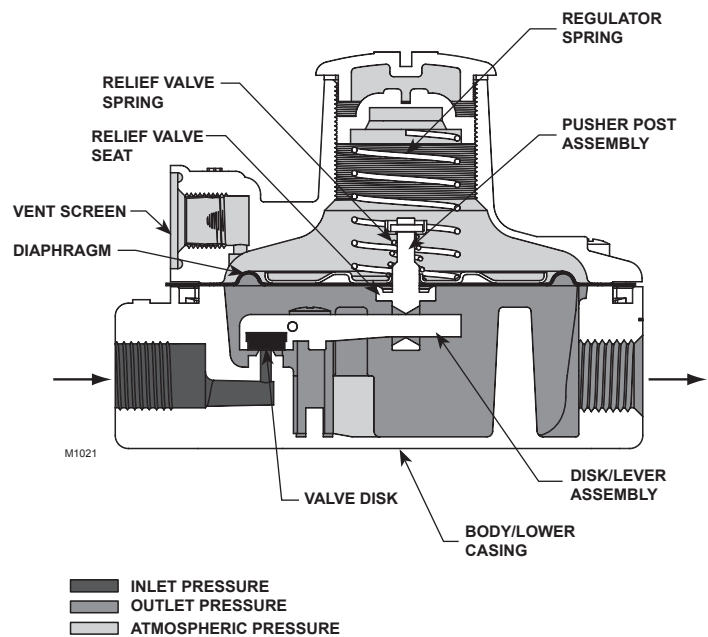

Figure 2. 912N Series Operational Schematic (Standard Spring Case Vent Shown)

Bulletin 71.1:912N

Specifications

Available Constructions

See Table 1

Body Sizes and End Connection Styles

Inlet: 1/4 NPT

Outlet: 1/4 or 3/8 NPT

Maximum Allowable Inlet Pressure⁽¹⁾

250 psig (17,2 bar)

Outlet Pressure Ranges⁽¹⁾

See Table 1

Maximum Allowable Outlet Pressure⁽¹⁾

Emergency Outlet Pressure: 20 psig (1,4 bar)

Recommended Outlet Pressure to Avoid Internal

Part Damage: 3 psid (0,21 bar differential) above outlet pressure setting; provide external relief if start-to-discharge point exceeds 3 psid (0,21 bar differential) (see Table 1).

Body Port Diameter

0.073 or 0.094-inch (1,9 or 2,4 mm)

Wide-Open C_g for Relief Sizing

4

Typical Regulating Capacities

See Tables 2 and 3

Internal Relief Performance

Approximate Internal Relief Valve

Start-to-Discharge Point: See Table 1

Capacity: Adequate only for relieving minor buildup situations such as those caused by chips or dirt blocking the seat partly open; for major malfunctions, external relief is required according to the Overpressure Protection section

Temperature Capabilities⁽¹⁾

-20° to 160°F (-29° to 71°C)

Pressure Registration

Internal

Spring Case Vent

Standard Construction: 1/8 NPT tapped with removable screen

Standard Location

Constructions Without Handwheel: Over body outlet

Handwheel Constructions: Over body inlet

Approximate Weight

1.3 pounds (0,6 kg)

Construction Materials

Body/Lower Casing: Zinc

Spring Case: Zinc

Spring Case Bolting: Plated carbon steel

Disk/Lever Assembly: Fluorocarbon (FKM) disk with zinc lever, stainless steel lever pin and rod, and plated carbon steel lever screws

Diaphragm: Nitrile (NBR)/Nylon (PA)

Diaphragm Plate: Plated steel

Spring Seat: Plated steel

Control and Relief Valve Spring: Plated steel spring wire, except stainless steel spring wire for control spring 1L507937022

Closing Spring (Optional Handwheel

Constructions Only): Stainless steel spring wire

Relief Valve Assembly: Brass and zinc

Closing Cap and Adjusting Screw

(Constructions Without Handwheel): Plastic

Closing Cap and Adjusting Screw

Assembly (Optional Handwheel Constructions Only): Brass, zinc, and steel

Closing Cap Gasket: Composition

Vent Screen: 304 Stainless Steel

1. The pressure/temperature limits in this Bulletin or any applicable standard limitation should not be exceeded.

downward and the valve disk moves away from the orifice. 912N Series regulators include an internal relief valve for overpressure protection.

Overpressure Protection

The 912N Series have outlet pressure ratings lower than their inlet pressure ratings. Although the internal relief valve provides very limited downstream overpressure protection, complete downstream protection is needed if the actual inlet pressure exceeds the outlet pressure rating.

Overpressuring any portion of these regulators may cause leakage, damage to regulator parts, or personal injury due to bursting of pressure-containing parts or explosion of accumulated gas. Provide appropriate overpressure protection devices to ensure that none of the limits found in the Specifications section or Table 1 will be exceeded.

Regulator operation with normal operating limits does not preclude the possibility of damage from external sources or from debris in the gas line. A regulator should be inspected for damage after any overpressure condition.

Installation

912N Series regulators may be installed in any position; however, the spring case vent should be pointed down on outside installations. If gas escaping through the internal relief valve could constitute a hazard, the spring case vent should be piped to a location where escaping gas will not be hazardous. If the vent will be piped to another location, obstruction-free tubing should be used and a screened vent should be installed on the end of the vent pipe. On all installations, the vent or end of the vent pipe must

Table 1. Outlet Pressure Range Data

AVAILABLE CONSTRUCTION	OUTLET PRESSURE RANGE	APPROXIMATE POINT ABOVE OUTLET PRESSURE SETTING AT WHICH INTERNAL RELIEF STARTS TO DISCHARGE	CONTROL SPRING SELECTION			
			Part Number	Color Code	Spring Free Length, Inch (mm)	Spring Wire Diameter, Inch (mm)
912N Series without handwheel	3 to 7-inches w.c. (7 to 17 mbar)	5 to 21-inches w.c. (12 to 52 mbar)	1B784327222	Red	1.09 (27,7)	0.035 (0,89)
	5 to 10-inches w.c. (12 to 25 mbar)	8 to 30-inches w.c. (20 to 75 mbar)	1B784427222	Orange	1.37 (34,8)	0.037 (0,94)
	9.25 to 13-inches w.c. (23 to 32 mbar)	16 to 39-inches w.c. (40 to 97 mbar)	1L507937022	Unpainted	1.78 (45,2)	0.038 (0,97)
	12 to 24-inches w.c. (30 to 60 mbar)	17-inches w.c. to 3 psig (42 mbar to 0,21 bar)	1B784527222	Blue	1.34 (34,0)	0.047 (1,19)
912N Series with handwheel	0.5 to 2.7 psig (0,03 to 0,18 bar)	0.70 to 6.80 psig (0,05 to 0,47 bar)	1B784627222	Yellow	1.19 (30,2)	0.075 (1,91)
	2.7 to 5 psig (0,18 to 0,34 bar)	3.80 to 12.5 psig (0,26 to 0,86 bar)	1B784727222	Green	1.31 (33,3)	0.080 (2,03)
912N Series with handwheel	8 to 24-inches w.c. (20 to 60 mbar)	30.3 to 35.4-inches w.c. (75 to 88 mbar)	1B784527222	Blue	1.34 (34,0)	0.047 (1,19)
	2.7 to 5 psig (0,18 to 0,34 bar)	5.4 to 6.7 psig (0,37 to 0,46 bar)	1B784727222	Green	1.31 (33,3)	0.080 (2,03)

1. Internal Relief Performance is only adequate for relieving minor buildup situations. External relief is required if start-to-discharge point exceeds 3 psid (0,21 bar differential).

Table 2. Capacities for Type 912N Regulators without Handwheel (Body Size 1/4 x 3/8 NPT)

OUTLET PRESSURE SETTING	OUTLET PRESSURE RANGE	SPRING PART NUMBER	OFFSET	ORIFICE SIZE, INCH (mm)	CAPACITY IN SCFH (Nm ³ /h) OF 0.6 SPECIFIC GRAVITY NATURAL GAS									
					Inlet Pressure, Psig (bar)									
					5 (0,34)	10 (0,69)	25 (1,7)	50 (3,4)	75 (5,2)	100 (6,9)	150 (10,3)	200 (13,8)	250 (17,2)	
5-inches w.c. (12 mbar)	3 to 7-inches w.c. (7 to 17 mbar)	1B784327222	1-inch w.c. (2 mbar)	0.073 (1,9)	53 (1,42)	73 (1,96)	136 (3,65)	199 (5,33)	----	----	----	----	----	----
7-inches w.c. (17 mbar)	5 to 10-inches w.c. (12 to 25 mbar)	1B784427222	1-inch w.c. (2 mbar)		----	72 (1,93)	122 (3,27)	171 (4,58)	187 (5,01)	222 (5,95)	222 (5,95)	232 (6,22)	----	
11-inches w.c. (27 mbar)	9.25 to 13-inches w.c. (23 to 32 mbar)	1L507937022	1-inch w.c. (2 mbar)		----	61 (1,64)	100 (2,68)	144 (3,86)	163 (4,37)	180 (4,82)	210 (5,63)	234 (6,27)	259 (6,94)	
20-inches w.c. (50 mbar)	12 to 24-inches w.c. (30 to 60 mbar)	1B784527222	2-inches w.c. (5 mbar)		----	58 (1,55)	95 (2,55)	137 (3,67)	163 (4,37)	189 (5,07)	243 (6,51)	303 (8,12)	315 (8,44)	
1 psig (69 mbar)	0.5 to 2.7 psig (0,03 to 0,18 bar)	1B784627222	10%	0.094 (2,4)	----	51 (1,37)	63 (1,69)	83 (2,22)	99 (2,65)	105 (2,81)	148 (3,97)	204 (5,47)	236 (6,33)	
			20%		----	70 (1,88)	100 (2,68)	140 (3,75)	177 (4,74)	201 (5,39)	302 (8,09)	377 (10,1)	440 (11,8)	
2 psig (138 mbar)	0.5 to 2.7 psig (0,03 to 0,18 bar)	1B784627222	10%		----	62 (1,66)	91 (2,44)	120 (3,22)	155 (4,15)	178 (4,77)	249 (6,67)	304 (8,15)	358 (9,59)	
			20%		----	85 (2,28)	146 (3,91)	220 (5,90)	300 (8,04)	348 (9,33)	480 (12,9)	576 (15,4)	683 (18,3)	
5 psig (345 mbar)	2.7 to 5 psig (0,18 to 0,34 bar)	1B784727222	10%		----	68 (1,82)	107 (2,87)	149 (3,99)	207 (5,55)	329 (8,82)	329 (8,82)	425 (11,4)	618 (16,6)	
			20%		----	94 (2,52)	169 (4,53)	283 (7,58)	386 (10,3)	486 (13,0)	711 (19,1)	860 (23,0)	1030 (27,6)	

---- Not recommended for the given pressure range.

Table 3. Capacities for Type 912N Regulators with Handwheel (Body Size 1/4 x 3/8 NPT)

OUTLET PRESSURE SETTING	OUTLET PRESSURE RANGE	SPRING PART NUMBER	OFFSET	ORIFICE SIZE, INCH (mm)	CAPACITY IN SCFH (Nm ³ /h) OF 0.6 SPECIFIC GRAVITY NATURAL GAS								
					Inlet Pressure, Psig (bar)								
					5 (0,34)	10 (0,69)	25 (1,7)	50 (3,4)	75 (5,2)	100 (6,9)	150 (10,3)	200 (13,8)	250 (17,2)
14-inches w.c. (35 mbar)	8 to 24-inches w.c. (20 to 60 mbar)	1B784527222	2-inches w.c. (5 mbar)	0.094 (2,4)	70 (1,88)	96 (2,57)	121 (3,24)	129 (3,46)	143 (3,83)	156 (4,18)	156 (4,18)	190 (5,09)	212 (5,68)
3 psig (207 mbar)	2.7 to 5 psig (0,18 to 0,34 bar)	1B784727222	10%		----	92 (2,47)	153 (4,10)	261 (7,00)	354 (9,49)	459 (12,3)	587 (15,7)	716 (19,2)	731 (19,6)

---- Not recommended for the given pressure range.

Bulletin 71.1:912N

be protected from corrosive chemicals, debris, weather, condensation, or anything else that might clog or enter the spring case.

Regulator dimensions are shown in Figure 3.

Capacity Information

Natural gas regulating capacities at selected inlet pressures and outlet pressure settings are given in Tables 2 and 3. Flows are in SCFH (60°F and 14.7 psia) of 0.6 specific gravity natural gas. To determine the equivalent capacities for other gases, multiply the table capacity by the following appropriate conversion factor: 0.775 for air, 0.789 for nitrogen, 0.625 for propane, or 0.548 for butane. For gases of other specific gravities, multiply the given capacity by 0.775, and divide by the square root of the appropriate specific gravity.

Then, if capacity is desired in normal cubic meters per hour (Nm³/h) at 0°C and 1,01325 bar, multiply SCFH by 0.0268.

Ordering Information

When ordering, specify:

Application

1. Composition and specific gravity of gas (including chemical analysis if possible)
2. Range of temperatures

Industrial Regulators

Emerson Process Management Regulator Technologies, Inc.

USA - Headquarters
McKinney, Texas 75069-1872 USA
Tel: 1-800-558-5853
Outside U.S. 1-972-548-3574

Asia-Pacific
Shanghai, China 201206
Tel: +86 21 2892 9000

Europe
Bologna, Italy 40013
Tel: +39 051 4190611

Middle East and Africa
Dubai, United Arab Emirates
Tel: +971 4811 8100

Natural Gas Technologies

Emerson Process Management Regulator Technologies, Inc.

USA - Headquarters
McKinney, Texas 75069-1872 USA
Tel: 1-800-558-5853
Outside U.S. 1-972-548-3574

Asia-Pacific
Singapore, Singapore 128461
Tel: +65 6777 8211

Europe
Bologna, Italy 40013
Tel: +39 051 4190611
Gallardon, France 28320
Tel: +33 (0)2 37 33 47 00

TESCOM

Emerson Process Management Tescom Corporation

USA - Headquarters
Elk River, Minnesota 55330-2445 USA
Tel: 1-763-241-3238

Europe
Selmsdorf, Germany 23923
Tel: +49 (0) 38823 31 0

For further information visit www.fisherregulators.com

The Emerson logo is a trademark and service mark of Emerson Electric Co. All other marks are the property of their prospective owners. Fisher is a mark owned by Fisher Controls, Inc., a business of Emerson Process Management.

The contents of this publication are presented for informational purposes only, and while every effort has been made to ensure their accuracy, they are not to be construed as warranties or guarantees, express or implied, regarding the products or services described herein or their use or applicability. We reserve the right to modify or improve the designs or specifications of such products at any time without notice.

Emerson Process Management does not assume responsibility for the selection, use or maintenance of any product. Responsibility for proper selection, use and maintenance of any Emerson Process Management product remains solely with the purchaser.

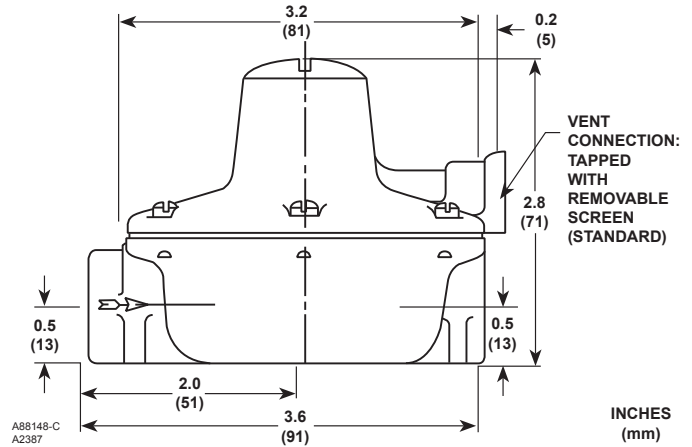

Figure 3. Dimensions

3. Flowing inlet pressures (maximum, minimum, nominal), and pressure drops
4. Desired outlet pressure setting or range
5. Range of flow rates (minimum controlled, maximum, normal)
6. Piping size(s)

Construction

Carefully review the information found in the Specifications section on page 2 and in each referenced table or figure. Specify the desired choice whenever a selection is offered. Always be sure to specify the regulator type number. For information on UL Listed constructions, contact your local Sales Office.