

ASCO SERIES 346 Digital Power Control System



ASCO[®]

EMERSON[™]
Network Power



**FOR COMMERCIAL, HEALTHCARE,
DATACENTERS AND INDUSTRIAL
FACILITIES...WHEREVER CONTROL
OF ON SITE GENERATORS IS NEEDED**

The ASCO SERIES 346 Digital Power Control System is a standardized generator paralleling system offering the sophisticated functionality normally found in custom designs.

- Reliably starts, synchronizes, parallels, monitors and protects engine-generator sets for prime power and emergency power applications.
- Smoothly integrates engine-generator sets and power transfer switches.
- Automatic load management control. One priority block per generator, each handling up to eight loads per priority block, up to four generators.
- Provides full, self-contained configurability. No need for a laptop.
- Includes communication ports that provide internet and intranet access to system status and functions.
- Easy to install, set up, commission, operate and service.





SERIES 346 Digital Power Control System

The ASCO SERIES 346 Power Control System offers wide-ranging features that make your facility's emergency power system more effective and efficient.

Digital microprocessor-based technology streamlines and simplifies total generator load control and engine management. The entire control system fits into one enclosure.

The technology is compatible with engines equipped with an electronic engine speed controller and voltage regulator.

A significantly smaller footprint meets the demanding requirements of tight or unconventional floor spaces.

Quicker manufacturing lead times and standardized configuration produce faster delivery.

Door-mounted, software-based display screens communicate easy-to-understand information in less space.

Digital metering measures voltage, amps, watts and frequency. It also includes protective relay functions as standard features.

Drawout insulated-case circuit breakers that parallel the generator to the emergency bus are an integral part of the system's design.

The system is rated at 800 to 3,000 amperes per generator.

It, of course, meets or exceeds the requirements of UL 891 and applicable standards of NEMA, IEEE, and ANSI. The system is labeled UL 891.





World-class technology for reliable power transfer



INDEPENDENT GENERATOR CONTROL

Independent Digital Generator Control Panels manage emergency standby systems comprised of up to four engine-generators

Independent microprocessor-based Digital Generator Control Panels provide complete generator load control and engine management for generators ranging in capacity from 250 kW to 2 MW.

Each control panel monitors an engine-generator, displays parameters for that engine-generator, annunciates generator and engine alarms, and controls engine speed and generator voltage for synchronizing and isochronous load sharing.

The panels automatically synchronize voltage and frequency, and match phase angles within two degrees of phase and 0.1 percent of voltage. Real (kW) load control and reactive (kVAR) controls are also included.

Each control panel also operates its respective generator circuit breaker, integral to the system, for paralleling or shutdown. Safe dead bus closing ensures that only one generator connects to the bus at a time.

Using integrated control logic, the system transfers the highest priority block of load to the first engine-generator that produces acceptable voltage and frequency.

Operator interface screens display:

- System status
- Engine status
- Generator metering
- DGCP input/output
- Synchronization status
- Load status
- PF/kVAR status
- Alarm/ Event log

The control panels have five levels of built-in security to protect against configuration changes and alarm purges by unauthorized personnel. A laptop is not required to configure the system.

A Modbus® RTU RS422 port enables communication to remote systems and allows those systems to access engine and generator parameters.

Maximum Reliability & Excellent Value

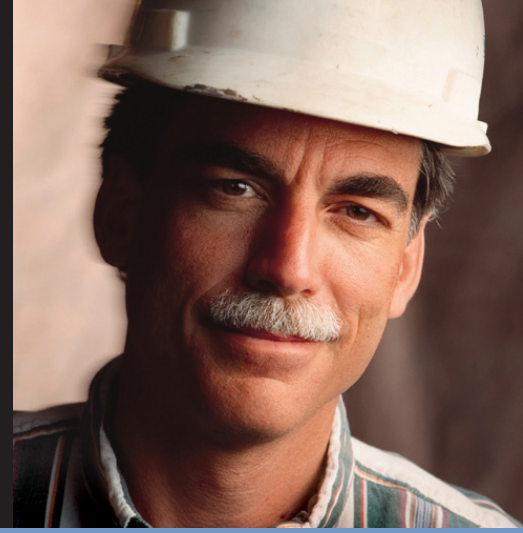

SYSTEM FUNCTIONS

Generator Protection

- Device 27/59- Under and Over Voltage
- Device 81- Under and Over Frequency
- Device 32- Reverse Power (Inverse Time Delay)
- Device 40- Loss of Excitation
- Device 81U- Bus Under Frequency
- Over Current (Inverse Time Delay)

Synchronizing

- Phase Match Synchronization
- 3 Mode Operation: Run, Check, Permissive
- Voltage Matching
- Dead Bus Closing
- Synch Timer
- Reclose Attempt/Timer
- Manual Synchronization (Permissive Mode)

Generator Voltage And Reactive Load Control

- Power Factor Sharing In Load Sharing Mode
- Externally Adjustable Var/Pf Reference
- Manual Voltage Control

AC Metering

- 3 Phase Voltage
- 3 Phase Current
- kWh
- kW, kVA, and kVAR
- Power Factor
- Frequency

Engine Control

- Multiple Crank Cycle Timer
- Crank Timer
- Crank Fail Alarm/Shutdown
- Crank Cutout (Rpm)
- Engine Preglow
- Idle/Rated Relay Output
- Engine Runtime

Engine Protection

- Oil Pressure -Over/Under Alarm/Shutdown Settings
- Water Temperature - Over/Under Alarm/Shutdown Settings
- Battery Voltage - Over/Under Alarm/Shutdown Settings
- Overspeed - Alarm/Shutdown Settings

Priority load management



A Generator Control Station includes a five-position selector switch for each engine generator. The settings are lockout/reset, off/cool-down, automatic test off line and test on line. Indicator lights signal when the generator is running and when controls are not in the automatic operation.

One priority block per generator with eight loads per block, such as electrically operated load distribution circuit breakers or power transfer switches, can be block load controlled.

An under frequency monitor on the main bus monitors generator loading.

Lowest priority loads will be shed automatically so critical priority one loads stay energized if the generators become overloaded, if one of the running generators fails, or if one of the generators

fails to start when a power outage occurs.

Visual indication identifies the status of priority load blocks and a push-button allows for a manual override of shed load blocks.

Load demand management Available on Two Engine Systems



A System Control Station includes an alarm horn with alarm silence push-button. Push-buttons are also included for resetting priority two loads and the under frequency alarm. Visual indication provides status of priority two, three or four loads and emergency mode operation.

(Accessory LD)

In the optional load demand mode with more than one generator online, the system monitors total load demand. If the load falls below 80% of rated output of the highest priority generators, lower priority engines (selectable) will shut down after an adjustable time delay. If the load increases above 90% of rated output of the highest priority generators already operating, the next priority engine will be signaled to start and come online after an adjustable time delay.

If an under-frequency bus condition is detected, the system will exit load demand mode and signal all additional engines to start and come online. If an engine fails while in load demand mode, all additional generators will be signaled to start and come online, and the lowest priority loads will be shed.

Communication Products



ASCO 5500 Thin Web Server.

The optional ASCO 5500 Thin Web Server provides Web-enabled control.

An operator or supervisor can monitor various transfer switch, engine and generator parameters remotely using the Thin Web Server.

The server provides real time access and control of critical power system performance.

Users can manage, check system status and recognize potential system failure.

It requires no dedicated hardware or software to operate and can be connected to any standard PC with a Microsoft® Internet Explorer browser.

E-mail and text paging features alert users of abnormal conditions.



ASCO 5150 Connectivity Module.

The optional ASCO 5150 Connectivity Module provides Ethernet and RS485 Communications to ASCO Transfer Switch controllers and ASCO Power Managers.

Embedded HTML pages are provided for monitoring of electrical parameters and alarms. The communication

format will support up to 8 clients simultaneously over an Ethernet Connection.

An ASCO 5110 communication module also available with only RS485 communications for monitoring and control with ASCO PowerQuest® systems.



ASCO 5350 Remote Annunciator.

The ASCO 5350 Power Transfer Switch Remote Annunciator is a stand-alone, industrial grade interface device providing you with the most critical transfer switch status indication and transfer/retransfer control for up to eight switches. Ethernet technology is built in for faster and more reliable communications. LEDs

indicate switch status and position, while separate push buttons individually initiate transfer switch operation and testing. Transfer switch annunciators can be set up in multiple locations to monitor various transfer switches, allowing redundant and distributed annunciation.

Network Your Emergency Power System

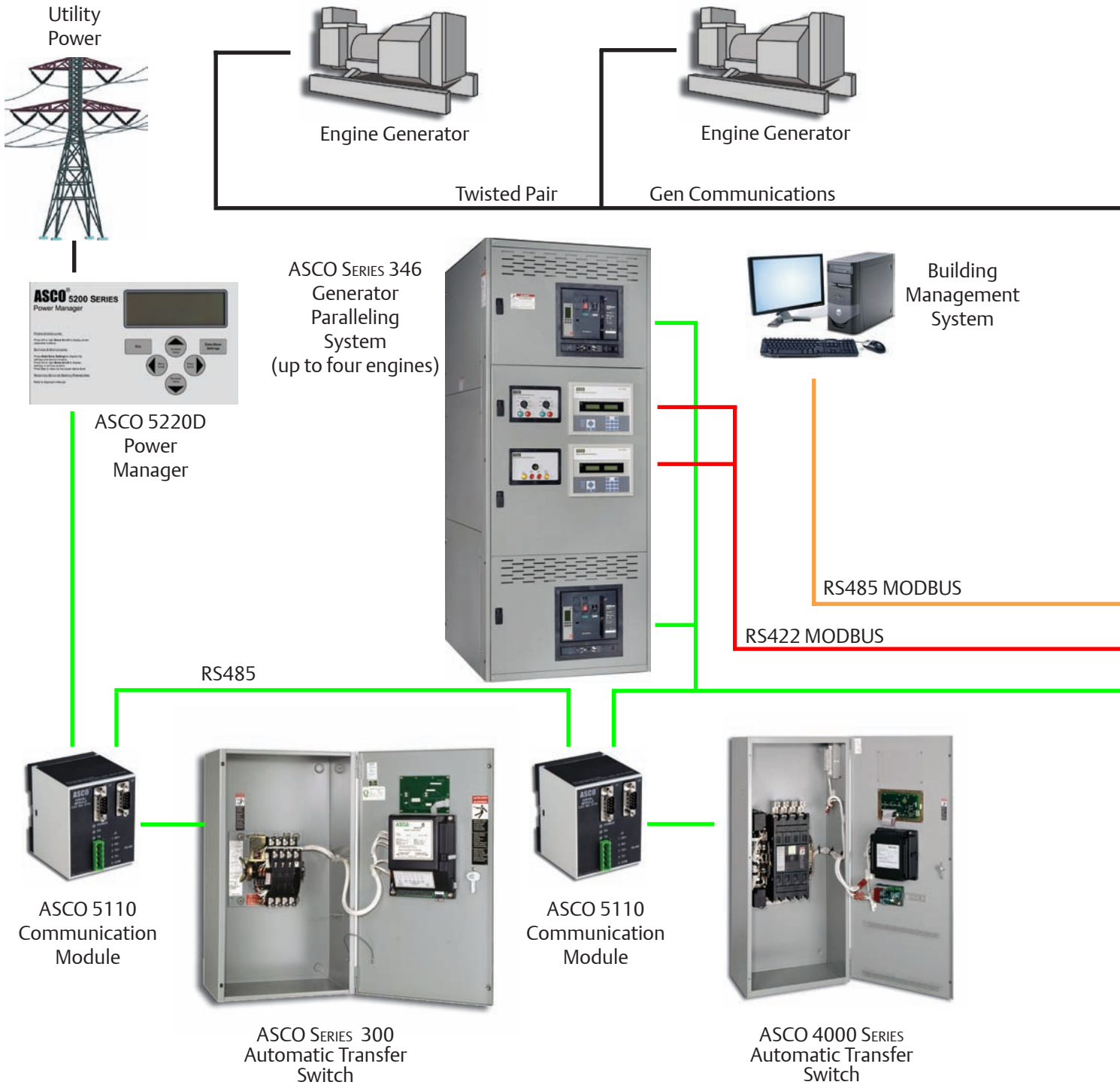

ASCO communications products allow for the monitoring and control of your emergency or standby power distribution system. Local area networks and remote networks are supported with either single or multiple points of access, and web-enabled communications allow access to your power system from anywhere in the world.

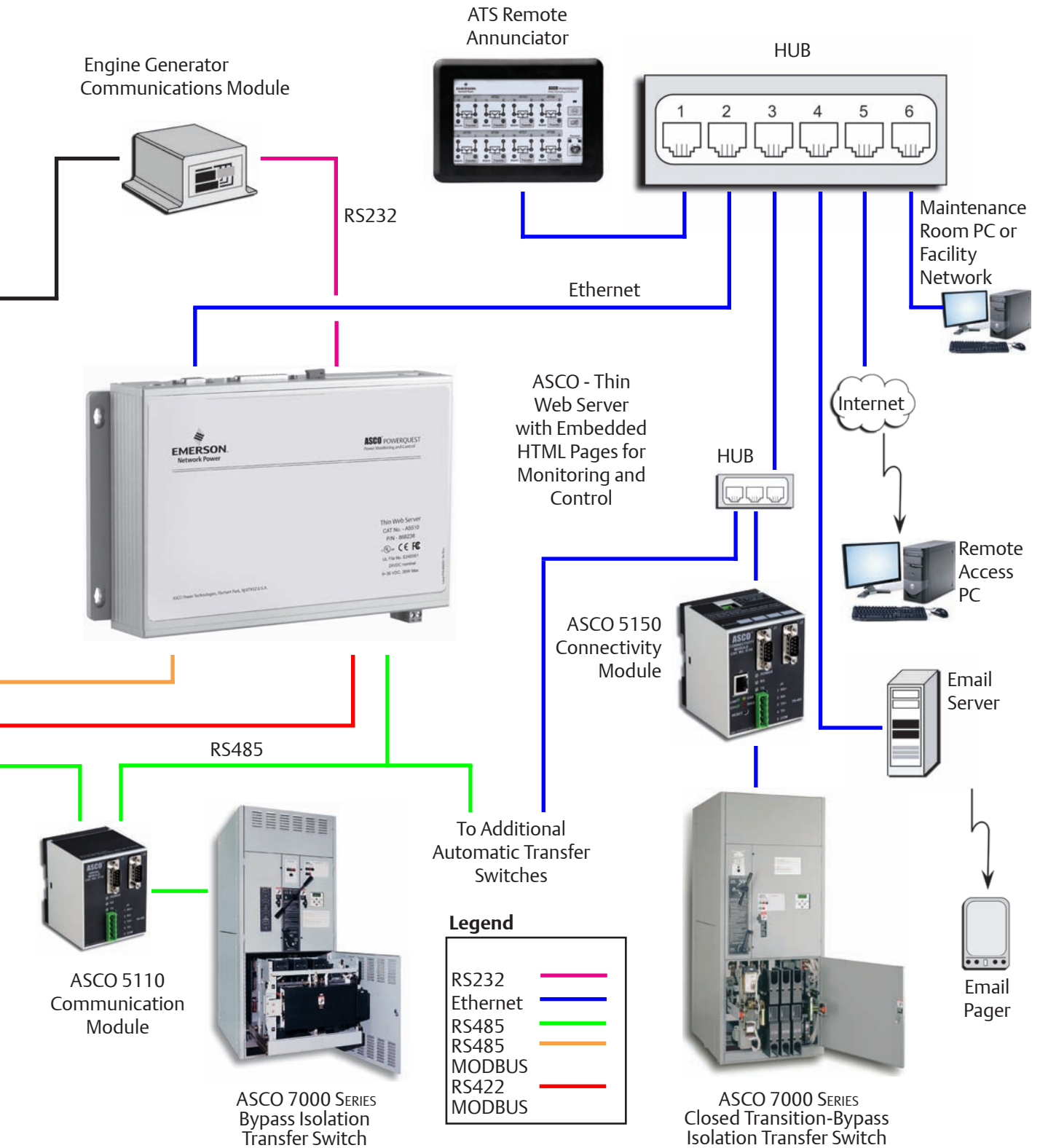

Generator Breakers

Generator circuit breakers offer drawout convenience to simplify maintenance or replacement.

Electrically-operated front-serviceable drawout breakers are available in 800 amp to 3000 amp frame sizes. The Square D, NW, 5.0P insulated case circuit breakers are UL 489 listed and are included with an adjustable long time delay, short time delay, instantaneous overcurrent trip and ground fault alarm.

Additional features include 120VAC electrical operation, 24 VDC shunt

trip, bell alarm, 4a and 4b auxiliary contacts, a protective cover for the manual close pushbutton, and instantaneous and ground fault indications.

Square D Micrologic 5.0P Trip units provide monitoring of electrical parameters as well as visual indication. Trip settings are adjustable from 40 % to 100% of the generator breaker frame size and a Modbus® RTU port provides communications to the Emergency Power Communication System.



Generator breaker and bus ampacity^{1,3}

GEN SIZE (kw @480V)	Breaker Frame (Amps)	Breaker Trip (Amps) ²	Phase & Neutral Bus (Amps)	Ground Bus (Amps)
230 - 500	800	800	2500	1000
300 - 650	1200	1000	2500	1000
350 - 800	1200	1200	2500	1000
450 - 1000	1600	1600	4000	1000
550 - 1250	2000	2000	4000	1000
700 - 1500	2500	2500	6000	2000
800 - 2000	3000	3000	6000	2000

1. Square D MASTERPACT® NW Insulated Case Circuit Breaker
 2. Adjustable Trip Settings 40% to 100% of Breaker Frame Size
 3. Bus bracing level 100,000 amperes.

ORDERING INFORMATION

To order an ASCO 346 SERIES Generator Paralleling System, complete the following catalog number.

Product	Amperes	Lug Type		Voltage Code ¹		Frequency Code		Enclosure Depth ²		Enclosure ³		
346 (2 Gens)	0800	M	Mechanical	A	115	5	50 Hz	4	48"	C1	NEMA Type 1	
	1000	C	Compression	B	120	6	60 Hz	6	60"		ANSI 61 Gray	
	1200			C	208			7	72"	F1	NEMA Type 3R	
347 (4 Gens)	1600			D	220			8	84"		ANSI 61 Gray	
	2000			E	230					C2	NEMA Type 1	
	2500			F	240						ANSI 49 Gray	
	3000			H	380					F2	NEMA Type 3R	
					J	400						ANSI 49 Gray
					K	415						
					L	440						
					M	460						
					N	480						
					P	550						
				Q	575							
				R	600							

1. Consult the factory for systems other than 3 phase, 4 wire

2. NEMA 1 systems 1200 amps and below are provided at 48" deep standard with an option to increase the depth to 60" or 72". NEMA 1 systems 1600 amps and above are provided 60" deep as standard with an option to increase the depth to 72". NEMA 3R systems 1200 amps and below are provided 60" deep standard with an option to increase the depth to 72" or 84". Nema 3R systems 1600 amps are provided 72" deep standard with an option to increase the depth to 84".

3. ANSI 61 Gray Standard.

The Example Catalog Number Above is 3460800MN64C

Sizes of UL-Listed Solderless Screw-Type Terminals for External Power Connections

Generator Breaker Rating amps	Max # of Conductors per Gen Terminal	Max # of Conductors per Load Terminal	Max # of Ground Bus Conductors	Range of CU Conductor Sizes	Range of AL Conductor Sizes
800	4	8	2	3/0 to 800 MCM	250 to 800 MCM
1000	5	10	3	3/0 to 800 MCM	250 to 800 MCM
1200	5	10	3	3/0 to 800 MCM	250 to 800 MCM
1600	6	12	3	3/0 to 800 MCM	250 to 800 MCM
2000	7	14	4	3/0 to 800 MCM	250 to 800 MCM
2500	8	16	4	3/0 to 800 MCM	250 to 800 MCM
3000	9	18	5	3/0 to 800 MCM	250 to 800 MCM

Pull Box Options³

Pull Box with out provisions for overhead lifting device¹

Enclosure Depth in (mm)	Accessory	Height in (mm)	Depth	Accessory	Height in (mm)	Depth in (mm)
48 (1219)	42A1	12 (305)	48 (1219)	42A4	24 (610)	48 (1219)
60 (1524)	42A2	12 (305)	60 (1524)	42A5	24 (610)	60 (1524)
72 (1829)	42A3	12 (305)	72 (1829)	42A6	24 (610)	72 (1829)

Pull Box with provisions for overhead lifting device^{1,2}

Enclosure Depth in (mm)	Accessory	Height in (mm)	Depth	Accessory	Height in (mm)	Depth in (mm)
48 (1219)	42B1	12 (305)	24 (610)	42B4	24 (610)	24 (610)
60 (1524)	42B2	12 (305)	36 (914)	42B5	24 (610)	36 (914)
72 (1829)	42B3	12 (305)	48 (1219)	42B6	24 (610)	48 (1219)

1. All pull boxes are NEMA 1, top mounted 36" wide.

2. An overhead circuit breaker lifting device with trolley, rails and mounting rails is available. Order as accessory 82.

3. Shipped separately, must be installed by contractor.

Dimensions and Shipping Weights

NEMA 1 (per section)**

800-1200 Amp

* Optional Enclosure Depths
Code, 6 - 60 Inches
Code, 7 - 72 Inches

Shipping Weights**

Amps	Depth in(mm)	Enclosed Weight lb(kg)
800 - 1200	48 (1219)	1964 (892)
800 - 1200	60 (1524)	2024 (920)
800 - 1200	72 (1829)	2085 (948)

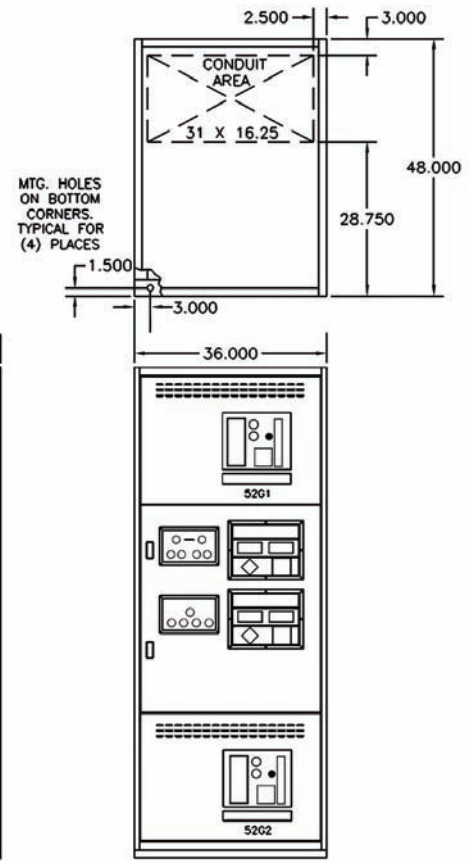
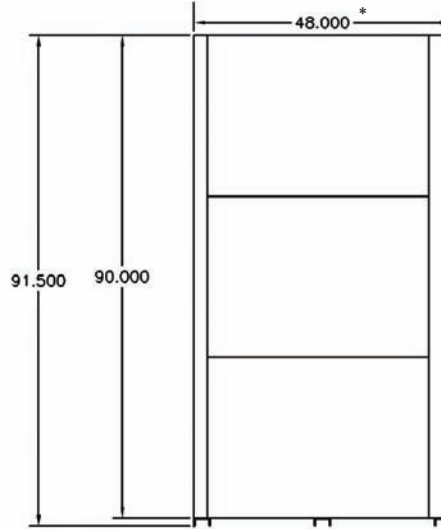

Dimensions and Shipping Weights

NEMA 1 (per section)**

1600-3000 Amp

* Optional Enclosure Depths
Code, 7 - 72 Inches

Shipping Weights**

Amps	Depth in(mm)	Enclosed Weight lb(kg)
1600 - 2000	60 (1524)	2085 (947)
1600 - 2000	72 (1829)	2206 (1003)
2500 - 3000	60 (1524)	2385 (1084)
2500 - 3000	72 (1829)	2506 (1139)

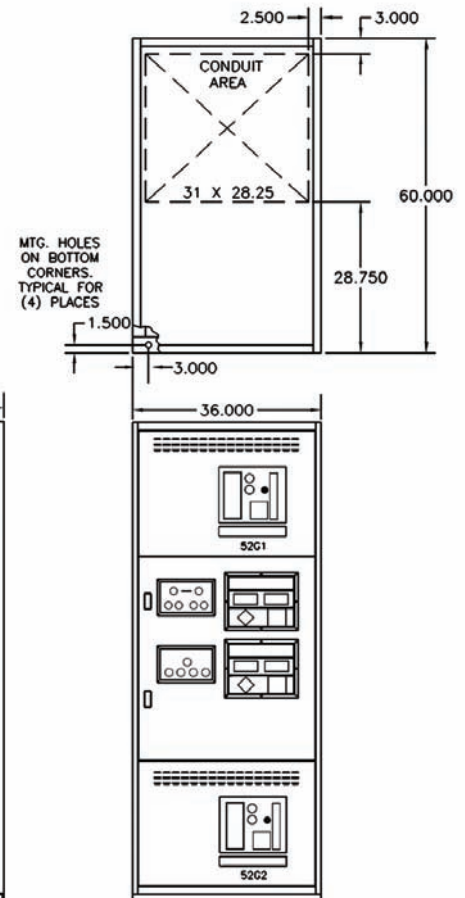
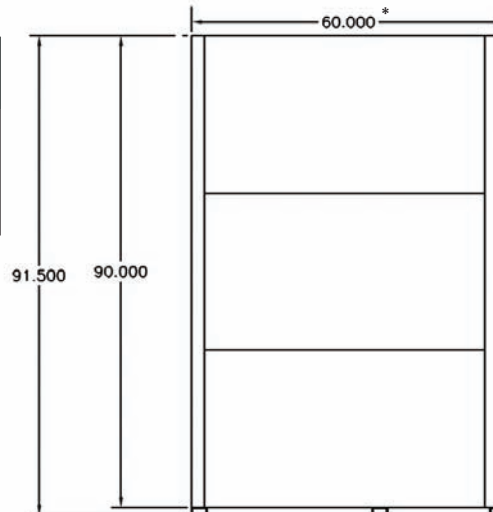

**Single section for two-generator systems; second section required for four generator systems

Dimensions and Shipping Weights

NEMA 3R (per section) **

800-1200 Amp

* Optional Enclosure Depths
Code, 7 - 72 Inches
Code, 8 - 84 Inches

Shipping Weights **

Amps	Depth in(mm)	Enclosed Weight lb(kg)
800 - 1200	60 (1524)	2274 (1034)
800 - 1200	72 (1829)	2334 (1061)
800 - 1200	84 (2134)	2395 (1089)

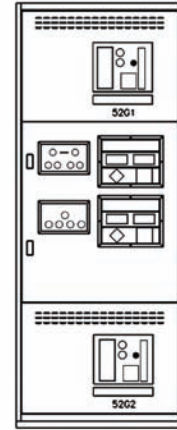
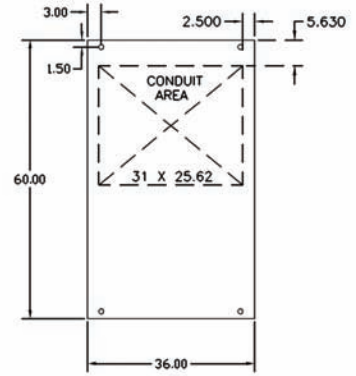
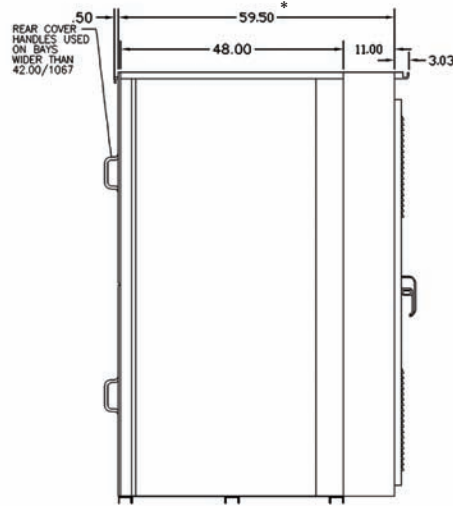

Dimensions and Shipping Weights

NEMA 3R (per section) **

1600-3000 Amp

* Optional Enclosure Depths
Code, 8 - 84 Inches

Shipping Weights **

Amps	Depth in(mm)	Enclosed Weight lb(kg)
1600 - 2000	72 (1829)	2395 (1089)
1600 - 2000	84 (2134)	2516 (1144)
2500 - 3000	72 (1829)	2695 (1225)
2500 - 3000	84 (2134)	2739 (1245)

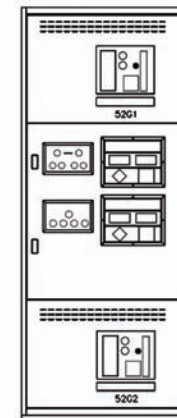
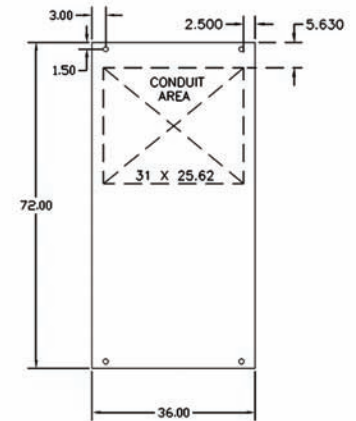
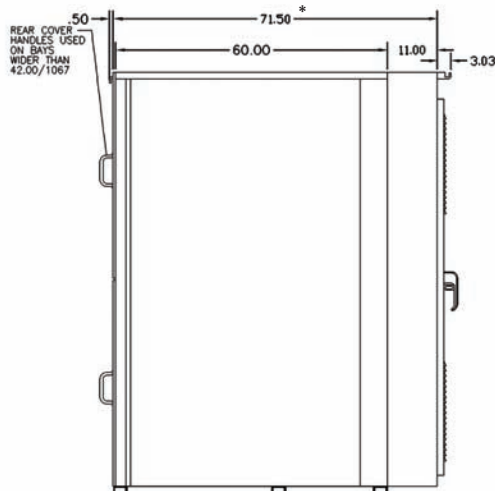

** Single section for two-generator systems; second section required for four generator systems

ASCO Power Technologies®

ASCO Power Technologies
50 Hanover Road
Florham Park, NJ 07932
USA

800 800 ASCO
www.ascopower.com
www.ascoapu.com

Emerson Network Power.

The global leader in enabling *Business-Critical Continuity™*.

- | | | | |
|----------------|--|------------------------------|-------------------------------|
| ■ AC Power | ■ Embedded Computing | ■ Outside Plant | ■ Racks & Integrated Cabinets |
| ■ Connectivity | ■ Embedded Power | ■ Power Switching & Controls | ■ Services |
| ■ DC Power | ■ Infrastructure Management & Monitoring | ■ Precision Cooling | ■ Surge Protection |

Emerson Network Power and the Emerson Network Power logo are trademarks and service marks of Emerson Electric Co. ©2009 Emerson Electric Co.

Publication 3121 R4

© May, 2009

Printed in the U.S.A.