



Epsilon EP Drive

Installation Manual

P/N 400518-01

Revision: A1

Date: December 15, 2006

© Control Techniques Americas LLC, 2006



EMERSON[™]
Industrial Automation

Epsilon EP Drive Installation Manual



Information furnished by Control Techniques Americas LLC (Control Techniques) is believed to be accurate and reliable. However, no responsibility is assumed by Control Techniques for its use. Control Techniques reserves the right to change the design or operation of the equipment described herein and any associated motion products without notice. Control Techniques also assumes no responsibility for any errors that may appear in this document. Information in this document is subject to change without notice.

P/N 400518-01

Revision: A1

Date: December 15, 2006

© Control Techniques Americas LLC, 2006

© Control Techniques Americas LLC, 2006

Part Number: 400518-01

Revision: A1

Date: December 2006

Printed in United States of America

Information in this document is subject to change without notice. No part of this document may be reproduced or transmitted in any form or by any means, electronic or mechanical, for any purpose, without the express written permission of Control Techniques Americas LLC.

Control Techniques Americas LLC a division of EMERSON Co.

Control Techniques Americas LLC is not affiliated with Microsoft Corporation, owner of the Microsoft, Windows, and Windows NT trademarks.

Modbus is a trademark of Gould, Inc.

Schaffner is a trademark of Schaffner

Mate-N-Lok is a trademark of Amp Incorporated Corp.

DeviceNet is a trademark of Open DeviceNet Vendor Association.

Reference Materials

The following related reference manuals may be useful with your particular system.

Epsilon EP-I Indexing Drive and FM-2 Indexing Module Reference Manual (400518-02)

Epsilon EP-B Drive Reference Manual (400518-03)

Epsilon EP-P Drive and FM-3/4 Modules Reference Manual (400518-04)

Epsilon EP-P Drive Connectivity Reference Manual (400518-05)

Epsilon EP-IDN DeviceNet Reference Manual (400518-08)

This document has been prepared to conform to the current released version of the product. Because of our extensive development efforts and our desire to further improve and enhance the product, inconsistencies may exist between the product and documentation in some instances. Call your customer support representative if you encounter an inconsistency.

Safety Information

Safety Precautions

This product is intended for professional incorporation into a complete system by qualified persons. If you install the product incorrectly, it may present a safety hazard. The product and system may use high voltages and currents, carry a high level of stored electrical energy, or are used to control mechanical equipment that can cause injury. You must give close attention to the electrical installation and system design to avoid hazards either in normal operation or in the event of equipment malfunction. System design, installation, commissioning and maintenance must be carried out by personnel who have the necessary training and experience. Read and follow this safety information and this instruction manual carefully.

Qualified Person

For the purpose of this manual and product, a “qualified person” is one who is familiar with the installation, construction and operation of the equipment and the hazards involved. In addition, this individual has the following qualifications:

Is trained and authorized to energize, de-energize, clear and ground and tag circuits and equipment in accordance with established safety practices.

Is trained in the proper care and use of protective equipment in accordance with established safety practices.

Is trained in rendering first aid.

Enclosure

This product is intended to be mounted in an enclosure that prevents access except by qualified persons and that prevents the ingress of contamination. This product is designed for use in an environment classified as pollution degree 2 in accordance with IEC664-1. This means that only dry, non-conducting contamination is acceptable.

Setup, Commissioning and Maintenance

It is essential that you give careful consideration to changes to drive settings. Depending on the application, a change could have an impact on safety. You must take appropriate precautions against inadvertent changes or tampering. Restoring default parameters in certain applications may cause unpredictable or hazardous operation.

Safety of Machinery

Within the European Union all machinery in which this product is used must comply with Directive 89/392/EEC, Safety of Machinery.

The product has been designed and tested to a high standard, and failures are very unlikely. However the level of integrity offered by the product’s control function – for example stop/start, forward/reverse and maximum speed – is not sufficient for use in safety-critical applications without additional independent channels of protection. All applications where malfunction could cause injury or loss of life must be subject to a risk assessment, and further protection provided where needed.

Identification of Safety Information

Safety related information through out this manual is identified with the following markings.



“Warning” indicates a potentially hazardous situation that, if not avoided, could result in death or serious injury.



“Caution” indicates a potentially hazardous situation that, if not avoided, may result in minor or moderate injury.

CAUTION

“Caution” used without the safety alert symbol indicates a potentially hazardous situation that, if not avoided, may result in property damage.

NOTE

For the purpose of this manual and product, “Note” indicates essential information about the product or the respective part of the manual.

Throughout this manual, the word “drive” refers to an Epsilon EP drive.

⚠ WARNING**General warning**

Failure to follow safe installation guidelines can cause death or serious injury. The voltages used in this unit can cause severe electric shock and/or burns, and could be lethal. Extreme care is necessary at all times when working with or adjacent to this equipment. The installation must comply with all relevant safety legislation in the country of use.

Supply isolation device

The AC supply or high voltage DC supply must be removed from the drive using an approved isolation device or disconnect before any servicing work is performed, other than adjustments to the settings or parameters specified in the manual. The drive contains capacitors which remain charged to a potentially lethal voltage after the supply has been removed. Allow at least 6 minutes for Epsilon EP206 and 3 minutes for Epsilon EP202/204 after removing the supply before carrying out any work which may involve contact with electrical connections to the drive.

Products connected by plug and socket

A special hazard may exist where the drive is incorporated into a product which is connected to the AC supply by a plug and socket. When unplugged, the pins of the plug may be connected to the drive input, which is only separated from the charge stored in the bus capacitor by semiconductor devices. To avoid any possibility of electric shock from the pins, if they are accessible, a means must be provided for automatically disconnecting the plug from the drive (e.g., a latching contactor).

Grounding (Earthing, equipotential bonding) - High Leakage Current

The drive must be grounded by a conductor sufficient to carry all possible fault current in the event of a fault. This equipment has high earth leakage current. You must comply with local safety regulations with respect to minimum size and special installation requirements on the protective earth conductor for high leakage current equipment. The ground connections shown in the manual must be followed.

Fuses

Fuses or over-current protection must be provided at the input in accordance with the instructions in the manual.

Isolation of control circuits

The installer must ensure that the external control circuits are isolated from human contact by at least one layer of insulation rated for use at the applied AC supply voltage. External control circuits identified as PELV circuits do not need this isolation when they are completely within a zone of equipotential bonding, generally within a single enclosure or group of enclosures bonded together.

Underwriters Laboratories Listed

LISTED 51Y8
IND. CONT. EQ.
File E 58592 Sec.5



The Epsilon Digital Servo Drives are marked with the “UL Listed” label after passing a rigorous set of design and testing criteria developed by UL (UL508C). This label indicates that UL certifies this product to be safe when installed according to the installation guidelines and used within the product specifications.

The “conditions of acceptability” required by UL are:

- Operating within ratings for Input Voltage, Input Current, and Output Current

Rated Output Current (Amps RMS)		
Drive Model	Continuous (Full Load Amperes)	Peak
EP202	2.2	4.4
EP204	4.0	8.0
EP206	6.5	13.0

- Epsilon drive maximum surrounding air temperature 40° C (104° F) at rated Full Load Amperes (FLA)
- Epsilon drive maximum surrounding air temperature 50° C (122° F) with output current derated 20% for EP206, 10% for EP204, and no derating required for EP202
- Integral solid state short circuit protection does not provide branch circuit protection. Branch circuit protection must be provided in accordance with the National Electrical Code and any additional local codes.
- Copper only conductors with 75°C minimum insulation rating at all power and motor terminals
- This product is suitable for use on a circuit capable of delivering not more than 10,000 RMS symmetrical amperes, 240 volts maximum, when protected by a Class RK1 or Class CC fuse, rated not more than 15 A
- Logic power and I/O power are to be supplied with a UL listed or "recognized component" power supply rated as limited voltage/limited current or limited voltage/limited power
- The following warning is presented here and furnished on a label to be placed on the enclosure door

WARNING

Drive has high fault current rating. The opening of the branch circuit protective device may be an indication that a fault current has been interrupted. All current carrying ports and other components protected by this device should be examined and replaced if damaged. If burn-out of the current element of an overload relay occurs, the complete overload relay must be replaced.

Drive Overload Protection

Solid state motor overload protection is provided in each model at no more than 115% of rated FLA. This overload protection is based on maximum continuous output current capacity. It will allow up to 200 percent of drive FLA to be delivered for the amount of time determined by the following chart.

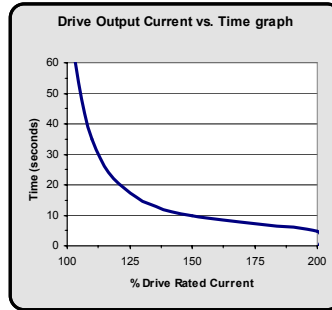

When motor rated FLA is less than drive FLA, the motor FLA parameter is to be entered into drive configuration. Drive will then provide motor overload protection at correct value.

CE Declaration of Conformity

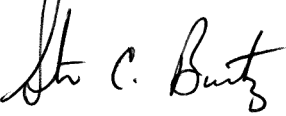

The Epsilon Digital Servo Drives are marked with the “Conformite Europeenne Mark” (CE mark) after passing a rigorous set of design and testing criteria. This label indicates that this product meets safety and noise immunity and emissions (EMC) standards when installed according to the installation guidelines and used within the product specifications.

Declaration of Conformity	
Manufacturer's Name:	Control Techniques Americas LLC
Manufacturer's Address:	12005 Technology Drive Eden Prairie, MN 55344 USA
Declares that the following products:	
Product Name:	Epsilon EP Digital Servo Drive
Model Number:	EP202-B00, EP202-I00, EP202-IDN, EP202-P00, EP202-PDN, EP204-B00, EP204-I00, EP204-IDN, EP204-P00, EP204-PDN, EP206-B00, EP206-I00, EP206-IDN, EP206-P00, EP206-PDN
System Options:	STI-24IO Interface Board, STI-SNCOA Analog/Sync Output Interface Board, STI-SNCI Sync Input Interface Board, BRM-1 Motor Brake Relay, and SM-Heatsink DBR-1 Brake Resistor
Conforms to the following product specification:	
Electromagnetic Compatibility (EMC):	EN 61800-3; 1997, For second environment restricted distribution
Electrical Thermal and Energy Safety Requirements:	EN 61800-5-1:2003
Supplementary information:	
The products herewith comply with the requirements of the Low Voltage Directive (LVD) 73/23/EEC and amended by 93/68/EEC and the EMC Directive 89/336/EEC	
This servo drive is intended to be used with an appropriate motor, electrical protection components and other equipment to form a complete end product or system. It must be installed by a professional assembler who is familiar with safety and electromagnetic compatibility (“EMC”) requirements. The assembler is responsible for ensuring that the end product or system complies with all the relevant laws in the country where it is to be used. Refer to the product manual for installation guidelines.	
	December 12, 2006
Steve Bartz Director, Motion Control Product Line	Date
European Contact:	Sobetra Automation Langeveldpark Lot 10 P. Dasterleusstraat 2 1600 St. Pieters Leeuw, Belgium

Safety Information	Product Overview	Installation	Diagnostics	Options and Accessories	Specification
---------------------------	------------------	--------------	-------------	-------------------------	---------------

Table of Contents

Reference Materials	ii
Safety Information	iii
Safety Precautions	iii
Qualified Person	iii
Enclosure	iii
Setup, Commissioning and Maintenance	iii
Safety of Machinery	iii
Identification of Safety Information	iii
Underwriters Laboratories Listed	v
Drive Overload Protection	vi
CE Declaration of Conformity	vii
Product Overview	1
Epsilon EP Drive	1
Installation	3
Step 1: Basic Installation Guidelines	3
Electromagnetic Compatibility (EMC)	3
Achieving Low Impedance Connections	3
Electrostatic Discharge (ESD) Protection	4
Environmental Considerations	4
Wiring Notes	4
Panel Layout	5
Cable to Enclosure Shielding	6
AC Line Filters	7
Step 2: Mechanical Installation	7
Step 3: High Power Connections	10
System Grounding	10
AC Power Requirements	11
Transformer Sizing	14
Line Fusing and Wire Size	16
AC Input Power Connections	17
Operation on DC Input Supply	17
External Shunt Electrical Installation	18
Motor Power Wiring	19
Step 4: Low Power Connections	22
DC Logic Power Supply Wiring	22

Motor Feedback Wiring (J6)	23
Motor Brake Wiring	25
Input/Output and Drive Enable Wiring	26
Analog Command Wiring	32
Encoder Output Signal Wiring	32
Communications	37

Diagnostics and Troubleshooting 41

Diagnostic Display	41
Status Codes	41
Fault Codes	42
Fault Descriptions	44
Diagnostic Analog Output Test Points	47
Drive Faults	47

Options and Accessories 49

Epsilon EP Drive Options	49
STI-24IO	50
STI-SNCOA	51
STI-SNCI	52
STI-ENC	53

Specifications 55

Epsilon EP Specifications	55
Epsilon EP Drive Dimensions	58
Cable Diagrams	59
XV Motor Cables	60
NT and MG Motor Cables	66
Sync Cables	69
Communications Cables	72

Index 73

Product Overview

Epsilon EP Drive

The Epsilon EP drive is a stand-alone, fully digital brushless servo drive designed and built to reliably provide high performance and flexibility without sacrificing ease of use.

The use of State-Space algorithms make tuning very simple and forgiving. The drives are designed to operate with up to a 10:1 inertia mismatch right out of the box. Higher (50:1 and more) inertia mismatches are possible with two simple parameter settings.

The Epsilon EP drive can be quickly configured to many applications in less than 5 minutes with PowerTools Pro software on a PC running Windows® 98, NT 4.0, 2000, ME and XP.

Complete diagnostics are provided for quick troubleshooting. A status/diagnostic display on the front of the drive informs the user of the operational or fault status. The last 10 faults are stored in non-volatile memory along with a time stamp for easy recall.

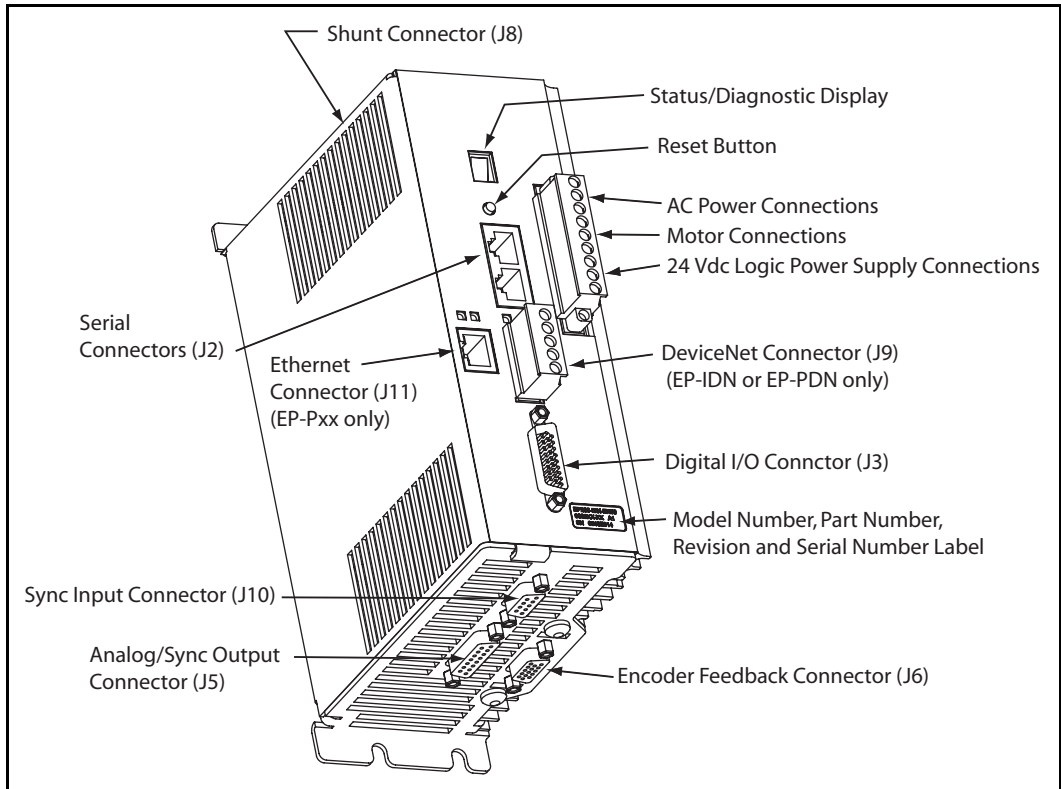

Figure 1: Epsilon EP-PDN Drive Feature Location

Epsilon EP drives are rated at 240 Vac input voltage and can operate with an input voltage from 20 to 264 Vac. The EP drives are available in three current ratings.

Drive Model	Continuous Power Rating	Continuous Current	Peak Current
Epsilon EP202	670 W	2.2 A RMS	4.4 A RMS
Epsilon EP204	1140 W	4.0 A RMS	8.0 A RMS
Epsilon EP206	1610 W	6.5 A RMS	13.0 A RMS

Installation

Installation of the Epsilon EP drive is completed by following a simple step-by-step process. The Epsilon EP installation begins by mounting the drive to a metal mounting panel. Next, the high power connections are made to the drive, then the low power connections are made.

Step 1: Basic Installation and Panel Layout, page 3

Step 2: Mechanical Installation, page 7

Step 3: High Power Connections, page 10

Step 4: Low Power Connections, page 22

Step 1: Basic Installation Guidelines

You are required to follow all safety precautions during start-up such as providing proper equipment grounding, correctly fused power and an effective Emergency Stop circuit which can immediately remove power in the case of a malfunction. See the "Safety Considerations" section for more information.

Electromagnetic Compatibility (EMC)

Drives are designed to meet the requirements of EMC. Under extreme conditions a drive might cause or suffer from disturbances due to electromagnetic interaction with other equipment. It is the responsibility of the installer to ensure that the equipment or system into which the drive is incorporated complies with the relevant EMC legislation in the country of use.

The following instructions provide you with installation guidance designed to help you meet the requirements of the EMC Directive 89/336/EEC.

Adhering to the following guidelines will greatly improve the electromagnetic compatibility of your system, however, final responsibility for EMC compliance rests with the machine builder, and Control Techniques Americas LLC cannot guarantee your system will meet tested emission or immunity requirements.

If you need to meet EMC compliance requirements, EMI/RFI line filters must be used to control conducted and radiated emissions as well as improve conducted immunity.

Physical location of these filters is very important in achieving these benefits. The filter output wires should be kept as short as practical and routed away from the filter input wires. In addition:

- Choose an enclosure made of a conductive material such as steel, aluminum or stainless steel.
- Devices mounted to the enclosure mounting plate, which depend on their mounting surfaces for grounding, must have the paint removed from their mounting surfaces and the mating area on the mounting plate to ensure a good ground. See "Achieving Low Impedance Connections" on page 3 for more information.
- If grounding is required for cable grommets, connectors and/or conduit fittings at locations where cables are mounted through the enclosure wall, paint must be removed from the enclosure surface at the contact points.
- Cables should be shielded, and all shields must be grounded to the enclosure.

To meet radiated emissions requirements, the enclosure door must be closed and have electrical conduction at hinges and closure hardware or be fitted with a conductive gasket. Route cables away from the door where possible to minimize coupling emissions to door where they can re-radiate. The door generally must be bonded to the enclosure for electrical safety, but this is not sufficient to meet EMC.

Achieving Low Impedance Connections

Noise immunity can be improved and emissions reduced by making sure that all the components have a low impedance connection to the same ground point. A low impedance connection is one that conducts high frequency current with very little resistance. Impedance cannot be accurately measured with a standard ohmmeter, because an ohmmeter measures DC resistance. For example, a 12 inch long 8 gauge round wire has a significantly higher impedance than a 12 inch long 12 gauge flat braided conductor. A short wire has less impedance than a long one.

Low impedance connections can be achieved by bringing large areas of conductive surfaces into direct contact with each other. In most cases this requires paint removal because a ground connection through bolt threads is not sufficient. However, component materials should be conductive, compatible and exhibit good atmospheric corrosion resistance to prevent loss through corrosion that will hinder the low impedance connection. Enclosure manufacturers offer corrosion resistant, unpainted mounting plates to help.

Bringing components into direct contact cannot always be achieved. In these situations a conductor must be relied upon to provide a low impedance path between components. Remember a flat braided wire has lower impedance than a round wire of a large gauge rating.

A low impedance connection should exist between the following components, but not limited to:

- Enclosure and mounting plate
- Enclosure and door, if door does not have RF gaskets
- Servo drive chassis and mounting plate
- EMI/RFI AC line filter chassis and mounting plate
- Other interface equipment chassis and mounting plate
- Other interface equipment chassis and electrical connectors
- Enclosure and conduit fittings or electrical connectors
- Enclosure mounting plate and earth ground
- Motor frame and conduit fittings or electrical connectors
- Encoder chassis and electrical connector

A good rule to follow when specifying conductors for high frequency applications is to use a metal strap with a length to width ratio that is less than 3:1.

Electrostatic Discharge (ESD) Protection



Do not allow ESD to the drive while operating.

Though no damage occurs with electrostatic discharge at levels tested for EMC compliance, ESD directly to the drive cover can interrupt proper drive operation. ESD to terminals on the breakout boards has not been evaluated because wiring to these terminals is a maintenance activity. When doing any maintenance activity, make sure static electric charge is drained off by touching the enclosure away from the drive before contacting the drive or its wiring terminals. Use of ground straps or other techniques to prevent static buildup is a necessary part of any maintenance activity.

Environmental Considerations

The drive is rated to operate only in a pollution degree 2 environment, meaning that normally only non-conductive pollution occurs and there is no condensation, but occasional condensation may occur when not operating.

If the installation environment contains atmospheric contaminants such as moisture, oils, conductive dust, chemical contaminants and metallic particles, you must mount it vertically in a metal NEMA type 12 enclosure.

To prevent operation with condensation present, it is best to energize the logic power several minutes before applying main power or keep logic power applied continuously.

If the ambient temperature inside the enclosure will exceed 40°C (104°F), you must consider forced air cooling.

NOTE

It is necessary to maintain the drive surrounding air temperature at 40°C (104°F) or 50°C (122°F) with appropriate derating or below to maintain the drive UL ratings. See specifications for derating by model.

The amount of cooling depends on the size of the enclosure, the thermal transfer of the enclosure to the ambient air and the amount of power being dissipated inside the enclosure. Consult your enclosure manufacturer for assistance with determining cooling requirements.

Wiring Notes

- To avoid problems associated with EMI (electromagnetic interference), you should route high power lines (AC input power and motor power) away from low power lines (encoder feedback, serial communications, etc.).
- If a neutral wire (not the same as Earth Ground) is supplied from the building distribution panel, it should never be bonded with PE wire in the enclosure.

- You should consider future troubleshooting and repair when installing all wiring. All wiring should be either color coded and/or tagged with industrial wire tabs.
- As a general rule, the minimum cable bend radius is ten times the cable outer diameter.
- All wiring and cables, stationary and moving, must be protected from abrasion.
- Ground wires should not be shared or "daisy-chained" with other equipment.
- Ensure that full metal to metal surface contact is made between the enclosure ground lug and the metal enclosure, not simply through the mounting bolt and threads.
- All inductive coils must be suppressed with appropriate devices, such as diodes or resistor/capacitor (RC) networks, except as described in this manual.
- If using a non-shielded Ethernet cable, install a clamp on ferrite, Control Techniques part number 157016-07, Steward 28A0593-0A2 or equivalent.

Panel Layout

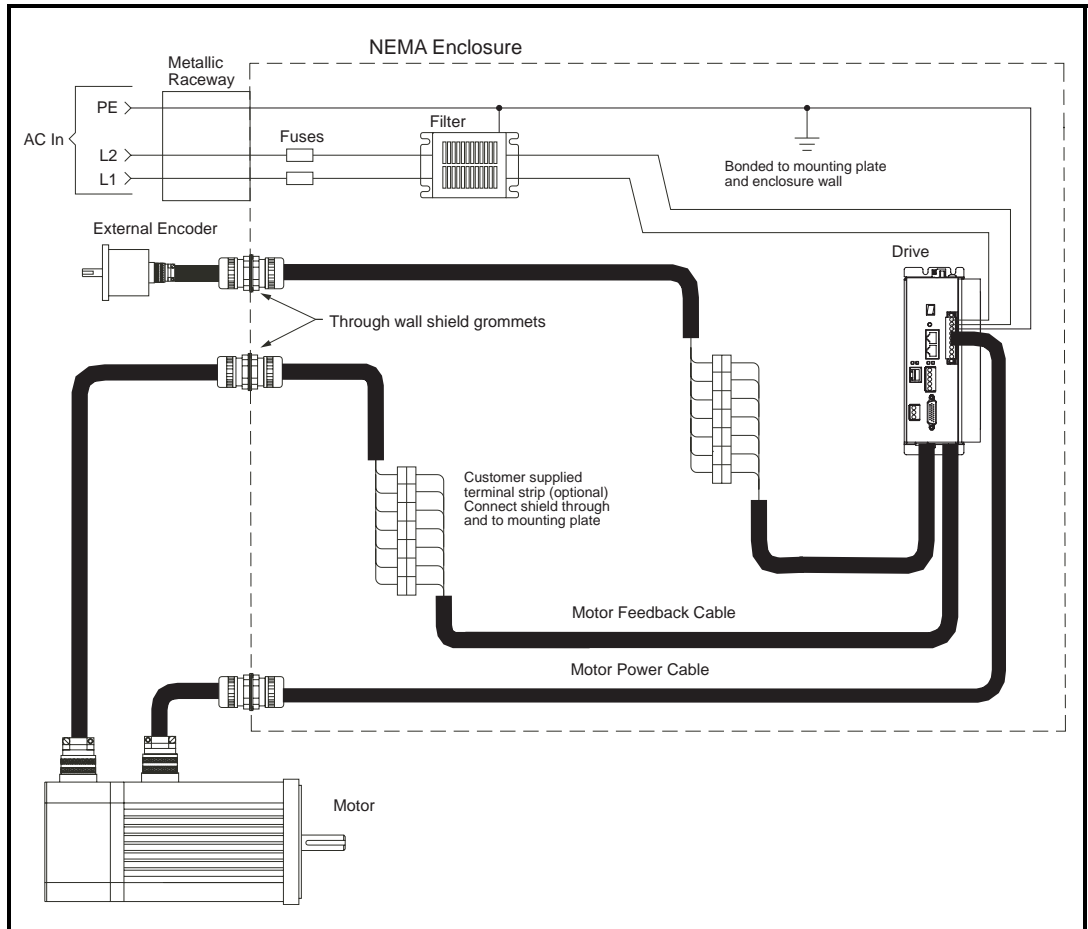

Figure 2: AC Filter and Cable Connections

Cable to Enclosure Shielding

Shielded motor, feedback, serial communications and external encoder cables were used for compliance testing and are necessary to meet the EMC requirements. Each cable shield was grounded at the enclosure wall by the type of grommet described earlier and shown in the following figure.

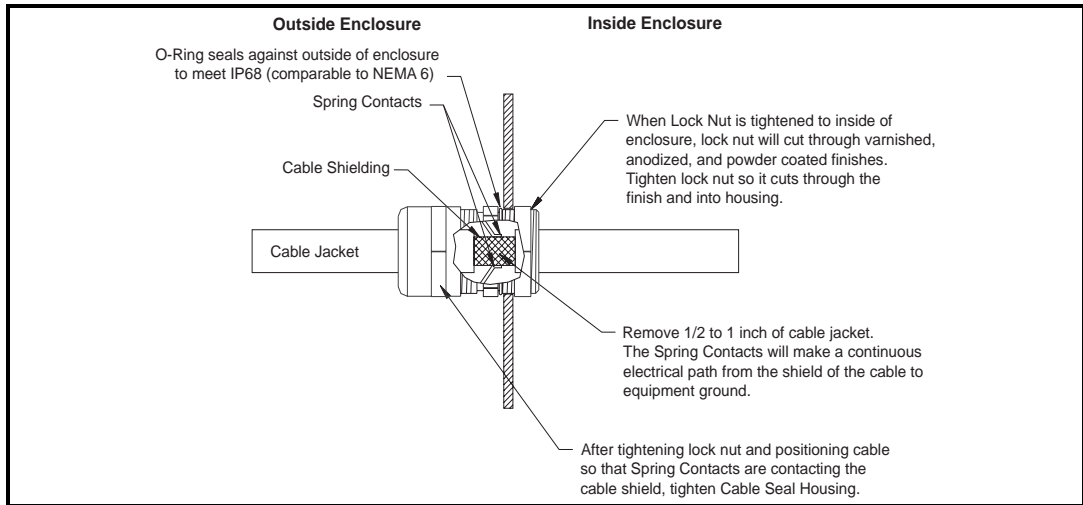

Figure 3: Through Wall Shield Grommet

Cable Type	Cable Model	Shielded Cable Grommet Kit Model	Actual Hole Size
Motor Cable, 18 Ga	XTMDS	CGS-047	0.8125 or 13/16"
Motor Cable, 16 Ga	CMDS	CGS-047	0.8125 or 13/16"
	4X16SS	CGS-047	0.8125 or 13/16"
Motor Cable, 18 Ga	XCMDs	CGS-047	0.8125 or 13/16"
Motor Cable, 12 Ga	CMMS	CGS-069	1.125 or 1 1/8"
	4X12SS	CGS-069	1.125 or 1 1/8"
Feedback Cable	CFOS	CGS-047	0.8125 or 13/16"
	MGFS	CGS-047	0.8125 or 13/16"
Flex Motor Cable, 16 Ga	CMDF	CGS-047	0.8125 or 13/16"
	4X16SF	CGS-047	0.8125 or 13/16"
Flex Motor Cable, 12 Ga	CMMF	CGS-069	1.125 or 1 1/8"
	4X12SF	CGS-069	1.125 or 1 1/8"
Flex Feedback Cable	CFCF	CGS-069	1.125 or 1 1/8"
	CFOF	CGS-069	1.125 or 1 1/8"
	MGFF	CGS-069	1.125 or 1 1/8"
External Encoder	ENCO	CGS-047	0.8125 or 13/16"
AC Power	user supplied	user supplied	user supplied

AC Line Filters

The AC line filters are necessary to comply with EMC emission and immunity standards. The drive was tested with the filters presented in the table below and recommended by Control Techniques.

Epsilon EP	Schaffner Part #	Control Techniques Part #	Rating
EP202, EP204	FN2070-10/06	960307-01	10 A, 240 V, 1 Ø
	FS5278-16/08	960305-01	16 A, 240 V, 1 Ø
EP206	FS5278-16/08	960305-01	

The following filters are a suitable alternative:

Epsilon EP	Part #	Rating
EP206	Schaffner FN 2070M-16/8	20 A, 240 V, 1 Ø
EP202, EP204, EP206	Corcom 20EQ1	
EP202	Schaffner FN 2070-6-06	6 A, 240 V, 1 Ø

AC Line Filter Installation Notes

- It is important to keep the filter inputs routed away from any electrical noise sources.
- EMC criteria can be met in installations where multiple drives are supplied through a single filter, however, it is the installers responsibility to verify EMC compliance.

Step 2: Mechanical Installation

The drive must be back mounted vertically on a metal mounting panel such as a NEMA enclosure, Additional space is necessary above and below the drive for wiring and cable connections.

To allow sufficient air flow for cooling, leave at least 0.25" [6.3 mm] clear space on vented cover (left) side plus 0.50" [12.7 mm] on heatsink (right) side. Leave additional space if cables are routed through this space.

WARNING

When drilling holes in mounting plate or trimming wires during installation of this or other equipment, do not allow drill shavings or wire trimmings to enter the EP drive. Such foreign objects can compromise electrical isolation creating a hazard or result in equipment failure.

The following table applies to the "A" dimension as shown in figure 4 below for the base and indexing drives.

Drive Model -B or -I only	Dimension "A" inches [mm]	Minimum Panel Width inches [mm]
EP202	2.11 [53.59]	2.90 [74]
EP204	2.11 [53.59]	2.90 [74]
EP206	2.82 [71.63]	3.60 [91]

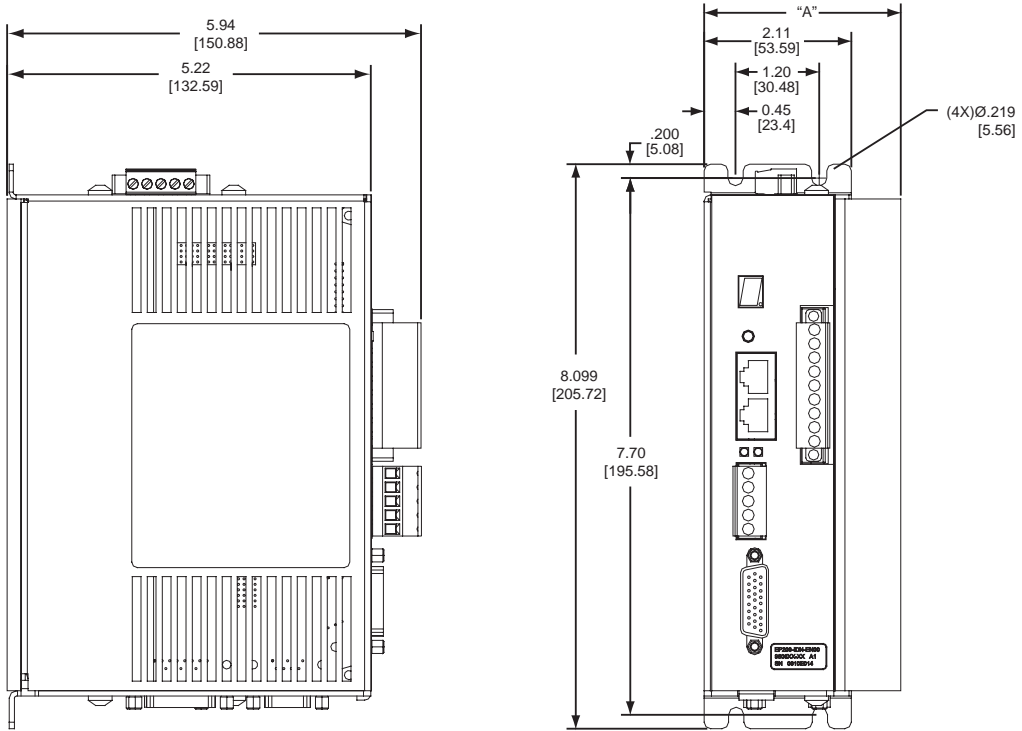

Figure 4: Mechanical Drawing for Epsilon Base and Indexing Drives

The following table applies to the "A" dimension as shown in figure 5 for the programming drives.

Drive Model	Dimension "A" inches [mm]	Minimum Panel Width inches [mm]
EP202-Pxx-xxxx	2.69 [68.3]	3.45 [88]
EP204-Pxx-xxxx	2.69 [68.3]	3.45 [88]
EP206-Pxx-xxxx	3.40 [86.4]	4.15 [105]

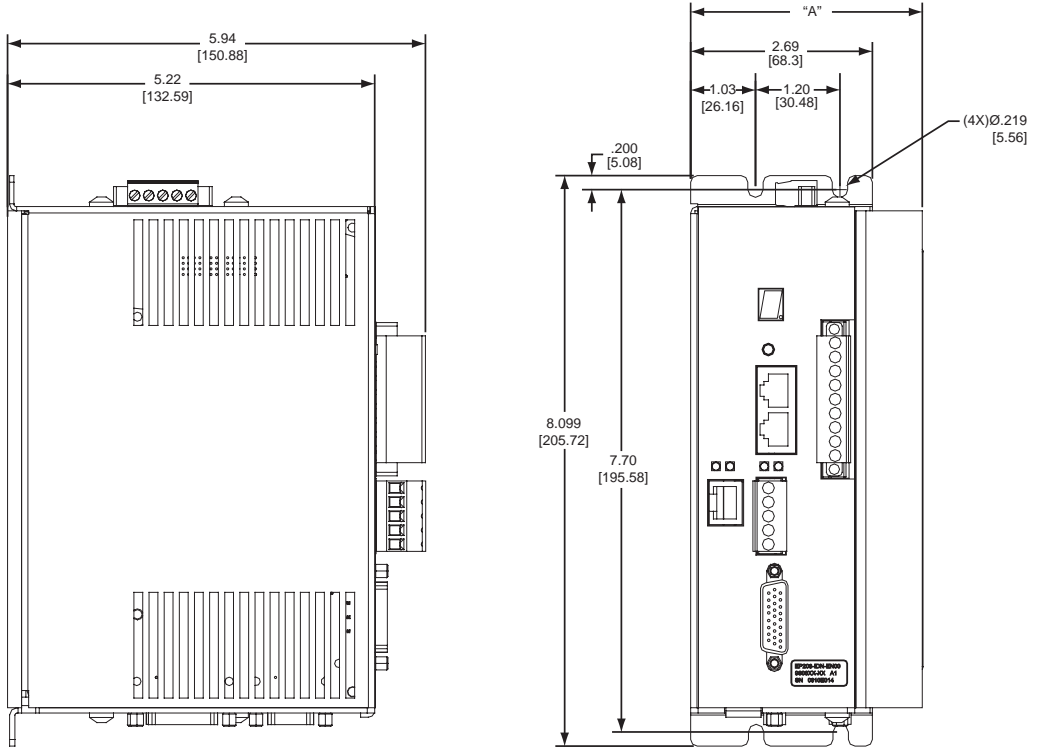

Figure 5: Mechanical Drawing for Epsilon Programming Drive

NOTE

To prevent drive from dropping out of position during installation, partially pre-install lower mounting screws, then set drive in place with lower mounting screws in slots and then install at least one upper mounting screw. For removal, loosen lower screws, remove upper screws and lift drive out.

Step 3: High Power Connections

System Grounding

To insure a safe and quiet electrical installation, good system grounding is imperative. The figure below is an overview of the recommended system grounding. For more information on achieving an electrically quiet installation refer to "Step 1: Basic Installation Guidelines" on page 3.

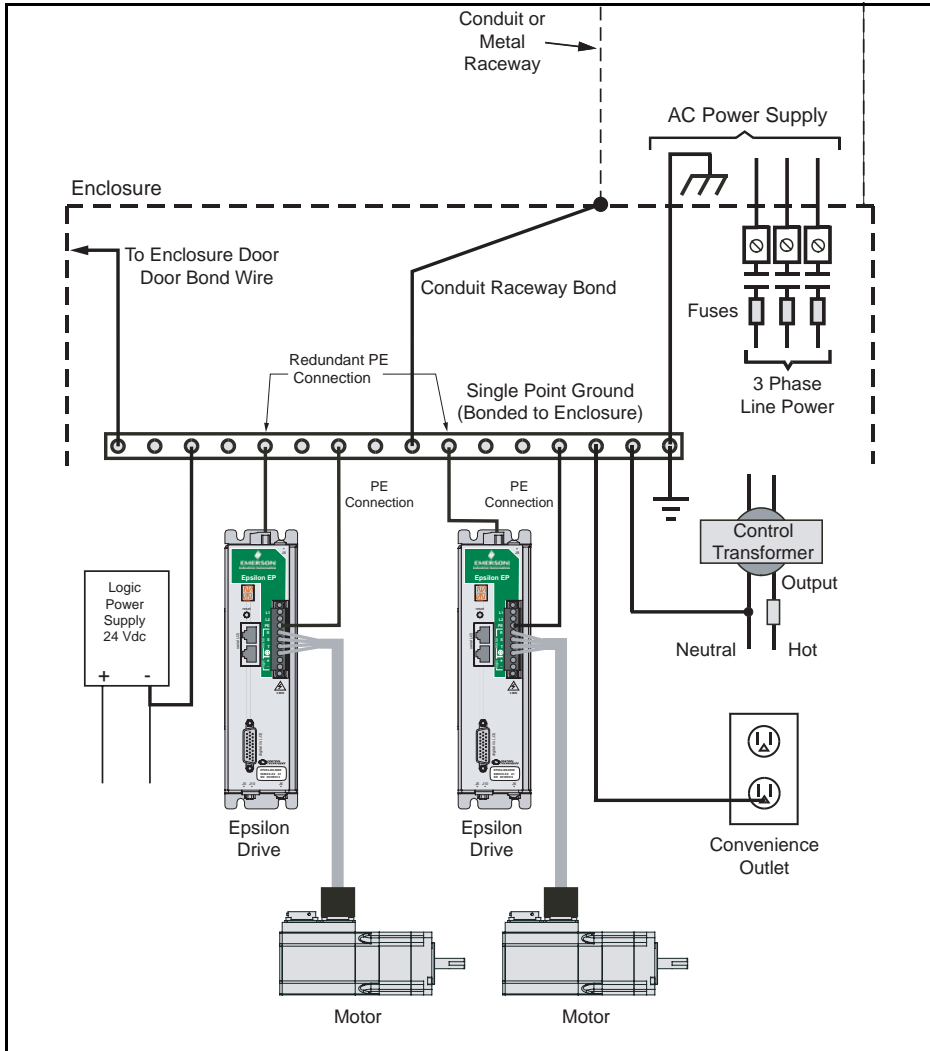

Figure 6: Typical System Grounding Diagram

⚠ WARNING

Fixed Protective Earth (PE) connections are mandatory for human safety and proper operation. These connections must not be fused or interrupted by any means. Failure to follow proper PE wiring can cause death or serious injury. This equipment has high earth leakage current and requires a redundant PE connection from either terminal marked PE at J8 to PE connection point.

AC Power Requirements

The Epsilon EP drives require 20 Vac to 264 Vac single phase power but, may operate on DC supplies, (See Operation on DC Supply). An Epsilon EP drive can be connected to any pair of power phases on a 1 Ø or 3 Ø power source that is grounded as shown in the following diagrams. Local electrical codes should be consulted before installation.

When operating the drive at 90 V or less disable the Low DC Bus fault so the drive does not fault.

⚠ WARNING

Where regeneration occurs, bus voltage will rise to 400 Vdc before shunt operation or a High DC Bus fault limit voltage, whether shunt resistor is installed or not. Motors must have insulation rated for inverter duty at 240 Vac no matter what the operating voltage is, or bus voltage must be limited by other means.

NOTE

The maximum voltage applied to the drive terminals must not exceed 264 Vac phase to phase and phase to PE ground. The AC supply must be earthed (type TN) with PE connected to the earthed point at the source, which is usually a distribution transformer but could be a service entrance.

AC Supplies NOT Requiring Transformers

If the distribution transformer is configured as shown in the figures below, the AC power supply can be connected directly to the drive terminals.

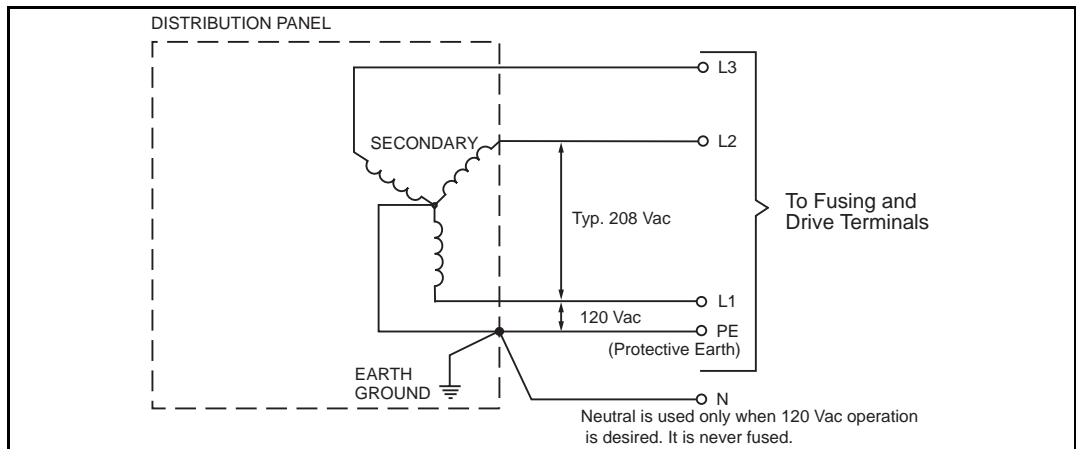

Figure 7: Earth Grounded WYE Distribution Transformer, 120/208Y 3Ø

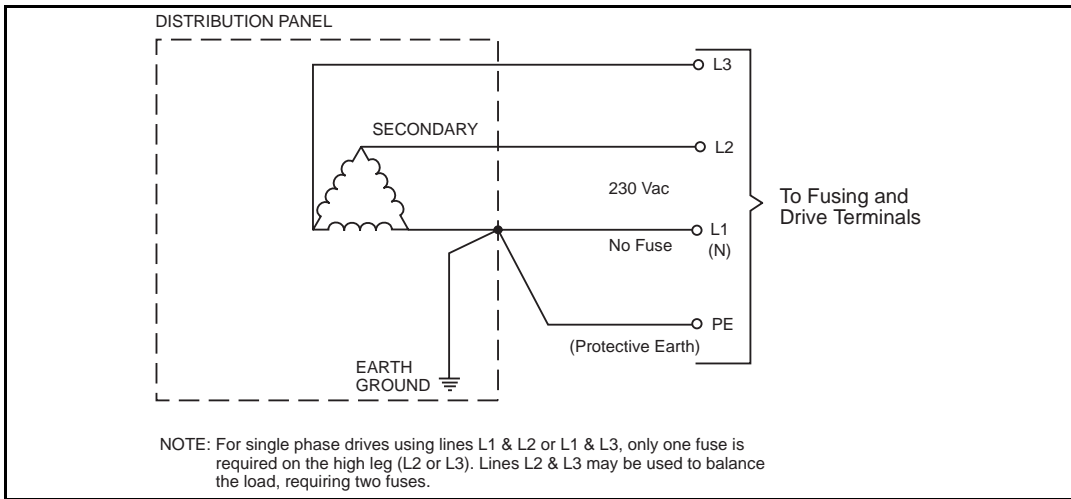

Figure 8: Earth Grounded Delta Distribution Transformer, 240 Vac 3Ø

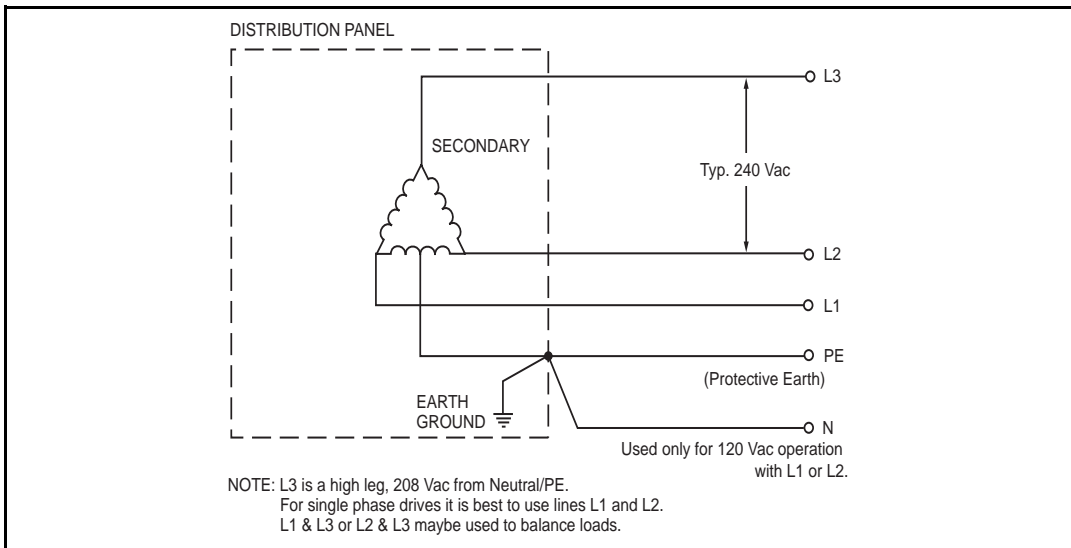

Figure 9: Three Phase Delta (with mid-phase GND) Distribution, 120 Vac split/240 Vac 3Ø supply

AC Supplies Requiring Transformers

If the distribution transformer is configured as shown in the figures below, an isolation transformer is required. If an isolation transformer is used between the power distribution point and the drives, the transformer secondary must be grounded for safety reasons as shown in the figures below.

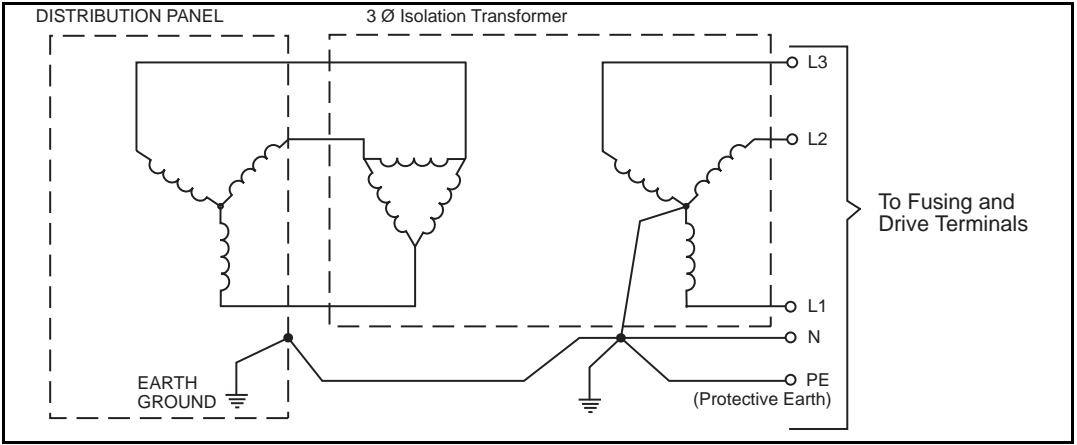

Figure 10: *Three-Phase WYE (ungrounded) Distribution to a Three-Phase Delta/WYE Isolation Transformer*

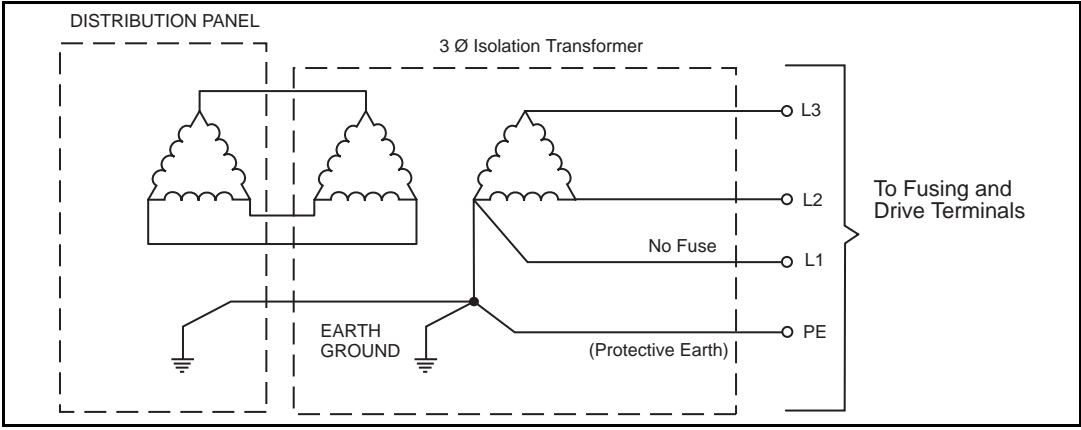

Figure 11: *Three-Phase Delta (ungrounded) Distribution to a Three-Phase Delta Isolation Transformer*

When multiple drives are connected to a single isolation transformer, add the suggested KVA ratings of the drives that would be operating simultaneously together for transformer sizing.

Drive/Motor Combination	Suggested KVA Rating
EP202/NT-207	1.2
EP202/NT-212	1.2
EP204/NT-207	1.2
EP204/NT-212	1.7
EP206/NT-212	1.7
EP206/NT-320	3.0
EP206/NT-330	3.0
EP206/NT-345	3.0
EP202/XV-402	0.2
EP202/XV-403	0.3
EP202/XV-604	0.8
EP202/XV-606	0.8
EP204/XV-6011	1.3
EP204/XV-8017	2.0
EP204/XV-8022	2.2
EP204/XV-8023	2.1
EP206/XV-8014	2.0
EP206/XV-8022	2.2
EP206/XV-8023	2.1
EP206/XV-8028	2.6
EP206/XV-13046	3.3
EP206/XV-13051	2.1
EP206/XV-13089	3.6

Line Fusing and Wire Size

You must incorporate over current protection for the incoming AC power with the rating shown here.

NOTE

UL approval for operation with the circuit breakers identified in the table below is pending. At present, fuses shown must be used for installation to meet UL.

Drive Model	Recommended Minimum AC/PE Line Wire Gauge	Fuse			Miniature Circuit Breaker	
		Fuse Class & Action	Bussman	Ferraz-Shawmut	Allen Bradley	Square D
EP202	16 AWG ISO 1,5	RK1 Time-Delay	LPN-RK-6SP	A2D6R	1489-A1D060 6 A, 1 pole	60124 6 A, 1 pole
		RK1 Quick-Acting	KTN-R-6	A2K6R		
		CC Time-Delay	LP-CC-6	ATDR6	1489-A2 D060 6 A, 2 pole	60158 6 A, 2 pole
		CC Quick-Acting	KTK-R-6	ATMR6		
EP204	16 AWG ISO 1,5	RK1 Time-Delay	LPN-RK-10SP	A2D10R	1489-A1D100 10 A, 1 pole	60127 10 A, 1 pole
		RK1 Quick-Acting	KTN-R-10	A2K10R		
		CC Time-Delay	LP-CC-10	ATDR10	1489-A2D100 10 A, 2 pole	60161 10 A, 2 pole
		CC Quick-Acting	KTK-R-10	ATMR10		
EP206	14 AWG ISO 2,5	RK1 Time-Delay	LPN-RK-15SP	A2D15R	1489-A1D150 15 A, 1 pole	60129 15 A, 1 pole
		RK1 Quick-Acting	KTN-R-15	A2K15R		
		CC Time-Delay	LP-CC-15	ATDR15	1489-A2D150 15 A, 2 pole	60263 15 A, 2 pole
		CC Quick-Acting	KTK-R-15	ATMR15		

Use copper conductors only. Conductors must be rated 75°C or higher, preferably 90°C.

WARNING

The Protective Earth (PE) wire connection is mandatory for human safety and proper operation. This connection must not be fused or interrupted by any means. Failure to follow proper PE wiring can cause death or serious injury.

Drive Model	Input Voltage (Vac)	Frequency (Hz)	Input Current (Amps RMS) at Full Drive Output Current	Inrush Current (Amps)
EP202	240 / 1 Ø	47 - 63	5.0	40 (5 ms)
EP204			8.5	65 (5 ms)
EP206			12.0	100 (5 ms)

This inrush current specification assumes the drive has been powered off for at least 8 minutes at 40°C (104°F) ambient or 5 minutes at 25°C (77°F) ambient. If this amount of time has not elapsed since power off, the inrush current will be higher.

AC Input Power Connections

⚠ WARNING

Power must be "Off" for a minimum of 6 minutes for the Epsilon EP206 drive and 3 minutes for the Epsilon EP202/204 drives before unplugging the power connection. This will ensure the bus voltage has bled down to a safe level (below 50 Vdc).

⚠ CAUTION

Do not connect or disconnect AC power by inserting or removing the AC power connector. Using the connector in this manner, even once, will damage the connector making it unusable.

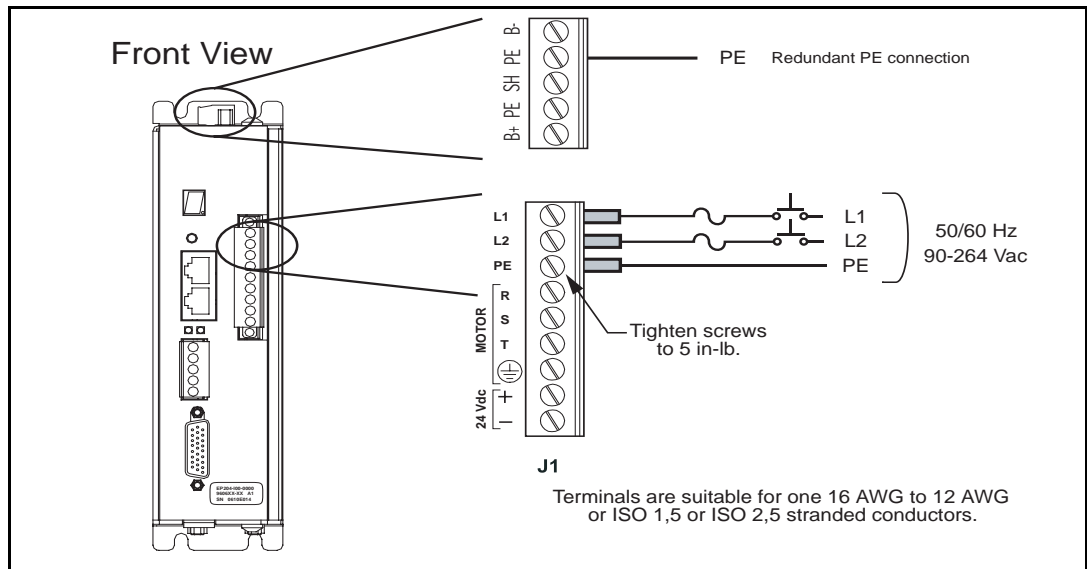

Figure 14: Epsilon EP AC Power Wiring Diagram

Operation on DC Input Supply

At this time, the EP drive is not UL listed for operation on a DC input supply.

The EP drive can operate on DC input as low as 10 Vdc, though recommended minimum is 24 Vdc. It can also operate from a common DC link with voltage to 373 Vdc, the voltage resulting from 264 Vac applied to a rectifier, with regen to 400 Vdc intermittently.

For DC input supply less than 24 Vdc, the DC input should be connected to the B+ and B- terminals at J8 to avoid losses in the rectifier and inrush limiter. At such low voltages the bus caps do not need inrush protection. For DC supply greater than 24 Vdc, the supply should be connected to L1 and L2 terminals on J1. Polarity does not matter. The rectifier blocks reverse current so regen energy will not come back to the supply. DC supply greater than 24 Vdc may be applied to the B+ and B- terminals of J8, but the supply must provide soft-start or inrush current limiting and must be able to handle any anticipated regen energy.

Both supply conductors must be fused except one that is grounded. The fuse must be rated for at least the voltage applied. The current rating of the fuse should match the rated output current of the drive. A slow-blow fuse should be used if high peak loads are expected.

External Shunt Electrical Installation

WARNING

Shunt connections at J8 remain at dangerous Voltages after disconnecting AC Power. Power must be "Off" for a minimum of 6 minutes for an EP206 and 3 minutes for an EP202/204 before touching these terminals.

The EP204 and EP206 drives provide an internal shunt transistor to direct regen energy to an external shunt or braking resistor. The resistor is connected to the B+ and SH terminals at J8 on the top of the drive.

Shunt Control

The shunt transistor turns on when the bus voltage reaches 405 Vdc and shuts off when the bus voltage falls below 390 Vdc. An internal shunt control algorithm is used to prevent the external shunt resistor from overloading. It is necessary to enter shunt energy rating, power rating and resistance for the attached shunt resistor in PowerTools Pro software. Energy rating is the amount of energy that the resistor can absorb in a single shunt event assumed to be so short that power dissipation is negligible. Power rating is the long term average power that can be dissipated. PowerTools Pro default values are for the Control Techniques "SM-Heatsink DBR-1" resistor kit, marked P/N 1220-2756-01 on the resistor.

External Shunt Resistor

Control Techniques offers an external shunt resistor kit, SM-Heatsink DBR-1, that attaches directly to the EP drive heatsink. The resistance is 75 Ohms and has 1500 Joule energy rating and 50 W continuous power rating. It is adequate for most infrequent machine stop sequences due to relatively high energy rating for its power rating. It should be suitable for any EP204 application unless average power exceeds 50 W for repetitive cycles. For an EP206, some applications may require lower resistance to prevent a high bus fault or higher energy rating for a single event, as well as higher average power rating. The resistor in the kit is designed to eventually open in the event of a shorted control transistor when operating with an AC input greater than 200 Vac. At this time the kit should be used only when the drive is operating at 200 Vac to 240 Vac.

A different external shunt resistor should be used if average power is above 50 W, or other limits are exceeded as described above. Higher power resistors should be mounted away from the drive to prevent overheating. If thermal loading inside a cabinet is an issue, a resistor with suitable enclosure may be installed external to the drive enclosure. The minimum resistance for an external shunt resistor is 33 Ohms. The resistor must have thermal overload protection to remove power in the event of a shorted control transistor. The protection can simply open the circuit, in which case a high bus fault will occur, or be wired to a contactor that isolates input power from the drive on overtemp.

Shunt Resistor Kit Installation

The SM-Heatsink DBR-1 attaches to the side of an EP204 or EP206 drive by lining up the two captive screws to the special width slots in the heat sink. The exact position along the slot does not matter as long as the body of the resistor does not extend beyond the top or bottom of the drive. Use a T-20 Torx driver to thread the screws into position. After both are well started but not tight, carefully turn each screw until it is seated against the resistor and the resistor back is seated against the heat sink. Then turn the screw 1/8 turn more. Do not overtighten.

Strip 0.12 inch [3.0 mm] insulation from the ends of the resistor wires. Install the wires in the SH and B+ terminals of J8 and tighten to 5 in-lb. Make sure the locking screws are installed on J8 to prevent the connector from pulling out.

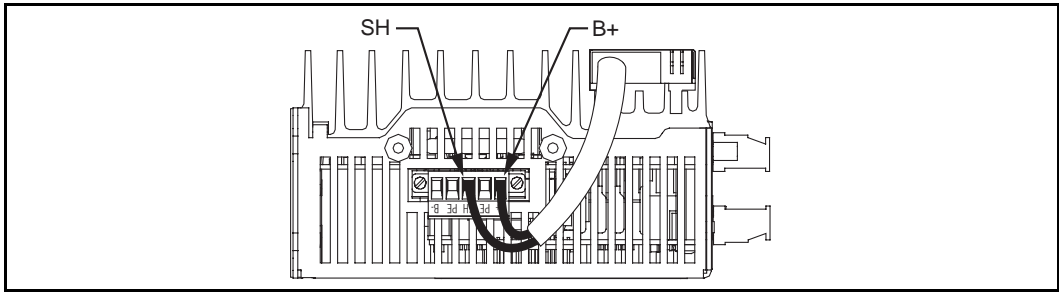

Figure 15: Shunt Resistor Connections showing SM-Heatsink DBR-1 Kit

⚠ CAUTION

Do Not make any shunt resistor connections to B-.

⚠ WARNING

Shunt connections are at main voltage potential. Components connected must be rated for the voltage and selected for safety. The external shunt resistor must have protection for a failed ON state of the shunt control.

Motor Power Wiring

The following paragraphs provide details of motor connections. When motor power cables are long, 100ft. [30 m], a ferrite (Control Techniques p/n 157016-13, Steward p/n 28A3851-0A2 or equivalent) installed on the three phase conductors but not the shield, near J1 can significantly reduce high frequency switching harmonics that in some cases can cause communications errors. Maximum cable length is 200 ft [60 m]. J1 terminals are suitable for one 18 AWG to 14 AWG or ISO 0,75 to ISO 2,5 stranded conductors. The ground/shield terminal may contain the shield and ground conductors together if each is 16 AWG or ISO 0,75 or ISO 1,5. Otherwise a ferrule must be used to crimp both connectors together.

NT and MG Motors

NT and MG motors are equipped with up to three male MS (Military Standard) connectors, one for stator connections, one for encoder connections and one for the brake (if so equipped).

Stator connections from the drive to the motor are made with the CMDS or CMMS cable have a female MS style connector on the motor end and four individual wires and shield that connect to the motor power connector on the front of the drive.

NOTE

The motor ground wire and shields must be run all the way back to the drive terminal and must not be connected to any other conductor, shield or ground except the enclosure wall for EMC.

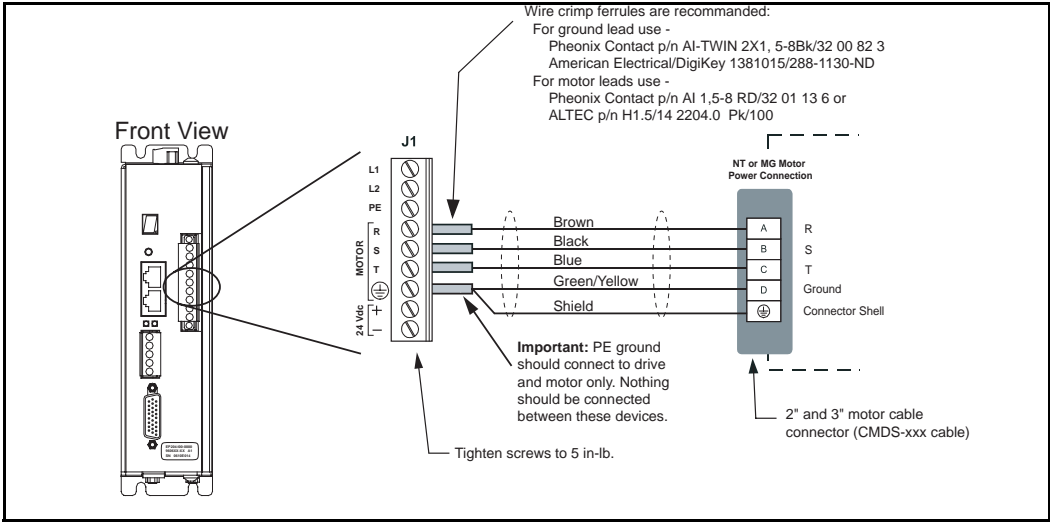

Figure 16: Epsilon EP - NT/MG Motor Power Wiring Diagram

XV Motor Power Wiring

The XV 40 mm to 80 mm motors are equipped with up to three connectors, one for stator connections, one for encoder connections and one for the brake (if so equipped).

Stator connections from the drive to the motor are made using the XTMSD cable, the motor end of the cable has an Amp "Mate-N-Lok"® connector and the drive end has four individual wires and shield that connect to the motor power connector on the front of the drive.

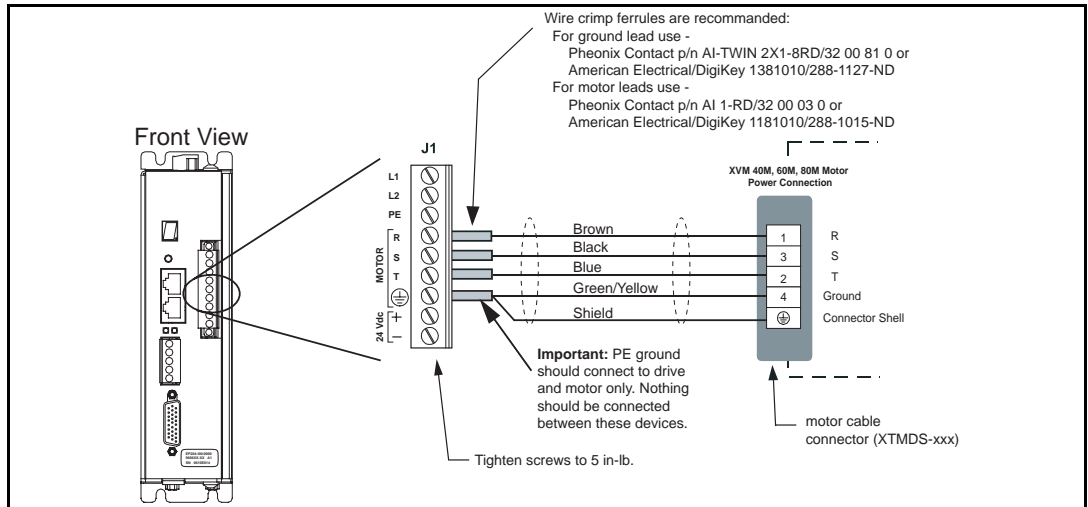

Figure 17: Epsilon EP - XV 40 mm - 80 mm Motor Power Wiring Diagram

The XV 130 mm motors have two MS (Military Standard) connectors, one for the stator connections and one for the encoder connections. Stator connections from the drive to the motor are made with the XCMDS (motor without brake) or the XCMDBS (motor with brake) cable.

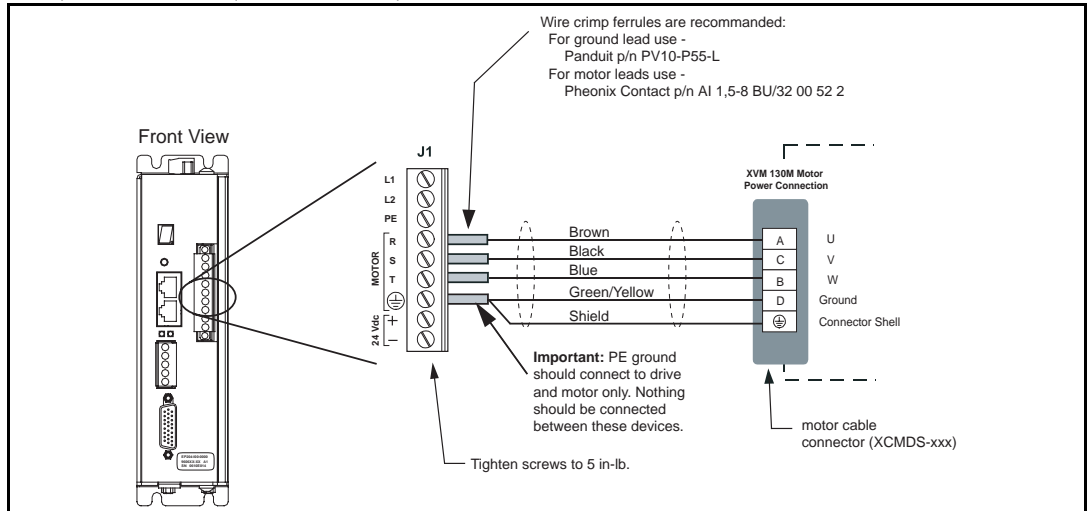

Figure 18: Epsilon EP - XV 130 mm Motor Power Wiring Diagram

Step 4: Low Power Connections

DC Logic Power Supply Wiring

The Epsilon drive requires a user supplied logic power supply, 24 Vdc $\pm 10\%$, to power the internal logic of the drive. Use the table below to determine the current requirements of the application. Users should consider keeping logic power energized at all times because it helps prevent condensation and maintains position information in the drive.

Logic Power Supply Specification

Voltage Range	Model	Current
24 Vdc $\pm 10\%$ (21.6 Vdc to 26.4 Vdc)	EP-P	050 A without sync encoder 0.57 A with 250 mA sync encoder
	All EP Models except EP-P	0.31 A without sync encoder 0.38 A with 250 mA sync encoder

CAUTION

Do not wire AC line into the logic power supply input. Doing so will damage the drive.

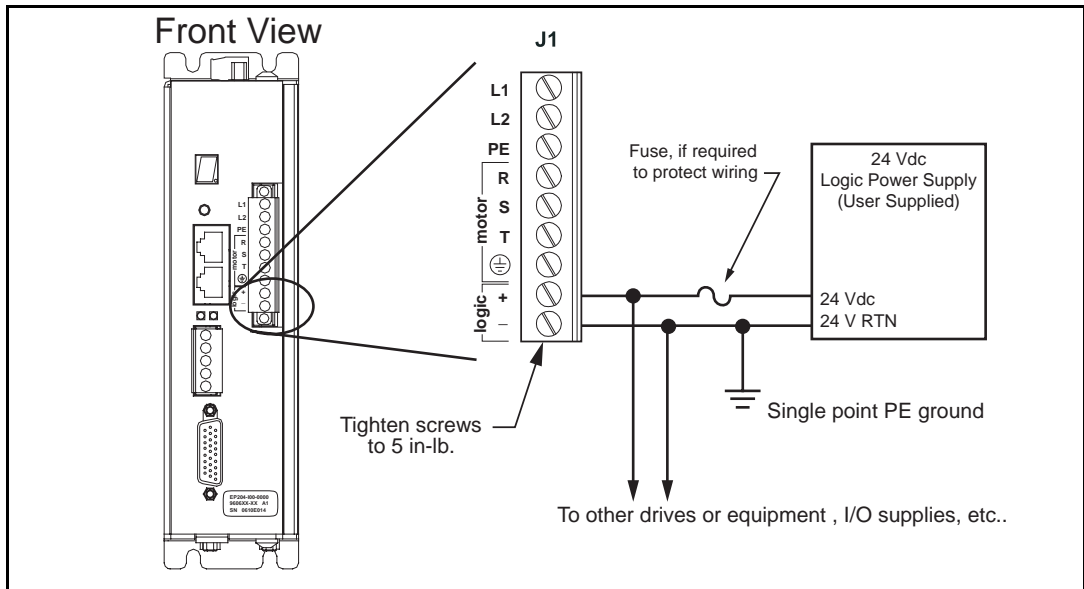

Figure 19: Logic Power Supply Wiring Diagram

For UL applications, the logic power supply must be a UL recognized or UL listed limited voltage/limited energy or limited voltage/limited current supply, or a limited voltage supply with overcurrent protection appropriate for the wiring and not to exceed 12 A. Isolate line connected circuits from low voltage circuits.

For applications to meet the EU Low Voltage Directive, an approved 24V supply must be used and the negative side must be grounded to PE. PELV circuits must have protective separation for 300 V system voltage from mains connected circuits, including separation between encoder circuits and motor power wiring. If all circuits connected

to the logic supply are PELV, the wiring need not be isolated from direct contact within a zone of equipotential bonding, normally an enclosure or set of enclosures bonded together. Otherwise, logic wiring and circuits must be isolated from direct contact by basic insulation for 300 V system voltage.

In all applications, do not interconnect extra low voltage power supplies so that voltages add.

Motor Feedback Wiring (J6)

Encoder feedback connections are made with the 15-pin high density "D" connector (J6) on the drive. Maximum feedback cable length is 200 ft [60 m].

Connection of Encoder Quadrature and Marker Signals

For A, A/, B, B/ and Z, Z/ pairs, Control Techniques cables use low capacitance (~10 pF/ft) wire to get a high characteristic impedance and low loss. The differential input circuit accepts RS-485 level signals, but if the differential voltage is less than ± 400 mV, an encoder fault is generated.

Connection of Encoder Commutation Signals to the Drive

The drive is capable of receiving U, V, and W commutation signals from either a differential or single ended source. Figures 20 through 22 show a simplified circuit for the U, U/, V, V/, W, and W/ inputs on the drive. For single-ended encoder outputs, leave U/, V/, and W/ unconnected at the drive. No PowerTools configuration is required. U, V, and W have a 1K pull-up to 5V. Logic threshold is about 2.5 V with 0.1 V hysteresis.

Motor Overtemp Wiring

The motor overtemp circuit is compatible with PTC thermistor sensor with 1K resistance at the over temperature trip point. The circuit provides 5V open circuit and 0.5 mA closed contacts to an overload switch. For motors without over temperature protection sensors, pins 14 and 15 of J6 must be shorted together to prevent an overtemp fault in the drive.

NT/MG Motor

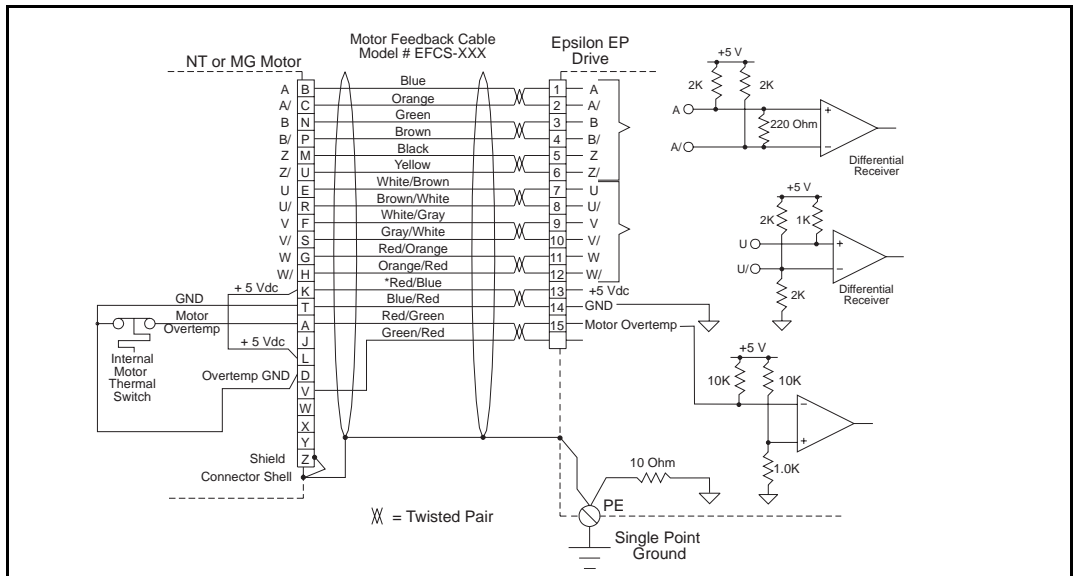

Figure 20: Motor Encoder Feedback Connector Pinout

XV 40-80 mm Motor

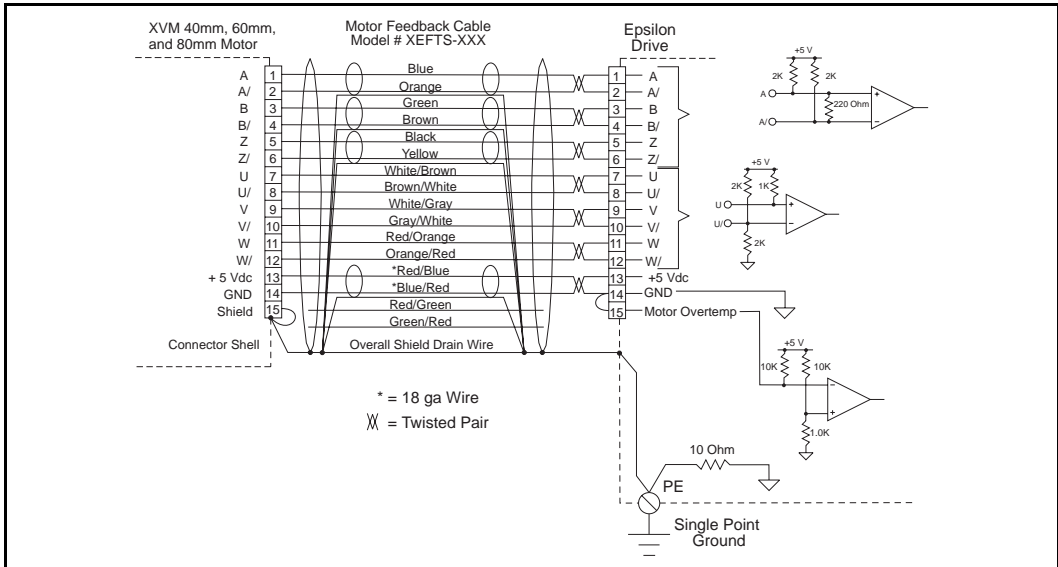

Figure 21: Motor Encoder Feedback Connection For XV 40-80 mm Motors

XV 130 mm Motor

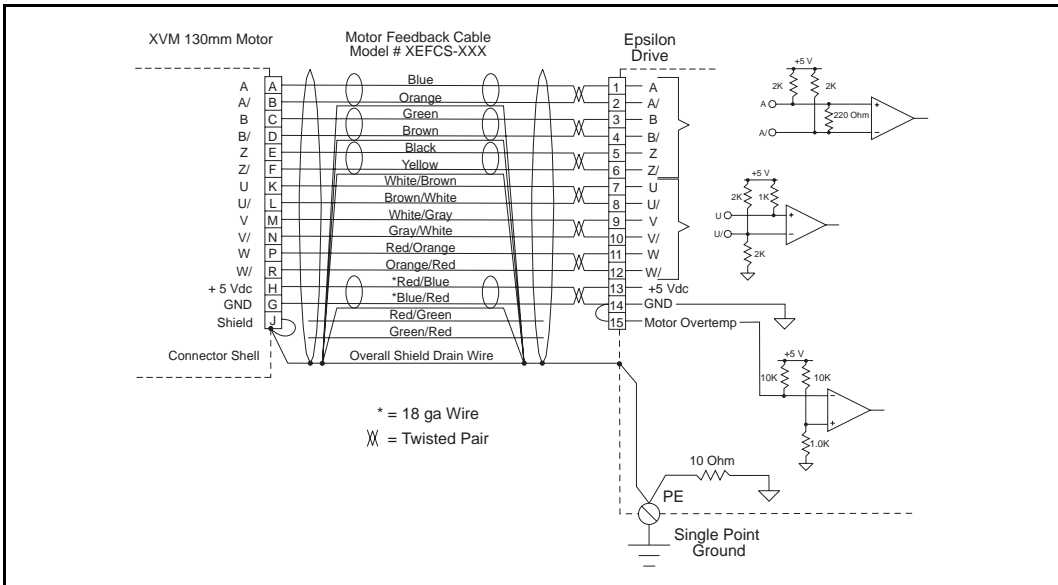

Figure 22: Motor Encoder Feedback Connection For XV 130 mm Motors

Motor Brake Wiring

The NT and MG motors equipped with brakes have a three-pin MS style connector. The brake power cable (model CBMS-XXX) has an MS style connector on the motor end and three wire leads on the drive end (see the following wiring diagrams). The XV 40-80 mm motors with brakes have a two-position connector. The brake power cable (model XTBMS-XXX) has a two position connector on the motor end and three wire leads on the drive end. The XV 130 mm motors equipped with brakes have two MS style connectors; one is the encoder feedback and the other has the motor power and brake connections. The motor power/brake cable (model XCMDBS-XXX) has an MS style connector on the motor end and six wire leads on the drive end.

You must provide a DC power supply rated at +24 Vdc with a 2 A minimum current capacity for the brake. If you use this voltage source to power other accessories such as I/O or more than one brake, size the power supply for total load.

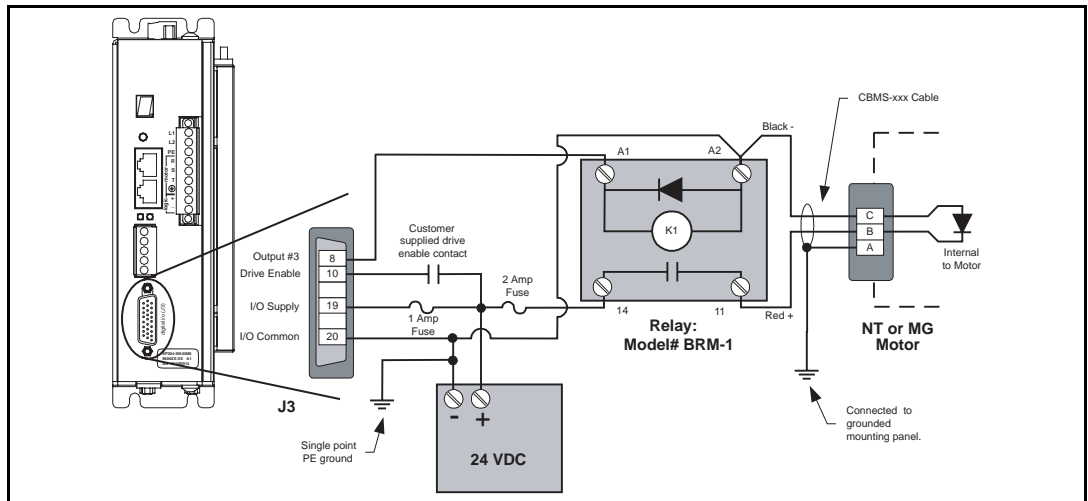

Figure 23: Epsilon EP to NT or MG Motor Brake Wiring Diagram

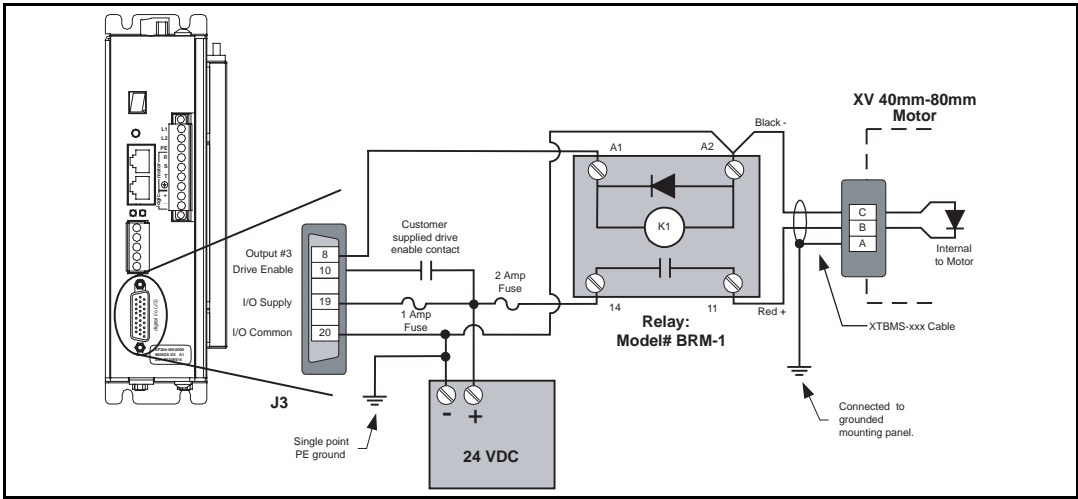

Figure 24: Epsilon EP/XV 40-80 mm Motor Brake Wiring Diagram

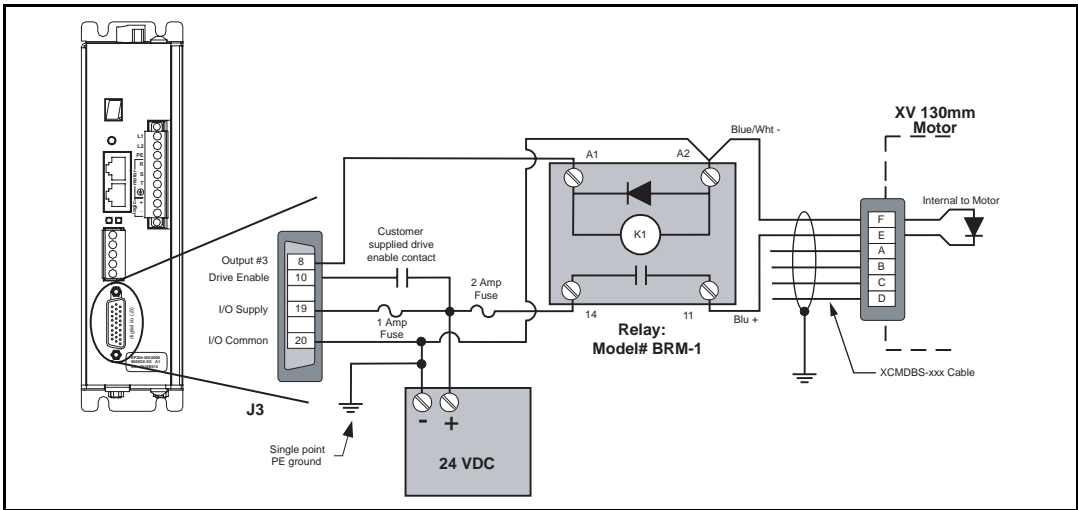

Figure 25: Epsilon EP/XV 130 mm Motor Brake Wiring Diagram using the I/O Connector

Input/Output and Drive Enable Wiring

The Epsilon EP-B drive is equipped with 5 optically isolated input lines (one is dedicated to a drive enable function) and 3 optically isolated output lines. The Epsilon EP-I, EP-IDN and EP-P drives are equipped with 16 optically isolated input lines (one is dedicated to a drive enable function) and 8 optically isolated output lines. All inputs and outputs are configured as sourcing; that is, the outputs "source" current from the positive side of the I/O supply when ON and the inputs are compatible with a sourcing output returning current to the grounded negative side of the I/O supply.

Inputs are ON with +10 Vdc to +30 Vdc applied and OFF when less than +1.5 Vdc or 0.2 mA is applied. Input current at 24 Vdc is 4.8 mA and input resistance is about 4.8k ohms.

Maximum load on each output channel is 150 mA with 3.5 Vdc max voltage drop from I/O supply + to output. Outputs are rugged and require no freewheeling diode on inductive loads. Outputs are short-circuit proof to ground (0 V) or any voltage from 0V to the I/O power supply voltage.

Optical isolation for I/O is functional only and does not provide safety rated isolation. I/O circuits must be PELV for any extra low voltage circuits to be PELV. For UL installations, I/O wiring must be from a limited voltage/limited energy or limited voltage.limited current supply.

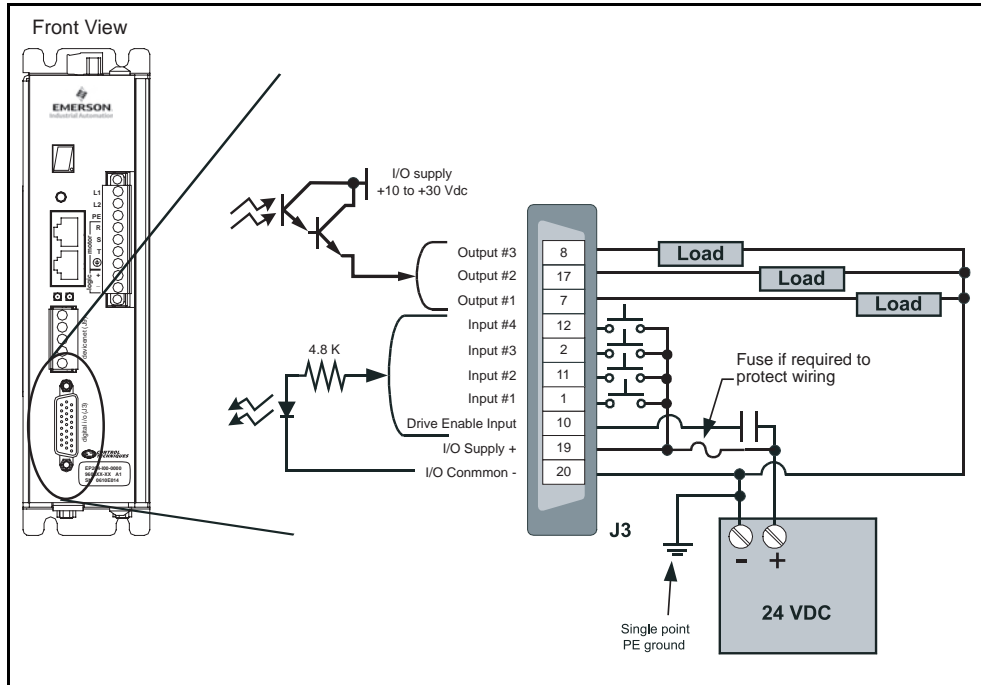

Figure 26: Epsilon EP-B Input/Output Wiring Diagram

As part of PELV wiring, I/O circuits are intended to be used within a zone of equipotential bonding where cables or wiring would typically be no more than 10 ft [3 m] long. These circuits have not been evaluated for EMC immunity which would be required for longer cables.

I/O Connector (J3) Functions

The I/O connector is a 26-pin male high-density dsb connector on the front of the drive. A low profile standard terminal interface board (STI-24IO) and cable assembly (EIO26-xxx) are available for making connections convenient. Figure 26 shows pin-outs for I/O channels supported in the EP-B drive and for external wiring typical of all I/O channels. Figure 27 shows pin-outs for EP-I and EP-P models. Input channels 1-8 have high speed capture capability in the EP-P models. Figure 28 shows the STI-24IO interface board for discrete wiring to I/O.

J3 Connector Pin#	Function
1	Input Line 1
2	Input Line 3
3	Input Line 5
4	Input Line 7
5	Input Line 9
6	Input Line 11
7	Output Line 1
8	Output Line 3
9	Output Line 5
10	Enable
11	Input Line 2
12	Input Line 4
13	Input Line 6
14	Input Line 8
15	Input Line 10
16	Input Line 12
17	Output Line 2
18	Output Line 4
19	I/O +V
20	I/O Common
21	Output Line 8
22	Input Line 13
23	Input Line 14
24	Input Line 15
25	Output Line 6
26	Output Line 7

Figure 27: I/O Connector (J3) Functions

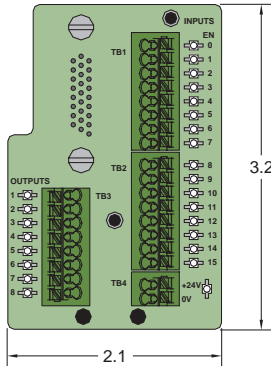

Figure 28: STI-24IO Interface Board

Analog/Sync Output Connector (J5)

All command, diagnostic, and sync signals are available using the 15-pin Analog/Sync Output connector. If interfacing the drive using field wiring, the optional standard terminal interface board (STI-SNCOA) may be used. It provides convenient connections using screw terminal strips.

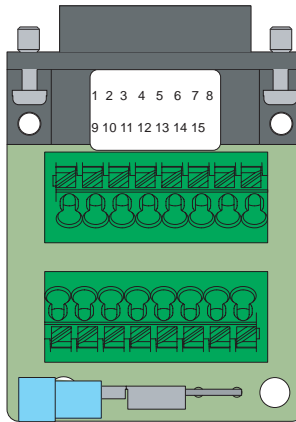

Figure 29: STI-SNCOA

J5 Connector Pin#	Function
1	Motor Encoder A
2	Motor Encoder B
3	Motor Encoder Z
4	Pulse
5	Analog Input +
6	Analog Ground
7	Analog Output 1
8	Logic Common
9	Motor Encoder A/
10	Motor Encoder B/
11	Motor Encoder Z/
12	Direction
13	Analog Input -
14	Analog Ground
15	Analog Output 2

Figure 30: Analog/Sync Output Connector (J5) Functions

Function	Pin Numbers	Electrical Characteristics
Encoder Out	1, 2, 3, 9, 10, 11	Differential line driver output (RS 422)
Diagnostic Output	7, 15	± 10 Vdc 10 mA maximum analog diagnostic, ref. to pins 6 and 14
Diagnostic Output Common	6, 14	0.0 V, 10 ohms away from PE. 0 ohms away Logic Common (pin 8)
Pulse In	4	Single ended pulse input
Direction	12	Single ended direction input
Analog Command	5, 13	Differential; Analog Command Input

As part of PELV wiring, circuits at J5 are intended to be used within a zone of equipotential bonding where cables or wiring would typically be no more than 10 ft [3 m] long. These circuits have not been evaluated for EMC immunity which would be required for longer cables.

Sync Input Connector (J10)

Sync Input signals are connected to the drive using the 9-pin Sync Input connector.

If interfacing the drive using field wiring, the optional standard terminal interface board (STI-SNCI) may be used.

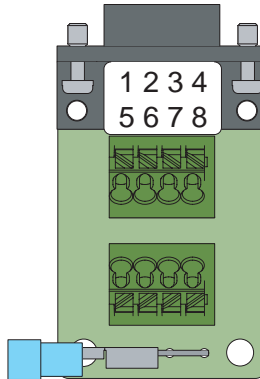

Figure 31: STI-SNCI Interface Board

J10 Connector Pin#	Function
1	Encoder A
2	Encoder A/
3	Encoder B
4	+ 5 Vdc
5	Encoder B/
6	Encoder Z
7	Encoder Z/
8	Logic Common
9	NC

Figure 32: Analog Input Connector (J10) Functions

Function	Pin Number	Electrical Characteristics
Encoder In	1, 2, 3, 5, 6, 7	Differential line driver input (RS 422)
5 Vdc	4	+5 Vdc supply voltage
Ground	8	Logic Common

The Sync Input power meets EMC emissions and immunity for cables longer than 3 meters [10 ft], when using a shielded cable. When a remote encoder is user, cable length may be limited by encoder supply voltage drop, and should not exceed 200 ft [60 m].

Analog Command Wiring

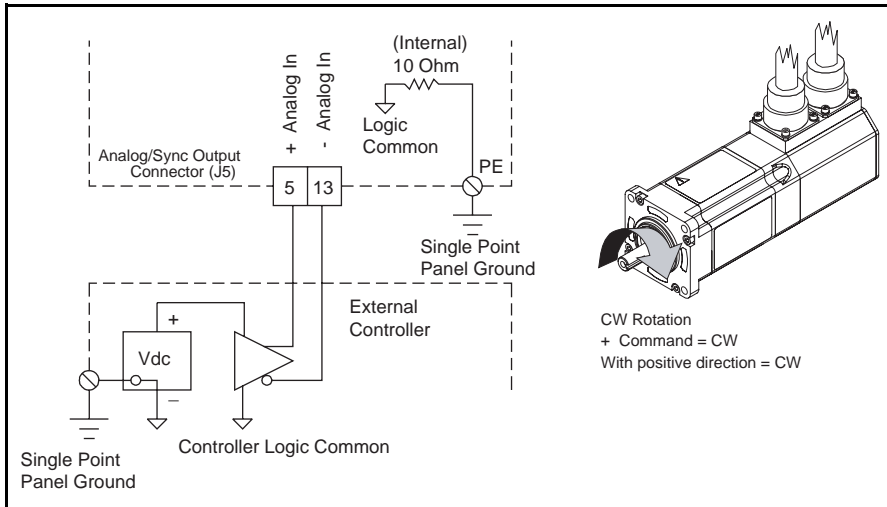

Figure 33: Analog Command, Differential Wiring Diagram

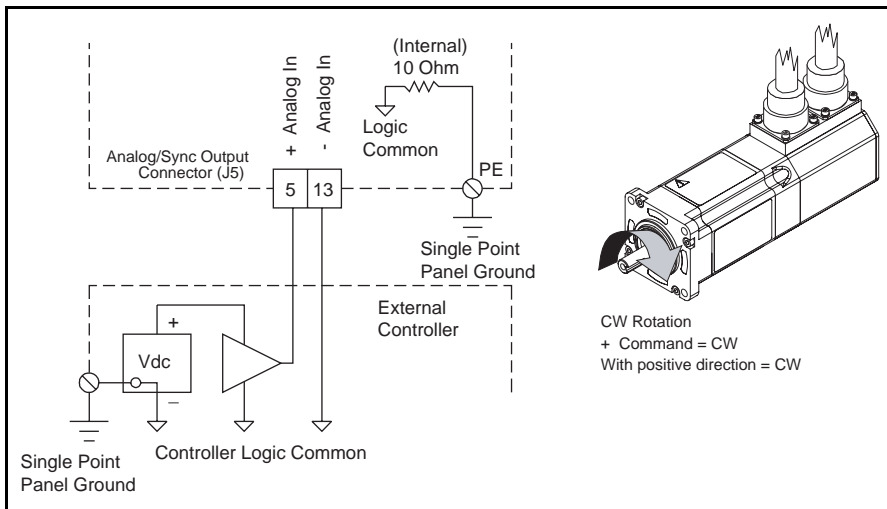

Figure 34: Analog Command, Single Ended Wiring Diagram

Encoder Output Signal Wiring

The encoder outputs meet RS-422 line driver specifications and can drive up to ten RS-422 signal receivers.

The default encoder output scaling is set to output the actual motor encoder resolutions. The standard MG and NT motors have 2048 lines per revolution. With PowerTools Pro software this resolution is adjustable in one line per revolution increments up to the density of the encoder in the motor.

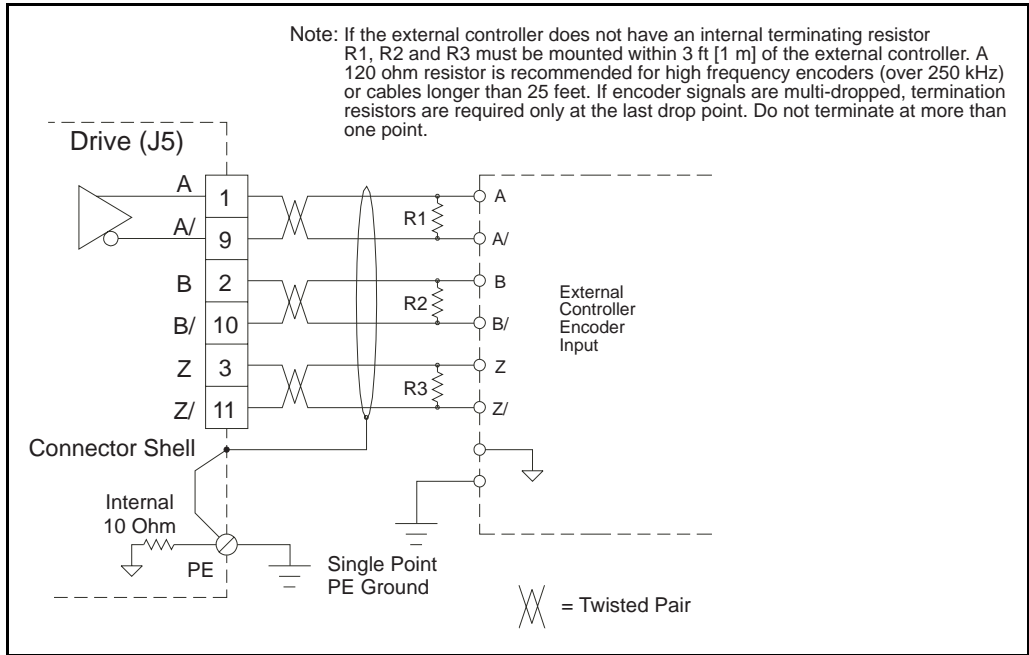

Figure 35: Analog/Sync Output Connector (J5) Encoder Output Wiring

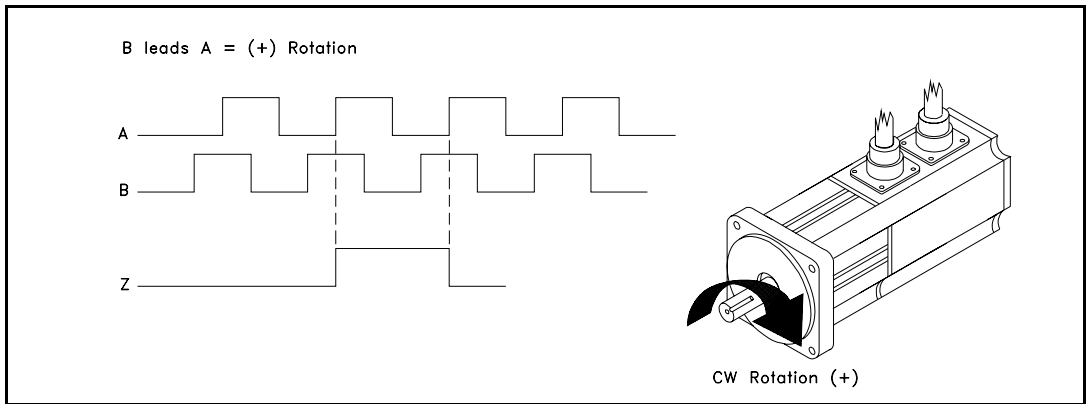

Figure 36: Direction Convention Diagram

Pulse Mode Wiring, Differential Inputs

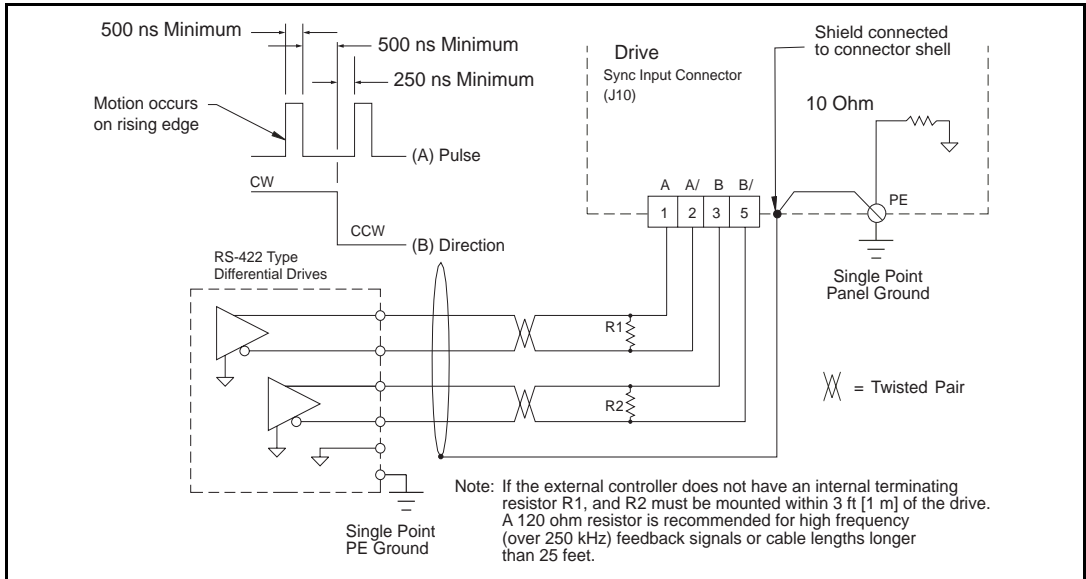

Figure 37: Pulse Mode, Differential Output to Differential Input

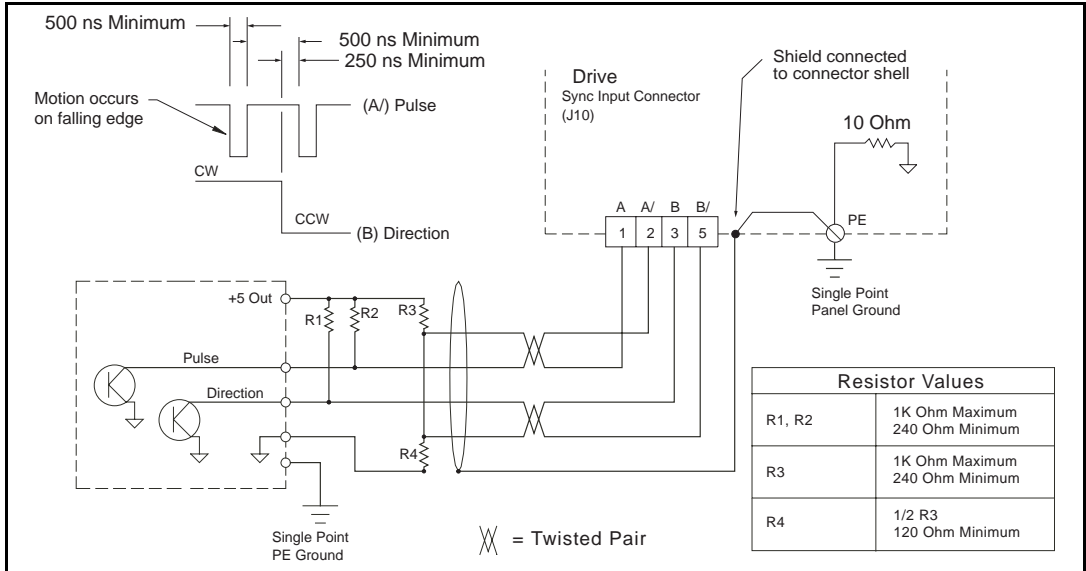

Figure 38: Pulse Mode, Single Ended Output to Differential Input

Pulse Mode Wiring, Single Ended Inputs

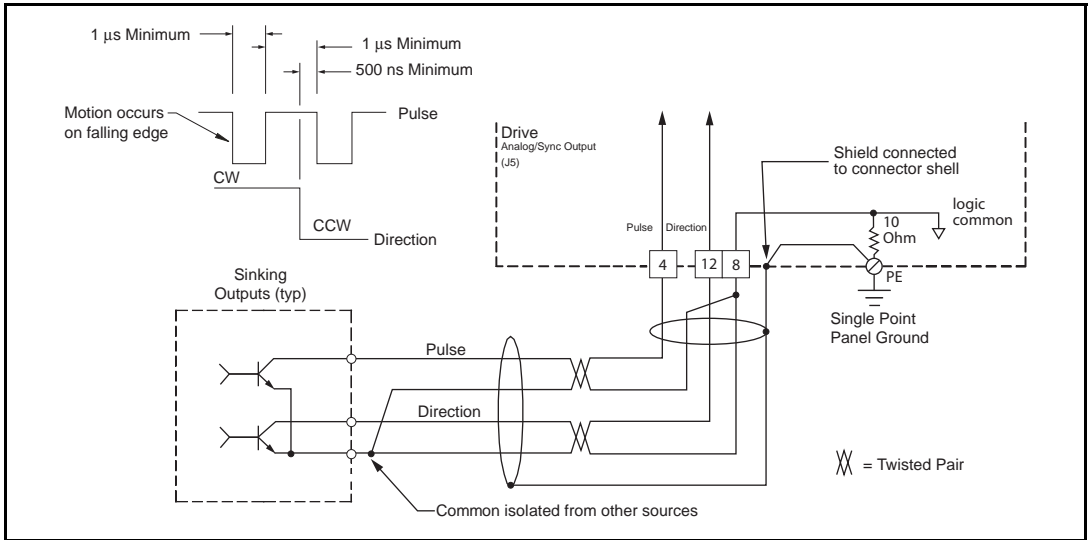

Figure 39: Pulse Mode, Single Ended Output to Single Ended Input (twisted pair cable)

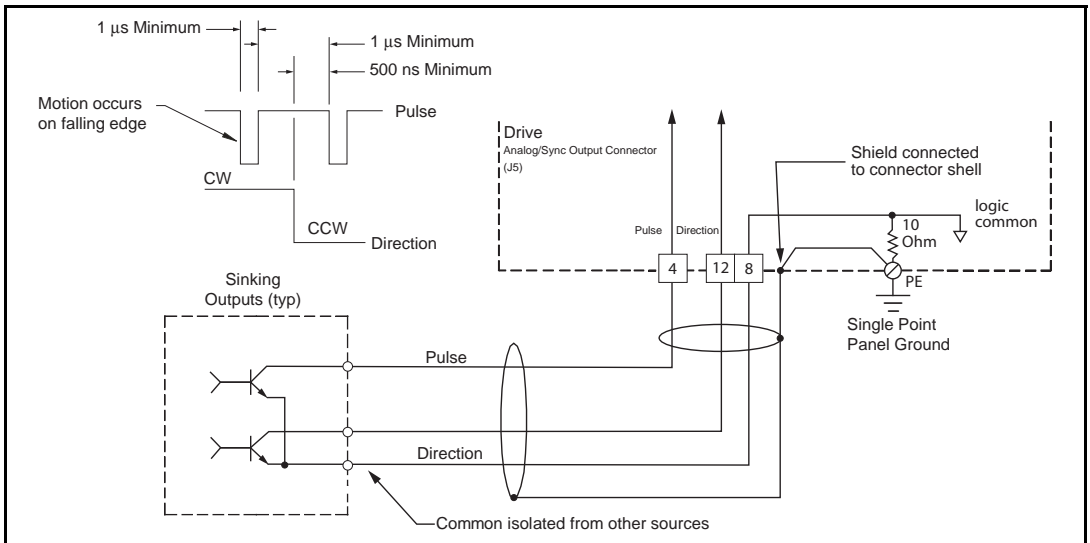

Figure 40: Pulse Mode, Single Ended Output to Single Ended Input (non-twisted pair cable)

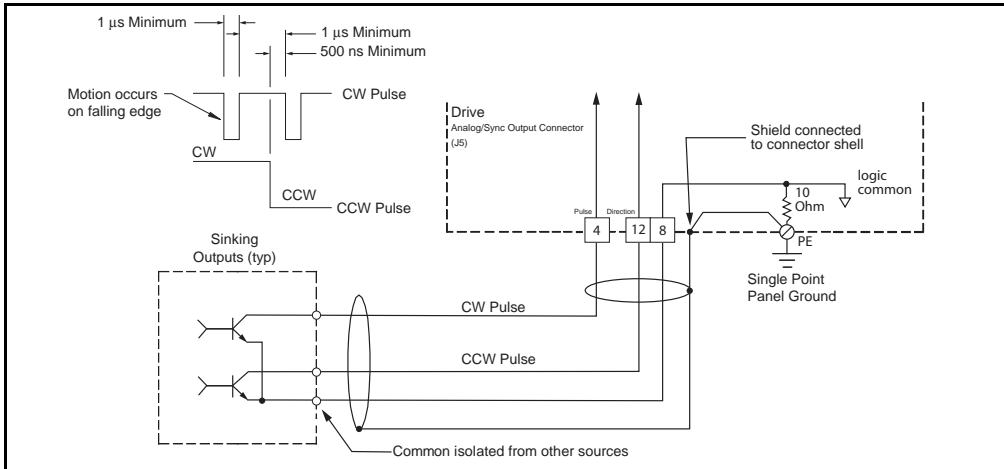

Figure 41: Pulse/Pulse Mode, Single Ended Output to Single Ended Input (non-twisted pair cable)

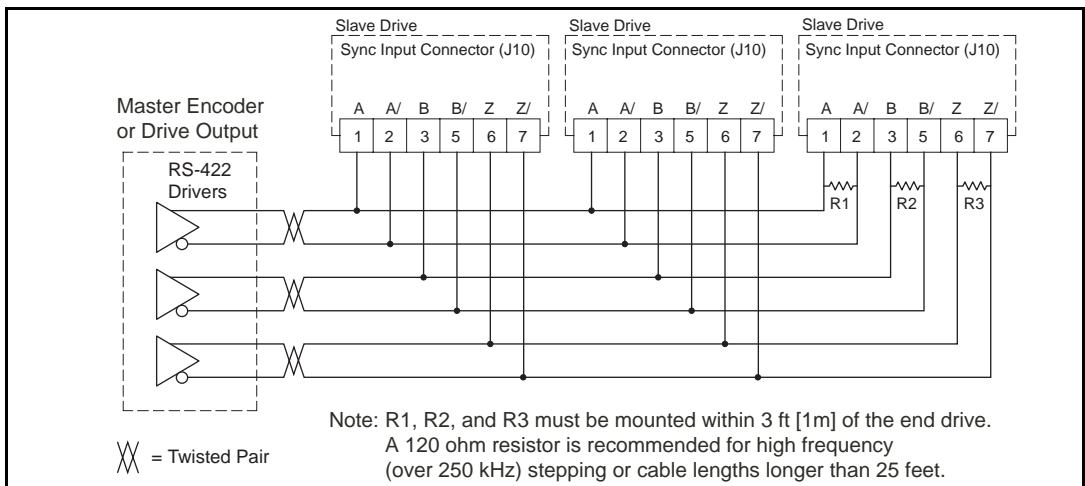

Figure 42: Master/Slave Encoder Connections

NOTE

Encoder outputs meet RS-422 driver specifications and can drive up to 10 RS-422 signal receivers. Each differential pulse input is an RS-422 line receivers. The default encoder output resolution is 2048 lines per motor revolution. This resolution is adjustable in one line per revolution increments with PowerTools Pro software. The range is between 1 and the actual motor encoder density.

Communications

Communications with the drive is provided through the RJ45 connectors located on the front of the drive. The two RJ45 connectors are identical and are used to provide a way to daisy chain two or more drives together using the DDC-RJ45 cable, see Figure 44. The Epsilon EP serial communication connector (serial port) as standard, supports 2 wire EIA485 communications. The RS-485 communications port is not isolated from drive electronics and the "0 V" pins are internally connected through a 10 Ohm resistor to PE. Interconnected drives should be within a zone of equipotential bonding. Connection to a master device on the network, such as a MMI, SCADA, PLC, or PR can be remote, but care should be taken to make sure the entire network operates within the +/-7 V common mode voltage range of RS-485. Though the comm port is part of PELV circuits when properly installed, if the master device is outside the zone of equipotential bonding the circuit needs to be isolated against direct contact. The minimal RS-485 network cable contains a shielded twisted pair for RX TX (pin 2) and /RX /TX (pin 7) with shield to the shell, though a 0 V reference signal (pin 3) can improve immunity to ground differentials. See the following table for the connection details for the RJ45 serial communication connector.

Pin	Function
1	120 ohm Termination resistor
2	RX TX
3	Isolated 0V
4	+15V (100 mA max)
5	Isolated 0V
6	TX Enable
7	RX/ TX/
8	RX/ TX/ (If termination resistors are required, link to pin 1)
SHELL	PE

The provision for connection of the internal 120 ohm terminating resistor at pin 1 and pin 8 would rarely, if ever, be needed unless data rates much higher than 19.2K are supported. Since a terminator connection is only made at the end of a trunk, it is most conveniently accomplished by crimping a short link from pin 1 to pin 8 in a new RJ45 connector and plugging it into the second RJ45 port on the "last" drive. Cable conductors should not be connected to these pins.

Communication Cables

The CT-Comms cable is an isolated RS-232 to RS-485 convertor that may be used to connect one or more EP drives to a master device using a standard 9 pin D-sub RS-232 serial comms port. The +15 V supply at pin 4 and the 0 V connection at pin 5 are intended only to provide power to the isolators in the CT-Comms cable and are not to be used for any other purpose.

The TX Enable signal at pin 6 and 0 V at pin 3 provide a transmit enable signal from each interconnected drive to a CT-Comms cable and are not to be used for any other purpose. They may be wired from drive to drive in a zone of equipotential bonding to allow the CT-Comms cable to communicate with all drives in the group.

The DDC-RJ45 provides drive to drive (daisy chain) connections between EP drives, including support for the CT-Comms cable in a group of drives.

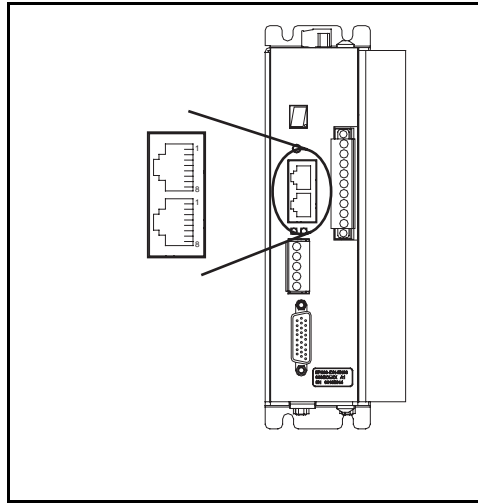

Figure 43: Epsilon EP Serial Communication Connector

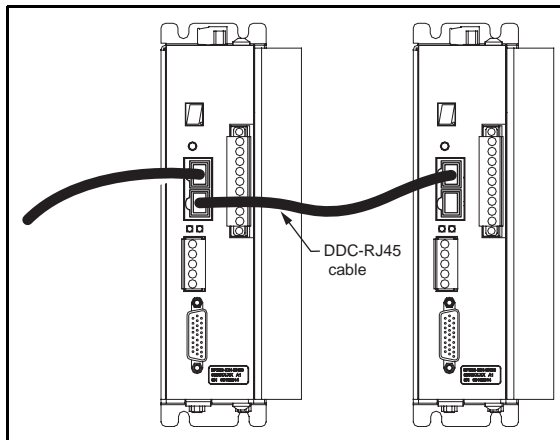

Figure 44: 2 Epsilon Drives Daisy Chained Together

CAUTION

When connecting the serial port of your PC to the serial port of the drive, verify that your PC's ground is the same as the drive PE ground. Failure to do so can result in damage to your PC and/or your drive. It is best to use an isolating cable such as the CT-Comms cable.

Modbus Communications

The drive's serial communication protocol is Modbus RTU slave with a 32 bit data extension. The Modbus protocol is available on most operator interface panels and PLC's.

Serial Communications Specifications	
Max baud rate	19.2k
Start bit	1
Stop bit	2
Parity	none
Data	8

Ethernet Port

The Ethernet port at J11 has only functional isolation from other low voltage circuits and PE at the drive. In order to classify any low voltage circuits in the drive as PELV, the ethernet circuit must be installed as a PELV circuit. Refer to installation instructions with the hub, switch or other devices connected for details.

The system meets EMC emissions and immunity requirements using unshielded ethernet cables when a clamp on ferrite is attached to the ethernet cable as it leaves the enclosure.

DeviceNet Port

The DeviceNet port at J9 has only functional isolation from other low voltage circuits and PE at the drive.









In order to classify any low voltage circuits in the drive as PELV, the DeviceNet circuit must also be installed as a PELV circuit.

Diagnostics and Troubleshooting

Diagnostic Display

Status Codes

The diagnostic display on the front of the drive shows drive status and fault codes. When a fault condition occurs, the drive will display the fault code, overriding the status code. The decimal point is "On" when the drive is enabled and the Stop input is not active. This indicates that the drive is ready to run and will respond to motion commands. Commands will not cause motion unless the decimal point is "On".

Display Indication	Status	Description
	Brake Engaged (Output "Off")	Motor brake is mechanically engaged. This character will only appear if the Brake output function is assigned to an output line. See Brake Operation section for detailed description of Brake Output function.
	Disabled	Power Stage is disabled.
	Ready	The system is functioning normally and is ready to execute a motion command
	Program	Program is executing. Other motion commands do not function.
	Position or Pulse	Pulse mode operation.
	Velocity	Velocity mode operation.
	Decelerating from Stop or Travel Limit Decel	Deceleration ramp after the Stop or Travel Limit function is activated. The ramp is displayed while decelerating, and the display will go back to normal after completing the decel ramp.
	Torque	Analog Torque mode operation.











Display Indication	Status	Description
+	Summation	Summation mode operation.
⌈	RMS Foldback	Motor torque is limited to 80 percent.
⌊	Stall Foldback	Drive output current is limited to 80 percent of the drive's stall current.
.	Ready to Run	Drive enabled, no Stop input.
h	Homing	Home cycle is executing. Other motion commands do not function.
X	Indexing	A Index is executing. Other motion commands do not function.
J	Jogging	Jog function is executing. Other motion commands do not function.
S	Stop or Travel Limit Decel	Stop or Travel Limit Decel is executing. No other motion will function.
G	Gearing	Gear function is executing.



Fault Codes

A number of diagnostic and fault detection circuits are incorporated to protect the drive. Some faults, like high DC bus and drive or motor over temperature, can be reset with the Reset button on the front of the drive or the Reset input function. Other faults, such as encoder faults, can only be reset by cycling power "Off" (wait until the diagnostics display turns "Off"), then power "On".

The drive accurately tracks motor position during fault conditions. For example, if there is a "Low DC Bus" fault where the power stage is disabled, the drive will continue to track the motor's position provided the logic power is not interrupted.

The +/- Travel Limit faults are automatically cleared when the fault condition is removed. The table below lists all the fault codes in priority order from highest to lowest. This means that if two faults are active, only the higher priority fault will be displayed.

Display	Fault	Action to Reset	Bridge Disabled
	Flash Invalid	Reprogram the Flash	Yes
	Drive Power Up Test	Cycle Logic Power	Yes
	NVM Invalid	Reset Button or Input Line	Yes
	Invalid Configuration	Reset Button or Input Line	Yes
	Drive Overtemp	Allow Drive to cool down, Cycle Logic Power	Yes
	Power Module	Reset Button or Input Line	Yes
	High DC Bus	Reset Button or Input Line	Yes
	Low DC Bus	Reset Button or Input Line	Yes
	Encoder State	Reset Button or Input Line on EP-P drive and Cycle Logic Power on the other models	Yes
	Encoder Hardware	Reset Button or Input Line on EP-P drive and Cycle Logic Power on the other models	Yes

Display	Fault	Action to Reset	Bridge Disabled
M	Motor Overtemp	Allow Motor to cool down, Reset Button or Input Line	Yes
	RMS Shunt Power	Reset Button or Input Line	Yes
	Overspeed	Reset Button or Input Line	Yes
F	Following Error (Pulse mode only)	Reset Button or Input Line	Yes
L	Travel Limit +/-	Auto	No
-	Sync Fault	Cycle Logic Power	Yes
4	Run Time (EP-P Only)	Reset Button or Input Line	Yes
	All "On"	Normally "On" for one second during power-up	Yes

Fault Descriptions



Flash Invalid

This fault indicates that the firmware checksum has failed. From the Tools>Program Flash menu in PowerTools Pro the firmware stored in flash memory can be reprogram or upgrade. If this problem persists, call Control Techniques. A common cause would be an interrupted F/W Flash upgrade (cable disconnected during an upgrade process).



Power Up Test

This fault indicates that the power-up self-test has failed. This fault cannot be reset with the reset command or reset button.



NVM Invalid

At power-up the drive tests the integrity of the non-volatile memory. This fault is generated if the contents of the non-volatile memory are invalid.



Invalid Configuration

This fault will occur if the digital board in the drive does not match the power board settings. It is only useful during manufacturing. A drive with this fault should be returned for service.



Drive Overtemp

Indicates the drive IGBT temperature has reached an over temperature condition. This fault is not currently implemented in the EP drive.



Power Module

This fault is generated when a power stage over-temperature, over-current or loss of power stage logic supply occurs. This can be the result of a motor short to ground, a short in the motor windings, a motor cable short or the failure of a switching transistor.



High DC Bus

This fault will occur whenever the voltage on the DC bus exceeds the High DC Bus threshold. The most likely cause of this fault would be an open external shunt, a high AC line condition, or an application that requires an external shunt (e.g., a large load with rapid deceleration) but none is installed.

	High DC Bus Threshold
Epsilon EP	415 Vdc



Low DC Bus

This fault will occur whenever the voltage on the DC bus drops below the Low DC Bus threshold. The most likely cause of this fault is a reduction (or loss) of AC power. A 50 ms debounce time is used with this fault to avoid faults caused by intermittent power disruption. With an Epsilon EP drive, the low DC bus monitoring can be disabled. In an EP-B and EP-I this fault is disabled by clearing the check box on the Faults view, and for an EP-P the check box is located on the Advanced view

	Low DC Bus Threshold
Epsilon EP	60 Vdc



Encoder State

Certain encoder state transitions are invalid and will cause the drive to report an encoder state fault. This is usually the result of noisy encoder feedback caused by poor shielding. For some types of custom motors it may be necessary to disable this fault. With an Epsilon EP drive, the Encoder State monitoring can be disabled. In an EP-B and EP-I this fault is disabled by clearing the check box on the Faults view, and for an EP-P the check box is located on the Advanced view.



Encoder Hardware

If any pair of complementary encoder lines (A, B, Z) are in the same state, an encoder line fault is generated. Also, can be generated if all three commutation channels (U, V, W) are 0 or 1, an illegal state. The most likely cause is a missing or bad encoder connection.



Motor Overtemp

This fault is generated when the motor thermal switch is open due to motor over-temperature or incorrect wiring.



Overspeed

This fault occurs in one of two circumstances:

1. When the actual motor speed exceeds the Overspeed Velocity Limit parameter or 150% of motor maximum operating speed. This parameter can be accessed with PowerTools Pro software.
2. If the combination of command pulse frequency and Pulse Ratio can generate a motor command speed in excess of the fixed limit of 13000 RPM, an Overspeed Fault will be activated. In Pulse mode operation and any Summation mode which uses Pulse mode, the input pulse command frequency is monitored and this calculation is made. For example, with a Pulse Ratio of 10 pulses per motor revolution, the first pulse received will cause an Overspeed fault even before there is any motor motion.



RMS Shunt

This fault is generated when filtered average shunt power dissipation is greater than the design rating of the shunt resistor.



Following Error

This fault is generated when the following error exceeds the following error limit (default following error limit for an EP-I and EP-B is 0.2 revs). With PowerTools Pro you can change the Following Error Limit value or disable it in the Position view. In an EP-B and EP-I the Following Error Limit is functional in Pulse mode only.



Travel Limit +/-

This fault is caused when either the + or - Travel Limit input function is active.



Sync Fault

This fault occurs when the user selected trajectory update rate is set too short based on the processor requirements. The three possible trajectory update rates are 800 μ s, 1200 μ s, or 1600 μ s. Try changing the trajectory update rate to the largest value (1600 μ s) and run the application again. If the problem persists after setting to 1600 μ s, contact Control Techniques technical support. For more information on the trajectory update rate see the *Epsilon EP-P Drive and FM-3/4 Modules Reference Manual* (P/N 400518-04).



Run Time Faults (EP-P only)

The "4" fault is caused by any of the following internal routine faults:

Trajectory Fault #1

This fault occurs when the drive commands motion that cannot be achieved due to excessive following error, accel, decel, velocity settings, or unuseable user units. Check the user units, velocities, accels and decels for correct values.

Trajectory Fault #2

This fault occurs when using the "Using Capture.#" option in a user program. If the capture has never been triggered, or the capture data has gone "stale", the drive will not be able to process motion properly.

Program Fault

This fault indicates a problem was encountered in a user program. For example: an illegal math operation resulting in a divide by zero or overflow of 32-bit data. This error can also occur if trying to access a drive parameter that is non-existent or not available to the user.

Invalid Configuration Fault #2

The user program in flash memory will not run. Download the user program again using PowerTools Pro. A common cause of this fault could be an interrupted configuration download, such as a cable being disconnected during the download.

No Program

This fault will be displayed on initial power-up indicating that no configuration has been downloaded to the drive. To clear the fault, download a valid configuration to the drive.



All "On"

This is a normal condition during power up of the drive. It will last for less than 1 second. If this display persists, call Control Techniques Americas LLC for service advice.

Normally, "All On" for less than one second during power-up. All segments dimly lit when power is "Off" may occur when an external signal is applied to the encoder inputs (motor or master) or serial port from an externally powered device.

Diagnostic Analog Output Test Points

The drive has two 10-bit real-time Analog Outputs which may be used for diagnostics, monitoring or control purposes. These outputs are referred to as Channel 1 and Channel 2. They can be accessed from the Analog/Sync Output Connector (J5) on the drive.

Each Channel provides a programmable Analog Output Source.

Analog Output Source options are:

- Velocity Command
- Velocity Feedback
- Torque Command (equates to Torque Command Actual parameter)
- Torque Feedback
- Following Error
- Position Feedback (EP-B, EP-I, and EP-IDN)
- Custom Variable (EP-P only)
- Analog In (EP-P only)

Channel	Analog/Sync Output Connector (J5) Pin#
1	7
2	15

Drive Faults

The Active Drive Faults dialog box is automatically displayed whenever a fault occurs. There are two options in this dialog box: Reset Faults and Ignore Faults.

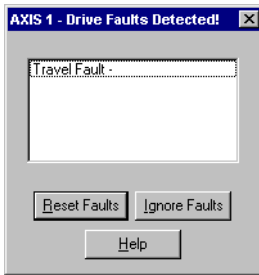

Figure 45: Active Drive Faults Detected Dialog Box

Resetting Faults

Some drive faults are automatically reset when the fault condition is cleared. Other faults require drive logic power to be cycled or the drive to be “rebooted”. If you wish to continue working in the PowerTools Pro software without resetting the fault, click the *Ignore Fault* button.

To reset faults that can be reset with the *Reset Faults* button, simply click the *Reset Faults* button in the Drive Faults Detected dialog box or push the Reset button on the front of the drive where the fault occurred.

Viewing Active Drive Faults

To view all active drive faults, select the View Faults command from the **Device** menu or by clicking on the View Faults button on the toolbar. The dialog box displayed is the same as Active Drive Faults Detected dialog box described above.

Rebooting the Drive

To reboot the drive, cycle power or select the Reboot Drive command from the **Device** menu. This command reboots the drive attached to the active Configuration Window.

Options and Accessories

Epsilon EP Drive Options

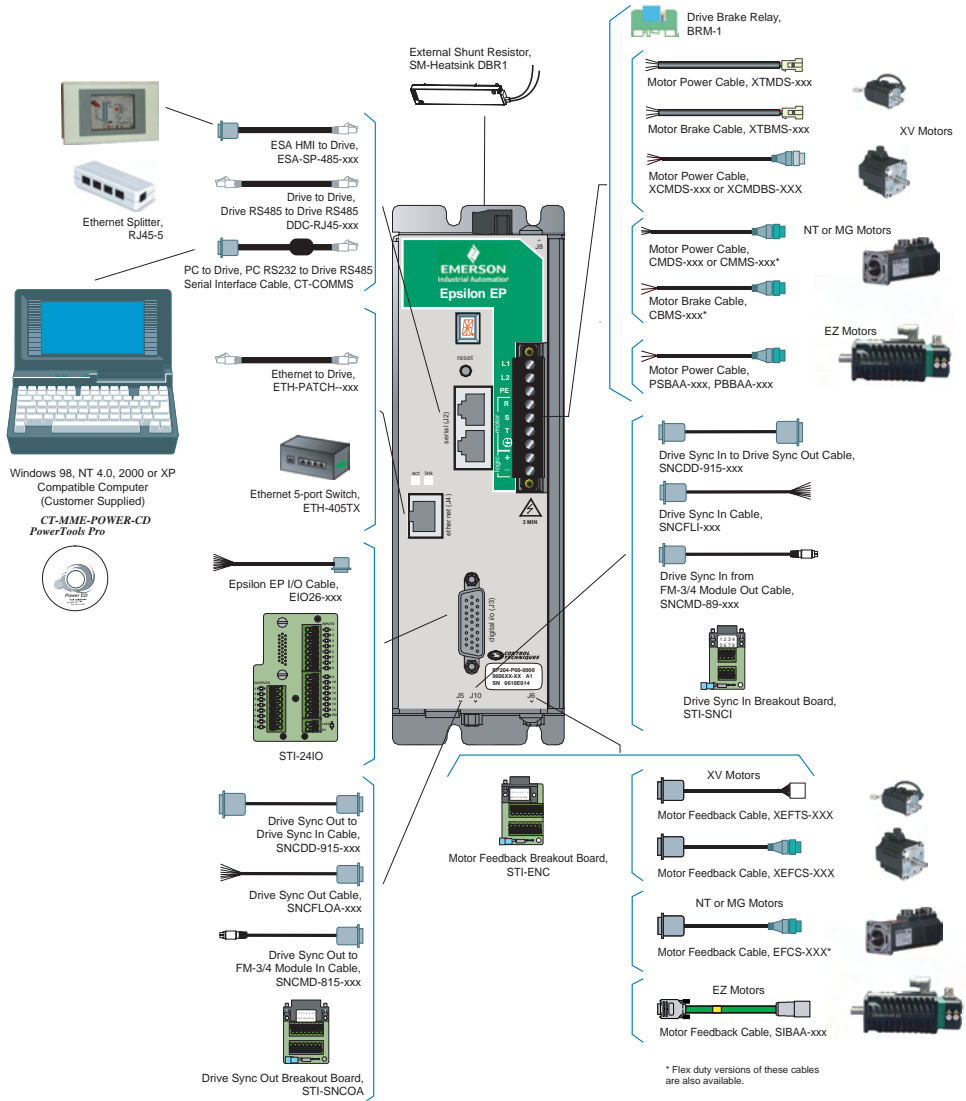

Figure 46: Epsilon EP-P Drive shown with Options

STI-24IO

The STI-24IO interface board allows access to all digital input and output signals. The STI-24IO mounts directly to the digital I/O connector (J3) on the front of the EP drive. See figure 47 below.

CAUTION

Do not allow ESD directly to terminals. Always discharge static electricity to enclosure, not the drive when performing maintenance.

NOTE

Shield connection points are connected to the shell of the 26 pin "D" connector on the STI-24IO.

The STI-24IO wire range is #18 to 24 AWG stranded insulated wire.

NOTE

Wiring should be done with consideration for future troubleshooting and repair. All wiring should be either color coded and/or tagged with industrial wire tabs. Low voltage wiring should be routed away from high voltage wiring.

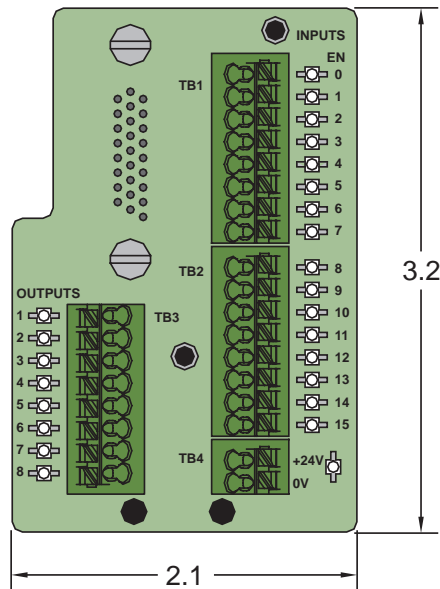

Figure 47: Dimensions of the STI-24IO Board

STI-SNCOA

The STI-SNCOA interface board allows access to the analog/sync signals. The STI-SNCOA plugs directly into the J5 connector on the bottom of the drive. The numbers printed on the connector label correlate to the screw terminal numbers.

CAUTION

Do not allow ESD directly to terminals. Always discharge static electricity to enclosure, not the drive when performing maintenance.

NOTE

Shield connection points are connected from the shell of the "D" connector to the faston lug connector.

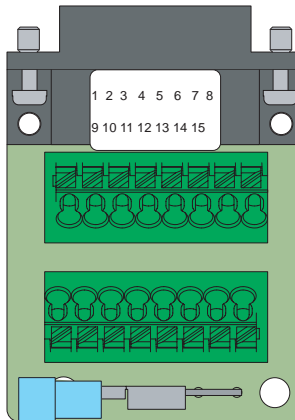

Figure 48: STI-SNCOA Drive Analog/Sync Output Breakout Board

STI-SNCI

The STI-SNCI interface board allows access to the sync input connections on the EP drive. The STI-SNCI plugs directly into the J10 connector on the bottom of the drive. The numbers printed on the connector label correlate to the screw terminal numbers.

CAUTION

Do not allow ESD directly to terminals. Always discharge static electricity to enclosure, not the drive when performing maintenance.

NOTE

Shield connection points are connected from the shell of the "D" connector to the faston lug connector.

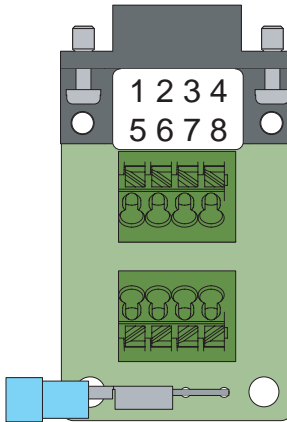

Figure 49: STI-SNCI Drive Sync In Breakout Board

STI-ENC

The STI-ENC interface board allows the user access to the encoder feedback connector (J6) on the EP drive. The STI-ENC plugs directly in J6 on the bottom of the drive. The numbers printed on the connector label correlate to the screw terminal numbers.

CAUTION

Do not allow ESD directly to terminals. Always discharge static electricity to enclosure, not the drive when performing maintenance.

NOTE

Shield connection points are connected from the shell of the "D" connector to the faston lug connector.

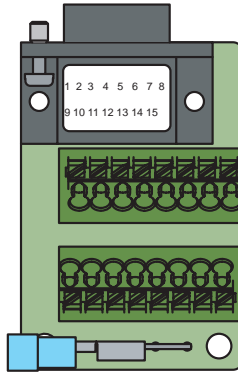

Figure 50: STI-ENC Drive Encoder Feedback Board

Specifications

Epsilon EP Specifications

Epsilon EP Series				
Power Requirements	20 Vac-264 Vac, 1 Ø, 47-63 Hz (240 Vac for rated performance) Type TN (Grounded) Installation Category III			
SCCR (Short Circuit Current Rating)	10,000 Symmetrical RMS Amps			
Rated Output Current and Power	Model	Continuous Power	Continuous Current	Peak Current
	EP202	670 W	2.2 A RMS at 40°C or 50°C	4.4 A RMS
	EP204	1140 W	4.0 A RMS at 40° C 3.6 A RMS at 50° C	8 A RMS
	EP206	1610 W	6.5 A RMS at 40° C 5.2 A RMS at 50° C	13 A RMS
Continuous Input Current (AC Input)	Model	Continuous Current	Inrush Current	
	EP202	5.0 A RMS at 40° C or 50° C	40 A RMS for 5 ms	
	EP204	8.5 A RMS at 40° C 7.6 A RMS at 50° C	65 A RMS for 5 ms	
	EP206	12.0 A RMS at 40° C 9.6 A RMS at 50° C	100 A RMS for 5 ms	
Logic Power Supply Input	24 Vdc ±10%	EP-P: 0.50 A without master encoder, 0.57 A with master encoder		
		Other models: 0.31 A without motor encoder, 0.38 with master motor encoder		
Switching Frequency	10 kHz			
Power Supply Output	5 Vdc, 250 mA maximum (for master encoder)			
Efficiency - Drive	EP202/204: 93% at full rated output power EP206: 95% at full rated output power			
Ingress Protection (IP) Rating	Drive: IP20 NT motors: IP65/IP54 Molded motor and feedback cables: IP65			
Serial Interface	RS-485 Modbus protocol with 32 bit data extension 19.2 k baud (default) or 9600 baud			
EtherNet Interface EP-P Only	10/100 M baud, auto negotiated Auto crossover Full/Half Duplex, auto negotiated EtherNet I/P, Modbus TCP/IP, HTTP, and SMSC			
DeviceNet Interface EP-xDN Only	Baud Rates: 125K, 250K, 500K Power from Network: 25 mA max.			

Epsilon EP Series	
Control Inputs	<p>Analog command: ± 10 Vdc 14 bit, 100 kOhm impedance, differential</p> <p>Absolute Maximum Input Voltage Input: +/- 14 Vdc to ground or differential, including drive enable</p> <p>Digital Inputs: 5 on the EP-B and 16 on the EP-I and EP-P including the drive enable input, 10 Vdc - 30 Vdc, 4.8 kohm impedance; current sourcing signal compatible (active high); max input response time is 500 μs; optically isolated.</p> <p>Input debounce: 0-2000 ms configured in PowerTools Pro</p>
Control Outputs	<p>Diagnostic Analog Outputs: (2) ± 10 Vdc into 10 Kohm (single ended), short circuit proof to ground, short circuit proof to ground, 10 bit, software selectable output signals</p> <p>Digital Outputs: 3 on EP-B, 8 on the EP-I and EP-P, 150 mA max each, short circuit proof, current source from 10 Vdc - 30 Vdc I/O power supply, 3.5 Vdc max supply to output voltage drop @ 150 mA, opto-isolated</p> <p>Motor temp sensor: Contact: 5 Vdc O.C. (tripped), 0.5 mA S.C. (normal) Compatible with PTC thermistor with 1 kOhm resistance at trip point</p>
Pulse Mode	<p>Interface: Software selectable differential (RS422) or single ended (TTL Schmitt Trigger)</p> <p>Maximum input frequency: Differential - 1 MHz per channel; (4 million counts/second in quadrature), 0.5 μs minimum pulse width Single ended - 500 kHz per channel; (2 million counts/second in quadrature), 1 μs minimum pulse width</p> <p>Ratio Capabilities: 20 to 163,840,000 PPR</p> <p>Single ended inputs have 1 kohm pull-up to 5 V</p>
Encoder Output Signal	<p>Differential line driver, RS-422 and TTL compatible</p> <p>Scalable in one line increment resolution up to 2048 lines/rev of the motor (NT)</p>
Shunt Resistor Capacity/Regeneration Capacity	<p>Energy storage available in bus caps: EP202: 15 J @ 240 Vac, 30 J @ 120 Vac EP204: 24 J @ 240 Vac, 63 J @ 120 Vac EP206: 40 J @ 240 Vac, 104 J @ 120 Vac</p> <p>EP204/EP206 External Shunt Control: 12 A peak, 2 kW max average power, 33 ohm minimum external resistor</p>
Earth Leakage Current and RCD Compatibility	<p>25 mA AC and < 0.1 mA DC with 15 ft (4.6 m) CMDS motor power cable and NT-330 motor at 240 Vac. Leakage is higher with longer cables. The EP drive is compatible with a Type A Residual current Detector (RCD) that allows expected leakage currents.</p>

Epsilon EP Series	
Fault Detection Capability	Low DC bus (can be disabled) High DC bus Power Stage fault Logic power Encoder state Encoder line break Drive overtemperature Motor overtemperature Overspeed Travel limit (+) Travel limit (-) Following error Power-up self test failure Non-volatile memory invalid
Cooling Method	EP202, EP204, EP206: Natural Convection
Environmental	Pollution degree 2 environment, Maximum surrounding air temperature: 40°C full rating, 50°C with derating Minimum operating temperature: 0°C Storage Temperature: -25°C to 75°C Rated Altitude: 3250 ft [1000 m] Higher Altitude: Derate output current; 1% / 100m above 1000m Humidity: 10% to 95% - non-condensing Vibration: 2g, 10 Hz to 2000 Hz
Standards and Agency Approvals	UL listed Canadian UL listed CE Mark: Low voltage directive; EMC directive
Drive Weights	EP202-B, -I, -IDN 3.6 lb (1.63 kg) EP204-B, I, -IDN 3.6 lb (1.63 kg) EP206-B, -I, -IDN 4.2 lb (1.91 kg) EP202-P 3.9 lb (1.77 kg) EP204-P 3.9 lb (1.77 kg) EP206-P 4.5lb (2.04 kg)

Epsilon EP Drive Dimensions

The following table applies to A* and B* as shown in the figure below.

Drive Model	Dimension A* (shown in inches/mm)	Dimension B* (shown in inches/mm)
EP202-B,-I,-IDN	2.11 [53.59]	0.45 [11.4]
EP204-B,-I,-IDN	2.11 [53.59]	0.45 [11.4]
EP206-B,-I,-IDN	2.82 [71.63]	0.45 [11.4]
EP202-P	2.69 [68.3]	1.03 [26.16]
EP204-P	2.69 [68.3]	1.03 [26.16]
EP206-P	3.40 [86.9]	1.03 [26.16]

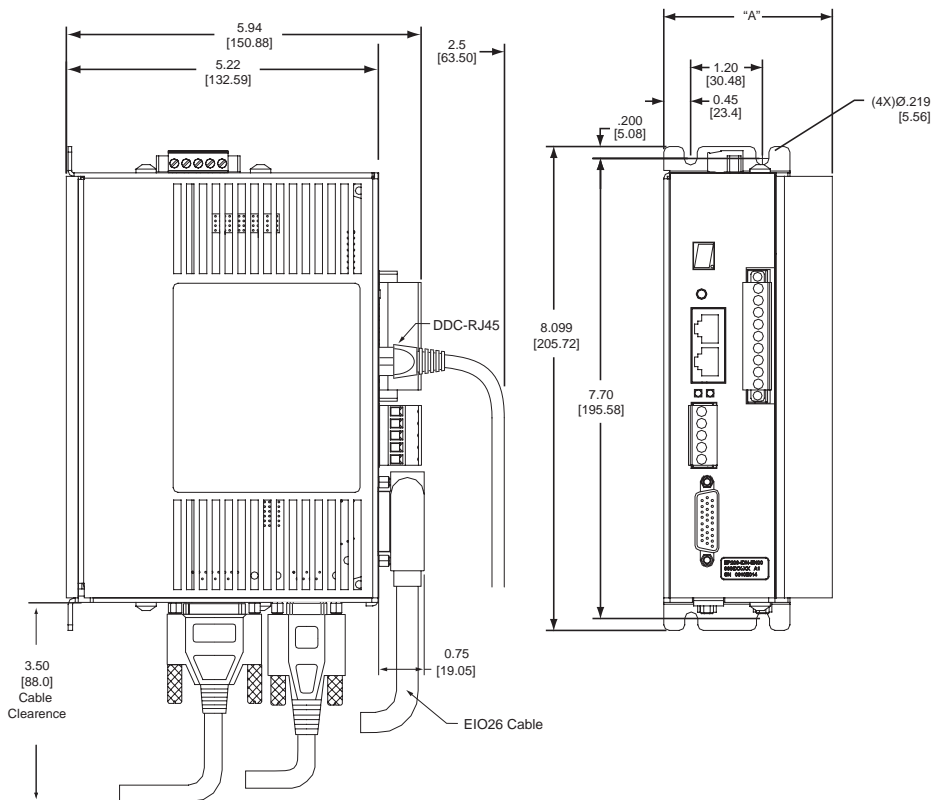

Cable Diagrams

EIO26 Cable

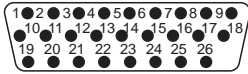
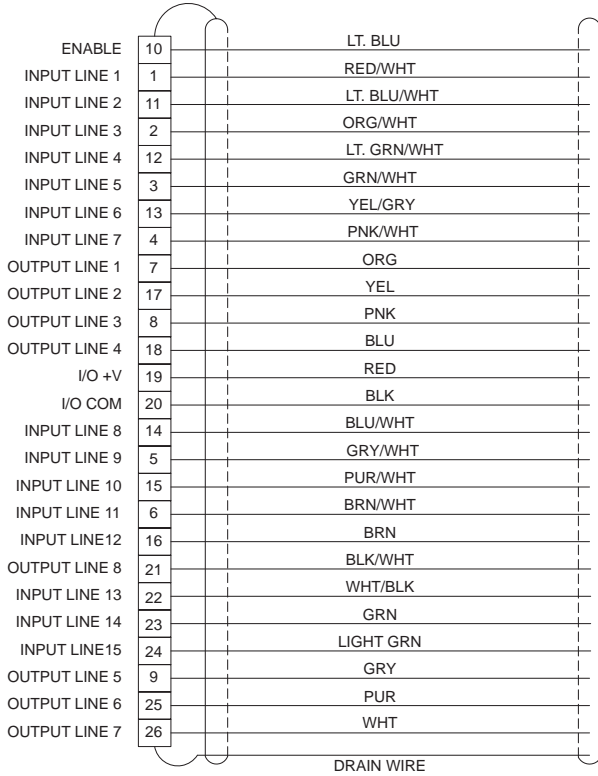
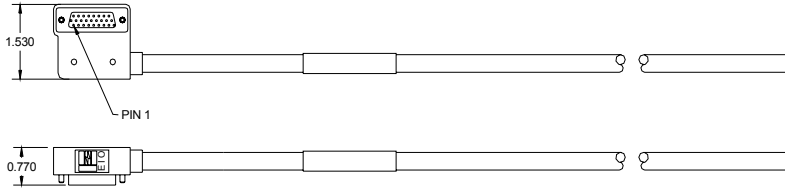

SOLDER SIDE
Socket

XV Motor Cables

XTMDS-XXX Cable

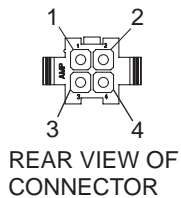
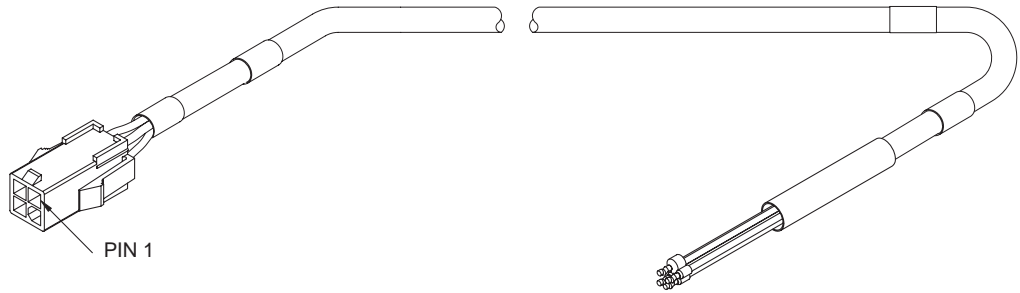

XCMDS-XXX

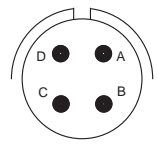
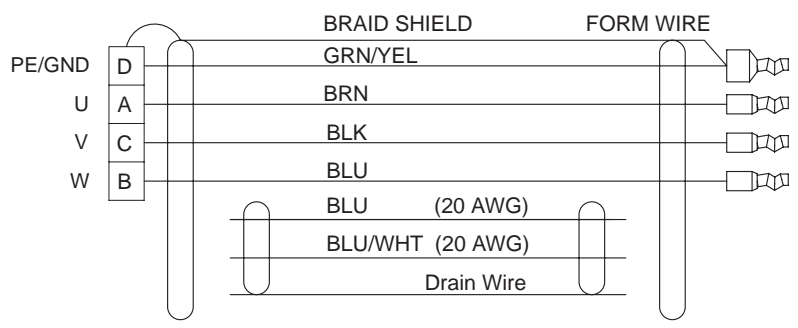
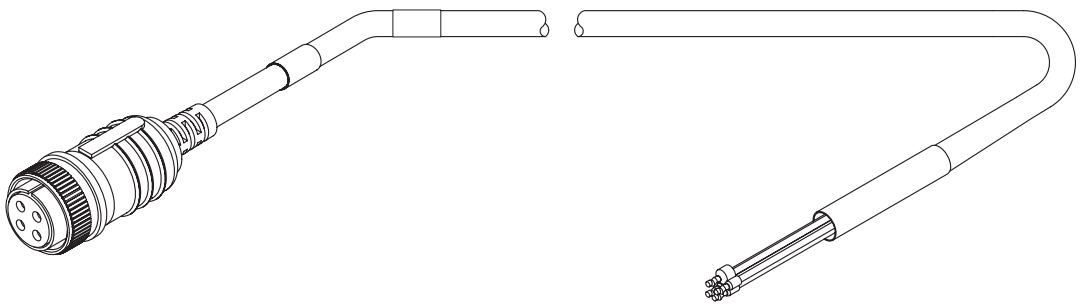

SOLDER SIDE
Socket

XCMDBS-XXX

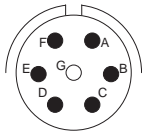
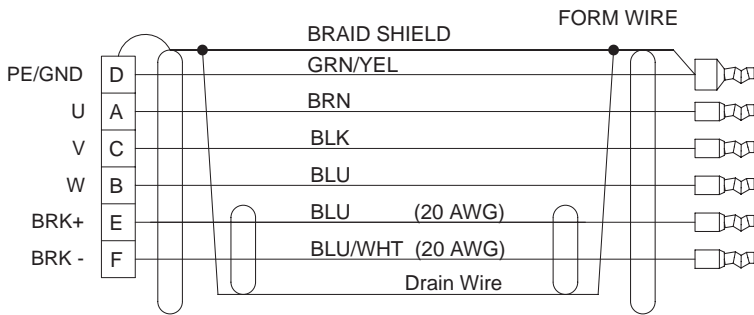
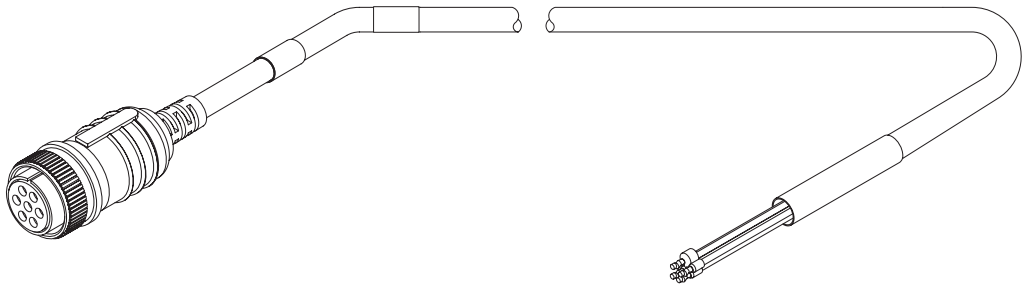

SOLDER SIDE
Socket

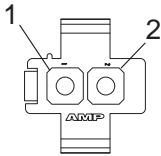
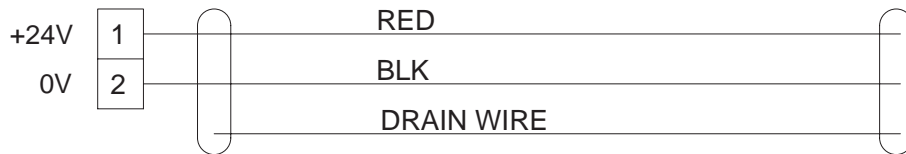
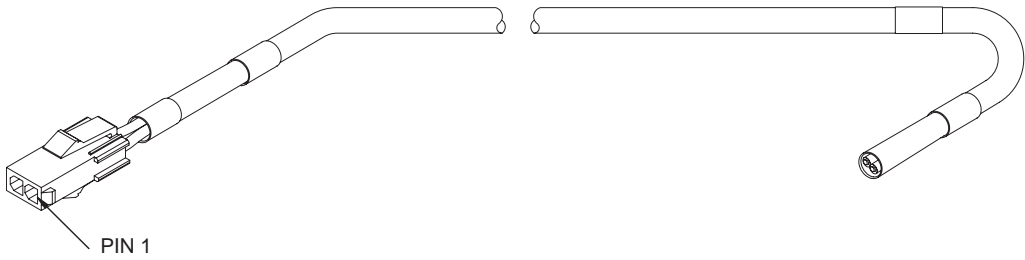
XTBMS-XXX

REAR VIEW OF
CONNECTOR

XEFTS-XXX Cable

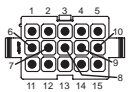
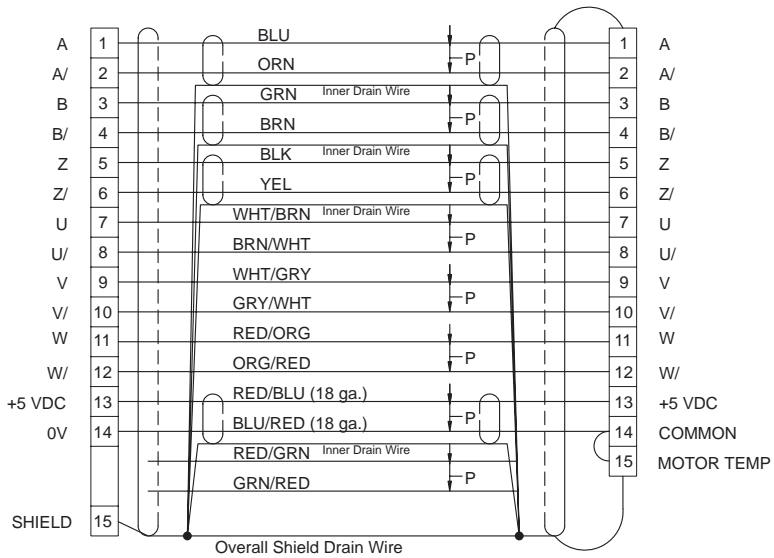
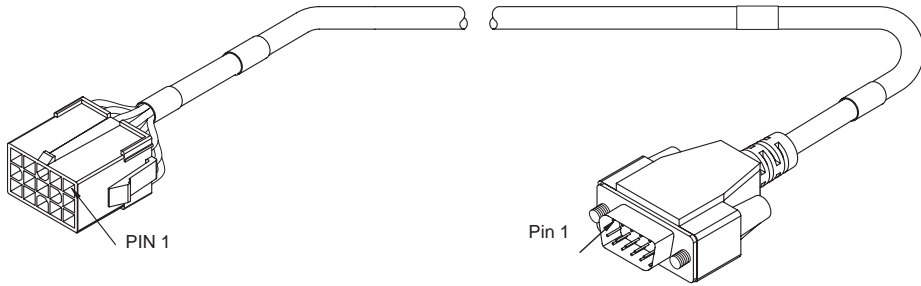

REAR VIEW OF CONNECTOR

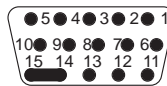

SOLDER SIDE
Pin

XEFCS-XXX Cable

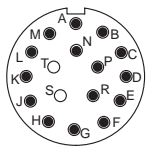
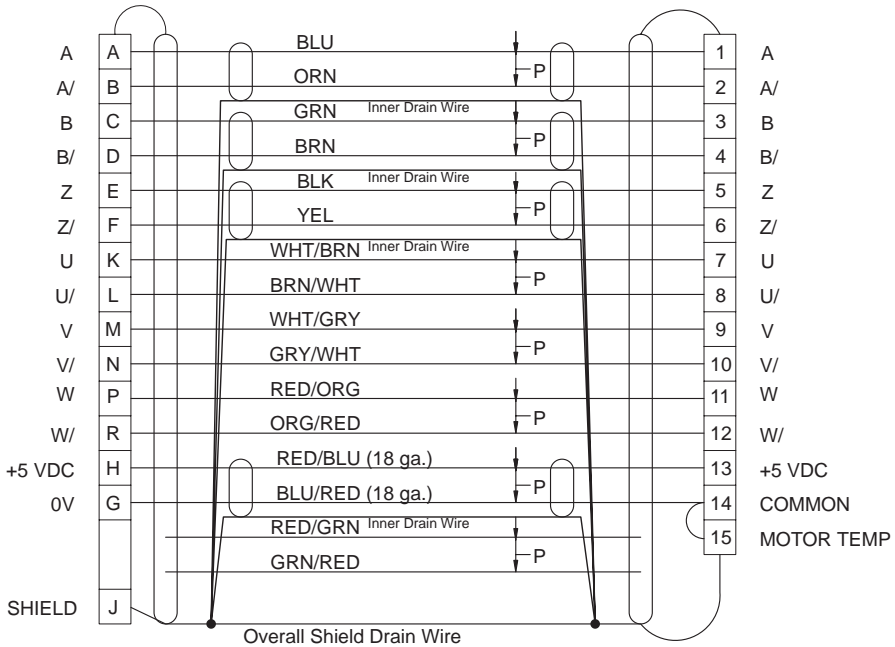
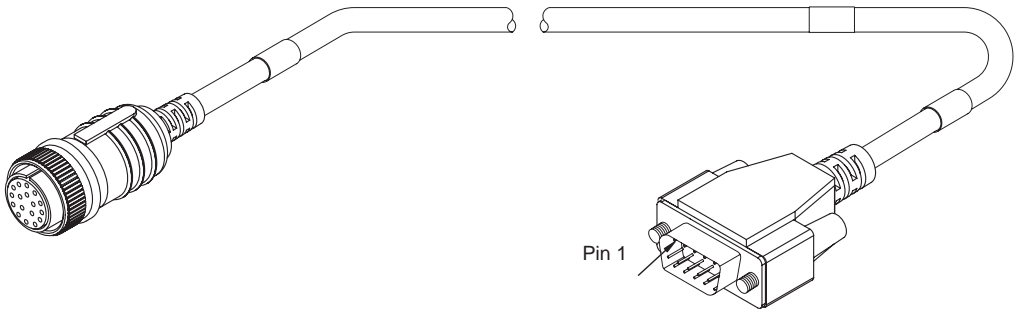

SOLDER SIDE
Socket

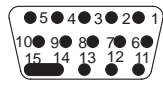

SOLDER SIDE
Pin

NT and MG Motor Cables

CMDS-XXX Cable

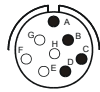
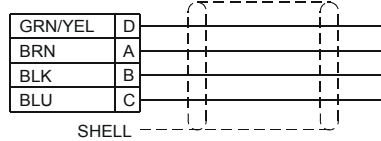
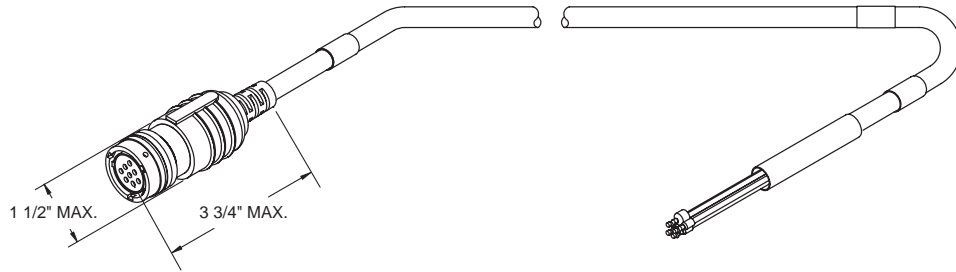

SOLDER SIDE

CMMS-XXX Cable

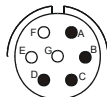
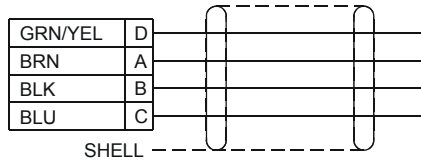
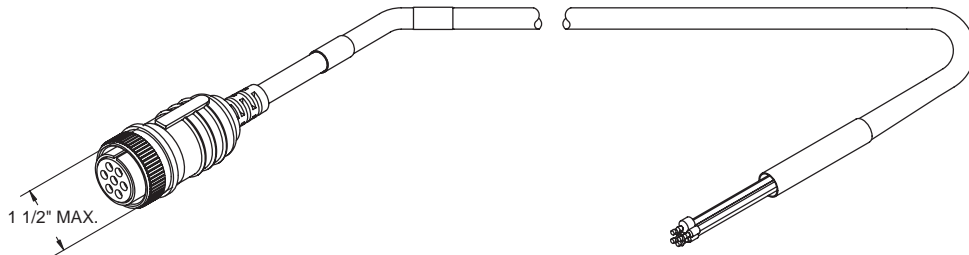

SOLDER SIDE

CBMS-XXX Cable

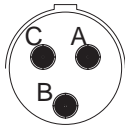
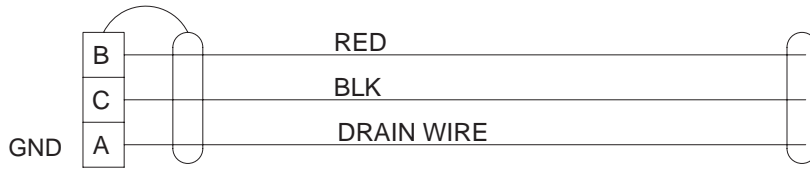
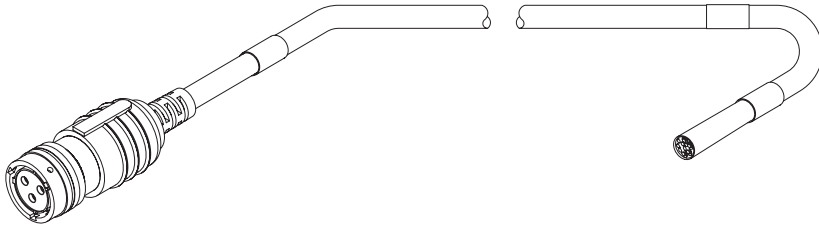

SOLDER SIDE
Socket

EFCS-XXX Cable

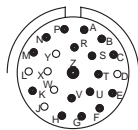
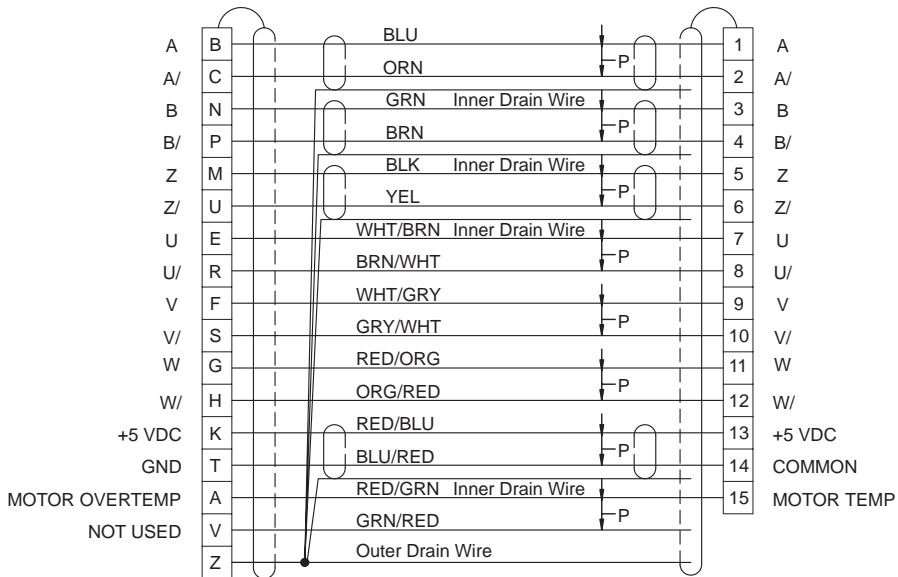
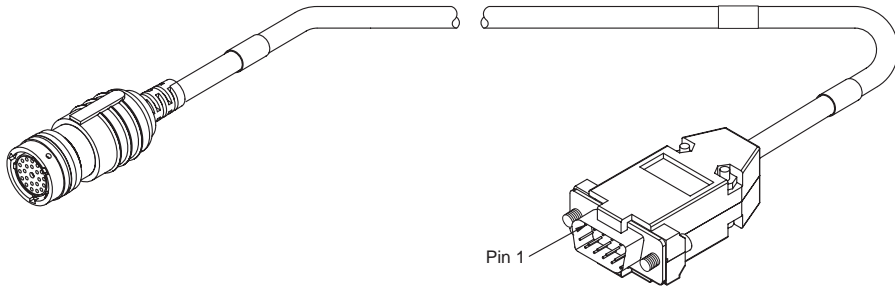

SOLDER SIDE
Socket
To Motor MG/NT/MH

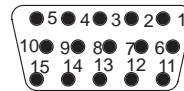

SOLDER SIDE
Pin
To Epsilon EP

Sync Cables

SNCDD-915-XXX

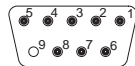
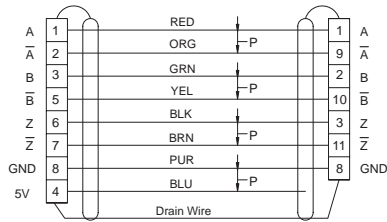
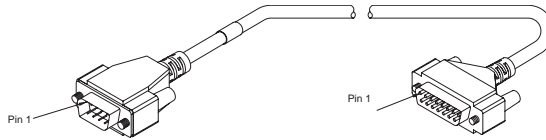

SOLDER SIDE
Pin

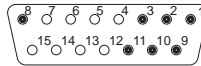

SOLDER SIDE
Pin

SNCFLOA-XXX

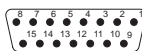
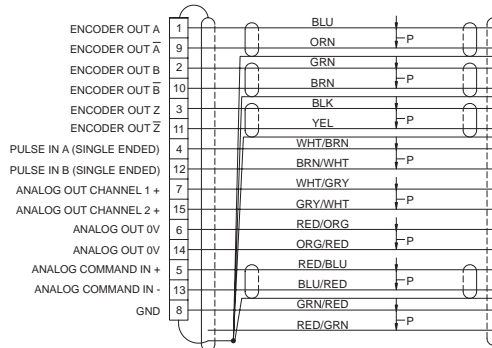
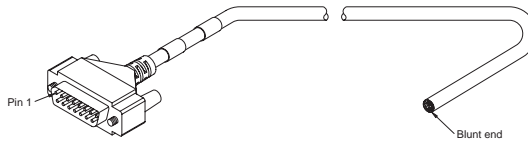

SOLDER SIDE
Pin

SNCMD-815-XXX

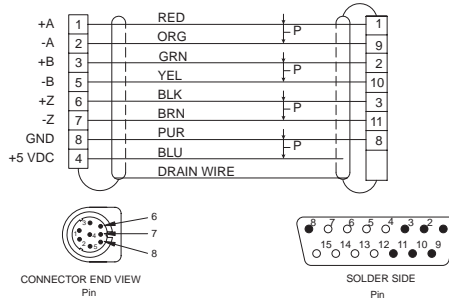
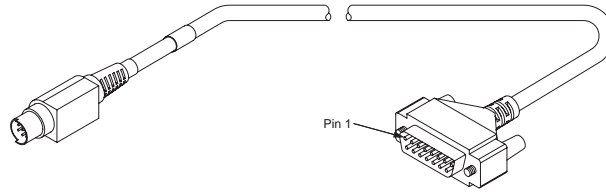

SNCFLI-XXX

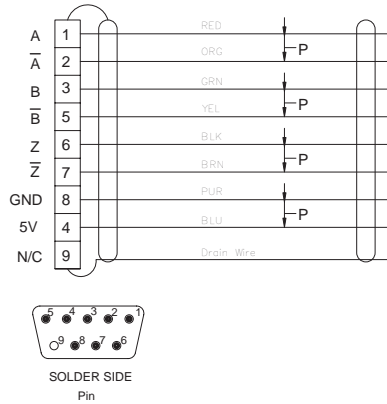
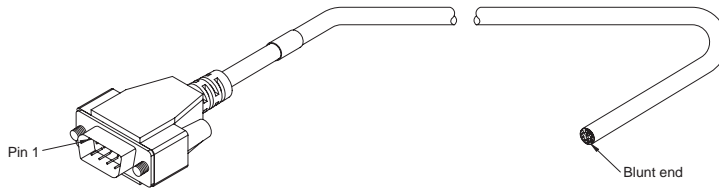

SNCMD-89-XXX

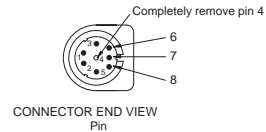
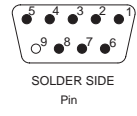
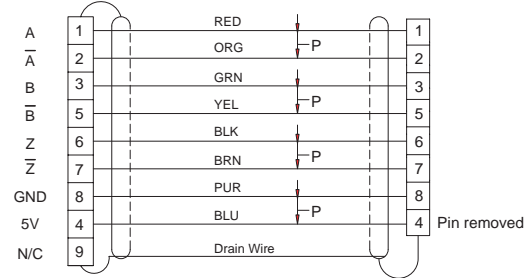
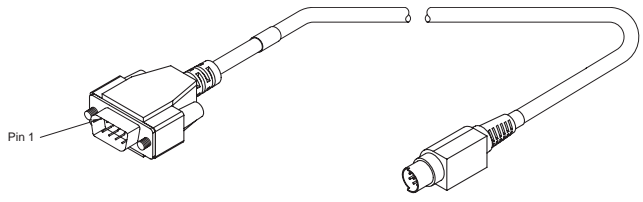

Communications Cables

ESA-SP-485-XXX

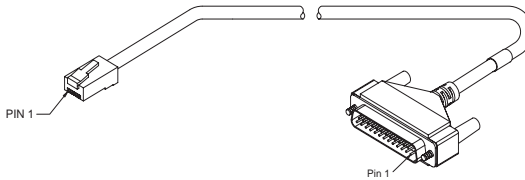
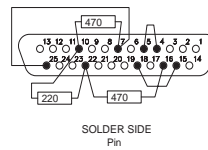
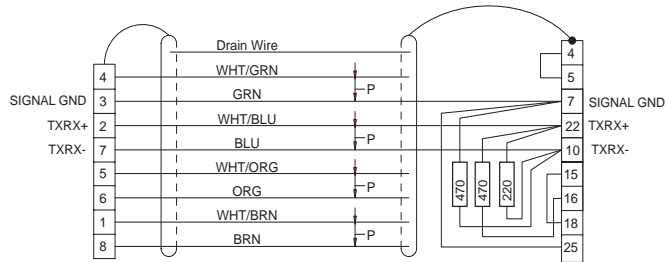

ETH-PATCH-XXX

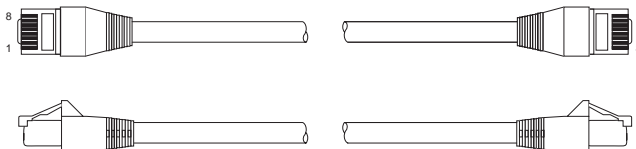

Index

A

AC Line Filter Installation Notes, 7
AC Line Filters, 6
AC Supplies NOT Requiring Transformers, 11
AC Supplies Requiring Transformers, 12
Achieving Low Impedance Connections, 3
Analog Command Wiring, 32

B

Basic Installation Guidelines, 3

C

Cable Diagrams, 59
Cable to Enclosure Shielding, 6
CMDS-XXX Cable, 66
CMMS-XXX Cable, 66

D

DC Logic Power Supply Wiring, 22
Declaration of Conformity, vii
Diagnostic Analog Output Test Points, 47
Diagnostic Display, 41
Diagnostics and Troubleshooting, 41
Drive Enable Wiring, 26
Drive Faults, 47
Drive overload protection, vi

E

EIO26-XXX Cable, 59
Electromagnetic Compatibility, 3
Encoder Output Signal Wiring, 32
Environmental Considerations, 4
Epsilon EP Drive Options, 49
Epsilon EP Specifications, 55

F

Fault Codes, 42
Fault Descriptions, 44
Feature Location, 1

H

High Power Connections, 10

I

Input Power Connections, 17
Input/Output, 26
Installation, 3

L

Line Fusing, 16
Logic Power Supply Specification, 22

M

Motor Brake Wiring, 25
Motor Feedback Wiring, 23
Motor Power Wiring, 19

O

Options and Accessories, 49

P

Product Overview, 1
Pulse Mode Wiring, 34

R

Rebooting the Drive, 48
Resetting Faults, 48

S

Safety Information, iii
Safety of Machinery, iii
Safety Precautions, iii
Setup, Commissioning and Maintenance, iii
Shunt Control, 18
Shunt Resistor Kit Installation, 18
Specifications, 55

T

Transformer Sizing, 14

U

Underwriters Laboratories Recognition, v

V

Viewing Active Drive Faults, 48

W

Wire Size, 16
Wiring Notes, 4

Since 1979, the “Motion Made Easy” products, designed and manufactured in Minnesota U.S.A., are renowned in the motion control industry for their ease of use, reliability and high performance.

For more information about Control Techniques “Motion Made Easy” products and services, call (800) 893-2321 or contact our website at www.emersonct.com.

Control Techniques Americas LLC
Division of EMERSON Co.
12005 Technology Drive
Eden Prairie, Minnesota 55344-3620
U.S.A.

Customer Service

Phone: (952) 995-8000 or (800) 893-2321
Fax: (952) 995-8129

Technical Support

Phone: (952) 995-8033 or (800) 893-2321
Fax (952) 995-8020

Printed in U.S.A.