

Transmission and Distribution Technology



Engineered to provide reliability and easy maintenance.

High-Pressure Gas Regulator Products From the Technology Leader

Precisely engineered to provide reliability and easy maintenance.

Our global customers and future customers require precise regulation of high-pressure transmission pipelines that move natural gas. To meet their needs, Emerson Process Management Regulator Technologies (Emerson Process Management) EZH and FL Series specifically handle high pressures found in gas transmission lines. These regulators have been engineered to exacting standards to control the flow of gas under very high pressure as it moves along the pipeline. Our high-pressure gas regulators are carefully designed, thoroughly tested and developed to handle higher system pressures, ensuring gas delivery and reduced noise output, resulting in increased capacity without emission of natural gas.

Product Advantages:

- Meet Higher System Requirements
 - Inlet pressures up to 103 bar / 1500 psig
 - High capacities
- Reduce Ownership Cost
 - Robust trim design
 - Longer service life
 - Top-entry maintenance
 - Installation/Maintenance
 - Eliminate bleed of gas
- Eliminate Emissions
 - No bleed technology
 - Environmentally friendly design
- Ensure Gas Delivery
 - Fail-open alternative maximizing uptime
- Reduce Noise Output
 - More efficient source treatment
 - Easy field retrofit

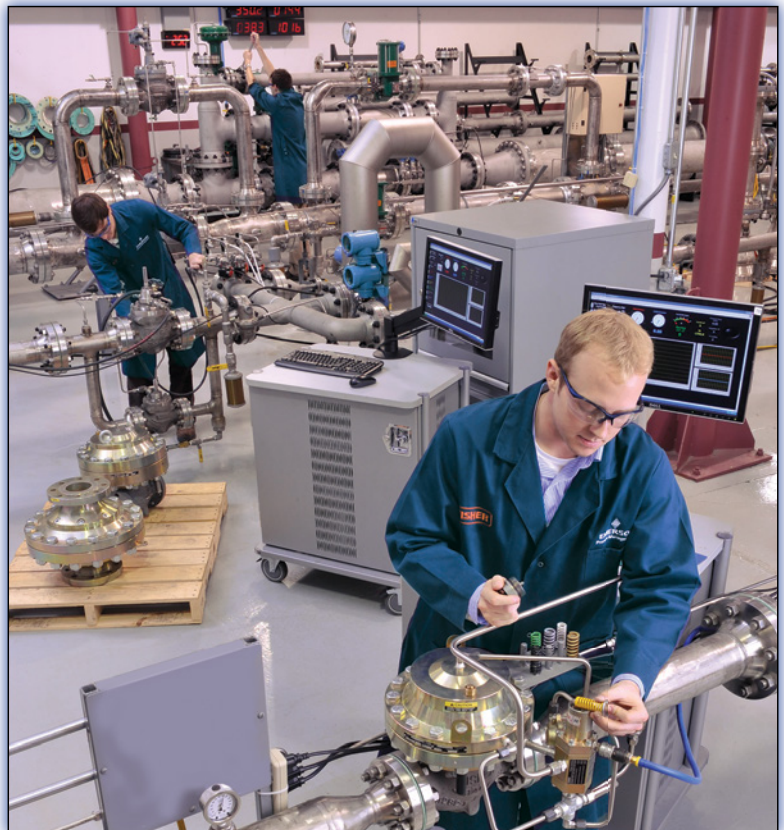

Testing the Type EZH with Noise Attenuation Technology in Emerson's flow laboratory in McKinney, Texas



Custom FL Series skid

Transmission skids custom-made for any application.

Emerson™ has many years of experience designing and assembling regulating and metering stations. An array of standard and customized installations is available for transmission applications. Our pressure-reducing stations can be developed for open air, underground or cabinet/building-protected applications.

New Product Options for Reliability, Ease of Use and Greater Noise Attenuation

Emerson™ offers new product options that are easier to use and reliable.

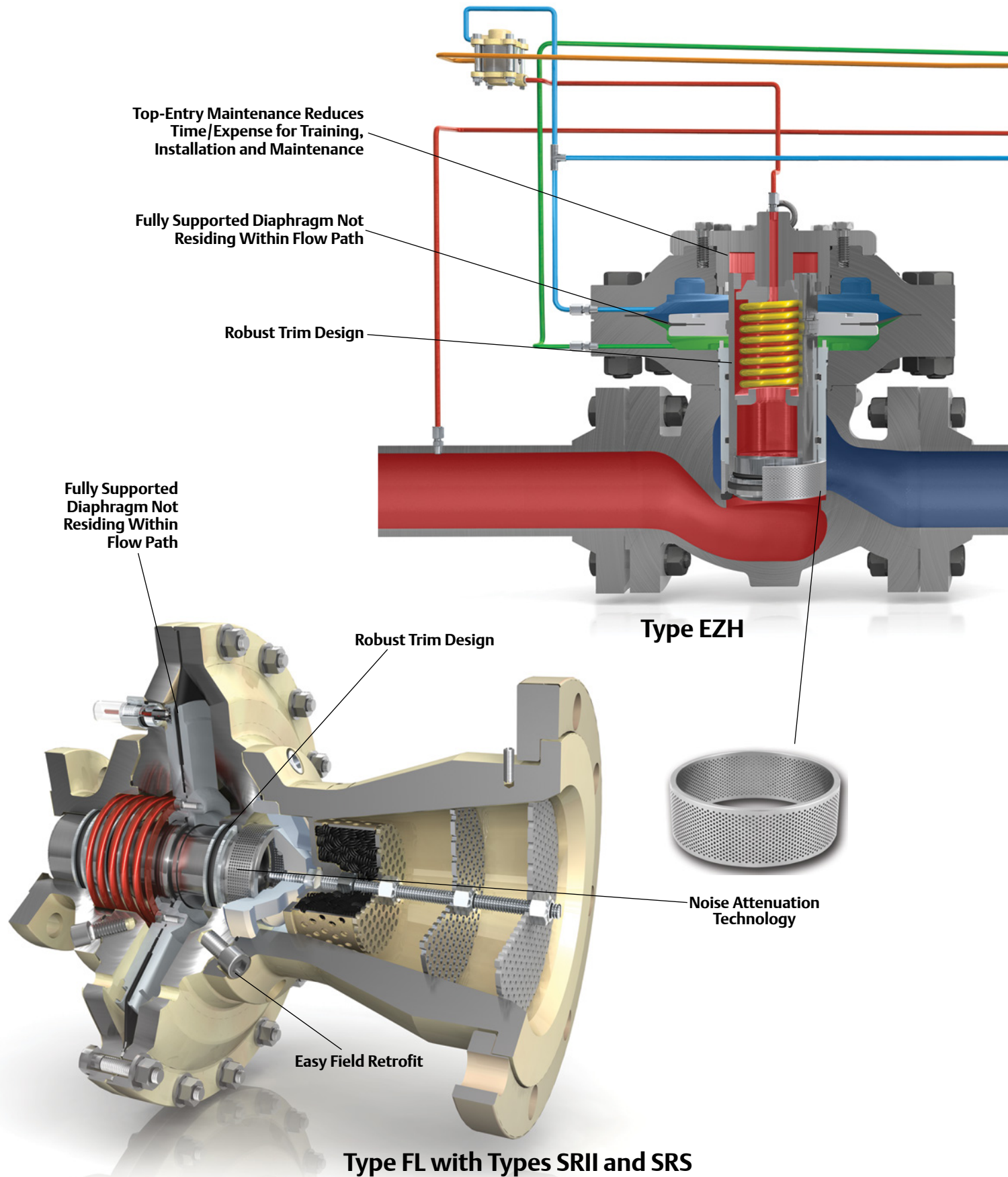

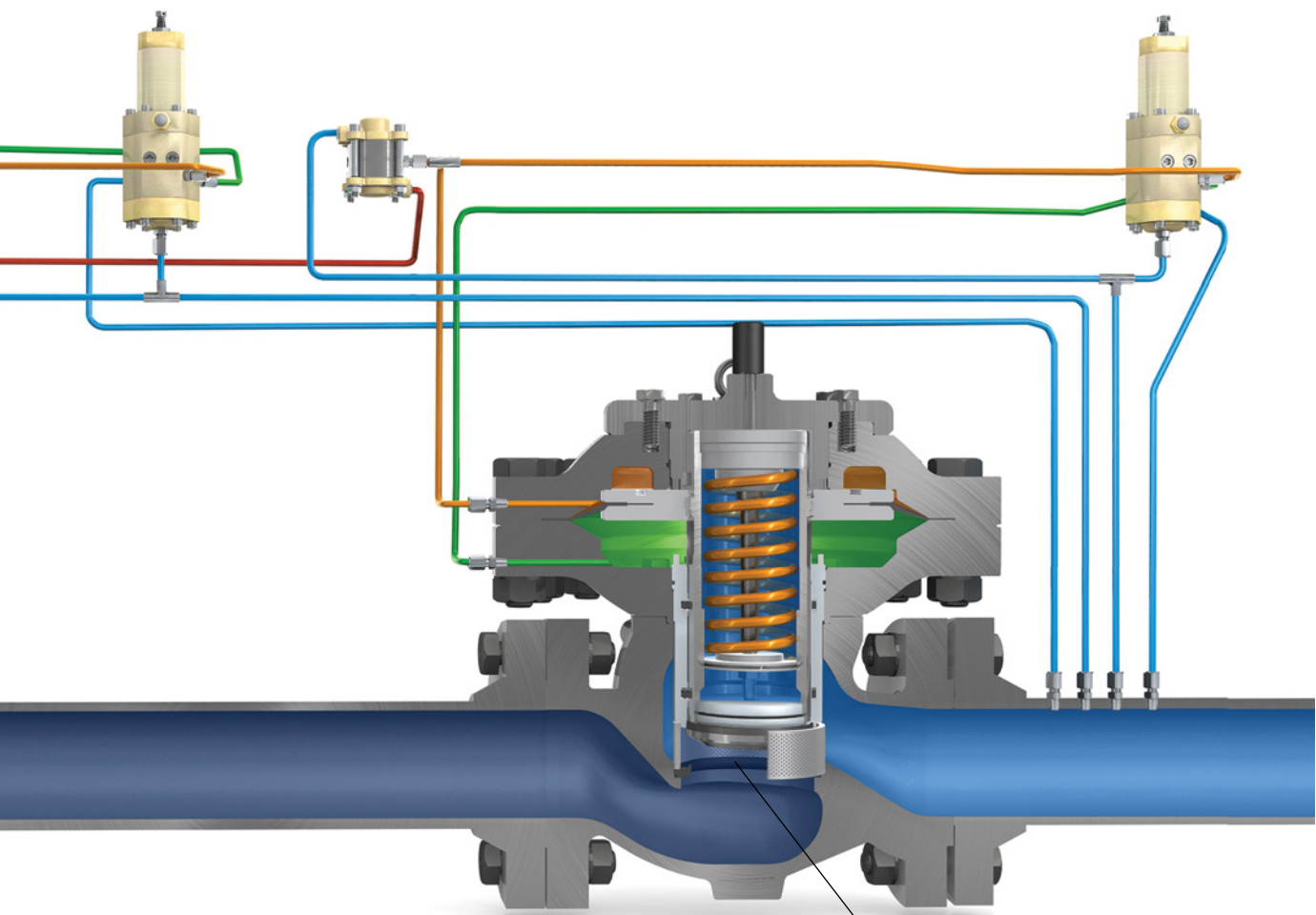

Type EZHSO

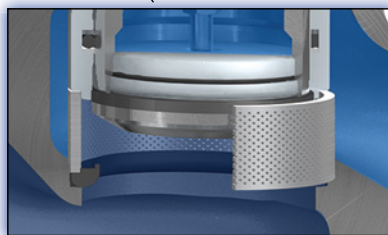

Fails in open position in case of main valve diaphragm failure or lack of pressure to the pilot. Meets EU EN334.

Source Treatment Efficiency

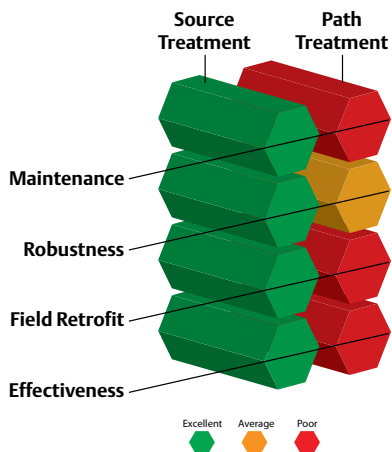

Source Treatment to Path Treatment

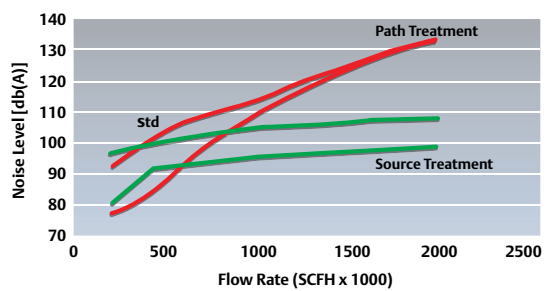

Due to high pressure-drop ratios, aerodynamic noise is generated by the turbulence created in the flow stream as gas travels through the port. Source treatment with our Noise Attenuation Technology utilizes multiple orifices of special size, shape and spacing, reducing noise-producing interactions.

Engineered, Designed and Tested to Meet Customers' Expectations

We are known for products with rugged construction, easy maintenance and overall reliability. We've taken the input of industry professionals and added features to improve the practical application of transmission regulators.

Meet Higher System Requirements

EZH/FL Series
*Operates up to 103 bar /
1500 psig inlet pressure*

FL Series
*High C_g
and higher capacities*

Eliminate Emissions

EZH/FL Series
No bleed technology

*Environmentally friendly
design for higher pressure
pipelines*

Reduce Ownership Cost

EZH/FL Series
*Reduce cost of ownership
by eliminating bleed of gas*

*Robust trim design due to metal plug design,
new trim design, and fully supported diaphragm
that does not reside within flow path*

*Multiple body sizes and configurations to fit new
and replacement applications*

Longer service life

EZH Series
Top-entry maintenance

Ensure Gas Delivery

Type EZHSO
*Offers a fail-open alternative
maximizing uptime*

Reduce Noise Output

EZH/FL Series
More efficient source treatment

Easy field retrofit

**Emerson Process Management
Regulator Technologies, Inc.**

Americas

Worldwide Headquarters

3200 Emerson Way
McKinney, Texas 75070 USA
T: +1 800 558 5853
T: +1 972 548 3574
F: +1 972 542 6433

TESCOM Corporation

12616 Industrial Boulevard
Elk River, Minnesota 55330-2445 USA
T: +1 800 447 1250
T: +1 763 241 3238
F: +1 763 241 3224

For further information visit www.emersonprocess.com/regulators

D351755X012 © 2011, 2014 Emerson Process Management Regulator Technologies, Inc. All rights reserved. Printed in the U.S.A.
04/14. Fisher, Tartarini, Francel, Emerson Process Management, and the Emerson Process Management design are marks of one
of the Emerson Process Management group of companies. All other marks are the property of their respective owners.

**Emerson Process Management
Regulator Technologies, Inc.**

Europe

Natural Gas: T: +39 051 419 0611
Industrial: T: +39 051 419 0606
LP-Gas: T: +420 2 710 35 607
TESCOM: T: +49 (0) 38823 31 0

**Emerson Process Management
Regulator Technologies, Inc.**

Asia Pacific

Natural Gas: T: +65 6770 8337
Industrial: T: +86 21 2892 9000

Middle East

T: +011 971 4811 8100

Our Global Product Brands:

