

Fisher® 1061 Pneumatic Piston Rotary Actuator

Fisher 1061 pneumatic piston rotary actuators are used to operate splined-shaft rotary control valves such as Vee-Ball™ valves, eccentric disc valves, and butterfly valves. The actuator/valve body linkage of this actuator can be positioned for either push-down-to-open or push-down-to-close action.

Additionally, the 1061 actuator can be used with a two-position control signal for on-off service or with a valve positioner for throttling service. An optional handwheel actuator is also available to allow for auxiliary or emergency manual valve operation when the 1061 piston actuator is not in use. For complete information on the valve positioner and the manual handwheel actuator, refer to the appropriate bulletin.



W8380-2

1061 Actuator with FIELDVUE™ DVC6200 Digital Valve Controller Mounted on a Fisher V500 Valve

Features

- **Application Flexibility**—Actuator is available in push-down-to-open or push-down-to-close construction and may be mounted in any of four actuator/valve body mounting positions (see figure 2).
- **Minimal Dead Band**—Single-point linkage with splined and clamped lever minimizes lost motion and improves control accuracy.
- **Compact Construction**—Compared to similar actuators, overall size is reduced by as much as 30 percent.
- **Long Service Life**—Rugged construction provides stability, corrosion resistance, and protection from deformation should the actuator be over-pressured.
- **Accessibility**—Actuator/valve body linkage is completely enclosed, yet the valve packing adjustment remains accessible without removing any parts.
- **Monitoring Ease**—Highly visible travel indicator allows easy determination of valve position.



Specifications

Available Configuration

Actuator Sizes: ■ 30, ■ 40, ■ 60, ■ 68, ■ 80, ■ 100, and ■ 130

Action: Double-acting pneumatic piston rotary actuator for ■ throttling service when used with positioner, or ■ on-off service when used with switching devices

Cylinder Operating Pressure

Minimum Recommended: ■ 1.4 bar (20 psig) without positioner, or ■ 0.35 bar (5 psi) above actuator requirement with positioner⁽¹⁾.

Maximum Allowable⁽²⁾

Sizes 30 and 60: 6.9 bar (100 psig)
Size 40: 10.3 bar (150 psig)
Size 68: 5.9 bar (85 psig)
Size 80: 10.3 bar (150 psig)
Size 100: 10.3 bar (150 psig)
Size 130: 10.3 bar (150 psig)

Valve Shaft Diameters, mm (Inch)

Size 30: ■ 12.7 (1/2), ■ 15.9 (5/8), ■ 19.1 (3/4), ■ 22.2 (7/8), ■ 25.4 (1), and ■ 31.8 (1-1/4)
Sizes 40, 60, and 68: ■ 19.1 (3/4), ■ 22.2 (7/8), ■ 25.4 (1), ■ 31.8 (1-1/4), ■ 38.1 (1-1/2), ■ 44.5 (1-3/4), and ■ 50.8 (2)
Sizes 80 and 100: ■ 44.5 (1-3/4), ■ 50.8 (2), and ■ 63.5 (2-1/2)
Size 130: ■ 76.2 (3) and ■ 88.9 (3-1/2)

Maximum Valve Shaft Rotation

■ 90 degrees without travel stop or ■ 60 degrees with optional travel stop

Maximum Breakout Torque⁽¹⁾

Size 30: Up to 282 N•m (2500 lbf•in)
Size 40: Up to 847 N•m (7500 lbf•in)
Size 60: Up to 1130 N•m (10,000 lbf•in)
Size 68: Up to 1540 N•m (13,600 lbf•in)
Size 80: Up to 5080 N•m (45,000 lbf•in)
Size 100: Up to 6290 N•m (55,700 lbf•in) with 63.5 mm (2-1/2 in.) valve shaft diameter

Size 130: Up to 19,800 N•m (175,000 lbf•in)

Stroking Time

Dependent on actuator size, rotation, and positioner if used. If stroking time is critical, consult your Emerson Process Management sales office.

Construction Materials

Cylinder and Cylinder Flange: Aluminum

Housing Cover: ■ Cast iron or ■ aluminum (only for size 130)

Piston: ■ Aluminum or ■ Nylon-coated piston (optional only for sizes 30 to 100)

Piston Rod: Chrome-plated stainless steel

Lever: Ductile iron

Sliding Seal: Aluminum

O-Rings: Nitrile

Housing:

Sizes 30, 40, 60, and 68: Cast iron
Sizes 80, 100 and 130: Aluminum

Mounting Yoke: Cast iron

Mounting Yoke Bushing: PTFE and steel

Material Temperature Capabilities with Standard Elastomers⁽²⁾

-34 to 82°C (-30 to 180°F)

Pressure Connections

1/4 NPT internal, and for optional pipe-away vent, 3/4 NPT internal connection
 Size 130 uses 1 NPT internal connection. See table 1

Travel Indication

Graduated scale and pointer located on actuator end of valve shaft

Mounting Positions

See figure 2

Approximate Weight

See table 2

1. Actual actuator torque available depends on specific construction and casing pressure. For information on torque requirements of the valve being considered, contact your Emerson Process Management sales office.
 2. The pressure/temperature limits in this manual and any applicable standard or code limitation for actuator should not be exceeded.

Figure 1. Sectional of Fisher 1061 Actuator

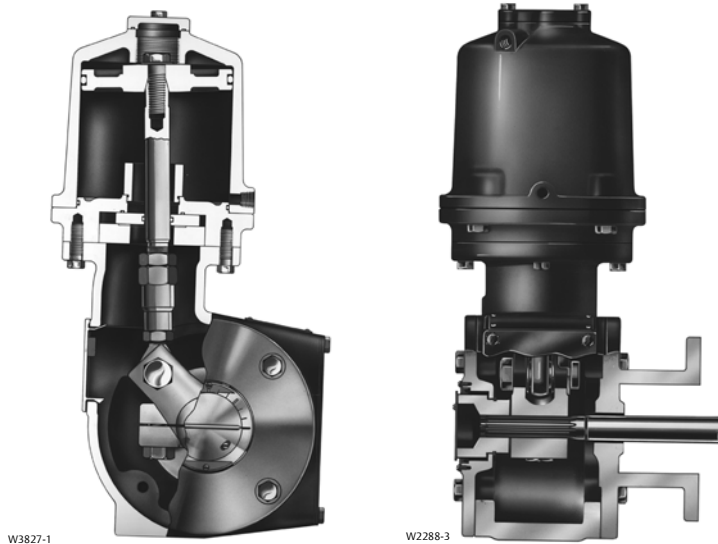

Table 1. Displacement for 90 Degree Rotation

SIZE	PISTON DOWN		PISTON UP	
	cm ³	Inch ³	cm ³	Inch ³
30	1100	67	1200	74
40	2130	130	2230	136
60	4060	248	4380	267
68	7210	440	7110	434
80	13,000	794	12,900	788
100	19,100	1165	18,800	1150
130	41,100	2508	40,200	2454

Table 2. Approximate Weight

ACTUATOR SIZE	kg	Lb
30	22	49
40	29	63
60	39	86
68	56	123
80	122	246
100	135	298
130	299	660

Options

Pneumatic Instruments: ■ 3710, ■ 3610JP, or ■ 3620JP pneumatic or electro-pneumatic positioners or ■ FIELDVUE DVC6200 Digital Valve Controllers are available. Also, the 377 Series trip valves are available with ■ lock-in-last position, ■ fail-up, or ■ fail-down action (for specifications, see separate bulletins).

Potentiometer: It is used for remote valve rotation indication.

Limit Switches: ■ TopWorx™ DXP M21GNEB limit switch for one through six single-pole, double-throw contacts (see separate bulletin), ■ GO™ proximity switches for one or two single-pole, double-throw contacts, or ■ Micro-Switches or NAMCO switches for one or two single-pole, double-throw or double-pole, double-throw contacts. GO proximity switch are not available for size 80, 100 or 130 actuators.

Handwheel Actuator: The Fisher 1078 manual declutchable actuator (see figure 3) allows auxiliary or emergency valve operation of sizes 30 through 100 when engaged (see bulletin 61.8:1078).

Cylinder Bypass: The bypass valve is required when a handwheel actuator is specified.

Locking Mechanism: The locking mechanism shown in figure 4 is available for sizes ■ 30, ■ 40, ■ 60, and ■ 68 actuators. The locking mechanism shown in figure 5 is available for sizes ■ 80 and ■ 100 actuators.

FlowScanner™ Connections: Optional quick disconnect connections are available for use with the portable FlowScanner microprocessor-based diagnostic testing unit.

Pipe-Away Vent: Some applications use natural gas or other hazardous gases as a supply pressure to the actuator. These applications require the actuator housing to be vented, reducing the accumulation of gases. For new constructions and retrofit kit information, contact your Emerson Process Management sales office with complete service conditions.

Table 3. Mounting Styles and Positions

MOUNTING	ACTION ⁽¹⁾	VALVE SERIES OR DESIGN				VALVE SERIES OR DESIGN		
		BALL/PLUG ROTATION TO CLOSE	V250	V150, V200 and V300	CV500 and V500	DISC/BALL ROTATION TO CLOSE	V250	8510B, 8532, 8560 and 9500
Right-Hand	PDTC	CCW	A	A	A	CW	NA	B
	PDTO	CCW	B	B	B	CW	NA	A
Left-Hand	PDTC	CCW	NA	D	D	CW	C	C
	PDTO	CCW	NA	C	C	CW	D	D
Left-Hand (Optional) ⁽²⁾	PDTC	CW	NA	C	NA	NA	NA	NA
	PDTO	CW	NA	D	NA	NA	NA	NA

1. PDTC—Push-down-to-close, and PDTO—Push-down-to-open.
2. A left hand ball will be required for the 3- through 12-inch Series B and the 14- to 20-inch, with or without attenuator.

Figure 2. Mounting Styles and Positions (also see table 3)

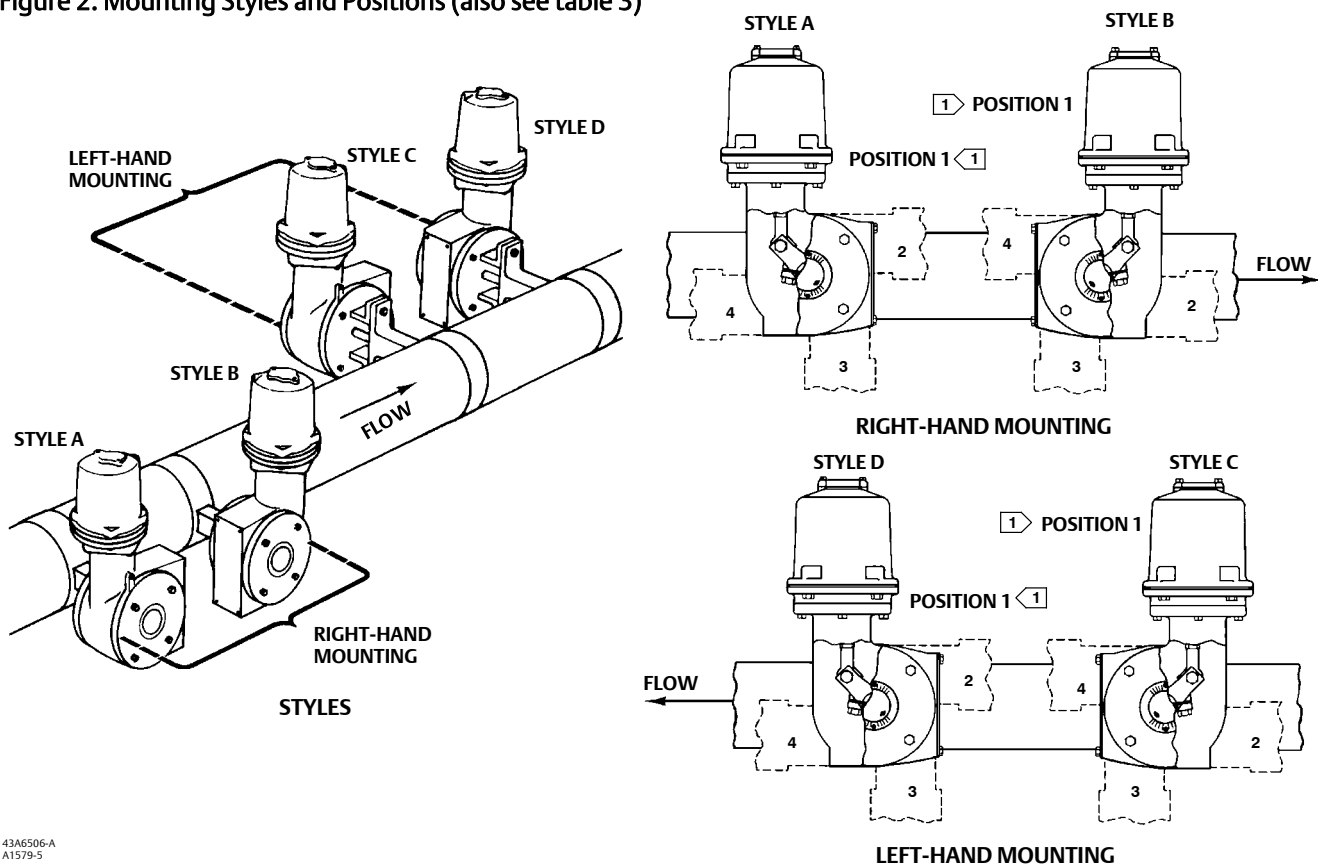

43A6506-A
A1579-5

Notes:

1. Position 1 is standard; positions 2 through 4 (shown in dotted lines) are alternates.

2. By Emerson Process Management definition:

- Forward flow is into the face side of the disc, or ball sealing surface.
- Reverse flow is into the hub side of the disc or ball.

Installation

The actuator is normally positioned vertically in a horizontal pipeline. However, four mounting styles and four positions are possible for each style (see figure 2).

When looking in the direction of flow in the pipeline, an actuator is right-hand mounted when it is on the right side of the pipeline, and an actuator is left-hand mounted when it is mounted on the left side of the pipeline.

Figure 3. Fisher 1078 Declutchable Manual Actuator

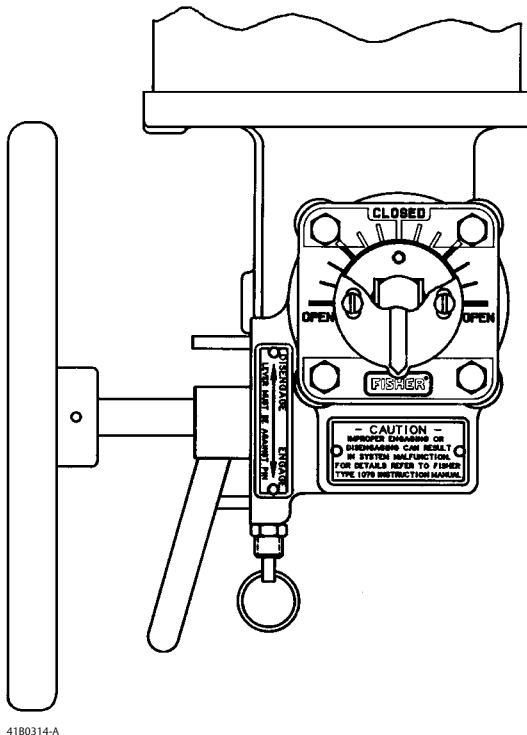

By Emerson Process Management definition, forward flow is into the face side of the disc or ball, and reverse flow is into the hub side of the disc or ball.

Dimensions for the 1061 actuator are shown in figure 6. These dimensions should be used in conjunction with the mounting positions shown in figure 2.

Actuator Locking Mechanism

The 1061 actuator (sizes 30 through 100) is available with a locking mechanism which may be used to keep the actuator in the locked position during maintenance shutdowns (see figures 4 and 5). The device is intended to prevent accidental operation of the valve during shutdown and does not imply or qualify a control valve as a safety shutdown device.

Adjustable Travel Stops

An adjustable down travel stop for the 1061 size 30, 40, 60, and 68 actuators is installed in a special actuator housing. The assembly consists of locking screws, locknut, special end rod bearing, and special lever.

As used here, down or downward means in a direction toward the valve shaft and away from the piston and diaphragm. Up or upward means in a direction away from the valve shaft and toward the piston and diaphragm.

The locking screw can be positioned to limit downward travel of the actuator lever to any rotation between 0 and 90 degrees. The travel stop is installed similar to the locking mechanism shown in figure 4, except the travel stop does not accommodate a padlock and the travel stop can be completely unscrewed from the housing.

An adjustable up travel stop for the 1061 sizes 40 through 100 actuators is installed in the top of a special actuator cylinder. The top of the special cylinder is tapped and faced (machined) for the travel stop. The assembly consists of a screw, locknut, and pressure seal. The screw can be positioned to limit upward travel of the piston to any rotation between 30 and 90 degrees. Longer screws are available to further limit travel.

Figure 4. Actuator Locking Mechanism for Size 30, 40, 60, and 68 Actuators

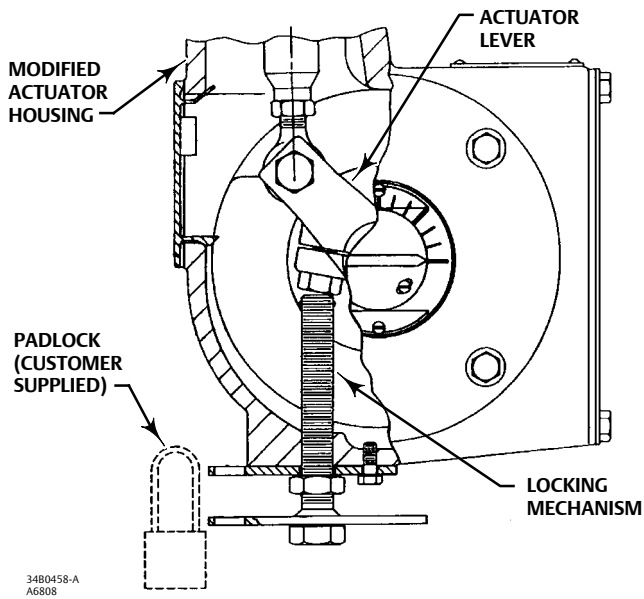

Figure 5. Actuator Locking Mechanism for Size 80 and 100 Actuators

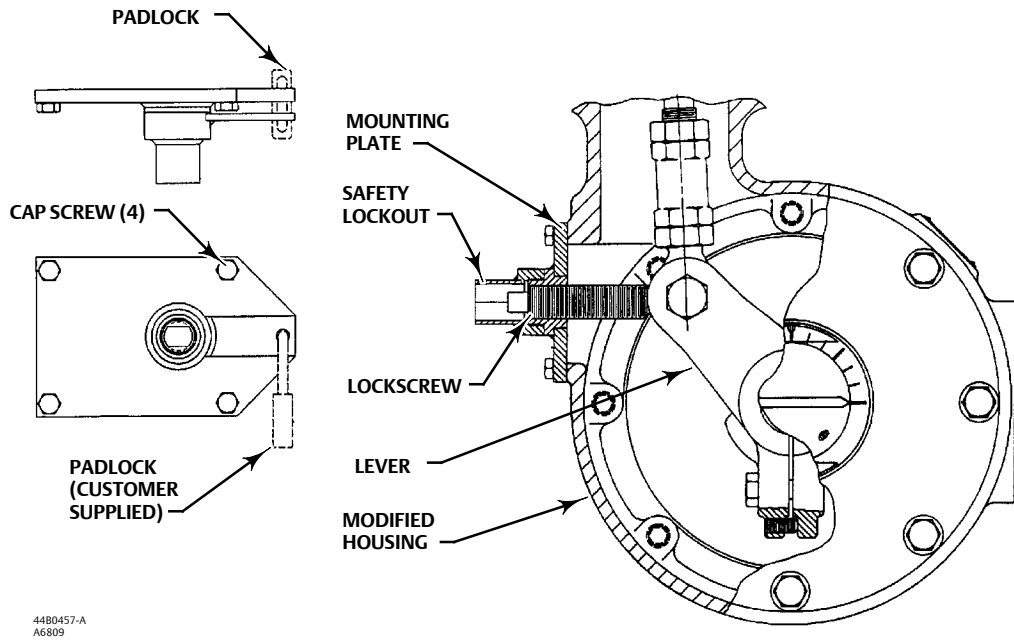

Table 4. Dimensions

ACTUATOR SIZE	C		E		F		H		P				Y	
	mm	Inches	mm	Inches	mm	Inches	mm	Inches	w/o Positioner		w/3610JP Pos.		mm	Inches
									mm	Inches	mm	Inches		
30	171	6.75	378	14.88	53.8	2.12	114	4.50	175	6.88	281	11.07	73.2	2.88
40	206	8.12	425	16.75	63.5	2.50	121	4.75	186	7.31	292	11.50	76.2	3.00
60	267	10.50	406	16.00	63.5	2.50	121	4.75	186	7.31	292	11.50	76.2	3.00
68	324	12.75	483	19.00	63.5	2.50	121	4.75	186	7.31	292	11.50	76.2	3.00
80	324	12.75	714	28.12	123	4.84	213	8.38	345	13.62	452	17.81	127	5.00
100	381	15.00	714	28.12	123	4.84	213	8.38	345	13.62	452	17.81	127	5.00
130	489	19.24	926	36.47	169	6.67	291	11.46	471	18.55	578	22.74	167	6.56

Table 5. Dimensions

VALVE SHAFT DIAMETER		STYLE F MOUNTING: V-LINE, 8532, 8560, AND ECCENTRIC DISC VALVES						STYLE G MOUNTING: 9500 SERIES VALVES						V	
		T		U		W		T		U		W			
mm	Inches	mm	Inches	mm	Inches	mm	Inches	mm	Inches	mm	Inches	mm	Inches	mm	Inches
12.7	1/2	117	4.62	- - -	- - -	14.3	0.56	117	4.62	- - -	- - -	11.1	0.44	137	5.38
15.9	5/8	117	4.62	- - -	- - -	14.3	0.56	146	5.75	31.7	1.25	11.1	0.44	137 ⁽¹⁾	5.38 ⁽¹⁾
19.1 and 25.4	3/4 and 1	152	6.00	31.7	1.25	14.3	0.56	146	5.75	31.7	1.25	11.1	0.44	160	6.31
31.8 and 38.1	1-1/4 and 1-1/2	235	9.25	45.9	1.81	17.5	0.69	210	8.25	50.8	2.00	17.5	0.69	148	5.81
44.5 and 50.8	1-3/4 and 2	273	10.75	50.8	2.00	20.5	0.81	241	9.50	69.8	2.75	17.5	0.69	286 ⁽²⁾	11.25 ⁽²⁾
63.5	2-1/2	337	13.25	76.2	3.00	23.8	0.94	- - -	- - -	- - -	- - -	- - -	- - -	235	9.25
76.2	3 ⁽³⁾	533	21.00	127	5.00	33.5	1.32	- - -	- - -	- - -	- - -	- - -	- - -	322	12.68
88.9	3-1/2 ⁽³⁾	533	21.00	127	5.00	33.5	1.32	- - -	- - -	- - -	- - -	- - -	- - -	322	12.68

1. Dimension shown is for eccentric disc, V150, V200, V300, CV500, 8532, and 8560 valves only; For 7600 and 9500 valves, dimension "V" is 160 mm (6.31 inches).
 2. Dimension shown is for size 60 and 68 actuators only; for Size 80 and 100 actuators, the dimension "V" is 235 mm (9.25 inches).
 3. Dimensions shown are for V260 valves only.

Figure 6. Dimensions (also see tables 4 and 5)

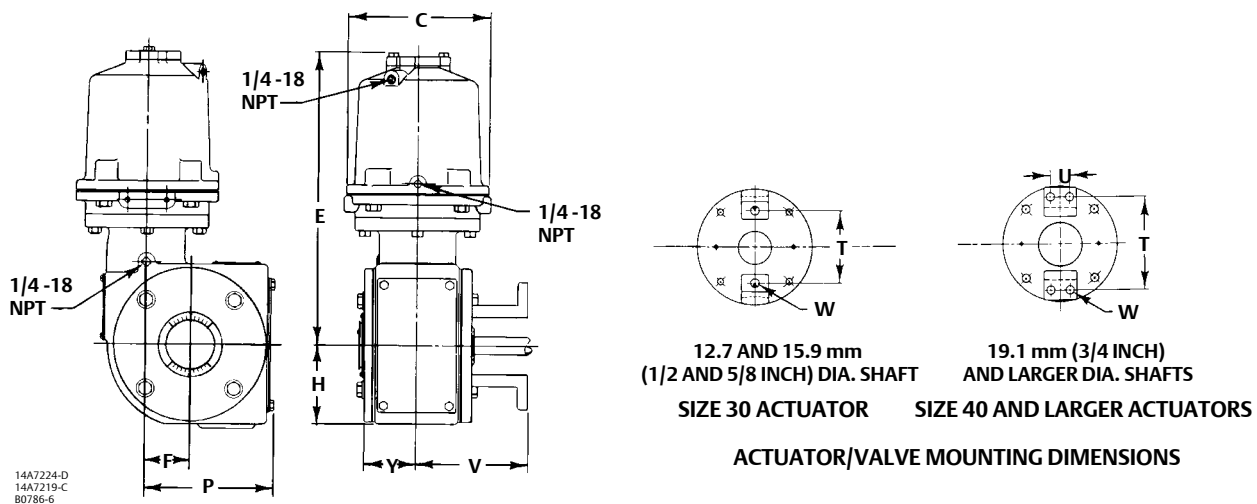

Neither Emerson, Emerson Process Management, nor any of their affiliated entities assumes responsibility for the selection, use or maintenance of any product. Responsibility for proper selection, use, and maintenance of any product remains solely with the purchaser and end user.

Fisher, Vee-Ball, FIELDVUE, TopWorx, GO, and FlowScanner are marks owned by one of the companies in the Emerson Process Management business unit of Emerson Electric Co. Emerson Process Management, Emerson, and the Emerson logo are trademarks and service marks of Emerson Electric Co. All other marks are the property of their respective owners.

The contents of this publication are presented for informational purposes only, and while every effort has been made to ensure their accuracy, they are not to be construed as warranties or guarantees, express or implied, regarding the products or services described herein or their use or applicability. All sales are governed by our terms and conditions, which are available upon request. We reserve the right to modify or improve the designs or specifications of such products at any time without notice.

Emerson Process Management

Marshalltown, Iowa 50158 USA
Sorocaba, 18087 Brazil
Chatham, Kent ME4 4QZ UK
Dubai, United Arab Emirates
Singapore 128461 Singapore

www.Fisher.com