

Fisher® 249 Sensor, Level Controller, and Transmitter Dimensions

This bulletin contains dimensional information for Fisher displacer-type sensors and for controllers and transmitters used with these sensors. Dimensions are subject to change and certified dimensions should be requested for construction projects. Some of the abbreviations used in this document are as follows: NPT = National Pipe Thread, NPS = Nominal Pipe Size, FF = Flat Face Flange, RF = Raised Face Flange, and RTJ = Ring Type Joint Flange.

Flange specification references are ASME B16.1 for CL125 and 250 and ASME 16.5 for CL150, 300, 600, 900, 1500 and 2500.

Contents

Caged Displacer for External Vessel Mounting

249: figure 1 and 2; tables 1, 2, 3, and 4

249B and 249BF: figure 3; tables 5, 6, 7, and 8

249C and 249K: figure 4; tables 9, 10, and 11

249L: figure 5

Cageless Displacer for Internal Vessel Mounting

Top Mounted

249BP and 249P: figure 6; tables 12 and 13

249CP: figure 7; tables 14 and 15

Side Mounted

249VS: figure 8, 9, 10, and 11

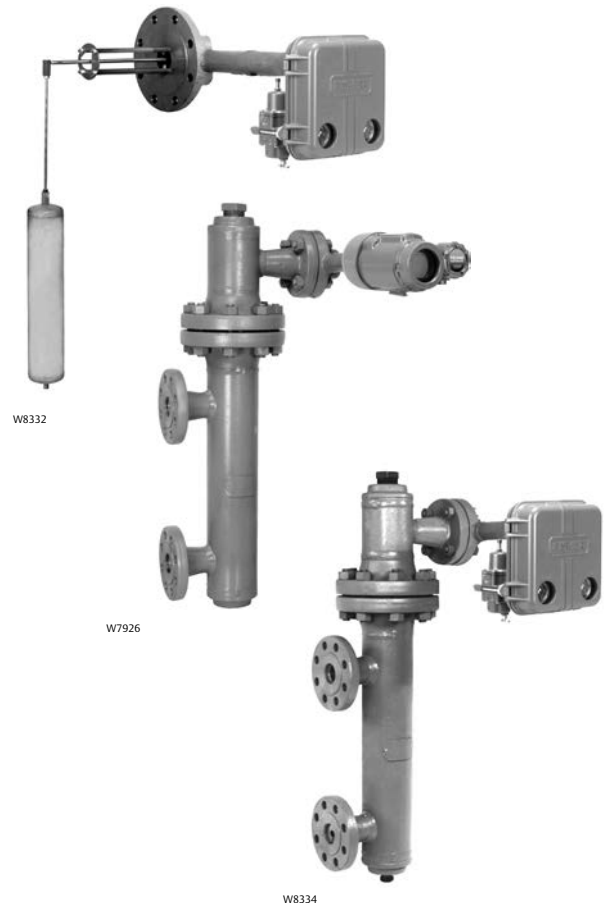

Cageless Displacer for Mounting on Customer Supplied Cage or on Top of Vessel

249W: figure 12

Controllers and Transmitters

Fisher 2500 Controller / Transmitter: figure 13

FIELDVUE™ DLC3010 / DLC3020f Digital Level Controller: figure 14



249

Figure 1. Fisher 249 Top View

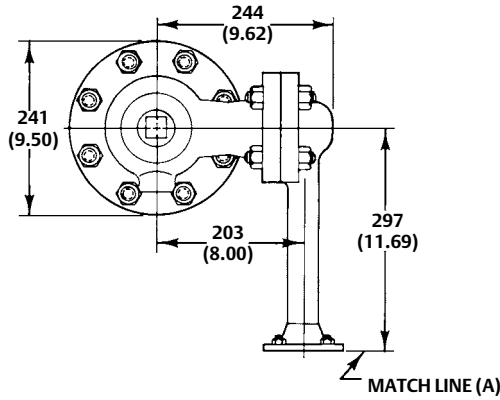

A1323-1

TOP VIEW

mm
(INCH)

Table 1. Fisher 249 Dimensions F, M, and W for S-1 and F-1 Connections⁽¹⁾

Displacer Length	S-1 AND F-1 CONNECTIONS						W
	F			M			
	CL125 FF	Scrd NPT	CL250 RF	Scrd NPT	CL125 FF	CL250 RF	
mm							
356	562	495	575	241	279	286	406
813	1019	953	1032	470	508	514	864
Inches							
14	22.12	19.50	22.62	9.50	11.00	11.25	16.00
32	40.12	37.50	40.62	18.50	20.00	20.25	34.00

1. Scrd is 1-1/2 and 2 NPT. Flanges in NPS 2 only.

Table 2. Fisher 249 Dimensions F, M, and W for S-2 Connections

S-2 CONNECTIONS: 1-1/2 NPT, CL250							
Displacer Length		F		M		W	
mm	Inch	mm	Inch	mm	Inch	mm	Inch
356	14	657	25.88	241	9.50	394	15.5

Table 4. Fisher 249 Dimensions F, M, and W for S-4 Connections

S-4 CONNECTIONS: 1-1/2 NPT, CL250							
Displacer Length		F		M		W	
mm	Inch	mm	Inch	mm	Inch	mm	Inch
356	14	445	17.50	241	9.50	394	15.5

Table 3. Fisher 249 Dimensions F, M, and W for S-3 Connections

S-3 CONNECTIONS: 1-1/2 NPT, CL250							
Displacer Length		F		M		W	
mm	Inch	mm	Inch	mm	Inch	mm	Inch
356	14	356	14.00	241	9.50	394	15.5

Figure 2. Fisher 249 Side View (see tables 1, 2, 3, and 4)

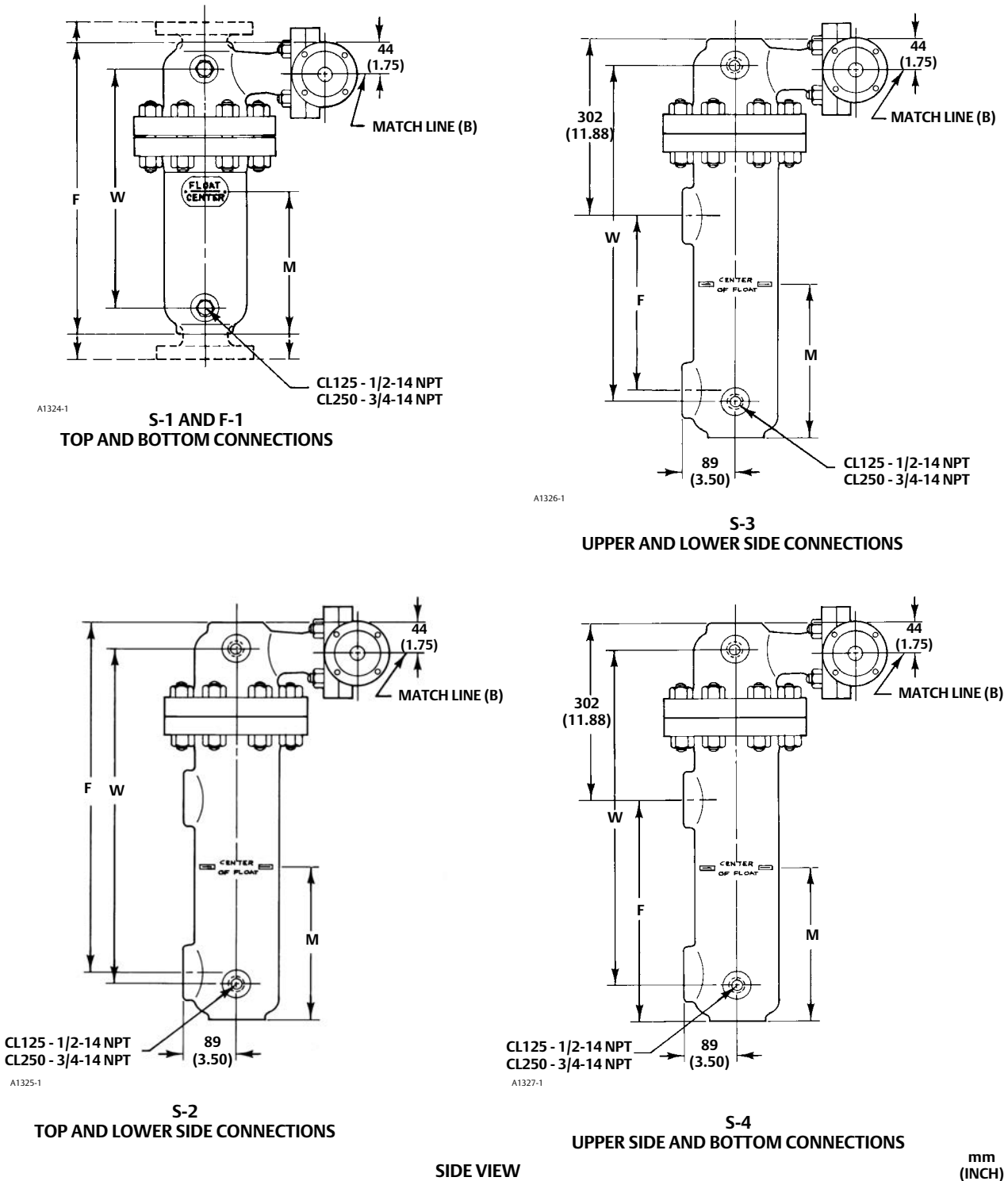

249B and 249BF (NPS 1-1/2 and 2 End Connections)

Figure 3. Fisher 249B and 249BF (see tables 5, 6, 7, and 8)

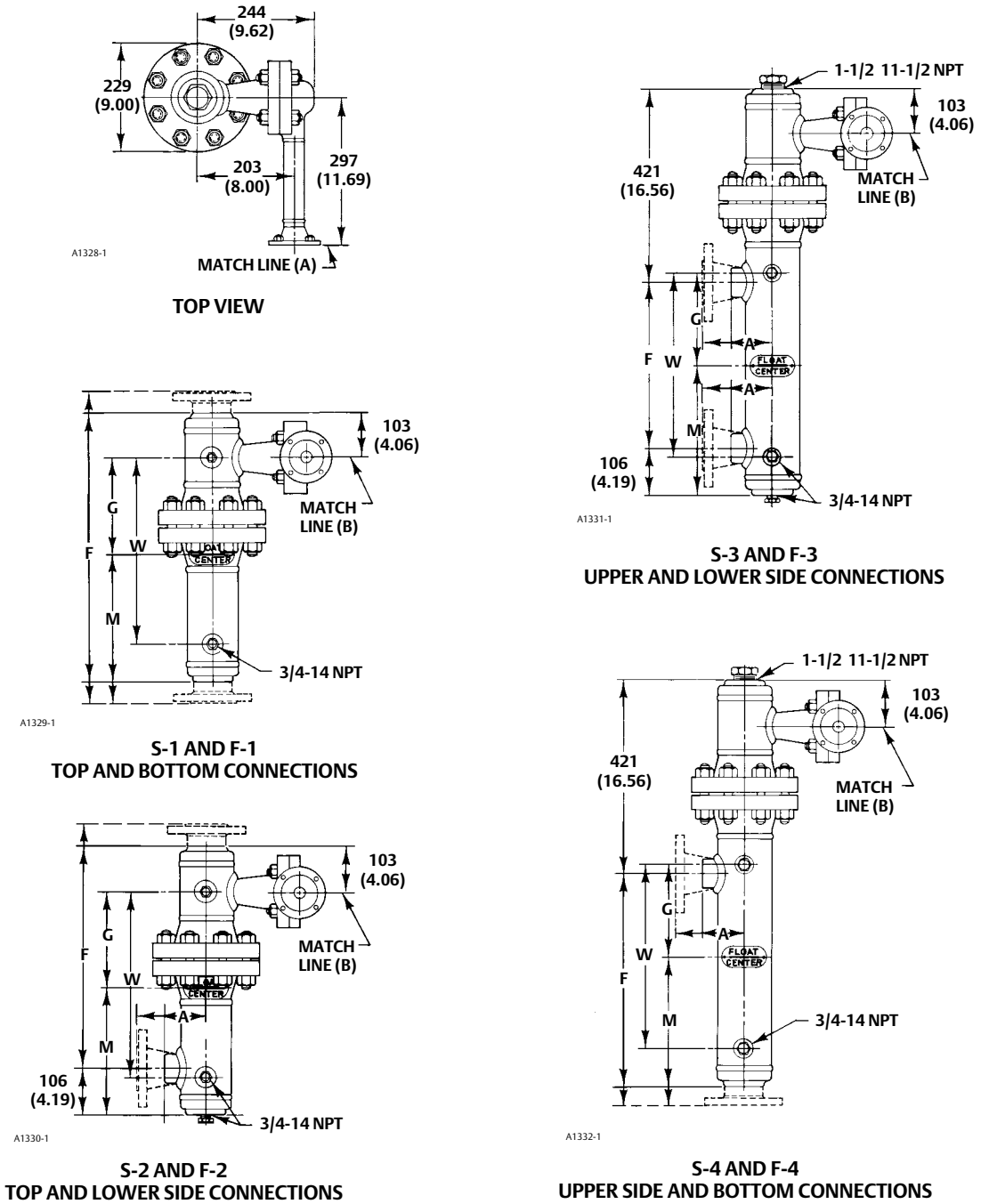

mm
(INCH)

SIDE VIEW

Table 5. Fisher 249B and 249BF S-1, F-1, S-4, and F-4 Connections

Conn. Style	Dis-placer Length	F							M						
		Scrd NPT	CL150		CL300		CL600		Scrd NPT	CL150		CL300		CL600	
			RF	RTJ	RF	RTJ	RF	RTJ		RF	RTJ	RF	RTJ	RF	RTJ
S-1 and F-1 (mm)	356	586	662	675	668	684	687	691	284	322	329	325	333	335	337
	813	1043	1119	1132	1126	1141	1145	1148	513	551	557	554	562	564	565
	1219	1449	1526	1538	1532	1548	1551	1554	716	754	760	757	765	767	768
	1524	1754	1830	1843	1836	1853	1856	1859	866	907	913	910	917	919	921
	1829	2058	2135	2148	2141	2157	2160	2164	1021	1059	1065	1062	1070	1072	1073
	2134	2364	2440	2453	2446	2462	2465	2469	1173	1211	1218	1214	1222	1224	1226
	2438	2669	2745	2757	2751	2767	2770	2773	1326	1364	1370	1367	1375	1376	1378
	2743	2973	3050	3062	3056	3072	3075	3078	1478	1516	1522	1519	1527	1529	1530
	3048	3278	3354	3367	3361	3377	3380	3383	1630	1669	1675	1672	1679	1681	1683
	S-1 and F-1 (Inch)	14	23.06	26.06	26.56	26.31	26.94	27.06	27.19	11.19	12.69	12.94	12.81	13.12	13.19
32		41.06	44.06	44.56	44.31	44.94	45.06	45.19	20.19	21.69	21.94	21.81	22.12	22.19	22.25
48		57.06	60.06	60.56	60.31	60.94	61.06	61.19	28.19	29.69	29.94	29.81	30.12	30.19	30.25
60		69.06	72.06	72.56	72.31	72.94	73.06	73.19	34.19	35.69	35.94	35.81	36.12	36.19	36.25
72		81.06	84.06	84.56	84.31	84.94	85.06	85.19	40.19	41.69	41.94	41.81	42.12	42.19	42.25
84		93.06	96.06	96.56	96.31	96.94	97.06	97.19	46.19	47.69	47.94	47.81	48.12	48.19	48.25
96		105.06	108.06	108.56	108.31	108.94	109.06	109.19	52.19	53.69	53.94	53.81	54.12	54.19	54.25
108		117.06	120.06	120.56	120.31	120.94	121.06	121.19	58.19	59.69	59.94	59.81	60.12	60.19	60.25
120		129.06	132.06	132.56	132.31	132.94	133.06	133.19	64.19	65.69	65.94	65.81	66.12	66.19	66.25
S-4 and F-4 (mm)		356	462	500	506	503	511	513	514	284	322	329	325	333	335
	813	919	957	964	960	968	970	972	513	551	557	554	562	564	565
	1219	1326	1364	1370	1367	1375	1376	1378	716	754	760	757	765	767	768
	1524	1630	1669	1675	1672	1679	1681	1683	866	907	913	910	917	919	921
	1829	1935	1973	1980	1976	1984	1986	1988	1021	1059	1065	1062	1070	1072	1073
	2134	2240	2278	2284	2281	2288	2291	2292	1173	1211	1218	1214	1222	1224	1226
	2438	2545	2583	2589	2586	2593	2596	2597	1326	1364	1370	1367	1375	1376	1378
	2743	2850	2888	2894	2891	2899	2900	2902	1478	1516	1522	1519	1527	1529	1530
	3048	3154	3193	3199	3196	3203	3265	3267	1630	1669	1675	1672	1679	1681	1683
	S-4 and F-4 (Inch)	14	18.19	19.69	19.94	19.81	20.12	20.19	20.25	11.19	12.69	12.94	12.81	13.12	13.19
32		36.19	37.69	37.94	37.81	38.12	38.19	38.25	20.19	21.69	21.94	21.81	22.12	22.19	22.25
48		52.19	53.69	53.94	53.81	54.12	54.19	54.25	28.19	29.69	29.94	29.81	30.12	30.19	30.25
60		64.19	65.69	65.94	65.81	66.12	66.19	66.25	34.19	35.69	35.94	35.81	36.12	36.19	36.25
72		76.19	77.69	77.94	77.81	78.12	78.19	78.25	40.19	41.69	41.94	41.81	42.12	42.19	42.25
84		88.19	86.69	89.94	89.81	90.12	90.19	90.25	46.19	47.69	47.94	47.81	48.12	48.19	48.25
96		100.19	101.69	101.94	101.81	102.12	102.19	102.25	52.19	53.69	53.94	53.81	54.12	54.19	54.25
108		112.19	113.69	113.94	113.81	114.12	114.19	114.25	58.19	59.69	59.94	59.81	60.12	60.19	60.25
120		124.19	125.69	125.94	125.81	126.12	126.19	126.25	64.19	65.69	65.94	65.81	66.12	66.19	66.25

Table 6. Fisher 249B and 249BF S-2, F-2, S-3, and F-3 Connections

S-2 AND F-2 CONNECTIONS								S-3 AND F-3 CONNECTIONS		
F								M	F	M
Displacer Length	Scrd NPT	CL150		CL300		CL600				
		RF	RTJ	RF	RTJ	RF	RTJ			
mm	mm									
356	480	518	524	521	529	530	532	284	356	284
813	937	975	981	978	986	988	989	513	813	513
1219	1343	1381	1387	1384	1392	1394	1395	716	1219	716
1524	1648	1686	1692	1689	1697	1699	1700	866	1524	866
1829	1953	1991	1997	1994	2002	2004	2005	1021	1829	1021
2134	2258	2296	2302	2299	2307	2308	2310	1173	2134	1173
2438	2562	2600	2607	2604	2611	2613	2615	1326	2438	1326
2743	2867	2905	2911	2908	2916	2918	2919	1478	2743	1478
3048	3172	3210	3216	3213	3221	3223	3224	1630	3048	1630
Inches	Inches									
14	18.88	20.38	20.62	20.50	20.81	20.88	20.94	11.19	14.00	11.19
32	36.88	38.38	38.62	38.50	38.81	38.88	38.94	20.19	32.00	20.19
48	52.88	54.38	54.62	54.50	54.81	54.88	54.94	28.19	48.00	28.19
60	64.88	66.38	66.62	66.50	66.81	66.88	66.94	34.19	60.00	34.19
72	76.88	78.38	78.62	78.50	78.81	78.88	78.94	40.19	72.00	40.19
84	88.88	90.38	90.62	90.50	90.81	90.88	90.94	46.19	84.00	46.19
96	100.88	102.38	102.62	102.50	102.81	102.88	102.94	52.19	96.00	52.19
108	112.88	114.38	114.62	114.50	114.81	114.88	114.94	58.19	108.00	58.19
120	124.88	126.38	126.62	126.50	126.81	126.88	126.94	64.19	120.00	64.19

Table 7. Fisher 249B and 249BF Dimension A

A (COMMON DIMENSION)													
Scrd NPT		CL150 RF		CL150 RTJ		CL300 RF		CL300 RTJ		CL600 RF		CL600 RTJ	
mm	Inch	mm	Inch	mm	Inch	mm	Inch	mm	Inch	mm	Inch	mm	Inch
121	4.75	145	5.69	151	5.94	148	5.81	155	6.12	157	6.19	159	6.25

Table 8. Fisher 249B and 249BF Dimensions W and G

COMMON DIMENSION					
Displacer Length		W		G	
mm	Inch	mm	Inch	mm	Inch
356	14	394	15.50	197	7.75
813	32	851	33.50	425	16.75
1219	48	1257	49.50	629	24.75
1524	60	1562	61.50	781	30.75
1829	72	1867	73.50	933	36.75
2134	84	2172	85.50	1086	42.75
2438	96	2477	97.50	1238	48.75
2743	108	2781	109.50	1391	54.75
3048	120	3086	121.50	1543	60.75

249C and 249K (NPS 1-1/2 & 2 End Connections)

Figure 4. Fisher 249C and 249K (see tables 9, 10, and 11)

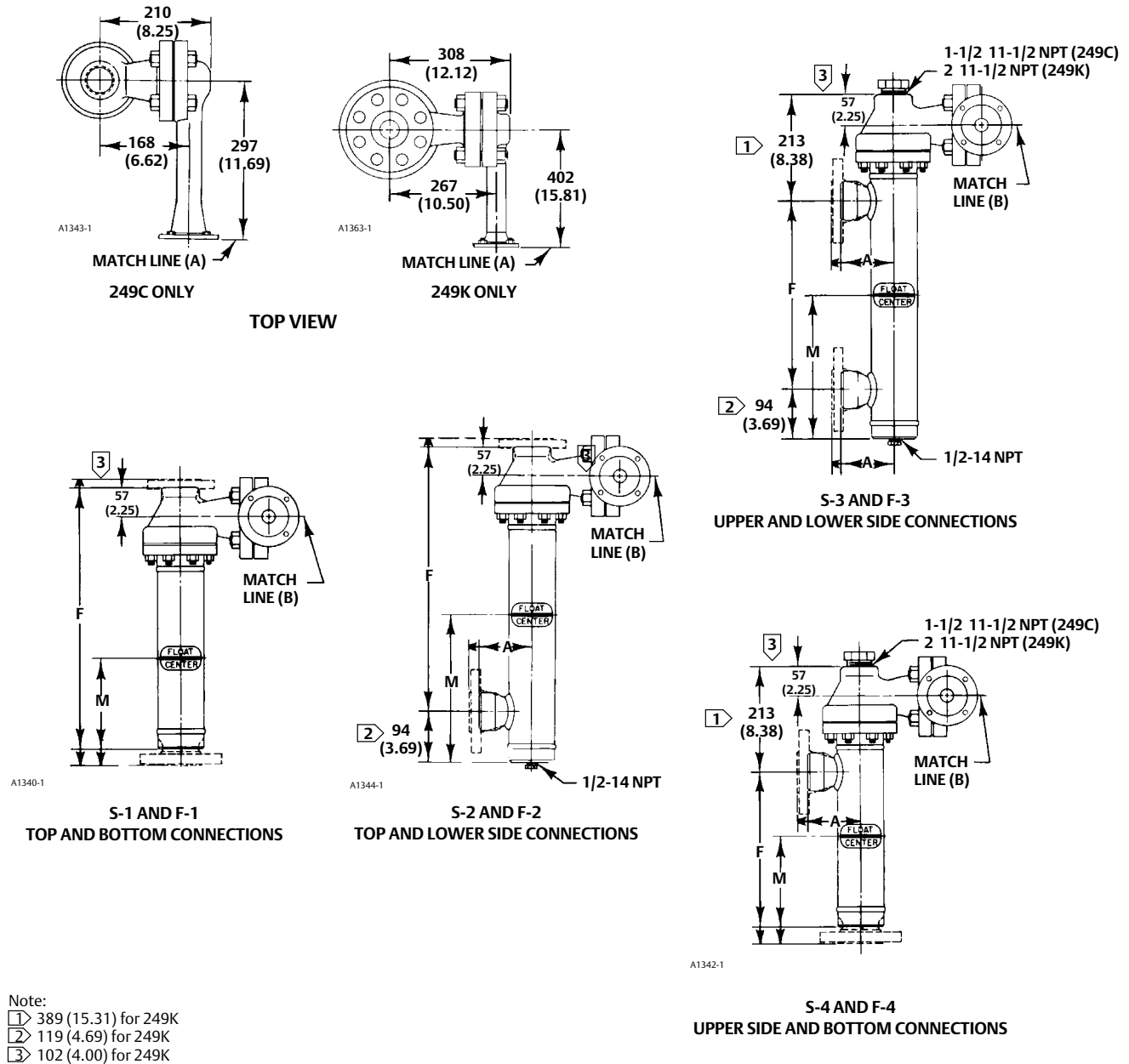

Table 9. Fisher 249C and 249K Dimensions F and M, S-1, F-1, S-4, and F-4 Connections

Conn. Style	Dis-placer Length	249C														249K				
		F								M								F		M
		Scrd NPT	CL150		CL300		CL600		Scrd NPT	CL150		CL300		CL600		NPS 1-1/2 Flg.	NPS 2 Flg.	Flg.		
RF	RTJ		RF	RTJ	RF	RTJ	RF	RTJ		RF	RTJ	RF	RTJ							
S-1 and F-1 (mm)	356	489	530	543	546	559	560	560	235	257	264	264	270	272	272	645	654	305		
	813	946	988	1000	1003	1016	1018	1018	464	486	492	492	498	500	500	1102	1111	533		
	1219	1353	1394	1407	1410	1422	1424	1424	667	689	695	695	702	703	703	---	---	---		
	1524	1357	1699	1711	1715	1727	1729	1729	819	841	848	848	854	856	856	---	---	---		
	1829	1962	2004	2016	2019	2032	2034	2034	972	994	1000	1000	1006	1008	1008	---	---	---		
	2134	---	2308	---	2324	2337	---	---	---	1146	---	1153	1159	---	---	---	---	---		
2438	2826	2613	---	2781	---	---	---	127	1298	---	1305	---	---	---	---	---	---			
S-1 and F-1 (In.)	14	19.25	20.88	21.38	21.50	22.00	22.06	22.06	9.25	10.12	10.38	10.38	10.62	10.69	10.69	25.38	25.75	12.00		
	32	37.25	38.88	39.38	39.50	40.00	40.06	40.06	18.25	19.12	19.38	19.38	19.62	19.69	19.69	43.38	43.75	21.00		
	48	53.25	54.88	55.38	55.50	56.00	56.06	56.06	26.25	27.12	27.38	27.38	27.62	27.69	27.69	---	---	---		
	60	65.25	66.88	67.38	67.50	68.00	68.06	68.06	32.25	33.12	33.38	33.38	33.62	33.69	33.69	---	---	---		
	72	77.25	78.88	79.38	79.50	80.00	80.06	80.06	38.25	39.12	39.38	39.38	39.62	39.69	39.69	---	---	---		
	84	---	90.88	---	91.50	92.00	---	---	---	45.12	---	45.38	45.62	---	---	---	---	---		
96	111.25	102.88	---	109.50	---	---	---	50.25	51.12	---	51.38	---	---	---	---	---	---			
S-4 and F-4 (mm)	356	409	432	438	438	445	446	446	232	254	260	260	267	268	268	483	483	305		
	813	867	889	895	895	902	903	903	460	483	489	489	495	497	497	940	940	533		
	1219	1273	1295	1302	1302	1308	1310	1310	667	686	692	692	699	700	700	---	---	---		
	1524	1518	1600	1607	1607	1613	1614	1614	816	838	845	845	851	852	852	---	---	---		
	1829	1883	1905	1911	1911	1918	1919	1919	968	991	997	997	1003	1005	1005	---	---	---		
	2134	---	2210	---	---	---	---	---	---	1143	---	---	---	---	---	---	---	---		
2438	---	2515	---	---	---	---	---	---	1295	---	---	---	---	---	---	---	---			
S-4 and F-4 (In.)	14	16.12	17.00	17.25	17.25	17.50	17.56	17.56	9.12	10.00	10.25	10.25	10.50	10.56	10.56	19.00	19.00	12.00		
	32	34.12	35.00	35.25	35.25	35.50	35.56	35.56	18.12	19.00	19.25	19.25	19.50	19.56	19.56	37.00	37.00	21.00		
	48	50.12	51.00	51.25	51.25	51.50	51.56	51.56	26.12	27.00	27.25	27.25	27.50	27.56	27.56	---	---	---		
	60	62.12	63.00	63.25	63.25	63.50	63.56	63.56	32.12	33.00	33.25	33.25	33.50	33.56	33.56	---	---	---		
	72	74.12	75.00	75.25	75.25	75.50	75.56	75.56	38.12	39.00	39.25	39.25	39.50	39.56	39.56	---	---	---		
	84	---	87.00	---	---	---	---	---	---	45.00	---	---	---	---	---	---	---	---		
96	---	99.00	---	---	---	---	---	---	51.00	---	---	---	---	---	---	---	---			

Table 10. Fisher 249C and 249K, Dimensions F and M, S-2, F-2, S-3, and F-3 Connections

Dis-placer Length	S-2 AND F-2 CONNECTIONS										S-3 AND F-3 CONNECTIONS					
	249C								249K				249C		249K	
	Scrd NPT	F						M	F		M	F	M	F	M	
CL150		CL300		CL600		NPS 1-1/2 Flg.	NPS 2 Flg.									
mm																
356	432	451	457	460	467	467	467	272	518	527	297	356	272	356	297	
813	889	908	914	917	924	924	924	500	975	984	526	813	500	813	526	
1219	1295	1314	1321	1324	1330	1330	1330	703	---	---	---	1219	703	---	---	
1524	1600	1619	1626	1629	1635	1635	1635	856	---	---	---	1524	856	---	---	
1829	1905	1924	1930	1933	1940	1940	1940	1008	---	---	---	1829	1008	---	---	
2134	---	2229	---	2238	---	---	---	1161	---	---	---	2134	1161	---	---	
2438	---	---	---	---	---	---	---	---	---	---	---	2438	1313	---	---	
Inches																
14	17.00	17.75	18.00	18.12	18.38	18.38	18.38	10.69	20.38	20.75	11.69	14.00	10.69	14.00	11.69	
32	35.00	35.75	36.00	36.12	36.38	36.38	36.38	19.69	38.38	38.75	20.69	32.00	19.69	32.00	20.69	
48	51.00	51.75	52.00	52.12	52.38	52.38	52.38	27.69	---	---	---	48.00	27.69	---	---	
60	63.00	63.75	64.00	64.12	64.38	64.38	64.38	33.69	---	---	---	60.00	33.69	---	---	
72	75.00	75.75	76.00	76.12	76.38	76.38	76.38	39.69	---	---	---	72.00	39.69	---	---	
84	---	87.75	---	88.12	---	---	---	45.69	---	---	---	84.00	45.69	---	---	
96	---	---	---	---	---	---	---	---	---	---	---	96.00	51.69	---	---	

Table 11. Fisher 249C and 249K Dimension A

END CONNECTION SIZE		249C SCREWED		249C CL150 RF		249C CL150 RTJ CL300 RF		249C CL300 RTJ		249C CL600 RF or RTJ		249K CL1500 FLANGES	
DN	NPS	mm	Inch	mm	Inch	mm	Inch	mm	Inch	mm	Inch	mm	Inch
40	1-1/2	102	4.00	111	4.38	117	4.62	122	4.81	125	4.94	148	5.81
50	2	102	4.00	111	4.38	117	4.62	125	4.94	125	4.94	168	6.62

249L

Figure 5. Fisher 249L

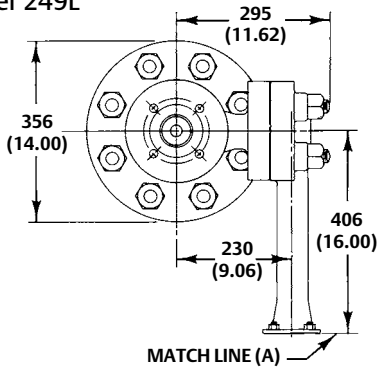

A1346-1

TOP VIEW

DISPLACER LENGTH	DIMENSION F			
	F-1(1)	F-2(1)	F-3(1)	F-4(1)
mm				
356	783	629	356	510
813	1240	1086	813	967
INCHES				
14	30.81	24.75	14.00	20.06
32	48.81	42.75	32.00	38.06

1. 249L Sensor has CL2500 RTJ flanges.

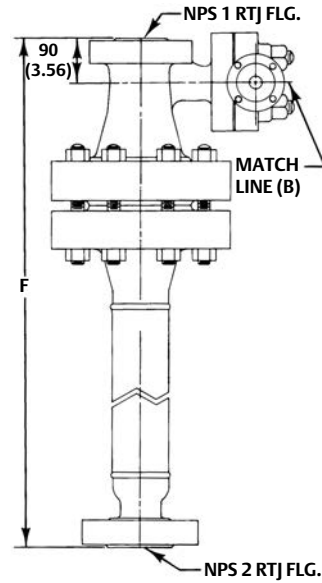

A1347-1

F1
TOP AND BOTTOM CONNECTIONS

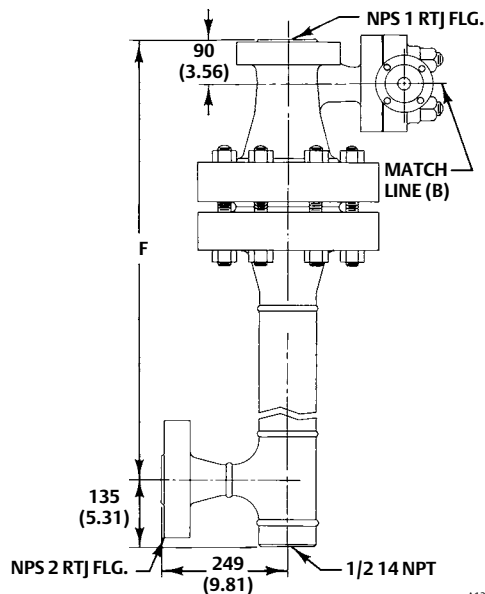

A1349-1

F2
TOP AND LOWER SIDE CONNECTIONS

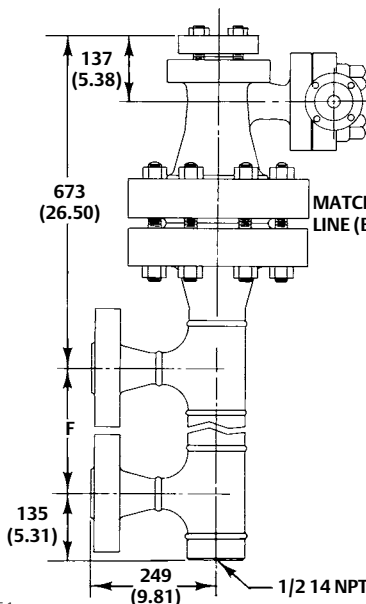

A1345-1

F3
UPPER AND LOWER SIDE CONNECTION
(NPS 2 RTJ FLG.)

SIDE VIEW

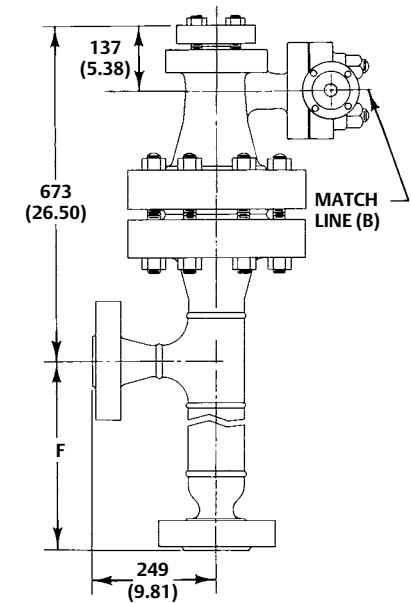

A1348-1

F4
UPPER SIDE AND BOTTOM CONNECTIONS
(NPS 2 RTJ FLG.)

mm
(INCH)

249BP and 249P

Figure 6. Fisher 249BP and 249P (see tables 12 and 13)

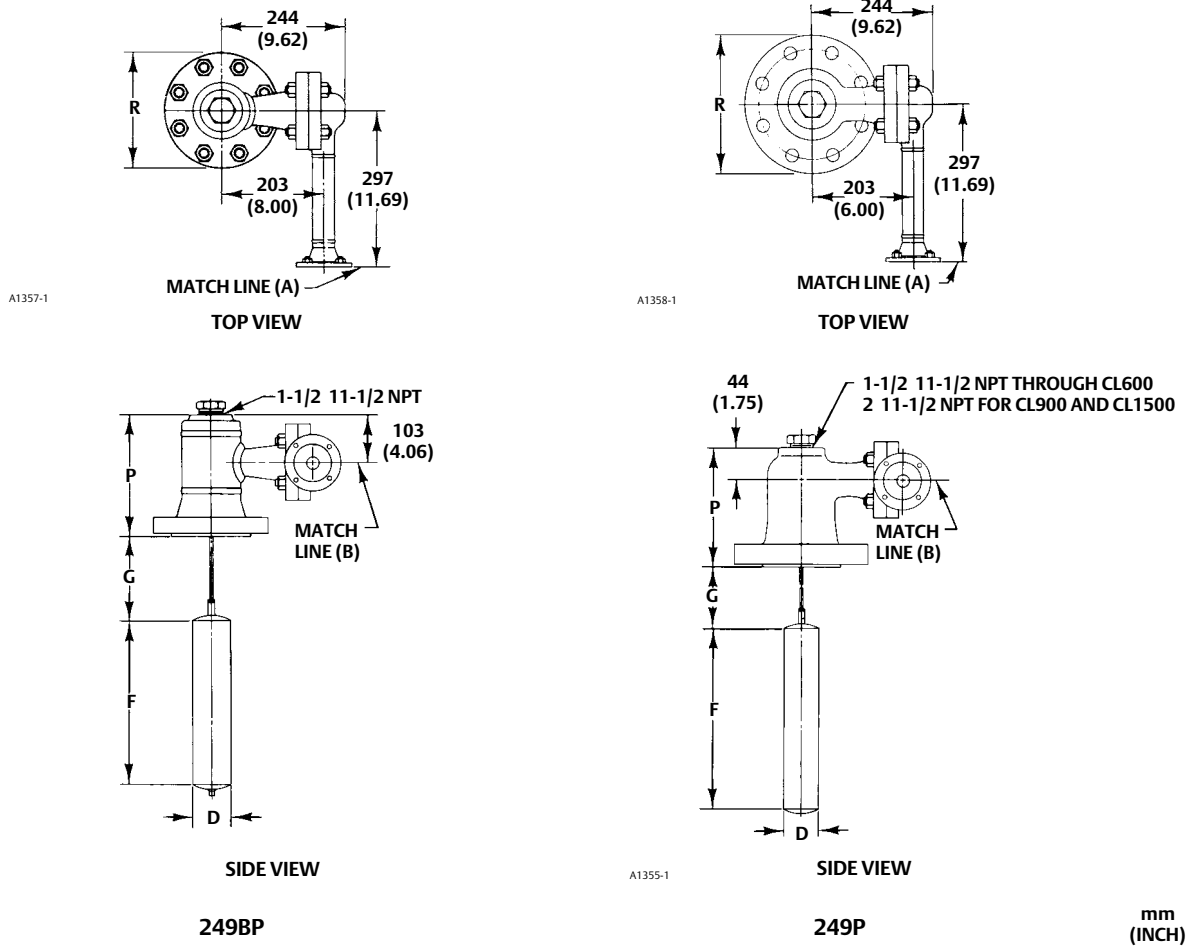

mm
(INCH)

Table 12. Fisher 249BP and 249P Dimension D, F, and G

STANDARD DISPLACER AND STEM COMBINATIONS				
D		F		G ⁽¹⁾
mm	Inch	mm	Inch	
76	3.00	356	14.00	Specify. Maximum length is 1372 mm (54 inch)
51	2.00	813	32.00	
41	1.62	1219	48.00	
38	1.50	1524	60.00	
35	1.38	1829	72.00	
32	1.25	2134	84.00	
29	1.12	2438	96.00	
25	1.00	2743	108.00	
25	1.00	3048	120.00	

1. If not specified, G dimension will be 305 mm (12 inches).

Table 13. Fisher 249BP and 249P Dimension P and R

DIMENSION	TYPE NO.	FLANGE SIZE, NPS	CL125 FF	CL250 RF	CL150		CL300		CL600		CL900		CL1500	
					RF	RTJ	RF	RTJ	RF	RTJ	RF	RTJ	RF	RTJ
mm														
P	249BP	4	---	---	238	244	256	270	272	---	---	---	---	---
		6	---	---	240	---	---	---	---	---	---	---	---	---
		8	---	---	243	---	---	---	---	---	---	---	---	---
R		4	---	---	229	229	254	254	273	273	---	---	---	---
		6	---	---	279	---	318	---	---	---	---	---	---	---
		8	---	---	343	---	381	---	---	---	---	---	---	---
P	249P	4	214	222	214	221	222	230	---	236	303	305	313	314
		6	216	227	216	---	227	---	244	---	---	---	---	---
		8	219	232	219	---	232	---	---	---	---	---	---	---
R		4	229	254	229	---	254	254	---	273	292	292	311	311
		6	279	318	279	---	318	---	356	---	---	---	---	---
		8	343	381	343	---	381	---	---	---	---	---	---	---
Inches														
P	249BP	4	---	---	9.38	9.62	9.74	10.06	10.62	10.69	---	---	---	---
		6	---	---	9.44	---	9.94	---	---	---	---	---	---	---
		8	---	---	9.56	---	10.12	---	---	---	---	---	---	---
R		4	---	---	9.00	9.00	10.00	10.00	10.75	10.75	---	---	---	---
		6	---	---	11.00	---	12.50	---	---	---	---	---	---	---
		8	---	---	13.50	---	15.00	---	---	---	---	---	---	---
P	249P	4	8.44	8.75	8.44	8.69	8.75	9.06	---	9.31	11.94	12.00	12.31	12.38
		6	8.50	8.94	8.50	---	8.94	---	9.62	---	---	---	---	---
		8	8.62	9.12	8.62	---	9.12	---	---	---	---	---	---	---
R		4	9.00	10.00	9.00	9.00	10.00	10.00	---	10.75	11.50	11.50	12.25	12.25
		6	11.00	12.50	11.00	---	12.50	---	14.00	---	---	---	---	---
		8	13.50	15.00	13.50	---	15.00	---	---	---	---	---	---	---

249CP (NPS 3 RF Flanged)

Figure 7. Fisher 249CP (see tables 14 and 15)

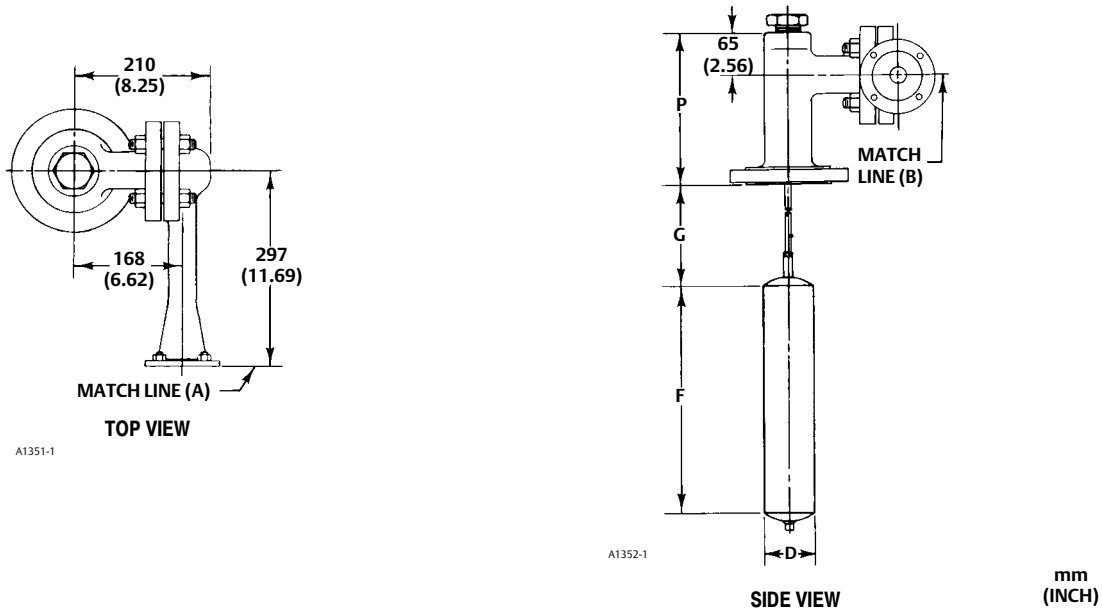

Table 14. Fisher 249CP Dimensions D, F, and G

STANDARD DISPLACER AND STEM COMBINATIONS				
D		F		G ⁽¹⁾
mm	Inch	mm	Inch	
60	2.38	356	14.00	Specify. Maximum length is 1372 mm (54 inches)
38	1.50	813	32.00	
32	1.25	1219	48.00	

1. If not specified, G dimension will be 305 mm (12 inches).

Table 15. Fisher 249CP Dimension P

P					
CL150 RF		CL300 RF		CL600 RF	
mm	Inch	mm	Inch	mm	Inch
191	7.50	200	7.88	210	8.25

249VS

Figure 8. Fisher 249VS with DLC3010 / DLC3020f Digital Level Controller Controller Envelope Dimensions; Flanged Connections

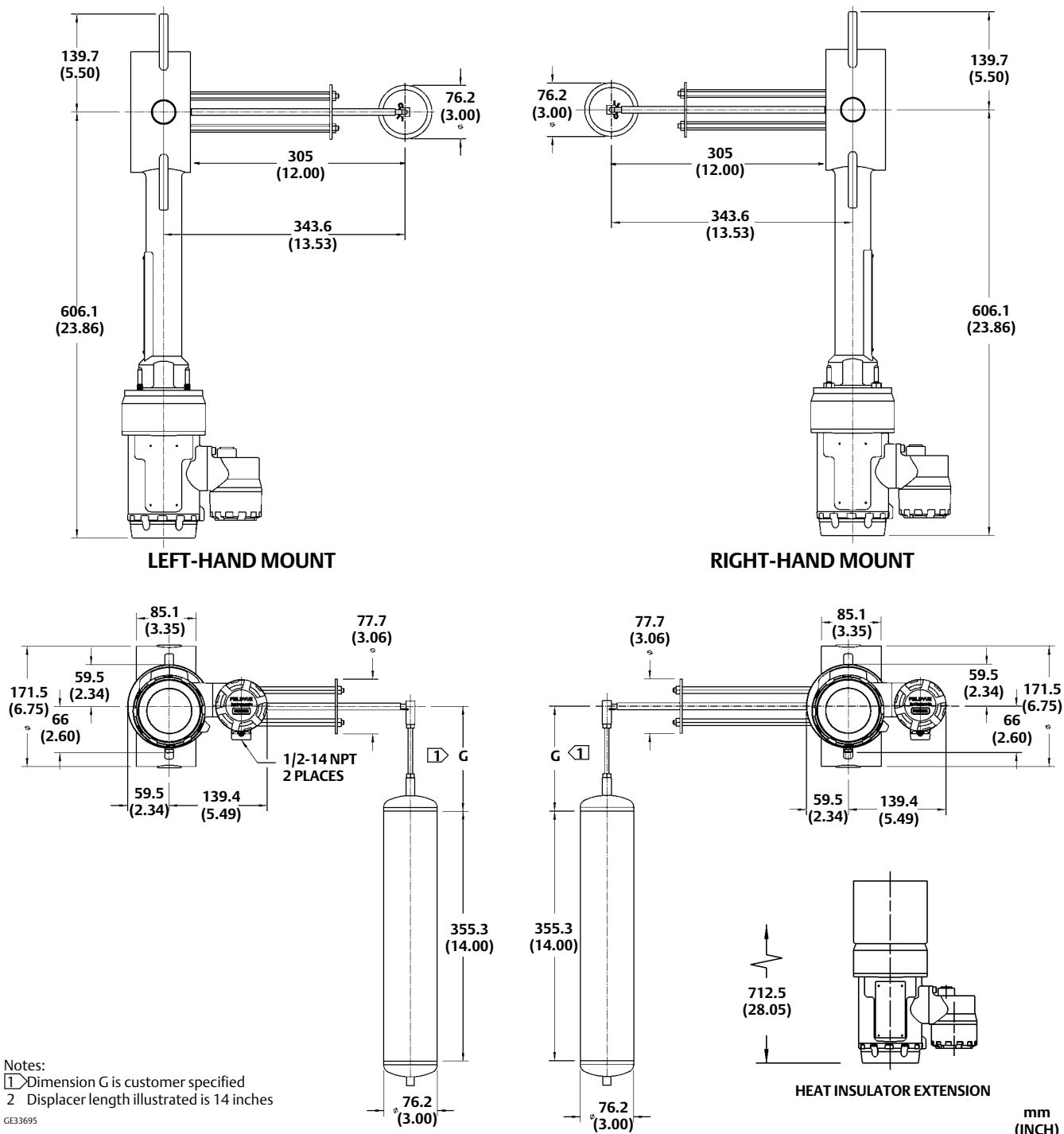

Notes:
 1 Dimension G is customer specified
 2 Displacer length illustrated is 14 inches
 GE33695

Figure 9. Fisher 249VS with DLC3010 / DLC3020f Digital Level Controller Envelope Dimensions; Butt Weld End

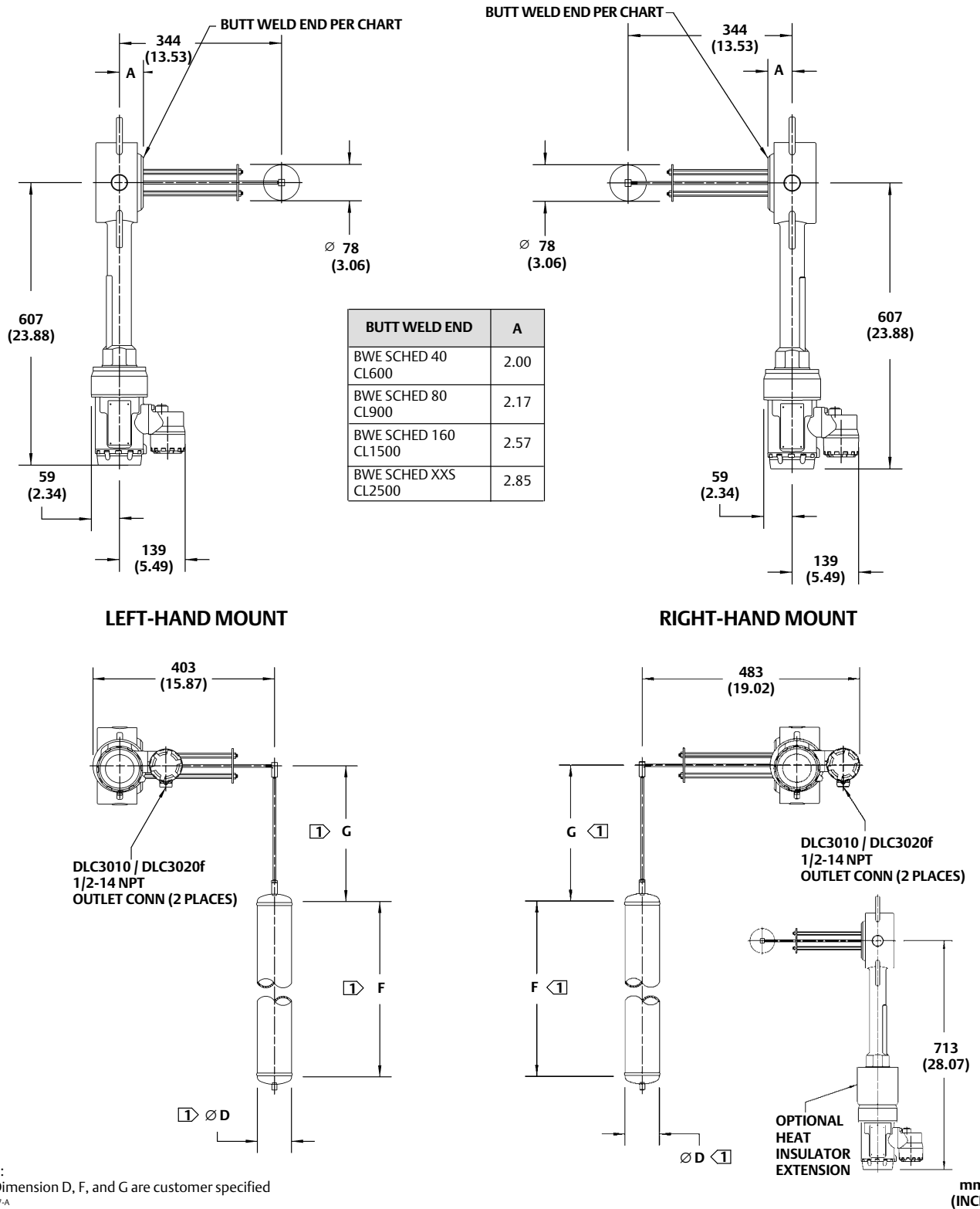
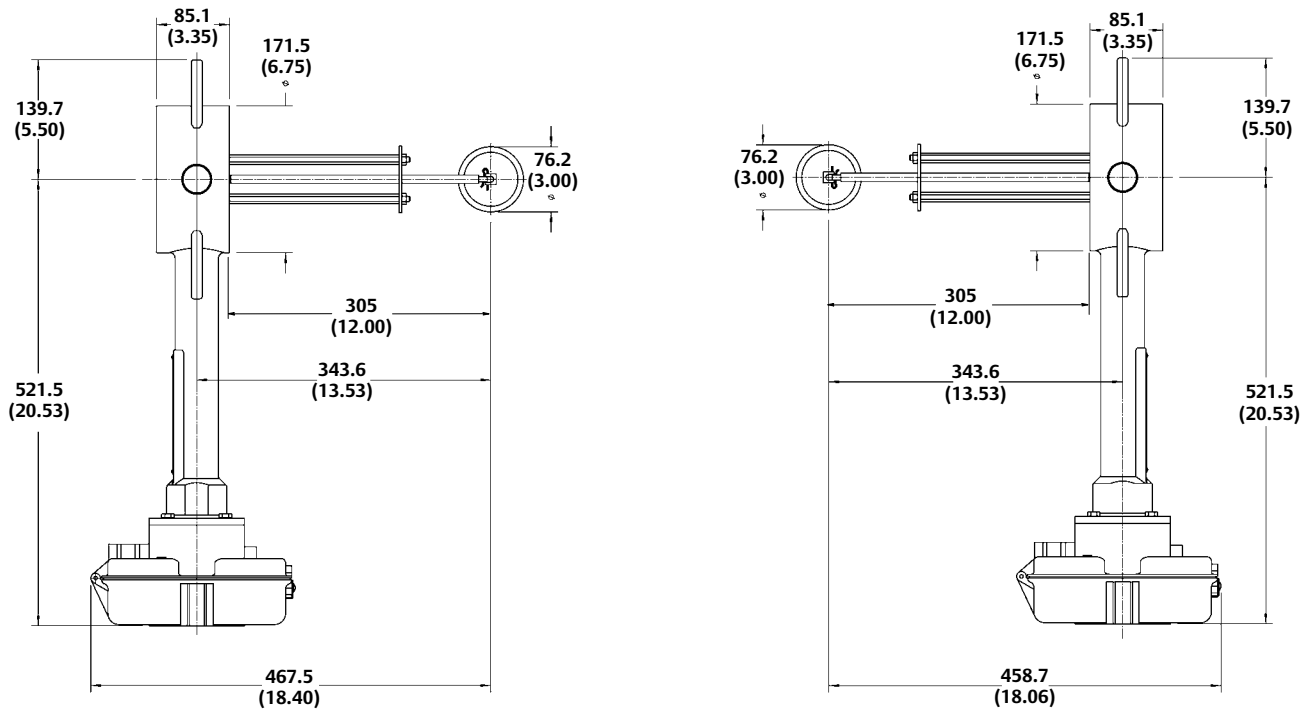
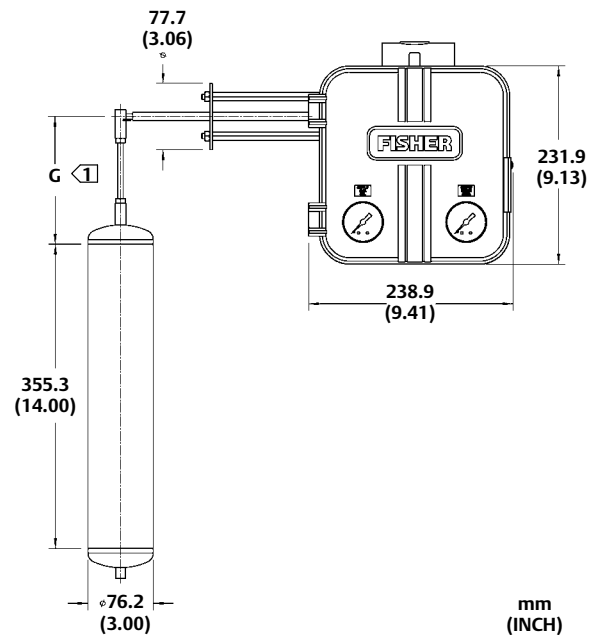
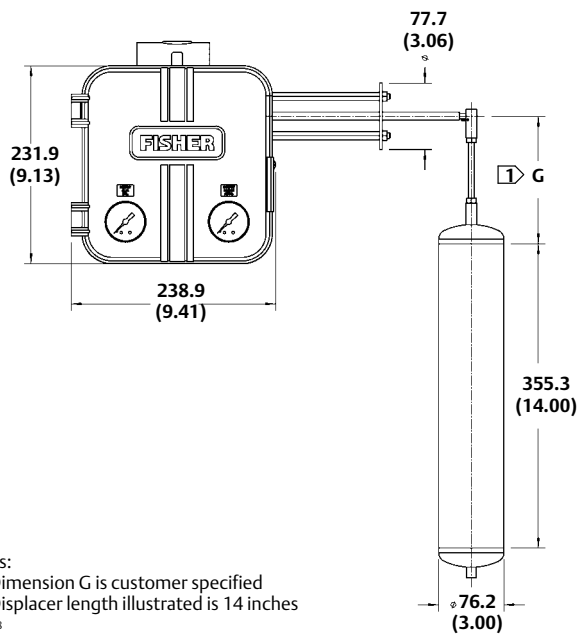

Figure 10. Fisher 249VS with 2500 Transmitter Envelope Dimensions; Flanged Connections



LEFT-HAND MOUNT

RIGHT-HAND MOUNT



Notes:
 1 Dimension G is customer specified
 2 Displacer length illustrated is 14 inches
 GE33808

mm
(INCH)

Figure 11. Fisher 249VS with 2500 Transmitter Envelope Dimensions; Butt Weld End

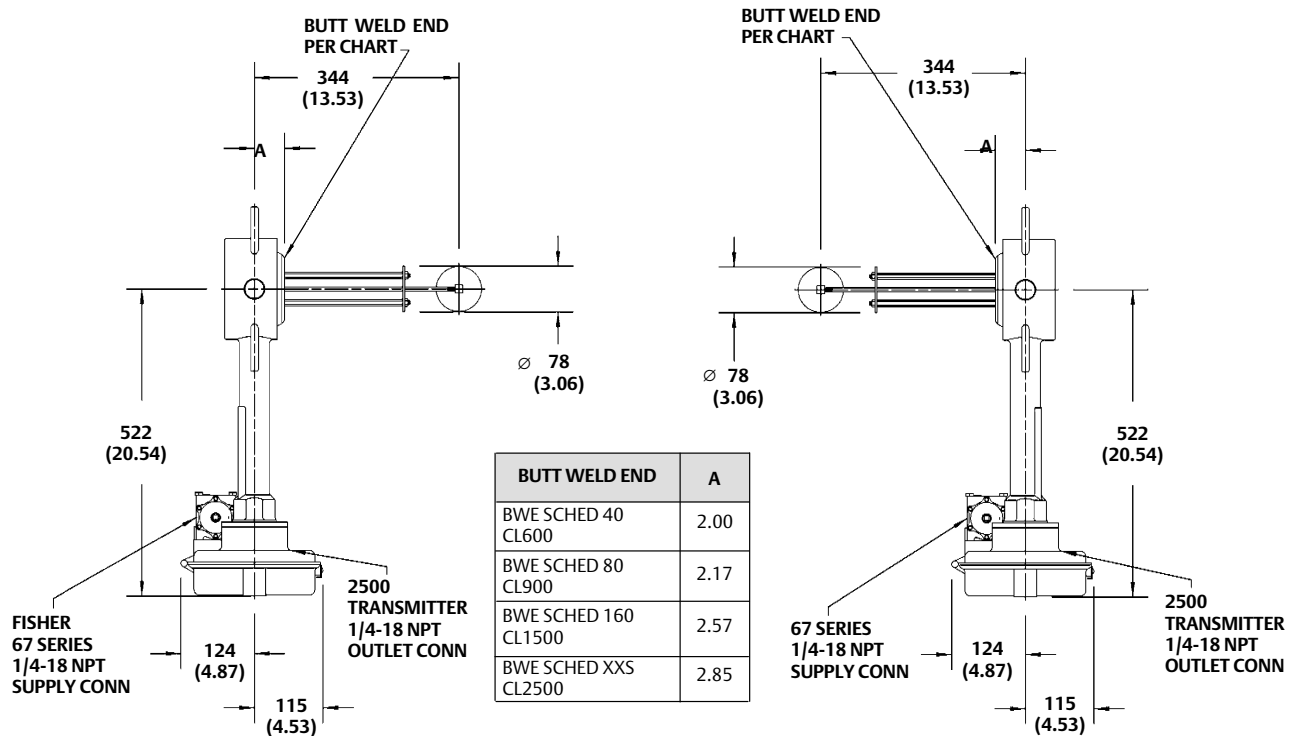

LEFT-HAND MOUNT

RIGHT-HAND MOUNT

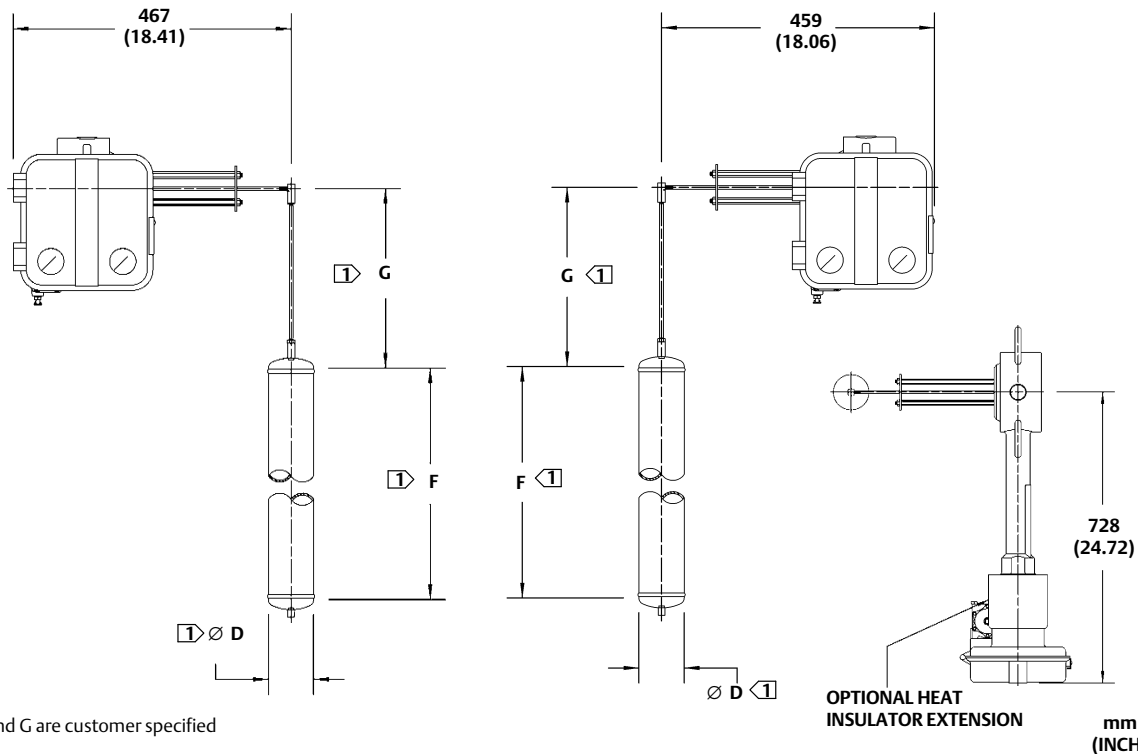

Notes:
 [1] Dimension D, F, and G are customer specified
 GE45166-A

249W

Figure 12. Fisher 249W Dimensions for Mounting on Customer Supplied Cage

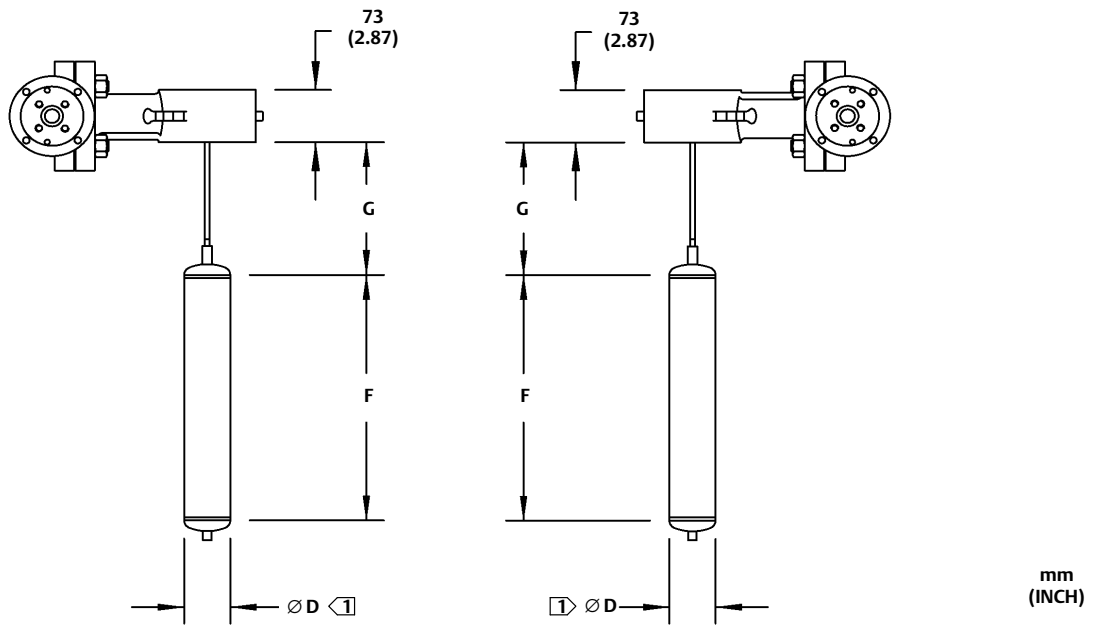
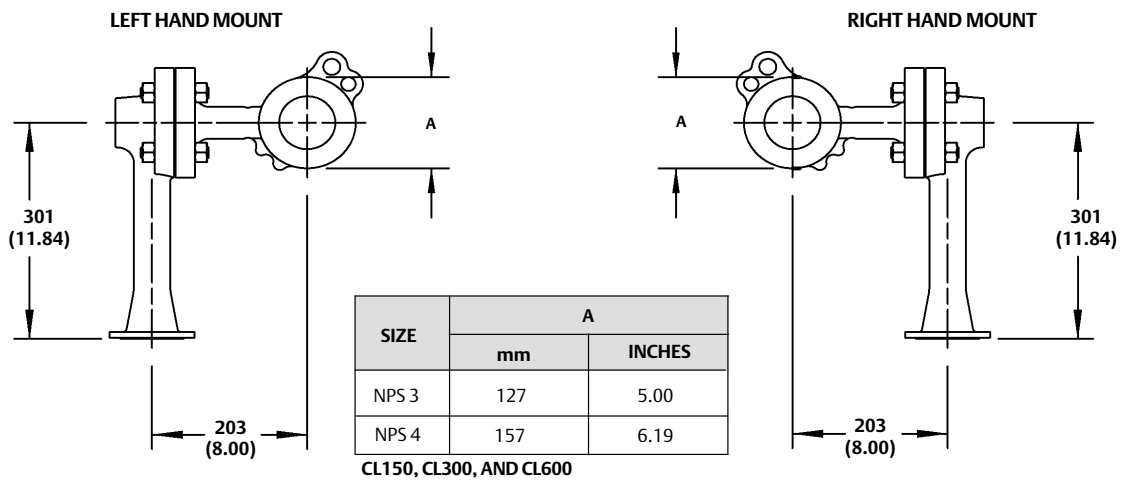

Note:
 $\varnothing D$ Dimensions D, F, and G are customer defined
 GE09610-A

Controllers and Transmitters

Figure 13. Controller and Transmitter Dimensions; Fisher 2500 Controller / Transmitter

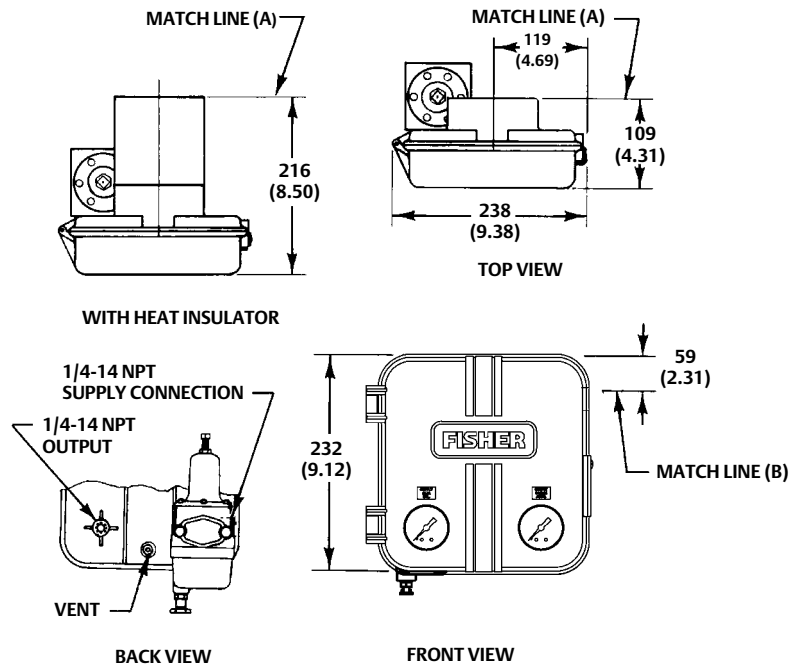

10A1211-A
22A9197-B
A1373-1

2500 CONTROLLER / TRANSMITTER

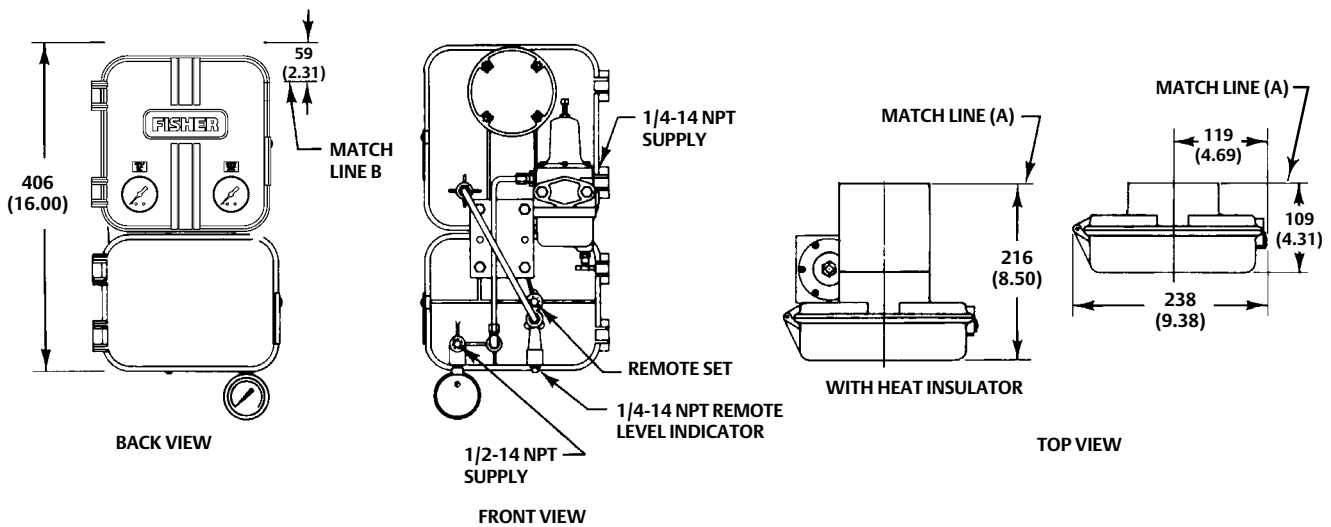

2500 CONTROLLER / TRANSMITTER
WITH 2506 OR 2516 RECEIVER-CONTROLLER

mm
(INCH)

AR5748-B
22A9197-B
A1374-1

Figure 14. Controller and Transmitter Dimensions; FIELDVUE DLC3010 / DLC3020f Digital Level Controller

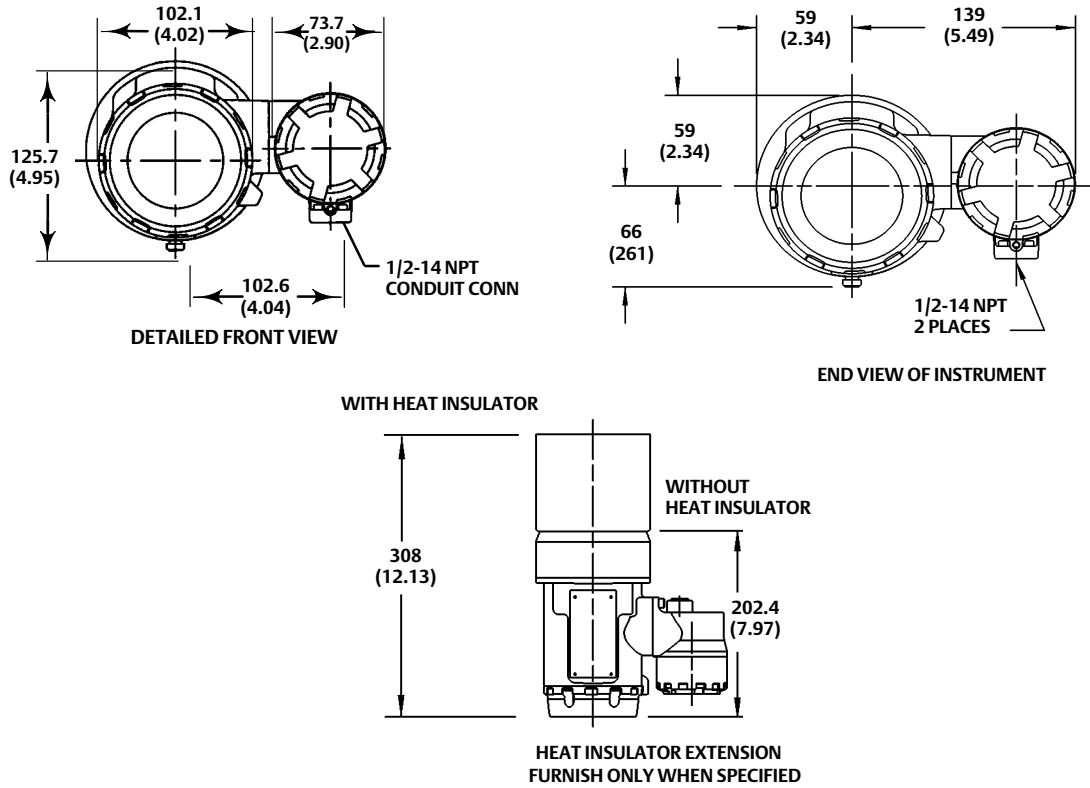

mm
(INCH)

Neither Emerson, Emerson Process Management, nor any of their affiliated entities assumes responsibility for the selection, use or maintenance of any product. Responsibility for proper selection, use, and maintenance of any product remains solely with the purchaser and end user.

Fisher and FIELDVUE are marks owned by one of the companies in the Emerson Process Management business unit of Emerson Electric Co. Emerson Process Management, Emerson, and the Emerson logo are trademarks and service marks of Emerson Electric Co. All other marks are the property of their respective owners.

The contents of this publication are presented for informational purposes only, and while every effort has been made to ensure their accuracy, they are not to be construed as warranties or guarantees, express or implied, regarding the products or services described herein or their use or applicability. All sales are governed by our terms and conditions, which are available upon request. We reserve the right to modify or improve the designs or specifications of such products at any time without notice.

Emerson Process Management
Marshalltown, Iowa 50158 USA
Sorocaba, 18087 Brazil
Chatham, Kent ME4 4QZ UK
Dubai, United Arab Emirates
Singapore 128461 Singapore

www.Fisher.com