

Fisher® 4195KA, KB, KC, and KS Gauge Pressure Controllers

Contents

1. Introduction	
Scope of Manual	4
Description	4
Specifications	4
Educational Services	4
2. Installation	
Controller Mounting Orientation	9
Pipestand Mounting	9
Panel Mounting	10
Wall Mounting	11
Actuator Mounting	11
Pressure Connections	12
Process Pressure Connection	12
Supply Pressure Connection	12
Remote Set Point (suffix letter M)	
Pressure Connection	13
External Feedback Pressure Connection (4195KB Controllers Only)	13
Vent	14
3. 4195KA Proportional-Only Controllers	
Adjustments for 4195KA Controllers	15
Manual Set Point Adjustment	15
Remote Set Point (suffix letter M)	
Adjustment	16
Proportional Band Adjustment (PB ADJ)	16
Changing Controller Action	16
Switching The Auto/Manual Station (suffix letter E)	17
Prestartup Checks for 4195KA Controllers	17
Startup for 4195KA Controllers	18
Calibration of 4195KA Controllers	18
General Calibration Instructions	19
Process Indicator Zero and Span Calibration	19
Remote Set Point (suffix letter M)	
Zero and Span Calibration	21
Flapper Alignment	22
Principle of Operation for 4195KA Controllers	23
Overall Operation	23
Remote Set Point (suffix letter M)	
Operation	24
Auto/Manual Station (suffix letter E)	
Operation	24
4. 4195KB Proportional-Plus-Reset Controllers and 4195KC Proportional-Plus-Reset-Plus-Rate Controllers	
Adjustments for 4195KB and KC Controllers	25
Manual Set Point Adjustment	25
Remote Set Point (suffix letter M)	
Adjustment	26
Proportional Band Adjustment (PB ADJ)	26
Changing Controller Action	26
Reset Adjustment	27
Rate Adjustment	27
Anti-Reset Windup (suffix letter F)	
Adjustment	27
Switching the Auto/Manual Station (suffix letter E)	27
Prestartup Checks for 4195KB and KC Controllers	28
Startup for 4195KB and KC Controllers	28
Calibration of 4195KB and KC Controllers	30
General Calibration Instructions	30
Process Indicator Zero and Span Calibration	30
Remote Set Point (suffix letter M)	
Zero and Span Calibration	32
Flapper Alignment	33
Anti-Reset Windup (suffix letter F)	
Differential Relief Valve Calibration	35
Principle of Operation for 4195KB and KC Controllers	36
Overall Operation	36
Anti-Reset Windup (suffix letter F)	
Operation	39
Remote Set Point (suffix letter M)	
Operation	39
Auto/Manual Station (suffix letter E)	
Operation	40
External Feedback Operation	41
5. 4195KS Differential Gap Controllers	
Operating Information	42
Adjustments for 4195KS Differential Gap Controllers	43
Manual Set Point	43
Remote Set Point (Option M)	43
Proportional Band (Differential Gap)	43
Changing Controller Action	43



Contents (continued)

Auto/Manual Switching (Option E)	44	Capsular Element Controller Maintenance and Calibration	82
Prestartup Checks	44	Replacing the Capsular Element Assembly	82
Startup	44	Replacing Capsular Element Parts	83
Calibration	45	Replacing the Long Pivot Assembly	83
Process Zero and Span Adjustment	45	Replacing the Short Pivot Assembly	84
Remote Set Point Zero and Span (Option M)	45	Replacing the Process Drive Flexure	84
Setting Switching Points	46	Replacing the Process Tubing	85
Direct-Acting Controllers	46	Replacing Capsular Element Controller Links	85
Reverse-Acting Controllers	48	Replacing Link 1	86
Principle of Operation	48	Replacing Link 2	86
Overall Operation	48	Replacing Link 3	87
Remote Set Point (Option M)	50	Replacing Link 4	87
Auto/Manual Option	50	Replacing Link 5	88
6. Maintenance		Capsular Element Controller Maintenance Calibration	88
Inspection and Maintenance	51	Precalibration Procedure	89
Troubleshooting	51	Aligning the Drive Bracket Assembly	89
Replacing Common Controller Parts	55	Setting the Travel Stops	89
Replacing the Process Pressure Scale	55	Aligning the Linkage	90
Replacing the Relay	56	Capsular Element Controller Zero and Span Adjustment	91
Replacing the Case and Cover	56	Remote Set Point (suffix letter M) Maintenance	92
Replacing the Gauges	57	Replacing the Remote Set Point Assembly	92
Replacing the Supply Gauge, Proportional, Reset, Reset Valve and Positive Tubing Feedback Assemblies	58	Replacing Remote Set Point Assembly Parts	94
Replacing the Proportional Band Adjustment Knob, Nozzle Assembly, and Set Point Beam Assembly	58	Replacing Pivot Assembly A (key 114)	94
Replacing the Flapper Assembly and Flapper Flexure Pivot Assembly	63	Replacing Pivot Assembly B (key 115)	95
Replacing the Proportional or Reset Bellows	68	Replacing the Drive Flexure	95
Replacing the Reset Restriction Valve (4195KB Controllers)	70	Replacing the Remote Set Point Tubing ...	96
Replacing the Rate/Reset Valve Assembly (4195KC Controllers)	71	Replacing Link A	96
Replacing the Anti-Reset Windup (suffix letter F) Differential Relief Valve ...	72	Replacing Link B	96
Replacing the Anti-Reset Windup (suffix letter F) Relief Valve Tubing Assembly	72	Remote Set Point (suffix letter M) Maintenance Calibration	96
Bourdon Tube Controller Maintenance and Calibration	73	Precalibration Procedure	96
Replacing the Bourdon Tube	73	Aligning the Flexures	97
Replacing Bourdon Tube Controller Links ...	74	Setting the Travel Stops	97
Replacing Link 1	74	Aligning the Linkage	98
Replacing Link 2	75	Remote Set Point Zero and Span Adjustment	98
Replacing Link 3	76	Remote Set Point Linearity Adjustment	99
Replacing Link 4	77	Auto/Manual Station (suffix letter E) Maintenance	100
Bourdon Tube Travel Stop Installation and Adjustment	78	Replacing the Auto/Manual Station	100
Bourdon Tube Controller Calibration: Zero and Span Adjustment	79	Replacing the Switch Body Assembly, Lever O-Ring, Switch Body O-Ring, and Tubing Assembly	101
		Replacing the Loader Range Spring, Diaphragm Assembly, Ball Seat, Tubing, and Ball	102
		Replacing the Loader Valve Plug and Valve Plug Spring	103

Figure 1-1. Fisher 4195K Gauge Pressure Controllers

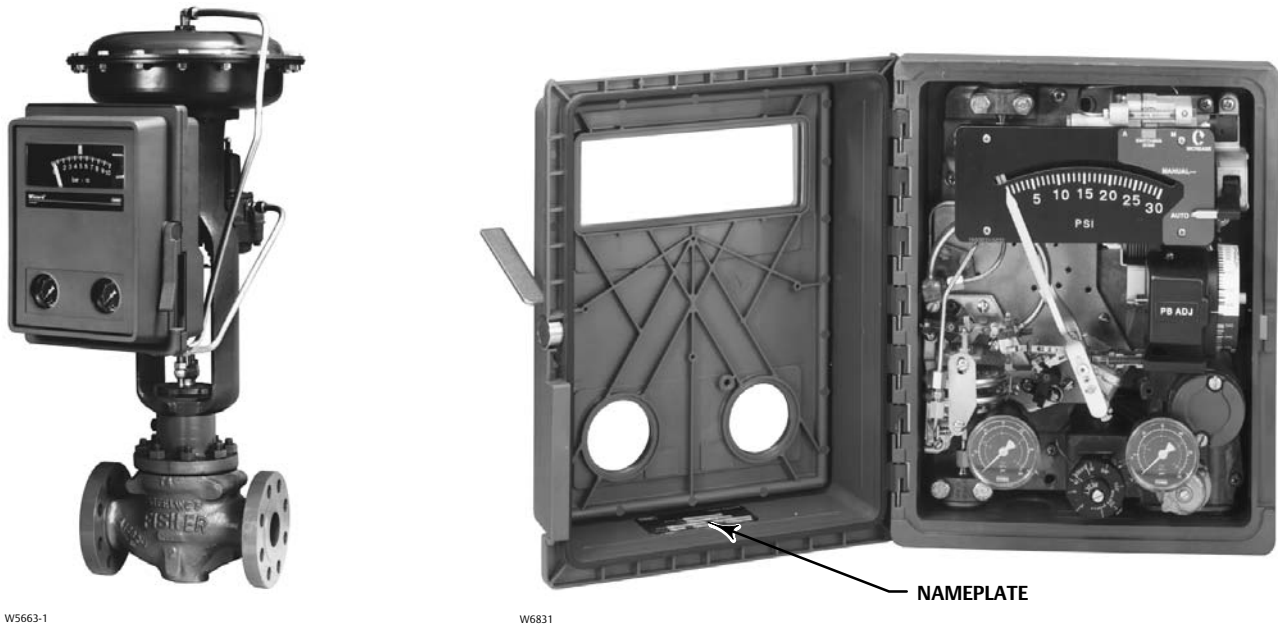

Contents (continued)

7. Parts

Parts Ordering	105	Panel Mounting	122
Parts Kits	105	Wall Mounting	122
Parts List	105	Controller Mounting Parts for Actuator with Casing-Mounted Controller	122
Abbreviations Used In The Parts List	105	Controller Mounting Parts for Actuator with Yoke-Mounted Controller	122
Controller Common Parts	106	Regulator Mounting Parts	123
Process and Set Point Indicator Assembly	114	Regulator Mounting Parts for Casing-Mounted Regulator	123
Indicator Assembly	116	Regulator Mounting Parts for Yoke-Mounted Regulator (Mounting Bracket Not Required)	123
Capsular Element Assembly	118	Regulator Mounting Parts for Yoke-Mounted Regulator (With Mounting Bracket)	123
Remote Set Point Assembly (suffix letter M)	119	Fittings	123
Auto/Manual Station (suffix letter E)	120		
Controller Mounting Parts	122		
Pipestand Mounting	122		
Pipestand Mounting with Regulator	122		

Section 1 Introduction

Scope of Manual

This instruction manual provides installation, operating, calibration, maintenance, and parts ordering information for Fisher 4195KA, KB, KC, and KS gauge pressure indicating controllers.

Portions of this manual apply only to specific 4195K controller configurations. These configurations are indicated by letter suffixes in the type number that correspond to the mode and option designated in table 1-2.

The specific controller type number (with letter suffixes) is located on the nameplate shown in figure 1-1. Refer to table 1-2 for the definition of each 4195K type number.

Do not install, operate, or maintain a 4195K controller without being fully trained and qualified in valve, actuator, and accessory installation, operation, and maintenance. **To avoid personal injury or property damage, it is important to carefully read, understand, and follow all the contents of this manual, including all safety cautions and warnings.** If you have any questions about these instructions, contact your Emerson Process Management sales office before proceeding.

Description

The controllers described in this manual provide gauge pressure control with the options as shown in table 1-2.

- 4195KA: Proportional-only control
- 4195KB: Proportional-plus-reset control
- 4195KC: Proportional-plus-reset-plus-rate control
- 4195KS: Differential gap control

These controllers show process pressure and set point on an easy-to-read process scale. The controller output is a pneumatic signal that operates a final control element.

Specifications

Specifications for 4195KA, KB, KC, and KS controllers are listed in table 1-1.

Educational Services

For information on available courses for 4195KA, 4195KB, 4195KC, and 4195KS gauge pressure indicating controllers, as well as a variety of other products, contact:

Emerson Process Management
Educational Services, Registration
P.O. Box 190; 301 S. 1st Ave.
Marshalltown, IA 50158-2823
Phone: 800-338-8158 or
Phone: 641-754-3771
FAX: 641-754-3431
e-mail: education@emerson.com

Table 1-1. Specifications

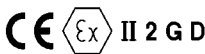
<p>Available Configurations See table 1-2</p> <p>Input Signal (Process Sensor Range) Lower and Upper Range Limits: See tables 1-3 and 1-4 Maximum Allowable Operating Limits: See tables 1-3 and 1-4</p> <p>Output Signal Proportional-Only, Proportional-Plus-Reset, or Proportional-Plus-Reset-Plus-Rate Range: 0.2 to 1.0 bar or 0.4 to 2.0 bar (3 to 15 psig or 6 to 30 psig) Differential Gap Range: 0 and 1.4 bar (0 and 20 psig) or 0 and 2.4 bar (0 and 35 psig) Action: Field-reversible between direct (increasing sensed process pressure increases output pressure) or reverse (increasing sensed process pressure decreases output pressure).</p> <p>Process Scale Standard scale is matched to the range of the sensing element, with the exception of receiver controllers. Optional⁽¹⁾ scales are available.</p> <p>Process Connections Standard: 1/4 NPT, internal, stainless steel (all input ranges) Optional: 1/2 NPT, see table 1-5</p> <p>Supply and Output Connections 1/4 NPT, internal</p> <p>Supply Pressure Requirements⁽²⁾ See table 1-6</p> <p>Supply Pressure Medium Air or natural gas Air: Supply pressure must be clean, dry air that meets the requirements of ISA Standard 7.0.01. A maximum 40 micrometer particle size in the air system is acceptable. Further filtration down to 5 micrometer particle size is recommended. Lubricant content is not to exceed 1 ppm weight (w/w) or volume (v/v) basis. Condensation in the air supply should be minimized. Natural Gas: Natural gas must be clean, dry, oil-free, and noncorrosive. H2S content should not exceed 20 ppm.</p>	<p>Remote Set Point Pressure Ranges 0.2 to 1.0 bar or 0.4 to 2.0 bar (3 to 15 psig or 6 to 30 psig)</p> <p>Controller Adjustments Proportional Band: 5 to 500% of process input span Reset: Adjustable from 0.01 to more than 74 minutes per repeat (from 100 to less than 0.0135 repeats per minute) Rate: Adjustable from 0 to 20 minutes Differential Gap Controllers: Adjustable from 5 to 100% of process scale range Set Point: Adjustable from 0 to 100% of the scale span</p> <p>Controller Performance Repeatability: 0.4% of output span Dead Band: Less than 0.4% of process scale span Typical Frequency Response: 1.5 hertz and 90 degree phase shift with 3.05 m (10 feet) of 6.4 mm (1/4-inch) tubing and 1639 cm³ (100 cubic inch) volume</p> <p>Steady-State Air Consumption⁽³⁾⁽⁴⁾ 0.2 to 1.0 Bar (3 to 15 Psig) Output: 0.1 normal m³/hr (3.5 scfh) 0.4 to 2.0 Bar (6 to 30 Psig) Output: 0.14 normal m³/hr (5.0 scfh)</p> <p>Delivery Capacity⁽³⁾ 0.2 to 1.0 Bar (3 to 15 Psig) Output: 5.9 normal m³/hr (240 scfh) 0.4 to 2.0 Bar (6 to 30 Psig) Output: 10.4 normal m³/hr (350 scfh)</p> <p>Operative Ambient Temperature Limits⁽²⁾⁽⁵⁾ -40 to 71 °C (-40 to 160 °F)</p> <p>Exhaust Capacity⁽³⁾ 0.2 to 1.0 Bar (3 to 15 Psig) Output: 4.6 normal m³/hr (186 scfh) 0.4 to 2.0 Bar (6 to 30 Psig) Output: 7.0 normal m³/hr (295 scfh)</p> <p>Hazardous Area Classification Complies with the requirements of ATEX Group II Category 2 Gas and Dust </p>
--	--

-continued-

Table 1-1. Specifications (continued)

<p>Housing Designed to NEMA 3 (Weatherproof) and IEC 529 IP54 Specifications</p> <p>Mounting Controller can be mounted on actuator, panel, wall, or pipestand.</p> <p>Approximate Weight 4.5 kg (10 pounds)</p>	<p>Declaration of SEP</p> <p>Fisher Controls International LLC declares this product to be in compliance with Article 3 paragraph 3 of the Pressure Equipment Directive (PED) 97 / 23 / EC. It was designed and manufactured in accordance with Sound Engineering Practice (SEP) and cannot bear the CE marking related to PED compliance.</p> <p>However, the product <i>may</i> bear the CE marking to indicate compliance with <i>other</i> applicable EC Directives.</p>
--	---

NOTE: Specialized instrument terms are defined in ANSI/ISA Standard 51.1 - Process Instrument Terminology.
 1. Consult your Emerson sales office for additional information.
 2. The pressure/temperature limits in this document and any applicable standard or code limitation should not be exceeded.
 3. Normal m³/hr—Normal cubic meters per hour (0°C and 1.01325 bar, absolute). Scfh—Standard cubic feet per hour (60°F and 14.7 psia).
 4. Without auto/manual station. With auto/manual station, air consumption is 0.28 normal m³/hr (10.0 Scfh) for either output range.
 5. Also use these temperatures for transportation and storage limits.

Table 1-2. Available Configurations for Fisher 4195KA, 4195KB, 4195KC, and 4195KS Controllers

CONTROLLER	TYPE NUMBER ⁽¹⁾	MODES				OPTIONS		
		Proportional-Only (One-Mode Controllers)	Proportional-Plus-Reset (Two-Mode Controllers)	Proportional-Plus-Reset-Plus-Rate (Three-Mode Controllers)	Differential Gap Controller	Internal Auto/Manual Station E	Anti-Reset Windup F	Remote Setpoint M
4195KA	4195KA	X	---	---	---	---	---	---
	4195KAE	X	---	---	---	X	---	---
	4195KAM	X	---	---	---	---	---	X
	4195KAME	X	---	---	---	X	---	X
4195KB	4195KB	---	X	---	---	---	---	---
	4195KBE	---	X	---	---	X	---	---
	4195KBF	---	X	---	---	---	X	---
	4195KBFE	---	X	---	---	X	X	---
	4195KBM	---	X	---	---	---	---	X
	4195KBME	---	X	---	---	X	---	X
	4195KBFM	---	X	---	---	---	X	X
4195KBFME	---	X	---	---	X	X	X	
4195KC	4195KC	---	---	X	---	---	---	---
	4195KCE	---	---	X	---	X	---	---
	4195KCF	---	---	X	---	---	X	---
	4195KCFE	---	---	X	---	X	X	---
	4195KCM	---	---	X	---	---	---	X
	4195KCM E	---	---	X	---	X	---	X
	4195KCFM	---	---	X	---	---	X	X
	4195KCFME	---	---	X	---	X	X	X
4195KS	4195KS	---	---	---	X	---	---	---
	4195KSE	---	---	---	X	X	---	---
	4195KSM	---	---	---	X	---	---	X
	4195KSME	---	---	---	X	X	---	X

1. Reverse-acting constructions are designated by the suffix letter R added to the type number.

Table 1-3. Process Sensor (Capsular Element) Pressure Ratings

CAPSULE MATERIAL	CAPSULAR STANDARD RANGES			SPAN ⁽¹⁾		OPERATING RANGE		OPERATING LIMIT ⁽²⁾
				Min	Max	Min	Max	
N09902	Metric units	Positive pressure	0 to 150 mbar	100 mbar	160 mbar	-350 mbar	350 mbar	510 mbar
			0 to 400 mbar	350 mbar	700 mbar	-1 bar	1 bar	1.5 bar
			0 to 0.6 bar	0.35 bar	0.7 bar	-1 bar	1 bar	1.5 bar
			0.2 to 1 bar	0.4 bar	0.8 bar	-1 bar	1.4 bar	2 bar
		0 to 1 bar	0.5 bar	1 bar	-1 bar	1.4 bar	2 bar	
		0 to 1.4 bar	0.7 bar	1.4 bar	-1 bar	1.7 bar	2.5 bar	
		0 to 1.6 bar	1 bar	2 bar	-1 bar	2.4 bar	3.5 bar	
		0.4 to 2 bar	0.8 bar	1.6 bar	-1 bar	2 bar	3 bar	
	0 to 2 bar	1 bar	2 bar	-1 bar	2.4 bar	3.5 bar		
	Vacuum	-150 to 0 mbar	85 mbar	170 mbar	-350 mbar	350 mbar	510 mbar	
		-340 to 0 mbar	170 mbar	340 mbar	-480 mbar	480 mbar	724 mbar	
		-400 to 0 mbar	350 mbar	700 mbar	-1 bar	1 bar	1.5 bar	
		-0.6 to 0 bar	0.35 bar	0.7 bar	-1 bar	1 bar	1.5 bar	
	-1 to 0 bar	0.5 bar	1 bar	-1 bar	1.4 bar	2 bar		
	Compound	-50 to 100 mbar	100 mbar	160 mbar	-350 mbar	350 mbar	510 mbar	
		-175 to 175 mbar	175 mbar	350 mbar	-480 mbar	480 mbar	724 mbar	
-150 to 250 mbar		350 mbar	700 mbar	-1 bar	1 bar	1.5 bar		
-0.2 to 0.4 bar		0.35 bar	0.7 bar	-1 bar	1 bar	1.5 bar		
-0.4 to 0.6 bar	0.5 bar	1 bar	-1 bar	1.4 bar	2 bar			
-0.6 to 0.8 bar	0.7 bar	1.4 bar	-1 bar	1.7 bar	2.5 bar			
-1 to 0.6 bar	1 bar	2 bar	-1 bar	2.4 bar	3.5 bar			
-1 to 1 bar	1 bar	2 bar	-1 bar	2.4 bar	3.5 bar			
U.S. units	Positive pressure	0 to 60 inch wc	40 inch wc	60 inch wc	-10 inch Hg	5 psig	7.5 psig	
		0 to 5 psig	2.5 psig	5 psig	-14 inch Hg	7 psig	10.5 psig	
		0 to 10 psig	5 psig	10 psig	-30 inch Hg	15 psig	22.5 psig	
		3 to 15 psig	6 psig	12 psig	-30 inch Hg	20 psig	30 psig	
	0 to 15 psig	7.5 psig	15 psig	-30 inch Hg	20 psig	30 psig		
	0 to 20 psig	10 psig	20 psig	-30 inch Hg	25 psig	37.5 psig		
	6 to 30 psig	12 psig	24 psig	-30 inch Hg	30 psig	45 psig		
	0 to 30 psig	15 psig	30 psig	-30 inch Hg	35 psig	52.5 psig		
	Vacuum	-5 to 0 inch Hg	2.5 inch Hg	5 inch Hg	-10 inch Hg	5 psig	7.5 psig	
		-10 to 0 inch Hg	5 inch Hg	10 inch Hg	-14 inch Hg	7 psig	10.5 psig	
		-20 to 0 inch Hg	10 inch Hg	20 inch Hg	-30 inch Hg	15 psig	22.5 psig	
		-30 to 0 inch Hg	15 inch Hg	30 inch Hg	-30 inch Hg	20 psig	30 psig	
Compound	-30 to 30 inch wc	40 inch wc	60 inch wc	-10 inch Hg	5 psig	7.5 psig		
	-5 inch Hg to 2.5 psig	2.5 psig	5 psig	-14 inch Hg	7 psig	10.5 psig		
	-10 inch Hg to 5 psig	5 psig	10 psig	-30 inch Hg	15 psig	22.5 psig		
	-15 inch Hg to 7.5 psig	7.5 psig	15 psig	-30 inch Hg	20 psig	30 psig		
-20 inch Hg to 10 psig	10 psig	20 psig	-30 inch Hg	25 psig	37.5 psig			
-30 inch Hg to 15 psig	15 psig	30 psig	-30 inch Hg	35 psig	52.5 psig			

1. Minimum or maximum span, or any span in between, may be positioned anywhere within the operating range. For example, if a 0 to 350 mbar (0 to 5 psig) sensing element is used and the minimum span of 1.75 mbar (2.5 psig) is set, the process indication can be calibrated to a range of -340 mbar to -203 mbar (-10 inch Hg to -6 inch Hg), 0 to 172 mbar (0 to 2.5 psig), 172 to 345 mbar (2.5 to 5 psig), 305 to 480 mbar (4.5 to 7 psig), or any value between minimum and maximum values of operating range.

2. Capsules with the travel stops set may be pressured to this value without permanent zero shift.

Table 1-4. Process Sensor (Bourdon Tube) Pressure Ratings and Materials

BOURDON TUBES		SPAN ⁽¹⁾		OPERATING RANGE ⁽²⁾		OPERATING LIMITS ⁽⁴⁾	STANDARD MATERIAL
		Minimum	Maximum	Minimum	Maximum ⁽³⁾		
Bar							
Metric units	0 to 1.6	1	2	-1	3	3.3	S31600 (316 SST)
	0 to 2.5	2	4	-1	6	6.6	
	0 to 4	2	4	-1	6	6.6	
	0 to 6	3.5	7	-1	10	11	
	0 to 10	7	14	-1	20	22	
	0 to 16	10	20	-1	30	33	
	0 to 25	20	40	0	60	66	
	0 to 40	20	40	0	60	66	
	0 to 60	55	70	0	90	103	
	0 to 100	76	100	0	135	155	
	0 to 160	160	200	0	270	310	
	0 to 300	250	350	0	420	482	
		Psig	Psig	Psig	Inch Hg	Psig	STANDARD MATERIAL
U.S. units	0 to 30	15	30	-30	42	48	S31600 (316 SST)
	0 to 60	30	60	-30	84	96	
	0 to 100	50	100	-30	140	160	
	0 to 200	100	200	-30	280	320	
	0 to 300	150	300	-30	420	480	
	0 to 600	300	600	0	840	960	
	0 to 1000	750	1000	0	1300	1500	
	0 to 1500	1100	1500	0	1950	2250	
	0 to 3000	2200	3000	0	3900	4500	
	0 to 5000	3700	5000	0	6000	7000	

1. Minimum or maximum span, or any span in between, may be positioned anywhere within the operating range. For example, if a 0 to 2 bar (0 to 30 psig) sensing element is used and the minimum span of 1 bar (15 psig) is set, the process indication can be calibrated to a range of -1 to 0 bar (-30 inch Hg to 0 psig), 0 to 1 bar (0 to 15 psig), 1 to 2 bar (15 to 30 psig), 2 to 3 bar (27 to 42 psig) or any value between the operating range minimum and maximum values.
 2. Travel stops should be used when the maximum or minimum process pressure will be 5% over or under the calibrated range. For example, a 0 to 2 bar (0 to 30 psig) sensing element is calibrated for 0.7 to 2 bar (10 to 30 psig), the desired range. The minimum expected pressure is 0 psig and the maximum expected pressure is 2.8 bar (40 psig). Travel stops must be used to prevent excessive overtravel and undertravel since the maximum allowable overpressure and underpressure is higher than 5% of the 1.4 bar (20 psig) span which is ±70 mbar (±1 psig).
 3. Bourdon tube without travel stops may be pressured to this value without permanent zero shift.
 4. Bourdon tube with travel stops set may be pressured to this value without permanent zero shift.

Table 1-5. Optional Process Connections

INPUT RANGE		CONNECTION	
Bar	Psig	Size	Material
Up to 0 to 400	Up to 0 to 5000	■ 1/2 NPT external or ■ 1/2 NPT internal	■ Steel or ■ stainless steel
0 to 400 to 0 to 600	0 to 5000 to 0 to 10,000	1/2 NPT internal	Stainless steel
0 to 400 to 0 to 600	0 to 5000 to 0 to 10,000	1/2 NPT external	Stainless steel

Table 1-6. Supply Pressure Data

Output Range Signal	Normal Operating Supply Pressure ⁽¹⁾	Maximum Pressure Limit ⁽²⁾
Bar	0.2 to 1.0	1.4
	0.4 to 2.0	2.4
Psig	3 to 15	20
	6 to 30	35

1. If this pressure is exceeded, control may be impaired.
 2. If this pressure is exceeded, damage to the controller may result.

Section 2 Installation

⚠ WARNING

To avoid personal injury or property damage resulting from the sudden release of pressure:

- Always wear protective clothing, gloves, and eyewear when performing any installation operations.
- Personal injury or property damage may result from fire or explosion if natural gas is used as the supply medium and preventive measures are not taken. Preventive measures may include, but are not limited to, one or more of the following: Remote venting of the unit, re-evaluating the hazardous area classification, ensuring adequate ventilation, and the removal of any ignition sources. For information on remote venting of this controller, refer to page 14.
- Check with your process or safety engineer for any additional measures that must be taken to protect against process media.
- If installing into an existing application, also refer to the WARNING at the beginning of the Maintenance section of this instruction manual.

Controller Mounting Orientation

Mount the controller with the housing vertical, as shown in figure 2-1, so the vent points down.

Figure 2-1. Typical Actuator Mounting

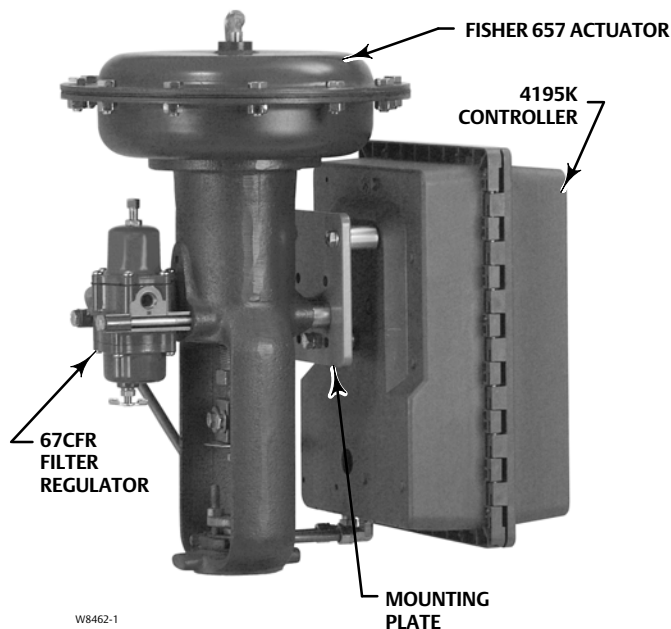

Pipestand Mounting

Refer to figure 2-2. Pipestand mounting parts are provided to mount the controller to a 2-inch (nominal) pipe. Attach a bracket (key 68) to the controller with cap screws (key 66) and lock washers (key 67). Attach two clamps (key 69) to the bracket and fasten the controller to the pipe.

Figure 2-2. Pipestand Mounting

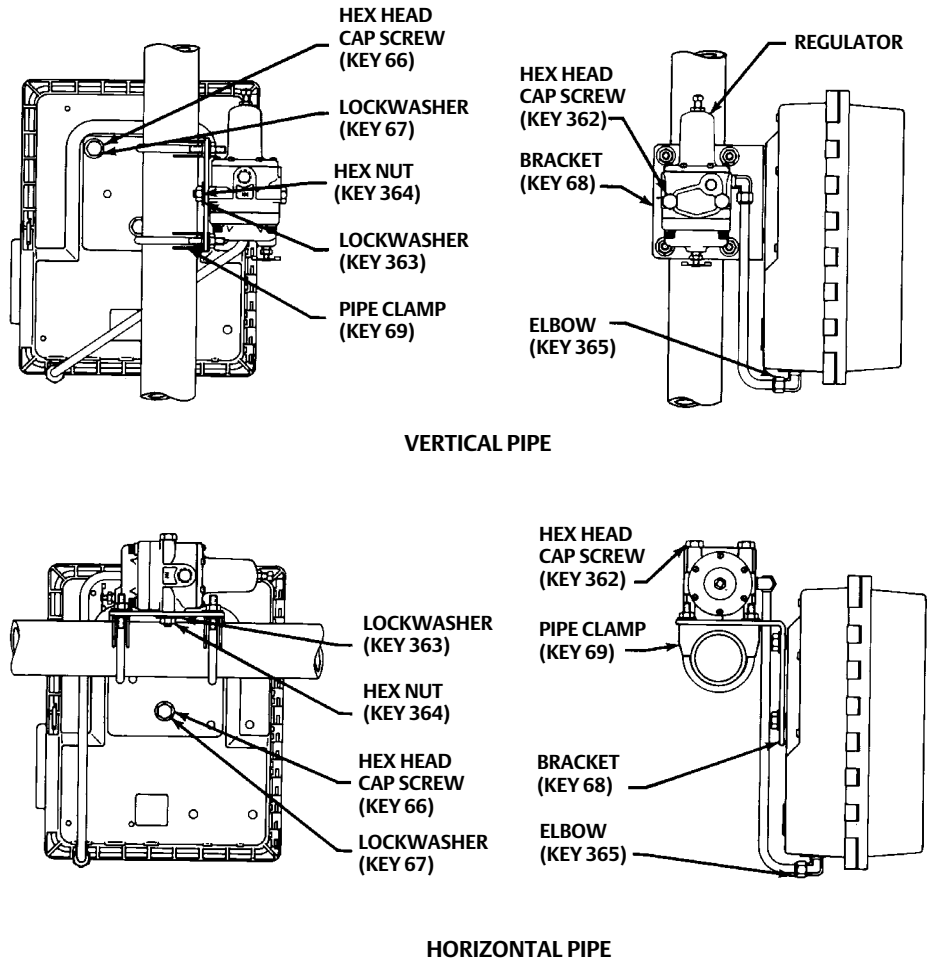

49A3196-A
A6732

Panel Mounting

Using the dimensions shown in figure 2-3, cut a hole in the panel surface. Slide the controller into the hole and attach the bracket (key 68) to the rear of the controller using three cap screws (key 66) and lock washers (key 67). Tighten the screws (key 70) to seat the case snugly and evenly against the panel surface.

Figure 2-3. Panel Mounting

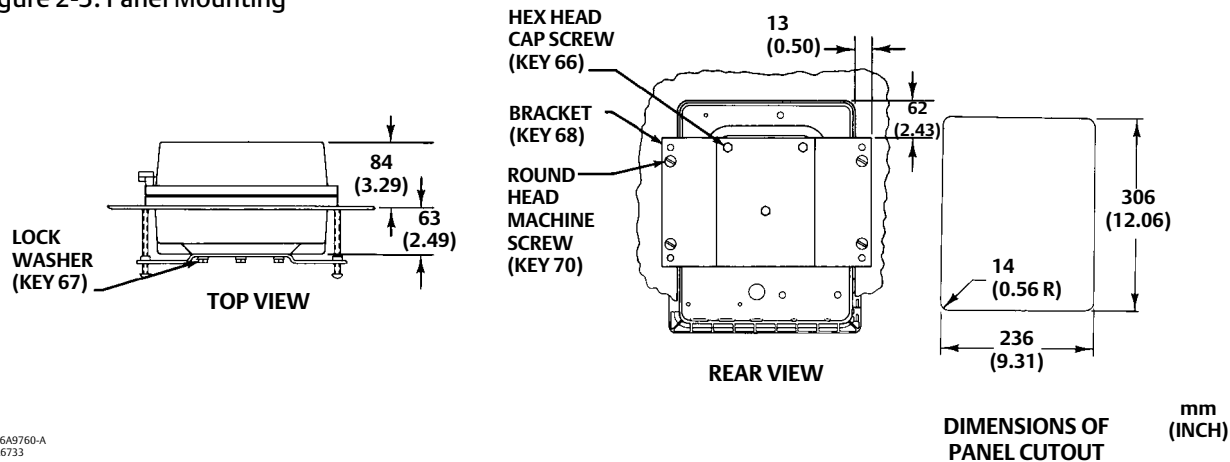

36A9760-A
A6733

Wall Mounting

Using the dimensions in figure 2-4, drill holes in the wall to align with the four holes in the bracket (key 68). If the tubing is to run through the wall, drill a hole in the wall large enough to accept the tubing. Mount the controller to the bracket using three cap screws (key 66) and lock washers (key 67). Attach the bracket to the wall, using suitable screws or bolts.

Figure 2-4. Wall Mounting

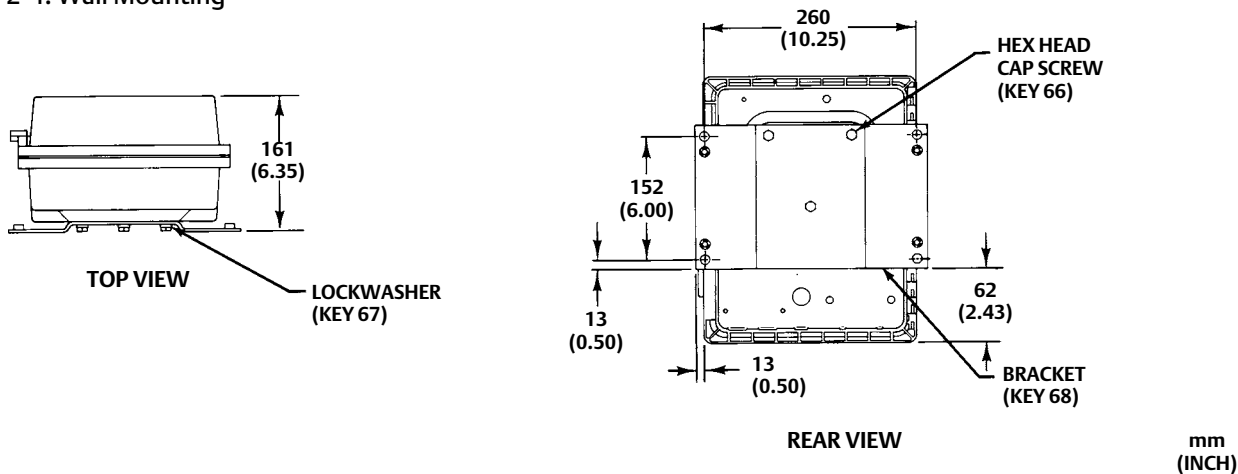

36A9761-B
A6734

Actuator Mounting

Refer to figure 2-1. A controller specified for mounting on a control valve actuator is mounted at the factory. If the controller is ordered separately for installation on a control valve actuator, mount the unit as described in this section. Mounting parts vary for different actuator types.

Attach the mounting bracket to the actuator yoke with cap screws, lock washers, and spacer spools. Attach the controller to the bracket with cap screws, lock washers, and spacer spools. On some designs, the mounting bracket is attached to the actuator casing rather than to the yoke.

Pressure Connections

⚠ WARNING

To avoid personal injury or property damage resulting from the sudden release of pressure, do not install any system component where service conditions could exceed the limits given in this manual. Use pressure-relieving devices as required by government or accepted industry codes and good engineering practices.

Refer to figure 2-5 for pressure connection locations. Supply, output, remote set point, external feedback, and vent connections are 1/4 NPT, internal. Process pressure connections are 1/4 or 1/2 NPT (optional). Use 1/4-inch or 3/8-inch pipe or tubing for supply, output, remote set point, and external feedback connections.

Process Pressure Connection

The connection marked A on the bottom of the case is the process input for all Bourdon tube controllers and those capsular element controllers used in vacuum pressure applications. The connection marked B is the process input for capsular element controllers used in positive pressure and compound pressure applications. See figure 2-5 for the location of the A and B connections.

When installing process piping, follow accepted practices to ensure accurate transmission of the process pressure to the controller. Install a three-valve bypass, shutoff valves, vents, drains, or seal systems as needed in the process pressure lines. If necessary, install a needle valve in a process pressure sensing line to dampen pulsations.

If the instrument is located such that the adjacent process pressure lines are approximately horizontal, the lines should slope downward to the instrument for liquid-filled lines and upward toward the instrument for gas-filled lines. This reduces the possibility of air becoming trapped in the sensor with liquid-filled lines or of condensation becoming trapped in gas-filled lines. The recommended slope is 83 millimeters per m (1 inch per foot).

If the controller is being used in conjunction with a control valve to control pipeline pressure, connect the process pressure line in a straight section of pipe approximately 10 pipe diameters away from the valve and also away from bends, elbows, and areas of abnormal fluid velocities. For pressure-reducing service, the process pressure line must be connected downstream of the control valve. For pressure-relief service, the process pressure line must be connected upstream of the control valve.

Supply Pressure Connection

⚠ WARNING

Severe personal injury or property damage may occur if the instrument air supply is not clean, dry and oil-free, or noncorrosive gas. While use and regular maintenance of a filter that removes particles larger than 40 micrometers in diameter will suffice in most applications, check with an Emerson Process Management field office and industry instrument air quality standards for use with corrosive gas or if you are unsure about the proper amount or method of air filtration or filter maintenance.

Supply pressure must be clean, dry air or noncorrosive gas that meets the requirements of ISA 7.0.01. A maximum 40 micrometer particle size in the air system is acceptable. Further filtration down to 5 micrometer particle size is recommended. Lubricant content is not to exceed 1 ppm weight (w/w) or volume (v/v) basis. Condensation in the air supply should be minimized. Natural gas must be clean, dry, oil-free, and noncorrosive. H₂S content should not exceed 20 ppm.

Use a suitable supply pressure regulator to reduce the supply pressure source to the normal operating supply pressure shown in table 1-6. Connect supply pressure to the SUPPLY connection on the bottom of the case, shown in figure 2-5.

Remote Set Point (suffix letter M) Pressure Connection

If the controller has remote set point (suffix letter M), connect the remote set point pressure to the top of the controller case at the location shown in figure 2-5. Use clean, dry air or noncorrosive gas. Use a 0.2 to 1.0 bar (3 to 15 psig) remote set point pressure range for a 0.2 to 1.0 bar (3 to 15 psig) controller output signal range or a 0.4 to 2.0 bar (6 to 30 psig) remote set point pressure range for a 0.4 to 2.0 bar (6 to 30 psig) controller output signal range. If pressure is supplied to the remote set point connection with a regulator, a small bleed orifice should be placed between the regulator and remote set point connection to prevent pressure variations due to regulator lock-up.

External Feedback Pressure Connection (4195KB Controllers Only)

When a secondary controller in an override application has this option, reset windup is minimized in the secondary controller. Connect the external feedback connection of the secondary controller to the output of the customer-supplied high or low select relay (see figures 2-5 and 4-9).

Figure 2-5. Connection Locations

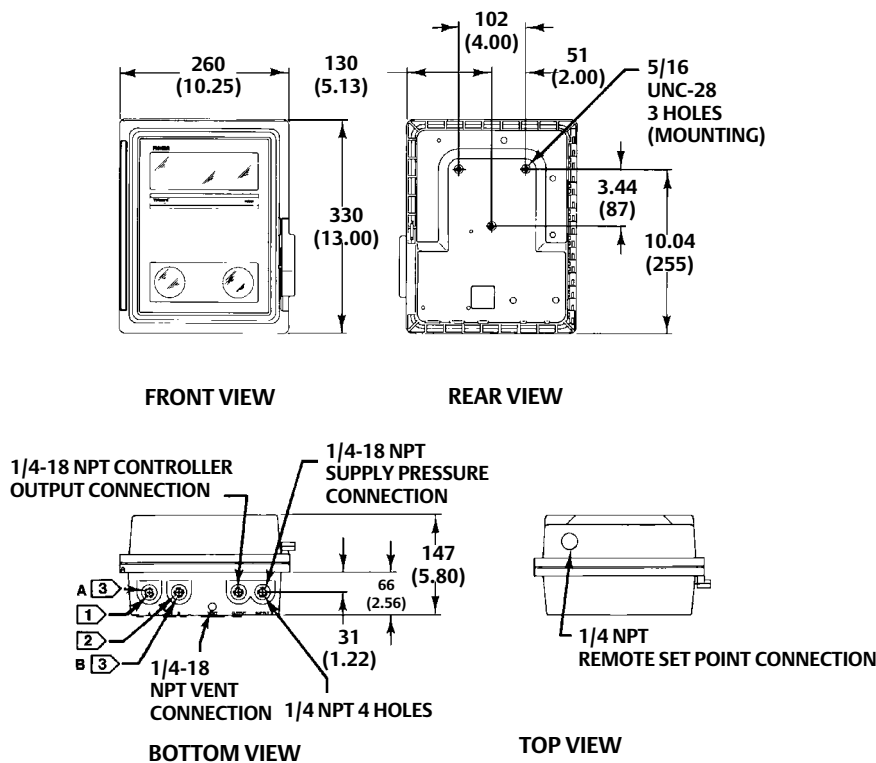

NOTES:

- ① 1/4-18 NPT PROCESS CONNECTION (MARKED A) FOR ALL BOURDON TUBE CONTROLLERS AND FOR THOSE CAPSULAR ELEMENT CONTROLLERS USED IN VACUUM PRESSURE APPLICATIONS.
- ② 1/4-18 NPT PROCESS CONNECTION (MARKED B) FOR CAPSULAR ELEMENT CONTROLLERS USED IN POSITIVE AND COMPOUND PRESSURE APPLICATIONS.
- ③ FOR THE EXTERNAL FEEDBACK CONNECTIONS (4195KB CONTROLLERS ONLY), EITHER THE A OR B CONNECTION IS USED, DEPENDING ON THE LOCATION OF THE PROCESS CONNECTION.

46A9765-A
A2892-4

mm
(INCH)

Vent

⚠ WARNING

Personal injury or property damage could result from fire or explosion of accumulated gas, or from contact with hazardous gas, if a flammable or hazardous gas is used as the supply pressure medium. Because the controller case and cover assembly do not form a gas-tight seal when the assembly is enclosed, a remote vent line, adequate ventilation, and necessary safety measures should be used to prevent the accumulation of flammable or hazardous gas. However, a remote vent pipe alone cannot be relied upon to remove all flammable or hazardous gas. Vent line piping should comply with local and regional codes and should be as short as possible with adequate inside diameter and few bends to reduce case pressure buildup.

CAUTION

When installing a remote vent pipe, take care not to over-tighten the pipe in the vent connection. Excessive torque will damage the threads in the connection.

If a remote vent is required, the vent line must be as short as possible with a minimum number of bends and elbows. Vent line piping should have a minimum inside diameter of 19 mm (3/4 inches) for runs up to 6.1 meters (20 feet) and a minimum inside diameter of 25 mm (1 inch) for runs from 6.1 to 30.5 meters (20 to 100 feet).

The vent must be protected against the entrance of any foreign material that could plug it; or if a remote vent is not required, the vent opening in the case must be protected against the entrance of any foreign material that could plug it. Check the vent periodically to be certain it is not plugged.

Section 3 4195KA Proportional-Only Controllers

Adjustments for 4195KA Controllers

This section includes descriptions of adjustments and procedures for prestartup, startup, and calibration. Adjustment locations are shown in figures 3-1 and 3-3. To better understand the adjustments and overall controller operation, refer to the Principle of Operation section and the schematic diagrams in figures 3-4 and 3-5. Unless otherwise noted, key numbers given in this section are found in figure 7-1.

Figure 3-1. Fisher 4195KA Controller Adjustment Locations

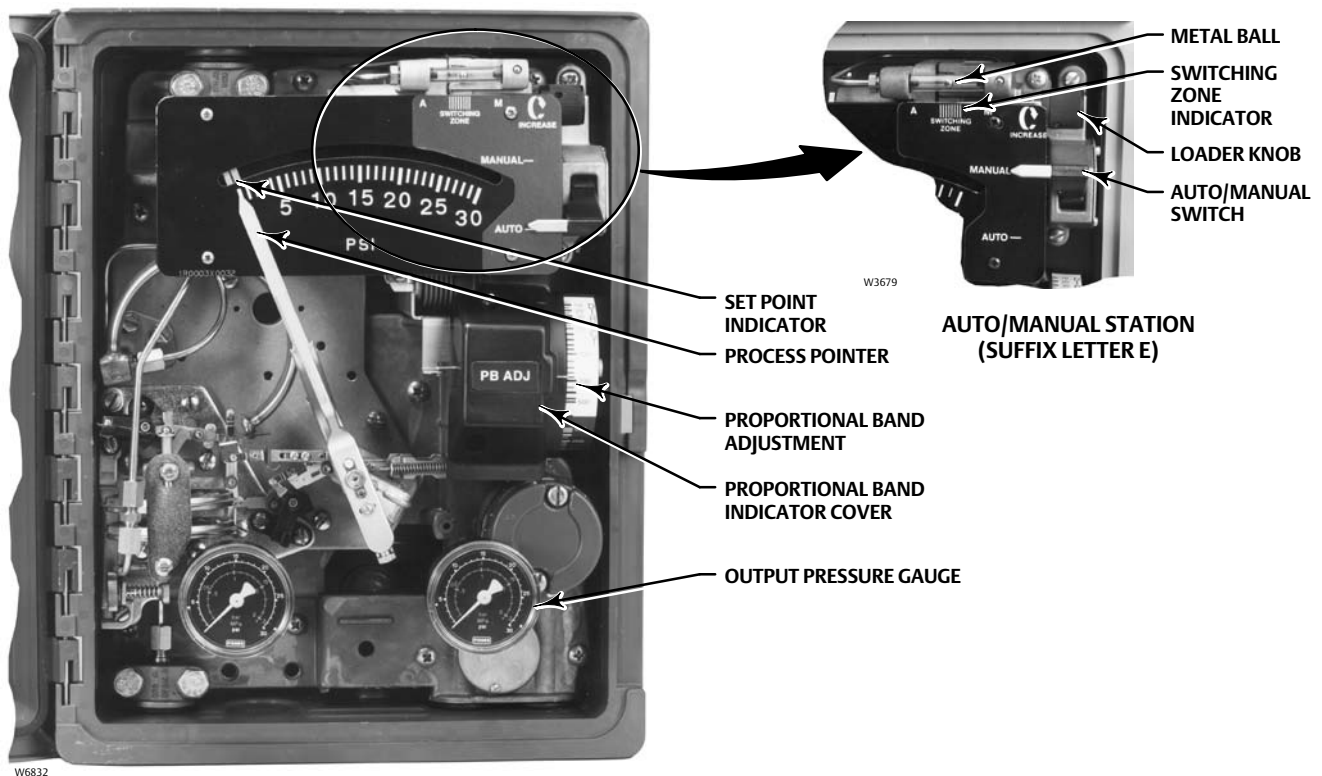

Manual Set Point Adjustment

Adjust the set point by moving the set point indicator until the line on the set point indicator is over the desired value on the process pressure scale. Move the indicator to the right to increase the set point and to the left to decrease it. Adjusting the set point does not affect the proportional band setting.

Remote Set Point (suffix letter M) Adjustment

CAUTION

Do not manually move the set point indicator on controllers with remote set point. Manually moving the set point indicator could damage the controller.

If the controller is equipped with remote set point (suffix letter M), vary the remote set point pressure to change the set point. Increase the pressure to increase the set point, and decrease the pressure to decrease the set point.

Proportional Band Adjustment (PB ADJ)

The proportional band determines the controller output sensitivity. The proportional band adjustment is marked in percentages of process pressure required to drive the controller from zero output to full output.

To adjust the proportional band, open the controller cover and locate the proportional band adjustment (PB ADJ) knob. Rotate the knob until the desired value is opposite the line on the proportional band indicator cover.

Changing Controller Action

To change the controller action from direct to reverse or vice versa, loosen the screws on the proportional band indicator cover. Lift the cover out as shown in figure 3-2 and rotate the proportional band adjustment to the desired action. Setting the proportional band to the values in the white portion of the adjustment provides direct controller action; setting proportional band in the black portion provides reverse controller action.

Figure 3-2. Changing Controller Action on Fisher 4195KA Controllers



W3439

Bourdon Tube or Capsular Element Controllers for Positive or Compound Pressure

- For direct control action—An increasing sensed pressure increases output pressure.
- For reverse control action—An increasing sensed pressure decreases output pressure.

Capsular Element Controllers for Vacuum Pressure

- For direct control action—An increasing sensed vacuum increases output pressure.

- For reverse control action—An increasing sensed vacuum decreases output pressure.

After changing the action, tighten the screws on the proportional band indicator cover.

Switching The Auto/Manual Station (suffix letter E)

Note

Switching the controller between automatic and manual, or manual and automatic mode, without balancing the outputs, can disturb the process and cause controller cycling.

Refer to figure 3-1 if the controller has the auto/manual station (suffix letter E). To switch from automatic to manual mode, or from manual to automatic, you must first balance the manual output with the controller output. Two balance methods are available to equalize the manual output with the controller output.

To switch from automatic to manual mode, carefully adjust the loader knob until the metal ball inside the plastic tube moves into the switching zone. Then move the automatic/manual switch to MANUAL. Turn the loader knob clockwise to increase the controller output or counterclockwise to decrease it.

To switch from manual to automatic mode, adjust the set point to move the ball into the switching zone. Turn the switch to AUTO and adjust the set point to control the output.

When the auto/manual switch is in AUTO, adjusting the loader knob has no effect on the controller output. When the auto/manual switch is in MANUAL, changing the set point has no effect on the controller output.

Prestartup Checks for 4195KA Controllers

Refer to figure 3-1 for adjustment locations and refer to figure 7-1 for key number locations.

When performing the checks, open loop conditions must exist. An open loop exists when the controller output does not affect the input pressure or other control signal to the controller.

Note

If the controller has the auto/manual station (suffix letter E), be sure the controller is in the automatic mode before performing the prestartup checks.

1. Provide a means of measuring the controller output pressure by connecting the controller output to a pressure gauge. Connect supply pressure to the supply pressure regulator and be sure it is delivering the proper supply pressure to the controller. Do not exceed the normal operating pressure in table 1-6.
2. For a controller with remote set point (suffix letter M), connect regulated pressure of 0.2 to 1.0 bar (3 to 15 psig) or 0.4 to 2.1 bar (6 to 30 psig) to the remote set point connection at the top of the controller case.
3. Remove the two machine screws (key 6) and lift off the proportional band indicator cover (key 36).
4. Adjust the set point a minimum of 20 percent of input span above the process pointer.
5. Adjust the proportional band for 5 percent DIRECT.
6. If necessary, connect a pressure source to the process connection and adjust the process pointer to the last mark on the left side of the scale. If the last scale mark is 0 psig, a pressure source is not required.

7. The controller output pressure should be 0 bar (0 psig).
8. Rotate the proportional band to 5 percent REVERSE.
9. The controller output should be within 0.14 bar (2 psig) of the supply pressure.
10. If the controller output is within tolerance, adjust the proportional band to 400 percent in the desired action, secure the proportional band indicator cover (key 36) with the machine screws (key 6), and go to the startup procedure. If the controller output pressure is not within tolerance, go to the 4195KA calibration procedure for recalibration.

Startup for 4195KA Controllers

Perform the prestartup checks and, if necessary, calibrate the controller prior to this procedure.

Note

When performing the startup procedures, keep in mind that the initial settings are guidelines. They will vary depending on the actual process being controlled.

1. Be sure the supply pressure regulator is delivering the proper supply pressure to the controller.
2. For controllers with:

Manual set point:

Move the set point adjustment to the desired set point.

Remote set point:

- a. See figure 2-5 for the location of the remote set point connection. Connect an adjustable pressure source to the remote set point connection.
- b. Adjust the pressure source until the set point indicator reaches the desired set point. Remember: Increasing the remote set point pressure increases the set point.
3. Set the proportional band adjustment to 100 percent for fast processes. For slow processes, calculate the proportional band percentage from the equation below:

$$\text{P.B.} = \frac{200 \times \text{Allowable Overshoot}}{\text{Pressure Span}}$$

For example:

$$\frac{200 \times 0.14 \text{ bar}}{2.1 \text{ bar}} \cong 13\%$$

4. Create a load upset by momentarily changing the set point. Check for system cycling. If the system does not cycle, lower the proportional band setting (thus raising the gain) and disturb the system again by changing the set point. Continue this procedure until the system cycles. At this point, double the proportional band setting (proportional band setting x2).
5. Check the stability of the recommended proportional band setting by introducing a disturbance and monitoring the process.

Calibration of 4195KA Controllers

WARNING

To avoid personal injury or property damage resulting from the sudden release of pressure, do not exceed the operating limits given in this manual.

General Calibration Instructions

Note

If the controller has the auto/manual station (suffix letter E), be sure the controller is in the automatic mode before performing calibration.

If the prestartup checks, or startup, reveal faulty controller operation, perform the calibration described in this section. These instructions are valid for either shop or field calibration, provided that open process loop conditions exist. Unless otherwise noted, key numbers are found in figure 7-1.

Do not use the gauges supplied with the controller during calibration. Monitor process pressure, supply pressure, controller output pressure, and if applicable, remote set point pressure with external gauges.

Process Indicator Zero and Span Calibration

Before starting this procedure:

- Provide a regulated process pressure to the controller and a means of measurement external to the controller.
- Provide a means of measuring the controller output pressure by connecting the controller output to a pressure gauge (open loop conditions must exist). Provide a regulated supply pressure to the controller. Do not exceed the normal operating pressure in table 1-6.

Refer to figures 3-1 and 3-3 for adjustment locations.

Note

Any change to the process pointer span adjustment will require readjustment of the process pointer zero adjustment.

Figure 3-3. Fisher 4195KA Controller Calibration Adjustment Locations

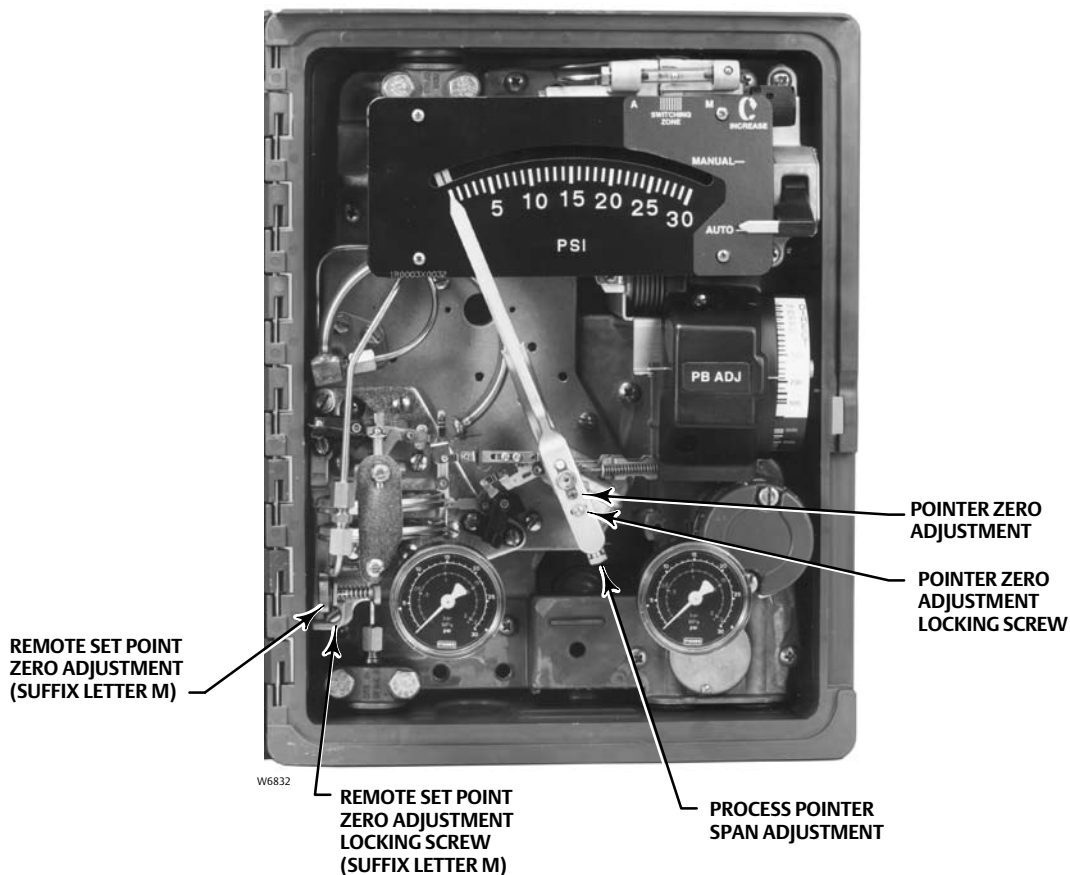

FRONT VIEW

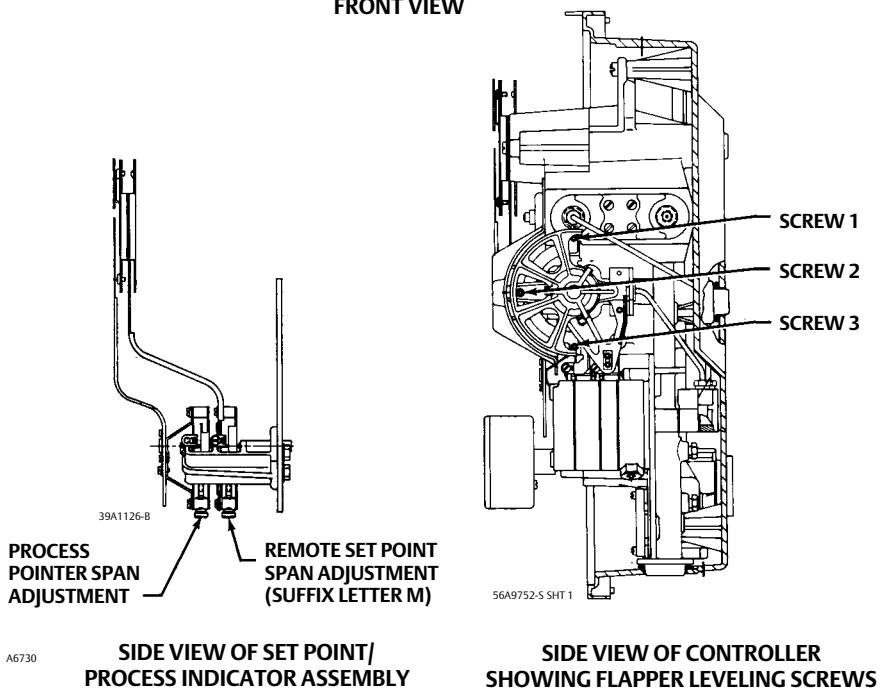

1. Remove the two screws (key 6) and lift off the proportional band indicator cover (key 36).
2. Set the proportional band between DIRECT and REVERSE.
3. Apply process pressure equal to the process scale span lower limit.
4. The process pointer should indicate the process scale lower limit. If not, adjust the process pointer to the process scale lower limit by loosening the zero adjustment locking screw and turning the zero adjustment screw. Tighten the zero adjustment locking screw.
5. Apply process pressure equal to the process scale span upper limit.
6. The process pointer should indicate the process scale upper limit. If not, adjust the span screw to correct one-half of the error as follows: clockwise to increase span for a low indication (below the upper limit); counterclockwise to decrease span for a high indication (above the upper limit).
7. Repeat steps 3 through 6 until the error is eliminated.
8. Apply process pressure equal to the mid-scale value of the process scale span. The process pointer should indicate the mid-scale mark, ± 2 percent of span. If the error is greater than ± 2 percent, refer to the Maintenance section and perform the appropriate zero and span adjustment procedure for a Bourdon tube or capsular element controller.
9. Adjust the process pointer to within ± 1 percent of the mid-scale mark by loosening the locking screw and turning the zero adjustment screw. This distributes the error over the entire scale span and brings all points within ± 1 percent of the process input span.
10. Apply process pressure equal to the process scale span lower limit.
11. The process pointer should indicate the process scale lower limit ± 1 percent of the scale span.
12. Apply process pressure equal to the process scale span upper limit.
13. The process pointer should indicate the process scale upper limit ± 1 percent of the scale span.
14. If the error is greater than ± 1 percent, repeat steps 3 through 13.

Remote Set Point (suffix letter M) Zero and Span Calibration

Refer to figures 3-1 and 3-3 for adjustment locations. Refer to figure 7-1 for key number locations.

Note

Any adjustment of the remote set point span adjustment screw requires readjustment of the remote set point zero adjustment screw.

1. Remove the two screws (key 6) and lift off the proportional band indicator cover (key 36).
2. Set the proportional band between DIRECT and REVERSE.
3. Apply remote set point pressure equal to the lower range limit.
4. The set point indicator should indicate the process scale lower limit. If not, loosen the remote set point zero adjustment locking screw and adjust the remote set point zero adjustment screw until the set point indicator aligns with the process scale lower limit. Tighten the zero adjustment locking screw.
5. Apply remote set point pressure equal to the upper range limit.
6. The set point indicator should indicate the process scale upper limit. If not, adjust the remote set point span adjustment screw to correct one-half the error as follows: clockwise to increase span for a low indication; counterclockwise to decrease span for a high indication.
7. Repeat steps 3 through 6 until the error is eliminated.
8. Apply remote set point pressure equal to the mid-range value.

9. Make sure the set point indicator is within ± 1 percent of the mid-scale mark and if so, proceed to step 12. If the set point indicator is not within 1 percent, but is within ± 2 percent of the mid-scale mark, then proceed with step 10. If the set point indicator is not within ± 2 percent, proceed to the remote set point calibration procedure in the Maintenance section.
10. Loosen the remote set point zero adjustment locking screw and adjust the remote set point zero adjustment screw to correct for half the error at mid-scale. Tighten the zero adjustment locking screw.
11. Apply remote set point pressure equal to the lower and upper range limits and make sure the set point indicator is within ± 1 percent.
12. If necessary, perform the process indicator zero and span calibration procedure in this section. Otherwise, perform the flapper alignment procedure in this section.

Flapper Alignment

Note

Perform the process indicator zero and span calibration procedure and, for controllers with remote set point (suffix letter M), the remote set point zero and span calibration procedure before the flapper alignment.

Flapper leveling screw numbers and adjustments are shown in figure 3-3. Key number locations are shown in figure 7-1.

Provide a means of measuring the controller output pressure by connecting the controller output to a pressure gauge (open-loop conditions must exist). Provide a regulated supply pressure to the controller. Do not exceed the normal operating pressure in table 1-6. After performing the flapper alignment procedure, go to the startup procedure.

1. For a controller with manual set point, move the set point indicator to the mid-scale mark on the process scale. For a controller with remote set point (suffix letter M), adjust the remote set point pressure until the set point indicator is at the mid-scale mark on the process scale.
2. Apply process pressure equal to the mid-scale value of the process scale span. If pressure is not available to pressure the input element to the mid-scale value, an alternate method is to disconnect link number 1 at the input element and tape the process pointer at the mid-scale mark on the process scale. If the controller has a capsular input element, note the hole from which link number 1 was removed for proper replacement. This method should only be used if pressure is not available to pressure the input element to the mid-scale value.
3. Remove the two machine screws (key 6) and lift off the proportional band indicator cover (key 36).
4. Adjust the proportional band between DIRECT and REVERSE.
5. The controller output should be 0.62 ± 0.007 bar (9 ± 0.10 psig) for a 0.2 to 1.0 bar (3 to 15 psig) output or 1.2 ± 0.01 bar (18 ± 0.2 psig) for a 0.4 to 2.0 bar (6 to 30 psig) output. If not, adjust flapper leveling screw 2 (the screw nearest the nozzle) until the output is within tolerance.
6. Set the proportional band to 30 percent DIRECT.
7. The controller output should be 0.62 ± 0.02 bar (9 ± 0.25 psig) or 1.2 ± 0.04 bar (18 ± 0.5 psig). If not, adjust flapper leveling screw 3 (the screw nearest the nozzle).
8. Set the proportional band to 30 percent REVERSE.
9. The controller output should be 0.62 ± 0.02 bar (9 ± 0.25 psig) or 1.2 ± 0.04 bar (18 ± 0.5 psig). If not, adjust flapper leveling screw 1 (the screw nearest the nozzle).
10. Repeat steps 4 through 9 until the controller output remains in tolerance without further leveling screw adjustments.
11. If link 1 was disconnected, remove the tape and reconnect link 1 to the input element.

- Set the proportional band to 400 percent in the desired controller action and replace the proportional band indicator cover.

Principle of Operation for 4195KA Controllers

Overall Operation

Refer to the schematic diagram in figure 3-4.

Figure 3-4. Fisher 4195KA Controller Schematic

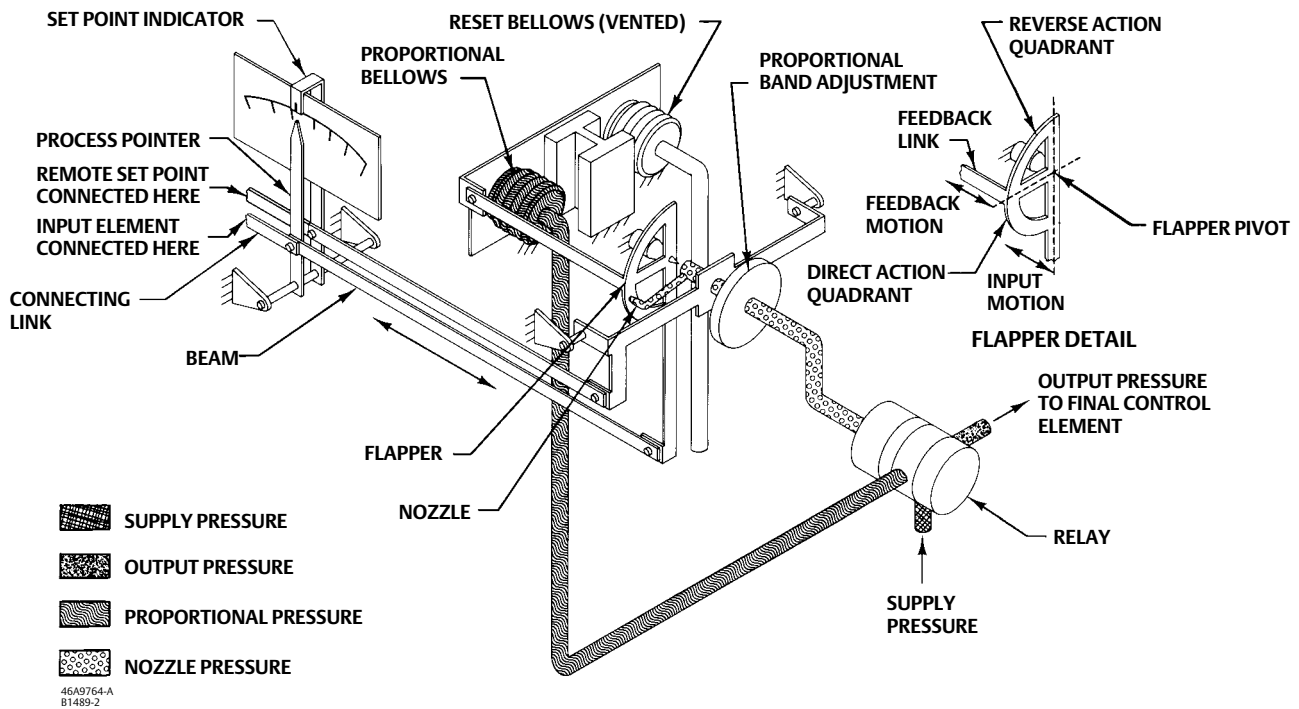

The input element is connected to the process pointer and to the flapper by connecting links. As the process pressure increases (in a direct-acting controller), the flapper moves toward the nozzle, restricting flow through the nozzle and increasing nozzle pressure. When this occurs, relay action increases the output pressure (delivery) of the controller. Output pressure is fed back to the proportional bellows. The action of the proportional bellows counteracts the flapper movement that resulted from the process pressure change and backs the flapper away from the nozzle until equilibrium is reached.

Moving the set point indicator changes the distance between the nozzle and flapper as does a change in process pressure, except that when the set point is changed, the nozzle moves with respect to the flapper.

The proportional band adjustment positions the nozzle on the flapper. Increasing (widening) the proportional band moves the nozzle to a position on the flapper where less input and more feedback motion occurs, which decreases the gain of the controller. Decreasing (narrowing) the proportional band moves the nozzle toward a position where more input and less feedback motion occurs, which increases the gain. The controller action is changed from direct to reverse by turning the proportional band adjustment to position the nozzle on the flapper quadrant to a point where the direction of the flapper motion versus input motion is reversed as shown in the flapper detail of figure 3-4. With the controller in the reverse-acting mode, an increase in process pressure causes a decrease in output pressure.

Remote Set Point (suffix letter M) Operation

The capability to adjust the controller set point from a remote location is available with all 4195KA controllers. This option is designated by the letter M in the type number.

A control pressure is applied to the capsular element within the remote set point assembly. The expansion and contraction of the capsule moves the set point adjustment via a connecting linkage. Increasing the control pressure to the capsule increases the set point setting and decreasing the control pressure reduces the set point setting.

Auto/Manual Station (suffix letter E) Operation

A controller with the auto/manual station (designated by the suffix letter E in the type number) has piping on the output side of the relay as shown in figure 3-5. Supply pressure to the relay is also applied to the manual loader. The manual loader, functioning as a regulator, applies pressure to one side of the plastic tube and to the auto/manual switch. Output pressure from the relay registers on the other side of the plastic tube as well as in the auto/manual switch. Output pressure from the relay registers on the other side of the plastic tube as well as in the auto/manual switch.

Figure 3-5. Fisher 4195KA Auto/Manual Station Schematic

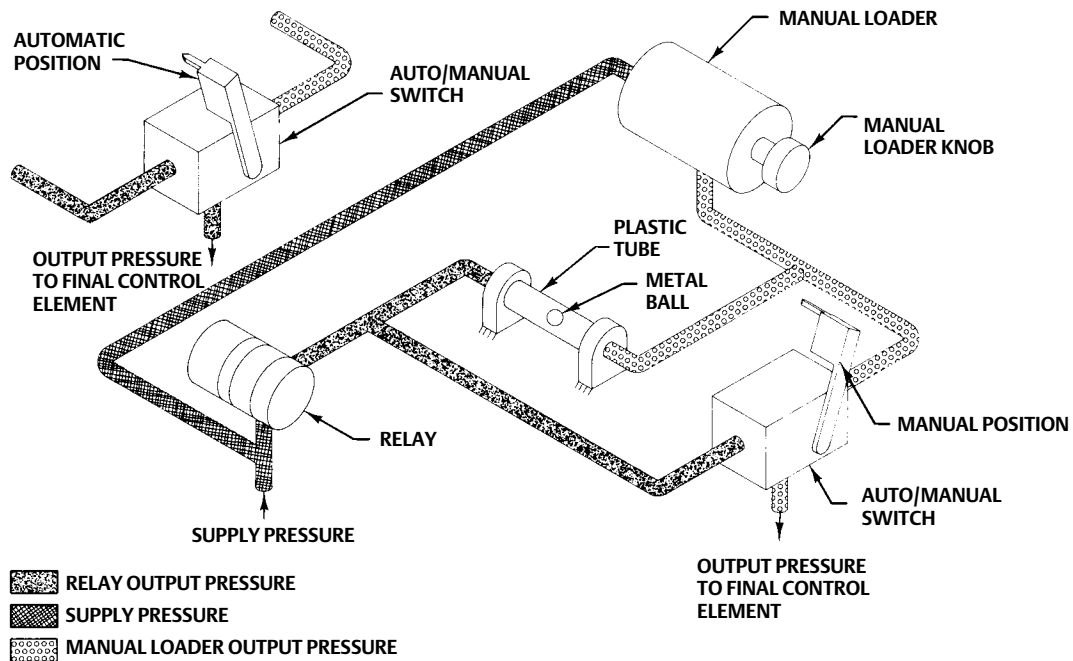

48A5230-A
A2999-1

When the auto/manual switch is in the MANUAL position, the manual loader output is channeled through the auto/manual switch and becomes the controller output. When the auto/manual switch is in the AUTO position, the relay output is channeled through the switch to become the controller output.

Before the auto/manual switch is operated, the relay output must equal the manual loader output to avoid bumping the process. Adjusting the set point varies the pressure on the left-hand side of the plastic tube. Adjusting the manual loader knob varies the pressure on the right-hand side. When the pressures are equal, the metal ball is centered in the tube and it is held in place by a small magnet. A pressure imbalance forces the ball to one end of the tube where it forms a seal, blocking air flow through the tube.

Section 4 4195KB Proportional-Plus-Reset Controllers and 4195KC Proportional-Plus-Reset-Plus-Rate Controllers

Adjustments for 4195KB and KC Controllers

This section includes descriptions of adjustments and procedures for prestartup, startup, and calibration. Adjustment locations are shown in figures 4-1 and 4-3. To better understand the adjustments and overall controller operation, refer to the Principle of Operation section and to the schematic diagrams in figures 4-5 through 4-9. Unless otherwise noted, key numbers given in this section are found in figure 7-1.

Figure 4-1. Fisher 4195KB and KC Controller Adjustment Locations

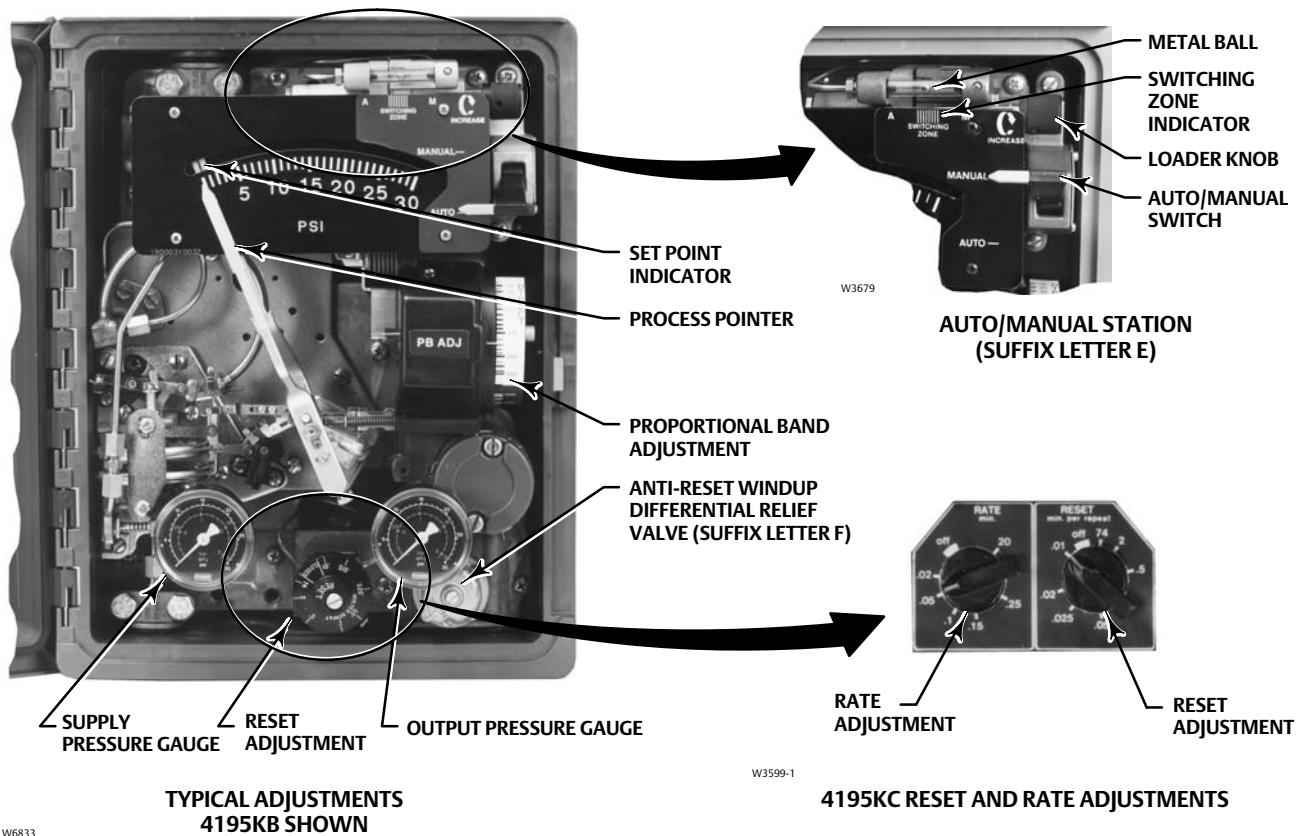

Manual Set Point Adjustment

Adjust the set point by opening the controller cover and moving the set point indicator until the line on the set point indicator is over the desired value on the process pressure scale. Move the indicator to the right to increase the set point and to the left to decrease it. Adjusting the set point does not affect the proportional band setting.

Remote Set Point (suffix letter M) Adjustment

CAUTION

Do not manually move the set point indicator on a controller with remote set point. Manually moving the set point indicator could damage the controller.

If the controller is equipped with remote set point (suffix letter M), vary the remote set point pressure to change the set point. Increase the pressure to increase the set point and decrease the pressure to decrease the set point.

Proportional Band Adjustment (PB ADJ)

The proportional band determines the controller output sensitivity. The proportional band adjustment is marked in percentages of process pressure required to drive the controller from zero output to full output.

To adjust the proportional band, open the controller cover and locate the proportional band adjustment (PB ADJ) knob. Rotate the knob until the desired value is opposite the line on the proportional band indicator cover.

Changing Controller Action

To change the controller action from direct to reverse or vice versa, loosen the screws on the proportional band indicator cover. Lift the cover out as shown in figure 4-2 and rotate the proportional band adjustment to the desired action. Setting the proportional band to the values in the white portion of the adjustment provides direct controller action; setting proportional band in the black portion provides reverse controller action.

Figure 4-2. Changing Controller Action on Fisher 4195KB and KC Controllers



W3439

Bourdon Tube or Capsular Element Controllers for Positive or Compound Pressure

- For direct control action— An increasing sensed pressure increases output pressure.
- For reverse control action— An increasing sensed pressure decreases output pressure.

Capsular Element Controllers for Vacuum Pressure

- For direct control action— An increasing sensed vacuum increases output pressure.
- For reverse control action— An increasing sensed vacuum decreases output pressure.

After changing the action, tighten the screws on the proportional band indicator cover.

Reset Adjustment

To adjust reset, open the controller cover and locate the RESET adjustment. Rotate the adjustment clockwise to decrease the minutes per repeat or counterclockwise to increase the minutes per repeat. Increasing the minutes per repeat provides a slower reset action.

Rate Adjustment

To adjust rate, open the controller cover and locate the RATE adjustment. Rotate the adjustment clockwise to decrease the minutes (less rate action) or counterclockwise to increase the minutes (more rate action).

Anti-Reset Windup (suffix letter F) Adjustment

If the arrow on the relief valve points toward the bottom of the controller case, as shown in figure 4-1, the valve opens with increasing controller output pressure. If the arrow points in the opposite direction, the relief valve opens with decreasing controller output pressure. Differential relief pressure is factory set at 0.3 bar (5 psig). Maximum relief pressure is 0.5 bar (7 psig). The minimum is 0.1 bar (2 psig).

Turn the adjusting screw counterclockwise to increase differential relief pressure, clockwise to decrease it.

Switching the Auto/Manual Station (suffix letter E)

Note

Switching the controller between automatic and manual, or manual and automatic mode, without balancing the outputs, can disturb the process and cause controller cycling.

Refer to figure 4-1 if the controller has the auto/manual station (suffix letter E). To switch from automatic to manual mode, or from manual to automatic, you must first balance the manual output with the controller output. Two balance methods are available to equalize the manual output with the controller output.

To switch from automatic to manual mode, carefully adjust the loader knob until the metal ball inside the plastic tube moves into the switching zone. Then move the automatic/manual switch to MANUAL. Turn the loader knob clockwise to increase the controller output or counterclockwise to decrease it.

To switch from manual to automatic mode, adjust the set point to move the ball into the switching zone. Turn the switch to AUTO and adjust the set point to control the output.

When the automatic/manual switch is in AUTO, adjusting the loader knob has no effect on the controller output. When the automatic/manual switch is in MANUAL, changing the set point has no effect on the controller output.

Prestartup Checks for 4195KB and KC Controllers

Refer to figure 4-1 for adjustment locations, and refer to figure 7-1 for key number locations.

When performing the checks, open loop conditions must exist. An open loop exists when the controller output does not affect the input pressure or other control signal to the controller.

Note

If the controller has the auto/manual station (suffix letter E), be sure the controller is in the automatic mode before performing prestartup checks. If the controller has the external feedback option, connect the controller output connection to the external feedback connection (see figure 2-5). Adjust the controller for full output pressure and with the RESET knob adjusted to 0.01 minutes/repeat, verify the tubing connections do not leak. Disconnect after completing the prestartup checks.

1. Provide a means of measuring the controller output pressure by connecting the controller output to a pressure gauge. Connect supply pressure to the supply pressure regulator and be sure it is delivering the proper supply pressure to the controller. Do not exceed the normal operating pressure in table 1-6.
2. For a controller with remote set point (suffix letter M), connect regulated pressure of 0.2 to 1.0 bar (3 to 15 psig) or 0.4 to 2.1 bar (6 to 30 psig) to the remote set point connection at the top of the controller case.
3. Remove the two machine screws (key 6) and lift off the proportional band indicator cover (key 36).
4. Adjust the set point a minimum of 20 percent of input span above the process pointer.
5. Turn the reset adjustment to 0.01 minutes per repeat.
6. Turn the rate adjustment to OFF (4195KC controllers).
7. Adjust the proportional band for 5 percent DIRECT.
8. If necessary, connect a pressure source to the process connection and adjust the process pointer to the last mark on the left side of the scale. If the last scale mark is 0 bar (0 psig), a pressure source is not required.
9. The controller output pressure should be 0 bar (0 psig).
10. Rotate the proportional band to 5 percent REVERSE.
11. The controller output should be within 0.14 bar (2 psig) of the supply pressure.
12. If the controller output is within tolerance, adjust the proportional band to 400 percent in the desired action. Secure the proportional band indicator cover (key 36) with the machine screws (key 6), and go to the startup procedure. If the controller output pressure is not within tolerance, go to the 4195KB and KC calibration procedure for recalibration.

Startup for 4195KB and KC Controllers

Perform the prestartup checks and, if necessary, calibrate the controller prior to this procedure.

Note

When performing the startup procedures, keep in mind that the initial settings are guidelines. They will vary depending on the actual process being controlled.

1. Be sure the supply pressure regulator is delivering the proper supply pressure to the controller.
2. For controllers with:

Manual set point:

Move the set point indicator to the desired set point.

Remote set point:

- a. See figure 2-5 for the location of the remote set point connection. Connect an adjustable pressure source to the remote set point connection.
 - b. Adjust the pressure source until the set point indicator reaches the desired set point. Remember: Increasing the remote set point pressure increases the set point.
3. Set the reset adjustment to 0.05 minutes per repeat for fast processes. Set it to 0.5 minutes per repeat for slow processes. For controllers with rate, set the rate adjustment to OFF.
 4. Set the proportional band to 100 percent for fast processes. For slow processes, calculate the proportional band percentage from the equation below:

$$P.B. = \frac{200 \times \text{Allowable Overshoot}}{\text{Pressure Span}}$$

For example:

$$\frac{200 \times 0.14 \text{ bar}}{2.1 \text{ bar}} \cong 13\%$$

5. If the controller is used in conjunction with a control valve, return the control valve to service by slowly opening the upstream and downstream manual control valves in the pipeline. Close the manual bypass valve, if one is used.
6. Tune the various controller actions.

Tuning proportional action: Create a load upset by momentarily changing the set point. Check for system cycling. If the system does not cycle, lower the proportional band setting (thus raising the gain) and disturb the system again by changing the set point. Continue this procedure until the system cycles. At this point, double the proportional band setting (proportional band setting $\times 2$).

Tuning reset action: Disturb the system. If the system does not cycle, speed up the reset by changing the setting to a lower value (faster reset). Disturb the system again. Continue this procedure until the system cycles. When the system cycles, multiply the reset time setting by a factor of three (reset setting $\times 3$) and slow down the reset by changing the reset setting to the higher value. The reset is now tuned.

Tuning rate action: For a controller with rate (4195KC controllers), adjust the rate toward the higher setting until cycling occurs. When the system cycles, divide the rate value by a factor of three (rate setting $\div 3$) and decrease the rate by changing the setting to the lower value. The rate is now tuned.

7. Check the stability of the recommended proportional band setting by introducing a disturbance and monitoring the process.
8. Once stable control is attained, the process pointer and set point indicator should be in line. If they are aligned, return the set point to the desired value. If they are not, readjust the set point to the desired control point and proceed with step 9.
9. If the process pointer is within 5 percent of the set point indicator, turn the link 3 adjustment (see figure 6-13 or 6-21 for location) until the process pointer aligns with the set point indicator. Turn the link 3 adjustment screw clockwise to increase the process indication or counterclockwise to decrease it. If the process pointer is misaligned with the set point indicator by more than 5 percent of the scale span, perform the calibration procedures for 4195KB and KC controllers.

Calibration of 4195KB and KC Controllers

⚠ WARNING

To avoid personal injury or property damage resulting from the sudden release of pressure, do not exceed the operating limits given in this manual.

General Calibration Instructions

Note

If the controller has the auto/manual station (suffix letter E), be sure the controller is in the automatic mode before performing calibration.

If the prestartup checks, or startup, reveal faulty controller operation, perform the calibration described in this section. These instructions are valid for either shop or field calibration, provided that open loop conditions exist. Unless otherwise noted, key numbers are found in figure 7-1.

Do not use the gauges supplied with the controller during calibration. Monitor process pressure, supply pressure, controller output pressure, and if applicable, remote set point pressure with external gauges.

Process Indicator Zero and Span Calibration

Before starting this procedure:

- Provide a regulated process pressure to the controller and a means of measurement external to the controller.
- Provide a means of measuring the controller output pressure by connecting the controller output to a pressure gauge (open-loop conditions must exist). Provide a regulated supply pressure to the controller. Do not exceed the normal operating pressure in table 1-6.

Refer to figures 4-1 and 4-3 for adjustment locations.

Note

Any change to the process pointer span adjustment will require readjustment of the process pointer zero adjustment.

1. Remove the two screws (key 6) and lift off the proportional band indicator cover (key 36).
2. Set the proportional band between DIRECT and REVERSE.
3. Apply process pressure equal to the process scale span lower limit.

Figure 4-3. Fisher 4195KB and KC Controller Calibration Adjustment Locations

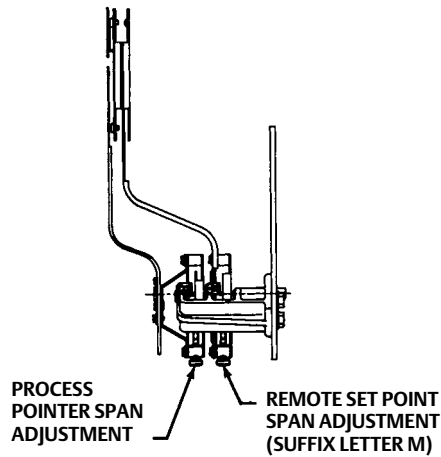
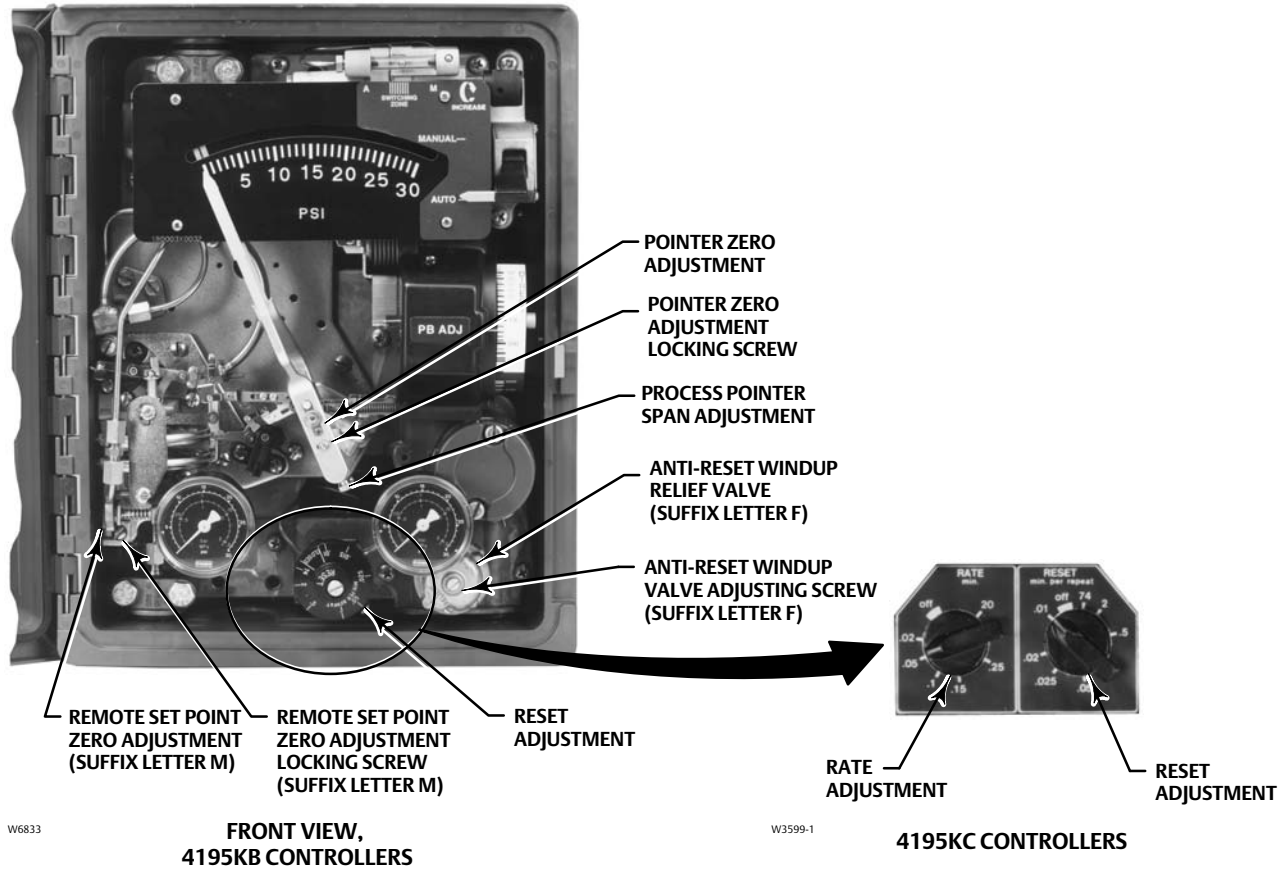

SIDE VIEW OF SET POINT/PROCESS INDICATOR ASSEMBLY

39A1126-B
A6731

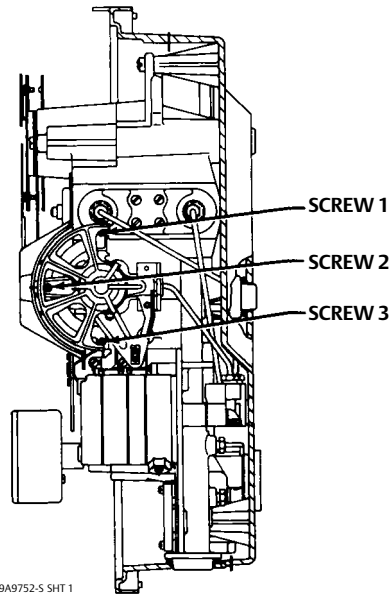

59A9752-S SHT 1

SIDE VIEW OF CONTROLLER SHOWING FLAPPER LEVELING SCREWS

4. The process pointer should indicate the process scale lower limit. If not, adjust the process pointer to the process scale lower limit by loosening the zero adjustment locking screw and turning the zero adjustment screw. Tighten the zero adjustment locking screw.
5. Apply process pressure equal to the process scale span upper limit.
6. The process pointer should indicate the process scale upper limit. If not, adjust the process pointer span screw to correct one-half the error as follows: clockwise to increase span for a low indication (below the upper limit); counterclockwise to decrease span for a high indication (above the upper limit).
7. Repeat steps 3 through 6 until the error is eliminated.
8. Apply process pressure equal to the mid-scale value on the process scale span. The process pointer should indicate the mid-scale mark, ± 2 percent of span. If the error is greater than ± 2 percent, refer to the Maintenance section and perform the appropriate zero and span adjustment procedure for Bourdon tube or capsular element controllers.
9. Adjust the process pointer to within ± 1 percent of the mid-scale mark by loosening the zero adjustment locking screw and turning the zero adjustment screw. This distributes the error over the entire scale range and brings all points within ± 1 percent of the process scale span.
10. Apply process pressure equal to the process scale lower limit.
11. The process pointer should indicate the process scale lower limit ± 1 percent of the scale span.
12. Apply process pressure equal to the process scale upper limit.
13. The process pointer should indicate the process scale upper limit ± 1 percent of the process scale span.
14. If the error is greater than ± 1 percent, repeat steps 3 through 13.

Remote Set Point (suffix letter M) Zero and Span Calibration

Refer to figures 4-1 and 4-3 for adjustment locations. Refer to figure 7-1 for key number locations.

Note

Any adjustment of the remote set point span adjustment screw requires readjustment of the remote set point zero adjustment screw.

1. Remove the two screws (key 6) and lift off the proportional band indicator cover (key 36).
2. Set the proportional band between DIRECT and REVERSE.
3. Apply remote set point pressure equal to the lower range limit.
4. The set point indicator should indicate the process scale lower limit. If not, loosen the remote set point zero adjustment locking screw and adjust the remote set point zero adjustment screw until the set point indicator aligns with the process scale lower limit. Tighten the zero adjustment locking screw.
5. Apply remote set point pressure equal to the upper range limit.
6. The set point indicator should indicate the process scale upper limit. If not, adjust the remote set point span adjustment screw to correct one-half the error as follows: clockwise to increase span for a low indication; counterclockwise to decrease span for a high indication.
7. Repeat steps 3 through 6 until the error is eliminated.
8. Adjust the remote set point pressure to the mid-range value.
9. Make sure the set point indicator is within ± 1 percent of the mid-scale mark, and if so, proceed to step 12. If the set point indicator is not within 1 percent, but is within ± 2 percent of the mid-scale mark, proceed with step 10. If the set point indicator is not within ± 2 percent, proceed to the remote set point zero and span adjustment procedure in the Maintenance section.

10. Loosen the remote set point zero adjustment locking screw and adjust the remote set point zero adjustment screw to correct for half the error at mid scale. Tighten the zero adjustment locking screw.
11. Apply remote set point pressure equal to the lower and upper range limits and make sure the set point indicator is within ± 1 percent.
12. If necessary, perform the process indicator zero and span calibration procedure in this section. Otherwise, perform the flapper alignment procedure in this section.

Flapper Alignment

Note

Perform the process indicator zero and span calibration procedure and, for controllers with remote set point (suffix letter M), the remote set point zero and span calibration procedure before the flapper alignment.

Flapper leveling screw numbers and adjustments are shown in figure 4-3. Key number locations are shown in figure 7-1.

Provide a means of measuring the controller output pressure by connecting the controller output to a pressure gauge (open-loop conditions must exist). Do not apply supply pressure at this time.

Note

4195KB and KC controllers with anti-reset windup (suffix letter F) are supplied with two O-rings (key 52), valve cover (key 51), and two machine screws (key 53). Use these parts in the next step.

1. For controllers with anti-reset windup (suffix letter F), record the direction of the arrow on the anti-reset windup relief valve (key 55). Remove the relief valve and install the two O-rings (key 52) and valve cover (key 51) supplied with the controller. Secure the valve cover with the two machine screws (key 53) provided.
2. If necessary, remove the two machine screws (key 6) and lift off the proportional band indicator cover (key 36).
3. If the controller has the external feedback option (available with the 4195KB only), connect the controller output to the external feedback connection. See figure 2-5 for the location of the output and external feedback connections.
4. Provide regulated supply pressure to the controller. Do not exceed the normal operating pressure in table 1-6.
5. For a controller with manual set point, move the set point indicator to the mid-scale mark on the process scale. For a controller with remote set point (suffix letter M), adjust the remote set point pressure until the set point indicator is at the mid-scale mark on the process scale.
6. Set the reset adjustment to 0.01 minutes per repeat.
7. If the controller has rate (4195KC controllers), turn the rate adjustment to OFF.
8. Apply process pressure equal to the mid-scale value of the process scale span. If pressure is not available to pressure the input element to mid-scale value, an alternate method is to disconnect link number 1 at the input element and tape the process pointer at mid-scale mark on the process scale. If the controller has a capsular input element, note the hole where link number 1 is connected to the input element, then disconnect link 1. This method should only be used if pressure is not available to pressure the input element to the mid-scale value.

Note

Because of the high controller gain, the controller output will not remain stable in steps 9 through 13. The controller output gauge is adequate to check the output pressure during this procedure.

9. Set the proportional band between DIRECT and REVERSE.
10. The controller output should be relatively stable at any value within the output range. If not, adjust flapper leveling screw 2 (the screw nearest the nozzle) until the output is relatively stable.
11. Set the proportional band to 30 percent DIRECT. The controller output should be relatively stable at any value within the output range. If not, adjust flapper leveling screw 3 (the screw nearest the nozzle) until the output is relatively stable.
12. Set the proportional band to 30 percent REVERSE. The controller output should be relatively stable at any value within the output range. If not, adjust flapper leveling screw 1 (the screw nearest the nozzle) until the output is relatively stable.
13. Repeat steps 9 through 12 until the controller output remains relatively stable without further flapper leveling screw adjustment.

Note

Steps 14 through 20 check the flapper alignment.

14. Set the proportional band to 30 percent DIRECT.
15. Apply process pressure to the input element or, if link 1 was disconnected, remove the tape from the process pointer and move the pointer until it aligns with the right-hand edge of the set point indicator as shown in figure 4-4.

The controller output should be within 0.14 bar (2 psig) of the supply pressure.

Figure 4-4. Alignment of the Process Pointer with the Set Point Indicator

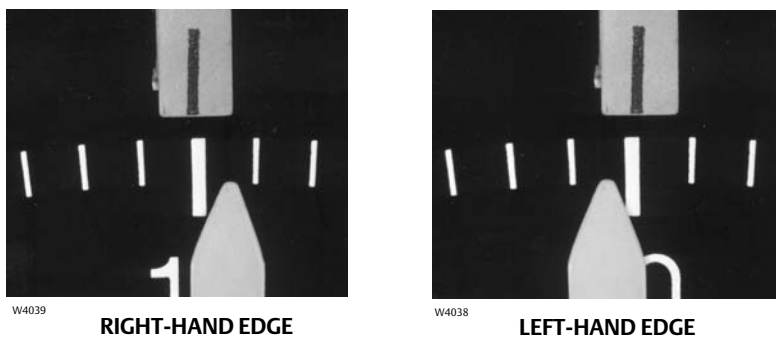

16. Apply process pressure to the input element or, if disconnected, move the process pointer until it aligns with the left-hand edge of the set point indicator as shown in figure 4-4.

The controller output pressure should go to 0 bar (0 psig).

17. Set the proportional band to 30 percent REVERSE.
18. Apply process pressure to the input element or, if disconnected, move the process pointer until it aligns with the right-hand edge of the set point indicator as shown in figure 4-4. The controller output should be 0 bar (0 psig).
19. Apply process pressure to the input element or, if disconnected, move the process pointer until it aligns with the left-hand edge of the set point indicator as shown in figure 4-4. The controller output should be within 0.14 bar (2 psig) of the supply pressure.
20. If the controller does not perform as indicated in steps 14 through 19, the flapper is not correctly aligned. This may occur because the output was not sufficiently stabilized in steps 9 through 13. Repeat steps 8 through 19.

21. When the flapper is correctly aligned, set the proportional band to 400 percent in the desired controller action and replace the proportional band indicator cover. If link 1 was disconnected, reconnect link 1 to the input element using the same hole noted in step 8.
22. Remove supply pressure.
23. If the controller has the external feedback option, disconnect the outside tubing which connects the external feedback connection to the output connection.
24. For controllers with anti-reset windup (suffix letter F), remove the two machine screws, valve cover and two O-rings installed in step 1 of this procedure. Install the anti-reset windup relief valve (key 55) with the arrow pointing in the direction recorded in step 1.

Anti-Reset Windup (suffix letter F) Differential Relief Valve Calibration

Calibration for the differential relief valve to relieve on rising controller output pressure

1. Provide a means of measuring the controller output pressure by connecting the controller output to a pressure gauge (open-loop conditions must exist). Do not apply supply pressure at this time.
2. Set the reset adjustment to 0.01 minutes per repeat (wide open) and the rate adjustment (4195KC controllers only) to the OFF position.
3. For a controller with manual set point, move the set point indicator to the mid-scale mark on the process scale. For a controller with remote set point, adjust the remote set point pressure until the set point indicator is at the mid-scale mark on the process scale.
4. Set the proportional band to 100 percent in either the DIRECT or REVERSE action depending on the application requirements.
5. Refer to figure 4-3 for the location of the anti-reset windup differential relief valve. For the differential relief valve to relieve on rising controller output pressure, install the valve so the arrow on the valve points down. To change the direction of the arrow, loosen the two mounting screws, pull the valve out, and reinstall the valve with the arrow pointing down. Tighten the two mounting screws.
6. Provide a regulated supply pressure to the controller. Do not exceed the normal operating pressure in table 1-6.

Note

Because of the high controller gain with the reset adjustment at 0.01 minutes per repeat, the controller output will not balance perfectly in the following step. If the controller output is stable for approximately 5 seconds, it is adequately balanced.

7. Increase the process pressure (or vacuum for a vacuum controller) to the controller until the controller output pressure balances at 0.4 bar (6 psig) for a 0.2 to 1.0 bar (3 to 15 psig) output range or 0.8 bar (12 psig) for a 0.4 to 2.0 bar (6 to 30 psig) output range.
8. Turn the reset adjustment to the CLOSED (4195KB controllers) or OFF (4195KC controllers) position.
9. Increase the controller output pressure in small steps [approximately 0.04 bar (0.5 psig)] by changing the process pressure to the controller or by changing the controller set point. After each change in process pressure or set point, the controller output pressure should quickly change and then stabilize at the new value.
10. Continue to change the controller output pressure in 0.04 bar (0.5 psi) steps and check the output pressure after each step to make sure it stabilizes. At some point, the controller output will start to ramp upward to supply pressure with no further change to the controller input or set point. Record the controller output pressure where this ramping action begins because this is the point at which the differential relief valve has relieved.
11. To obtain the differential relief valve differential setting, calculate the difference between the original controller output pressure in step 7 and the controller output pressure recorded in step 10.
12. If the differential pressure calculated in step 11 is incorrect for the application, adjust the differential pressure by turning the differential relief valve adjustment screw shown in figure 4-3. Turn the screw clockwise to decrease the

differential pressure or counterclockwise to increase the differential pressure. The differential relief valve is set at the factory to relieve at approximately 0.4 bar (5 psi) differential pressure.

13. Repeat steps 7 through 12 until the required differential pressure is obtained.

Calibration for the differential relief valve to relieve on falling controller output pressure

1. Provide a means of measuring the controller output pressure by connecting the controller output to a pressure gauge (open-loop conditions must exist). Do not apply supply pressure at this time.
2. Set the reset adjustment to 0.01 minutes per repeat (wide open) and the rate adjustment (4195KC controllers only) to the OFF position.
3. For a controller with manual set point, move the set point indicator to the mid-scale mark on the process scale. For a controller with remote set point, adjust the remote set point pressure until the set point indicator is at the mid-scale mark on the process scale.
4. Set the proportional band to 100 percent in either the DIRECT or REVERSE action depending on the application requirements.
5. Refer to figure 4-3 for the location of the anti-reset windup differential relief valve. For the differential relief valve to relieve on falling controller output pressure, install the valve so the arrow on the valve points up. To change the direction of the arrow, loosen the two mounting screws, pull the valve out, and reinstall the valve with the arrow pointing up. Tighten the two mounting screws.
6. Provide a regulated supply pressure to the controller. Do not exceed the normal operating pressure in table 1-6.

Note

Because of the high controller gain with the reset adjustment at 0.01 minutes per repeat, the controller output will not balance perfectly in the following step. If the controller output is stable for approximately 5 seconds, it is adequately balanced.

7. Increase the process pressure (or vacuum for a vacuum controller) to the controller until the controller output pressure balances at 0.8 bar (12 psig) for a 0.2 to 1.0 bar (3 to 15 psig) output range or 1.6 bar (24 psig) for a 0.4 to 2.0 bar (6 to 30 psig) output range.
8. Turn the reset adjustment to the CLOSED (4195KB controllers) or OFF (4195KC controllers) position.
9. Decrease the controller output pressure in small steps [approximately 0.04 bar (0.5 psig)] by changing the process pressure to the controller or by changing the controller set point. After each change in controller process pressure or set point, the controller output pressure should quickly change and then stabilize at the new value.
10. Continue to change the controller output pressure in 0.04 bar (0.5 psi) steps and check the output pressure after each step to make sure it stabilizes. At some point, the controller output will start to ramp downward to 0 bar (0 psig) with no further change to the controller input or set point. Record the controller output pressure where this ramping action begins because this is the point at which the differential relief valve has relieved.
11. To obtain the differential relief valve differential setting, calculate the difference between the original controller output pressure in step 7 and the controller output pressure recorded in step 10.
12. If the differential pressure calculated in step 11 is incorrect for the application, adjust the differential pressure by turning the differential relief valve adjustment screw, shown in figure 4-3. Turn the screw clockwise to decrease the differential pressure or counterclockwise to increase the differential pressure. The differential relief valve is set at the factory to relieve at approximately 0.4 bar (5 psi) differential pressure.
13. Repeat steps 7 through 12 until the required differential pressure is obtained.

Principle of Operation for 4195KB and KC Controllers

Overall Operation

Refer to the schematic diagram in figure 4-5 for 4195KB controllers, or to the schematic diagram in figure 4-6 for 4195KC controllers.

The input element is connected to the process pointer and to the flapper by connecting links. As the process pressure increases (in a direct-acting controller), the flapper moves toward the nozzle, restricting flow through the nozzle and increasing nozzle pressure. When this occurs, relay action increases the output pressure (delivery) of the controller. Output pressure is fed back to the proportional bellows and to the reset bellows. The action of the proportional bellows quickly counteracts the flapper movement that resulted from the process pressure change and backs the flapper away from the nozzle.

Figure 4-5. Fisher 4195KB Controller Schematic

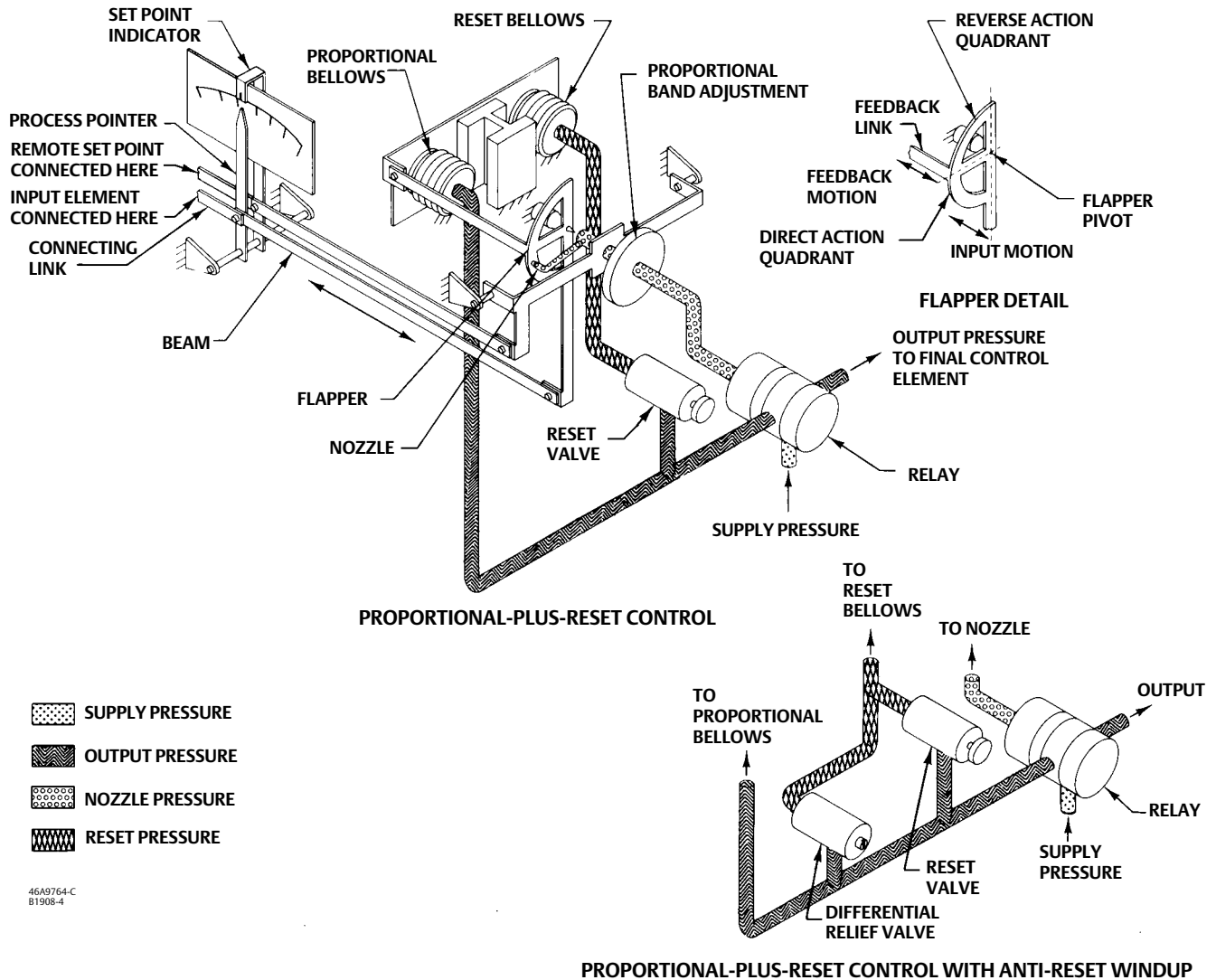

46A9764-C
B1908-4

Pressure in the reset bellows opposes the action of the proportional bellows and slowly moves the flapper closer to the nozzle. The result of this interaction is that, when the process pressure changes, proportional action temporarily reduces the gain of the controller for improved stability. The process pressure then slowly returns to set point, as pressure in both bellows equalizes via the reset action.

Moving the set point indicator changes the distance between the nozzle and flapper as does a change in process pressure, except that when the set point is changed, the nozzle moves with respect to the flapper.

Figure 4-6. Fisher 4195KC Controller Schematic

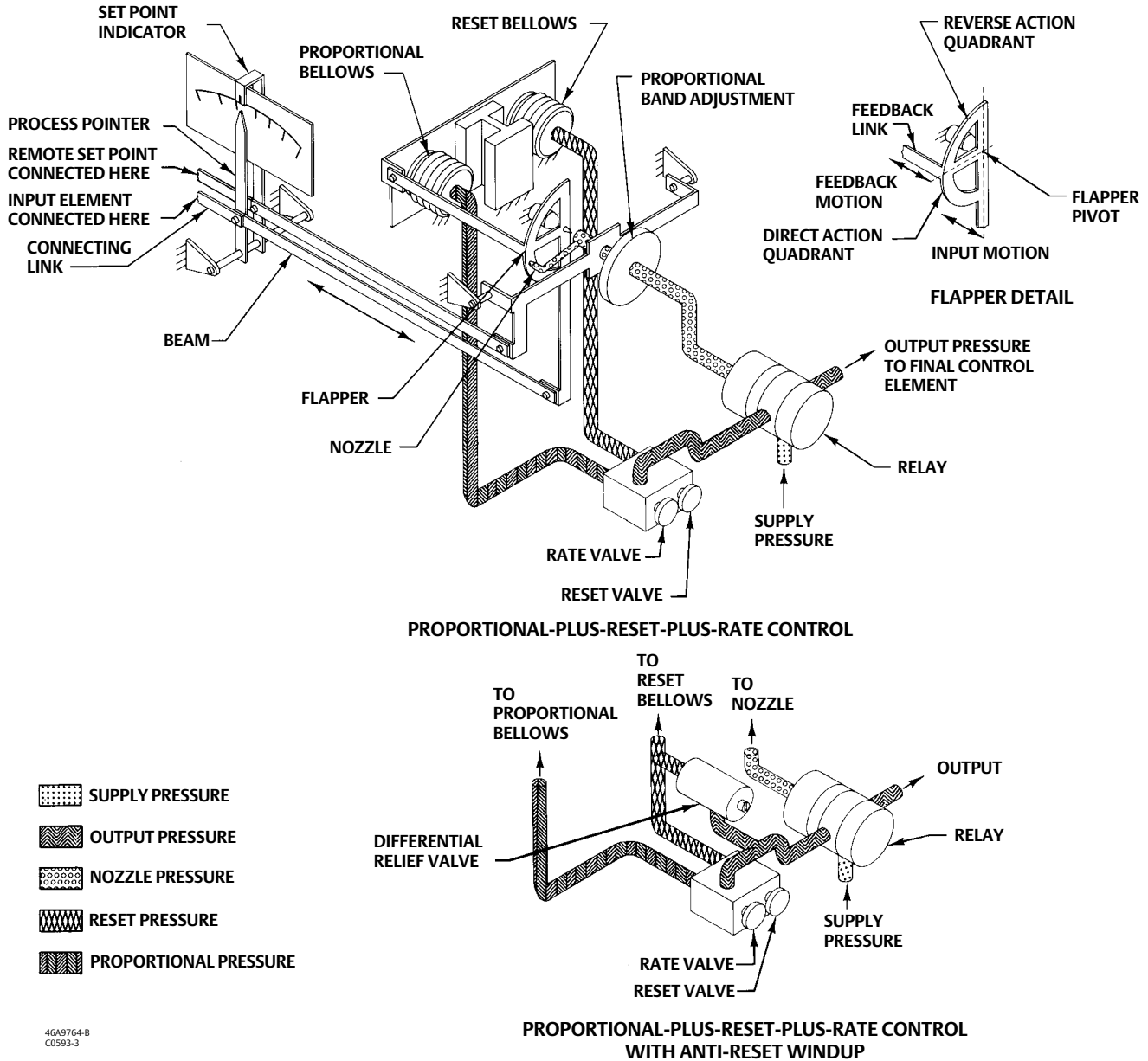

46A9764-B
C0593-3

The proportional band adjustment positions the nozzle on the flapper. Increasing (widening) the proportional band moves the nozzle to a position on the flapper where less input and more feedback motion occurs, which decreases the gain of the controller. Decreasing (narrowing) the proportional band moves the nozzle toward a position where more input and less feedback motion occurs, which increases the gain. The controller is changed from direct to reverse by turning the proportional band adjustment to position the nozzle on the flapper quadrant to a point where the direction of the flapper motion versus input motion is reversed as shown in the flapper detail of figure 4-5 or 4-6. With the controller in the reverse-acting mode, an increase in process pressure causes a decrease in output pressure.

A 4195KC controller also has a rate valve as shown in figures 4-6 and 4-7. This valve is an adjustable restriction that momentarily increases the controller gain to accelerate the corrective action for slow pressure systems. A proportional-plus-reset-plus-rate controller responds to a change in process pressure as follows:

- First, the rate action delays the proportional action just long enough to allow the controller to respond to the change quickly with high gain, but not long enough for the high gain to cause instability.
- Then, the low gain provided by the proportional action keeps the system stable. Finally, reset action slowly increases the gain and returns the process pressure toward the set point.

Figure 4-7. Reset-Rate Schematic

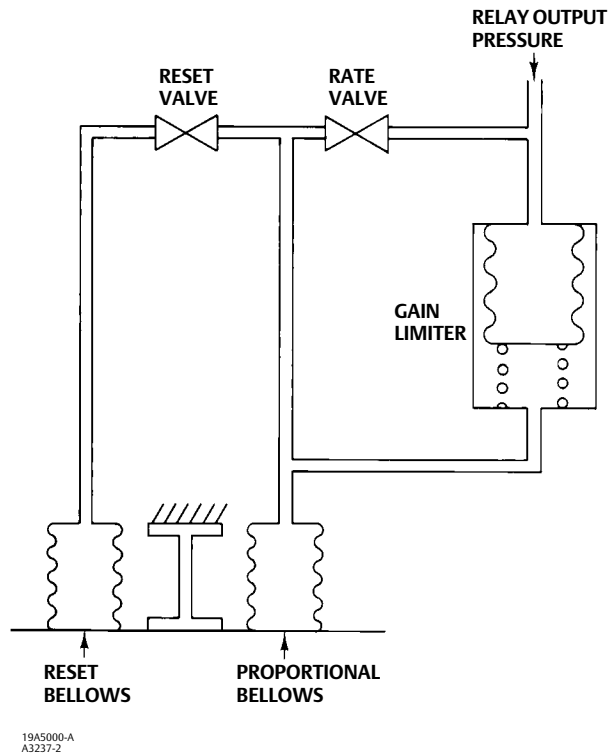

Anti-Reset Windup (suffix letter F) Operation

Anti-reset windup is available on all 4195KB and KC controllers and is designated by the letter F in the type number. The differential relief valve operates when the difference between the proportional bellows pressure and the reset bellows pressure reaches a predetermined value. Anti-reset windup reduces overshoot of the process pressure that can result from a large or prolonged deviation from set point.

Remote Set Point (suffix letter M) Operation

The capability to adjust the controller set point from a remote location is available with all 4195KB and KC controllers. This option is designated by the letter M in the type number.

A control pressure is applied to the capsular element within the remote set point assembly. The expansion and contraction of the capsule moves the set point indicator via connecting linkage. Increasing the control pressure to the capsule increases the set point setting and decreasing the control pressure reduces the set point setting.

Auto/Manual Station (suffix letter E) Operation

A controller with the auto/manual station (designated by the suffix letter E in the type number) has piping on the output side of the relay as shown in figure 4-8. Supply pressure to the relay is also applied to the manual loader. The manual loader, functioning as a regulator, applies pressure to one side of the plastic tube and to the auto/manual switch. Output pressure from the relay registers on the other side of the plastic tube as well as in the auto/manual switch.

Figure 4-8. Fisher 4195KB and KC Auto/Manual Station Schematic

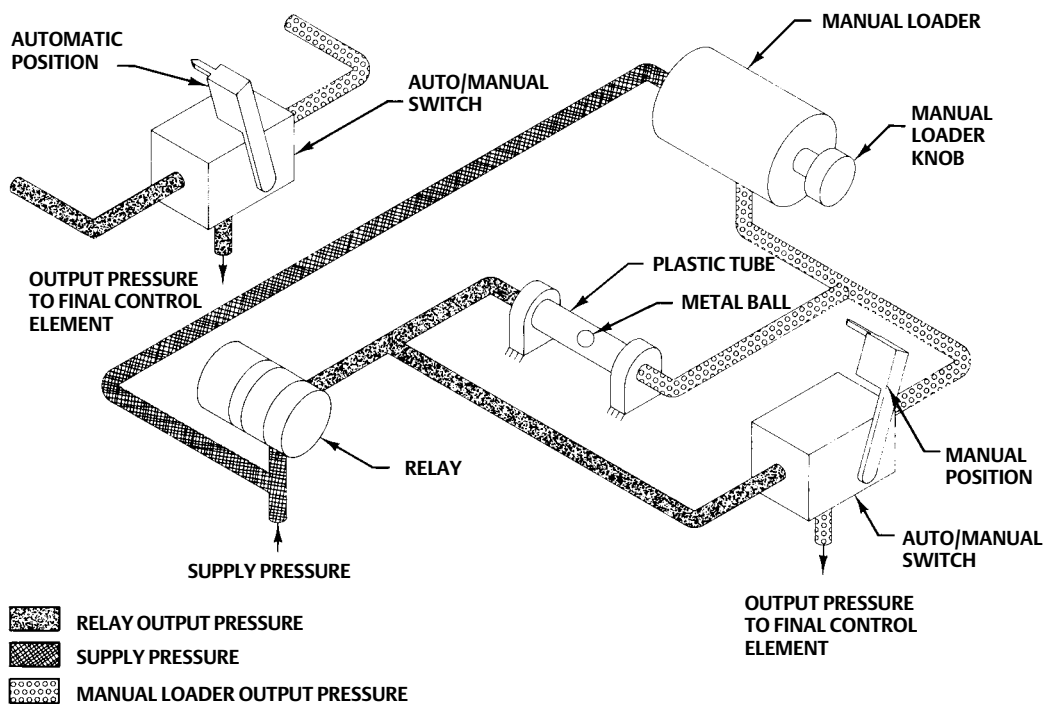

48A5230-A
A2999-1

When the auto/manual switch is in the MANUAL position, the manual loader output is channeled through the auto/manual switch and becomes the controller output. When the auto/manual switch is in the AUTO position, the relay output is channeled through the switch to become the controller output.

Before the auto/manual switch is operated, the relay output must equal the manual loader output to avoid bumping the process. Adjusting the set point varies the pressure on the left-hand side of the plastic tube. Adjusting the manual loader knob varies the pressure on the right-hand side. When the pressures are equal, the metal ball is centered in the tube and it is held in place by a small magnet. A pressure imbalance forces the ball to one end of the tube where it forms a seal, blocking air flow through the tube.

External Feedback Operation

External feedback is available for all 4195KB controllers. Controllers with this option have an external connection on the bottom of the controller case as shown in figure 2-5. This connection breaks the positive feedback (reset) loop inside the controller and brings it outside as shown in figure 4-9. The connection allows the positive feedback loops of two controllers (primary and secondary) to be tied together when the controllers are used in an override application. When connected, the secondary controller tracks the primary controller, minimizing reset windup.

Figure 4-9. Schematic of External Feedback Option

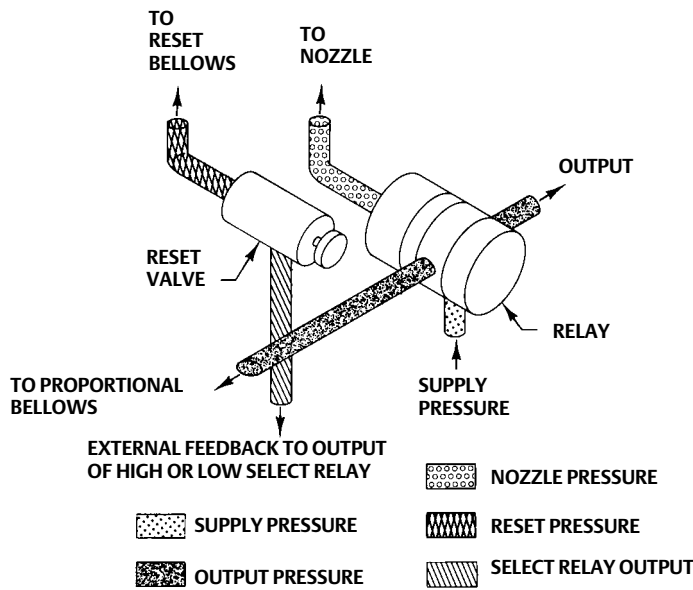

47A0975-A
A3342-1

Section 5 4195KS Differential Gap Controllers

Operating Information

This section includes descriptions of adjustments and procedures for prestartup and startup. Location of adjustments is shown in figures 5-1 and 5-2. To better understand the adjustments and overall operation of the controller, refer to the Principle of Operation section and the schematic diagrams, figures 5-4 and 5-5.

Note

Some of the following procedures require that the proportional band knob be adjusted to between DIRECT and REVERSE. If this is done, it will be necessary to set the proportional band knob to 400 (direct or reverse action) before replacing the proportional band indicator cover.

Figure 5-1. Fisher 4195KS Controller Parts and Adjustments Locations

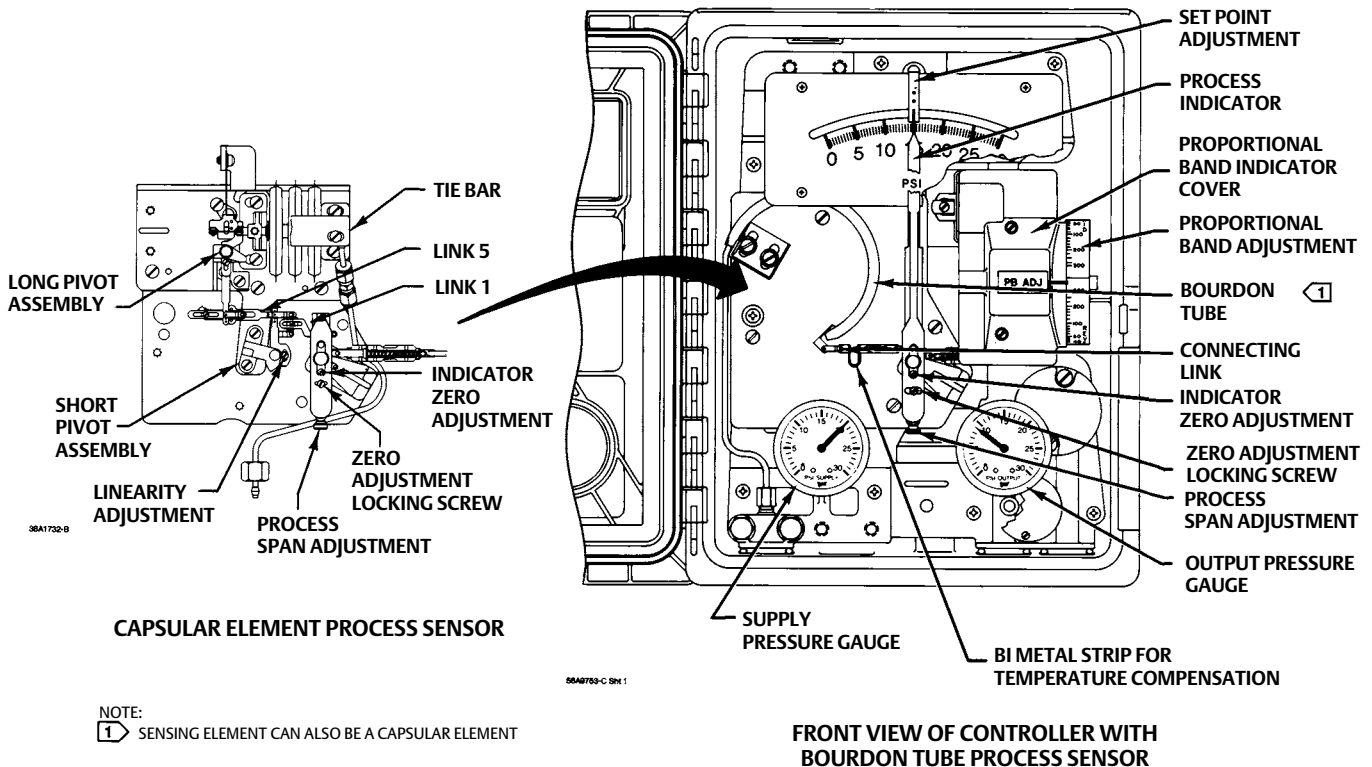

C0528-1

Figure 5-1. Fisher 4195KS Controller Parts and Adjustments Locations (continued)

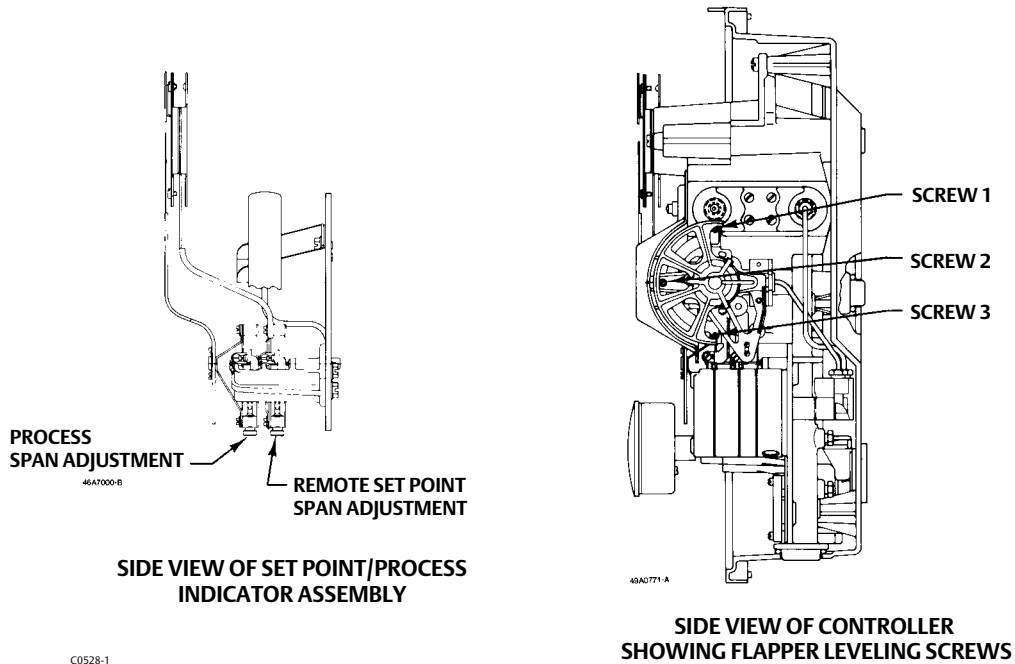

Adjustments for 4195KS Controllers

Manual Set Point

The set point adjustment adjusts the upper or lower switching point, depending on controller action. To adjust the set point, open the controller cover, and move the set point adjustment until the pointer indicates the desired value of pressure on the process pressure scale. Move the adjustment to the right to increase the set point, and to the left to decrease it. Adjusting the set point does not affect the differential gap setting.

Remote Set Point (Option M)

CAUTION

Do not move the set point manually on controllers with remote set point. Doing so could damage the controller.

If the controller is equipped with remote set point option, vary the remote set point pressure to change the set point. Increase the pressure to increase the set point, and decrease the pressure to decrease the set point.

Proportional Band (Differential Gap)

The proportional band knob adjusts width of the gap between switching points. Rotate the knob until the desired value is opposite the line on the proportional band indicator cover.

Changing Controller Action

Controller action can be switched from direct to reverse or vice versa by loosening the screws on the proportional band indicator cover and moving the cover out so the proportional band knob can be rotated to the desired action.

The white portion of the adjustment enables direct controller action; the black portion enables reverse controller action.

Auto/Manual Switching (Option E)

Refer to figure 5-5 if the controller has the auto/manual option. Two balance methods are available to equalize the manual output with the controller pressure. To switch from automatic to manual mode, carefully adjust the loader knob until the metal ball inside the plastic tube moves into the switching zone. Then move the automatic/manual switch to MANUAL. Turn the loader knob clockwise to increase the controller output or counter clockwise to decrease it. To switch from manual to automatic mode, adjust the set point manually or with remote set point pressure to move the ball into the switching zone. Turn the switch to AUTOMATIC, and adjust the set point manually or with the remote set point pressure to control the output.

When the automatic/manual switch is in AUTOMATIC, adjusting the loader knob has no effect on the controller output. When the automatic/manual switch is in MANUAL, changing the set point adjustment has no effect on the controller output.

Note

Switching the controller between automatic and manual, or manual and automatic mode, without balancing the outputs, can disturb the process and cause controller cycling.

Prestartup Checks for 4195KS Controllers

When performing the checks, open loop conditions must exist. Refer to figure 5-1 for location of adjustments.

Note

If the controller has the auto/manual option (option E), be sure the controller is in the automatic mode prior to performing prestartup checks.

1. Connect supply pressure to the supply pressure regulator, and be sure it is delivering the proper supply pressure to the controller. Provide a means of measuring the controller output pressure.
2. For controllers with remote set point (option M), connect regulated pressure of 0.2 to 1.0 bar (3 to 15 psig) or 0.4 to 2.1 bar (6 to 30 psig) to the remote set point connection at the top of the controller case.
3. Loosen two screws (key 6), lift off the proportional band cover (key 36), and set the proportional band knob between DIRECT and REVERSE.
4. The process indicator should indicate the process pressure. For example, with the process pressure at 50 percent of the input span, the process pointer should be 50 percent (+/-1 percent) of its span. Slight adjustment of the indicator zero screw may be necessary. See figure 5-1 for zero adjustment and locking screw location.
5. If desired, the accuracy can be verified at other points on the scale. If the indicator appears to be out of calibration, refer to the process zero and span adjustment portion of the calibration procedure.
6. Install the proportional band cover and install two screws (key 6).

Startup for 4195KS Controllers

It is recommended that the controller switching points be set as described in the calibration procedures.

If they are used, slowly open the upstream and downstream manual control valves in the pipeline and close the manual bypass valve.

Calibration of 4195KS Controllers

Note

Some of the following procedures require that the proportional band knob be adjusted to between DIRECT and REVERSE. If this is done, it will be necessary to set the proportional band knob to 400 (direct or reverse action) before replacing the proportional band indicator cover.

If the prestartup checks revealed faulty adjustment of the process indicator, perform the calibration procedures. These procedures are valid for either shop or field calibration, provided that open process loop conditions exist.

Note

If the controller has the auto/manual option, be sure the controller is in the automatic mode prior to performing the calibration procedures.

Process Zero and Span Adjustment

Note

Any adjustment of the pointer span adjustment screw will require readjustment of the pointer zero adjustment screw.

1. Refer to figure 5-1 for location of adjustments.
2. Remove the two screws (key 6) and lift off the proportional band indicator cover (key 36).
3. Set the proportional band between DIRECT and REVERSE.
4. Adjust the process pressure to the low limit of the input range.
5. Adjust the process pointer to the lowest limit of the input scale by loosening the zero adjustment locking screw and turning the zero adjustment screw.
6. Adjust the process pressure to the upper limit of the input span. Note whether the pointer indication is above or below the upper limit of the process scale.
7. Adjust the span screw as follows: Clockwise to increase span for a low indication; counterclockwise to decrease span for a high indication. Adjust the span screw to correct one-half the error.
8. Repeat steps 4 through 7 until the error is eliminated.
9. Install the proportional band indicator cover (key 36), and tighten the two4 screws (key 6).

Remote Set Point Zero and Span Adjustment (Option M)

Note

Any adjustment of the pointer span adjustment screw will require readjustment of the pointer zero adjustment screw.

1. Refer to figures 5-1 and 5-2 for location of adjustments.
2. Remove the two screws (key 6) and lift off the proportional band indicator cover (key 36).
3. Set the proportional band between DIRECT and REVERSE.
4. Adjust the process pressure to the low limit of the input range.
5. Adjust the process pointer to the lowest limit of the input scale by loosening the zero adjustment locking screw and turning the zero adjustment screw.
6. Adjust the process pressure to the upper limit of the input span. Note whether the pointer indication is above or below the upper limit of the process scale.
7. Adjust the span screw as follows: Clockwise to increase span for a low indication; counterclockwise to decrease span for a high indication. Adjust the span screw to correct one-half the error.
8. Repeat steps 4 through 7 until the error is eliminated.
9. Install the proportional band indicator cover (key 36), and tighten the two screws (key 6).

Figure 5-2. Fisher 4195KS Controller Parts and Adjustments Locations (Remote Set Point Option)

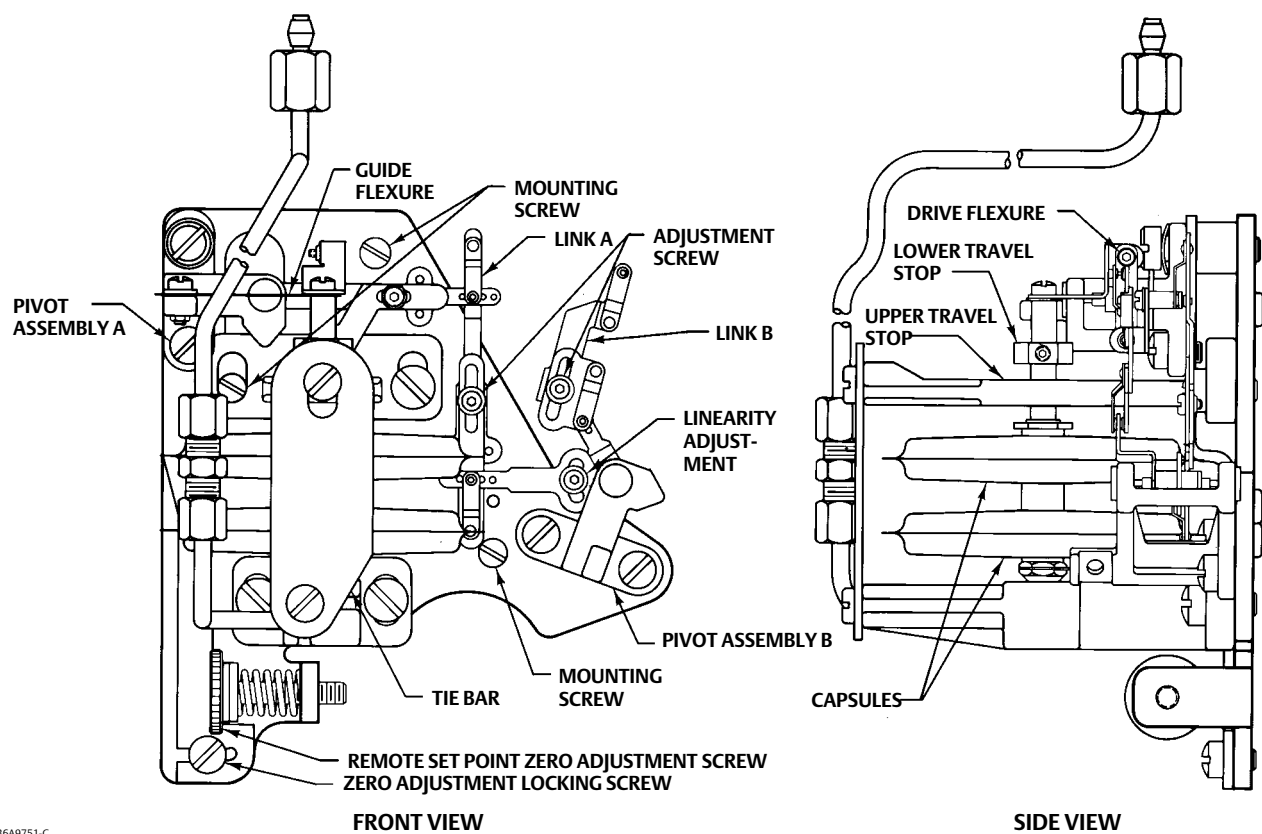

36A9751-C
B1668-4

Setting Switching Points

Direct-Acting Controllers

The controller output signal will switch from zero pressure to full supply pressure when increasing process pressure passes the upper switching point.

The controller output signal will not return to zero pressure until decreasing process pressure passes the lower switching point. When making adjustments as described in the following steps, keep in mind that:

- Changing the set point adjustment will move both switching points equally in the direction of adjustment.
- Changing the proportional band adjustment will widen or narrow the differential gap between the two switching points by moving the position of the lower switching point.

Figure 5-3 shows the relationship between the percent of sensor range between switching points and the proportional band setting on the controller. The following example illustrates how to use figure 5-3.

Example: The sensing element has a range of 30 psi. The lower switching point is to be set at 10 psi and the upper switching point is to be set at 25 psi.

Proceed as follows:

- Divide the differential gap (the difference between the upper and lower switching points) by the sensing element range. Multiply the result by 100 as shown in the following equation.

$$\frac{\text{Differential Gap}}{\text{Sensing Element Range}} \times 100 = \frac{15 \text{ psi}}{30 \text{ psi}} \times 100 = 50\%$$

- Locate the 50 percent line on figure 5-3. Move along this line until you intersect the curve. Read the proportional band setting on the left hand axis. For this example, the setting is approximately 35 percent.
1. Using the curve in figure 5-3, determine the correct proportional band setting for the desired gap (expressed as a percent of the input span) between the switching points.
 2. Set the proportional band knob to the desired setting determined in step 1.
 3. Adjust the set point to the desired upper switching point.
 4. Increase the process pressure until the controller output signal switches from zero pressure to full supply pressure.
 5. Decrease the process pressure to the desired switching point at which the controller output signal switches from full supply pressure to zero pressure.
 6. Narrow or widen the proportional band slowly until the output signal switches from full supply pressure to zero pressure.
 7. Repeat steps 4 through 6 until the controller output switches at the desired points.

Figure 5-3. Curve for Determining Proportional Band Setting

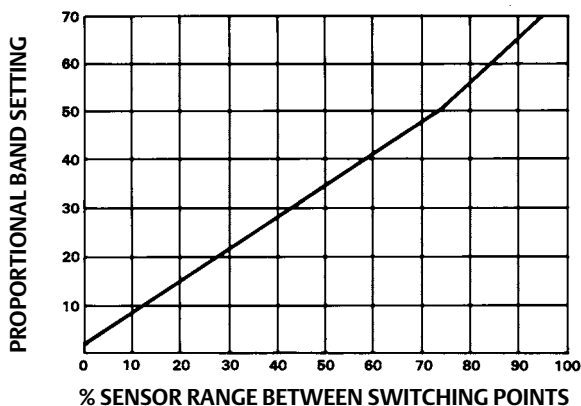

A2853-1

8. Observe the process pointer when the output switches at the upper switching point. The process pointer indication should be within ± 2 percent of the set point indication.

Reverse-Acting Controllers

The controller output signal will switch from zero pressure to full supply pressure when decreasing process pressure passes the lower switching point.

The controller output signal will not return to zero pressure until increasing process pressure passes the upper switching point. When making adjustments as described in the following steps, keep in mind that:

- Changing the set point adjustment will move both switching points equally in the direction of adjustment.
- Changing the proportional band adjustment will widen or narrow the differential gap between the two switching points by moving the position of the lower switching point.

Figure 5-3 shows the relationship between the percent of sensor range between switching points and the proportional band setting on the controller. The following example illustrates how to use figure 5-3.

Example: The sensing element has a range of 30 psi. The lower switching point is to be set at 10 psi and the upper switching point is to be set at 25 psi.

Proceed as follows:

- Divide the differential gap (the difference between the upper and lower switching points) by the sensing element range. Multiply the result by 100 as shown in the following equation.
- Locate the 50 percent line on figure 5-3. Move along this line until you intersect the curve. Read the proportional band setting on the left hand axis. For this example, the setting is approximately 35 percent.

$$\frac{\text{Differential Gap}}{\text{Sensing Element Range}} \times 100 = \frac{15 \text{ psi}}{30 \text{ psi}} \times 100 = 50\%$$

1. Using the curve in figure 5-3, determine the correct proportional band setting for the desired gap (expressed as a percent of the maximum input element span) between the switching points.
2. Set the proportional band knob to the desired setting determined in step 1.
3. Adjust the set point to the desired lower switching point.
4. Decrease the process pressure until the controller output signal switches from zero pressure to full supply pressure.
5. Increase the process pressure to the desired switching point at which the controller output signal switches from full supply pressure to zero pressure.
6. Narrow or widen the proportional band slowly until the output signal switches from full supply pressure to zero pressure.
7. Repeat steps 4 through 6 until the controller output switches at the desired points.
8. Observe the process pointer when the output switches at the upper switching point. The process pointer indication should be within ± 2 percent of the set point indication.

Principle of Operation

Overall Operation

Refer to the schematic diagram in figure 5-4.

The input element is connected to the process pointer and to the flapper by connecting links. As the process pressure increases (in a direct-acting controller). This movement restricts the flow through the nozzle and increases nozzle pressure. When this occurs, relay action increases the output pressure (delivery) of the controller. Output pressure is fed back to the positive feedback bellows. The action of this bellows is a positive feedback action that moves the flapper closer to the nozzle, increasing nozzle pressure, which in turn, increases the relay output. Output pressure to the final control element switches to full supply pressure.

Figure 5-4. Fisher 4195KS Controller Schematic

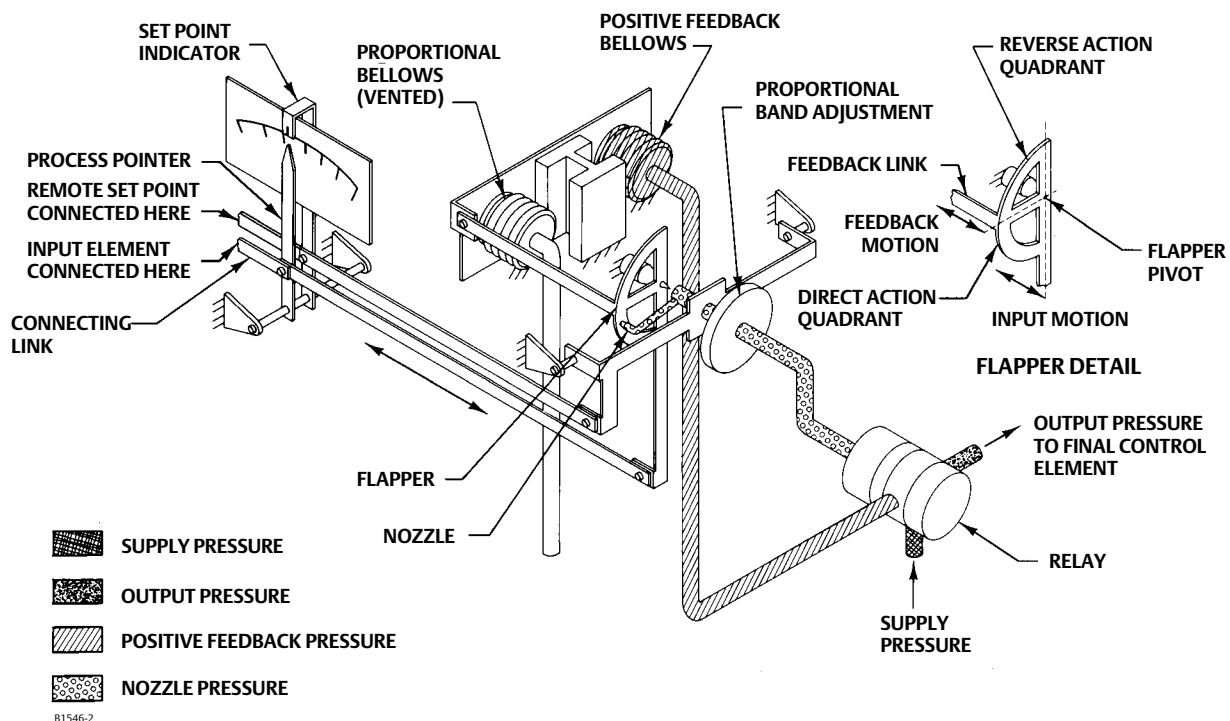

As the process pressure decreases, approaching the lower switching point, the flapper moves away from the nozzle (in a direct-acting controller) reducing nozzle pressure. Through relay action, pressure to the positive feedback bellows is reduced, moving the flapper further away from the nozzle, and further reducing nozzle pressure. Output pressure to the final control element switches to zero.

The set point adjustment changes the proximity of the nozzle and flapper as does a change in process pressure except that, when the set point is changed, the nozzle moves with respect to the flapper. The set point adjustment moves both the upper and lower switching points.

The proportional band knob positions the nozzle on the flapper. Increasing (widening) the proportional band moves the nozzle away from the input connection. When the proportional band adjustment moves the nozzle across the feedback connection, the controller action changes between direct and reverse. On a direct-acting controller, changing the proportional band adjustment will widen or narrow the differential gap between the two switching points. This is accomplished by moving the position of the lower switching point. On a reverse-acting controller, changing the proportional band adjustment will widen or narrow the differential gap between the two switching points by moving the position of the upper switching point.

Remote Set Point (Option M)

The capability to adjust the controller set point from a remote location is available with all 4195KS controllers. This option is designated by the letter M in the type number.

Auto/Manual Option

Controllers with the auto/manual option (designated by the letter E in the type number) have piping on the output side of the relay as shown in figure 5-5. Supply pressure to the relay is also applied to the manual loader. The manual loader, functioning as a regulator, applies pressure to one side of the plastic tube and to the auto/manual switch. Output pressure from the relay registers on the other side of the plastic tube as well as in the auto/manual switch.

When the auto/manual switch is in the MANUAL position, the manual loader output is channeled through the auto/manual switch and becomes the output of the controller. When the auto/manual switch is in the AUTO position, the relay output is channeled through the switch to become the output of the controller.

Before the auto/manual switch is operated, the relay output must equal the manual loader output to avoid bumping the process. Adjusting the set point varies the pressure on the left-hand side of the plastic tube. Adjusting the manual loader knob varies the pressure on the right-hand side. When the pressures are equal, the metal ball is centered in the tube. Pressure imbalance forces the ball to one end of the tube where it forms a seal, blocking air flow through the tube.

Figure 5-5. Fisher 4195KS Auto/Manual Schematic

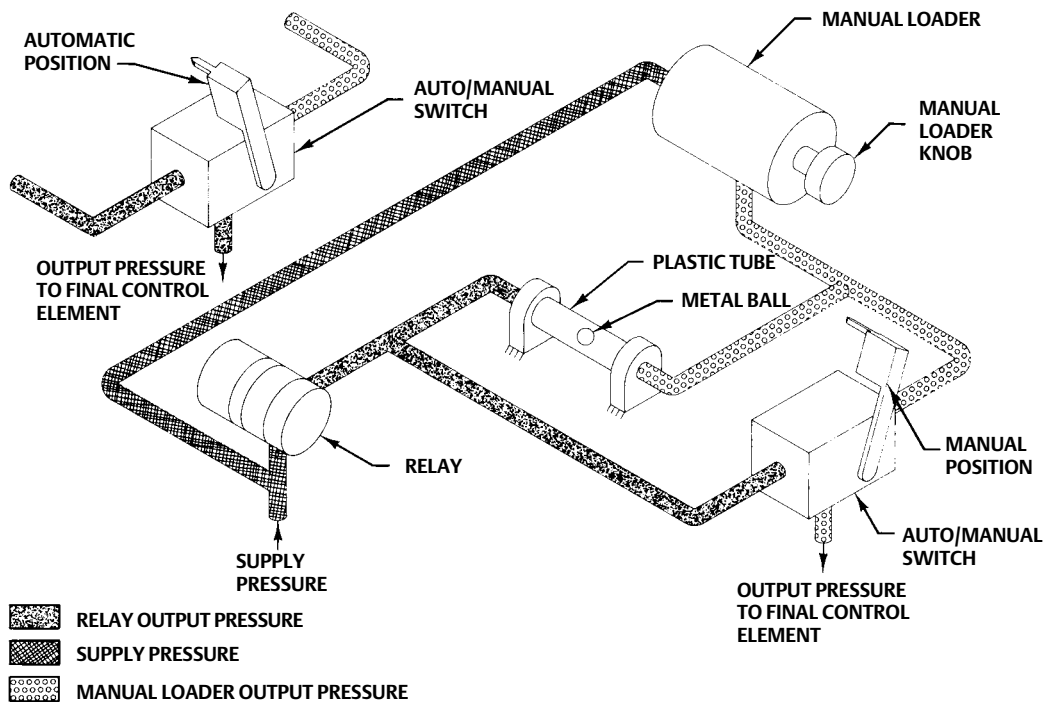

48A5230-A
A2999-1

Section 6 Maintenance

Controller parts are subject to normal wear and must be inspected and replaced as necessary. The frequency of inspection and parts replacement depends upon the severity of the service conditions. When inspection or repairs are required, disassemble only those parts necessary to accomplish the job.

Inspection and Maintenance

⚠ WARNING

The following maintenance procedures require taking the controller out of service. To avoid personal injury and property damage caused by uncontrolled process pressure, observe the following before performing any maintenance procedures:

Before performing any maintenance operations:

- Always wear protective clothing, gloves, and eyewear.
- Provide some temporary means of control for the process before taking the controller out of service.
- Shut off the supply pressure to the controller.
- Personal injury or property damage may result from fire or explosion if natural gas is used as the supply pressure medium and preventive measures are not taken. Preventive measures may include, but are not limited to, one or more of the following: Remote venting of the unit, re-evaluation the hazardous area classification, ensuring adequate ventilation, and the removal of any ignition sources. For information on remote venting of this controller, refer to page 14.
- Disconnect any operating lines providing supply air pressure, a process input signal, or other pressure source to the controller.
- Check with your process or safety engineer for any additional measures that must be taken to protect against process media.

Note

Unless otherwise noted, key numbers refer to figures 7-1 through 7-7. Figures 3-1 and 3-3 show adjustment locations for 4195KA controllers, figures 4-1 and 4-3 show adjustment locations for 4195KB and KC controllers, and figures 5-1 and 5-2 show adjustment locations for 4195KS controllers. For maintenance on the indicator assembly, refer to figures 7-2, 7-3 and 7-4.

Select the appropriate maintenance procedure and perform the numbered steps. Each procedure requires that the supply pressure be shut off before beginning maintenance.

The maintenance procedures section describes part replacement common to 4195KA, KB, KC, and KS controllers. After completing the maintenance procedures, perform the appropriate calibration procedures. Unless otherwise noted, calibration procedures for the 4195KA controller are in Section 3, calibration procedures for the 4195KB and KC controller are in Section 4, and calibration procedures for the 4195KS controller are in Section 5. If difficulty is encountered performing the calibration procedures in Section 3, 4, or 5 refer to the calibration procedures in this section.

Troubleshooting

As an aid to troubleshooting, table 6-1 lists some common operating faults, their probable cause, and suggests procedures for correcting the faults.

Table 6-1. Troubleshooting Chart

Fault	Possible Cause	Check	Correction
1. Process wanders or cycles about set point	1.1 Proportional band and reset settings 1.2 Supply pressure varying 1.3 Process pointer rubbing on cover or scale 1.4 Input element failure 1.5 Linkage failure 1.6 Relay malfunction 1.7 Anti-reset windup differential relief valve set too low (suffix letter F only)	1.1 Refer to the startup procedures for controller settings 1.2 Monitor the supply pressure with an external gauge. Ensure that it is set correctly and does not fluctuate. Note the number of instruments being supplied by the regulator 1.3 Note if the pointer is bent 1.4 Inspect the element for loose screws and damaged flexures, links or pivots. Using a soap solution, check the sensing element for leaks 1.5 Check for links that are bent or not connected properly, flexures bent or broken, pivots broken 1.6 By changing the process set point and observing the output verify that the output will change at about the same rate in both directions. 1.7 The minimum relief valve setting is dependent on the loop dynamics and the controller settings. If under normal load changes, the relief valve opens, instability can occur. Check by observing the controller reaction to a set point or load change under closed loop conditions	1.1 If stable control cannot be attained, and all other elements of the loop are functionally correct, examine other possible causes related to the controller 1.2 Correct as necessary. One regulator per instrument is recommended 1.3 Bend pointer to provide clearance 1.4 Repair or replace parts as necessary 1.5 Replace or repair as necessary 1.6 If the output changes quickly in one direction and sluggishly in the other, replace the relay 1.7 If the differential relief valve appears to be set too low, refer to the section of this instruction manual that covers the anti-reset windup option
2. Controlling off set point as reflected by process and set point indicators. Note: Some offset is inherent with proportional-only controllers (4195KA controllers). The amount of offset is a function of the proportional band setting	2.1 Supply pressure not set correctly 2.2 Flapper not aligned 2.3 Leak in input element/tubing assembly 2.4 Indicators out of calibration 2.5 Linkage not connected correctly 2.6 Leak in feedback system	2.1 Check with an external source 2.2 Refer to the flapper alignment procedure 2.3 Using soap solution, check the input element and tubing for leaks 2.4 Refer to the process indicator (and remote set if applicable) zero and span calibration procedures in this manual 2.5 Inspect for loose screws and damaged flexures, links or pivots 2.6 Open the reset valve to 0.1 minute/repeat. Adjust output pressure to 1.4 bar (20 psig). Using soap solution, check for leaks in the proportional and reset bellows in the tubing that connects these bellows	2.1 Reset the supply pressure if necessary. If the condition occurs again, the regulator should be rebuilt or replaced 2.2 Align the flapper as necessary 2.3 Repair or replace parts as necessary 2.4 Adjust as necessary 2.5 Repair or replace parts as necessary 2.6 Repair as necessary

(continued)

Table 6-1. Troubleshooting Chart (continued)

Fault	Possible Cause	Check	Correction
2. Controlling off set point as reflected by process and set point indicators. Note: Some offset is inherent with proportional-only controllers (4195KA controllers). The amount of offset is a function of the proportional band setting	2.7 Reset valve leaks	2.7 Hold the input constant and adjust the output to 1.0 bar (15 psig) for a 0.2 to 1.0 bar (3 to 15 psig) output or 2.0 bar (30 psig) for a 0.4 to 2.0 bar (6 to 30 psig) output. Close the reset valve. If the controller output varies as the reset valve is closed and no leaks were found in the rest of the feedback system (Step 2.6), the reset valve is leaking	2.7 Replace the reset valve (4195KB controllers) or the rate/reset valve (4195KC controllers)
	2.8 Leak in remote set point system	2.8 Adjust remote set point pressure to 1.0 bar (15 psig). Using soap solution, check for leaks in the remote set point and tubing assembly	2.8 Repair or replace parts as necessary
	2.9 Input element overpressured	2.9 Check for zero shift	2.9 Replace input element and adjust travel stops of applicable
3. Controlling off set point but not reflected by process and set point indicators	3.1 Controller is out of calibration	3.1 Refer to the process indicator, remote set point (if applicable), and flapper alignment procedures	3.1 Adjust as necessary
4. No reset action (4195KB and 4195KC controllers)	4.1 Reset valve is plugged	4.1 Turn the reset valve through its range several times to remove any restrictions	4.1 If reset action returns, no further action is necessary. If not, replace the reset valve (4195KB controllers) or rate/reset valve (4195KC controllers)
	4.2 Reset pressure leak	4.2 Adjust the output to 1.0 bar (15 psig) for a 0.2 to 1.0 bar (3 to 15 psig) output or 2.0 bar (30 psig) for a 0.4 to 2.0 bar (6 to 30 psig) output. Close the reset valve. If the output varies and no leaks were found in the rest of the feedback system (see Step 2.6), the reset valve is leaking	4.2 Replace the reset valve (4195KB controllers) or the rate/reset valve (4195KC controllers)
	4.3 Tubing leak	4.3 With reset valve positioned at .01 minute/repeat put 1.0 bar (15 psig) to the output port. Using soap solution, check for leaks in the reset bellows and attached tubing assembly	4.3 Repair or replace parts as necessary
5. Abnormal control point shift when proportional band is changed Note: Control point shift is inherent when changing proportional band in proportional-only controllers (4195KA controllers).	5.1 Flapper is out of alignment	5.1 Refer to flapper alignment procedure	5.1 Align flapper as necessary
	5.2 Flapper is dirty or pitted	5.2 Inspect the flapper	5.2 Clean, or replace flapper as necessary
6. Controller will not attain full output range	6.1 Output pressure gauge not functioning	6.1 Measure the output with an external pressure gauge	6.1 Replace the gauge if it is defective
	6.2 Supply pressure not correct	6.2 Check with an external source	6.2 Repair or replace the supply pressure regulator, if necessary. Replace the supply pressure gauge if necessary
	6.3 Proportional band setting too wide (4195KA controllers only)	6.3 Adjust proportional band setting to 10. Manually cap the nozzle. Output should increase	6.3 Use a narrower proportional band setting
	6.4 Input element or linkage failure	6.4 Inspect the element for alignment and loose screws	6.4 Repair or replace parts as necessary

(continued)

Table 6-1. Troubleshooting Chart (continued)

Fault	Possible Cause	Check	Correction
6. Controller will not attain full output range (continued)	6.5 Nozzle pressure leak	6.5 Check for nozzle tubing leaks with a water bottle and soap solution with the nozzle capped by the flapper. Press the nozzle cap (key 23) gently to ensure the nozzle assembly is sealing. Ensure the relay nozzle tubing nut (key 18) is tight and the manifold screws (keys 34 and 131) are tight	6.5 Tighten the relay nozzle tubing nut (key 18). Tighten the manifold screws (keys 34 and 131). Replace the nozzle assembly (key 21), O-ring (key 24), or set point beam assembly (key 23) as necessary if leaking
	6.6 Leak in nozzle pressure tubing	6.6 Using soap solution, check for leaks in the nozzle tubing assembly	6.6 Replace faulty parts as necessary. Clean out the relay primary orifice with the cleanout wire attached to the relay to ensure the orifice is not clogged
	6.7 Relay malfunction	6.7 Manually push the flapper away from the nozzle. The output pressure should be zero. Cap the nozzle. The output should increase rapidly to within 35 mbar (0.5 psig) of the supply pressure	6.7 If the output does not change as described, remove the relay. Replace the O-rings if necessary. Replace relay if necessary
7. Controller remains at full output	7.1 Supply pressure too high	7.1 Check with an external pressure gauge	7.1 Supply pressure regulator or gauge may have to be replaced
	7.2 Output gauge not functioning	7.2 Reduce supply pressure to 0 bar (0 psig) to see if output gauge responds	7.2 If output gauge does not respond, replace it
	7.3 Sensor or linkage failure	7.3 Vary the process pressure and observe the flapper for movement. Inspect the sensor and linkage for damage	7.3 Repair or replace parts as necessary
	7.4 Flapper mis-alignment	7.4 Vary the process pressure and verify that the nozzle can be uncapped by the flapper	7.4 Perform flapper alignment procedures
	7.5 Relay failure or restriction in nozzle passage	7.5 Loosen the relay nozzle tubing nut (key 18) with full supply pressure	7.5 If the output pressure remains at the supply pressure, replace the relay. If the output pressure moves to 0 bar (0 psig), clean or replace nozzle or nozzle tubing.
8. Controller remains at zero output	8.1 Gauge not functioning	8.1 Verify that the supply pressure is at its correct value and that the controller output is zero	8.1 Replace gauges as necessary
	8.2 Sensor or linkage failure	8.2 Vary the process pressure and observe the flapper for movement. Inspect the sensor and linkage for damage	8.2 Repair or replace parts as necessary
	8.3 Flapper misalignment	8.3 Vary the process pressure and verify that the nozzle can be capped by the flapper	8.3 Perform flapper alignment procedures
	8.4 Relay malfunction	8.4 Check for air at the nozzle. Cap the nozzle and see if the controller output increases to within 0.03 bar (0.5 psig) of supply pressure	8.4 Clean out the relay primary orifice with the cleanout wire attached to the relay to ensure the orifice is not clogged. If the problem persists, replace the relay
	8.5 Nozzle pressure leak	8.5 Check for nozzle tubing leaks with a water bottle and soap solution with the nozzle capped by the flapper. Press the nozzle cap (key 23) gently to ensure the nozzle assembly is sealing. Ensure the relay nozzle tubing nut (key 18) is tight and the manifold screws (keys 34 and 131) are tight	8.5 Tighten the relay nozzle tubing nut (key 18). Tighten the manifold screws (keys 34 and 131). Replace the nozzle assembly (key 21), O-ring (key 24), or set point beam assembly (key 23) as necessary if leaking

Replacing Common Controller Parts

⚠ WARNING

To avoid personal injury or property damage caused by the uncontrolled release of pressure, be sure any trapped process pressure is properly vented from the controller. Vent any supply pressure from the controller before disassembly.

Replacing the Process Pressure Scale

⚠ WARNING

Refer to the Maintenance WARNING on page 51.

CAUTION

To prevent the pointer or set point indicator from rubbing on the cover or scale and producing an inaccurate indication, take care not to bend the process pointer or the set point indicator while performing the following procedure.

Refer to figure 6-1.

Figure 6-1. Changing the Scale



W3440

DEFLECT LOWER PORTION OF THE SLOT



W3492

AND LIFT THE SCALE UP AND OFF

1. Adjust the set point indicator (either manually or with the remote set point pressure) to the mid-scale mark on the process scale.
2. Remove the four self-tapping screws (key 37).
3. Slide the process scale (key 61) downward so that the top of the slot touches the set point indicator. Deflect the lower portion of the slot outward and carefully slide the scale up and off, clearing the set point indicator as shown in figure 6-1.
4. To install the replacement scale, deflect the lower part of the slot slightly so that the scale slides downward over the set point indicator and under the process pointer.

5. Secure the scale with the four self-tapping screws (key 37).
6. If the controller has remote set point (suffix letter M), perform the appropriate remote set point zero and span calibration procedure in Section 3, 4, or 5.
7. Perform the appropriate process indicator zero and span calibration and the flapper alignment procedures in Section 3, 4, or 5.

Replacing the Relay

⚠ WARNING

Refer to the Maintenance WARNING on page 51.

1. Loosen the two captive screws that hold the relay (key 50) in place.
2. Tip the relay slightly toward the side of the case to clear the output pressure gauge (key 46) and lift out the relay.
3. Make sure the replacement relay has three O-rings (keys 13 and 15) installed as shown in figure 6-2. The fourth port is for exhaust and does not require an O-ring.
4. Install the replacement relay, making sure the tab on the relay, shown in figure 6-2, aligns with the tab on the frame.
5. Tighten the two screws that hold the relay in place.

Figure 6-2. Relay Construction

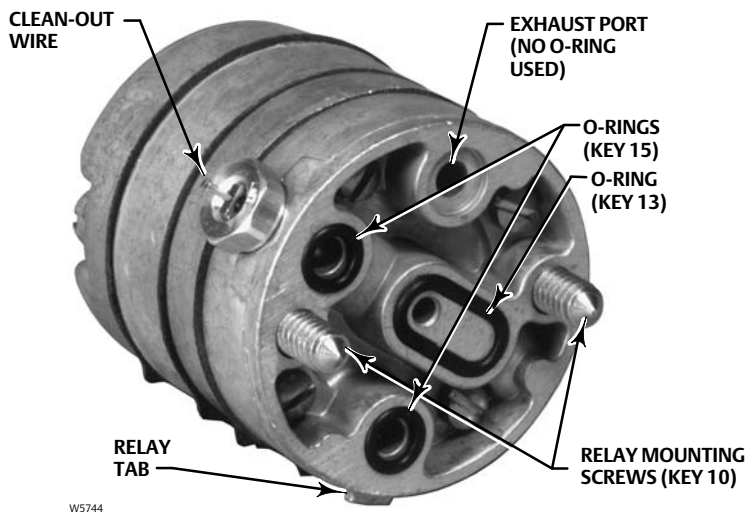

6. Perform the appropriate flapper alignment procedure in Section 3, 4, or 5.

Replacing the Case and Cover

⚠ WARNING

Refer to the Maintenance WARNING on page 51.

CAUTION

The case and cover are an integral unit; attempting to separate them will damage the hinge. If the cover needs to be replaced, replace the case also.

1. Remove the external piping and fittings from the controller.
2. Remove the controller from its mounting to a maintenance area.
3. Remove the nine screws (key 38) from the case and cover assembly (key 1) and lift out the controller assembly. If the controller has remote set point (suffix letter M), use a screwdriver or appropriate tool to deflect the case slightly at the remote set point connection to remove the controller assembly. Inspect the O-rings around the external piping connections and replace as necessary.
4. Position the controller assembly in the replacement case and cover.
5. Start the nine mounting screws, but do not tighten.
6. Slide the controller assembly down to assure an O-ring seal at the pressure connections along the bottom of the case. Hold the controller assembly in place while tightening the nine mounting screws.
7. Remove the blow-out plug (key 72) from the original case, and install it in the replacement case.
8. Perform the controller calibration procedures and, if necessary, the appropriate remote set point calibration procedure in Section 3, 4, or 5.
9. Mount the controller as described in the Installation section.
10. Connect the external piping to the controller.

Replacing the Gauges

⚠ WARNING

Refer to the Maintenance WARNING on page 51.

CAUTION

Before performing this procedure, be sure the replacement gauges are the correct range so that they are not damaged by overpressure.

1. Unscrew the output pressure gauge or the supply pressure gauge (key 46) from the frame (key 3).
2. Before installing the replacement gauge, coat the threads on the gauge with a sealant such as key 311 or equivalent.
3. Screw the replacement gauge into the frame.
4. Apply the correct supply pressure and check for leaks with the nozzle capped for full output pressure.

Replacing the Supply Gauge, Proportional, Reset, Reset Valve, and Positive Feedback Tubing Assemblies

⚠ WARNING

Refer to the Maintenance WARNING on page 51.

1. Remove the controller assembly from the case by performing steps 1 through 3 of the case and cover replacement procedure.
2. Unscrew the nuts at each end of the tubing assembly. Remove the tubing assembly.
3. Install the replacement tubing assembly.
4. Set the reset adjustment to 0.01 (4195KB and KC controllers) and set the rate adjustment to OFF (4195KC controllers).
5. Apply the correct supply pressure and check for leaks with the nozzle capped for full output pressure. Then, remove the supply pressure.
6. Position the controller assembly in the case and start, but do not tighten the nine mounting screws. Slide the controller assembly down to assure an O-ring seal at the pressure connections along the bottom of the case. Hold the controller assembly in place while tightening the nine mounting screws.
7. Perform the controller calibration procedures and, if necessary, the appropriate remote set point calibration procedure in Section 3, 4, or 5.
8. Mount the controller as described in the Installation section.
9. Connect the external piping to the controller.

Replacing the Proportional Band Adjustment Knob, Nozzle Assembly, and Set Point Beam Assembly

⚠ WARNING

Refer to the Maintenance WARNING on page 51.

Figure 6-3 shows the parts locations for the proportional band adjustment and set point beam. Unless otherwise noted, refer to this figure while performing the following procedures.

Disassembly

1. Remove the controller assembly from the case by performing steps 1 through 3 of the case and cover replacement procedure.
2. Remove the two machine screws (key 6) and lift off the proportional band indicator cover (key 36). See figure 7-1 for parts location.
3. Disconnect link 3 from the set point beam shoe, part of the set point beam assembly (key 23).
4. Remove the set point beam bias spring (key 28).
5. Remove the screw and washer (keys 19 and 20) that hold the adjustable set point pivot assembly (key 17) to the frame and remove the pivot assembly.
6. Unscrew the nut that secures the relay nozzle tubing assembly (key 18) to the frame manifold (key 135).

Figure 6-3. Proportional Band Adjustment and Set Point Beam Details

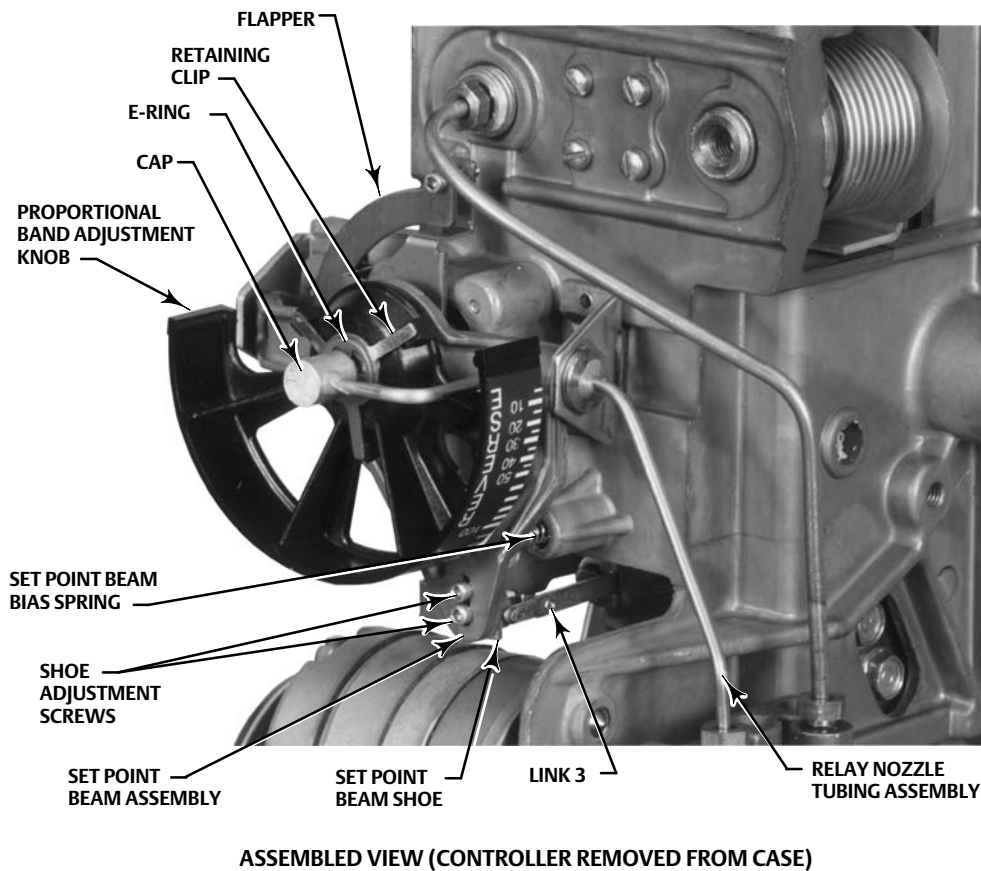
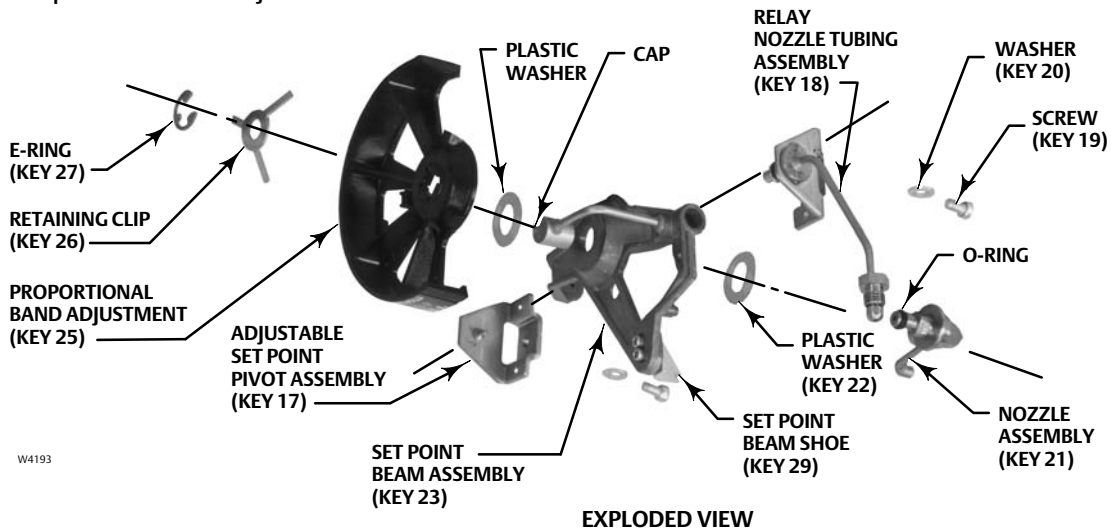

7. While holding the proportional band adjustment knob, remove the screw and washer (keys 19 and 20) that hold the relay nozzle tubing assembly (key 18) to the frame.
8. Remove the proportional band adjustment knob, relay nozzle tubing assembly, and set point beam assembly from the controller.

9. Remove the relay nozzle tubing assembly (key 18) from the set point beam assembly (key 23).
10. Remove the E-ring (key 27) from the nozzle assembly (key 21).
11. Remove the nozzle assembly (key 21) and plastic washer (key 22) from the bottom of the set point beam assembly (key 23).
12. Remove the retaining clip (key 26).
13. Remove the proportional band adjustment knob (key 25) and plastic washer from the set point beam assembly (key 23).
14. Inspect the nozzle assembly (key 21) and, if necessary, replace it. Inspect the nozzle orifice and, if necessary, clean it. Also, inspect the plastic washers and, if necessary, replace them.
15. Inspect the nozzle assembly O-ring (key 24) and, if necessary, replace it.

Assembly

1. Apply a suitable lubricant, such as key 318 or equivalent, to the set point beam assembly; then position a plastic washer (key 22) and the proportional band adjustment knob (key 25) on the set point beam assembly (key 23) as shown in figure 6-3.
2. Position the retaining clip (key 26) on the three posts on the proportional band adjustment knob.
3. Place the second plastic washer on the nozzle assembly. Apply a suitable lubricant, such as key 317 or equivalent, to the nozzle assembly O-ring.
4. Insert the nozzle assembly (key 21) through the set point beam assembly (key 23), the plastic washer (key 22), the proportional band adjustment knob (key 25), and the retaining clip (key 26) into the cap. Align the nozzle with the tab on the proportional band adjustment knob shown in figure 6-4; make sure the proportional band adjustment knob engages the flats on the nozzle assembly.
5. While holding the nozzle assembly (key 21) against the set point beam assembly (key 23), depress the retaining clip (key 26), and install the E-ring (key 27) into the E-ring groove on the nozzle assembly (key 21). Ensure that all three tabs of the E-ring are engaged.
6. Inspect the O-ring on the relay nozzle tubing assembly (key 18) and, if necessary, replace it. Apply a suitable lubricant to the O-ring.
7. Install the relay nozzle tubing assembly (key 18) into the set point beam assembly.
8. Set the proportional band adjustment between DIRECT and REVERSE. Do this by aligning the tab on the proportional band adjustment knob with the hole in the set point beam assembly as shown in figure 6-4.
9. Position the proportional band adjustment knob, relay nozzle tubing assembly, and the set point beam assembly on the frame. Screw the relay nozzle tubing nut loosely into the frame manifold.
10. Insert the machine screw, with plain washer (keys 19 and 20), through the frame and start it into the relay nozzle tubing assembly (key 18), but do not tighten.
11. Center the nozzle on the flapper as shown in figure 6-5 while squeezing the set point beam assembly firmly against the relay nozzle tubing assembly. With the nozzle centered on the flapper, tighten the machine screw (key 19). Ensure that the nozzle is still centered on the flapper.
12. Insert the pivot of the adjustable set point pivot assembly (key 17) into the hole in the set point beam assembly (key 23).
13. Insert the screw, with washer (keys 19 and 20), through the frame (key 3) and start it into the adjustable set point pivot assembly (key 17), but do not tighten.
14. Squeeze the adjustable set point pivot assembly against the set point beam assembly. Check to be sure the nozzle is still centered on the flapper and tighten the machine screw (key 19). If necessary, loosen both machine screws (key 19) to allow slightly moving the adjustable set point pivot assembly, set point beam assembly and the relay nozzle tubing assembly as a unit to center the nozzle on the flapper. After centering the nozzle, tighten the two machine screws.

- Turn the proportional band adjustment knob to 5 percent DIRECT. Refer to figure 6-6 to locate the locking nut on the adjustable set point pivot assembly. Loosen the locking nut and back out the set screw slightly so that the set point beam assembly falls under its own weight when pivoted upward. Also, maintain a minimum side play between the adjustable set point pivot assembly and the nozzle tubing assembly. Tighten the locking nut.

Figure 6-4. Proportional Band Adjustment Knob Setting

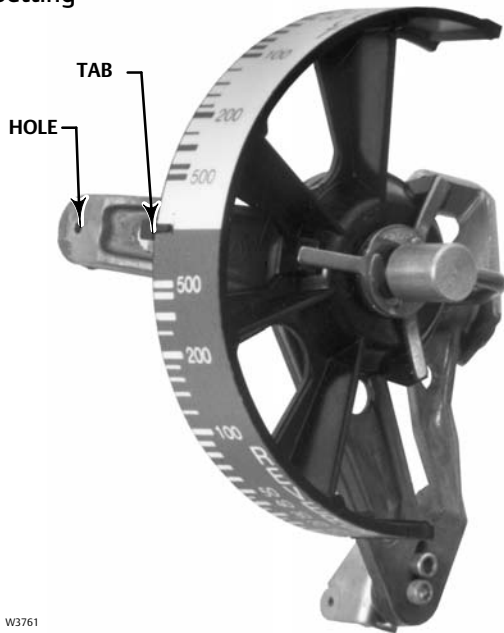

W3761

Figure 6-5. Nozzle-Flapper Positioning

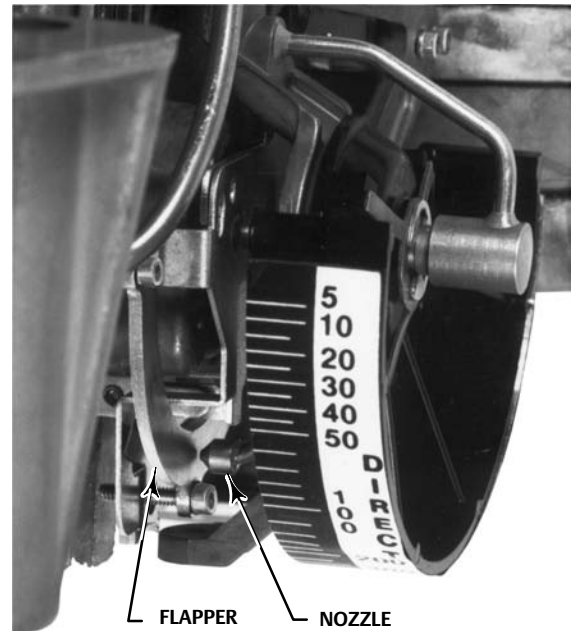

W3449

Figure 6-6. Adjustable Set Point Pivot Assembly Locking Nut Location

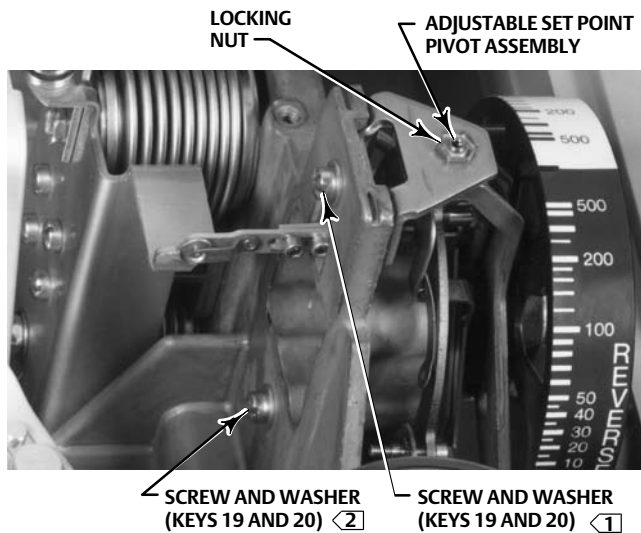

NOTES:

- SCREW INSERTED INTO THE ADJUSTABLE SET POINT PIVOT ASSEMBLY.
- SCREW INSERTED INTO THE RELAY NOZZLE TUBING ASSEMBLY.

W4195

16. At the frame manifold (key 135), tighten the nut that secures the tubing from the relay nozzle tubing assembly (key 18). Apply full supply pressure with the nozzle capped and check for leaks. Remove supply pressure.
17. Install the set point beam bias spring (key 28) into the frame bore and onto the spring seat on the set point beam assembly.
18. Attach link 3 to the set point beam shoe as shown in figure 6-3.
19. For controllers with reset or rate adjustment (4195KB or 4195KC controllers), turn the reset adjustment to the CLOSED (4195KB) or OFF (4195KC) position. Set the rate adjustment to the OFF position.

The controller output must be 0 bar (0 psig). To be sure the controller output is 0 bar (0 psig), remove supply pressure, set the reset adjustment to 0.01 minutes per repeat and wait 30 seconds; then, turn the reset adjustment to the CLOSED position (4195KB) or to the OFF position (4195KC).

20. Apply the correct supply pressure (refer to table 1-6) to the controller and provide an accurate means of measuring the controller output pressure.
21. Perform the appropriate process indicator zero and span calibration procedure and, if necessary, the remote set point zero and span calibration procedure in Section 3, 4, or 5. When calibration is complete, continue with step 22 below.

Note

The following procedure (steps 22 through 28) matches the process pointer motion to the set point indicator motion so the controller will control at set point at all positions on the process scale.

22. Set the proportional band to 40 percent in REVERSE or DIRECT depending on the desired controller action.
23. Adjust the set point to the lower limit on the process scale.
24. Disconnect link 1 from the input element, noting the hole from which it is removed, for capsular input elements, and tape the process pointer to the lower limit on the process scale. The output pressure may be anywhere between 0.2 to 1.0 bar (3 to 15 psig) for a 0.2 to 1.0 bar (3 to 15 psig) output signal range or between 0.4 to 2.0 bar (6 to 30 psig) for a 0.4 to 2.0 bar (6 to 30 psig) output signal range. If the output is not within the specified range, adjust the flapper leveling screw nearest the nozzle until the output is within the range specified. Record the controller output pressure.
25. Adjust the set point to the upper limit on the process scale.
26. Remove the tape and move the process pointer until the controller output equals the pressure recorded in step 24. Note the process pressure indication.
27. The process pressure indication should be within ± 2 percent of the upper limit on the process scale.

If the process pressure indication in step 26 is greater than the upper limit of the process scale by 2 percent, loosen the shoe adjustment screws (key 30), shown in figure 6-3, and move the set point beam shoe (key 29) slightly away from the center of the flapper assembly.

If the process pressure indication in step 26 is less than the upper limit of the process scale by 2 percent, loosen the shoe adjustment screws (key 30), shown in figure 6-3, and move the set point beam shoe (key 29) slightly toward the center of the flapper assembly.

28. Repeat steps 23 through 27 until the error is less than 2 percent of process scale span at the upper limit of the process scale.
29. Remove the tape from the process pointer and reconnect link 1 to the input element. If the controller has a capsular input element, be sure to reconnect link 1 in the same hole noted in step 24.
30. Position the controller assembly in the case and start, but do not tighten the nine mounting screws. Slide the controller assembly down to assure an O-ring seal at the pressure connections along the bottom of the case. Hold the controller assembly in place while tightening the nine mounting screws.

31. Perform the controller calibration procedures and, if necessary, the appropriate remote set point calibration procedure in Section 3, 4, or 5.
32. Mount the controller as described in the Installation section.
33. Connect the external piping to the controller.

Replacing the Flapper Assembly and Flapper Flexure Pivot Assembly

⚠ WARNING

Refer to the Maintenance WARNING on page 51.

1. Remove the controller assembly from the case by performing steps 1 through 3 of the case and cover replacement procedure.
2. Remove the two screws (key 6) and lift off the proportional band indicator cover (key 36).
3. Disconnect link 3 from the set point beam shoe, part of the set point beam assembly (key 23). Refer to figure 6-3 for the link location.
4. Remove the set point beam bias spring (key 28). Refer to figure 6-3 for the spring location.
5. Remove the screw and washer (keys 19 and 20) that hold the adjustable set point pivot assembly (key 17) to the frame.
6. Remove the adjustable set point pivot assembly (key 17).
7. Unscrew the nut that secures the relay nozzle tubing assembly (key 18) to the frame manifold (key 135). Refer to figure 6-3.
8. While holding the proportional band adjustment knob, remove the screw and washer (keys 19 and 20) that hold the relay nozzle tubing assembly (key 18) to the frame.
9. Remove the proportional band adjustment knob, relay nozzle tubing assembly, and the set point beam assembly from the controller.
10. Disconnect link 2 from the flapper assembly (key 11). Refer to figure 6-7 for the link location.
11. Disconnect link 4 from the bellows bracket (key 31). Refer to figure 6-7 for the link location.
12. Remove the two cap screws (key 12) from the flexure pivot assembly (key 9). See figure 6-8 for screw location.
13. Remove the flapper assembly and link 4 as shown in figure 6-9.
14. Remove the four machine screws (key 10), shown in figure 6-9, that hold the flexure pivot assembly to the frame.
15. Remove the flexure pivot assembly (key 9).
16. Install the replacement flexure pivot assembly with the four screws (key 10). Do not tighten the screws.
17. With the controller in the upright position, move the flexure pivot assembly down as far as possible and tighten the four screws (key 10).
18. Place the flapper assembly (key 11) on the flexure pivot assembly (key 9) with link 4 through the hole in the frame.
19. Position the flapper assembly (key 11) on the flexure pivot assembly (key 9) and start the cap screws (key 12) that hold the flapper assembly to the flexure pivot assembly. Do not tighten the screws.

Figure 6-7. Bellows Assembly and Proportional Band Adjustment (Process Scale and Proportional Band Indicator Cover Removed)

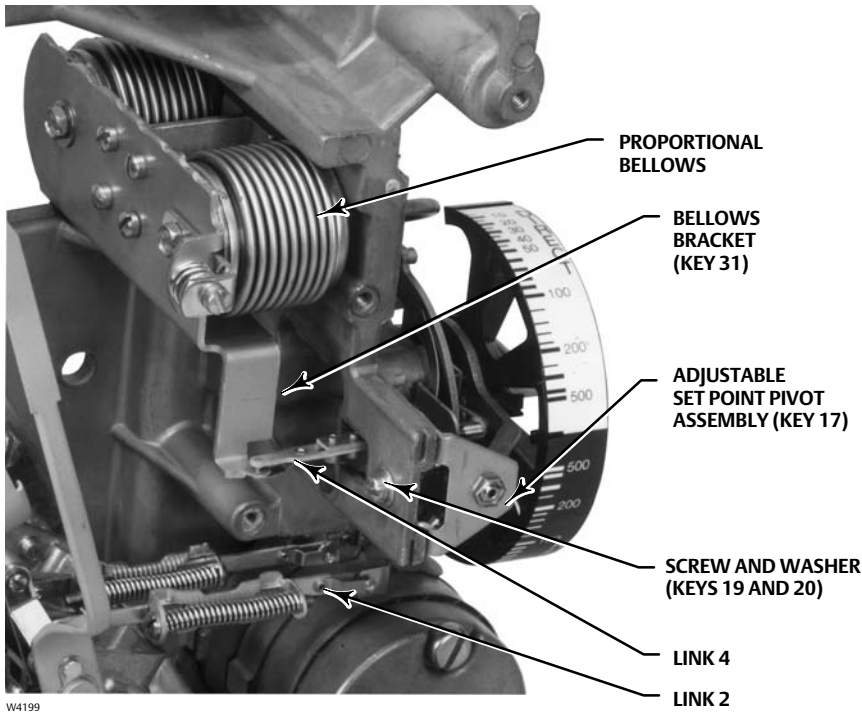

Figure 6-8. Leveling Screw Alignment

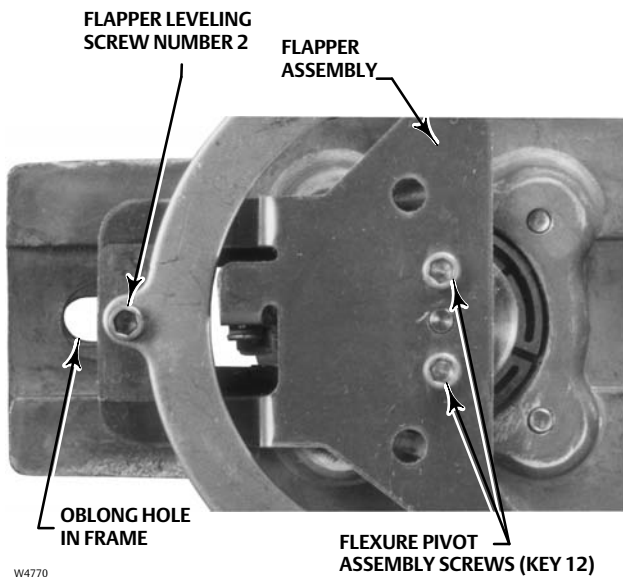
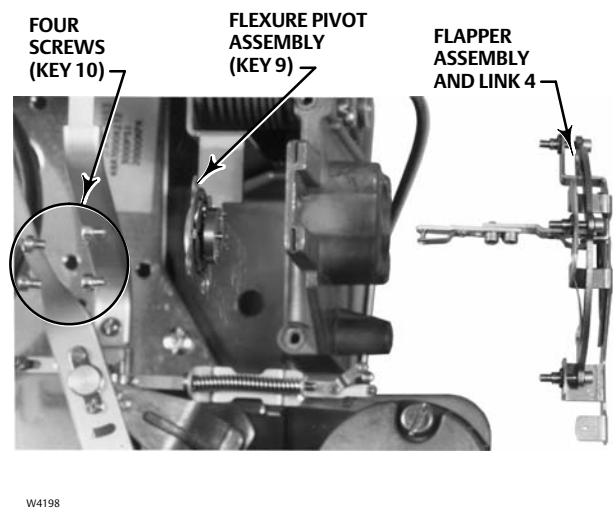

Figure 6-9. Exploded View of Flexure Pivot Assembly



20. Align flapper leveling screw number 2 with the centerline of the oblong hole in the frame as shown in figure 6-8. Tighten the cap screws (key 12).

Note

The following procedure (steps 21 through 23) adjusts link 2 to ensure that it will always be in tension to eliminate possible instability due to lost motion.

21. Disconnect link 1 from the input element, noting the hole location if the controller has a capsular input element, and manually position the process pointer to the process scale upper limit. Tape the pointer in this position.
22. Adjust the length of link 2 by turning the adjustment screw, shown in figure 6-10, clockwise to increase the length or counterclockwise to decrease the length, so that the pin on the end of the link is approximately one-half of its diameter short of aligning with the hole in the flapper assembly, as shown in figure 6-11.

Figure 6-10. Link 2 and 4 Adjustment Locations



W3442-1

Figure 6-11. Link 2 Adjustment

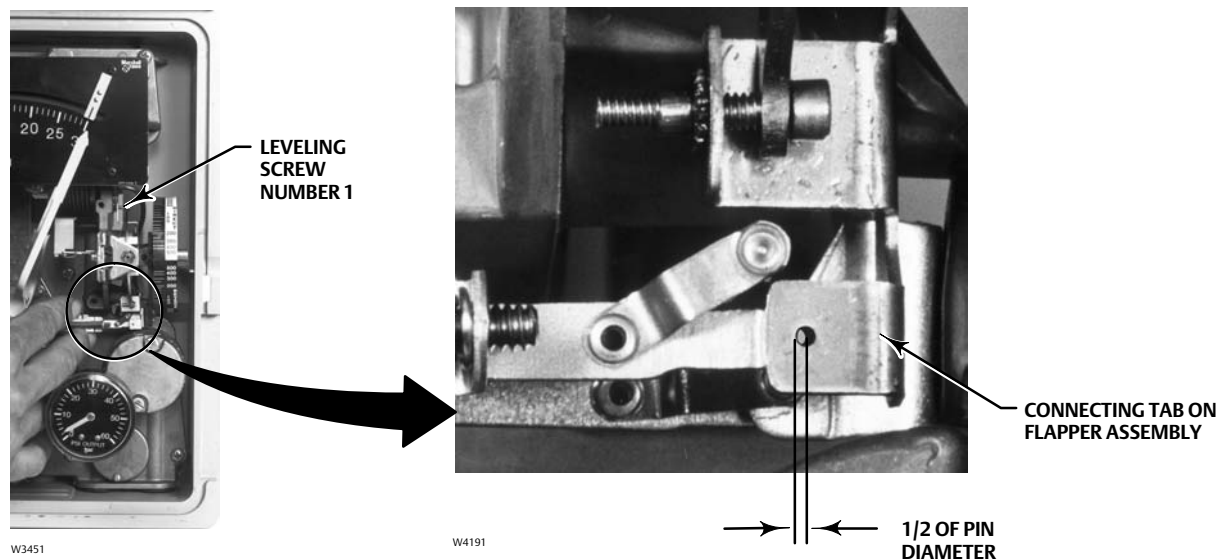

23. Connect link 2 to the flapper assembly.
24. Set the proportional band between DIRECT and REVERSE. Do this by aligning the tab on the proportional band adjustment knob with the hole in the set point beam assembly as shown in figure 6-4.
25. Position the proportional band adjustment knob, nozzle assembly, and set point beam assembly, and nozzle tubing assembly on the frame, and screw the relay nozzle tubing assembly nut loosely into the frame manifold (key 135).
26. Insert the machine screw, with washer (keys 19 and 20), through the frame and start it into the relay nozzle tubing assembly (key 18), but do not tighten.
27. Center the nozzle on the flapper as shown in figure 6-5 while squeezing the set point beam assembly firmly against the relay nozzle tubing assembly. With the nozzle centered on the flapper, tighten the machine screw (key 19). Ensure that the nozzle is still centered on the flapper.
28. Insert the pivot of the adjustable set point pivot assembly (key 17) into the hole in the set point beam assembly (key 23).
29. Insert the screw, with washer (keys 19 and 20), through the frame (key 3) and start it into the adjustable set point pivot assembly (key 17), but do not tighten.
30. Squeeze the adjustable set point pivot assembly against the set point beam assembly. Check to be sure the nozzle is still centered on the flapper and tighten the machine screw (key 19). If necessary, loosen both machine screws (key 19) to allow slightly moving the adjustable set point pivot assembly, set point beam assembly and the relay nozzle tubing assembly as a unit to center the nozzle on the flapper. After centering the nozzle, tighten the two machine screws.
31. Turn the proportional band adjustment knob to 5 percent DIRECT. Refer to figure 6-6 to locate the locking nut on the adjustable set point pivot assembly. Loosen the locking nut and back out the set screw slightly so that the set point beam assembly falls under its own weight when pivoted upward. Also, maintain a minimum side play between the adjustable set point pivot assembly and the nozzle tubing assembly. Tighten the locking nut.
32. At the frame manifold (key 135), tighten the nut that secures the tubing from the relay nozzle tubing assembly (key 18). Apply full supply pressure with the nozzle capped (to obtain maximum output pressure) and check for leaks. Remove supply pressure.
33. Install the set point beam bias spring (key 28) into the frame bore and onto the spring seat on the set point beam assembly, as shown in figure 6-3.

34. Attach link 3 to the set point beam shoe as shown in figure 6-3.

Note

The following procedure (steps 35 through 41) adjusts link 4 so it will always be in compression to eliminate possible instability due to lost motion.

35. For controllers with reset and rate adjustments (4195KB or 4195KC controllers), remove the supply pressure; then turn the reset adjustment to the CLOSED (4195KB) or OFF (4195KC) position.

The controller output must be 0 bar (0 psig). To be sure the controller output is 0 bar (0 psig), remove supply pressure, set the reset adjustment to 0.01 minutes per repeat and wait 30 seconds; then, turn the reset adjustment to the CLOSED (4195KB) or OFF (4195KC) position.

36. Apply the correct supply pressure (refer to table 1-6) to the controller and provide an accurate means of measuring the controller output pressure.
37. Adjust the proportional band to 5 percent REVERSE and adjust the set point to the process scale upper limit.
38. With link 1 disconnected, tape the process pointer at the process scale lower limit. The output pressure should be within 0.14 bar (2 psig) of the supply pressure. If not, adjust flapper leveling screw 1 (the screw nearest the nozzle) until the output is within 0.14 bar (2 psig) of supply pressure.
39. Loosen the two adjustment screws on link 4, shown in figure 6-10, and connect the link to the bellows bracket (key 31), allowing the link to find its free length.
40. Tighten the two adjusting screws on link 4.
41. Lift link 4 out of the hole in the bellows bracket (key 31) and ensure it drops back into the hole under its own weight. If not, repeat steps 39 and 40.
42. Adjust the proportional band to 40 percent REVERSE or DIRECT depending on the desired controller action.
43. Adjust the set point to the process scale lower limit.
44. Tape the process pointer at the process scale lower limit. The output pressure may be anywhere between 0.2 to 1.0 bar (3 and 15 psig) for a 0.2 to 1.0 bar (3 to 15 psig) output signal range or between 0.4 to 2.0 bar (6 and 30 psig) for a 0.4 to 2.0 bar (6 to 30 psig) output signal range. If the output is not within the specified range, adjust the flapper leveling screw nearest the nozzle until the output is within the range specified. Record the controller output pressure.
45. Adjust the set point to the process scale upper limit.
46. Remove the tape and move the process pointer until the controller output equals the pressure recorded in step 44. Note the process pressure indication.
47. The process pressure indication should be within ± 2 percent of the process scale upper limit.

If the process pressure indication in step 46 is greater than the process scale upper limit by 2 percent, loosen the shoe adjustment screws (key 30), shown in figure 6-3, and move the set point beam shoe (key 29) slightly away from the center of the flapper assembly.

If the process pressure indication in step 46 is less than the process scale upper limit by 2 percent, loosen the shoe adjustment screws (key 30), shown in figure 6-3, and move the set point beam shoe (key 29) slightly toward the center of the flapper assembly.

48. Repeat steps 43 through 47 until the error is less than 2 percent of the process scale span at the process scale upper limit.
49. Remove the tape from the process pointer and reconnect link 1 to the input element. If the controller has a capsular input element, be sure to reconnect link 1 in the same hole noted in step 21.
50. Position the controller assembly in the case and start, but do not tighten the nine mounting screws. Slide the controller assembly down to assure an O-ring seal at the pressure connections along the bottom of the case. Hold the controller assembly in place while tightening the nine mounting screws.

51. Perform the controller calibration procedures and, if necessary, the appropriate remote set point calibration procedure in Section 3, 4, or 5.
52. Mount the controller as described in the Installation section.
53. Connect the external piping to the controller.

Replacing the Proportional, Reset or Positive Feedback Bellows

▲ WARNING

Refer to the Maintenance WARNING on page 51.

Refer to figure 6-12, unless otherwise noted.

1. Remove the controller assembly from the case by performing steps 1 through 3 of the case and cover replacement procedure.
2. Remove the two screws (key 6) and lift off the proportional band indicator cover (key 36).
3. Disconnect link 4 (key 65) from the bellows bracket (key 31).
4. Remove the two machine screws (key 35) and washer (key 362) from the bellows assemblies.
5. Remove the four machine screws (key 6) from the bellows beam (key 49) and remove the bellows bracket (key 31).
6. Remove the proportional tubing assembly (key 40) from the proportional bellows, the reset tubing assembly (key 43) from the reset bellows or the positive feedback tubing assembly (key 45) from the positive feedback bellows, depending on which bellows is to be replaced.
7. Remove the four machine screws (key 71) from the bellows beam and remove the bellows beam from the frame.

Figure 6-12. Bellows Assembly, Bellows Bracket, and Bellows Beam Location

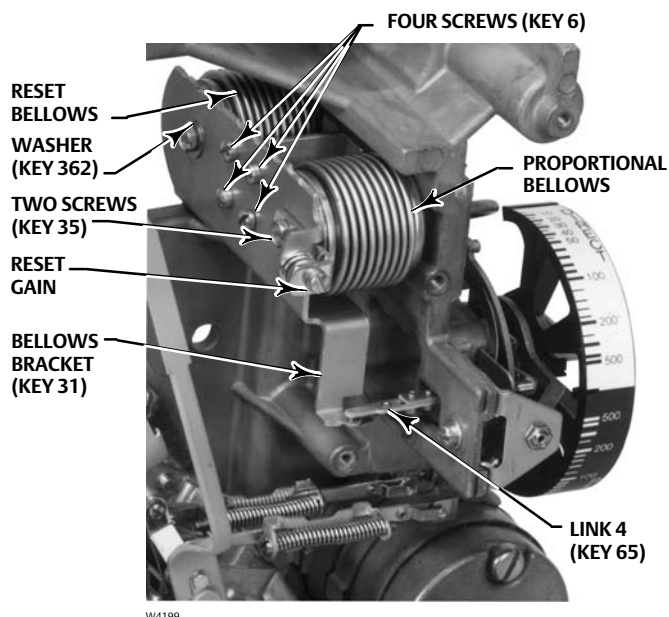

W4199

CAUTION

When removing and replacing the proportional, reset, or positive feedback bellows, keep in mind that the bellows has left-hand threads. Overtightening could damage the threads.

Note

Both bellows need not be removed if only one requires replacement.

8. Unscrew the bellows assembly (key 48). If the bellows assembly cannot be removed by hand, thread a machine screw (key 35) into the bellows until tight; then loosen the bellows assembly by applying clockwise torque to the machine screw.
9. Before installing the replacement bellows, coat the threads with a suitable lubricant, such as key 310. Screw in the replacement bellows until it is finger tight against the frame (key 3).
10. Reinstall the bellows beam (key 49) and tighten the machine screws (key 71).
11. Position the bellows bracket (key 31) over the bellows. Insert a machine screw (key 35) through the bellows bracket (key 31) and into the proportional bellows. Do not tighten.
12. Place the washer (key 362) on the second machine screw (key 35) and start the screw through the bellows bracket (key 31) into the reset bellows. Do not tighten.
13. Compress the bellows and start the four machine screws (key 6) through the bellows bracket (key 31) into the bellows beam (key 49), but do not tighten.
14. Be sure that the bellows bracket is aligned such that it does not rub on the frame at any point and tighten the screws (keys 6 and 35).
15. Install the proportional, reset, or positive feedback tubing assembly on the bellows base.
16. For a 4195KB or KC controller, set the reset adjustment for 0.01 minutes per repeat. For a 4195KC controller, set the rate adjustment to OFF.
17. Apply the correct supply pressure with the nozzle capped and check for leaks. Remove the supply pressure.
18. Reconnect link 4 (key 65) to the bellows bracket. Be sure that the link does not contact the frame. If it does, loosen the four screws (key 6) that attach the bellows bracket to the bellows beam and reposition the bellows bracket to provide clearance. Be sure the bellows bracket does not rub on the frame; then, tighten the screws.
19. Lift link 4 out of the hole in the bellows bracket (key 31) and ensure it drops back into the hole under its own weight. If not, perform steps 35 through 41 of the flapper assembly and flapper flexure pivot assembly replacement procedures.
20. If the controller is a proportional-only (4195KA or KS controller), go to step 33. If the controller has reset (4195KB or KC controller), continue with step 21.

Note

The following procedure (steps 21 through 32) adjusts the reset gain of the controller to minimize steady-state offset.

21. Apply the correct supply pressure (refer to table 1-6) to the controller and provide an accurate means of measuring the controller output pressure. Also provide a means of applying regulated process pressure.
22. Adjust the proportional band to 100 percent DIRECT.
23. Adjust the set point to the mid-scale mark on the process scale.

24. Adjust the reset adjustment to 0.01 minutes per repeat. For a 4195KC controller, set the rate adjustment to OFF.
25. Increase the process pressure until the output pressure stabilizes at 0.2 bar (3 psig) for a 0.2 to 1.0 bar (3 to 15 psig) output or 0.4 bar (6 psig) for a 0.4 to 2.0 bar (6 to 30 psig) output. Record the process pressure reading.

Note

When the reset valve is at 0.01, the controller is very sensitive to any process pressure change. Only small process pressure changes may be necessary.

26. Very slowly increase the process pressure until the output pressure stabilizes at 1.0 bar (15 psig) for a 0.2 to 1.0 bar (3 to 15 psig) output or 2.0 bar (30 psig) for a 0.4 to 2.0 bar (6 to 30 psig) output. Record the process pressure reading.
27. If the difference between the recorded process pressure in step 25 and the process pressure in step 26 is larger than ± 1 percent of the process scale span, proceed with step 28. If the difference is less than ± 1 percent, go to step 33.
28. Loosen the proportional bellows screw (key 35).
29. If the reading recorded in step 26 is greater than in step 25, adjust the reset gain screw (key 34) one-half turn in (clockwise). If the reading recorded in step 26 is less than in step 25, adjust the gain screw (key 34) one-half turn out (counterclockwise).
30. Tighten the proportional bellows screw (key 35).
31. Repeat steps 25 through 30 until the difference is less than ± 1 percent of the process scale span.
32. If ± 1 percent of process scale span cannot be achieved by adjusting the gain screw (key 34), loosen the machine screw (key 35) attaching the reset bellows and slide it to the left if the reading in step 26 is greater than in step 25, or to the right if the reading in step 26 is less than in step 25. Tighten the screw and repeat steps 25 through 31.
33. Remove the supply pressure, the output measurement device, and the regulated process pressure source.
34. Position the controller assembly in the case and start, but do not tighten the nine mounting screws. Slide the controller assembly down to assure an O-ring seal at the pressure connections along the bottom of the case. Hold the controller assembly in place while tightening the nine mounting screws.
35. Perform the controller calibration procedures and, if necessary, the appropriate remote set point calibration procedure in Section 3, 4, or 5.
36. Mount the controller as described in the Installation section.
37. Connect the external piping to the controller.

Replacing the Reset Restriction Valve (4195KB Controllers)

▲ WARNING

Refer to the Maintenance **WARNING** on page 51.

Refer to the 4195KB controller portion of figure 7-1 for key number locations.

1. Remove the controller assembly from the case by performing steps 1 through 3 of the case and cover replacement procedure.
2. Remove the reset valve tubing assembly (key 42) from the reset restriction valve (key 54).
3. Remove the reset tubing assembly (key 43) from the reset restriction valve.

4. For controllers with anti-reset windup (suffix letter F), remove the relief valve tubing assembly (key 44) from the reset restriction valve.
5. Remove the screw (key 162) that fastens the reset restriction valve to the frame.
6. Install the replacement reset restriction valve and secure it with the screw removed in step 5.
7. Install the reset valve tubing assembly (key 42), the reset tubing assembly (key 43), and for controllers with anti-reset windup, the relief tubing assembly (key 44). Tighten all connections.
8. Set the reset adjustment to 0.01 minutes per repeat.
9. Apply the proper supply pressure to the controller, cap the nozzle and check for leaks. Remove the supply pressure.
10. Position the controller assembly in the case and start, but do not tighten the nine mounting screws. Slide the controller assembly down to assure an O-ring seal at the pressure connections along the bottom of the case. Hold the controller assembly in place while tightening the nine mounting screws.
11. Perform the controller calibration procedures and, if necessary, the appropriate remote set point calibration procedure in Section 4.
12. Mount the controller as described in the Installation section.
13. Connect the external piping to the controller.

Replacing the Rate/Reset Valve Assembly (4195KC Controllers)

▲ WARNING

Refer to the Maintenance **WARNING** on page 51.

Note

Read this entire procedure before removing any parts. Refer to the 4195KC portion of figure 7-1 for key number locations.

1. Remove the controller assembly from the case by performing steps 1 through 3 of the case and cover replacement procedure.
2. Remove the two machine screws (key 71) on the side of the rate/reset valve assembly (key 262).
3. Gently pull the rate tubing assembly away from the rate/reset assembly and, remove the gasket (key 5) from the side of the rate/reset assembly.
4. Unscrew the nut holding the reset tubing assembly (key 43) into the rate/reset valve assembly.
5. Unscrew the nut holding the proportional tubing assembly (key 40) into the rate/reset assembly.
6. For controllers with anti-reset windup (suffix letter F), unscrew the nut holding the relief tubing assembly (key 44) into the rate/reset assembly.
7. While holding the rate/reset valve assembly, remove the machine screw (key 162) from the frame.
8. Remove the rate/reset valve assembly from the frame.
9. Inspect and, if necessary, replace the gasket (key 5).
10. To install the replacement rate/reset valve assembly, position the assembly on the frame (key 3) and secure it with the mounting screw (key 162).
11. Position the gasket (key 5) on the rate/reset valve assembly. Hold the gasket in place while installing the rate tubing assembly (key 137) on the valve assembly using the two machine screws (key 71).
12. Insert the reset tubing assembly (key 43) into the rate/reset valve assembly and tighten the nut.
13. Insert the proportional tubing assembly (key 40) into the rate/reset valve assembly and tighten the nut.

14. For controllers with anti-reset windup (suffix letter F), insert the relief tubing assembly (key 44) into the rate/reset valve assembly and tighten the nut.
15. Set the reset to 0.01 minutes per repeat and the rate to OFF.
16. Apply the proper supply pressure to the controller and check for leaks. Remove the supply pressure.
17. Position the controller assembly in the case and start, but do not tighten the nine mounting screws. Slide the controller assembly down to assure an O-ring seal at the pressure connections along the bottom of the case. Hold the controller assembly in place while tightening the nine mounting screws.
18. Perform the controller calibration procedures and, if necessary, the appropriate remote set point calibration procedure in Section 4.
19. Mount the controller as described in the Installation section.
20. Connect the external piping to the controller.

Replacing the Anti-Reset Windup (suffix letter F) Differential Relief Valve

⚠ WARNING

Refer to the Maintenance WARNING on page 51.

Refer to the 4195KB or 4195KC suffix letter F portion of figure 7-1 for key number locations.

1. Loosen the two mounting screws in the differential relief valve (key 55) and remove the relief valve.
2. Inspect the O-rings on the replacement relief valve. Apply a suitable lubricant to the O-rings.
3. Install the replacement relief valve into the controller frame, keeping in mind that:
 - When the arrow points up, the valve relieves with decreasing output pressure.
 - When the arrow points down, the valve relieves with increasing output pressure.
4. Tighten the two screws that hold the relief valve to the frame.
5. The relief valve differential pressure is factory-set at 0.3 bar (5 psig). Maximum differential pressure is 0.5 bar (7 psig); minimum differential pressure is 0.14 bar (2 psig). If a different differential pressure setting is desired, refer to the anti-reset windup valve calibration procedure in Section 4.

Replacing the Anti-Reset Windup (suffix letter F) Relief Valve Tubing Assembly

⚠ WARNING

Refer to the Maintenance WARNING on page 51.

Refer to the 4195KB or 4195KC suffix letter F portion of figure 7-1 for key number locations.

1. Remove the controller assembly from the case by performing steps 1 through 3 of the case and cover replacement procedure.
2. Loosen the nuts at both ends of the relief valve tubing (key 44) and remove the tubing.
3. Install the replacement relief valve tubing, and tighten the tubing nuts at both ends.
4. Apply the proper supply pressure to the controller, cap the nozzle and check for leaks. Remove the supply pressure.

5. Position the controller assembly in the case and start, but do not tighten the nine mounting screws. Slide the controller assembly down to assure an O-ring seal at the pressure connections along the bottom of the case. Hold the controller assembly in place while tightening the nine mounting screws.
6. Perform the controller calibration procedures and, if necessary, the appropriate remote set point calibration procedure in Section 4.
7. Mount the controller as described in the Installation section.
8. Connect the external piping to the controller.

Bourdon Tube Controller Maintenance and Calibration

Replacing the Bourdon Tube

⚠ WARNING

Refer to the Maintenance WARNING on page 51.

Refer to figure 7-2 for key number locations. Refer to figure 6-13 for a detailed photograph of the Bourdon tube controller link locations and adjustments.

1. Disconnect link 1 (key 382) from the Bourdon tube (key 383) as shown in figure 6-14.
2. Unscrew the tubing nut from the Bourdon tube to allow for Bourdon tube removal.
3. Remove the self-tapping screws (key 384) that fasten the Bourdon tube (key 383) to the indicator assembly (key 101).
4. With care, separate the Bourdon tube (key 383) from the process tubing assembly (key 381) and lift out the Bourdon tube.
5. Carefully place the replacement Bourdon tube in position and start the two self-tapping screws. Connect the process tubing assembly then tighten the self-tapping screws to secure the Bourdon tube.
6. Apply process pressure equal to the process scale upper limit and check for leaks. Remove process pressure.
7. Connect link 1 to the Bourdon tube.
8. With the process pressure at 0 percent, the process pointer should indicate 0 percent on the process scale. If not, loosen the two screws on link 1 and adjust the length of link 1 to position the process pointer at 0 percent. Tighten the screws.
9. Perform the controller calibration procedures and, if necessary, the appropriate remote set point calibration procedure in Section 3, 4, or 5.

Figure 6-13. Bourdon Tube Controller Link Locations and Adjustments

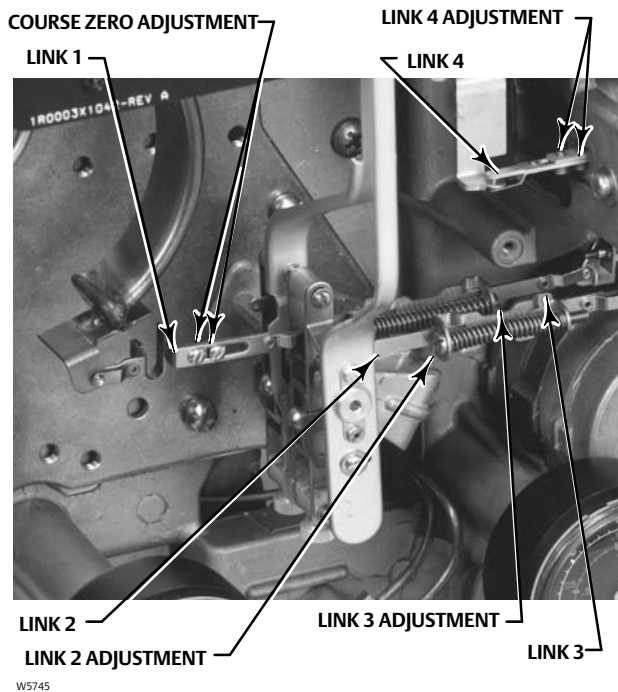
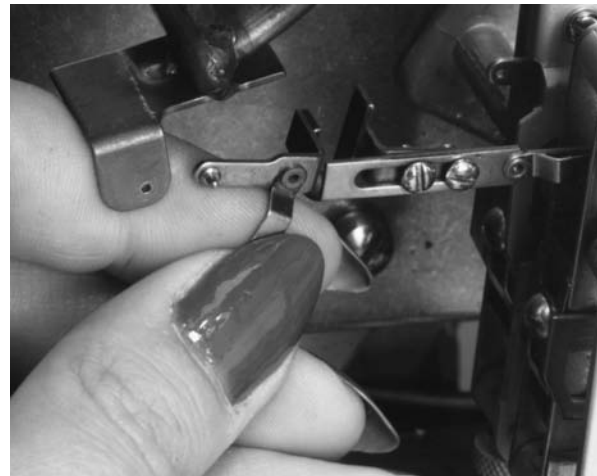

Figure 6-14. Disconnecting Link 1 from the Bourdon Tube



W5747

Replacing Bourdon Tube Controller Links

⚠ WARNING

Refer to the Maintenance WARNING on page 51.

This section describes the separate replacement of four links in the controller. Figure 6-13 shows the location of each link. To clarify the location of each link, the links are numbered as follows:

- Link 1 connects the Bourdon tube and the process pointer
- Link 2 connects the process pointer and the flapper assembly (key 11)
- Link 3 connects the set point indicator and the set point beam assembly (key 23)
- Link 4 (key 65) connects the flapper assembly and the bellows bracket (key 31).

Replacing Bourdon Tube Controller Link 1

1. Remove the two screws (key 6), and lift off the proportional band indicator cover (key 36).
2. Note the hole position of link 1 in the process pointer. As shown in figure 6-14, disconnect the link from the Bourdon tube and from the process pointer. Adjust the length of the replacement link to the same length as the link being replaced.
3. Attach the replacement link to the original holes in the process pointer and the Bourdon tube. If you do not know in which hole in the process pointer the link was connected, place it in the middle hole. If during the process indicator zero and span calibration, the pointer will not travel the full scale even after full span adjustment, move the link to

the bottom hole (the hole nearest the pointer pivot). If the process pointer has too much travel, move the link to the top hole (the hole furthest from the pointer pivot).

4. Move the set point Indicator, either manually or with remote set point pressure, to the mid-scale mark on the process scale and set the proportional band between DIRECT and REVERSE.
5. The process pointer should be aligned with the pointer subassembly as shown in figure 6-15. If not, loosen the zero adjustment locking screw and adjust the process pointer zero adjustment to align the process pointer and pointer subassembly. Tighten the zero adjustment locking screw.

Figure 6-15. Process Pointer Alignment



ALIGNED

W3443-1



ZERO ADJUSTMENT LOCKING SCREW

MISALIGNED

FINE ZERO ADJUSTMENT

W3475-1

6. Apply process pressure equal to the mid-scale value of the process scale span. The process pointer should indicate mid-scale ± 3 percent of the process scale span. If not, loosen the two screws in link 1 and move the process pointer to the mid-scale mark on the process scale. Tighten the screws.
7. Perform the controller calibration procedures and, if necessary, the appropriate remote set point calibration procedure in Section 3, 4, or 5.

Replacing Bourdon Tube Controller Link 2

1. Remove the two screws (key 6), and lift off the proportional band indicator cover (key 36).
2. Disconnect link 2 from the process pointer and from the flapper assembly (key 11). Remove the link.
3. Install the replacement link with the screw head nearest the process pointer as shown in figure 6-13. Connect the link to the process pointer only.
4. The process pointer should be aligned with the pointer subassembly as shown in figure 6-15. If not, loosen the zero adjustment locking screw and adjust the process pointer zero adjustment to align the process pointer and pointer subassembly. Tighten the zero adjustment locking screw.
5. Move the set point indicator, either manually or with the remote set point pressure, to the process scale lower limit and set the proportional band to 5 percent REVERSE. The nozzle should not be touching the flapper. If it is, adjust flapper leveling screw 1 (the screw nearest the nozzle) until clearance is obtained.

6. Disconnect link 1 from the Bourdon tube and manually position the process pointer to the process scale upper limit. Tape the pointer in this position.
7. Adjust the length of link 2 (by turning the adjusting screw clockwise to increase the length or counterclockwise to decrease the length) so that the pin on the end of the link is approximately one-half of its diameter short of aligning with the hole in the flapper assembly as shown in figure 6-11. This adjustment provides the proper tension on the link to eliminate lost motion.
8. Connect link 2 to the flapper assembly.
9. Remove the tape from the process pointer and reconnect link 1 to the Bourdon tube.
10. Perform the controller calibration procedures and, if necessary, the appropriate remote set point calibration procedure in Section 3, 4, or 5.

Replacing Bourdon Tube Controller Link 3

1. Remove the two screws (key 6), and lift off the proportional band indicator cover (key 36).
2. Disconnect link 3 from the set point indicator and the set point beam assembly (key 23).
3. Adjust the replacement link to the same length as the link removed.
4. Install the replacement link with the screw head toward the set point beam assembly as shown in figure 6-13.
5. Check that the set point beam bias spring (key 28) is correctly located in the frame bore and the spring seat on the set point beam assembly as shown in figure 6-3.
6. Move the set point indicator to the mid-scale mark on the process scale.
7. Apply process pressure to position the process pointer at the mid-scale mark on the process scale.
8. Adjust the proportional band to 5 percent DIRECT. Turn flapper leveling screw 3 (the screw nearest the nozzle) until the nozzle just touches the flapper.
9. Adjust the proportional band to 5 percent REVERSE. Turn flapper leveling screw 1 (the screw nearest the nozzle) until the nozzle just touches the flapper.
10. Flapper leveling screws 1 and 3 should protrude the same distance from the clinch nuts. A clinch nut is shown in figure 6-16.

Figure 6-16. Flapper leveling Screw and Clinch Nut

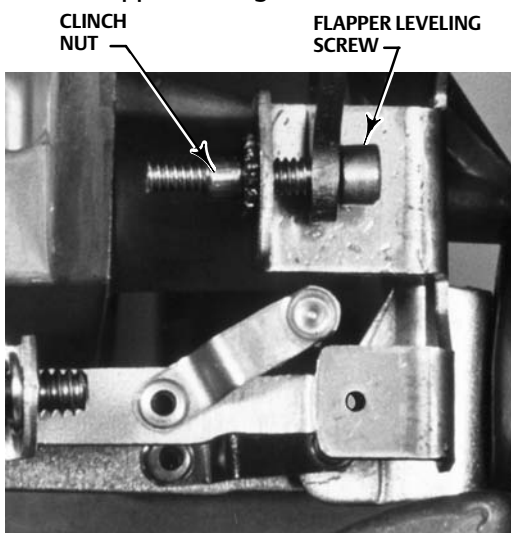

W4191-1

11. If leveling screw 1 protrudes further than leveling screw 3, turn the link 3 adjusting screw counterclockwise. If leveling screw 3 protrudes further than leveling screw 1, turn the link 3 adjusting screw clockwise.

12. Repeat steps 8 through 11 until leveling screws 1 and 3 protrude an equal distance from the clinch nuts.
13. Perform the controller calibration procedures and, if necessary, the appropriate remote set point calibration procedure in Section 3, 4, or 5.

Replacing Bourdon Tube Controller Link 4

1. Remove the two screws (key 6), and lift off the proportional band indicator cover (key 36).
2. Disconnect link 4 from the bellows bracket (key 31) and the flapper assembly (key 11).
3. Connect the replacement link to the flapper assembly so that the two adjusting screws on the link are nearest to the bellows bracket (key 31) and so that the screw heads are facing the bottom of the controller as shown in figure 6-17.

Figure 6-17. Position of Link 4 Adjustment Screws

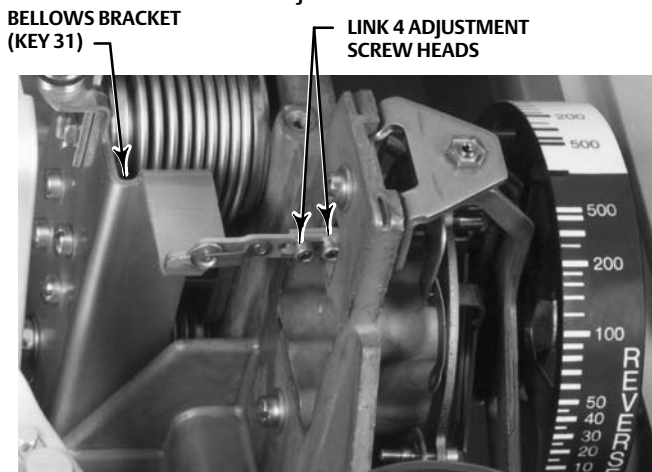

W4195

4. For controllers with reset (4195KB) or reset and rate adjustments (4195KC), turn the reset adjustment to the CLOSED (4195KB) or OFF (4195KC) position. Turn the rate adjustment (4195KC) to the OFF position.

The controller output must be 0 bar (0 psig). To be sure the controller output is at 0 bar (0 psig), remove supply pressure, set the reset adjustment to 0.01 minutes per repeat and wait 30 seconds; then, turn the reset adjustment to the CLOSED (4195KB) or OFF (4195KC) position.

5. Adjust the proportional band to 5 percent REVERSE and move the set point indicator to the process scale upper limit.
6. Disconnect link 1 from the Bourdon tube and move the process pointer to the process scale lower limit. Tape the process pointer in this position.
7. Apply the correct supply pressure to the controller. The output of the controller should be within 0.14 bar (2 psig) of the supply pressure. If not, adjust flapper leveling screw 1 (the screw nearest the nozzle) until the output is within 0.14 bar (2 psig) of supply pressure.
8. Loosen the two adjusting screws on link 4. Connect the free end of the link to the bellows bracket and allow the link to find its free length.
9. Tighten the two adjusting screws on the link.
10. Raise link 4 out of the hole in the bellows bracket (key 31) and ensure that it drops back into the hole under its own weight. If not, repeat steps 8 and 9.
11. For a controller with reset, adjust the reset adjustment to 0.01 minutes per repeat. The rate adjustment (4195KC) should remain in the OFF position.
12. The controller output should be within 0.14 bar (2 psig) of the supply pressure. If not, adjust flapper leveling screw 1 (the screw nearest the nozzle) until the output is within 0.14 bar (2 psig) of supply pressure.

13. Remove the tape from the process pointer and connect link 1 to the Bourdon tube.
14. Perform the controller calibration procedures and, if necessary, the appropriate remote set point calibration procedure in Section 3, 4, or 5.

Bourdon Tube Travel Stop Installation and Adjustment

▲ WARNING

Refer to the Maintenance WARNING on page 51.

Note

The process indicator should be calibrated before installing or adjusting travel stops. Refer to the appropriate process indicator zero and span calibration procedure in Section 3, 4, or 5.

Refer to figure 6-18 for adjustment locations and figure 7-1 for key number locations.

The lower travel stop is necessary only if the operating range lower limit is greater than 0 bar or 0 psig (elevated zero). For example: The process scale limits may be 0 to 300 psig, but the range of operation is 150 to 300 psig. In this example the elevated zero is 150 psig and the lower travel stop would be adjusted for 5 percent of the process scale span less than 150 psig ($150 - (0.05 \times 300) = 135$ psig).

1. Remove the two screws (key 6), and lift off the proportional band indicator cover (key 36).
2. Set the proportional band between DIRECT and REVERSE.
3. Install the upper travel stop (key 73) or upper and lower travel stops (keys 73 and 74) with the machine screws (keys 75 and 76). Do not tighten the machine screws (key 75) that secure the upper travel stop. If only the upper travel stop is installed, go to step 10. Otherwise proceed with step 4.
4. If the operating range lower limit is 0 bar (0 psig), and a lower travel stop is installed, adjust the lower travel stop adjustment so it does not interfere with the Bourdon tube. Tighten the lower travel stop adjustment lock nut and proceed to step 10. If the operating range lower limit is other than 0 psig (elevated zero), perform steps 5 through 15.
5. If the process scale lower limit is other than 0 psig, adjust the process pressure to 5 percent of the process scale span less than the operating range lower limit (see example at the beginning of this procedure).
6. Adjust the lower travel stop adjustment (shown in figure 6-18) until it touches the Bourdon tube.
7. Tighten the lower travel stop adjustment lock nut.
8. Increase the process pressure to the operating range lower limit.
9. The Bourdon tube should not touch the lower travel stop. If it does, repeat steps 5 through 8.
10. Apply process pressure to the controller equal to 105 percent of the process scale span.
11. Slide the upper travel stop (key 73) until it touches the Bourdon tube.
12. Tighten the machine screws (key 75).
13. Decrease the process pressure to 100 percent of the process scale span.
14. The Bourdon tube should not touch the upper travel stop. If it does, repeat steps 10 through 13.
15. Adjust the proportional band to 400 percent in the desired action and install the proportional band indicator cover (key 36). Tighten the two screws (key 6).

Figure 6-18. Bourdon Tube Controller Travel Stop Adjustment

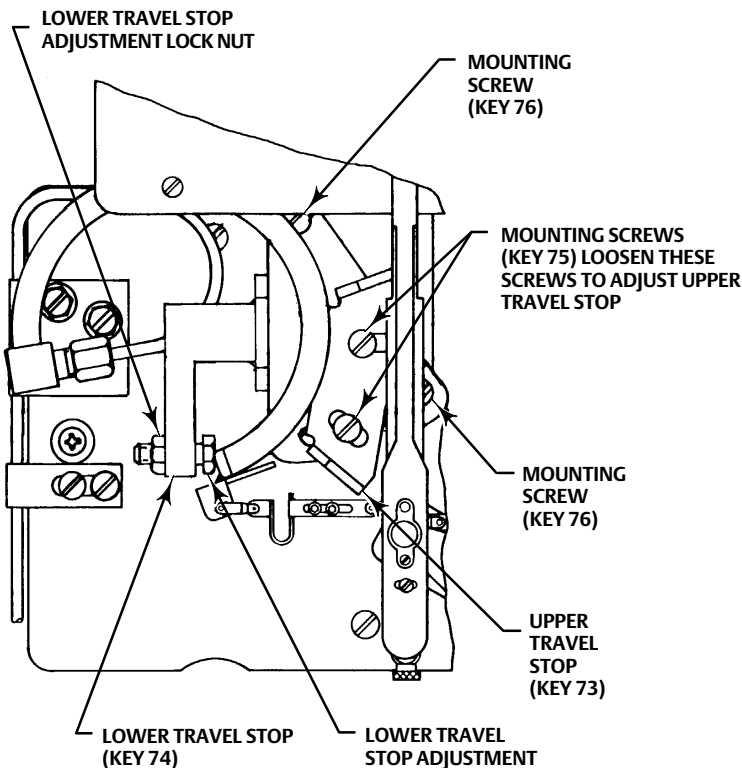

56A9752-U SHT 4
A6945

Bourdon Tube Controller Calibration: Zero and Span Adjustment

⚠ WARNING

Refer to the Maintenance WARNING on page 51.

Note

For routine zero and span calibration, refer to the appropriate procedures in Section 3, 4, or 5. Use the following maintenance zero and span adjustment procedure only if difficulty is encountered with the routine procedure or if nonlinearity occurs.

Refer to figure 6-19 for location of adjustments and figure 7-1 for key number locations.

Provide a means of applying process pressure to the Bourdon tube and a regulated supply pressure adjusted to the normal operating pressure (see table 1-6). For 4195KA and KS controllers, connect the controller output to an accurate gauge. For 4195KB and KC controllers, a gauge is not necessary and the controller output connection may be plugged.

Note

Any adjustment of the process pointer span adjustment screw requires readjustment of the process pointer zero adjustment screw. When checking the zero and span adjustments, ensure that the Bourdon tube does not contact the optional travel stops if used (key 73 and 74).

1. Remove the two screws (key 6), and lift off the proportional band indicator cover (key 36).
2. Set the proportional band adjustment between DIRECT and REVERSE.
3. Set the reset valve (4195KB and KC controllers only) to 0.01 minutes per repeat.
4. Set the rate (4195KC controllers only) to OFF.
5. For a controller with manual set point, move the set point indicator to the mid-scale mark on the process scale. For a controller with remote set point, adjust the remote set point pressure until the set point indicator is at the mid-scale mark on the process scale.
6. Apply process pressure equal to the mid-scale value of the process scale span.
7. The process pointer should be aligned with the pointer subassembly as shown in figure 6-15. If not, loosen the zero adjustment locking screw and adjust the zero adjustment screw to align the process pointer with the pointer subassembly. Tighten the zero adjustment locking screw.
8. The process pointer should indicate mid-scale ± 3 percent of the process scale span. If not, loosen the screws in link 1 and adjust the length so that the process pointer points to the mid-scale mark on the process scale. Tighten the screws.
9. Apply process pressure equal to the process scale lower limit.
10. The process pointer should indicate the process scale lower limit. If not, loosen the zero adjustment locking screw and adjust the zero adjustment screw until the process pointer indicates the lower limit. Tighten the zero adjustment locking screw.
11. Apply process pressure equal to the process scale upper limit.
12. The pointer should indicate the process scale upper limit. If not, proceed as follows:
 - a. If the pointer indicates less than the process scale upper limit, rotate the pointer span adjustment clockwise to increase the span. Adjust the span adjustment screw to correct for half of the error.
 - b. If the pointer indicates greater than the process scale upper limit, rotate the pointer span adjustment counterclockwise to decrease the span. Adjust the span adjustment screw to correct for half of the error.
13. Repeat steps 9 through 12 until the zero and span indications are within ± 1 percent of the scale limits with no further adjustment. If proper span is achieved, proceed to step 15. If the span adjustment screw is adjusted to its limit and the span is still too short or too long, proceed with step 14.
14. Within the process pointer subassembly, there are three holes for the connection of link 1. Use procedure (a.) or (b.) below to make the coarse span adjustment with link 1.
 - a. If the span is short (process pointer indication is less than the process scale upper limit), disconnect link 1 from the process pointer subassembly and move the link to the lowest hole (the hole nearest the pointer pivot). Return to step 9.
 - b. If the span is long, (process pointer indication is greater than the process scale upper limit), disconnect link 1 from the process pointer subassembly and move the link to the highest hole (hole furthest from the pointer pivot), and return to step 9.

Figure 6-19. Fisher 4195K Controller Calibration Adjustment Locations

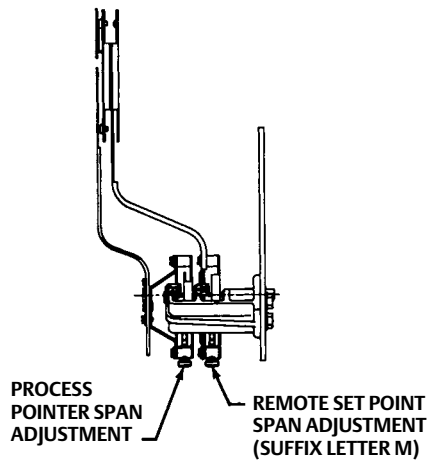
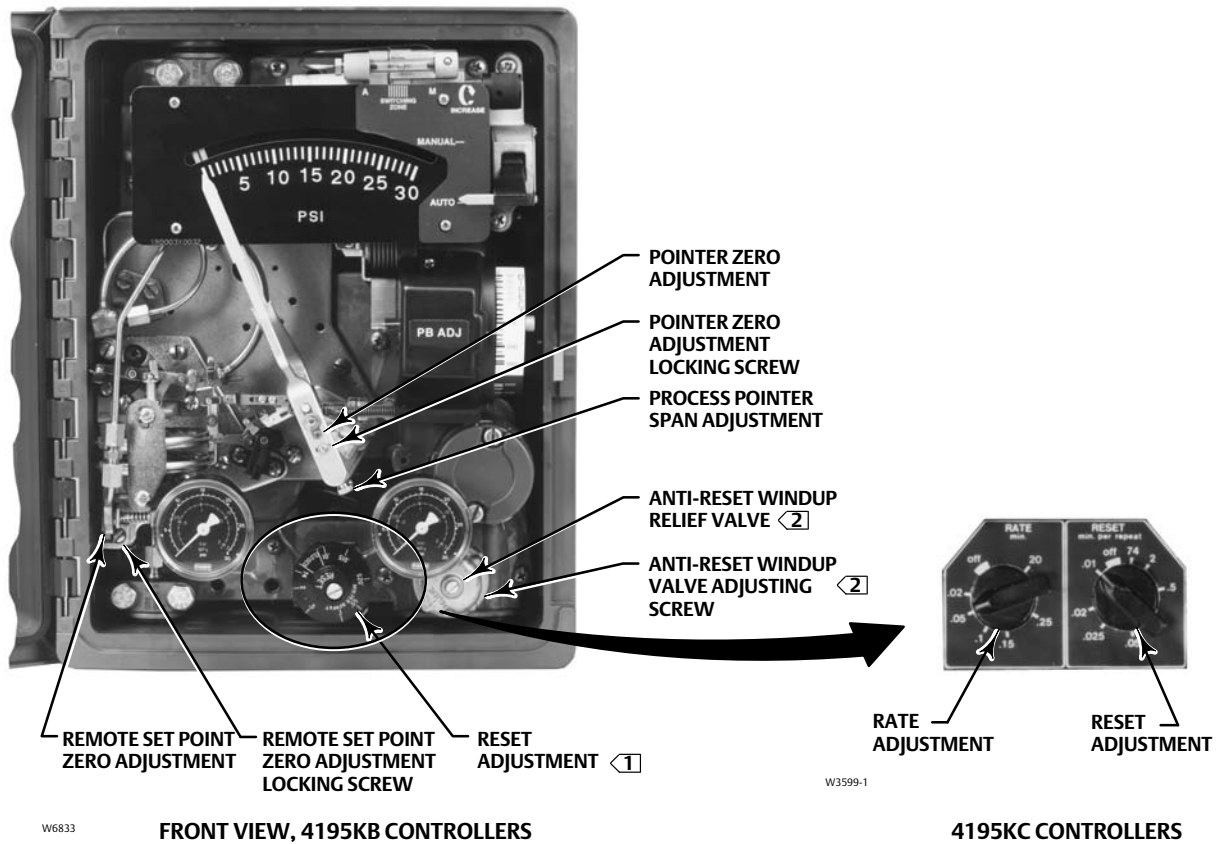

SIDE VIEW OF SET POINT/PROCESS INDICATOR ASSEMBLY

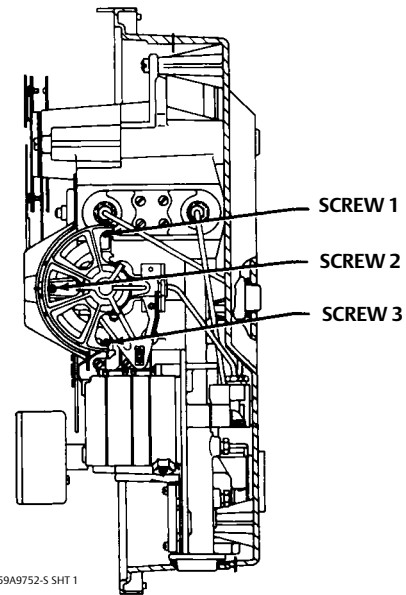

SIDE VIEW OF CONTROLLER SHOWING FLAPPER LEVELING SCREWS

NOTES:
 [1] AVAILABLE ON 4195KB CONTROLLERS ONLY.
 [2] AVAILABLE ON 4195KB AND KC CONTROLLERS SUFFIX LETTER F ONLY.
 39A1126-B
 A6731

15. Apply process pressure equal to the mid-scale value of the process scale span. The process pointer should indicate mid-scale ± 2 percent of the process scale span. If the process pointer error is ± 2 percent or less, proceed to step 17. If the process pointer error is greater than ± 2 percent, loosen the two Bourdon tube mounting screws (key 384, figure 7-2). Also, loosen the two screws (keys 379 and 380, figure 7-2) holding the process tubing retainer.
16. Slide the Bourdon tube up or down and tighten the four screws loosened in step 15. Several tries may be required to determine the direction in which to move the Bourdon tube to obtain the required accuracy. Return to step 5.
17. Adjust the process pointer to within ± 1 percent of the mid-scale mark by loosening the zero adjustment locking screw and adjusting the zero adjustment screw. Tighten the zero adjustment locking screw. This distributes the error over the entire process scale and keeps all points within ± 1 percent of the process scale span.
18. Adjust the process pressure to the lower and upper limits of the process scale span to make sure the process pointer is still within ± 1 percent of the lower and upper scale limits.
19. Perform the flapper alignment procedure and, if necessary, the appropriate remote set point calibration procedure in Section 3, 4, or 5.

Capsular Element Controller Maintenance and Calibration

Replacing the Capsular Element Assembly

⚠ WARNING

Refer to the Maintenance **WARNING** on page 51.

Refer to figure 7-5 for key number locations, unless noted otherwise.

1. Remove process pressure from the controller.
2. Note the hole location and disconnect link 1 (key 90) from the process pointer.
3. Disconnect the process pressure connection union (key 93) from the pedestal assembly (key 81). Use two 5/16-inch hex wrenches.
4. Remove the four machine screws (key 127 in figure 7-3) that attach the capsular element assembly to the indicator assembly (key 101 in figure 7-3).

CAUTION

In the following step, do not lift out the capsular element assembly by holding the capsular element or linkages. These parts may be damaged.

5. Lift out the capsular element assembly by holding the tie bar (key 97), mounting plate (key 77), travel stop (key 83), or pedestal assembly (key 81).
6. Position the replacement capsular element assembly over the mounting screw holes. Install and tighten the mounting screws (key 127 in figure 7-3).
7. Reconnect link 1 (key 90) to the process pointer in the same hole noted in step 2.
8. Reconnect the process pressure connection union (key 93).
9. Apply process pressure to the controller and check for leaks.
10. Perform the capsular element maintenance calibration procedure in this section. Perform the controller calibration procedures and, if necessary, the appropriate remote set point calibration procedure in Section 3, 4, or 5.

Replacing Capsular Element Parts

⚠ WARNING

Refer to the Maintenance WARNING on page 51.

CAUTION

Avoid bending or kinking the drive flexure during the following procedures. Bending or kinking the drive flexure can result in product damage, as well as impaired performance.

Refer to figure 7-5 for capsular element key number locations. Refer to figure 6-19 for adjustment locations and refer to figure 7-4 for indicator assembly (without process sensing element) part locations.

Replacing the Long Pivot Assembly

1. Remove process pressure from the controller.
2. Remove the tie bar (key 97) from the capsular element assembly by removing the mounting screws (key 103).
3. Note the hole position of link 5 (key 88) and disconnect the link from the pivot adjustment arm on the long pivot clevis assembly (key 78).
4. Using an Allen wrench, remove the cap screw and washer (keys 12 and 13) that attach the drive flexure (key 79) to the pivot adjustment arm of the long pivot clevis assembly. Take care not to bend or kink the drive flexure.
5. Remove the two screws (key 102) attaching the long pivot clevis assembly to the mounting plate (key 77).
6. Loosen the screw on the pivot adjustment arm of the replacement pivot clevis assembly, and adjust the arm to the same length as the arm on the pivot assembly being replaced.
7. Attach the replacement pivot clevis assembly to the mounting plate with the two mounting screws (key 102).
8. Loosely connect the drive flexure to the pivot adjustment arm on the new pivot clevis assembly. See figure 6-20. The adjustment arm of the long pivot clevis assembly is connected to a shaft that turns on bushings at each end of the shaft. In the next step, position the shaft so that both bushings “float” inside the bearings and do not rest against the end of either bearing.

Figure 6-20. Cutaway of Long Pivot Clevis Assembly

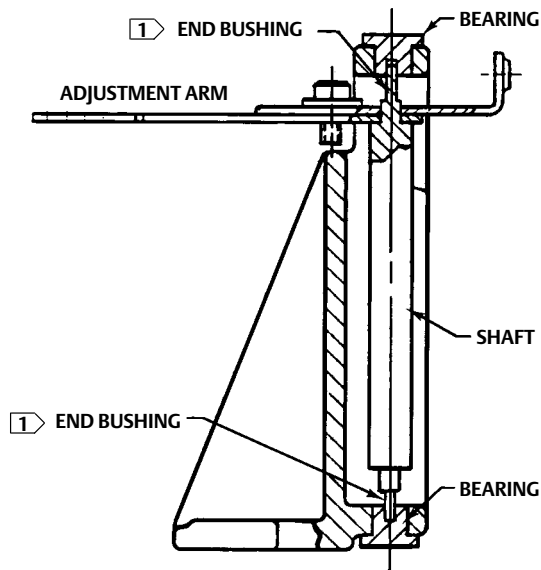

NOTE:
 1 BEFORE TIGHTENING THE DRIVE FLEXURE MOUNTING SCREWS, POSITION THE SHAFT SO THE END BUSHINGS "FLOAT" IN THE BEARINGS.

26A9784-E
 A5682

9. Apply 75 percent of the capsular element range to the capsule. The drive flexure should be straight and horizontal. Before tightening the drive flexure cap screws (key 12), hold the pivot shaft in the middle of the bushing end play. Be sure neither bushing is resting against the inside end of either bearing. Tighten the drive flexure cap screws to hold the pivot shaft in position. Adjust the length of the pivot adjustment arm as needed until the drive flexure is horizontal. Take care not to kink or twist the flexure when tightening the screws.
10. Connect the left-hand end of link 5 (key 88) to the pivot adjustment arm in the hole position noted in step 3.
11. Replace the tie bar (key 97).
12. Perform the capsular element maintenance calibration procedure in this section. Perform the controller calibration procedures and, if necessary, perform the appropriate remote set point calibration procedure in Section 3, 4, or 5.

Replacing the Short Pivot Assembly

1. Remove process pressure from the controller.
2. Note the hole positions of links 1 and 5 (keys 88 and 90) and disconnect the links from the short pivot clevis assembly (key 89). Also, note the screw position of the linearity adjustment for later reference.
3. Remove the two machine screws (key 102) attaching the short pivot clevis assembly (key 89) to the mounting plate (key 77) and remove the pivot clevis assembly.
4. Set the linearity adjustment screw in the replacement pivot assembly to approximately the same location as noted in step 2.
5. Position the replacement short pivot clevis assembly on the mounting plate, and attach it with the two machine screws.
6. Attach links 1 and 5 (keys 88 and 90) in the same hole position as noted in step 2.
7. Perform the capsular element maintenance calibration procedures in this section. Perform the controller calibration procedures and, if necessary, the appropriate remote set point calibration procedure in Section 3, 4, or 5.

Replacing the Process Drive Flexure

1. Set the process pressure to 75 percent of the capsular element range.

2. Remove the tie bar (key 97) from the capsular element assembly by removing the mounting screws (key 103).
3. Using an Allen wrench, remove the cap screws and washers (keys 12 and 13) to disconnect the drive flexure (key 79) from the drive bracket assembly (key 84) and from the pivot adjustment arm of the long pivot clevis assembly (key 78). Remove the drive flexure.
4. Loosely connect the replacement drive flexure, making sure it is straight and horizontal.

Note

See figure 6-20. The adjustment arm of the long pivot clevis assembly is connected to a shaft that turns on bushings at each end of the shaft. In the next step, position the shaft so that both bushings “float” inside the bearings and do not rest against the end of either bearing.

5. Before tightening the drive flexure cap screws (key 12), hold the pivot shaft in the middle of the bushing end play. Be sure neither bushing is resting against the inside end of either bearing. Tighten the drive flexure cap screws to hold the pivot shaft in position. Take care not to kink or twist the flexure when tightening the screws.
6. Perform the capsular element maintenance calibration procedure in this section. Perform the controller calibration procedures and, if necessary, the appropriate remote set point calibration procedure in Section 3, 4, or 5.

Replacing the Process Tubing

1. Remove process pressure from the controller.
2. Using two open-end 5/16-inch wrenches, disconnect the process tubing (keys 91 or 92) at the pedestal assembly (key 81) and at the bottom of the controller case. Remove the tubing.
3. Install the replacement tubing, and tighten all connections. Check for leaks.
4. Perform the controller calibration procedures and, if necessary, the appropriate remote set point calibration procedure in Section 3, 4, or 5.

Replacing Capsular Element Controller Links

⚠ WARNING

Refer to the Maintenance **WARNING** on page 51.

This section describes the separate replacement of five links in the controller. Figure 6-21 shows the location of each link. To clarify the location of each link, the links are numbered as follows:

- Link 1 connects the short pivot clevis assembly and the process pointer
- Link 2 connects the process pointer and the flapper assembly (key 11)
- Link 3 connects the set point indicator and the set point beam assembly (key 23)
- Link 4 (key 65) connects the flapper assembly and the bellows bracket (key 31)
- Link 5 (key 88 in figure 7-5) connects the short pivot clevis assembly (key 89) and the long pivot clevis assembly (key 78).

Figure 6-21. Capsular Element Controller Link Locations and Adjustments

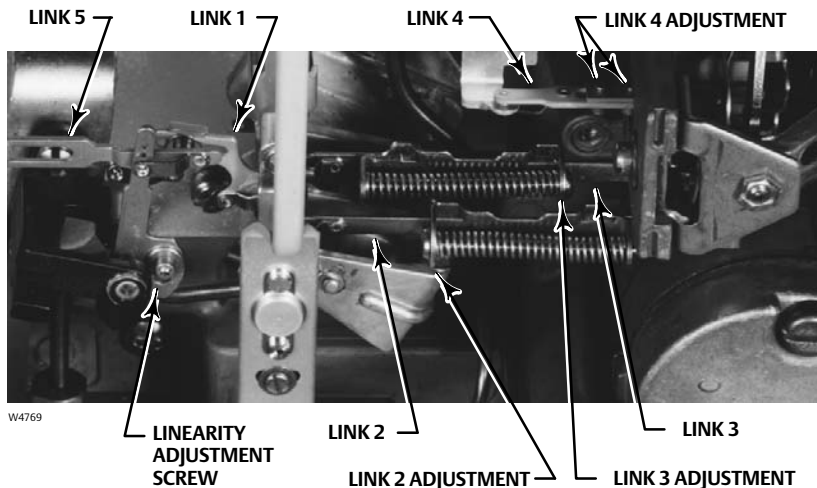

Replacing Capsular Element Controller Link 1

1. Remove the two screws (key 6), and lift off the proportional band indicator cover (key 36).
2. Note the hole position of link 1 and disconnect the link from the short pivot clevis assembly and from the process pointer. Remove the link.
3. Attach the replacement link in the same holes noted in step 2 to the process pointer and the short pivot clevis assembly. If you do not know in which hole in the process pointer the link was connected, place it in the middle hole. If during the process indicator zero and span calibration, the pointer will not travel the full scale, even after full span adjustment, move the link to the bottom hole (the hole nearest the pointer pivot). If the process pointer has too much travel, move the link to the top hole (the hole furthest from the pointer pivot).
4. Move the set point indicator, either manually or with remote set point pressure, to the mid-scale mark on the process scale and set the proportional band between DIRECT and REVERSE.
5. The process pointer should be aligned with the pointer subassembly as shown in figure 6-15. If not, loosen the zero adjustment locking screw and adjust the process pointer zero adjustment to align the process pointer and pointer subassembly. Tighten the zero adjustment locking screw.
6. Apply process pressure equal to the mid-scale value of the process scale span. The process pointer should indicate mid-scale ± 3 percent of the process scale span. If not, loosen the screw in link 1 or link 5, and move the pointer to the mid-scale mark on the process scale. Tighten the screw.
7. Perform the controller calibration procedures and, if necessary, the appropriate remote set point calibration procedure in Section 3, 4, or 5.

Replacing Capsular Element Controller Link 2

1. Remove the two screws (key 6), and lift off the proportional band indicator cover (key 36).
2. Disconnect link 2 from the process pointer and from the flapper assembly (key 11). Remove the link.
3. Install the replacement link with the screw head nearest the process pointer as shown in figure 6-21. Connect the link to the process pointer only.
4. The process pointer should be lined up with the pointer subassembly as shown in figure 6-15. If not, loosen the zero adjustment locking screw and adjust the process pointer zero adjustment to align the pointer with the process pointer subassembly. Tighten the zero adjustment locking screw.

5. Move the set point indicator, manually or with remote set point pressure, to the process scale lower limit and set the proportional band at 5 percent REVERSE. The nozzle should not be touching the flapper. If it is, adjust flapper leveling screw 1 (the screw nearest the nozzle) until clearance is obtained.
6. Note the hole position and disconnect link 1 from the short pivot clevis assembly. Manually position the process pointer to the process scale upper limit and tape the process pointer in this position.
7. Adjust the length of link 2 (by turning the adjusting screw clockwise to increase the length or counterclockwise to decrease the length) so that the pin on the end of the link is approximately one-half of its diameter short of aligning with the hole in the flapper assembly as shown in figure 6-11. This adjustment provides the proper tension on the link to eliminate lost motion.
8. Connect link 2 to the flapper assembly.
9. Remove the tape from the process pointer and reconnect link 1 to the hole in the short pivot clevis assembly noted in step 6.
10. Perform the controller calibration procedures and, if necessary, the appropriate remote set point calibration procedure in Section 3, 4, or 5.

Replacing Capsular Element Controller Link 3

1. Remove the two screws (key 6), and lift off the proportional band indicator cover (key 36).
2. Disconnect link 3 from the set point indicator and the set point beam assembly (key 23).
3. Adjust the replacement link to the same length as the link removed.
4. Install the replacement link with the screw head toward the set point beam assembly as shown in figure 6-21.
5. Check that the set point beam bias spring (key 28) is correctly located in the frame bore and the spring seat on the set point beam assembly as shown in figure 6-3.
6. Move the set point indicator to the mid-scale mark on the process scale.
7. Apply process pressure to position the process pointer at the mid-scale mark on the process scale.
8. Adjust the proportional band to 5 percent DIRECT. Turn flapper leveling screw 3 (the screw nearest the nozzle) until the nozzle just touches the flapper.
9. Adjust the proportional band to 5 percent REVERSE. Turn flapper leveling screw 1 (the screw nearest the nozzle) until the nozzle just touches the flapper.
10. Flapper leveling screws 1 and 3 should protrude the same distance from the clinch nuts. A clinch nut is shown in figure 6-16.
11. If leveling screw 1 protrudes further than leveling screw 3, turn the link 3 adjusting screw counterclockwise. If leveling screw 3 protrudes further than leveling screw 1, turn the link 3 adjusting screw clockwise.
12. Repeat steps 8 through 11 until leveling screws 1 and 3 protrude an equal distance from the clinch nuts.
13. Perform the controller calibration procedures and, if necessary, the appropriate remote set point calibration procedure in Section 3, 4, or 5.

Replacing Capsular Element Controller Link 4

1. Remove the two screws (key 6), and lift off the proportional band indicator cover (key 36).
2. Disconnect link 4 from the bellows bracket (key 31) and the flapper assembly (key 11).
3. Connect the replacement link to the flapper assembly so that the two adjusting screws on the link are nearest to the bellows bracket (key 31) and so that the screw heads are facing the bottom of the controller as shown in figure 6-21.
4. For controllers with reset (4195KB controllers) or reset and rate adjustments (4195KC controllers), turn the reset adjustment to the CLOSED (4195KB) or OFF (4195KC) position. Turn the rate adjustment (4195KC) to the OFF position.

The controller output must be 0 bar (0 psig). To be sure the controller output is at 0 bar (0 psig), remove supply pressure, set the reset adjustment to 0.01 minutes per repeat and wait 30 seconds; then, turn the reset adjustment to the CLOSED (4195KB) or OFF (4195KC) position.

5. Adjust the proportional band to 5 percent REVERSE and move the set point indicator to the process scale upper limit.
6. Disconnect link 1 from the pivot arm. Tape the process pointer to the process scale lower limit (the last mark on the left side of the scale).
7. Apply the correct supply pressure to the controller. The output of the controller should be within 0.14 bar (2 psig) of supply pressure. If not, adjust flapper leveling screw 1 (the screw nearest the nozzle) until the output is within 0.14 bar (2 psig) of supply pressure.
8. Loosen the two adjusting screws on link 4. Connect the free end of the link to the bellows bracket and allow the link to find its free length.
9. Tighten the two adjusting screws on the link.
10. Raise link 4 out of the hole in the bellows bracket (key 31) and ensure that it drops back into the hole under its own weight. If not, repeat steps 8 and 9.
11. For a controller with reset, adjust the reset adjustment to 0.01 minutes per repeat. The rate adjustment (4195KC) should remain in the OFF position.
12. The controller output should be within 0.14 bar (2 psig) of the supply pressure. If not, adjust flapper leveling screw 1 (the screw nearest the nozzle) until the output is within 0.14 bar (2 psig) of supply pressure.
13. Remove the tape from the process pointer and connect link 1 to the pivot arm.
14. Perform the controller calibration procedures and, if necessary, the appropriate remote set point calibration procedure in Section 3, 4, or 5.

Replacing Capsular Element Controller Link 5

1. Remove the two screws (key 6), and lift off the proportional band indicator cover (key 36).
2. Note the location of the connection holes and disconnect both ends of link 5 (key 88) from the lever arms of the two pivot assemblies. Refer to figure 6-22 for parts locations.
3. Loosen the adjustment screw on the replacement link and adjust the length to match the original link. Tighten the adjustment screw.
4. Attach the replacement link to the two lever arms in the same holes noted in step 2.
5. Move the set point indicator, either manually or with remote set point pressure, to the mid-scale mark on the process scale and set the proportional band between DIRECT and REVERSE.
6. The process pointer should be aligned with the pointer subassembly as shown in figure 6-15. If not, loosen the zero adjustment locking screw and adjust the process pointer zero adjustment to align the process pointer and pointer subassembly. Tighten the zero adjustment locking screw.
7. Apply process pressure equal to the mid-scale value of the process scale span. The process pointer should indicate the mid-scale ± 3 percent of the scale span. If not, loosen the screw in link 1 or link 5, and move the process pointer to the mid-scale mark of the process scale span. Tighten the screw.
8. Perform the controller calibration procedures and, if necessary, the appropriate remote set point calibration procedure in Section 3, 4, or 5.

Capsular Element Controller Maintenance Calibration

▲ WARNING

Refer to the Maintenance WARNING on page 51.

Precalibration Procedure

1. Remove the two machine screws (key 6) and lift off the proportional band indicator cover (key 36).
2. Set the proportional band adjustment between DIRECT and REVERSE.
3. Remove the two screws (key 103) and remove the tie bar (key 97) from the capsular element assembly.

Aligning the Drive Bracket Assembly

Refer to figures 6-22 and 7-5.

1. With an Allen wrench, loosen the set screw in the hex nut of the drive bracket assembly (key 84).
2. Loosen the screw (key 98) that holds the guide flexure to the tab on the mounting plate (key 77). The guide flexure location is shown in figure 6-22.

Figure 6-22. Process Input Capsular Element Assembly Part and Adjustment Locations (Positive and Compound Pressure Element Shown)

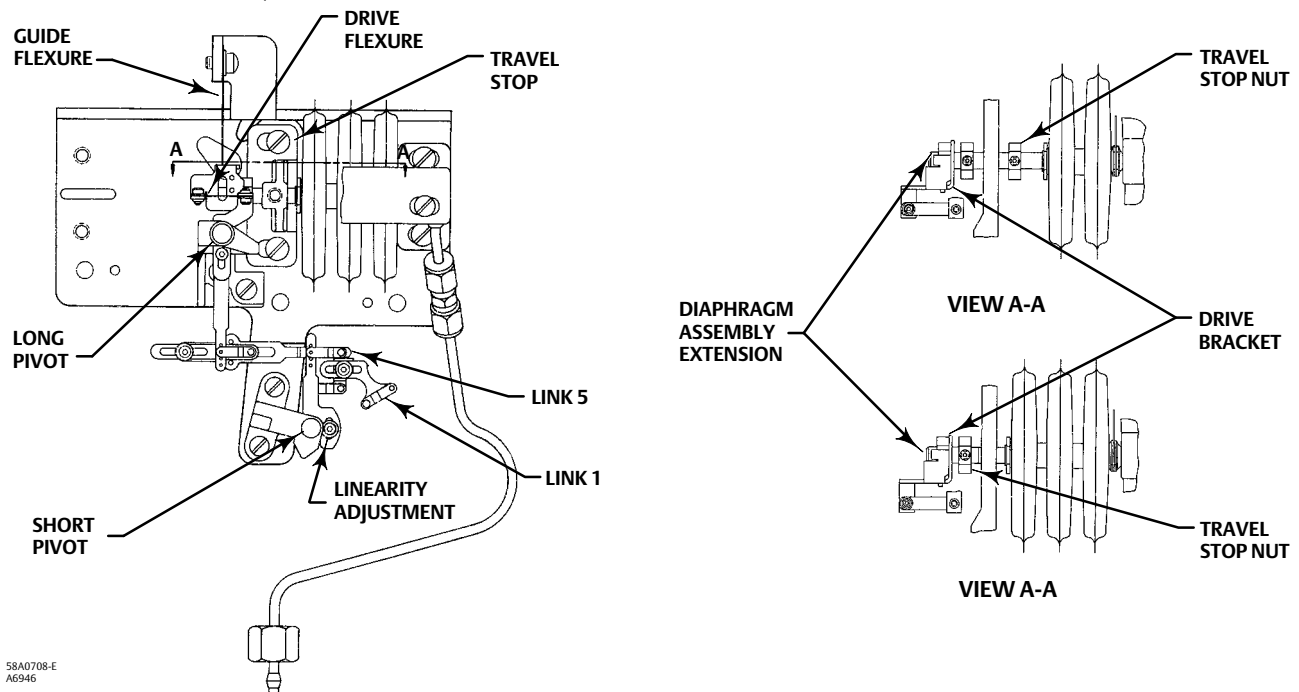

58A0708-E
A6946

3. Apply process pressure equal to 75 percent of the capsular element range.
4. Slide the drive bracket assembly (key 84) along the diaphragm capsule extension (key 82) until the guide flexure is aligned with the center of the long pivot clevis assembly (key 78).
5. Tighten the machine screw (key 98) and the set screw in the hex nut to fasten the drive bracket assembly in that position.

Setting the Capsular Element Travel Stops

1. For the full span stop—Apply process pressure equal to 5 percent greater than capsular element range. Then perform the following as appropriate:
 - For positive or compound pressure with a three-capsule stack, loosen the machine screws (key 139) that secure the travel stop (key 83) to the mounting plate (key 77). Slide the travel stop until it is just touching the end of the

capsule stack. Tighten the travel stop mounting screws to lock it into position. Decrease the input pressure to 100 percent of the capsular element range and make sure the capsule stack is not contacting the travel stop (key 83).

- For positive or compound pressure with a two-capsule stack, loosen the set screw (key 87) in the travel stop nut (key 86) between the travel stop (key 83) and the capsule stack. Slide the nut along the diaphragm capsule extension (key 130) until it just touches the travel stop (key 83). Tighten the set screw to lock the travel stop nut in position. Decrease the input pressure to 100 percent of the capsular element range and make sure the travel stop nut is not contacting the travel stop (key 83).
- For vacuum pressure, loosen the set screw (key 87) in the travel stop nut (key 86) on the end of the diaphragm capsule extension (key 132 or 133). The nut is located on the opposite side of the travel stop (key 83) from the capsule. Slide the nut along the diaphragm capsule extension until it just touches the travel stop (key 83). Tighten the set screw to lock the travel stop nut in position. Decrease the vacuum to 100 percent of the capsular element range and make sure the travel stop nut is not contacting the travel stop (key 83).

2. For the zero stop—perform the following as appropriate:

- If the lower limit of the capsular element range is 0 bar (0 psig), adjust the process pressure to 0 bar (0 psig). Slide the zero travel stop nut (key 86) along the diaphragm assembly extension until it is approximately 0.4 mm (1/64-inch) away from the travel stop. Tighten the set screw to lock the travel stop nut in position.
- If the lower limit of the capsular element range is other than 0 bar (0 psig), adjust the process pressure to 5 percent below the capsular element range lower limit and slide the travel stop nut (key 86) along the diaphragm extension until it just touches the travel stop (key 83). Tighten the set screw. Increase the input pressure to the capsular element range lower limit and make sure the travel stop nut is not contacting the travel stop (key 83).

Aligning the Capsular Element Linkage

1. Adjust the process pressure to 75 percent of the capsular element range. The drive flexure (key 79) should be straight and horizontal. If it is not, proceed as follows:
 - a. Loosen the screw on the pivot adjustment arm on the long pivot clevis assembly (key 78) and the two screws mounting the drive flexure.
 - b. Adjust the length of the pivot adjustment arm so that the drive flexure is parallel to the centerline of the capsules. Tighten the screw to set the length of the pivot adjustment arm in that position.

Note

See figure 6-20. The adjustment arm of the long pivot clevis assembly is connected to a shaft that turns on bushings at each end of the shaft. In the next step, position the shaft so that both bushings “float” inside the bearings and do not rest against the end of either bearing.

- c. Before retightening the drive flexure screws, hold the long pivot clevis assembly shaft in the middle of the bushing end play. Be sure neither bushing is resting against the inside end of either bearing.
 - d. Tighten the drive flexure screws to hold the pivot clevis assembly shaft in position.
2. Set the linearity adjustment screw on the short pivot clevis assembly so the two arms of the short pivot clevis assembly are parallel. The linearity adjustment screw should be near the center of its slot.
 3. Make certain that the process pointer and pointer subassembly are aligned as shown in figure 6-15. If not, loosen the zero adjustment locking screw and adjust the process pointer zero adjustment screw to align the process pointer and pointer subassembly. Tighten the zero adjustment locking screw.
 4. Adjust the process pressure to 50 percent of the capsular element range.

5. Loosen the screw on link 5 (key 88) and adjust the link length so that the pivot arms of the short pivot clevis assembly (key 89) and the long pivot clevis assembly (key 78) are parallel. Tighten the screw.
6. Complete the maintenance calibration by performing the zero and span adjustments in the following procedure.

Capsular Element Controller Zero and Span Adjustment

Note

For routine zero and span calibration, refer to the appropriate procedures in Section 3, 4, or 5. Use the following maintenance zero and span adjustment procedure only if difficulty is encountered with the routine procedure or if nonlinearity occurs.

Provide a means of applying process pressure to the sensing element and a regulated supply pressure adjusted to the normal operating pressure (see table 1-6). Plug the controller output or connect it to a gauge. Monitoring the controller output is not necessary. However, the flapper should not contact the nozzle at any time while performing this procedure. If it does, adjust flapper screw 2 (the one nearest the nozzle) to provide clearance. Refer to figure 6-19 for the adjustment locations. Refer to figure 7-1 for the key number locations.

Note

Any adjustment of the process pointer span adjustment screw requires readjustment of the process pointer zero adjustment screw.

1. Remove the two machine screws (key 6) and lift off the proportional band indicator cover (key 36).
2. Set the proportional band between DIRECT and REVERSE.
3. Adjust the reset (4195KB and KC controllers only) to 0.01 minutes per repeat.
4. Adjust the rate (4195KC controllers only) to OFF.
5. For a controller with manual set point, move the set point indicator to the mid-scale mark on the process scale. For a controller with remote set point, adjust the remote set point pressure until the set point indicator is at the mid-scale mark on the process scale.
6. Apply process pressure equal to the mid-scale value of the process scale span.
7. The process pointer should be aligned with the pointer subassembly as shown in figure 6-15. If not, loosen the zero adjustment locking screw and adjust the zero adjustment screw to align the process pointer with the pointer subassembly. Tighten the zero adjustment locking screw.
8. The process pointer should indicate mid-scale ± 3 percent of the process scale span. If not, loosen the screw on either link 1 or link 5 and adjust the length so that the process pointer points to the mid-scale mark on the process scale. Tighten the screw.
9. Apply process pressure equal to the process scale lower limit.
10. The process pointer should indicate the process scale lower limit. If not, loosen the zero adjustment locking screw and adjust the zero adjustment screw until the process pointer indicates the lower limit. Tighten the zero adjustment locking screw.
11. Apply process pressure equal to the process scale upper limit.
12. The process pointer should indicate the process scale upper limit. If not, proceed as follows:
 - a. If the pointer indicates less than the process scale upper limit, rotate the pointer span adjustment clockwise to increase the span. Adjust the span adjustment screw to correct for one-half of the error.

- b. If the pointer indicates greater than the process scale upper limit, rotate the pointer span adjustment counterclockwise to decrease the span. Adjust the span adjustment screw to correct for one-half of the error.
13. Repeat steps 9 through 12 until the zero and span indications are within ± 1 percent of the scale limits with no further adjustment. If proper span is achieved, proceed to step 16. If the span adjustment screw is adjusted to its limit and the span is still too short or too long, proceed with step 14.
14. Within the process pointer subassembly, there are three holes for the connection of link 1. Use procedure (a.) or (b.) below to make the coarse span adjustment with link 1.
 - a. If the span is short (process pointer indication is less than the process scale upper limit), disconnect link 1 from the process pointer subassembly, move the link to the lowest hole (the hole nearest the pointer pivot), and return to step 9. If the link is already in the lowest hole, proceed to step 15.
 - b. If the span is long, (process pointer indication is greater than the process scale upper limit), disconnect link 1 from the process pointer subassembly, move the link to the highest hole (the hole furthest from the pointer pivot), and return to step 9. If the link is already in the highest hole, proceed to step 15.
15. At either end of link 5, there are four holes in which the link may be connected. A coarse span adjustment can be made by moving both ends of link 5 up or down.
 - a. If the span is short (process pointer indication is less than the process scale upper limit), disconnect both ends of link 5, move the link down one set of holes, and return to step 6.
 - b. If the span is long (process pointer indication is greater than the process scale upper limit), disconnect both ends of link 5, move the link up one set of holes, and return to step 6.
16. Apply process pressure equal to the mid-scale value of the process scale span. The process pointer should indicate mid-scale ± 2 percent of the scale span. If the process pointer error is ± 2 percent or less, proceed to step 17. If the process pointer error exceeds ± 2 percent, the linearity can be improved with the linearity adjustment. See figure 6-22 for the linearity adjustment screw location.
 - a. If the error at mid-scale is high (process pointer is to the right side of the mid-scale mark), loosen the linearity adjustment screw and slide it upward in the curved slot. Tighten the screw and return to step 6.
 - b. If the error at mid-scale is low (process pointer is to the left side of the mid-scale mark), loosen the linearity adjustment screw and slide it downward in the curved slot. Tighten the screw and return to step 6.
17. Adjust the process pointer to within ± 1 percent of the mid-scale mark by loosening the zero adjustment locking screw and adjusting the zero adjustment screw. Tighten the zero adjustment locking screw. This distributes the error over the entire process scale and keeps all points within ± 1 percent of the process scale span.
18. Adjust the process pressure to the lower and upper limits of the scale span to make sure the process pointer is still within ± 1 percent of the lower and upper scale limits.
19. Perform the flapper alignment procedure and, if necessary, the appropriate remote set point calibration procedure in Section 3, 4, or 5.

Remote Set Point (suffix letter M) Maintenance

Replacing the Remote Set Point Assembly

▲ WARNING

Refer to the Maintenance WARNING on page 51.

Use the following procedures to replace the remote set point assembly. Figure 6-23 shows the part locations. Refer to figure 7-6 for key number locations.

Figure 6-23. Remote Set Point (suffix letter M) Parts and Adjustment Locations

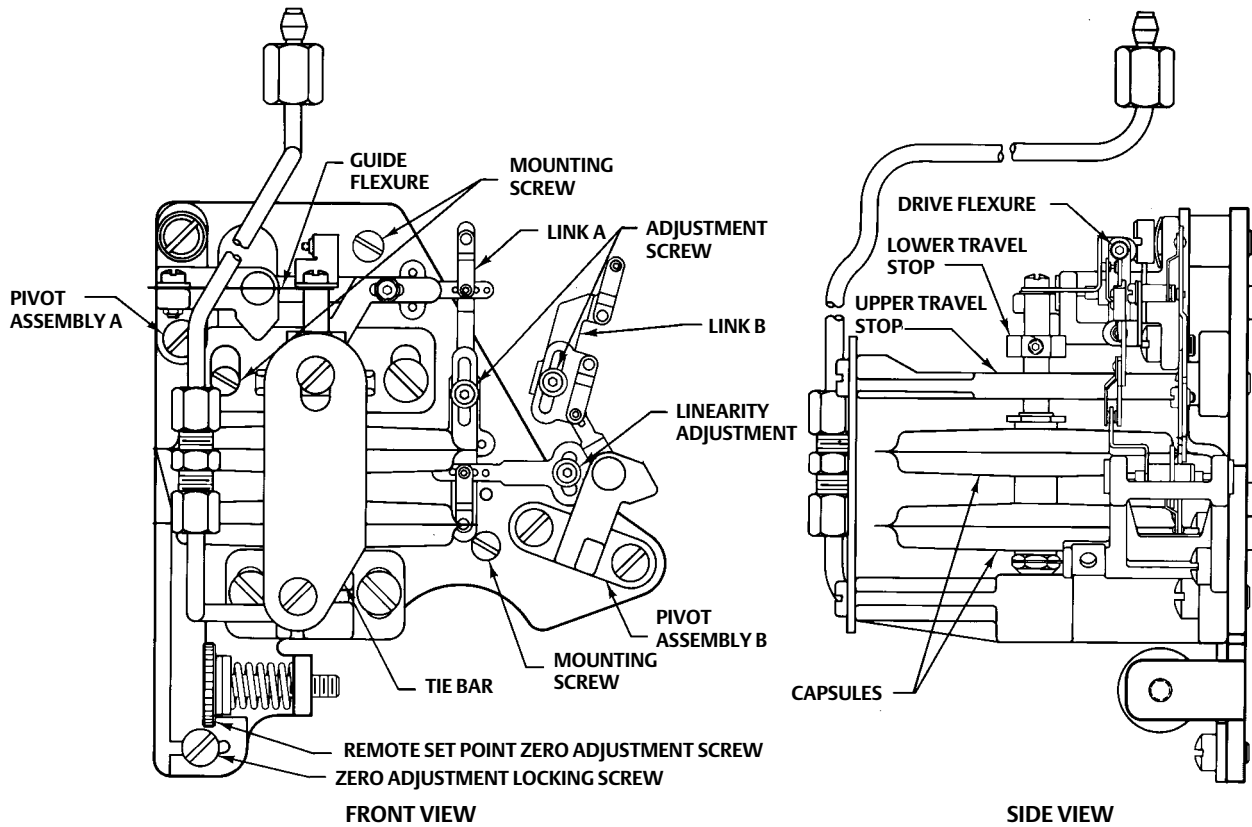

36A9751-C
B1668-4

Note

Remove the supply pressure gauge before attempting to remove the capsular element assembly.

1. Decrease the remote set point pressure to 0 bar (0 psig).
2. Remove the supply pressure gauge.
3. Remove the pressure connection (key 93) at the pedestal assembly (key 105). Use two 5/16 inch wrenches.
4. Disconnect link B (key 126) from the connection hole on the set point indicator.
5. Remove the three mounting screws (keys 120 and 140) that attach the remote set point assembly to the process/set point indicator assembly. Figure 6-23 shows the mounting screw locations.

CAUTION

In the following step, do not lift out the remote set point assembly by holding the capsular element or linkages. These parts may be damaged.

6. Lift out the remote set point assembly by holding the tie bar (key 106), mounting plate (key 111), travel stop (key 83), or pedestal assembly (key 105).
7. Align the replacement assembly with the mounting screw holes. Replace the mounting screws.
8. Reconnect the remote set point pressure connection union (key 93). Apply full remote set point pressure and check for leaks.
9. Connect link B (key 126) to the connecting hole on the set point indicator.
10. Replace the supply pressure gauge.
11. Perform the remote set point maintenance calibration procedure. Perform the appropriate process indicator zero and span calibration and flapper alignment procedure in Section 3, 4, or 5.

Replacing Remote Set Point Assembly Parts

⚠ WARNING

Refer to the Maintenance WARNING on page 51.

CAUTION

Avoid bending or kinking the drive flexure during the following procedures. Bending or kinking the drive flexure can result in product damage, as well as impaired performance.

Figure 6-23 shows the parts and adjustment locations. Refer to figure 7-6 for key number locations.

Replacing Pivot Assembly A (Key 114)

1. Decrease the remote set point pressure to 0 bar (0 psig).
2. Remove the two screws (key 103) and remove the tie bar (key 106).
3. Note where link A is connected. Disconnect link A (key 116) from the lever arm on pivot assembly A (key 114).
4. Disconnect the drive flexure (key 79) from the adjustment arm of pivot assembly A. Be careful not to bend or kink the drive flexure.
5. Remove the screw (key 122), washer (key 123), and nut (key 124) that attach the guide flexure (key 119) to the top of the pivot assembly.
6. Remove the pivot screw and spring washer (keys 109 and 112) and the mounting screw (key 102) attaching the pivot assembly to the mounting plate (key 111). Lift out pivot assembly A.
7. Loosen the adjustment screw (key 118) on the adjustment arm of the replacement pivot assembly, and set the arm to the same length as the arm on the pivot assembly being replaced. Tighten the screw.
8. To replace the pivot assembly, first put the spring washer (key 112) on the screw (key 109). Then, insert the screw through the replacement pivot assembly and into the mounting plate and tighten. Install the mounting screw (key 102) and tighten.
9. Connect the guide flexure (key 119) to the top of the replacement pivot assembly with the screw (key 122), washer (key 123), and nut (key 124) as it was before. The guide flexure should be straight and horizontal as shown in figure 6-23. If not, loosen the screws (key 122) and retighten to eliminate any bowing. Loosen the screws (key 139) and raise or lower the pedestal assembly (key 105) to get the link horizontal. Retighten the screws (key 139) and ensure the diaphragm assembly extension (key 134) is centered in the upper travel stop (key 83) hole.

10. Apply remote set point pressure equal to 50 percent of the remote set point input range.

Note

See figure 6-20. The adjustment arm of the remote set point pivot assembly A turns on a bushing at each end of the shaft supporting the adjustment arm. In the next step, position the shaft so both bushings "float" inside the bearings and do not rest against the end of either bearing.

11. Connect the drive flexure (key 79) to the arm on the replacement pivot assembly, making sure it stays straight and vertical. Adjust the length of the pivot arm, if necessary, until the flexure is vertical. Before tightening the drive flexure screws, hold the pivot assembly shaft in the middle of the bushing end play. Be sure neither bushing is resting against the inside end of either bearing. Tighten the drive flexure screws to hold pivot assembly A in this position. Do not bend or twist the flexure when tightening the screws.
12. Decrease the remote set point pressure to 0 bar (0 psig).
13. Connect the end of link A (key 116) to the pivot lever arm in the same holes noted in step 3.
14. Replace the tie bar (key 106).
15. Perform the remote set point maintenance calibration procedure. Perform the appropriate process indicator zero and span calibration and flapper alignment procedures in Section 3, 4, or 5.

Replacing Pivot Assembly B (Key 115)

1. Decrease the remote set point pressure to 0 bar (0 psig).
2. Note the holes where links A and B are connected. Disconnect links A and B (keys 116 and 126) from the arms of pivot assembly B (key 115).
3. Remove the two screws (key 102) that attach pivot assembly B to the mounting plate (key 111). Remove the pivot assembly.
4. Loosen the linearity adjustment screw on the replacement pivot assembly and set it in the same position as the adjustment on the original pivot assembly. Tighten the screw.
5. Set the replacement pivot assembly on the mounting plate, and attach it with the two machine screws.
6. Attach links A and B (keys 116 and 126) to the arms of the replacement pivot assembly in the same holes noted in step 2.
7. Perform the remote set point maintenance calibration procedure. Perform the appropriate process indicator zero and span calibration and flapper alignment procedures in Section 3, 4, or 5.

Replacing the Drive Flexure

1. Using an Allen wrench, remove the cap screws (key 12) and washers (key 13) to disconnect the drive flexure (key 79) from the drive bracket (key 121) and from the adjustment arm of pivot assembly A. Remove the drive flexure.
2. Set the remote set point pressure to 50 percent of the remote set point input range.

Note

See figure 6-20. The adjustment arm of the remote set point pivot assembly A turns on a bushing at each end of the shaft supporting the adjustment arm. In the next step, position the shaft so both bushings "float" inside the bearings and do not rest against the end of either bearing.

3. Connect the new drive flexure making sure it stays straight and vertical. Adjust the length of the pivot arm, if necessary, until the drive flexure is straight. Before tightening the drive flexure screws, hold the pivot assembly A

shaft in the middle of the bushing end play. Be sure neither bushing is resting against the inside end of either bearing. Tighten the drive flexure screws to hold the pivot shaft in this position. Do not bend or twist the flexure when tightening the screws.

4. Decrease the remote set point pressure to 0 bar (0 psig).
5. Perform the remote set point maintenance calibration procedure. Perform the appropriate process indicator zero and span calibration and flapper alignment procedure in Section 3, 4, or 5.

Replacing the Remote Set Point Tubing

1. Decrease the remote set point pressure to 0 bar (0 psig).
2. Using two 5/16-inch open-end wrenches, disconnect the pressure connection union (key 93) from the pedestal assembly (key 105) and the connection to the case exterior at the top of the case.
3. Remove the tubing (key 104).
4. Install the replacement tubing, and reconnect the two pressure connections.
5. Apply full remote set point pressure, and check for leaks.

Replacing Link A

This procedure describes link A (key 116) replacement in the remote set point assembly. Figure 6-23 shows the link location.

1. Note the holes where link A is connected. Disconnect link A (key 116) from the lever arms on pivot assembly A and pivot assembly B.
2. Loosen the screw in the replacement link A and adjust the length to match the link being replaced. Tighten the screw.
3. Refer to figure 6-23 for the correct link orientation. Attach the replacement link A to the two lever arms in the same holes noted in step 1.
4. Perform the remote set point maintenance calibration procedure. Perform the appropriate process indicator zero and span calibration and flapper alignment procedures in Section 3, 4, or 5.

Replacing Link B

This procedure describes link B (key 126) replacement in the remote set point assembly. Figure 6-23 shows the link location.

1. Note the holes where link B is connected. Disconnect link B (key 126) from the pivot arm and from the set point indicator.
2. Loosen the screw in the replacement link B and adjust the length to match the link being replaced. Tighten the screw.
3. Refer to figure 6-23 for the correct link orientation. Attach the replacement link B to the pivot arm and to the set point indicator in the same holes as noted in step 1.
4. Perform the remote set point maintenance calibration procedure. Perform the appropriate process indicator zero and span calibration and flapper alignment procedures in Section 3, 4, or 5.

Remote Set Point (suffix letter M) Maintenance Calibration

Refer to figure 6-23 for parts and adjustment locations. Refer to figures 7-1 and 7-6 for key number locations.

Precalibration Procedure

⚠ WARNING

Refer to the Maintenance WARNING on page 51.

1. Remove the two screws (key 6) and lift off the proportional band indicator cover (key 36).
2. Set the proportional band adjustment between DIRECT and REVERSE.
3. Remove the two screws (key 103) and remove the tie bar (key 106) from the remote set point assembly.

Aligning the Flexures

▲ WARNING

Refer to the Maintenance WARNING on page 51.

1. Apply remote set point pressure equal to 50 percent of the remote set point pressure range.
2. The guide flexure (key 119) should be straight and horizontal. If not, straighten the flexure by loosening the machine screw (key 122) on the end of the flexure that is attached to the top of the pivot assembly A (key 114) and allow the flexure to straighten itself. Tighten the machine screw.
3. If the flexure is not horizontal, loosen the two machine screws (key 139) and raise or lower the pedestal assembly (key 105) until the guide flexure is horizontal. Retighten the machine screws (key 139) and ensure the diaphragm assembly extension (key 134) is centered in the upper travel stop (key 83) hole.
4. The drive flexure (key 79) should be straight. If not, proceed as follows:
 - a. Loosen the screw (key 118) on the adjustment arm of pivot assembly A (key 114) and loosen the screws holding the drive flexure.
 - b. Set the length of the adjustment arm so that the drive flexure is parallel to the centerline of the diaphragm capsule assembly (key 80).
 - c. Tighten the screw (key 118) on the adjustment arm.

Note

See figure 6-20. The adjustment arm of the remote set point pivot assembly A turns on a bushing at each end of the shaft supporting the adjustment arm. In the next step, position the shaft so both bushings "float" inside the bearings and do not rest against the end of either bearing.

- d. Hold the pivot assembly A shaft in the middle of the bushing end play. Be sure neither bushing is resting against the inside end of either bearing.
- e. Tighten the screws that hold the drive flexure in place.

Setting the Travel Stops

▲ WARNING

Refer to the Maintenance WARNING on page 51.

1. Loosen the set screw (key 87) in the travel stop nut (key 86).

CAUTION

Make sure the loose travel stop nut does not bind on the diaphragm capsule extension (key 134) when pressurizing the capsules (key 80). Damage to the capsules may result.

2. **Full span stop**—Adjust the remote set point pressure to 2-1/2 percent of span greater than the remote set point input range upper limit.

Loosen the two screws (keys 139 and 140) that secure the travel stop (key 83) to the mounting plate (key 111). Slide the travel stop until it is just touching the end of the capsule stack. Tighten the travel stop mounting screws to lock it into position.

3. **Zero Stop**—Adjust the remote set point pressure to 2-1/2 percent of span less than the remote set point input range lower limit.

Slide the travel stop nut (key 86), along the diaphragm capsule extension (key 134) until it is just touching the travel stop (key 83). Tighten the set screw (key 87) to lock the travel stop nut in position.

Aligning the Linkage

⚠ WARNING

Refer to the Maintenance WARNING on page 51.

1. Adjust the remote set point pressure to 50 percent of the remote set point input range.
2. Set the linearity adjustment screw in the center of the slot on the lever arm of pivot clevis assembly B (key 115). See figure 6-23 for the linearity adjustment location.
3. Set the length of link A (key 116) so the lever arms of pivot assembly A and pivot assembly B are parallel and link A is perpendicular to them.
4. Set the length of link B (key 126) so the set point indicator indicates mid-scale on the process scale span.
5. Replace the tie bar (key 106) and install the two screws (key 103).

Remote Set Point Zero and Span Adjustment

⚠ WARNING

Refer to the Maintenance WARNING on page 51.

Note

For routine remote set point zero and span calibration, refer to the appropriate procedures in Section 3, 4, or 5. Use the following maintenance remote set point zero and span adjustment procedures only if difficulty is encountered with the routine procedure or nonlinearity occurs.

Refer to figures 6-19 and 6-23 for adjustment locations.

1. Decrease the remote set point pressure to 0 percent of the remote set point input range.
2. The set point indicator should indicate the lower limit of the process scale span. If not, loosen the adjustment screw on link A (key 116), and adjust the length so the set point indicator points to the lower limit of the process scale. Tighten the screw.
3. Make fine zero adjustments by loosening the zero adjustment locking screw (key 102) and turning the zero adjustment screw (key 108). Tighten the locking screw. Refer to figure 6-23 for the screw locations.
4. Apply remote set point pressure equal to 100 percent of the remote set point input range.
5. The set point indicator should indicate the upper limit of the process scale span.
6. To increase the span, proceed as follows:
 - a. Turn the remote set point span adjustment screw clockwise.
 - b. To increase the span further than the adjustment screw allows, move both ends of link A (key 116) to the right.
 - c. Make fine adjustments with the remote set point span adjustment screw.
7. To decrease the span, proceed as follows:
 - a. Turn the remote set point span adjustment screw counterclockwise.
 - b. To decrease the span further than the adjustment screw allows, move both ends of link A (key 116) to the left.
 - c. Make fine adjustments with the remote set point span adjustment screw.
8. Repeat the adjustments until the upper and lower indications are aligned with the upper and lower limits on the process scale.
9. Adjust the remote set point pressure for 50 percent of the remote set point input range.
10. The set point indicator should indicate mid-scale ± 2 percent of the process scale span. If the error is within ± 2 percent, proceed to step 11. If the error is greater than ± 2 percent of the scale span, proceed to the remote set point linearity adjustment procedure.
11. Adjust the set point indicator to mid-scale ± 1 percent of the process scale span by loosening the zero adjustment locking screw and turning the zero adjustment screw. Tighten the locking screw.
12. Adjust the remote set point pressure to the upper and lower limits of the remote set point input range and make sure the set point indicator is still within ± 1 percent at the lower and upper limits of the process scale.
13. Perform the appropriate flapper alignment procedure and, if necessary, the process indicator zero and span calibration procedure in Section 3, 4, or 5.

Remote Set Point Linearity Adjustment

▲ WARNING

Refer to the Maintenance WARNING on page 51.

Adjust the linearity by loosening and repositioning the linearity adjustment screw in the curved slot on the lever arm of pivot assembly B (key 115). Adjusting the linearity affects the zero and span adjustment.

1. Adjust the remote set point pressure to 50 percent of the remote set point input range. The set point indicator should indicate mid-scale ± 1 percent of the process scale span. If not, make fine adjustments by loosening the zero adjustment locking screw and turning the zero adjustment screw.
2. Adjust the remote set point pressure to 0 percent of the remote set point input range and note the indicator position relative to the process scale lower limit.

3. Adjust the remote set point pressure to 100 percent of the remote set point input range and note the indicator position relative to the process scale upper limit.
4. If the greatest misalignment is positive (the set point indicator is to the right of the process scale limits), loosen the linearity screw and move it clockwise in the slot. If the misalignment is negative, move the linearity screw counterclockwise in the slot.
5. If the misalignment is greater than 1 percent of the process scale span at the lower and upper limits, with one positive and the other negative, perform the remote set point zero and span adjustment procedure to correct a span error.
6. Repeat steps 1 through 4 until lower, middle, and upper indications are within ± 1 percent of the process scale markings.

Auto/Manual Station (suffix letter E) Maintenance

Replacing the Auto/Manual Station

⚠ WARNING

Refer to the Maintenance WARNING on page 51.

Refer to figures 7-1 and 7-7 for key number locations.

Note

This procedure also permits replacement of the switch manifold O-rings (key 312), the auto/manual tubing assembly (key 138), and the frame gaskets (keys 4 and 5).

Disassembly

1. Remove the controller assembly from the case by performing steps 1 through 3 of the case and cover replacement procedure.
2. Loosen the screw (key 316) that holds the auto/manual station (key 273) to the controller frame.
3. Loosen the two screws (keys 314 and 315) that hold the auto/manual station to the auto/manual tubing assembly (key 138).
4. Remove the auto/manual station from the controller frame.
5. Remove the switch manifold O-rings (key 312).
6. Carefully loosen the nut on the relay nozzle tubing assembly (key 18) where it connects to the auto/manual tubing assembly (key 138). Loosen three screws (keys 34 and 131) and remove the tubing assembly and frame gaskets (keys 4 and 5).
7. Inspect the gaskets (keys 4 and 5) and O-rings (key 312) for wear. Replace if necessary.

Assembly

1. Install the gaskets and tubing assembly to the frame. Start, but do not tighten, the three screws (keys 34 and 131) and the nut on the relay nozzle tubing assembly (key 18).
2. Install the switch manifold O-rings (key 312) and secure the auto/manual station to the controller frame with the screw (key 316) and to the tubing assembly (key 138) with the two screws (keys 314 and 315). Do not tighten any screws.

CAUTION

In the next step, take care to tighten the two screws (keys 314 and 315) evenly. Uneven tightening could damage the tubing assembly.

3. Position the auto/manual station as far down on the frame and toward the scale as possible. Carefully tighten the two screws (keys 314 and 315) so that the auto/manual station contacts the three pads on the tubing assembly.
4. Carefully tighten the remaining screws and nuts.
5. Plug the controller output connection and apply supply pressure to the controller. Check for leaks.
6. Position the controller assembly in the case and start, but do not tighten the nine mounting screws. Slide the controller assembly down to assure an O-ring seal at the pressure connections along the bottom of the case. Hold the controller assembly in place while tightening the nine mounting screws.
7. Perform the appropriate calibration procedure in Section 3, 4, or 5.

Replacing the Switch Body Assembly, Lever O-Ring, Switch Body O-Ring, and Tubing Assembly**⚠ WARNING**

Refer to the Maintenance WARNING on page 51.

Refer to figure 7-7 for key number location.

Disassembly

1. Remove the auto/manual station from the controller as described in steps 1 through 4 of the replacing the auto/manual station procedure.
2. Loosen the two screws (key 288) and remove the lever cover plate (key 305).

⚠ WARNING

The lever spring (key 302) is under preload. To avoid personal injury or losing parts, carefully disassemble the auto/manual station.

3. Using a 1/16-inch (1.5 mm) punch, push the groove pin (key 303) out toward the surface of the lever cover plate.
4. Remove the switch lever (key 304), lever spring (key 302), and lever spring seat (key 301).
5. Remove the tubing assembly (key 309).

⚠ WARNING

The switch body springs (key 295) are under preload. To avoid personal injury or losing parts, carefully separate the switch body assembly from the loader assembly.

6. Loosen the two screws (key 290) and separate the switch body assembly (key 291) from the loader assembly (key 282).

7. Remove the O-rings (keys 292, 293, and 294), switch body springs (key 295), and balls (key 296).
8. Loosen two screws (key 308), and remove the closing plate (key 307) and the closing plate gasket (key 306).
9. Pull the clip (key 300) from its engagement with the lever assembly shaft (key 297).
10. Pull the lever assembly from the switch body assembly (key 291) and rocker (key 299).
11. Remove the O-ring (key 298).
12. Inspect the O-rings and gaskets for damage or wear; replace if necessary.

Assembly

1. Insert the lever assembly (key 297) into the switch body assembly (key 291) and hold the rocker (key 299) with the flats on the lever assembly shaft.
2. Insert the clip (key 300) in the groove of the lever assembly shaft to hold the lever assembly (key 297) in the switch body assembly (key 291).
3. Position the closing plate gasket (key 306) and the closing plate (key 307). Secure with two screws (key 308).

Note

After assembly in step 3, be sure the side of the closing plate marked OUT is visible.

4. Place the balls (key 296), switch body springs (key 295), and O-rings (keys 292, 293, and 294) in the switch body assembly (key 291).

Note

In the following step, the ends of the springs must be in the counterbored spring seats before compression.

5. Compress the switch body springs with the loader assembly (key 282), and bolt the switch body assembly (key 291) to the loader assembly with the two screws (key 290).
6. Reconnect the tubing assembly (key 309).
7. Locate the lever spring (key 302) and the spring seat (key 301) on the switch lever (key 304) and position these parts in the opening of the loader assembly (key 282).
8. Push the switch lever down, using the lever spring seat (key 301) and the lever assembly (key 297) to preload the spring. Make sure the notch of the switch lever engages the pin of the lever assembly.
9. Drive in the groove pin (key 303) to hold the switch lever.
10. Replace the lever cover plate (key 305) and attach with two screws (key 288).
11. Perform the assembly portion of the replacing the auto/manual station procedure.

Replacing the Loader Range Spring, Diaphragm Assembly, Ball Seat, Tubing, and Ball

▲ WARNING

Refer to the Maintenance WARNING on page 51.

Refer to figure 7-7 for key number locations.

Disassembly

1. Remove the auto/manual station from the controller as described in steps 1 through 4 of the replacing the auto/manual station procedure.
2. Remove the tubing assembly (key 309).

⚠ WARNING

To avoid personal injury caused by preload from the range spring (key 283), turn the loader knob (key 287) counterclockwise (opposite to the arrow) to relieve pressure on the spring.

3. Loosen the four screws (key 289), and separate the upper loader assembly (key 282) and the lower loader assembly (key 274).
4. Remove the loader range spring (key 283), range spring cup (key 284), and diaphragm assembly (key 281).
5. Remove the tube (key 278), ball seats (key 280) and ball (key 279).

Assembly

1. Turn the loader knob (key 287) counterclockwise to back the spring adjustment screw (key 285) all the way out to eliminate loading the range spring.
2. Position the range spring cup (key 284), range spring (key 283), and the diaphragm assembly (key 281) on the upper loader assembly (key 282).
3. Position the ball (key 279), the tube (key 278), and the ball seats (key 280) between the ears of the loader assemblies (keys 282 and 274); position the diaphragm assembly (key 281) between the main halves of the loader assemblies.

Note

The tube (key 278) must be well seated in the cups of the ball seats (key 280).

4. Bolt the loader assembly halves together using the four screws (key 289).

Note

Be sure that the supply and exhaust seats of the loader are correctly aligned. Misalignment will impair loader performance.

5. Attach the tubing assembly (key 309).
6. Perform the assembly portion of the replacing the auto/manual station procedure.

Replacing the Loader Valve Plug and Valve Plug Spring

⚠ WARNING

Refer to the Maintenance WARNING on page 51.

Refer to figure 7-7 for key number location.

1. Remove the controller assembly from the case by performing steps 1 through 3 of the case and cover replacement procedure.
2. Loosen the spring seat screw (key 275).
3. Remove the valve plug spring (key 276) and the valve plug (key 277).
4. Inspect the parts and replace as necessary.
5. Install the valve plug spring and valve plug.
6. Tighten the spring seat screw.
7. Temporarily apply supply pressure and process pressure and check for leaks.
8. Position the controller assembly in the case and start, but do not tighten the nine mounting screws. Slide the controller assembly down to assure an O-ring seal at the pressure connections along the bottom of the case. Hold the controller assembly in place while tightening the nine mounting screws.
9. Mount the controller as described in the Installation section.
10. Connect the external piping to the controller.

Section 7 Parts

Parts Ordering

Whenever corresponding with your Emerson Process Management sales office about this equipment, always mention the controller serial number. When ordering replacement parts, refer to the 11-character part number of each required part as found in the following parts list.

⚠ WARNING

Use only genuine Fisher replacement parts. Components that are not supplied by Emerson Process Management should not, under any circumstances, be used in any Fisher instrument. Use of components not supplied by Emerson may void your warranty, might adversely affect the performance of the instrument, and could cause personal injury and property damage.

Parts Kits

Description	Part Number
4190 Controller Auto/Manual Repair Kit Contains keys 277, 278, 279, 281, 292, 293, 294, 298, 306, 312	R4190X0AM12
4190 Controller Auto/Manual Retrofit Kit, SST tubing, Contains keys 138, 273, 312, 313, 314, 315, 316	R4190X00S12
4190 Controller Case Handle Kit Contains lever and mounting hardware	R4190X00H12
4190 Controller Repair Kit Contains keys 4, 5, 7, 8, 24, 52	R4190X00C12
4190 Controller Pointer and Bracket Repair Kit Contains pointer and bracket ass'y, three machine screws, three washers	R4190X00P12
4190 Controller Relay Replacement Kit Contains Relay Assembly (includes keys 13 and 15) and key 10	
0.2 to 1.0 bar (3 to 15 psig)	RRELAYX83C2
0.4 to 2.0 bar (6 to 30 psig)	RRELAYX83D2
4195KBF Anti-Reset Windup Retrofit Kit, SST tubing, Contains keys 44 and 55	R4190X00S22

Parts List

Abbreviations Used In Parts List

adj:	adjustment
alt desgntn:	alternative designation
ass'y:	assembly
conn(s):	connection(s)
diff:	differential (as in process differential pressure)
fdback:	feedback
fill hd:	fillister head (as in fillister head cap screw)
ext:	external
hd:	head (as in machine screw head)
int:	internal
OD:	outside diameter
p/o	part of (as in part of another assembly)
pl:	plated (as in plated steel)
pt:	point (as in set point)
qty:	quantity
SST:	stainless steel
w/:	with
w/o:	without

Controller Common Parts (figure 7-1)

Note

Part numbers are shown for recommended spares only. For part numbers not shown, contact your Emerson Process Management sales office.

Note

Figure 7-1 shows key numbers for the common construction of all controller types. Figure 7-1 continues over several pages. Be sure to check all pages of figure 7-1 to find the common key numbers.

Key	Description	Part Number
1	Case and cover ass'y For use w/o remote set pt For use w/remote set pt	
2	Nameplate, A91100 (aluminum)	
3	Frame, A03600 (aluminum)	
4*	Frame gasket, chloroprene For use between frame and frame manifold (key 135)	18A0749X012
5*	Gasket, chloroprene 4195KA, KB, and KS (1 req'd) 4195KC (2 req'd)	18A0742X012
6	Machine screw, fill hd, 18-8 SST (9 req'd) 2 req'd to mount the prop band ind cover to the frame 4 req'd to mount bellows bracket (key 31) to bellows beam (key 49) 2 req'd to attach process scale brackets (keys 376, 377) to frame	
7*	O-Ring, nitrile Used between frame and case at conns: process pressure, either 1/4-18 NPT internal or 1/2-14 NPT external; output and supply; remote set point; and external feedback 3 req'd w/o remote set pt and w/o ext fdback 4 req'd w/remote set pt or ext fdback 5 req'd w/remote set pt and ext fdback	1C376206992
8*	O-Ring, nitrile Used between frame and case on mounting bosses extending from the frame through the back of the case (3 req'd)	16A6903X012
9	Flexure pivot ass'y, sapphire/SST	
10	Machine screw, fill hd, 18-8 SST Used to attach the flexure pivot ass'y (key 9) to the frame (4 req'd)	
11*	Flapper ass'y	29A9518X012
12	Machine screw, hex socket, 18-8 SST For flapper ass'y (key 11) (2 req'd)	
17	Adjustable set pt pivot ass'y, SST	
18	Relay nozzle tubing ass'y, SST	
19	Machine screw, fill hd, 18-8 SST 1 req'd to attach adjustable set pt pivot ass'y (key 17) to frame For 4195KC controllers 3 req'd to attach relay nozzle tubing ass'y (key 18) to frame	

Key	Description	Part Number
20	Plain washer, 18-8 SST Used w/key 19 (2 req'd)	
21	Nozzle ass'y, SST	
22	Washer, plastic (2 req'd)	
23	Set pt beam ass'y, aluminum/SST	
24*	O-ring, nitrile 1 req'd for nozzle tubing ass'y (key 18) 1 req'd for nozzle ass'y (key 21)	1E222606992
25	Proportional band knob, polycarbonate	
26	Retaining clip, S30200 (302 SST)	
27	E-ring, SST	
28	Set pt beam bias spring, pl steel	
29	Set pt beam shoe, G10100 (pl steel)	
30	Machine screw, 18-8 SST Used w/key 29 (2 req'd)	
31	Bellows bracket, A95052 (aluminum)	
32	Bellows adj bracket, G10100 (pl steel)	
33	Bellows adj spring, pl steel	
34	Machine screw, fill hd, 18-8 SST Used to attach frame manifold (key 135) to frame and for reset gain adjustment (2 req'd)	
35	Machine screw, hex hd, 18-8 SST Used to attach bellows bracket (key 31) to each bellows ass'y (key 48) (2 req'd)	
36	Proportional band indicator cover, ABS w/polyester label	
37	Self-tapping screw, 18-8 SST 4 req'd to attach process scale (key 61) to process scale bracket (key 376)	
38	Self-tapping screw, 18-8 SST Used to attach frame inside case (9 req'd)	
39	Supply gauge tubing ass'y, SST	
40	Proportional tubing ass'y, SST For 4195KA or KB controllers For 4195KC controllers	
41	Plug, S30300 (303 SST) For all 4195KA, KB, and KS controllers (1 req'd) For 4195KC, KCM, KCE, and KCME (2 req'd) For 4195KCF, KCFM, KCFE, and KCFME (1 req'd)	
42	Reset valve tubing ass'y, SST For 4195KB controllers w/o ext feedback, SST	
43	Reset tubing ass'y, SST For all 4195KB controllers For all 4195KC controllers	
44	Relief valve tubing ass'y, SST For 4195KBF, KBFE, KBFM, and KBFME only For 4195KCF, KCFE, KCFM, and KCFME only	
45	Positive Feedback Tubing Assembly, SST For 4195KS controllers only	

Key Description Part Number

Note

One type of pressure gauge is used for both output pressure and supply pressure indication.

46*	Pressure gauge (2 req'd)	See Key 46 table
48*	Bellows ass'y (2 req'd)	
	Brass	16A6953X012
	SST	16A6953X022
49	Bellows beam, A96061 (aluminum)	
	0.2 to 1.0 bar (3 to 15 psig)	
	0.4 to 2.0 bar (6 to 30 psig)	
51	Relief valve cover plate, A03600 (aluminum)	
52*	O-ring, nitrile	1C853806992
	Used w/key 51 (2 req'd)	
53	Machine screw, fill hd, 18-8 SST	
	Used w/key 51 (2 req'd)	
	4195KA, KB, and KS controllers	
	4195KC controllers (7 req'd)	
54	Reset restriction valve (4195KB controllers only)	
55	Differential relief valve	
	For all 4195KB and KC controllers w/suffix letter F, anti-reset windup	
57	Pressure control block, CF8M (316 SST Casting)	
	1/4-18 NPT Internal Process Connection	
	1 req'd for all types w/o remote set pt and w/o ext fdbck, except none required for units with Bourdon tube isolator	
	2 req'd for all types w/remote set pt and w/o ext fdbck, except 1 req'd for units with Bourdon tube isolator	
	2 req'd for all types w/ext fdbck and w/o remote set pt, except 1 req'd for units with Bourdon tube isolator	
	3 req'd for all types w/ext fdbck and w/remote set pt, except 2 req'd for units with Bourdon tube isolator	
	1/2-14 NPT External Process Connection	
	For all types w/o remote set pt and w/o ext fdbck (1 req'd)	
	Pressure control block, CF8M (316 SST Casting)	
	1/4-18 NPT Internal Process Connection	
	1 req'd for all types w/o remote set pt and w/o ext fdbck, except none required for units with Bourdon tube isolator	
	For all types w/remote set pt and w/o ext fdbck	
	For all types w/ext fdbck and w/o remote set pt	
	For all types w/ext fdbck and w/remote set pt	

Key 46* Pressure Gauge⁽¹⁾

RANGE	GAUGE MATERIAL	
	Brass	SST
Dual Scale Gauge		
0 to 30 psig/ 0 to 2 kg/cm ²	11B8577X042	11B8583X032
0 to 60 psig/ 0 to 4 kg/cm ²	11B8577X052	---
Triple Scale Gauge		
0 to 30 psig/ 0 to 200 kPa/ 0 to 2 bar	11B8577X012	11B8583X012
0 to 60 psig/ 0 to 400 kPa/ 0 to 4 bar	11B8577X022	11B8583X022
1. One type of pressure gauge is used for both output pressure and supply pressure indication.		

Key Description

56	Process and set pt indicator ass'y w/sensing element
----	--

Note

Individual indicator ass'y parts are listed in two subsections of this parts list: the Process and Set Point Indicator Assembly (key 56) subsection and the Indicator Assembly (key 101) subsection. Key numbers for individual indicator parts also appear in figures 7-2 and 7-3.

	Process and set pt indicator ass'y w/Bourdon tube sensing element
	Process and set pt indicator ass'y w/capsular element ass'y
58	Cap screw, hex hd, SST 2 req'd for use w/each pressure control block (key 57)
59	Hex reducing nipple, (use only when specified) 1/2 NPT external All ranges up to 0-345 bar (0-5000 psig) Steel SST
60	Reducing adaptor, (use only when specified) 1/2 NPT internal All ranges up to 0-345 bar (0-5000 psig) Steel SST
61	Process scale, aluminum For indicator ass'y (key 101)

* Recommended spare parts

Key	Description
62	Remote set pt ass'y (suffix letter M)
Note	
The part numbers listed for key 62 are for the complete remote set point (suffix letter M) ass'y. Individual assembly parts are listed in the Remote Set Point Assembly subsection of the parts list. Key numbers for individual ass'y parts also appear in figure 7-6.	
	N09902 (Nickel Alloy) 0.8 bar (12 psig) span 1.7 bar (24 psig) span SST 0.8 bar (12 psig) span 1.7 bar (24 psig) span
64	Machine screw, fill hd, 18-8 SST 4 req'd to attach process and set pt indicator ass'y (key 56) to frame
65	Feedback link ass'y, aluminum/brass/SST
71	Machine screw, fill hd, 18-8 SST For all 4195KA, KB, and KS controllers (4 req'd) For all 4195KC controllers (6 req'd)
72	Blowout plug, silicone

Note

Key numbers 73 through 76 are only for use with a 4195K controller with a Bourdon tube element. Travel stops are required when the calibration starting point is greater than 0 psig. Use only when specified.

73	Upper travel stop, G10100 (steel) Use only when specified. See Note above.
74	Lower travel stop, G10100 (steel) Use only when specified. See Note above.
75	Machine screw, fill hd, 18-8 SST Use only when specified. See Note above. If only upper travel stop installed, none req'd If both upper and lower travel stop installed, 2 req'd to mount upper travel stop
76	Machine screw, fill hd, 18-8 SST Use only when specified. See Note above. If only upper travel stop installed, 2 req'd to mount upper travel stop If both upper and lower travel stop installed, 2 req'd to mount lower travel stop
120	Machine screw, fill hd, 18-8 SST 2 req'd to attach remote set pt ass'y (suffix letter M) to indicator ass'y base plate
127	Machine screw, fill hd, 18-8 SST (4 req'd)
131	Machine screw, fill hd, S30400 (304 SST) 2 req'd to attach rate/reset manifold (key 136) to frame manifold (key 135)

Key	Description	Part Number
135	Frame manifold, A03600 (aluminum) For all types except w/suffix letter E, auto/manual station	
136	Rate/reset manifold, A03600 (aluminum) For all types except 4195KC controllers	
137	Rate tubing ass'y (for 4195KC controllers only) SST/aluminum	
138	Auto/manual tubing ass'y Use w/suffix letter E, auto/manual station only SST/aluminum	
140	Machine screw, fill hd, 18-8 SST Used to attach remote set pt ass'y (suffix letter M) to indicator ass'y (key 56)	
162	Machine screw, hex hd, 18-8 SST Used to attach the reset valve (4195KB) or rate/reset valve (4195KC) to the frame For 4195KB and KC controllers only	
262	Rate/reset valve ass'y (for 4195KC controllers only) Brass bellows 0.2 to 1.0 bar (3 to 15 psig) 0.4 to 2.0 bar (6 to 30 psig) SST bellows 0.2 to 1.0 bar (3 to 15 psig) 0.4 to 2.0 bar (6 to 30 psig)	
273	Auto/manual station (suffix letter E)	

Note

The part number listed for key 273 is for the complete auto/manual station (suffix letter E). Individual ass'y parts are listed in the Auto/Manual Station subsection of the parts list. Key numbers for individual ass'y parts also appear in figure 7-7.

310	Lithium grease (not furnished with controller)	
311	Anti-seize sealant (not furnished with controller)	
312*	O-ring, nitrile For all types w/suffix letter E, auto/manual station (3 req'd)	1P8453X0022
313	Auto/Manual Scale, plastic For all types w/suffix letter E, auto/manual station	
314	Machine screw, fill hd, 18-8 SST For all types w/suffix letter E, auto/manual station	
315	Machine screw, fill hd, 18-8 SST For all types w/suffix letter E, auto/manual station	
316	Machine screw, SST For all types w/suffix letter E, auto/manual station	
317	Silicone based lubricant, (not furnished with controller)	
318	Lubricant, silicone, not furnished with controller)	
339	External feedback ass'y, SST tubing For controllers w/Bourdon tube or vacuum capsules For controllers w/positive or w/compound capsules	
362	Spring retaining washer, SST	
365	Washer, 18-8 SST	

Figure 7-1. Controller Assembly Drawings

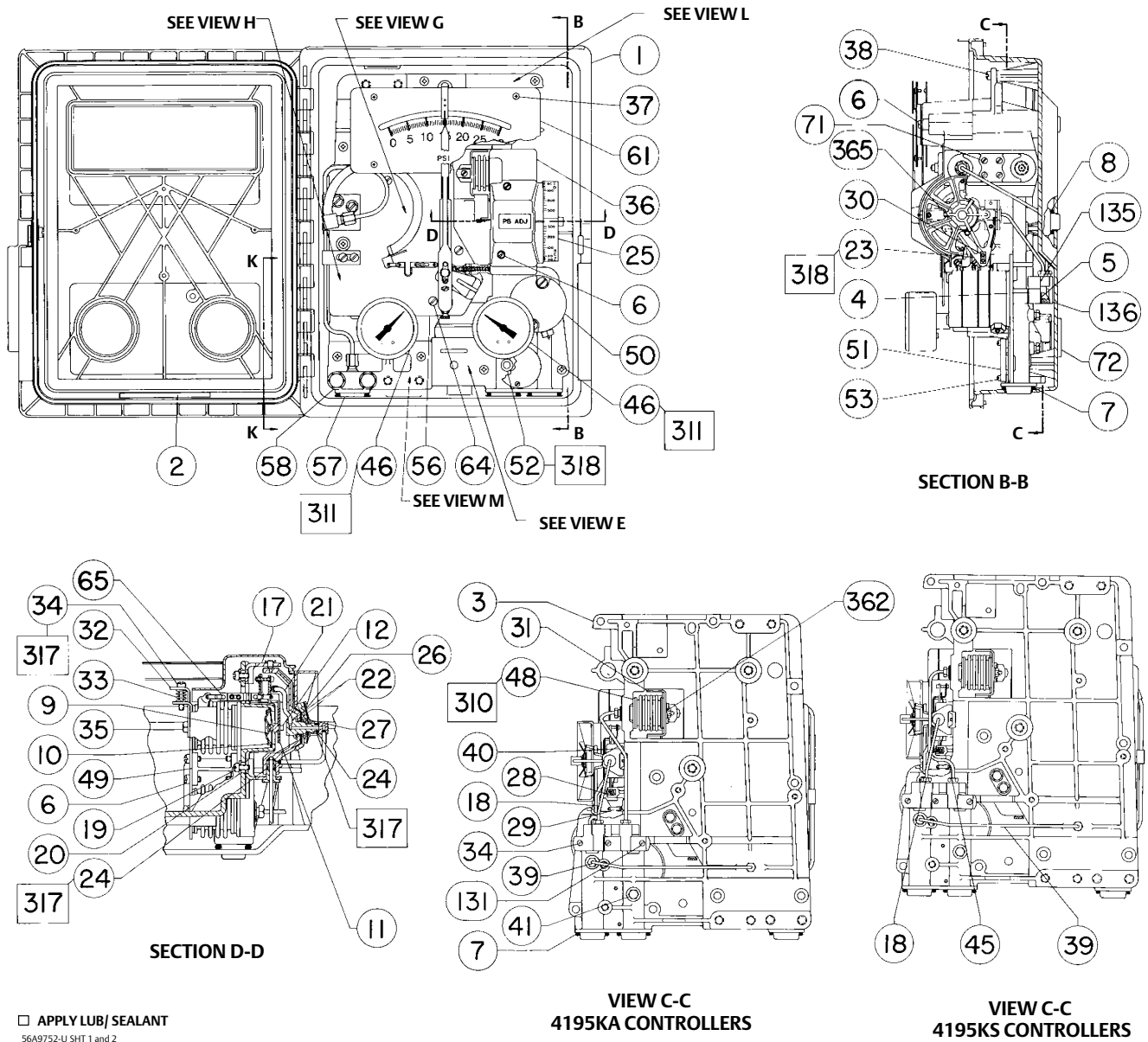

Figure 7-1. Controller Assembly Drawings (cont'd)

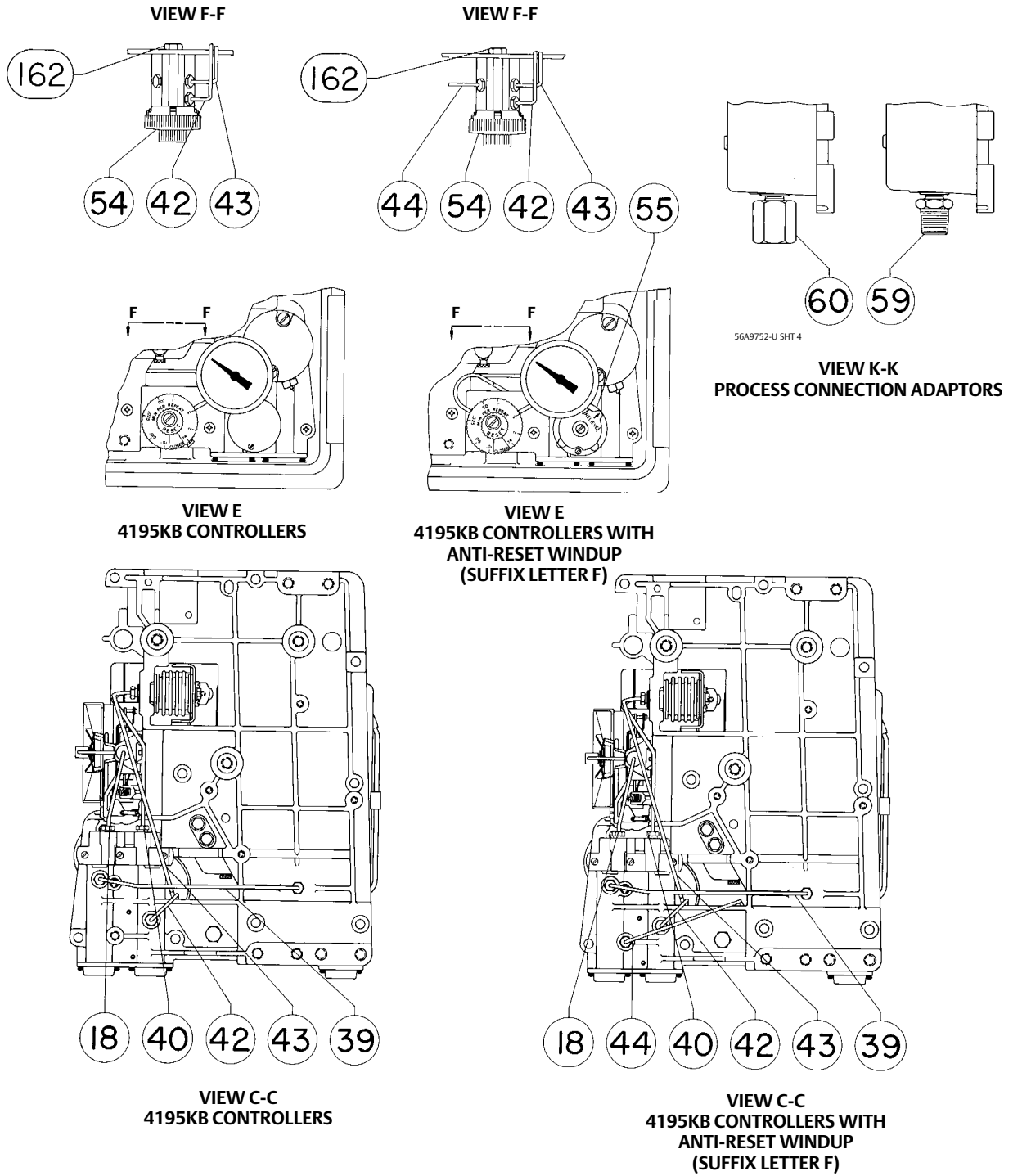
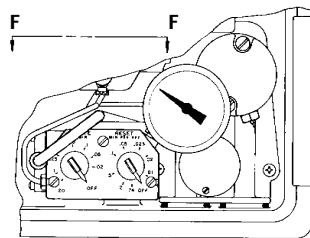
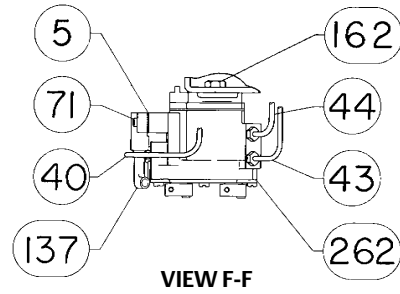
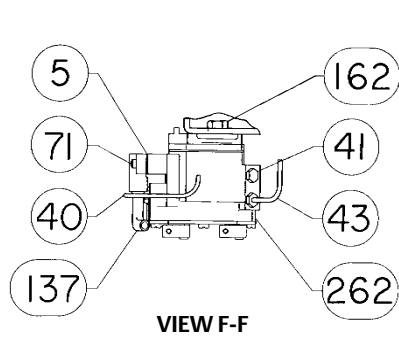
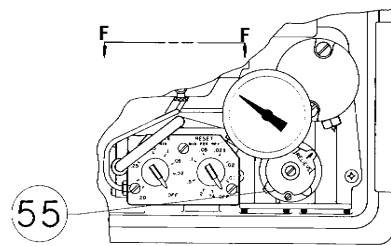

Figure 7-1. Controller Assembly Drawings (cont'd)



4195KC CONTROLLERS



4195KC CONTROLLERS WITH
ANTI-RESET WINDUP (SUFFIX LETTER F)

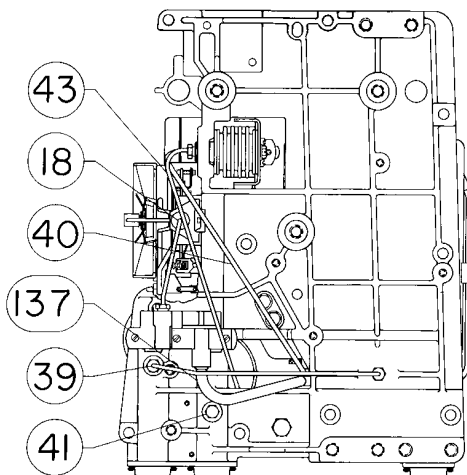

4195KC CONTROLLERS

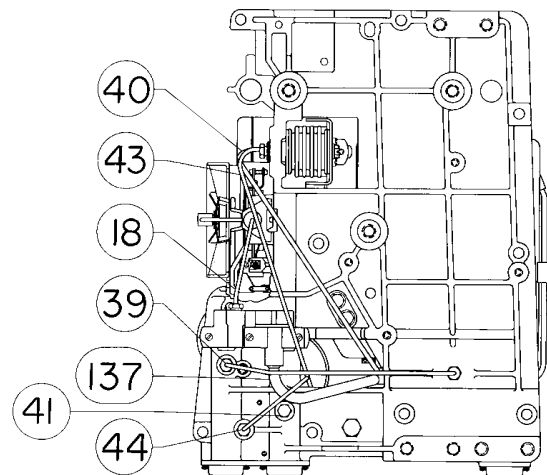

4195KC CONTROLLERS WITH
ANTI-RESET WINDUP (SUFFIX LETTER F)

Figure 7-1. Controller Assembly Drawings (cont'd)

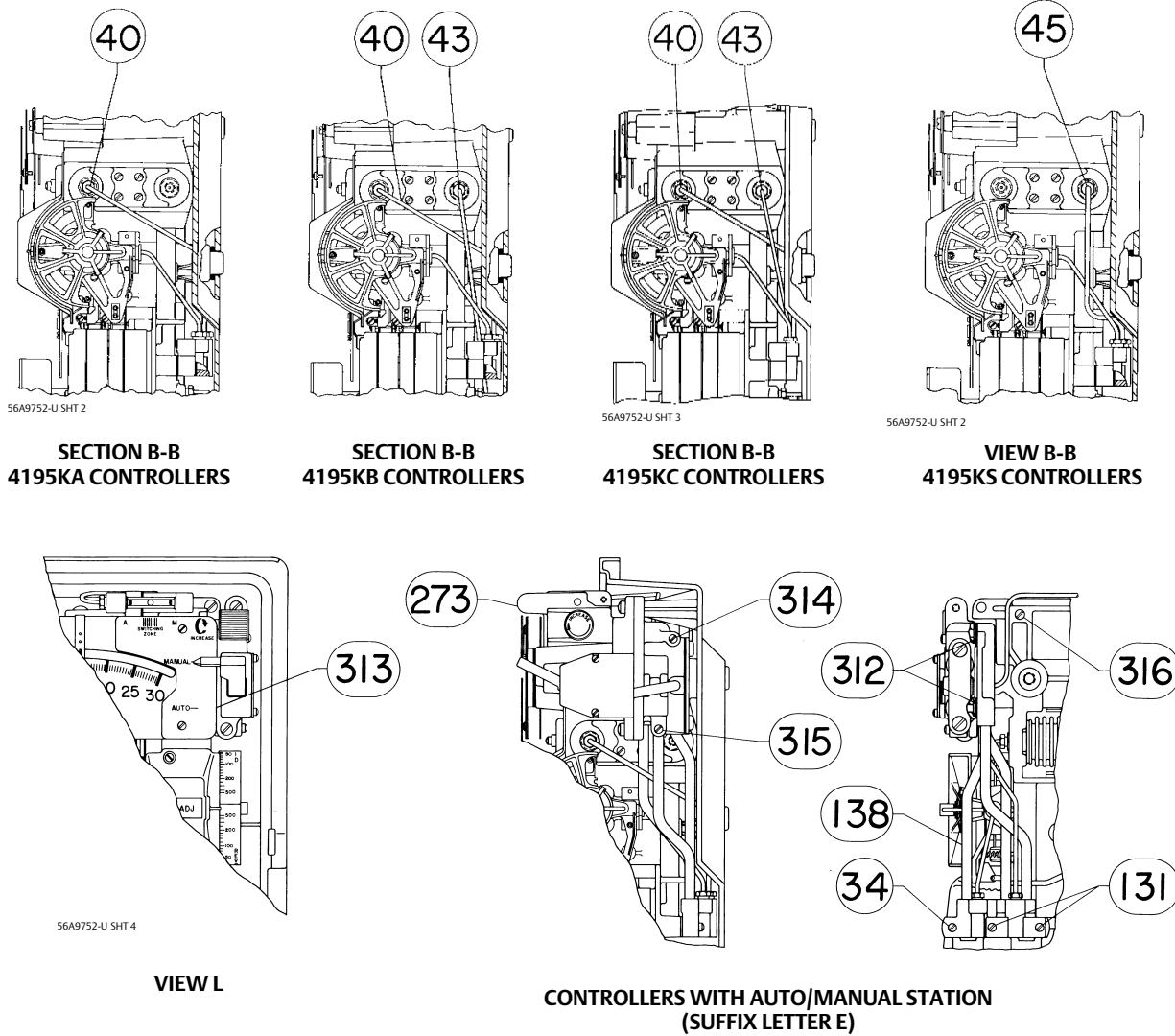
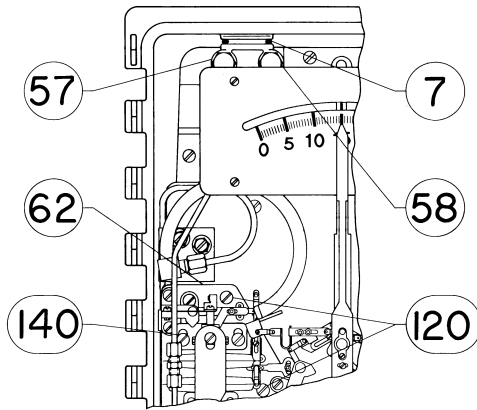
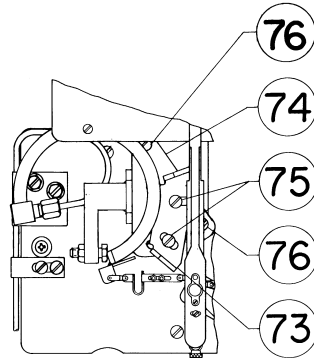

Figure 7-1. Controller Assembly Drawings (cont'd)



56A9752-U SHT 4

VIEW H
CONTROLLERS WITH REMOTE SET POINT
(SUFFIX LETTER M)



VIEW G
BOURDON TUBE
TRAVEL STOPS

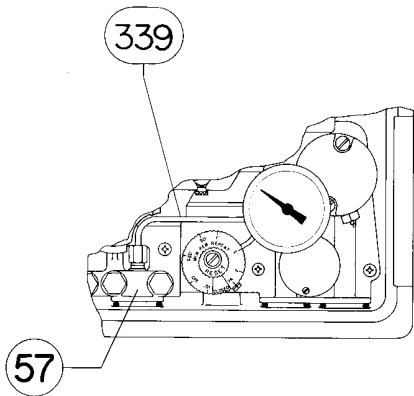

56A9752-U SHT 3

VIEW M
EXTERNAL FEEDBACK FOR
4195K BOURDON TUBE
AND VACUUM PRESSURE CONTROLLERS

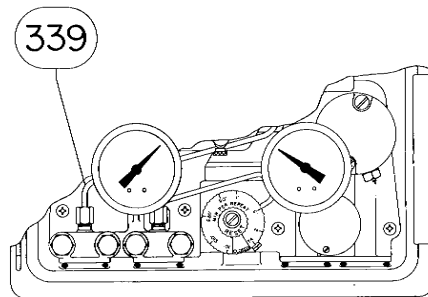

56A9752-U SHT 5

VIEW M
EXTERNAL FEEDBACK FOR
4195K POSITIVE AND
COMPOUND PRESSURE CONTROLLERS

Figure 7-2. Process and Set Point Indicator Assembly for Bourdon Tube Controllers

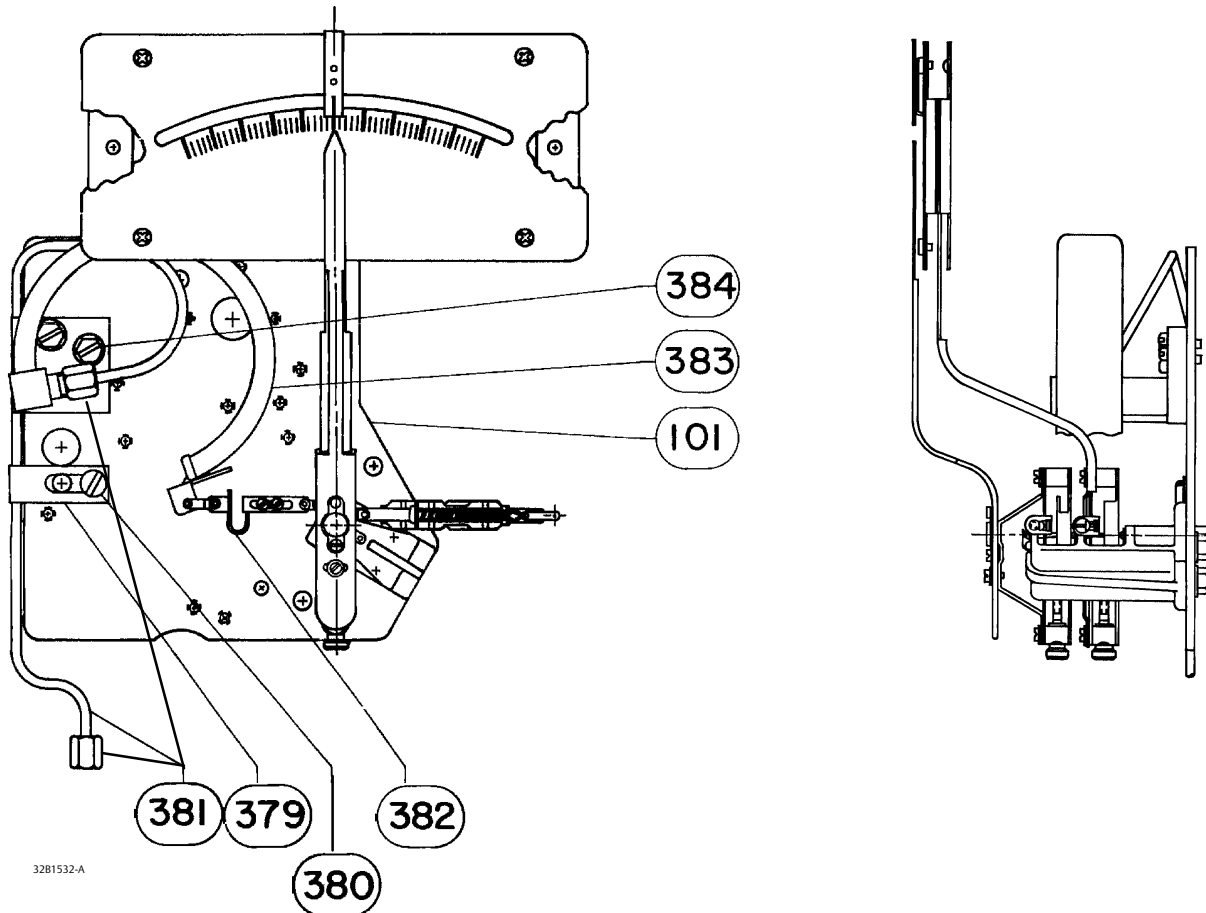

Process and Set Point Indicator Assembly (key 56) (figures 7-2 and 7-3)

Key Description

With capsular element assembly

101 Indicator ass'y

Note

Individual parts are listed in the Indicator Assembly and the Capsular Element Assembly subsections of this parts list. Key numbers for individual ass'y parts also appear in figures 7-4 and 7-5.

Key Description

113 Capsular element ass'y

Note

Individual ass'y parts for key 113 are listed in the Capsular Element Assembly subsection of this parts list. Key numbers for individual ass'y parts also appear in figure 7-4.

For use w/o remote set pt
For use w/remote set pt

127 Machine screw, fill hd, 18-8 SST
4 req'd to attach the capsular element ass'y to the indicator ass'y (key 101)

Figure 7-3. Process and Set Point Indicator Assembly for Capsular Element Controllers (Positive and Compound Pressure Shown)

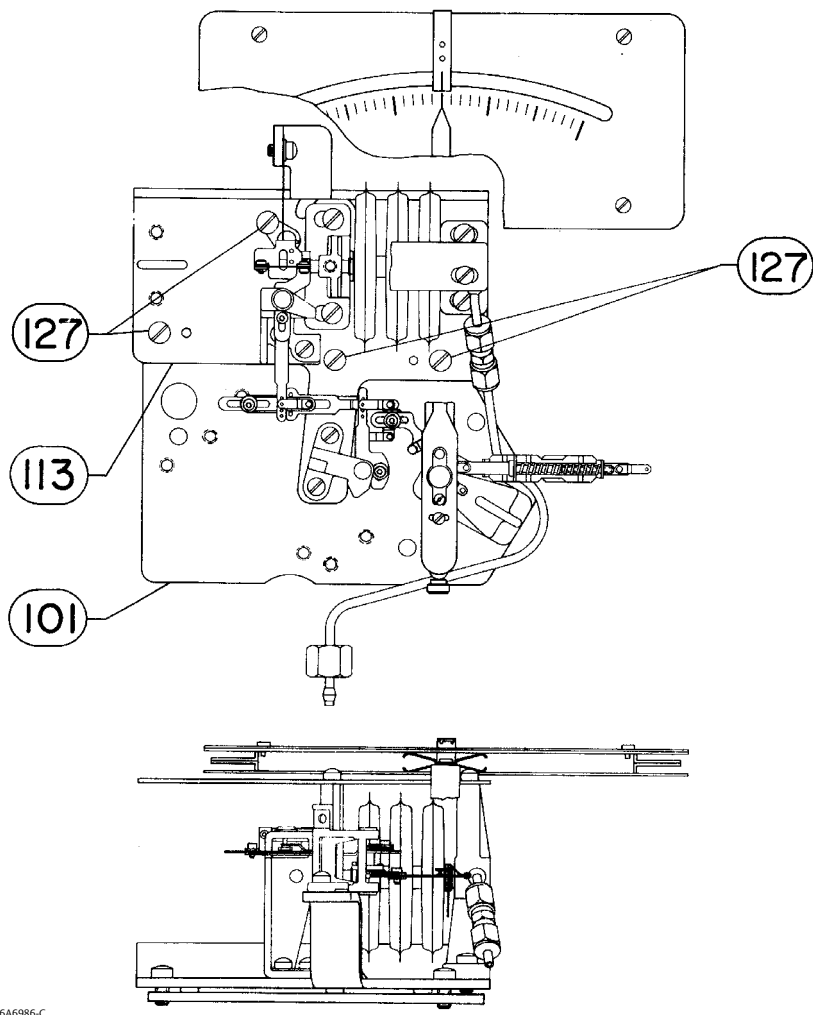

Key	Description	Key	Description	Part Number
With Bourdon tube				
101	Indicator ass'y	379	Process Tube Retainer, S30400 (304 SST)	
		380	Machine screw, pan hd, 18-8 SST	
		381	Process tubing ass'y, SST	
		382	Link ass'y, steel/SST	
		383*	Bourdon tube	See Key 383 table
		384	Screw, self-tapping, pl steel (2 req'd)	

Note
Individual ass'y parts for key 101 are listed in the Indicator Assembly subsection of this parts list. Key numbers for individual ass'y parts also appear in figure 7-4.

For use w/o remote set pt
For use w/remote set pt

Key 383* Bourdon Tubes

BAR RANGE	PSIG RANGE	PART NUMBER
S31600 (316 SST) Bourdon Tube		
0 to 1.6 or 0 to 2	0 to 30	32B4589X012
0 to 4 or 0 to 2.5	0 to 60	32B4589X022
0 to 6	0 to 100	32B4589X032
0 to 10	0 to 200	32B4589X042
0 to 16	0 to 300	32B4589X052
0 to 40 or 0 to 25	0 to 600	32B4589X062
0 to 60	0 to 1000	32B4589X072
0 to 100	0 to 1500	32B4589X082
0 to 160	0 to 3000	32B4589X092
0 to 250 or 0 to 300	0 to 5000	32B4589X102

Indicator Assembly (key 101) (figure 7-4)

Key Description

Note

Key numbers 37, 61, 376, 377, and 378 are not included as part of the indicator assembly (key 101). If replacing the indicator assembly and these parts are required, order them separately.

- 37 Self-tapping screw, 18-8 SST
4 req'd to attach process scale (key 61)
to process scale bracket (key 376)
- 61 Process scale, aluminum See Key 61 tables
- 353 Machine screw, pan hd, 18-8 SST (4 req'd)
- 366 Controller Mounting Plate, 18-8 SST
- 367 Support bracket ass'y, zinc/brass

- Key Description
- 368 Link ass'y, 18-8 SST (2 req'd)
- 369 Process pointer adj ass'y,
aluminum/SST/brass
- 370 Set pt pointer ass'y
aluminum/SST/brass
- 371 Pivot pin, S30200 (302 SST) (2 req'd)
- 372 Washer, plain, 18-8 SST (4 req'd)
- 374 Pointer and bracket ass'y
aluminum/steel
- 375 Set pt indicator ass'y, A93003 (aluminum)
For controllers w/remote set pt
For controllers w/o remote set pt
- 376 Dial Bracket, G10080 (steel)
- 377 Dial bracket, G10080 (steel)
- 378 Screw, self-tapping, 18-8 SST (2 req'd)

Figure 7-4. Indicator Assembly

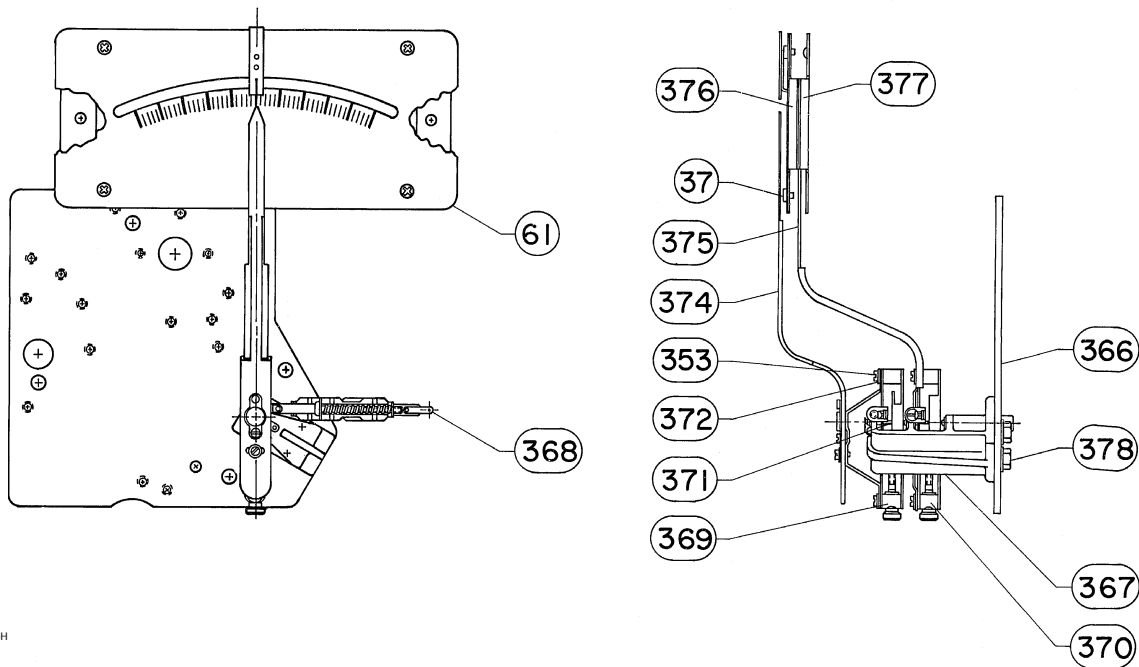

39A1126-H

Key 61 Process Scale, Positive Pressure

Scale Range		Part Number
Bar Scales	0 to 150 mbar	1R0003X1562
	0 to 400 mbar	1R0003X0422
	0 to 0.6	1R0003X0402
	0 to 1	1R0003X0432
	0.2 to 1	1R0003X1602
	0 to 1.4	1R0003X1612
	0 to 1.6	1R0003X0442
	0 to 2	1R0003X1652
	0.4 to 2	1R0003X1622
	0 to 2.5	1R0003X0452
	0 to 4	1R0003X0462
	0 to 6	1R0003X0472
	0 to 10	1R0003X0482
	0 to 16	1R0003X0492
	0 to 25	1R0003X0572
	0 to 40	1R0003X0502
	0 to 60	1R0003X0512
	0 to 100	1R0003X0522
0 to 160	1R0003X0532	
0 to 250	1R0003X0542	
Psig Scales	0 to 60 inch wc	1R0003X0202
	0 to 5	1R0003X0212
	0 to 10	1R0003X0222
	3 to 15	1R0003X0172
	0 to 15	1R0003X0232
	0 to 20	1R0003X0242
	6 to 30	1R0003X0182
	0 to 30	1R0003X0032
	0 to 60	1R0003X0042
	0 to 100	1R0003X0052
	0 to 200	1R0003X0062
	0 to 300	1R0003X0072
	0 to 600	1R0003X0082
	0 to 1000	1R0003X0092
	0 to 1500	1R0003X0102
0 to 3000	1R0003X0112	
0 to 5000	1R0003X0122	
kPa Scales	0 to 200	1R0003X0922
	0 to 400	1R0003X0932
	0 to 700	1R0003X0942
	0 to 1400	1R0003X0702
	0 to 2000	1R0003X0952
	0 to 4000	1R0003X0962
	0 to 7000	1R0003X0972
	0 to 10,000	1R0003X0712
	0 to 20,000	1R0003X0982
	0 to 35,000	1R0003X0992

Key 61 Process Scale, All Controllers

Scale Range	Part Number
0 to 100%	1R0003X1042
0 to 10 Square Root	1R0003X1172
0 to 100 Square Root	1R0003X1292

Key 61 Process Scale, Vacuum and Compound Pressure

SCALE RANGE		PART NUMBER
Vacuum Pressure		
Bar Scales	150 to 0 mbar	1R0003X1632
	400 to 0 mbar	1R0003X0592
	0.6 to 0	1R0003X0602
	1 to 0	1R0003X0612
In Scales	5 to 0	1R0003X0322
	10 to 0	1R0003X0332
	20 to 0	1R0003X0342
	30 to 0	1R0003X0192
Compound Pressure		
Bar Scales	-50 to +100 mbar	1R0003X1572
	-150 to +250 mbar	1R0003X0632
	-0.2 to +0.4	1R0003X0642
	-0.4 to +0.6	1R0003X0652
	-0.6 to +0.8	1R0003X1582
	-1 to +0.6	1R0003X0662
Psig Scales	-1 to +1	1R0003X1592
	30 inches wc vac. to 30 inches wc	1R0003X0252
	5 inches Hg vac. to 2.5 psig	1R0003X0352
	10 inches Hg vac. to 5 psig	1R0003X0362
	15 inches Hg vac. to 7.5 psig	1R0003X0262
	20 inches Hg vac. to 10 psig	1R0003X0372
30 inches Hg vac. to 15 psig	1R0003X0272	

Capsular Element Assembly (key 113) (figure 7-5)

Key	Description
12	Cap screw, hex socket, 18-8 SST (2 req'd)
13	Plain washer, 18-8 SST (2 req'd)
77	Mounting plate, G10100 (pl steel)
78	Long pivot clevis ass'y, plastic/SST
79	Drive flexure, S30200 (302 SST)
80	Diaphragm capsule ass'y
81	Pedestal assembly, SST
82	Diaphragm ass'y extension, A96061 (aluminum) See key 80 table to determine if required
83	Travel stop, CF8 (SST casting)
84	Drive bracket ass'y, SST
86	Travel stop nut, S30300 (303 SST) See key 80 table for quantity
87	Set screw, 18-8 SST 1 req'd for drive bracket ass'y (key 84), 1 req'd for each travel stop nut (key 86)
88	Connecting link ass'y, aluminum/bronze/brass
89	Short pivot clevis ass'y, plastic/SST
90	Connecting link ass'y, aluminum/bronze/brass
91	Process tubing ass'y, S30400 (304 SST) (positive and compound capsule only)
92	Process tubing ass'y, S30400 (304 SST) (vacuum capsule only)
93	Union, S31600 (316 SST)
97	Tie bar, G10100 (pl steel)
98	Machine screw, fill hd, 18-8 SST Used to attach the guide flexure (p/o drive bracket ass'y) to mounting plate
99	Plain washer, 18-8 SST

Key	Description
102	Machine screw, fill hd, 18-8 SST For mounting the short pivot clevis ass'y (key 89) and the long pivot clevis ass'y (key 78) to the mounting plate (key 77) (4 req'd)
103	Machine screw, pan hd, 18-8 SST For mounting tie bar (key 97) to pedestal ass'ies (key 81) and to travel stop (key 83) (2 req'd)
130	Diaphragm ass'y extension, A96061 (aluminum) See key 80 table to determine if required
132	Diaphragm ass'y extension, A96061 (aluminum) See key 80 table to determine if required
133	Diaphragm ass'y extension, A96061 (aluminum) See key 80 table to determine if required
139	Machine screw, fill hd, 18-8 SST 2 req'd to mount each pedestal ass'y (key 81) (4 req'd)

Relay (figure 6-2)

Relay Assembly (includes keys 13 and 15)

0.2 to 1.0 bar (3 to 15 psig)
0.4 to 2.0 bar (6 to 30 psig)

10	Relay mounting screw, 18-8 SST (2 req'd)
13	O-ring, nitrile
15	O-ring, nitrile (2 req'd)

Note

The above relay parts are included in the 4190 Relay Replacement Kit.

Figure 7-5. Capsular Element Assembly

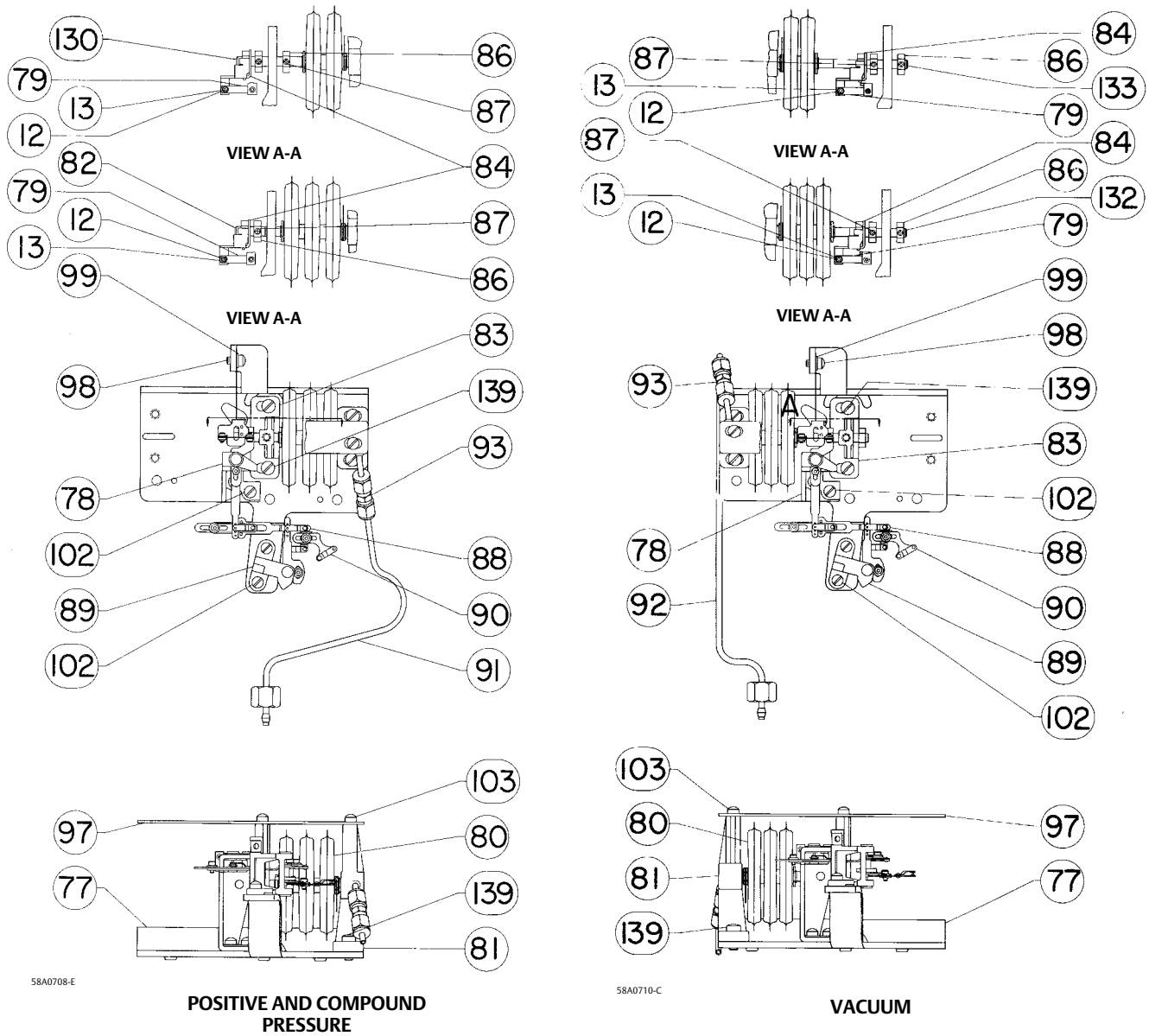

Remote Set Point Assembly (suffix letter M)
(key 62) (figure 7-6)

Key Description

- 12 Cap screw, hex socket, 18-8 SST (2 req'd)
- 13 Plain washer, 18-8 SST (3 req'd)
- 79 Drive flexure, SST

Key Description

- 80 Diaphragm capsule ass'y
1 bar (12 psig) span
N09902 (Nickel Alloy)
SST
- 2 bar (24 psig) span
N09902 (Nickel Alloy)
SST
- 83 Travel stop, CF8 (SST casting)

Figure 7-6. Remote Set Point Assembly

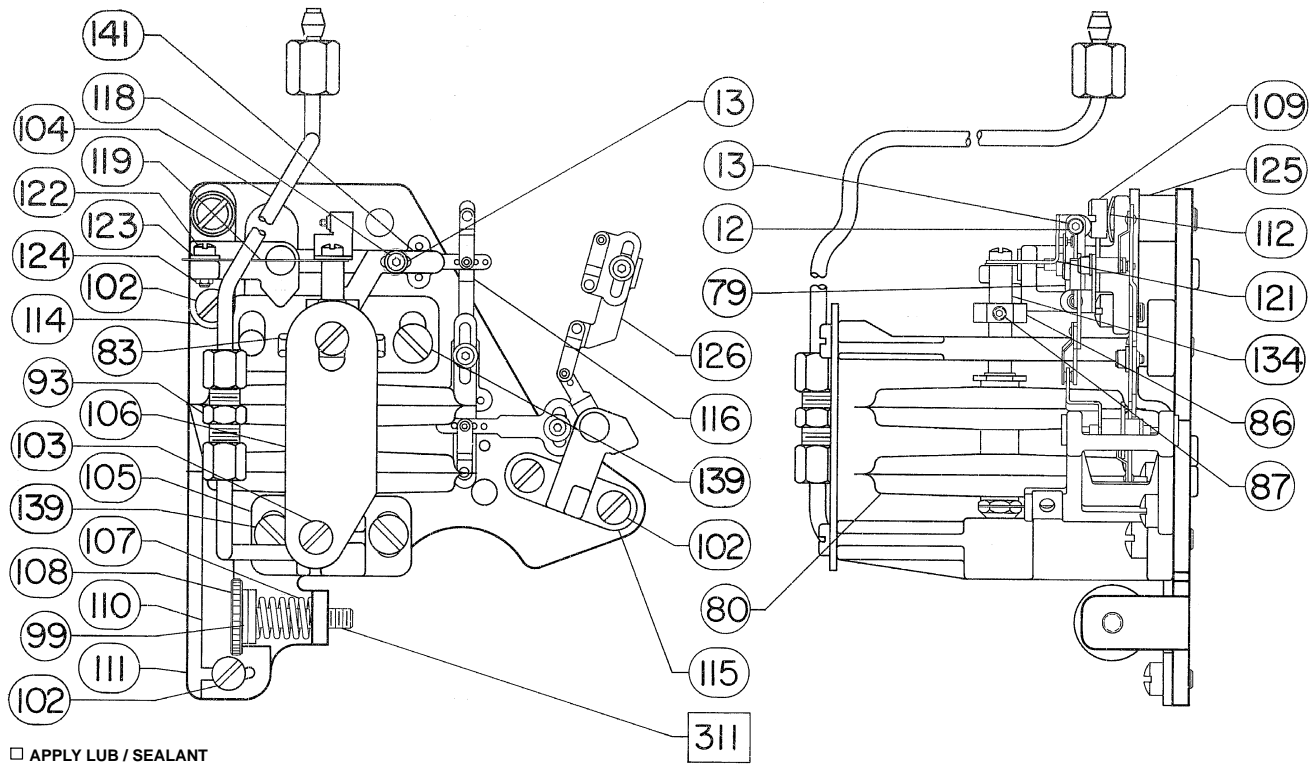

□ APPLY LUB / SEALANT

36A6988-C

Key	Description
86	Travel stop nut, S30300 (303 SST)
87	Set screw, hex socket, 18-8 SST
93	Union, S31600 (316 SST)
99	Plain washer, 18-8 SST
102	Machine screw, fill hd, 18-8 SST (4 req'd)
103	Machine screw, pan hd, 18-8 SST (2 req'd)
104	Remote set pt tubing ass'y, S30400 (304 SST)
105	Pedestal ass'y, SST
106	Tie bar, G10100 (pl steel)
107	Spring, pl steel
108	Zero adj screw, S30300 (303 SST)
109	Pivot screw, S30300 (303 SST)
110	Zero adj bracket, S30400 (304 SST)
111	Mounting plate, G10100 (pl steel)
112	Spring washer, pl steel
114	Pivot clevis ass'y A, plastic/SST
115	Pivot clevis ass'y B, plastic/SST
116	Connecting link ass'y, aluminum/bronze/brass
118	Cap screw, hex socket, 18-8 SST
119	Guide flexure, S30200 (302 SST)
121	Drive bracket, S30400 (304 SST)

Key	Description
122	Machine screw, fill hd, 18-8 SST (2 req'd)
123	Plain washer, 18-8 SST
124	Nut, Hex, 18-8 SST
125	Spacer, A92011 (aluminum)
126	Connecting link ass'y, aluminum/bronze/brass
134	Diaphragm ass'y extension, A92011 (aluminum)
139	Machine screw, fill hd, 18-8 SST (3 req'd)
141	Adj arm, S30400 (304 SST)
311	Anti-seize sealant (not furnished with controller)

Auto/Manual Station (suffix letter E) (figure 7-7)

274	Lower loader ass'y, aluminum
275	Spring seat screw, pl steel
276	Valve plug spring, K08500 (pl steel)
277	Valve plug, 18-8 SST
278	Tube, plastic
279	Ball, SST
280	Ball seat, nitrile (2 req'd)
281	Diaphragm ass'y, nitrile/aluminum
282	Loader ass'y, aluminum/plastic
283	Range spring, SST
284	Range spring cup, pl steel

Figure 7-7. Auto/Manual Station Assembly

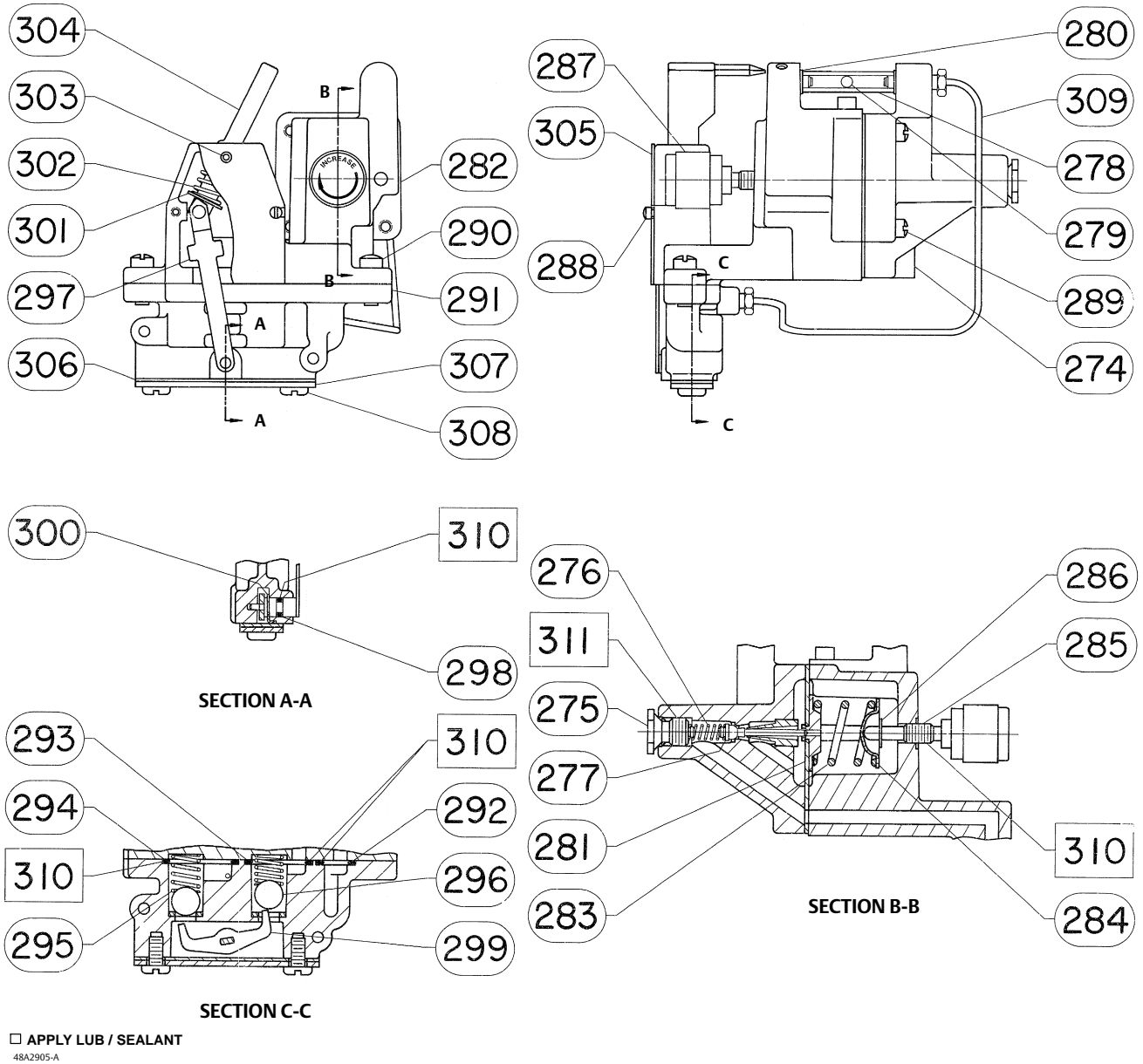

□ APPLY LUB / SEALANT
48A2905-A

Key	Description	Part Number	Key	Description	Part Number
285	Spring adj screw, pl steel		291	Switch body ass'y, aluminum/nitrile	
286*	Retaining ring, pl steel	18A2903X012	292*	O-ring, nitrile	1U2398X0032
287	Loader knob, plastic		293*	O-ring, nitrile	11A8741X052
288	Machine screw, rd hd, 18-8 SST (2 req'd)		294*	O-ring, nitrile	13A1584X012
289	Machine screw, fill hd, 18-8 SST (4 req'd)		295	Switch body spring, K08500 (pl steel) (2 req'd)	
290	Machine screw, fill hd, S30200 (302 SST) (2 req'd)		296	Ball, SST (2 req'd)	
			297	Lever ass'y, SST	

*Recommended spare parts

Key	Description	Part Number
298*	O-ring, nitrile	1E222606992
299	Rocker, A96061 (aluminum)	
300	Clip, SST	
301	Lever spring seat, SST	
302	Lever spring, K08500 (pl steel)	
303*	Groove pin, SST	16A6380X012
304	Switch lever, polycarbonate/SST	
305	Switch lever cover plate, aluminum/chromate	
306*	Closing plate gasket, chloroprene	18A2898X012
307	Closing plate, SST	
308	Machine screw, pan hd, 18-8 SST (2 req'd)	
309	Tubing ass'y, SST	
310	Lithium grease (not furnished with controller)	
311	Anti-seize sealant (not furnished with controller)	

Controller Mounting Parts

Note

Contact your Emerson Process Management sales office for any additional parts required for controller mounting.

Pipestand Mounting (figure 2-2)

66	Cap screw, hex hd, pl steel (3 req'd)
67	Lock washer, pl steel (7 req'd)
68	Bracket, pl steel
69	Clamp, pl steel (2 req'd)

Pipestand Mounting with Regulator (figure 2-2)

66	Cap screw, hex hd, pl steel (3 req'd)	
67	Lock washer, pl steel (7 req'd)	
68	Bracket, pl steel	
69	Clamp, pl steel (2 req'd)	
362	Cap screw, hex hd, pl steel (2 req'd)	
363	Lock washer, 18-8 SST (2 req'd)	
364	Hex nut, A563 (pl steel) (2 req'd)	
365	Tubing fittings (2 req'd)	See fittings subsection

Key	Description
-----	-------------

Panel Mounting (figure 2-3)

66	Cap screw, hex hd, pl steel (3 req'd)
67	Lock washer, pl steel (3 req'd)
68	Bracket, A569 (pl steel)
70	Machine Screw, rd hd, pl steel (4 req'd)

Wall Mounting (figure 2-4)

66	Cap screw, pl steel (3 req'd)
67	Lock washer, pl steel (3 req'd)
68	Bracket, pl steel

Controller Mounting Parts for Actuator With Casing- Mounted Controller

Spacer spool, steel (3 req'd)
Cap screw, hex hd, pl steel (3 req'd)
Lock washer, pl steel (5 req'd)
Mounting bracket, A569 (pl steel)
Cap screw, hex hd, pl steel (2 req'd)
Mounting bracket, G10100 (pl steel)
For 657/667 size 80 & 100
For all other types
Cap screw, hex hd, pl steel (2 req'd)
Hex nut, pl steel (2 req'd)
Washer, pl steel (2 req'd)
Washer, G10100 (pl steel) (2 req'd)

Controller Mounting Parts for Actuator With Yoke- Mounted Controller (figure 2-1)

Spacer spool, steel (3 req'd)
Cap screw, hex hd, pl steel (3 req'd)
Lock washer, pl steel (5 req'd)
Mounting bracket, steel
For 1061 w/switches or manual operator
For all other types
Spacer spool, steel (2 req'd)
Cap screw, hex hd, pl steel (2 req'd)

Regulator Mounting Parts

Description

Regulator Mounting Parts for Casing-Mounted Regulator

Cap screw, hex hd, pl steel
(2 req'd)
Lock washer, pl steel (2 req'd)
Cap screw, hex hd, pl steel (2 req'd)
Hex nut, pl steel (2 req'd)
Mounting bracket, G10100 (pl steel)
For 657/667 size 80 & 100
For all other types

Regulator Mounting Parts for Yoke-Mounted Regulator (Mounting Bracket Not Required)

Cap screw, hex hd, pl steel (2 req'd)
Lock washer, pl steel (2 req'd)

Regulator Mounting Parts for Yoke-Mounted Regulator (With Mounting Bracket)

Cap screw, hex hd, pl steel
(2 req'd)
Lock washer, pl steel (4 req'd)
Cap screw, hex hd, pl steel
(2 req'd)
Hex nut, pl steel (2 req'd)
Mounting bracket, G10100 (pl steel)
For 1061, size 30, all shaft sizes
For all other types

Fittings

Description

Note

The quantity shown make up the fitting for one end of the tubing or hose. Specify quantity of fittings required.

Fittings for 3/8-inch tubing, casing- or yoke-mounted controller with regulator

Connector, brass (2 req'd)

Elbow, brass (2 req'd)

Fittings for 3/8-inch tubing, pipestand-mounted controller with regulator

Elbow, brass (2 req'd)

Fittings for 3/8-inch tubing, all controllers without regulator

Connector, brass (1 req'd)

Elbow, brass (1 req'd)

Fittings for 1/2-inch synthetic rubber hose, all controllers w/ or w/o regulator

Connector, 316 SST

Elbow, 316 SST

Swivel, 316 SST (2 req'd)

Neither Emerson, Emerson Process Management, nor any of their affiliated entities assumes responsibility for the selection, use or maintenance of any product. Responsibility for proper selection, use, and maintenance of any product remains solely with the purchaser and end user.

Fisher is a mark owned by one of the companies in the Emerson Process Management business unit of Emerson Electric Co. Emerson Process Management, Emerson, and the Emerson logo are trademarks and service marks of Emerson Electric Co. All other marks are the property of their respective owners.

The contents of this publication are presented for informational purposes only, and while every effort has been made to ensure their accuracy, they are not to be construed as warranties or guarantees, express or implied, regarding the products or services described herein or their use or applicability. All sales are governed by our terms and conditions, which are available upon request. We reserve the right to modify or improve the designs or specifications of such products at any time without notice.

Emerson Process Management
Marshalltown, Iowa 50158 USA
Sorocaba, 18087 Brazil
Chatham, Kent ME4 4QZ UK
Dubai, United Arab Emirates
Singapore 128461 Singapore

www.Fisher.com