

# Baumann™ 24000F Wafer Control Valve

## Contents

Introduction .....	1
Scope of Manual .....	1
Safety Precautions .....	2
Maintenance .....	2
Installation .....	3
Air Piping .....	3
Disassembly .....	4
Lapping the Metal Seat .....	5
Replacing Packing .....	5
Actuator and Valve Body Reassembly .....	6
Parts Ordering .....	6
Dimensions and Weights .....	15

Figure 1. 24000F Control Valve

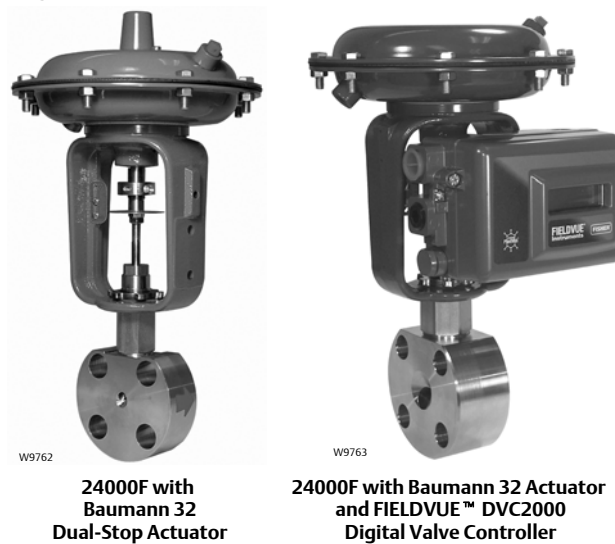

## Introduction

The Baumann 24000F Wafer Body Control Valve (figures 1) mates with ASME and EN line flange connections and is designed to control a wide range of process liquids, gases and vapors. This compact package provides the connection integrity of flanged body globe valves while being significantly lighter and easier to install.

## Scope of Manual

This instruction manual includes installation, maintenance, and parts information for the Baumann 24000F wafer body control valve.

Do not install, operate, or maintain Baumann 24000F control valves without being fully trained and qualified in valve, actuator, and accessory installation, operation, and maintenance. **To avoid personal injury or property damage, it is important to carefully read, understand, and follow all the contents of this manual, including all safety cautions and warnings.** If you have any questions about these instructions, contact your Emerson Process Management sales office before proceeding.



**⚠ WARNING**

Always wear protective gloves, clothing and eyewear when performing any installation operations to avoid personal injury.

Personal injury or property damage caused by sudden release of pressure or bursting of pressure retaining parts may result if service conditions exceed those for which the product was intended. To avoid injury or damage, provide a relief valve for over pressure protection as required by government or accepted industry codes and good engineering practices.

Check with your process or safety engineer for any additional measures that must be taken to protect against process media.

If installing into an existing application, also refer to the WARNING at the beginning of the Maintenance section in this instruction manual.

**CAUTION**

This valve is intended for a specific range of pressures, temperatures and other application specifications. Applying different pressures and temperatures to the valve could result in parts damage, malfunction of the control valve or loss of control of the process. Do not expose this product to service conditions or variables other than those for which the product was intended. If you are not sure what these conditions are you should contact your Emerson Process Management sales office for more complete specifications. Provide the product serial numbers (shown on the nameplate) and all other pertinent information.

**⚠ WARNING**

If you move or work on an actuator installed on a valve with loading pressure applied, keep your hands and tools away from the stem travel path to avoid personal injury. Be especially careful when removing the stem connector to release all loading on the actuator stem whether it be from air pressure on the diaphragm or compression in the actuator springs.

Likewise take similar care when adjusting or removing any optional travel stop. Refer to the relevant actuator Maintenance Instructions.

If hoisting the valve, take care to prevent people from being injured in case the hoist or rigging slips. Be sure to use adequate sized hoists and chains or slings to handle the valve.

**⚠ WARNING**

Personal injury could result from packing leakage. Valve packing is tightened before shipment; however, the packing might require some readjustment to meet specific service conditions.

## Maintenance

**⚠ WARNING**

Avoid personal injury and property damage from sudden release of process pressure or bursting of parts. Before performing any maintenance operations:

- Do not remove the actuator from the valve while the valve is still pressurized.
- Always wear protective gloves, clothing, and eyewear when performing any maintenance operations.
- Disconnect any operating lines providing air pressure, electric power, or a control signal to the actuator. Be sure the actuator cannot suddenly open or close the valve.
- Use bypass valves or completely shut off the process to isolate the valve from process pressure. Relieve process pressure on both sides of the valve. Drain the process media from both sides of the valve.
- Depending on the actuator construction, it will be necessary to manage the pneumatic actuator spring pre-compression. It is essential to refer to the relevant actuator instructions in this manual to perform safe removal of the actuator from the valve.
- Use lock-out procedures to be sure the above measures stay in effect while you work on the equipment.
- The valve packing box may contain process fluids that are pressurized, *even when the valve has been removed from the pipeline*. Process fluids may spray out under pressure when removing the packing hardware or packing rings, or when loosening the packing box pipe plug.
- Check with your process or safety engineer for any additional measures that must be taken to protect against process media.

#### Note

Whenever a gasket seal is disturbed by removing or shifting gasketed parts, install a new gasket during reassembly. This provides a good gasket seal because the used gasket may not seal properly.

#### **⚠ WARNING**

Avoid personal injury or property damage by thoroughly cleaning the line of all dirt, welding chips, scale, oil or grease, and other foreign material. Failure to do so could result in damage to the seating and sealing surfaces of the valve and result in damage to the valve and release of process materials.

## Installation

1. Before installing the valve in the pipeline, thoroughly clean the line of all dirt, welding chips, scale, oil or grease, and other foreign material.
2. Install the valve so the controlled fluid will flow through the valve body in the direction indicated by the arrow cast on the valve body.
3. A three-valve bypass must be used to permit removal of the control valve from the line without shutting down the system.
4. In case of a heat-insulated installation, insulate the valve body only, not the bonnet.

#### **⚠ WARNING**

To avoid personal injury or property damage, do not attempt to do any work on a valve while the system is in operation. The valve must be isolated 100% from the active system and the isolated line voided of pressure and/or hazardous fluids.

## Air Piping

1. For an air-to-extend actuator (air-to-close action), connect the actuating air pressure line to the 1/4 NPT opening in the upper diaphragm case. For an air-to-retract actuator (air-to-open action) connect the actuating air pressure line to the 1/4 NPT in the lower diaphragm case.

2. Use 6.4 mm (1/4 inch) O.D. tubing or equivalent for all air lines. If air line exceeds 8 m (25 ft) in length, 9.5 mm (3/8 inch) tubing is preferred. Air lines must not leak. Air pressure not to exceed 2.5 bar (35 psig).

## Disassembly

### **⚠ WARNING**

If there is evidence of process fluid under pressure leaking from the joint, retighten the valve body/joint nuts. Return to the **Warning at the beginning of the Maintenance section** to ensure proper steps have been taken to isolate the valve and relieve process pressure.

### **CAUTION**

- When assembling or disassembling the valve, do not turn the valve stem while the plug is touching the valve seat. This will damage the valve's seating surfaces.
- When adjusting the valve stem, do not grip the stem directly with pliers or a wrench. This will damage the surface of the stem, and cause damage to the packing in the valve. Instead, counter-tighten the two locknuts (key 27) on the stem (key 5). This will allow you to turn the stem by turning the locknuts (key 27) with a wrench.
- When placing the valve in a vise, do not clamp the rounded sides of the valve. This will distort the shape of the casting, and will ruin the valve.

## Actuator Removal

Access to the internal components of the valve body can be accomplished with the actuator removed. For actuator maintenance see the following instruction manual (Baumann Actuator Instructions, D103352X012).

### Air-to-Close Actuators

1. Disconnect the air supply to the actuator and remove the air tubing.
2. Loosen the drive nut (key 9) and then remove the plug and stem (keys 4 and 5) assembly by holding the actuator stem still while unthreading the plug and stem assembly counterclockwise.
3. Remove the stem locknuts (key 27), travel indicator (key 58), and yoke drive nut (key 9).
4. Remove the actuator from the valve.

### Air-to-Open Actuators

1. Using flexible tubing, apply sufficient air pressure to the actuator to lift the plug off the seat.
2. Loosen the drive nut (key 9) and then remove the plug and stem (keys 4 and 5) assembly by holding the actuator stem still while unthreading the plug and stem assembly counterclockwise.
3. Remove the stem locknuts (key 27), travel indicator (key 58), and yoke drive nut (key 9).
4. Remove the actuator from the valve.
5. Disconnect the air supply to the actuator and remove the air tubing.

## Valve Body Disassembly

1. After removing the actuator, unscrew the bonnet (key 8), and plug and stem (keys 4 and 5) from valve body (key 1). A new body gasket (key 49) should be installed each time the valve is disassembled.

2. Loosen the packing spring load by removing the packing follower (key 10).

Remove the plug and stem assembly by pulling it out through the bottom of the bonnet (key 8) while rotating the stem (key 5). This will help prevent damage to the packing components.

---

**Note**

Handle the parts carefully to avoid damaging the seating and guiding surfaces. Wipe the parts with a clean soft cloth and examine for signs of wear or damage.

---

3. To remove the seat ring (key 2), use a 5/8 inch socket wrench. Clean the seat ring thoroughly and examine for signs of wear or damage.
4. Low Flow Trims:
  - a. For Baumann 151 trim (figure 5) unscrew the seat subassembly. When reassembling, hand tighten the subassembly (key 51) and then rotate 1/8 of a turn with the 5/8 inch socket to lock in place.

---

**Note**

If changing to Baumann 151 trim, for correct flow characteristics, be sure the valve is reversed in the pipeline so that flow direction is flow-to-close.

---

- b. For Baumann 177 trim (figure 6) unscrew the retainer nut (key 24) using a 3/4 inch socket wrench. Remove the gland (key 23) and insert (key 25). Replace the insert (key 25), making sure that the tapered portion faces up. If replacement of the housing (key 26) is required, use a 5/8 inch socket wrench.

## Lapping the Valve Seat

If valve seat leakage becomes excessive, it may be necessary to lap the valve seat.

Lapping is the process of mating the valve plug to the seat ring, with an abrasive to produce a close fit. When valve seat leakage becomes excessive, lapping becomes necessary. The plug and seat ring seating surfaces should be free of large scratches or dents and the contact surface of the seats should be as narrow as possible.

1. Disassemble the valve body and remove the plug and stem assembly (keys 4 and 5) as directed in the previous Valve Body Disassembly section in this instruction manual.
2. Use a good quality lapping compound with a mixture that contains 280 to 600 grit. Apply at several spots around the plug seating surface. Replace the plug and stem carefully in the bonnet.
3. Install the bonnet (key 8) into the valve body, without gasket and hand tighten. The bonnet will serve as a guide during the lapping operation.
4. Lap the valve by applying a slight pressure on the stem and rotate the stem in short oscillating strokes approximately 8 to 10 times or until you see an even and complete lap line. The plug should be intermittently lifted and turned 90 degrees while lapping to keep the plug and seat ring concentric.
5. Clean the valve seat and plug (key 4) thoroughly when lapping is complete, removing all traces of lapping compound.
6. For the NPS 1 integral seat body, inspect internal seating surface for wear or damage and replace if necessary.

## Replacing Packing

Refer to figure 2 and the standard and optional packing constructions (figures 7, 8, and 9) to determine the packing that has been preinstalled in your valve.

1. Disassemble the valve as directed earlier. Remove the locknuts (key 27) and indicator disk (key 58), and turn the plug stem (key 5) out through the packing box. Remove the packing follower (key 10). Push out the old packing (key 14) by working from the underside of the bonnet (key 8).
2. **Standard Spring Loaded PTFE V-Ring Packing (figures 2 and 7):** Carefully insert each piece in exact order shown in figure 7. Turn the packing follower (key 10) until it shoulders on the bonnet (key 8). This will compress the packing spring (key 6) to enable constant stem sealing throughout packing life.
3. **Molded Graphite Ribbon Packing (figure 8):** Carefully insert each piece in exact order shown in figure 8. Hand tighten the packing follower (key 10). Use a wrench to increase tightness by turning the follower an additional 60 degrees.
4. **ENVIRO-SEAL™ Packing (figure 9):** Carefully insert each piece in exact order as shown in figure 9. Tighten the packing follower (key 10) until the Belleville springs are compressed. This will be signaled by a significant increase in resistance. Back off the follower 1/8 to 1/4 turn. A gap of approximately 1.5 mm (1/16 inch) between the packing follower and the bonnet will ensure the packing is seated properly.

## Actuator and Valve Body Reassembly

1. Insert a new valve body gasket (key 49) and install the bonnet assembly (key 8).
2. Place the actuator yoke over the stem (key 5). While tilting the actuator back, drop the yoke drive nut (key 9) over the stem (key 5). Run the locknuts (key 27), and the travel indicator (key 58), down as far as possible and counter tighten the locknuts (key 27) to lock.
3. Carefully position the actuator over the stem (key 5), lift the plug stem (key 5) and turn the plug stem (key 5) into the actuator stem as far as it will go before adjusting the bench range.

See the following instruction manual (Baumann Actuator Instructions, D103352X012) for reassembly and bench range adjustment.

### CAUTION

**When assembling or disassembling the valve, do not turn the valve stem while the plug is in contact with the valve seat. This can damage the seating surface very quickly.**

### ⚠ WARNING

**To avoid personal injury or equipment damage due to possible sudden shifting or falling of the valve assembly, do not lift the valve assembly by the handwheel.**

## Parts Ordering

When corresponding with your Emerson Process Management sales office about this equipment, always mention the valve serial number. When ordering replacement parts, also specify the key number, part name, and desired material using the following parts tables.

### ⚠ WARNING

**Use only genuine Fisher® replacement parts. Components that are not supplied by Emerson Process Management should not, under any circumstances, be used in any Fisher valve, because they may void your warranty, might adversely affect the performance of the valve, and could cause personal injury and property damage.**

Figure 2. Baumann 24000F Valve Body with Standard Bonnet and NPS 1 Integral Seat

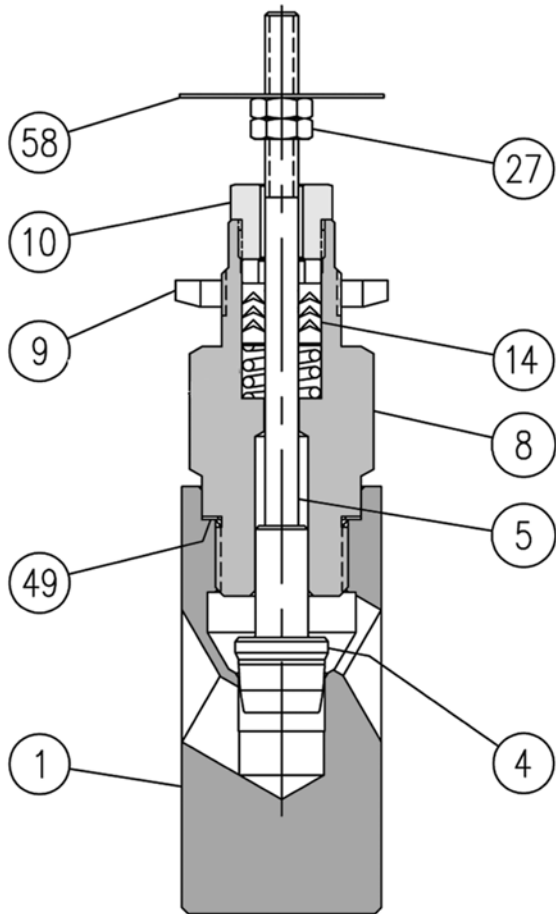

E1278

Figure 3. Baumann 24000F Valve Body with Extension Bonnet and Screwed-In Seat Ring

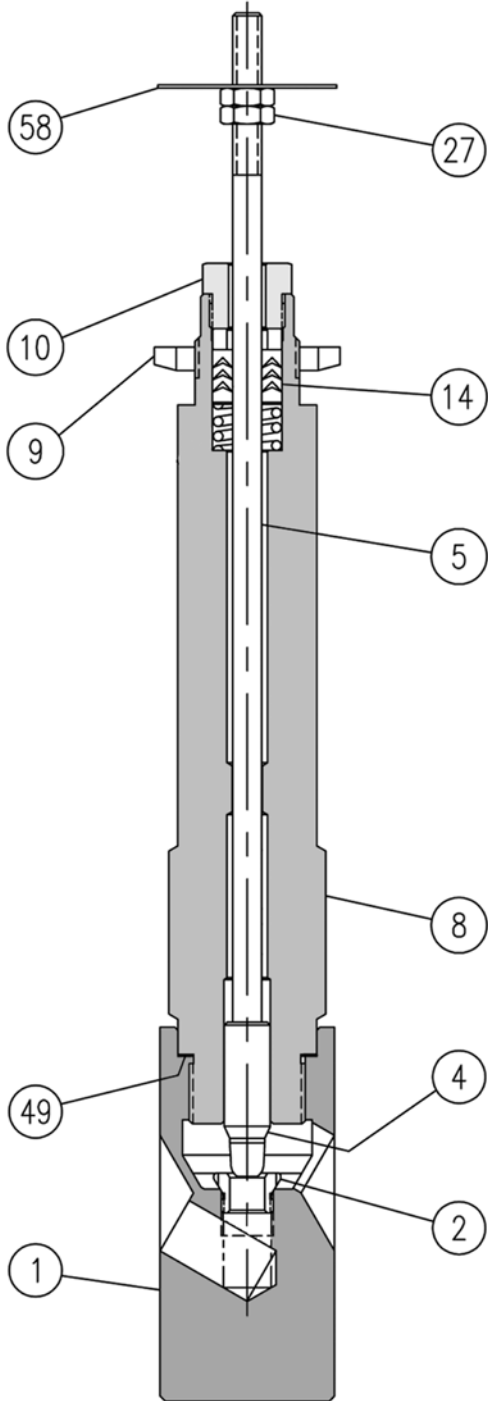

E1279



Table 1. Baumann 24000F Common Parts<sup>(1)</sup>

KEY NO.	QTY	DESCRIPTION	REMARKS	VALVE SIZE		
				DN 15 (NPS 1/2)	DN 20 (NPS 3/4)	DN 25 (NPS 1)
				Part Number	Part Number	Part Number
1	1	Valve Body	Screwed Seat	24511	24518	24524
			Integral Seat	N/A	N/A	24521
4*	1	Plug (Metal Seat)	See table 2			
		Plug (Soft Seat)	See table 3			
8	1	Bonnet	Standard	24516-3	24516-3	24522-3
			Extension	24856	24856	24529
9	1	Yoke Drive Nut	011757-003-153	011757-003-153	011757-003-153	
10	1	Packing Follower	24490-1	24490-1	24490-1	
14	1	Packing Kit (standard)	24494T001			
		Packing Kit (optional)	See page 13			
27	2	Lock Nut	971514-002-250	971514-002-250	971514-002-250	
49*	1	Body Gasket	24513	24513	24156	
			24513-1	24513-1	24156-1	
58	1	Travel Indicator	24299	24299	24299	

1. Contact your Emerson Process Management sales office for part number, price, and delivery on optional valve and trim materials (N10276, N08020, and N04400)

**For Extension Bonnet Construction**

Substitute                -104 for -101  
                                  -105 for -102

Table 2. Plug and Seat Ring for Metal Seat

KEY NO.	DESCRIPTION	PLUG TYPE	PLUG NO.	ORIFICE DIAMETER mm (Inch)	C <sub>v</sub>	K <sub>v</sub>	VALVE SIZE		
							DN 15 (NPS 1/2)	DN 20 (NPS 3/4)	DN 25 (NPS 1)
4*	Plug & Stem Assy	Metal Seat, Micro Trim (Linear)	102	6.3 (0.25)	0.02 <sup>(1)</sup>	0.017 <sup>(1)</sup>	GE46385X012		
					0.05 <sup>(1)</sup>	0.043 <sup>(1)</sup>	GE46386X012		
					0.1 <sup>(1)</sup>	0.086	GE46387X012		
					0.2 <sup>(1)</sup>	0.17 <sup>(1)</sup>	GE46388X052		
		Metal Seat (Equal %)	548 (416 SST)	6.3 (0.25)	0.2 <sup>(1)</sup>	0.17 <sup>(1)</sup>	GE46393X012		
					0.5 <sup>(1)</sup>	0.43 <sup>(1)</sup>	GE46394X012		
					1.0	0.86	GE46392X012		
				9.5 (0.375)	1.5	1.29	24634-6-101-548		
					2.0	1.72	24171-12-101-548		---
					2.5	2.15	---	---	24171-12-101-548
				20.6 (0.8125)	4	3.44	---	---	24185-6-101-548
					6.5	5.59	---	---	24061-5-101-548
		Metal Seat (Equal %)	588	6.3 (0.25)	0.2 <sup>(1)</sup>	0.17 <sup>(1)</sup>	GE46390X012		
					0.5 <sup>(1)</sup>	0.43 <sup>(1)</sup>	GE46391X012		
					1.0	0.86	GE46389X012		
				9.5 (0.375)	1.5	1.29	24634-101-588		
					2.0	1.72	24171-101-588		---
					2.5	2.15	---	---	24171-101-588
				20.6 (0.8125)	4	3.44	---	---	24185-101-588
					6.5	5.59	---	---	24061-101-588
		Metal Seat (Linear)	648 (416 SST)	6.3 (0.25)	0.5	0.43	GE46398X012		
					1.0	0.86	GE46397X012		
				9.5 (0.375)	1.5	1.29	24669-1-101-648		
					2.0	1.72	24671-2-101-648		---
					2.5	2.15	---	---	24671-2-101-648
				20.6 (0.8125)	4	3.44	---	---	24757-5-101-648
					6.5	5.59	---	---	24717-3-101-648
				Metal Seat (Linear)	688	6.3 (0.25)	0.5	0.43	GE46396X012
1.0	0.86	GE46395X012							
9.5 (0.375)	1.5	1.29	24669-101-688						
	2.0	1.72	24671-101-688			---			
	2.5	2.15	---			---	24671-101-688		
20.6 (0.8125)	4	3.44	---			---	24757-101-688		
	6.5	5.59	---			---	24717-101-688		
2*	Seat Ring	9.5 mm (0.375 in) Orifice Diameter, 316 SST				24167			
		9.5 mm (0.375 in) Orifice Diameter, 416 SST				24167-3			

1. Matching seat ring (key 2) must be furnished with replacement plug orders.

Table 3. Plug and Seat Ring for Soft Seat

KEY NO.	DESCRIPTION	PLUG TYPE	PLUG NO.	ORIFICE DIAMETER mm (Inch)	C <sub>v</sub>	K <sub>v</sub>	VALVE SIZE		
							DN 15 (NPS 1/2)	DN 20 (NPS 3/4)	DN 25 (NPS 1)
4*	Plug/Stem	PTFE Seat (Equal %)	577	9.5 (0.375)	1.0	0.86	24893-101-577		
					1.5	1.29	24796-101-577		
					2.0	1.72	24609-101-577		---
				2.5	2.15	---	---	24609-101-577	
				20.6 (0.8125)	4	3.4	---	---	24010-2-101-577
					6.5	5.6	---	---	24010-101-577
		PTFE Seat (Linear)	677		9.5 (0.375)	0.1	0.086	24660-101-677	
				0.2		0.172	24625-101-677		
				0.5		0.43	24617-101-677		
				1.0		0.86	24631-101-677		
				2.0		1.72	24656-101-677		---
				2.5		2.15	---	---	24656-101-677
2*	Seat Ring	6.3 mm (0.25 in) Orifice Diameter				24161			
		9.5 mm (0.375 in) Orifice Diameter				24167			

Figure 4. Baumann 24000F Trims

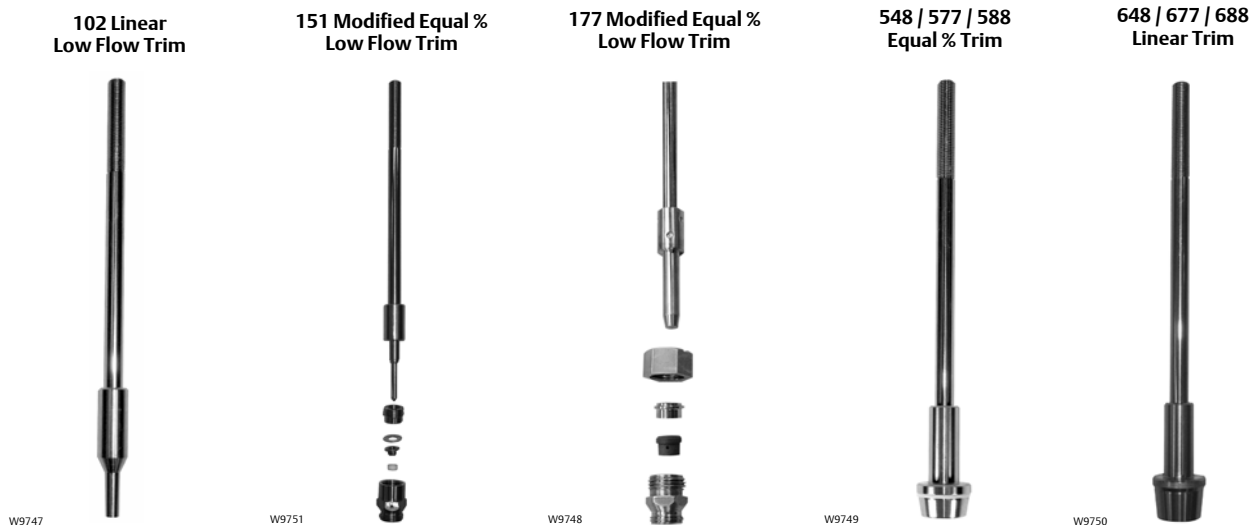

\*Recommended spare parts

Figure 5. Optional 151 Low Flow Trim Assembly

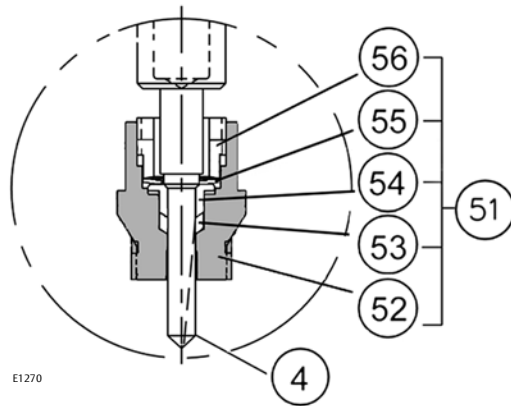

E1270

Figure 6. Optional 177 Low Flow Trim Assembly

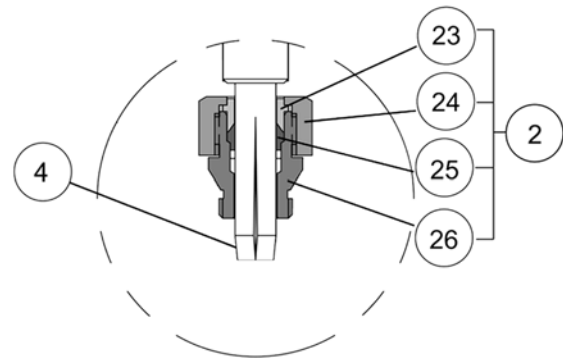

E1271

Table 4. Plug and Seat for Baumann 151 Trim

KEY NO.	DESCRIPTION	PLUG TYPE	PLUG SERIES	ORIFICE DIAMETER mm (Inch)	C <sub>v</sub>	K <sub>v</sub>	VALVE SIZE		
							DN 15 (NPS 1/2)	DN 20 (NPS 3/4)	DN 25 (NPS 1)
4*	Plug & Stem Assy	Modified Equal % Low Flow	151	3.96 (0.156)	0.00013	0.0001	24151-2-101-151		
					0.00025	0.0002	24151-3-101-151		
					0.0005	0.0004	24151-4-101-151		
					0.001	0.0009	24151-5-101-151		
					0.002	0.0017	24151-6-101-151		
					0.004	0.003	24151-7-101-151		
					0.008	0.007	24151-8-101-151		
					0.015	0.013	24151-9-101-151		
					0.03	0.026	24151-10-101-151		
					0.06	0.052	24151-11-101-151		
					0.1	0.86	24151-12-101-151		
					0.2	0.17	24151-24-101-151		
					0.45	0.39	24151-25-101-151		
51*	Seat Sub-Assembly						24151-20		

Table 5. Plug and Seat for Baumann 177 Trim

KEY NO.	DESCRIPTION	PLUG TYPE	PLUG SERIES	ORIFICE DIAMETER mm (Inch)	C <sub>v</sub>	K <sub>v</sub>	VALVE SIZE		
							DN 15 (NPS 1/2)	DN 20 (NPS 3/4)	DN 25 (NPS 1)
2*	Seat Sub-Assembly (See table 6)						24241		
4*	Plug & Stem Assy	Low Flow	177	7.9 (0.3125)	0.0005	0.0004	24598-101-177		
					0.001	0.0009	24597-101-177		
					0.002	0.0017	24594-101-177		
					0.005	0.004	24595-101-177		
					0.01	0.009	24596-101-177		
					0.02	0.017	24621-10-101-177		
					0.05	0.04	24658-10-101-177		

Table 6. Baumann 177 Low Flow Trim

Key No.	Description		
4*	Plug (see table 5)		
2a*	23	Gland	Seat Ring Subassembly, P/N 24241
	24	Retainer Nut	
	25	Insert	
	26	Housing	

Figure 7. Spring-Loaded PTFE V-Ring Packing Kit P/N 24494T001

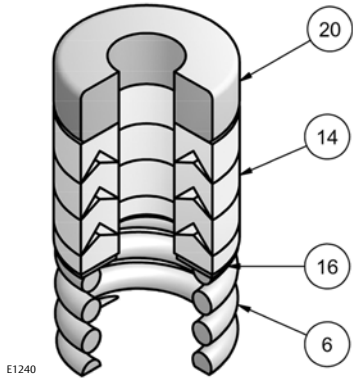

E1240

Figure 9. ENVIRO-SEAL Packing Kit P/N 24490T001

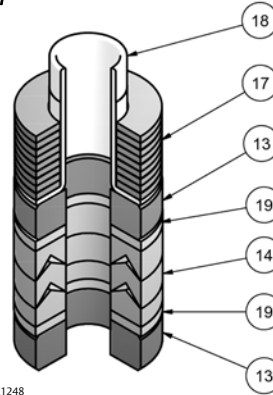

E1248

Table 7. Spring-Loaded PTFE V-Ring Packing Kit P/N 24494T001

Key No.	Description	Material
6*	Spring	ASTM A313 S30200
14	Packing Set	PTFE / carbon-filled PTFE
16	Washer	ASTM A240 S31600
20	Spacer	J-2000 (filled PTFE)

Table 9. ENVIRO-SEAL Packing Kit P/N 24490T001

Key No.	Description	Material
13	Bushing, qty 2	Carbon Graphite
14	Packing Set	PTFE / carbon-filled PTFE
17	Belleville Spring	ASTM B637 N07718
18	Bushing	PEEK
19	Washer, qty 2	Modified PTFE

Figure 8. Molded Graphite (Flexible Graphite) Packing Kit P/N 24492T001

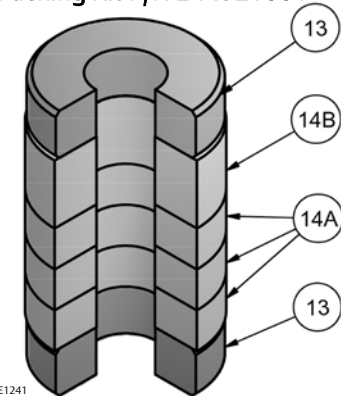

E1241

Table 8. Molded Graphite (Flexible Graphite) Packing Kit P/N 24492T001

Key No.	Description	Material
13	Bushing, qty 2	Carbon - Graphite
14A	Packing Ring, qty 3	Graphite
14B	Packing Ring	Graphite

## Special ENVIRO-SEAL Packing Note

The ENVIRO-SEAL PTFE packing system is suitable for 100 ppm environmental applications on services up to 51.7 barg (750 psig) and process temperatures ranging from -46 to 232°C (-50 to 450°F).

For non-environmental applications, this packing system offers excellent performance at the same temperature range up to the maximum valve working pressure.

Temperature limits apply to packing arrangements only. Complete valve assembly temperature limits may differ. Refer to appropriate pressure/ temperature ratings.

Reference Fisher Packing Selection Guidelines for Sliding-Stem Valves, bulletin 59.1:062, D101986X012.

Figure 10. Dimensional Drawings

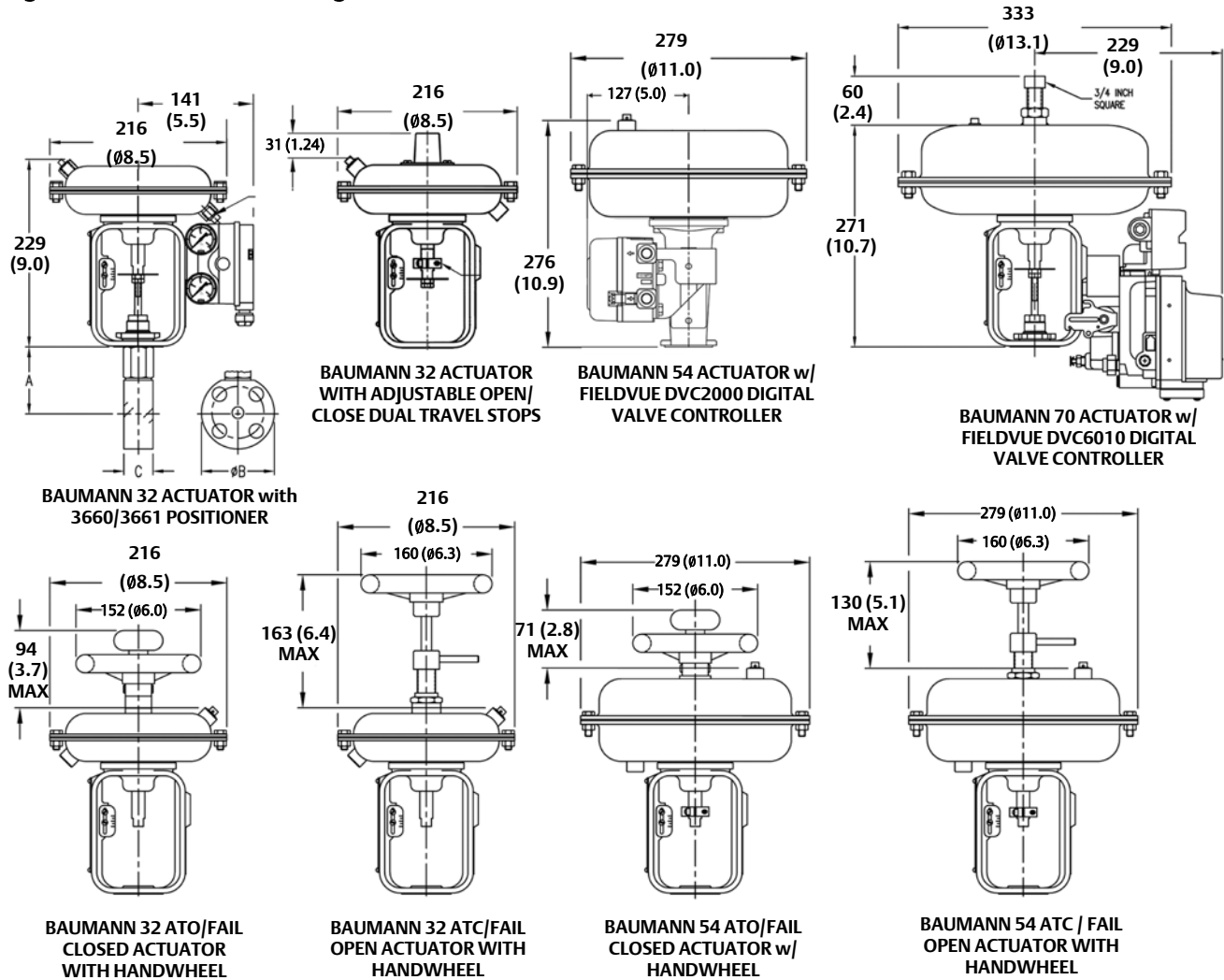

mm  
(Inch)

E1280

NOTE: ACTUATOR REMOVAL REQUIRES 115 mm (4.5 INCHES) VERTICAL CLEARANCE.

Table 10. Baumann Valve Dimensions

VALVE SIZE		A -- BONNET				B -- DIAMETER		C	
DN	NPS	Standard		Extension		mm	Inch	mm	Inch
		mm	Inch	mm	Inch			mm	Inch
15	1/2	81.3	3.2	218.4	8.6	88.9	3.5	38.1	1.5
20	3/4	81.3	3.2	218.4	8.6	107.95	4.25	38.1	1.5
25	1	78.7	3.1	215.9	8.5	114.3	4.5	50.8	2.0

Table 11. Baumann Valve Assembly Weights

VALVE SIZE		WEIGHTS	
DN	NPS	kg	lb
15	1/2	1.7	3.8
20	3/4	2.4	5.3
25	1	3.3	7.3

Table 12. Baumann Actuator Weights

ACTUATOR	WEIGHTS	
	kg	lbs
32	4.5	10
54	11.3	25
70	15.4	34
MV1020 <sup>(1)</sup>	10	22
VA1020 <sup>(1)</sup>	14	30

1. Electric actuators, reference electric actuator bulletins for more details (52.1:ECV, D103347X012 and 52.1:NVACT, D103326X012)

**Neither Emerson, Emerson Process Management, nor any of their affiliated entities assumes responsibility for the selection, use or maintenance of any product. Responsibility for proper selection, use, and maintenance of any product remains solely with the purchaser and end user.**

Baumann, Fisher, FIELDVUE, and ENVIRO-SEAL are marks owned by one of the companies in the Emerson Process Management business unit of Emerson Electric Co. Emerson Process Management, Emerson, and the Emerson logo are trademarks and service marks of Emerson Electric Co. All other marks are the property of their respective owners.

The contents of this publication are presented for informational purposes only, and while every effort has been made to ensure their accuracy, they are not to be construed as warranties or guarantees, express or implied, regarding the products or services described herein or their use or applicability. All sales are governed by our terms and conditions, which are available upon request. We reserve the right to modify or improve the designs or specifications of such products at any time without notice.

**Emerson Process Management**

Marshalltown, Iowa 50158 USA

Sorocaba, 18087 Brazil

Chatham, Kent ME4 4QZ UK

Dubai, United Arab Emirates

Singapore 128461 Singapore

[www.Fisher.com](http://www.Fisher.com)

