

# Baumann<sup>™</sup> 84000 Sanitary Diaphragm Angle and Inline Control Valve



## Contents

Introduction .....	1
Scope of Manual .....	1
Safety Precautions .....	2
Maintenance .....	3
Flow Direction .....	3
Installation .....	3
Air Piping .....	4
Valve Body Removal .....	4
Actuator Removal .....	4
Bonnet Disassembly .....	4
Bonnet Reassembly .....	4
Valve Calibration .....	5
Parts Ordering .....	6
Dimensions and Weights .....	11

## Introduction

The Baumann 84000 sanitary control valve (figures 1, 2, and 3) is designed to satisfy the stringent demands of the pharmaceutical and biotechnology industries. These valves are in compliance with 3-A Sanitary Standards, Inc. requirements.

## Scope of Manual

This instruction manual includes installation, maintenance, and parts information for the Baumann 84000 sanitary control valve.

Do not install, operate, or maintain Baumann 84000 control valves without being fully trained and qualified in valve, actuator, and accessory installation, operation, and maintenance. To avoid personal injury or property damage, it is important to carefully read, understand, and follow all the contents of this manual, including all safety cautions and warnings. If you have any questions about these instructions, contact your Emerson Process Management sales office before proceeding.



W9838

Figure 1. 84000 Inline Sanitary Valve with Baumann 32 Actuator



W9839

Figure 2. 84000 Angle Sanitary Valve with Baumann 32 Actuator and FIELDVUE™ DVC2000 Digital Valve Controller



W9840

Figure 3. 84000 Angle Sanitary Valve with Baumann 54 Actuator and FIELDVUE™ DVC6000 Digital Valve Controller



 **WARNING**

Always wear protective gloves, clothing and eyewear when performing any installation operations to avoid personal injury.

Personal injury or property damage caused by sudden release of pressure or bursting of pressure retaining parts may result if service conditions exceed those for which the product was intended. To avoid injury or damage, provide a relief valve for over pressure protection as required by government or accepted industry codes and good engineering practices.

Check with your process or safety engineer for any additional measures that must be taken to protect against process media.

If installing into an existing application, also refer to the **WARNING** at the beginning of the Maintenance section in this instruction manual.

**CAUTION**

This valve is intended for a specific range of pressures, temperatures and other application specifications. Applying different pressures and temperatures to the valve could result in parts damage, malfunction of the control valve or loss of control of the process. Do not expose this product to service conditions or variables other than those for which the product was intended. If you are not sure what

these conditions are you should contact your Emerson Process Management sales office for more complete specifications. Provide the product serial numbers (shown on the nameplate) and all other pertinent information.

 **WARNING**

If you move or work on an actuator installed on a valve with loading pressure applied, keep your hands and tools away from the stem travel path to avoid personal injury. Be especially careful when removing the stem connector to release all loading on the actuator stem whether it be from air pressure on the diaphragm or compression in the actuator springs.

Likewise take similar care when adjusting or removing any optional travel stop. Refer to the relevant actuator Maintenance Instructions.

If hoisting the valve, take care to prevent people from being injured in case the hoist or rigging slips. Be sure to use adequate sized hoists and chains or slings to handle the valve.

 **WARNING**

Personal injury could result from packing leakage. Valve packing is tightened before shipment; however, the packing might require some readjustment to meet specific service conditions.

## Maintenance

### WARNING

Avoid personal injury and property damage from sudden release of process pressure or bursting of parts. Before performing any maintenance operations:

- Do not remove the actuator from the valve while the valve is still pressurized.
- Always wear protective gloves, clothing, and eyewear when performing any maintenance operations.
- Disconnect any operating lines providing air pressure, electric power, or a control signal to the actuator. Be sure the actuator cannot suddenly open or close the valve.
- Use bypass valves or completely shut off the process to isolate the valve from process pressure. Relieve process pressure on both sides of the valve. Drain the process media from both sides of the valve.
- Depending on the actuator construction, it will be necessary to manage the pneumatic actuator spring pre-compression. It is essential to refer to the relevant actuator instructions in this manual to perform safe removal of the actuator from the valve.
- Use lock-out procedures to be sure the above measures stay in effect while you work on the equipment.
- The valve packing box may contain process fluids that are pressurized, *even when the valve has been removed from the pipeline.* Process fluids may spray out under pressure when removing the packing hardware or packing rings, or when loosening the packing box pipe plug.
- Check with your process or safety engineer for any additional measures

that must be taken to protect against process media.

### Note

Whenever a gasket seal is disturbed by removing or shifting gasketed parts, install a new gasket during reassembly. This provides a good gasket seal because the used gasket may not seal properly.

## Flow Direction

The preferred flow direction for self-draining is shown in figures 8 and 9.

## Installation

1. Before installing the valve in the pipeline, thoroughly clean the line of all dirt, welding chips, scale, oil or grease, and other foreign material. A micron size filter is recommended upstream of the valve.
2. Install valve so that the controlled fluid will flow through the valve body in the direction selected in figures 8 and 9. The leak detection port should be located at the lowest point in the installed position.
3. A three-valve bypass must be used to permit removal of the control valve from the line without shutting down the system.
4. To detect if leakage or breakage of the diaphragm has occurred, a pressure gauge may be installed in the 1/8 NPT port (key 14) in the bonnet, see figures 4, 5, and 6.

### WARNING

To avoid personal injury or property damage, do not attempt to do any work on a valve while the system is in operation, the valve must be isolated 100% from the active system and the isolated line voided of pressure and/or hazardous fluids.

# 84000 Valve

## Air Piping

1. For an air-to-extend actuator (air-to-close action), connect the actuating air pressure line to the 1/4 NPT opening in the upper diaphragm case. For an air-to-retract actuator (air-to-open action) connect the actuating air pressure line to the 1/4 NPT in the lower diaphragm case.
2. Use 6.4 mm (1/4 inch) O.D. tubing or equivalent for all air lines. If the air line exceeds 8 m (25 ft) in length, 9.5 mm (3/8 inch) tubing is preferred. Air lines must not leak. Air pressure should not exceed 2.5 bar (35 psig).

## Valve Body Removal

Reference figures 4, 5, and 6.  
(Not Required For Actuator Reversal)

For field replacement of the diaphragm (key 8), follow steps 1 through 4 below.

### Note

**Do not squeeze the valve body in a vise.**

1. For fail-closed action (air-to-open), stroke the actuator up to take pressure off from the diaphragm pushing against seat. For fail-open action (air-to-close), there is no need to stroke actuator.
2. Remove the bonnet screws (key 18) for NPS 1 valves or the clamp (key 11) for NPS 1-1/2 or 2 valves.
3. Lift the bonnet assembly (key 2) with the actuator from the valve body (key 1).
4. Once disassembled; for fail-closed action ONLY, release pressure from the actuator to be able to unscrew the diaphragm, for fail-open action you must pressurize the actuator to unscrew the diaphragm. This is the only action required for inspection or cleaning.
5. Stroke the actuator down to exert some pressure and remove the diaphragm (key 8) by unscrewing the diaphragm (key 8) from the compressor (key 5). Remove the bonnet O-ring (key 15) (NPS 1-1/2 and 2 valves only). Wipe the diaphragm (key 8) with a clean soft cloth and examine for wear.
6. Inspect the valve body sealing surfaces. If valve leakage becomes excessive, replacement of the diaphragm (key 8) may be necessary.

## Actuator Removal

To remove the actuator, unscrew the drive nut (key 9) and loosen the jam nuts (key 27). Unscrew the piston stem (key 3) from the actuator stem.

### CAUTION

**Avoid personal injury or property damage from sudden release of pressure or bursting of parts. Remove the actuator before attempting to disassemble the valve.**

## Bonnet Disassembly

### Actuator Removed

Remove the diaphragm (key 8) and the bonnet O-ring (key 15) (NPS 1-1/2 and 2 valves only) per instructions under the previous Valve Body Removal section. Proceed as follows:

1. Turn over the bonnet assembly (key 2).
2. Pry out the retaining ring (key 7) using a small flat screwdriver.
3. Remove the wave springs (key 6), compressor (key 5) and drive mechanism (key 4).
4. Push out the piston-stem assembly (key 3). Clean and replace as required.

### Note

**For NPS 1-1/2 & 2 valves, measure the gap between the free ends of the clamp (key 11) and return to this position upon reassembly to minimize change in zero calibration.**

## Bonnet Reassembly

### Actuator Removed

For correct orientation of the sub-assemblies to the bonnet refer to figure 7, exploded view.

1. Insert the piston stem assembly (key 3) into the bonnet (key 2).
2. Orient the drive mechanism as shown in figure 7.
3. Verify that the machined surfaces at the end of the rectangular plates are in full contact with the machined recess inside the bonnet (key 2).

4. **IMPORTANT:** Verify that the recessed roller bearings in the drive mechanism (key 4) rest against the flats of the piston stem assembly (key 3).
5. Install the compressor (key 5) per figures 4, 5, and 6 with the flat side resting against the extended roller bearings.
6. Drop the wave springs (key 6) into place, prongs down; the NPS 1 valve requires two wave springs. The NPS 1-1/2 and 2 valves require three wave springs. Oppose the spring opening 180 degrees when installing the wave springs.
7. Retain all parts by installing the retaining ring (key 7) into the bonnet groove.
8. The gap in the retaining ring (key 7) should align with the crest of the wave spring (key 6).
9. Push down on the bonnet assembly to drive the piston stem assembly (key 3) firmly into the drive mechanism (key 4) to provide some tension.
10. Insert the O-ring (key 15) (NPS 1-1/2 and 2 valves only), so that it rests on the retaining ring (key 7).
11. Lubricate the screw thread and the cone of the diaphragm (key 8) with sterile food grade lubricant.
12. Screw the diaphragm (key 8) onto the compressor (key 5) snugly. **DO NOT OVERTIGHTEN.**
13. Place the complete bonnet assembly onto the valve body (key 1).
  - a. The diaphragm (key 8) rim must fit into the body groove for proper centering.
  - b. The NPS 1 bolted flange configuration should be tightened for metal-to-metal contact between the flange and the valve body. Be sure to use 45 lbf•ft when tightening the valve body bolts on the NPS 1 valve.
  - c. For NPS 1-1/2 and 2 valves, apply the clamp (key 11) and tighten the nut gradually, checking for an even amount of PTFE over the valve body, between the bonnet and clamp, for proper centering.
  - d. The gap between the clamp ends should be approximately 1/2 inch or less for proper diaphragm compression. **DO NOT OVERTIGHTEN THE CLAMP.**
  - e. Examine through port B to ensure the diaphragm is centered on the seating area.

## Valve Calibration

After the valve is assembled per the previous instructions, install the properly configured actuator (reference the Baumann Pneumatic Actuators instruction manual, D103352X012), making sure to engage the piston stem (key 3) as much as possible into the actuator stem. Tighten the drive nut (key 9). (Refer to figures 8 and 9 for the preferred flow direction.)

### **Calibration of Fail-Close (Air-to-Open) Actuator**

1. Apply 50 psi air or nitrogen to port B. Apply 3 psi air signal to the actuator.
  - a. Slowly turn the piston stem assembly (key 3) out of the actuator stem until flow stops.

#### Note

**When adjusting the valve stem, do not grip the stem directly with pliers or a wrench. This will damage the surface of the stem. Instead, counter-tighten the two locknuts on the stem together. This will allow you to turn the stem by turning the locknuts with a wrench.**

- b. Check the valve for leaks with 50 psi air under the diaphragm (port B). Leakage should be less than 1 cc/min. The valve should start to leak or low flow at a minimum pressure signal to the actuator. If it takes more than minimum pressure to open, then screw the piston stem assembly (key 3) further into the actuator stem. If the valve is not tight at 3 psi signal, screw the piston stem assembly (key 3) out of the actuator stem further. Next, calibrate Zero on the travel indicator scale with a minimum pressure signal to the actuator. Check for full travel at the maximum pressure signal. If the leak persists, increase the force on the clamp (key 11) to compress the diaphragm (key 8) by tightening the clamp nut. For NPS 1 valves, tighten the bolts (key 18) on the bonnet flange (key 11) using 45 lbf•ft.

## CAUTION

**The stem should travel below zero by approximately 1/16 to 1/8 inch after the signal is decreased below 3 psi. IF THE VALVE DOES NOT CLOSE PROPERLY, INCREASE THE CLAMP COMPRESSION AROUND THE**

## 84000 Valve

**DIAPHRAGM (key 8) by tightening 1/2 turn. DO NOT tighten to the point that the diaphragm wrinkles.**

### ***Calibration of Fail-Open (Air-to-Close) Actuator***

2. Apply 50 psi air pressure or nitrogen to port B. Apply 15 psi air signal to actuator.
  - a. Slowly turn the piston stem assembly (key 3) out of the actuator stem until flow stops.
  - b. Check the valve for leaks with 50 psi air under the diaphragm (port B). Leakage should be less than 1 cc/min. The valve should start to leak or low flow at a maximum pressure signal to the actuator. If it takes more than the maximum pressure to open, then screw the piston-stem (key 3) further into the actuator stem. If the valve is not tight at 15 psi signal, screw the piston-stem (key 3) out of the actuator stem further. Next, calibrate Zero on the travel indicator scale with maximum pressure signal to the actuator. Check for full travel at minimum pressure signal. If the leak persists, increase the force on the clamp (key 11) to compress the diaphragm (key 8) by tightening the clamp nut. For NPS 1 valves, tighten the bolts (key 18) on the bonnet flange (key 11) using 45 lbf•ft.

### **CAUTION**

**The stem should travel below zero by approximately 1/16 to 1/8 inch after the signal is increased above 15 psi. IF THE VALVE DOES NOT CLOSE PROPERLY, INCREASE THE CLAMP COMPRESSION AROUND THE DIAPHRAGM (key 8) by tightening 1/2 turn. DO NOT tighten to the point that the diaphragm wrinkles.**

### **Note**

**When using a Baumann 32 actuator with dual stops or a Baumann 54 actuator, the shaft collar (key 25) can also be set at intermediate positions to provide a minimum opening valve travel stop.**

## **Parts Ordering**

When corresponding with your Emerson Process Management sales office about this equipment, always mention the valve serial number. When ordering replacement parts, also specify the key number, part name, and desired material using the following parts tables.

### **WARNING**

**Use only genuine Fisher® replacement parts. Components that are not supplied by Emerson Process Management should not, under any circumstances, be used in any Fisher valve, because they may void your warranty, might adversely affect the performance of the valve, and could cause personal injury and property damage.**

### **Note**

**Neither Emerson, Emerson Process Management, nor any of their affiliated entities assumes responsibility for the selection, use, or maintenance of any product. Responsibility for the selection, use, and maintenance of any product remains with the purchaser and end user.**

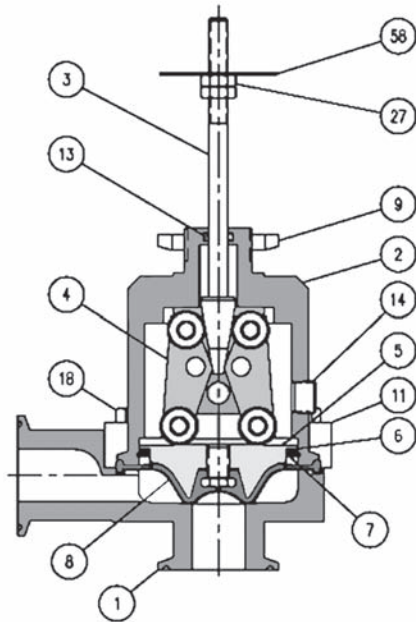

E1314

Figure 4. Baumann 84000 NPS 1 Angle Valve Body Sub-Assembly

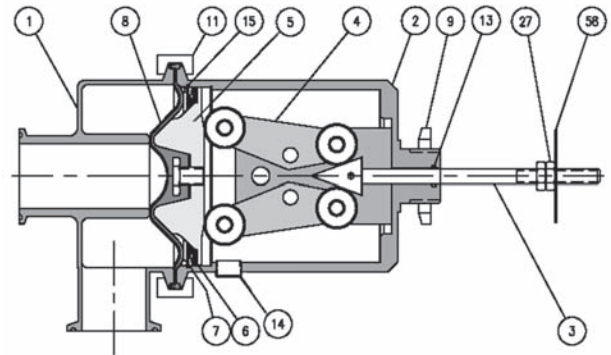

E1316

Figure 6. Baumann 84000 NPS 1-1/2 and 2 Angle Valve Body Sub-Assembly

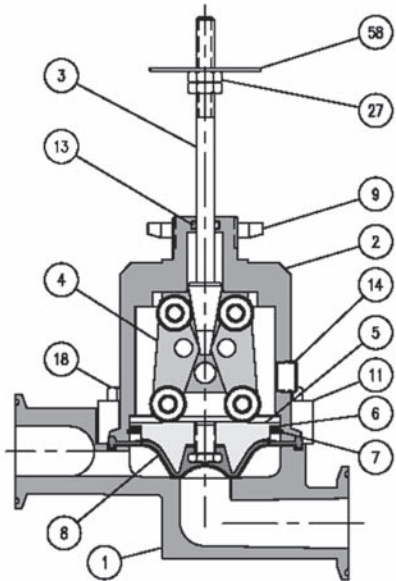

E1315

Figure 5. Baumann 84000 NPS 1 Inline Valve Body Sub-Assembly

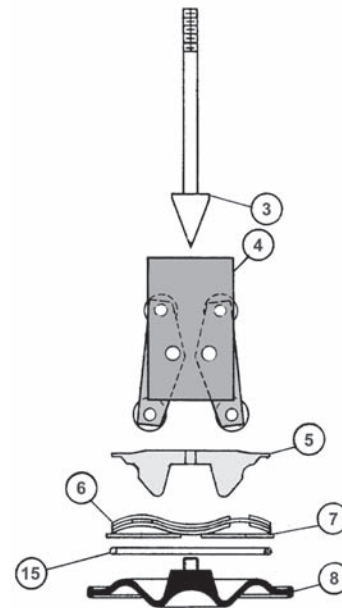

E1317

Figure 7. Baumann 84000 Linkage Mechanism

Table 1. Common Parts

KEY NO.	QTY	DESCRIPTION	VALVE SIZE			
			NPS 1 Angle	NPS 1 Inline	NPS 1-1/2 Angle	NPS 2 Angle
1	1	Valve Body, < 30 Ra Microinch	82128	82128-2	82124	82125
		Valve Body, < 20 Ra Microinch	82128-10	82128-2-1	82124-6	82125-4
2	1	Bonnet	82214	82215		
3*	1	Piston Stem Sub-Assembly Cv = 8	82610-001-999		---	---
		Piston Stem Sub-Assembly Cv = 4	82614-001-999		---	---
		Piston Stem Sub-Assembly Cv = 2	82621-001-999		---	---
		Piston Stem Sub-Assembly	---	---	82615-001-999	
4*	1	Drive Mechanism Sub-Assembly	82510-3		82515	
5*	1	Compressor	82413	82411	82412	
6*	2	Wave Spring	82710	---	---	
	3	Wave Spring	---	82712		
7*	1	Retaining Ring	82711	82713		
8*	1	Diaphragm, Closure Member	82310-6	82311-6	82312-6	
9	1	Drive Nut, Actuator Yoke	011757-003-153		011757-003-153	
11	1	Bonnet Flange	82213	---		
		Clamp	---	82814		
13*	1	O-Ring, Stem	24080	24080		
14	1	Tell Tale Port	82212	82212		
15*	1	O-Ring, Bonnet	---	82714		
18	4	Hex Head Cap Screw	82813	---		
27	2	Jam Nut	971514-002-250		971514-002-250	
58	1	Travel Indicator	Baumann 32 Actuator	24299	---	
			Baumann 54 Actuator	24299	24299	



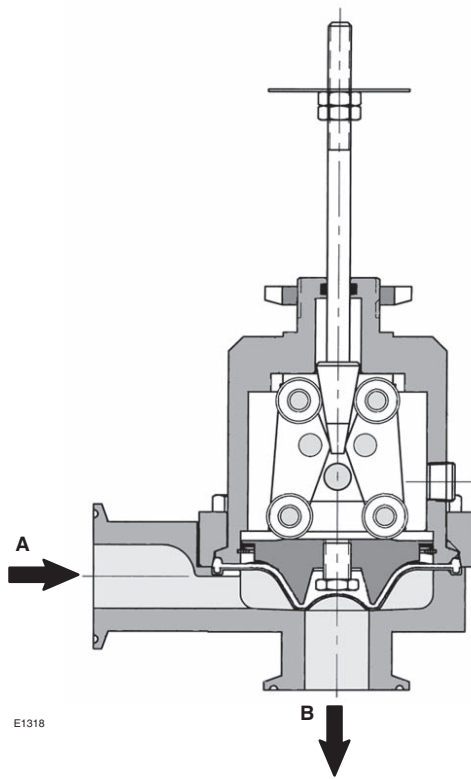

E1318

**NPS 1 ANGLE VALVE BODY POSITIONED FOR FORWARD FLOW SELF DRAINING FROM PORT A TO B**

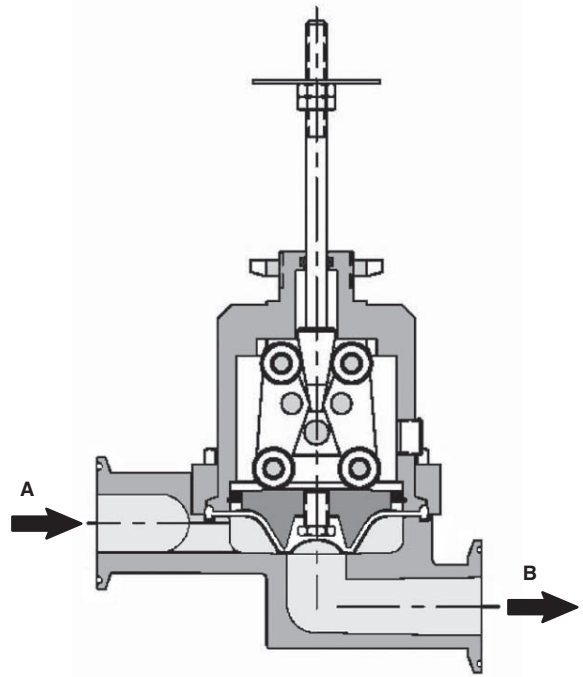

E1319

**NPS 1 INLINE VALVE BODY POSITIONED FOR FORWARD FLOW SELF DRAINING FROM PORT A TO B**

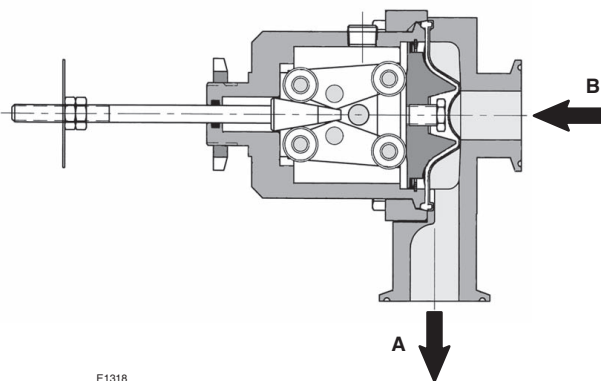

E1318

**NPS 1 ANGLE VALVE BODY POSITIONED FOR FORWARD FLOW SELF DRAINING FROM PORT B TO A (BONNET ROTATED 90° TO SHOW TELL-TALE PORT)**

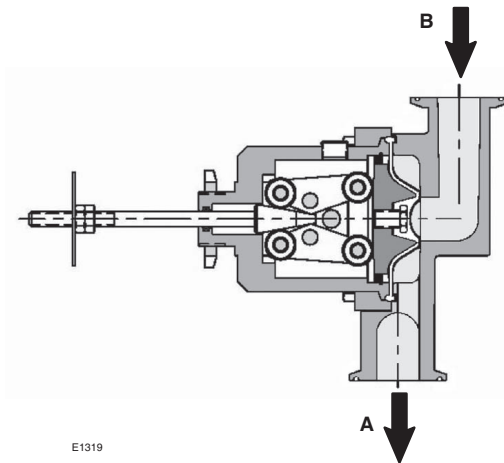

E1319

**NPS 1 INLINE VALVE BODY POSITIONED FOR FORWARD FLOW SELF DRAINING FROM PORT B TO A (BONNET ROTATED 90° TO SHOW TELL-TALE PORT)**

Figure 8. Preferred Flow Directions for Self-Draining

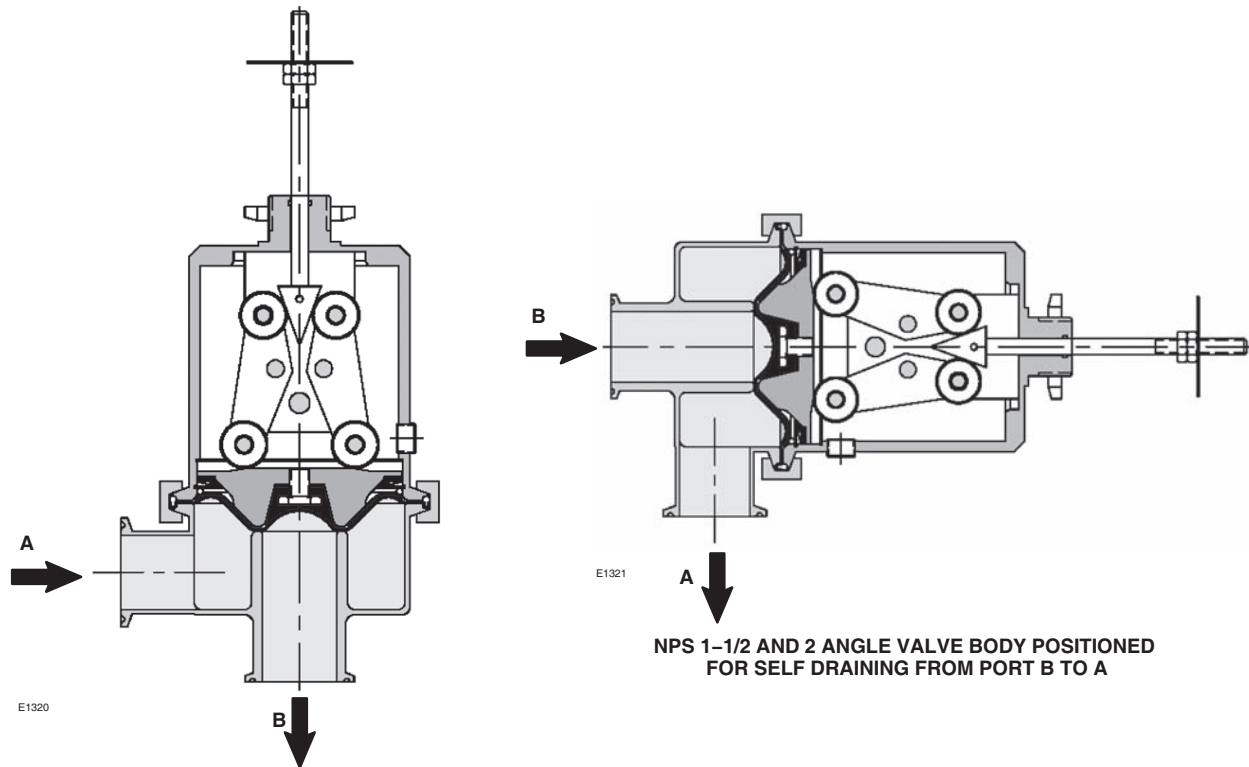

**NPS 1-1/2 AND 2 ANGLE VALVE BODY (RECOMMENDED FOR PROCESSES WHERE ATMOSPHERIC OR SLIGHT VACUUM IS PRESENT DOWNSTREAM OF PORT B [PORTS A AND B MUST BE DRAINED SEPARATELY])**

**NPS 1-1/2 AND 2 ANGLE VALVE BODY POSITIONED FOR SELF DRAINING FROM PORT B TO A**

*Figure 9. NPS 1 Angle and Inline Valve Body Orientations*

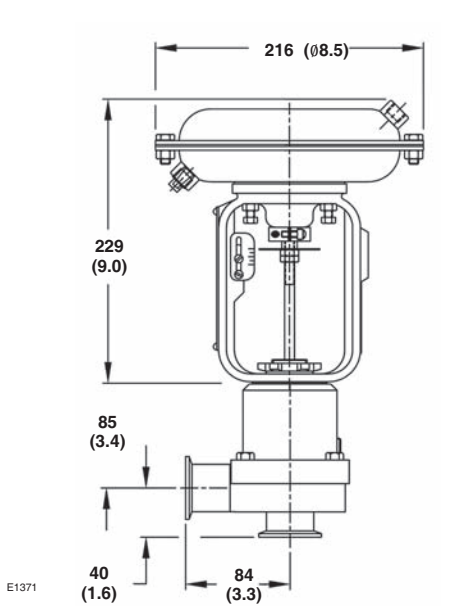

E1371

84000 ANGLE VALVE BODY WITH BAUMANN 32 ACTUATOR ATO/FC ACTION

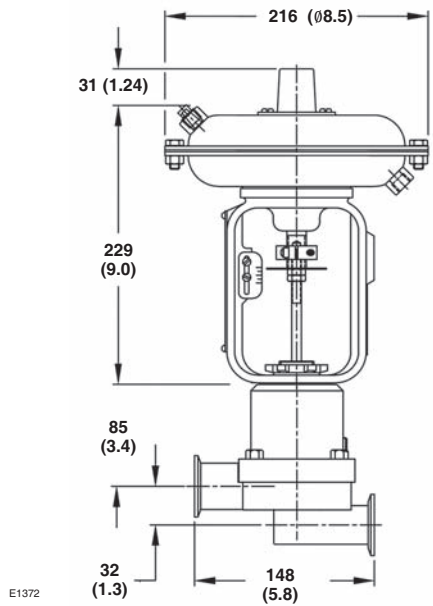

E1372

84000 INLINE VALVE BODY WITH BAUMANN 32 ACTUATOR ATC/FO ACTION, DUAL STOP

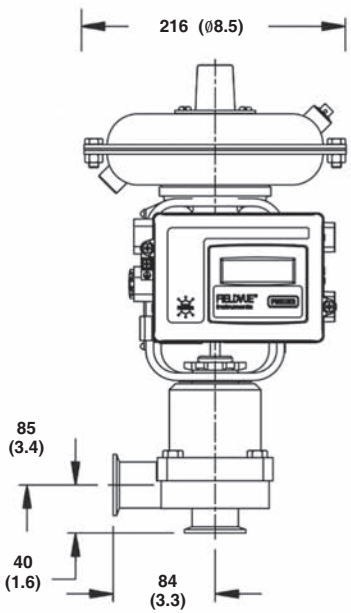

84000 ANGLE VALVE BODY WITH BAUMANN 32 ACTUATOR ATC/FO ACTION, DUAL STOP AND FIELDVUE DVC2000 DIGITAL VALVE CONTROLLER

E1322

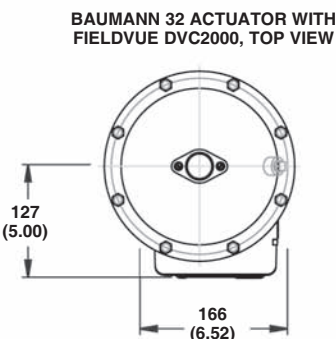

BAUMANN 32 ACTUATOR WITH FIELDVUE DVC2000, TOP VIEW

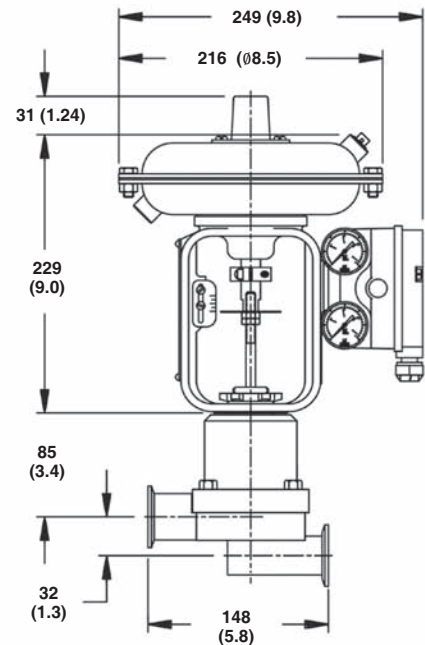

84000 INLINE VALVE BODY WITH BAUMANN 32 ACTUATOR ATC/FO ACTION, DUAL STOP AND 3660/3661 POSITIONER

NOTE: ACTUATOR REMOVAL REQUIRES 115mm (4.5 INCHES) VERTICAL CLEARANCE. FOR PROPER ADJUSTMENTS TO DUAL TRAVEL STOPS, REFER TO ACTUATOR INSTRUCTIONS

mm (inch)

Figure 10. Dimensional Drawings for Baumann 84000 NPS 1 Angle and Inline Valves

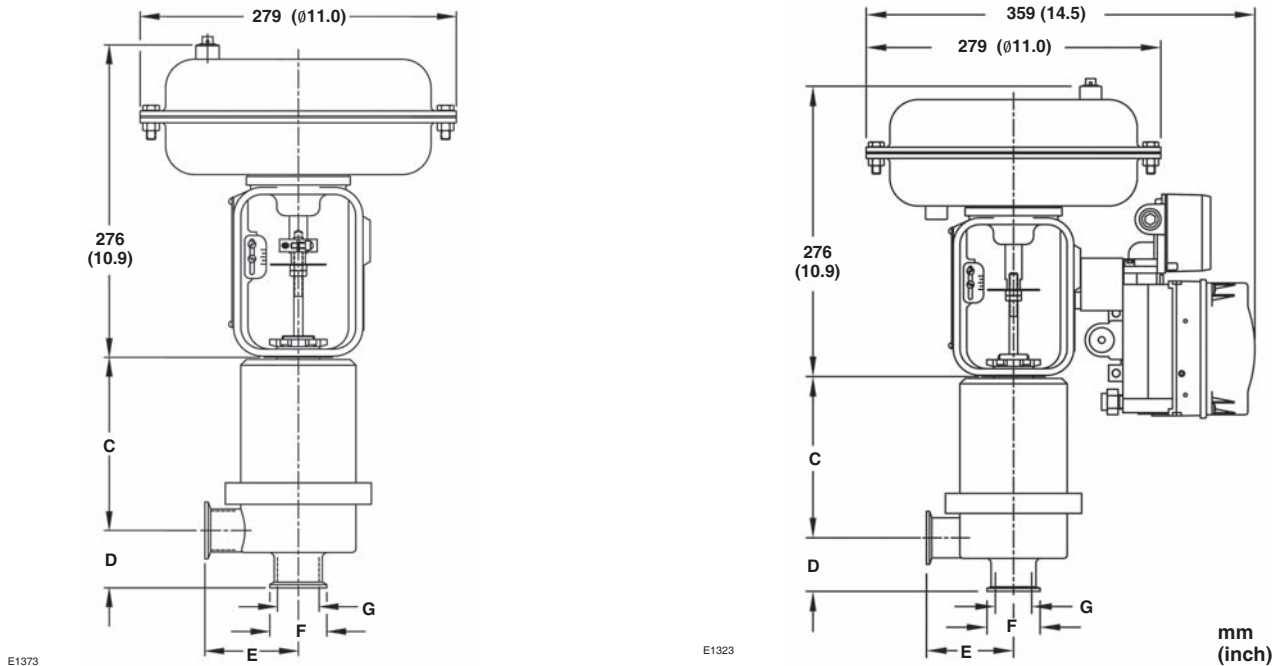

NOTE: ACTUATOR REMOVAL REQUIRES 115mm (4.5 INCHES) VERTICAL CLEARANCE. FOR PROPER ADJUSTMENTS TO DUAL TRAVEL STOPS, REFER TO ACTUATOR INSTRUCTIONS

Figure 11. Dimensional Drawing for Baumann 84000 NPS 1-1/2 and 2 Angle Valve with FIELDVUE DVC6010 Digital Valve Controller

Table 2. Dimensions for NPS 1-1/2 and 2 Angle Valve Body

VALVE SIZE	C		D		E		F		G	
	mm	Inch	mm	Inch	mm	Inch	mm	Inch	mm	Inch
1-1/2	152.4	6.0	50.8	2.00	82.55	3.25	50.39	1.984	34.44	1.356
2	160	6.3	50.8	2.00	88.9	3.50	63.9	2.516	47.63	1.875

Table 3. Weights, Valve Assemblies, and Actuators

VALVE SIZE	84000 ANGLE ASSY		84000 INLINE ASSY		ACTUATOR WEIGHTS		
	lbs	kg	lbs	kg	TYPE	lbs	kg
1	9.0	4.08	9.5	4.31	32	10	4.5
1-1/2	11.5	5.22	N/A		54	25	11.3
2	11.5	5.22	N/A				

Baumann, Fisher, and FIELDVUE are marks owned by one of the companies in the Emerson Process Management business division of Emerson Electric Co. Emerson Process Management, Emerson, and the Emerson logo are trademarks and service marks of Emerson Electric Co. All other marks are the property of their respective owners.

The contents of this publication are presented for informational purposes only, and while every effort has been made to ensure their accuracy, they are not to be construed as warranties or guarantees, express or implied, regarding the products or services described herein or their use or applicability. All sales are governed by our terms and conditions, which are available upon request. We reserve the right to modify or improve the designs or specifications of such products at any time without notice. Neither Emerson, Emerson Process Management, nor any of their affiliated entities assumes responsibility for the selection, use or maintenance of any product. Responsibility for proper selection, use, and maintenance of any product remains solely with the purchaser and end user.

**Emerson Process Management**

Marshalltown, Iowa 50158 USA  
 Sorocaba, 18087 Brazil  
 Chatham, Kent ME4 4QZ UK  
 Dubai, United Arab Emirates  
 Singapore 128461 Singapore  
 www.Fisher.com

