

# Fisher® D4 Control Valve Assembly

## Contents

Introduction .....	1
Scope of Manual .....	1
Description .....	1
Specifications .....	2
Educational Services .....	2
Installation .....	4
Spring Adjustment .....	5
Maintenance .....	6
Valve Plug and Seat Ring .....	6
Valve Packing .....	8
Actuator .....	10
Parts Ordering .....	14
Repair Kits .....	17
Parts List .....	17
Appendix A .....	19

Figure 1. Fisher D4 Control Valve



W8531

## Introduction

### Scope of Manual

This instruction manual provides installation, maintenance, and parts information for the Fisher D4 control valve.

Do not install, operate, or maintain a D4 control valve without being fully trained and qualified in valve, actuator, and accessory installation, operation, and maintenance. **To avoid personal injury or property damage, it is important to carefully read, understand, and follow all the contents of this manual, including all safety cautions and warnings.** If you have any questions about these instructions, contact your Emerson Process Management sales office before proceeding.

### Description

The D4 control valve is a compact, rugged valve designed primarily for high-pressure throttling applications. This valve is ideal for use on pressure and flow control applications within the oil and gas production industry. The D4 valve also makes an excellent dump valve for high-pressure separators and scrubbers.

The D4 control valve meets the metallurgical requirements of NACE MR0175/ISO 15156 without environmental limits for temperatures below 135°C (275°F). If the temperature is above 135°C (275°F), the N07718 Belleville washers will impose some limits, as shown in table 3.



Table 1. Specifications

<b>Available Configurations</b> Spring-to-Close Spring-to-Open	<b>Material Temperature Capabilities<sup>(1)</sup></b> <b>Actuator Assembly:</b> -40 to 93°C (-40 to 200°F) <b>Valve Body Assembly:</b> <i>Standard Bonnet O-Ring:</i> -40 to 135°C (-40 to 275°F) <i>Optional Fluorocarbon Bonnet O-Ring:</i> -23 to 204°C (-10 to 400°F)
<b>Valve Body Sizes and End Connection Styles<sup>(1)</sup></b> See table 2	<b>Flow Characteristic</b> Equal percentage
<b>Maximum Inlet Pressures and Temperatures<sup>(1)</sup></b> If the valve nameplate shows an ASME pressure-temperature class, maximum inlet pressure and temperature is consistent with the applicable class per ASME B16.34. If the nameplate does not show an ASME class, it will show a maximum cold working pressure at 38°C (100°F) (for example, 293 bar [4250 psi])	<b>Flow Direction</b> Flow up only
<b>Maximum Pressure Drops<sup>(1)</sup></b> See tables 4, 5, 6, and 7	<b>Port Diameters</b> See table 2
<b>Input Signal to Actuator</b> See tables 4, 5, 6, and 7	<b>Valve Plug Travel</b> 19 mm (0.75 inch)
<b>Actuator Maximum Casing Pressure<sup>(1)</sup></b> 3.4 bar (50 psig)	<b>Valve Plug Style</b> Micro-Form valve plug
<b>Shutoff Classification per ANSI/FCI 70-2 and IEC 60534-4</b> Class IV	<b>Actuator Diaphragm Effective Area</b> 452 cm <sup>2</sup> (69 inches <sup>2</sup> )
	<b>Actuator Pressure Connection Size</b> 1/4 NPT internal

1. The pressure or temperature limits in the referenced tables and any applicable ASME code limitations should not be exceeded.

## Specifications

Table 1 lists specifications for the D4 control valve. Some of the specifications for a given control valve as it originally comes from the factory are stamped on a nameplate located on the actuator spring barrel.

## Educational Services

For information on available courses for Fisher D4 valves, as well as a variety of other products, contact:

Emerson Process Management  
Educational Services, Registration  
P.O. Box 190; 301 S. 1<sup>st</sup> Ave.  
Marshalltown, IA 50158-2823  
Phone: 800-338-8158 or  
Phone: 641-754-3771  
FAX: 641-754-3431  
e-mail: education@emerson.com

Table 2. Valve Sizes and Connection Styles

VALVE SIZE, NPS	PORT DIAMETER, (INCHES)	SCREWED	RAISED FACE (RF) FLANGED				RING TYPE JOINT (RTJ) FLANGED	
		4250 psi	CL150	CL300	CL600	CL900 and CL1500	CL600	CL900 and CL1500
1	0.25, 0.375, 0.5, 0.75	X	X	X	X	X	X	X
2	0.25, 0.375, 0.5, 0.75, 1, 1.25	X	X	X	X	X	X	X

X = Available construction.

Table 3. D4 Environmental Limits for NACE MR0175/ISO 15156 with Sour Trim

MAXIMUM TEMPERATURE		MAXIMUM H <sub>2</sub> S PARTIAL PRESSURE		COMPATIBLE WITH ELEMENTAL SULFUR?
°C	°F	MPa	psia	
232	450	0.2	30	No
204	400	1.4	200	No
199	390	2.3	330	No
191	375	2.5	360	No
149	300	2.8	400	No
135	275	No Limit		Yes

Table 4. Maximum Shutoff Pressure Drops<sup>(1)</sup> for Fisher D4 Control Valves (Spring-to-Close) When Used with Typical Control Instrumentation<sup>(2)</sup>

INPUT SIGNAL TO ACTUATOR		0 to 1.2 Bar (0 to 18 Psig)		0 to 1.4 Bar (0 to 20 Psig)		0 to 2.0 Bar (0 to 30 Psig)		0 to 2.3 Bar (0 to 33 Psig)		0 to 2.4 Bar (0 to 35 Psig)		0 to 3.4 Bar (0 to 50 Psig)	
SPRING		Light Rate						Heavy Rate					
INITIAL SPRING SETTING		0.77 Bar (11.2 Psig)		0.77 Bar (11.2 Psig)		0.85 Bar (12.4 Psig)		1.05 Bar (15.3 Psig)		1.18 Bar (17.1 Psig)		1.18 Bar (17.1 Psig)	
PORT DIAMETER		Maximum Pressure Drop											
mm	Inches	Bar	Psi	Bar	Psi	Bar	Psi	Bar	Psi	Bar	Psi	Bar	Psi
6.4	0.25	293 <sup>(3)</sup>	4250 <sup>(3)</sup>	293 <sup>(3)</sup>	4250 <sup>(3)</sup>	293	4250	293	4250	293	4250	293	4250
9.5	0.375	293 <sup>(3)</sup>	4250 <sup>(3)</sup>	293 <sup>(3)</sup>	4250 <sup>(3)</sup>	293	4250	293	4250	293	4250	293	4250
12.7	0.5	191	2765	191	2765	219	3180	288	4180	293	4250	293	4250
19.1	0.75	80	1160	80	1160	92	1340	123	1785	143	2080	143	2080
25.4	1	42	610	42	610	49	715	67	965	78	1130	78	1130
31.8	1.25	25	365	25	365	30	430	41	590	48	700	48	700

1. The pressure or temperature limits in the referenced tables and any applicable ASME code limitations should not be exceeded.  
 2. For example, use the column marked 0-1.4 bar (0-20 psig) for a 0.21-1.0 bar (3-15 psig) pneumatic controller with 1.4 bar (20 psig) supply pressure.  
 3. For applications with downstream pressure in excess of 196 bar (2845 psig), use 196 bar (2845 psig) for Maximum Shutoff Pressure.

Table 5. Maximum Shutoff Pressure Drops<sup>(1)</sup> for Fisher D4 Control Valves (Spring-to-Close) When Used with Instrumentation with Restricted Output Range<sup>(2)</sup>

INPUT SIGNAL TO ACTUATOR		0.4 to 2.0 Bar (6 to 30 Psig)				0.14 to 2.3 Bar (2 to 33 Psig)			
SPRING		Heavy Rate				Heavy Rate			
INITIAL SPRING SETTING		0.97 Bar (14.0 Psig)				1.17 Bar (17.0 Psig)			
PORT DIAMETER		Maximum Pressure Drop							
mm	Inches	Bar		Psi		Bar		Psi	
6.4	0.25	293 <sup>(3)</sup>		4250 <sup>(3)</sup>		293		4250	
9.5	0.375	210 <sup>(3)</sup>		3045 <sup>(3)</sup>		293		4250	
12.7	0.5	113		1635		282		4095	
19.1	0.75	45		655		120		1750	
25.4	1	23		330		65		945	
31.8	1.25	13		185		39		580	

1. The pressure or temperature limits in the referenced tables and any applicable ASME code limitations should not be exceeded.  
 2. For example, an Electro-Pneumatic Transducer calibrated for 0.4-2.0 bar (6-30 psig) output pressure.  
 3. For applications with downstream pressure in excess of 118 bar (1715 psig), use 118 bar (1715 psig) for Maximum Shutoff Pressure.

**Table 6. Maximum Shutoff Pressure Drops<sup>(1)</sup> for Fisher D4 Control Valves (Spring-to-Open) When Used with Typical Control Instrumentation<sup>(2)</sup>**

INPUT SIGNAL TO ACTUATOR		0 to 1.2 Bar (0 to 18 Psig)		0 to 1.4 Bar (0 to 20 Psig)		0 to 2.0 Bar (0 to 30 Psig)		0 to 2.3 Bar (0 to 33 Psig)		0 to 2.4 Bar (0 to 35 Psig)		0 to 3.4 Bar (0 to 50 Psig)	
SPRING		Light Rate						Heavy Rate					
INITIAL SPRING SETTING		0.23 Bar (3.4 Psig)		0.23 Bar (3.4 Psig)		0.28 Bar (4.0 Psig)		0.28 Bar (4.0 Psig)		0.28 Bar (4.0 Psig)		0.28 Bar (4.0 Psig)	
PORT DIAMETER		Maximum Pressure Drop											
mm	Inches	Bar	Psi	Bar	Psi	Bar	Psi	Bar	Psi	Bar	Psi	Bar	Psi
6.4	0.25	293 <sup>(3)</sup>	4250 <sup>(3)</sup>	293 <sup>(3)</sup>	4250 <sup>(3)</sup>	293	4250	293	4250	293	4250	293	4250
9.5	0.375	293 <sup>(3)</sup>	4250 <sup>(3)</sup>	293 <sup>(3)</sup>	4250 <sup>(3)</sup>	293	4250	293	4250	293	4250	293	4250
12.7	0.5	187	2715	233	3380	293	4250	293	4250	293	4250	293	4250
19.1	0.75	78	1135	99	1430	147	2130	178	2575	198	2875	293	4250
25.4	1	41	600	53	765	80	1160	97	1410	109	1575	195	2830
31.8	1.25	24	355	32	465	49	715	60	875	68	985	123	1785

1. The pressure or temperature limits in the referenced tables and any applicable ASME code limitations should not be exceeded.  
2. For example, use the column marked 0-1.4 bar (0-20 psig) for a 0.21-1.0 bar (3-15 psig) pneumatic controller with 1.4 bar (20 psig) supply pressure.  
3. For applications with downstream pressure in excess of 190 bar (2760 psig), use 190 bar (2760 psig) for Maximum Shutoff Pressure.

**Table 7. Maximum Shutoff Pressure Drops<sup>(1)</sup> for Fisher D4 Control Valves (Spring-to-Open) When Used with Instrumentation with Restricted Output Range<sup>(2)</sup>**

INPUT SIGNAL TO ACTUATOR		0.4 to 2.0 Bar (6 to 30 Psig)				0.14 to 2.3 Bar (2 to 33 Psig)			
SPRING		Heavy Rate							
INITIAL SPRING SETTING		0.69 Bar (10.0 Psig)				0.42 Bar (6.1 Psig)			
PORT DIAMETER		Maximum Pressure Drop							
mm	Inches	Bar		Psi		Bar		Psi	
6.4	0.25	293 <sup>(3)</sup>		4250 <sup>(3)</sup>		293		4250	
9.5	0.375	293 <sup>(3)</sup>		4250 <sup>(3)</sup>		293		4250	
12.7	0.5	196		2845		293		4250	
19.1	0.75	82		1195		156		2265	
25.4	1	43		630		85		1235	
31.8	1.25	26		380		52		765	

1. The pressure or temperature limits in the referenced tables and any applicable ASME code limitations should not be exceeded.  
2. For example, an Electro-Pneumatic Transducer calibrated for 0.4-2.0 bar (6-30 psig) output pressure.  
3. For applications with downstream pressure in excess of 202 bar (2925 psig), use 202 bar (2925 psig) for Maximum Shutoff Pressure.

## Installation

### **⚠ WARNING**

Always wear protective gloves, clothing, and eyewear when performing any installation operations to avoid personal injury.

To avoid personal injury or property damage caused by bursting of pressure-retaining parts or by uncontrolled process fluid, be certain the service conditions do not exceed the limits shown on the valve nameplate and in tables 1, 4, 5, 6, and 7. Use pressure-relieving devices required by government or accepted industry codes and good engineering practices.

Check with your process or safety engineer for any additional measures that must be taken to protect against process media.

If installing into an existing application, also refer to the WARNING at the beginning of the Maintenance section in this instruction manual.

**⚠ WARNING**

When ordered, the valve configuration and construction materials were selected to meet particular pressure, temperature, pressure drop, and controlled fluid conditions. Responsibility for the safety of process media and compatibility of valve materials with process media rests solely with the purchaser and end-user. Since some body/trim material combinations are limited in their pressure drop and temperature ranges, do not apply any other conditions to the valve without first contacting your Emerson Process Management sales office.

**⚠ WARNING**

Avoid personal injury or property damage caused by possible actuator failure. The use of a rigidly-mounted support on the actuator casing may cause additional stress on the actuator leading to premature wear and/or failure of the actuator components.

**CAUTION**

To avoid product damage, inspect the valve before installation for any damage or any foreign material that may have collected in the valve body. Also remove any pipe scale, welding slag, or other foreign material from the pipeline.

1. Before installing the control valve assembly, inspect it for any damage and for any foreign material that may have collected in the valve body.
2. Remove any pipe scale, welding slag, and other foreign material from the pipeline.
3. The control valve can be installed in any position, but normally the actuator is vertical above the valve. Install the valve so the flow direction arrow on the side of the valve indicates the direction of the process flow.
4. Install the valve following local and national piping codes when they apply to the application. For screwed connections, treat the external pipe threads with a good grade pipe compound. For flanged valves, use suitable gaskets between valve and pipeline flanges.
5. If continuous operation is required during maintenance and inspection, install a conventional three-valve bypass around the valve.
6. Connect loading pressure for the Spring-to-Open configuration to the 1/4-18 NPT connection in the upper casing assembly (key 23) as shown in figure 5. The Spring-to-Close configuration loading pressure connection is in the lower casing assembly (key 39) as shown in figure 4.

## Spring Adjustment

The spring has a fixed pressure span over which loading pressure will stroke the valve. Adjustment of the spring compression shifts the span so that more or less loading pressure is required to start travel. Since the span does not change, there will be a corresponding increase or decrease in the pressure requirements at the end of the valve stroke.

In order to maximize shutoff pressure drop values, the actuator spring must be accurately adjusted for each Input Signal Pressure Range. If the actuator has been disassembled or pressure conditions have changed, the spring may require adjustment. Refer to tables 2 and 4 to determine the Initial Spring Set values based on the Input Signal range that is available to the actuator. These values include packing friction.

## Spring-to-Close

Refer to figure 4.

1. Loosen the adjusting screw nut (key 44).
2. Turn the adjusting screw (key 31) clockwise to compress the spring or counterclockwise to decrease spring compression.
3. After adjustment, tighten the adjusting screw nut (key 44).

## Spring-to-Open

Refer to figure 5.

1. Unscrew the spring case assembly (key 27).
2. Turn the adjusting stem nut (key 44) clockwise to compress the spring or counterclockwise to decrease spring compression.
3. After adjustment, replace the spring case assembly (key 27).

## Maintenance

Refer to figure 4.

Valve parts are subject to normal wear and must be inspected and replaced as necessary. The frequency of inspection and maintenance depends on the severity of the service conditions.

### **⚠ WARNING**

**Avoid personal injury from sudden release of process pressure or bursting of parts. Before performing any maintenance operations:**

- Do not remove the actuator from the valve while the valve is still pressurized.
- Always wear protective gloves, clothing, and eyewear when performing any maintenance operations to avoid personal injury.
- Disconnect any operating lines providing air pressure, electric power, or a control signal to the actuator. Be sure the actuator cannot suddenly open or close the valve.
- Use bypass valves or completely shut off the process to isolate the valve from process pressure. Relieve process pressure on both sides of the valve. Drain the process media from both sides of the valve.
- Vent the power actuator loading pressure and relieve any actuator spring precompression.
- Use lock-out procedures to be sure that the above measures stay in effect while you work on the equipment.
- The valve packing box may contain process fluids that are pressurized, *even when the valve has been removed from the pipeline*. Process fluids may spray out under pressure when removing the packing hardware or packing rings.
- Check with your process or safety engineer for any additional measures that must be taken to protect against process media.

## Valve Plug and Seat Ring

The D4 control valve is designed to allow easy access to the valve plug and seat ring without disturbing the packing. Refer to other sections of this instruction manual if additional maintenance is required.

## Disassembly

1. Remove the loading pressure tubing and any accessories that may hamper disassembly.
2. Break the hammer nut (key 6) loose with a hammer. Continue turning the hammer nut by using a hammer or a large adjustable wrench, tightened around one ear of the hammer nut. If the bonnet is stuck on the valve, continue to unscrew the hammer nut. The hammer nut will contact the spring pins (key 7) and will force the bonnet out of the valve. Carefully lift the actuator, bonnet, and valve plug assembly from the valve body.

### **⚠ WARNING**

The spring pins must always be in place during valve operation. They provide a safeguard against injury when the unit is being disassembled.

3. Use a socket wrench to loosen the seat ring (key 3).
4. Remove the seat ring (key 3) and seat ring gasket (key 9) from the valve body.
5. Inspect parts for wear or damage that would prevent proper operation of the valve body. Carefully clean the seat ring gasket surfaces and seat ring threads.

### **⚠ WARNING**

Be careful to avoid damaging the seating surface on the valve plug or seat ring as damage in these areas will allow excessive leakage at shutoff. Avoid damaging the highly polished valve stem surface. A damaged valve stem could cut the packing and allow process fluid to leak to the atmosphere.

Table 8. Torque for Seat Ring (Key 3)

VALVE SIZE	RECOMMENDED TORQUE	
	NPS	
1	N•m	Lbf•ft
1	407	300
2	698	515

6. **For spring-to-close only:** To remove the valve plug (key 2), drive out the groove pin (key 4) and unscrew the valve plug from the stem (key 47). If the groove pin (key 4) is not exposed, verify that downward movement of the stem is not restricted by instrument linkages attached to the stem (key 47).

If the valve plug cannot be easily unscrewed from the stem, use a punch to keep the stem from turning as the plug is removed.

7. **For spring-to-open only:** To remove the valve plug (key 2), first remove the spring case assembly (key 27). Remove the adjustment screw nut (key 44), the upper spring seat (key 29), and the spring (key 30). Push the adjustment stem (key 31) fully downward until the diaphragm plate (key 40) contacts the cap screws (key 38), exposing the groove pin (key 4) in the plug. If the groove pin (key 4) is not exposed, verify that downward movement of the stem is not restricted by instrument linkages attached to the stem (key 47). Drive out the groove pin (key 4) and unscrew the valve plug from the stem (key 47).

If the valve plug cannot be easily unscrewed from the stem, use a punch to keep the stem from turning as the plug is removed.

## Assembly

1. Make sure the bonnet O-ring (key 8) is on the bonnet and lubricated with lithium grease (key 49).

2. Install the plug (key 2) on the stem (key 47) and insert a new groove pin (key 4).
3. Thoroughly clean the seat ring and bonnet threads in the valve body (key 1). Also clean the valve body seat ring gasket surfaces.
4. Apply anti-seize lubricant (key 54) to the threads of the seat ring (key 3), and its mating threads in the valve body.
5. Apply anti-seize lubricant (key 54) to the seat ring gasket (key 9) and install into the valve body.
6. Screw the seat ring into the valve body. Use a socket wrench to tighten the seat ring to the torque values shown in table 8. Remove all excess lubricant after tightening.
7. Lubricate (key 54) the threads on the valve body and hammer nut and the contact surfaces of the bonnet and hammer nut flange. Install the bonnet and actuator assembly with pinned valve plug onto the valve body. Tighten the hammer nut using an adjustable wrench until the nut stops turning. A few hammer blows will be required to ensure that the assembly is tight.
8. See the actuator assembly and spring adjustment sections of this manual.

## Valve Packing

---

### Note

These instructions apply to valves manufactured with serial numbers equal to and greater than 18679262. See Appendix A for information on packing constructions with serial numbers less than 18679262.

If your D4 valve assembly has a packing retainer lock ring (see figure 6), proceed to Appendix A.

---

### WARNING

**Observe the warning at the start of the Maintenance section.**

---

The valve stem packing can only be accessed from within the valve body. If packing maintenance is required, first disassemble per steps 1, 2, and 6 or 7 in the Valve Plug and Seat Ring Disassembly section of this document.

## Disassembly

1. Unscrew the packing retainer (key 10) from the bonnet (key 5).
2. Remove the five Belleville springs (key 11), packing spacer (key 14), packing (key 13), and two anti-extrusion rings (key 12) from the bonnet, using a formed wire hook.
3. Clean and inspect the packing box wall to ensure that the packing surfaces are not damaged. If the surface condition is damaged, and cannot be improved by light sanding, replace the bonnet by contacting your Emerson Process Management sales office.
4. Inspect the valve stem for scratches or wear, and valve plug for wear or damage. Replace if necessary.



Figure 2. Fisher D4 Packing Installation

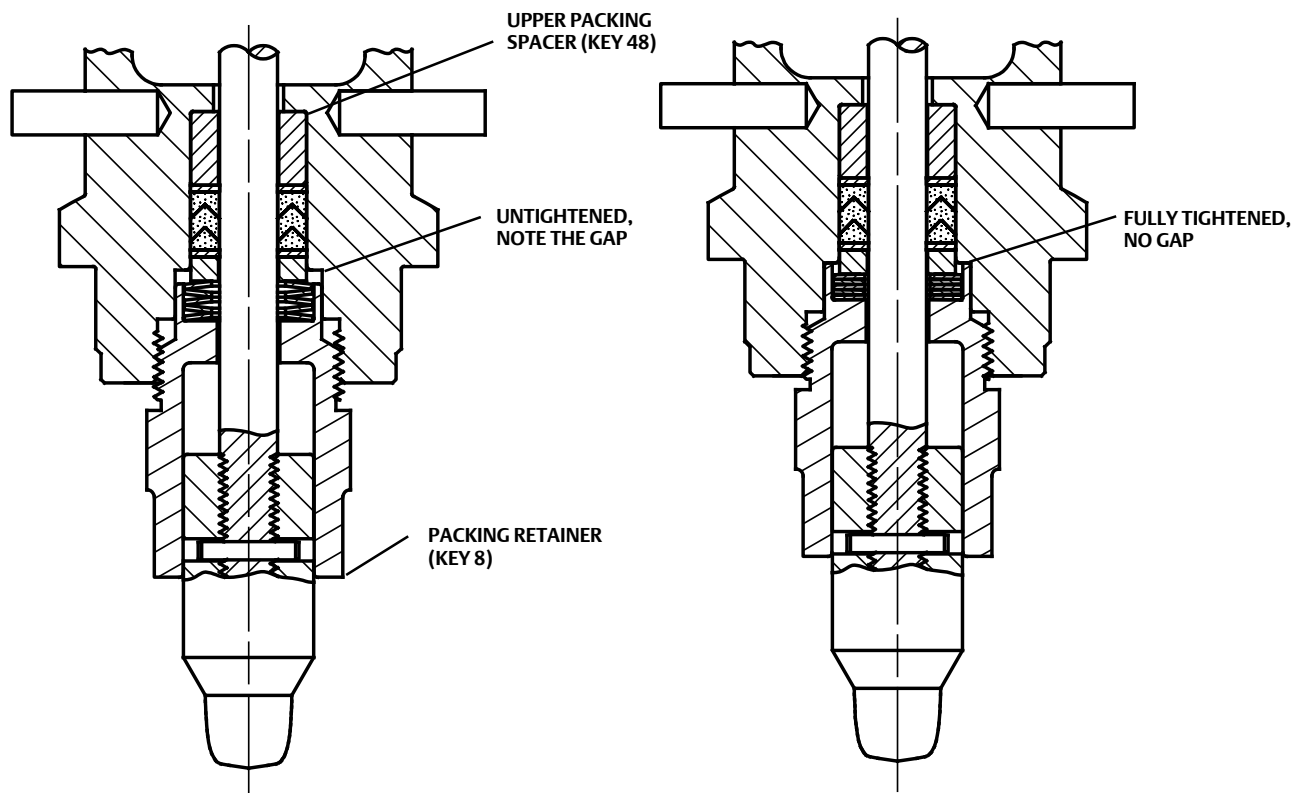

BELLEVILLE SPRINGS FULLY ENCLOSED BY THE PACKING RETAINER

VALVE PLUG, BELLEVILLE SPRINGS, AND PACKING RETAINER CORRECTLY INSTALLED AND TIGHTENED

Figure 3. Lubrication Locations on Packing

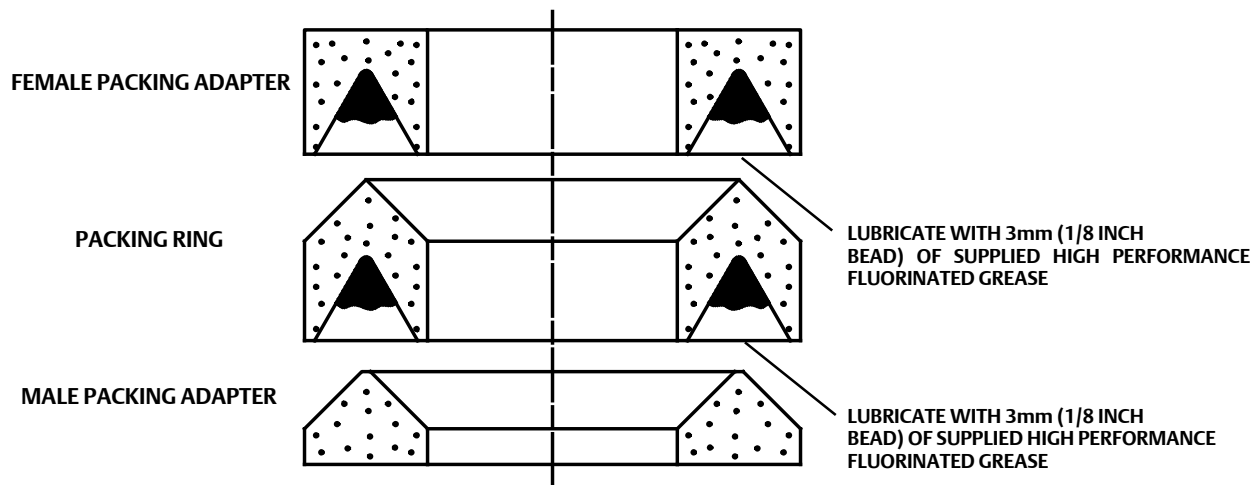

## Assembly

Refer to figures 2, 3, 4, and 5.

---

### Note

If your D4 valve assembly has a packing retainer lock ring (see figure 6), proceed to Appendix A.

---

1. Ensure the upper packing spacer (key 48) is installed, as shown in figure 2.
2. Using a non-marring installation tool, such as a 12-inch length of 1/2 inch PVC pipe, push the first anti-extrusion washer (key 12) fully into the packing box by hand. Then, use the packing spacer (key 14) to fully seat the anti-extrusion washer by firmly tapping the packing spacer against the anti-extrusion washer with a hammer and the PVC pipe.
3. Remove the packing spacer from the packing bore.

### CAUTION

**All D4 packing kits include a single use packet of high performance fluorinated grease. This is the only acceptable D4 packing lubricant.**

---

### Note

In the following procedure, carefully install each packing ring individually over the valve stem and push completely into the packing box with a non-marring tube. A 12-inch length of 1/2 inch PVC pipe works well for this. It is recommended that the lubricated packing rings be installed individually rather than pushed in as a set.

---

4. Apply a 3mm (1/8 inch) bead of the supplied high performance fluorinated grease (key 44) around the groove of the female packing adaptor as shown in figure 3 and install over the valve stem (key 16).
5. Apply a 3mm (1/8 inch) bead of the supplied high performance fluorinated grease (key 44) around the groove of the packing ring as shown in figure 3 and install over the valve stem.
6. Install the male packing adaptor, lower anti-extrusion washer (key 10), and lower packing spacer over the valve stem as shown in figure 2.
7. Firmly press all packing parts into the packing bore with a tube.
8. Install the five Belleville springs (key 11) over the valve stem. The Belleville springs should be single-stacked with the inside diameter of the inner spring contacting the packing spacer (key 14), and the outside diameter of the outer spring contacting the packing retainer (key 10).
9. Lubricate the threads of the packing retainer with anti-seize and install into the bonnet using a 1-5/8 inch wrench. Make sure the Belleville springs are completely enclosed by the packing retainer as shown in figure 2.
10. Torque the packing retainer to 136 N•m (100 lbf•ft). The packing retainer has been installed correctly when a metal-to-metal contact has been made between the packing retainer end and the bonnet (key 5). The packing retainer threads should be completely enclosed by the bonnet.

## Actuator (Spring-to-Close)

### ⚠ WARNING

**Observe the warning at the start of the Maintenance section.**

---

Refer to figure 4.

Before disassembling the actuator, disassemble the valve plug, seat ring, and packing according to instructions in this manual.

## Disassembly

1. Loosen the adjusting screw nut (key 44) and turn the adjusting screw (key 31) counterclockwise to remove all spring compression.
2. Unscrew the casing cap screws and hex nuts (keys 45 and 46), and remove the upper casing assembly (key 23) from the lower casing (key 39).
3. Remove the spring seat (key 29) and actuator spring (key 30).
4. Lift out the diaphragm, diaphragm plate, and stem assembly. Remove the travel indicator (key 32) when the bottom of the stem enters the yoke window.
5. To replace the diaphragm (key 15), separate the diaphragm assembly by using a wrench on the hex nuts (key 42) to unscrew the assembly.
6. Separate the parts--diaphragm washer, actuator O-ring (keys 41 and 25), diaphragm, and diaphragm plate, (keys 15 and 40).
7. Inspect the diaphragm and the actuator O-ring for damage or deterioration, and replace if necessary. If the diaphragm is replaced, a new O-ring should also be installed.
8. Inspect the stem O-ring (key 19) and bonnet bushing (key 20); replace if necessary. To inspect the casing O-ring (key 18), remove the cap screws (key 38) and lift off the lower casing (key 39). Replace the O-ring if necessary.
9. If the hammer nut needs to be removed from the bonnet, the spring pins (key 7) can be removed with locking pliers.

## Assembly

1. Before starting assembly, make sure all parts are clean and in good condition. There should be no burrs or sharp edges on any threads or surfaces that might cut or damage an O-ring, bushing, the packing, or the diaphragm. When replacing O-rings and bushings, be sure the O-ring or bushing groove is clean and undamaged. Using a general purpose lubricant (key 49), lubricate all bushings and O-rings and the threads of parts that have to pass through the bushings and O-rings.

### CAUTION

**The threads on factory-produced valve stems have been specially machined to avoid O-ring, bushing, or packing damage during trim maintenance. Use of other than a factory-produced valve stem may result in early stem O-ring, bushing, and packing failure.**

---

### Note

Do not lubricate cap screws (key 38) before inserting them in the following procedure.

---

2. Place the hammer nut and spring pins on the bonnet, if removed. Install the casing O-ring (key 18), the stem O-ring (key 19), and the bonnet bushing (key 20). Position the lower casing (key 39) on the bonnet. Insert the nonlubricated cap screws (key 38), and torque to 49 N•m (36 lbf•ft).

### ⚠ WARNING

**The spring pins must always be in place during valve operation. They provide a safeguard against injury when the unit is being disassembled.**

---

3. Assemble the diaphragm plate assembly. Place the patterned side of the diaphragm (key 15) against the diaphragm plate (key 40). Be sure to turn the diaphragm washer (key 41) so that the side that is beveled on the inside diameter is against the O-ring (key 25). Also, make sure that it is assembled for installation with the diaphragm on the loading pressure side and the lockwasher (key 43) and lower spring seat (key 28) are on the spring side.
4. Fasten the diaphragm and diaphragm plate assembly on the stem with hex nuts (key 42). Place the diaphragm and diaphragm plate, and stem assembly into the lower casing and bonnet. Install the travel indicator (key 32) on the stem as the bottom of the stem enters the yoke window.

## CAUTION

**Over-tightening the diaphragm casing cap screws and nuts (keys 45 and 46) can damage the diaphragm. Do not exceed 27 N•m (20 lbf•ft) torque.**

5. Replace the spring (key 30) on the diaphragm plate (key 40). Replace the upper spring seat (key 29). Position the upper casing (key 23) on the lower casing (key 39). Insert the cap screws (key 45) and tighten the hex nuts (key 46). Torque the casing cap screws evenly to 27 N•m (20 lbf•ft) using a crisscross pattern.
6. Adjust the initial spring set per the Spring Adjustment section in this manual.

## Actuator (Spring-to-Open)

### ▲ WARNING

**Observe the warning at the start of the Maintenance section.**

Refer to figure 5.

Before disassembling the actuator, disassemble the valve plug, seat ring, and packing according to instructions in this manual.

## Disassembly

1. Unscrew the spring case assembly (key 27). Turn the adjusting screw nut (key 44) counterclockwise to remove all spring compression. Remove the adjusting screw nut, upper spring seat, and spring (keys 44, 29, and 30)
2. Unscrew the casing cap screws and hex nuts (keys 45 and 46), and remove the upper casing assembly (key 23) from the lower casing (key 39). Remove the cotter pin (key 36) and unscrew the adjusting stem (key 31).
3. Lift out the diaphragm (key 15), diaphragm plate (key 40), and stem assembly. Remove the travel indicator (key 32) when the bottom of the stem enters the yoke window.
4. To replace the diaphragm (key 15), separate the diaphragm assembly by using a wrench on the hex nuts (key 42) to unscrew the assembly.
5. Separate the parts--diaphragm washer, actuator O-ring (keys 41 and 25), diaphragm, and diaphragm plate, (keys 15 and 40).
6. Inspect the diaphragm and the actuator O-ring for damage or deterioration, and replace if necessary. If the diaphragm is replaced, a new O-ring should also be installed.
7. Inspect the stem O-ring (key 19) and bonnet bushing (key 20); replace if necessary. To inspect the casing O-ring (key 18), remove the cap screws (key 38) and lift off the lower casing (key 39). Replace the O-ring if necessary. Inspect the adjusting stem bushing (key 26) and actuator stem O-ring (key 53). Replace if necessary.

8. If the hammer nut needs to be removed from the bonnet, the spring pins (key 7) can be removed with locking pliers.

## Assembly

1. Before starting assembly, make sure all parts are clean and in good condition. There should be no burrs or sharp edges on any threads or surfaces that might cut or damage an O-ring, bushing, the packing, or the diaphragm. When replacing O-rings and bushings, be sure the O-ring or bushing groove is clean and undamaged. Using a general purpose lubricant (key 49), lubricate all bushings and O-rings and the threads of parts that have to pass through the bushings and O-rings.

### CAUTION

**The threads on factory-produced valve stems have been specially machined to avoid O-ring, bushing, or packing damage during trim maintenance. Use of other than a factory-produced valve stem may result in early stem O-ring, bushing, and packing failure.**

#### Note

Do not lubricate cap screws (key 38) before inserting them in the following procedure.

2. Place the hammer nut and spring pins on the bonnet, if removed. Install the casing O-ring (key 18), the stem O-ring (key 19), and the bonnet bushing (key 20). Position the lower casing (key 39) on the bonnet. Insert the nonlubricated cap screws (key 38), and torque to 49 N•m (36 lbf•ft).
3. Assemble the diaphragm plate assembly. Place the patterned side of the diaphragm (key 15) against the diaphragm plate (key 40). Be sure to turn the diaphragm washer (key 41) so that the side that is beveled on the inside diameter is against the O-ring (key 25). Also, make sure that it is assembled for installation with the diaphragm on the loading pressure side and the lockwasher (key 43) and diaphragm washer (key 41) are on the upper side.

### ⚠ WARNING

**The spring pins must always be in place during valve operation. They provide a safeguard against injury when the unit is being disassembled.**

4. Fasten the diaphragm and diaphragm plate assembly on the stem with hex nuts (key 42). Place the diaphragm and diaphragm plate, and stem assembly into the lower casing and bonnet. Install the travel indicator (key 32) on the stem as the bottom of the stem enters the yoke window.
5. Screw the adjusting stem (key 31) onto the stem (key 47) and secure the cotter pin (key 36). Make sure the bushing and O-ring are in place in the upper casing.

### CAUTION

**Over-tightening the diaphragm casing cap screws and nuts (keys 45 and 46) can damage the diaphragm. Do not exceed 27 N•m (20 lbf•ft) torque.**

6. Position the upper casing (key 23) on the lower casing (key 39). Insert the cap screws (key 45) and tighten the hex nuts (key 46). Torque the casing cap screws evenly to 27 N•m (20 lbf•ft) using a crisscross pattern.

7. Replace the spring (key 30), spring seat (key 29), and adjusting stem nut (key 44) over the adjusting stem. Replace the spring case assembly (key 27).
8. Adjust the initial spring set per the Spring Adjustment section in this manual.

## Parts Ordering

Each D4 control valve is assigned a serial number, which can be found on the nameplate. Refer to the number when contacting your Emerson Process Management sales office for assistance or when ordering replacement parts.

### **▲ WARNING**

**Use only genuine Fisher replacement parts. Components that are not supplied by Emerson Process Management should not, under any circumstances, be used in any Fisher valve, because they may void your warranty, might adversely affect the performance of the valve, and could cause personal injury and property damage.**

---

Figure 4. Fisher D4 Valve Assembly (Spring-to-Close)

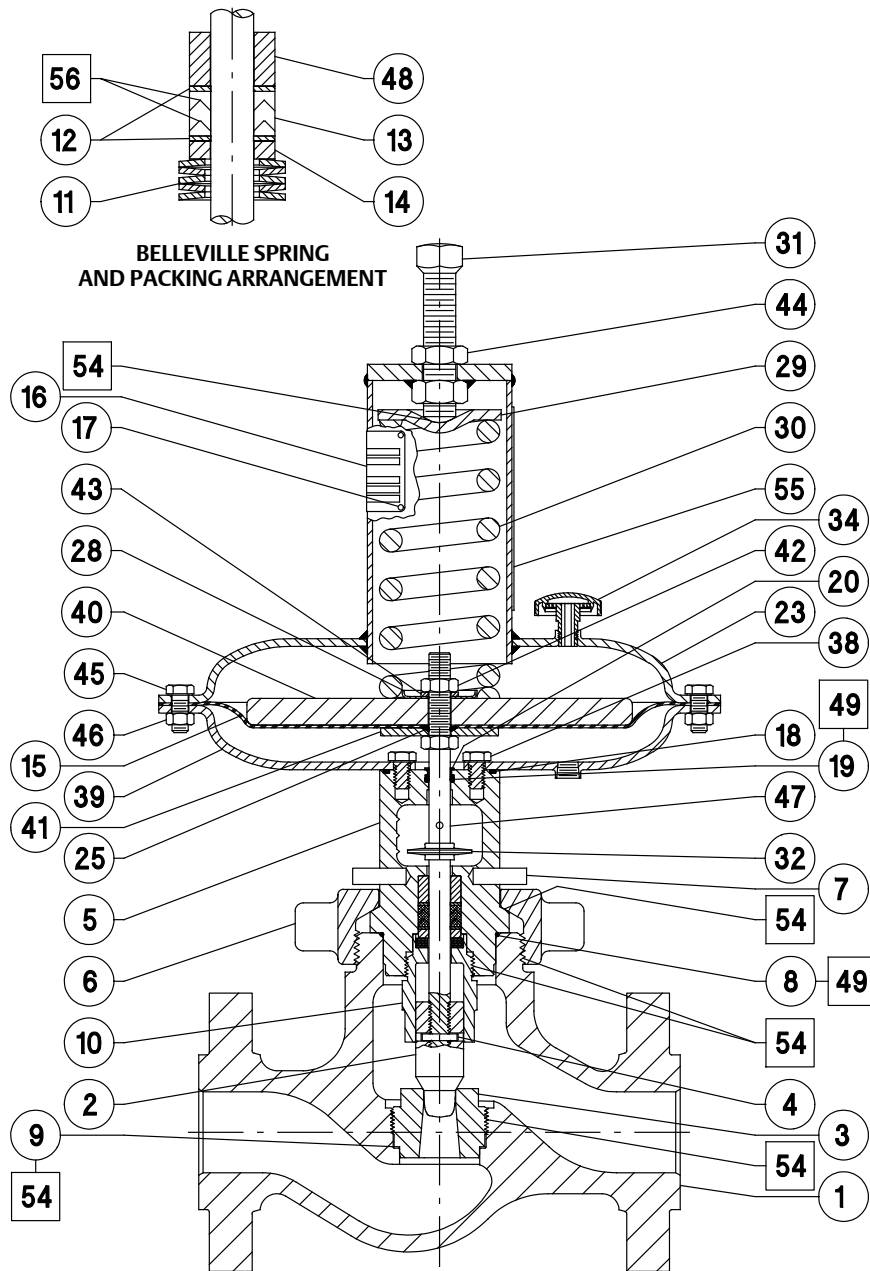

GE02332-C

APPLY LUB

Figure 5. Fisher D4 Valve Assembly (Spring-to-Open)

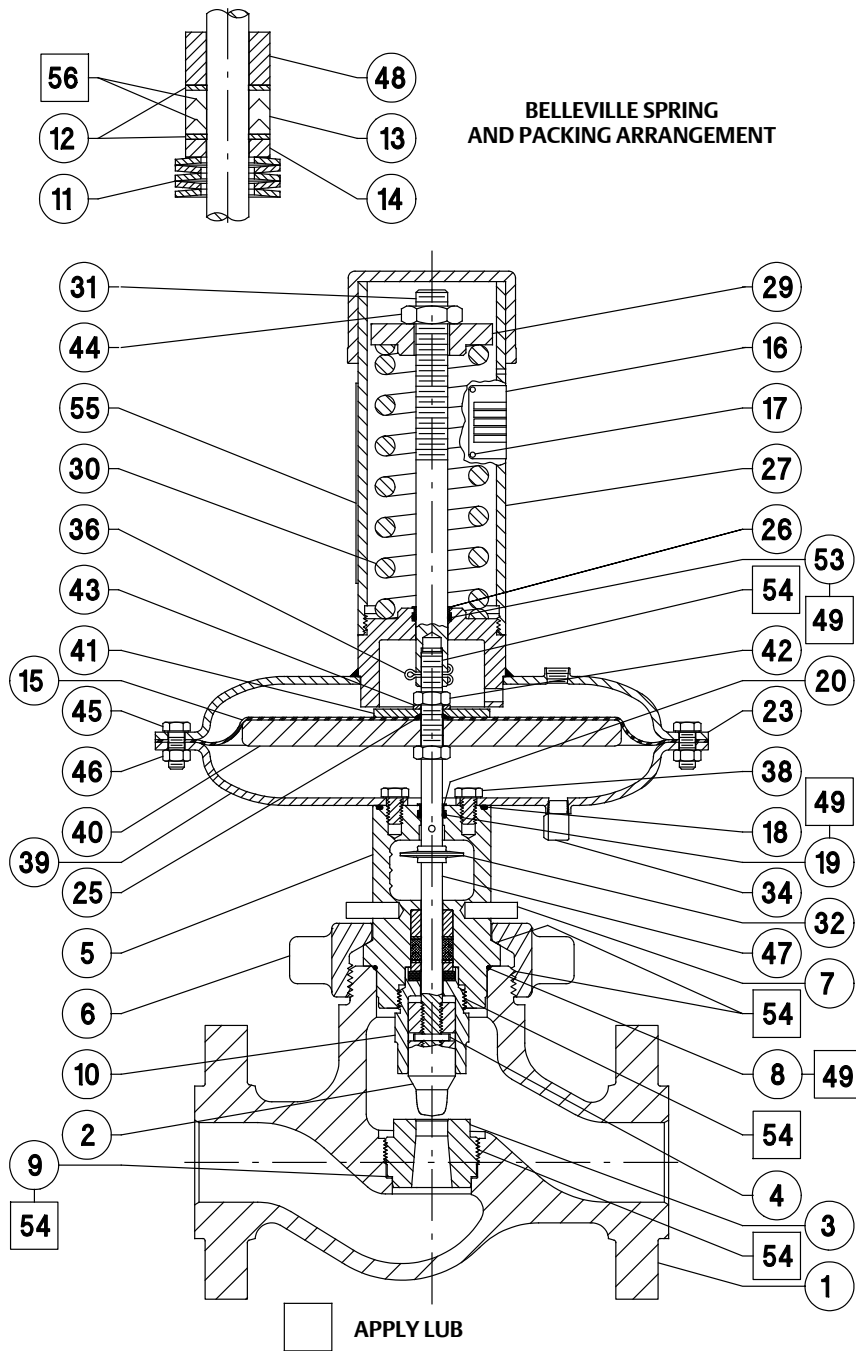

GE02334-E



## Repair Kits

**Note**

All repair kits are supplied with hydrogenated nitrile bonnet O-ring. FKM (fluorocarbon) bonnet O-ring must be ordered separately when required.

Description	Part Number
* Packing Repair Kit Includes key numbers 4, 8, 12 (2 req'd), 13, and high performance fluorinated grease	RD4X0000012
* Actuator Repair Kit Includes key numbers 4, 8, 12 (2 req'd), 13, 15, 18, 19, 20, 25, 26, 36, 53, and high performance fluorinated grease	RD4X0000022

## Parts List

**Note**

For part numbers not shown, contact your Emerson Process Management sales office.

Key	Description	Part Number
1	Valve Body	
2*	Valve Plug	
	S41000 / S41600 HT	
	NPS 1 valve	
	0.25 inch port diameter	20C3692X012
	0.375 inch port diameter	20C3693X012
	0.5 inch port diameter	20C3694X012
	0.75 inch port diameter	GE01557X012
	NPS 2 valve	
	0.25 inch port diameter	GE00992X012
	0.375 inch port diameter	GE00993X012
	0.5 inch port diameter	GE00994X012
	0.75 inch port diameter	GE01558X012
	1-inch port diameter	GE01561X012
	1.25 inch port diameter	GE01555X012
	S17400 H1150 DbI	
	NPS 1 valve	
	0.25 inch port diameter	20C3692X032
	0.375 inch port diameter	20C3693X032
	0.5 inch port diameter	20C3694X032
	0.75 inch port diameter	GE01557X032
	NPS 2 valve	
	0.25 inch port diameter	GE00992X032
	0.375 inch port diameter	GE00993X032
	0.5 inch port diameter	GE00994X032
	0.75 inch port diameter	GE01558X032
	1-inch port diameter	GE01561X032

Key	Description	Part Number
	1.25 inch port diameter	GE01555X032
	Tungsten Carbide	
	NPS 1 valve	
	0.25 inch port diameter	20C3696X012
	0.375 inch port diameter	20C3697X012
	0.5 inch port diameter	20C3698X012
	0.75 inch port diameter	20C3699X012
	NPS 2 valve	
	0.25 inch port diameter	20C3682X012
	0.375 inch port diameter	20C3683X012
	0.5 inch port diameter	20C3685X012
	0.75 inch port diameter	20C3686X012
	1-inch port diameter	20C3687X012
	1.25 inch port diameter	20C3688X012
3*	Seat Ring	
	S17400 H1150 DbI	
	NPS 1 valve	
	0.25 inch port diameter	GE00982X032
	0.375 inch port diameter	GE00983X032
	0.5 inch port diameter	GE00984X032
	0.75 inch port diameter	GE00985X032
	NPS 2 valve	
	0.25 inch port diameter	GE00986X032
	0.375 inch port diameter	GE00987X032
	0.5 inch port diameter	GE00988X032
	0.75 inch port diameter	GE00989X032
	1-inch port diameter	GE00990X032
	1.25 inch port diameter	GE00991X032
	Tungsten Carbide	
	NPS 1 valve	
	0.25 inch port diameter	GE07347X012
	0.375 inch port diameter	GE07363X012
	0.5 inch port diameter	GE07364X012
	0.75 inch port diameter	GE07365X012
	NPS 2 valve	
	0.25 inch port diameter	GE07389X012
	0.375 inch port diameter	GE07394X012
	0.5 inch port diameter	GE07397X012
	0.75 inch port diameter	GE07398X012
	1-inch port diameter	GE07399X012
	1.25 inch port diameter	GE07406X012
	Groove Pin	GE01163X012
4*	Bonnet	
5	Hammer Nut	
6	Spring Pin	
7	Bonnet O-ring	
8*	Hydrogenated Nitrile	
	-46 to 149°C (-50 to 300°F)	10C3680X012
	FKM, -23 to 204°C (-10 to 400°F)	10C3680X022
9*	Seat Ring Gasket	
	For NPS 1 valve	1B198636042
	For NPS 2 valve	1B198836042
10	Packing Retainer	
11	Belleville Springs, 5 req'd	
12*	Anti-Extrusion Washer, 2 req'd	12B6335X022
13*	Packing Set	12B6667X012
14	Packing Spacer	
15*	Diaphragm	22B3521X012
16	Nameplate	
17	Drive Screw	
18*	Casing O-ring	1F9141X0142
19*	Stem O-ring	1K7561X0072
20*	Bonnet Bushing	17A7112X012
23	Upper Casing Assembly	

\* Recommended spare parts

Key	Description	Part Number	Key	Description	Part Number
25*	Actuator O-ring	1K7561X0072	40	Diaphragm Plate	
26*	Adjusting Stem Bushing (spring-to-open only)	17A4059X012	41	Diaphragm Washer	
27	Spring Case Assembly		42	Hex Nut	
28	Lower Spring Seat		43	Lockwasher	
29	Upper Spring Seat		44	Adjustment Screw Nut	
30	Spring		45	Cap Screw	
	Spring-to-Close, Light Rate	1F176827092	46	Hex Nut	
	Spring-to-Close, Heavy Rate	1E792427082	47*	Valve Stem	
	Spring-to-Open, Light Rate	1F176727032		S20910, Reverse Acting	20C3681X022
	Spring-to-Open, Heavy Rate	1F714327092		S20910, Direct Acting	20C3716X022
31	Adjustment Screw or Stem		48	Upper packing spacer	
32	Travel Indicator		49	Lubricant (lithium grease)	
34	Vent Assembly		51	Drive Screw	
36*	Cotter Pin (spring-to-open only)	1C608035022	53*	Actuator Stem O-ring (spring-to-open only)	1C7821X0182
37	Pipe Plug		54	Lubricant (anti-seize)	
38	Cap Screw		55	Spring Setting Label (not shown)	
39	Lower Casing		56	High Performance Fluorinated Grease	
				Packing Lubricant	

## Appendix A

---

### **Note**

These instructions apply to valves manufactured with serial numbers less than 18679262.

---

## Valve Packing

### **⚠ WARNING**

**Observe the warning at the start of the Maintenance section.**

---

The valve stem packing can only be accessed from within the valve body. If packing maintenance is required, first disassemble per steps 1, 2, and 6 or 7 in the Valve Plug and Seat Ring Disassembly section of this document.

### **Disassembly**

1. Loosen the packing retainer locknut (key 22) with a spanner wrench or with a punch and hammer.
2. Unscrew the packing retainer (key 10) from the bonnet (key 5).
3. Remove the three Belleville springs (key 11), packing spacer (key 14), packing (key 13), and two anti-extrusion rings (key 12) from the bonnet, using a formed wire hook.
4. Clean and inspect the packing box wall to ensure that the packing surfaces are not damaged. If the surface condition is damaged, and cannot be improved by light sanding, replace the bonnet by contacting your Emerson Process Management sales office.
5. Inspect the valve stem for scratches or wear, and valve plug for wear or damage. Replace if necessary.

Figure 6. Fisher D4 Belleville Spring Procedure

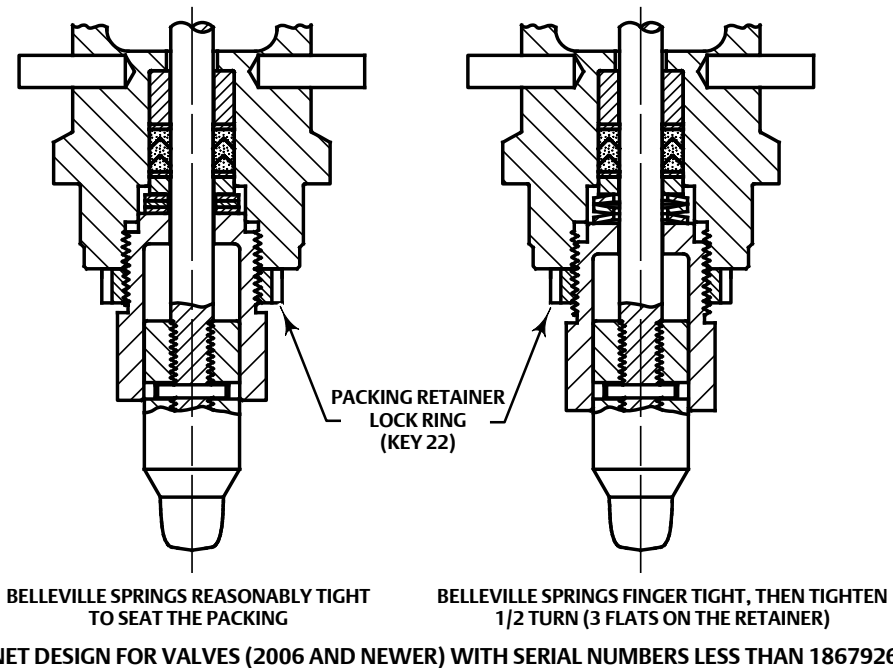
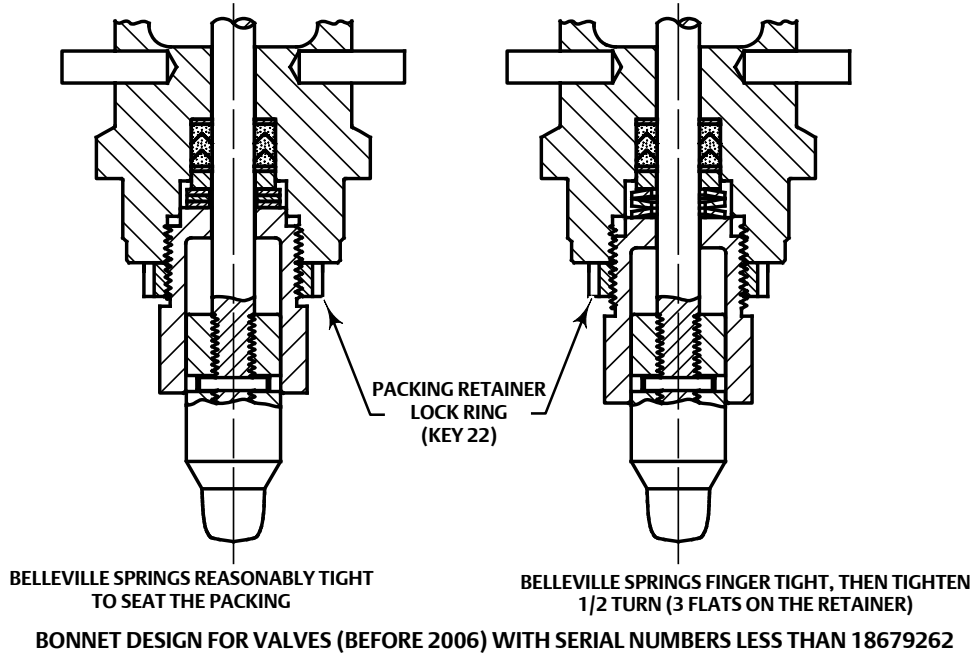

NOTE: RECOMMENDED SPARE PARTS, INCLUDING PACKING KITS, ARE THE SAME FOR BOTH BONNET DESIGNS.  
NOTE: FOR SERIAL NUMBERS GREATER THAN 18679262, SEE THE STANDARD SECTION OF THIS INSTRUCTION MANUAL.

Figure 7. Lubrication Locations on Packing

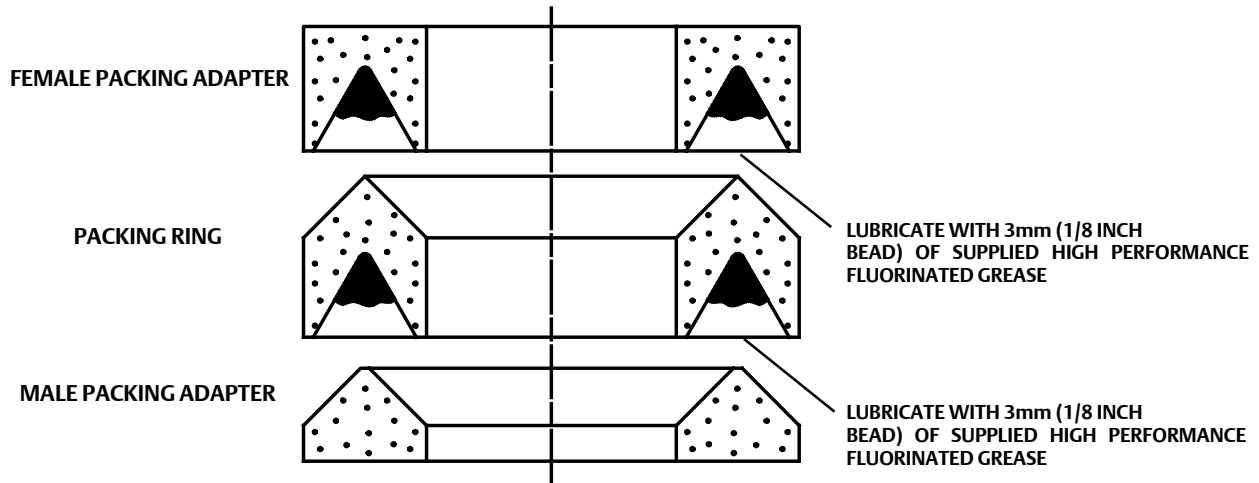

## Assembly

Refer to figures 6 and 7.

1. Install new packing and Belleville springs according to the packing arrangement shown in figure 6.
2. Using a non-marring installation tool, such as a 12-inch length of 1/2 inch PVC pipe, push the first anti-extrusion washer (key 12) fully into the packing box by hand. Then, use the packing spacer (key 14) to fully seat the anti-extrusion washer by firmly tapping the packing spacer against the anti-extrusion washer with a hammer and the PVC pipe.
3. Remove the packing spacer from the packing bore.

## CAUTION

**All D4 packing kits include a single use packet of high performance fluorinated grease. This is the only acceptable D4 packing lubricant.**

### Note

In the following procedure, carefully install each packing ring individually over the valve stem and push completely into the packing box with a non-marring tube. A 12-inch length of 1/2 inch PVC pipe works well for this. It is recommended that the lubricated packing rings be installed individually rather than pushed in as a set.

4. Apply a 3mm (1/8 inch) bead of the supplied high performance fluorinated grease (key 44) around the groove of the female packing adaptor as shown in figure 7 and install over the valve stem (key 16).
5. Apply a 3mm (1/8 inch) bead of the supplied high performance fluorinated grease (key 44) around the groove of the packing ring as shown in figure 7 and install over the valve stem.
6. Install the male packing adaptor, lower anti-extrusion washer (key 10), and lower packing spacer over the valve stem as shown in figure 6.
7. Firmly press all packing parts into the packing bore with a tube.

8. Install the Belleville springs (key 11). The Belleville springs (key 11) should be single stacked with the I.D. of the inner spring contacting the packing spacer (key 14) and the O.D. of the outer spring contacting the packing retainer (key 10). The final Belleville spring should be within the 1.26 inch diameter bore of the bonnet.
9. Adjust the packing retainer by hand until it makes contact with the Belleville springs. Do not tighten by hand, simply install the packing retainer until it makes contact with the Belleville springs. Tighten the packing retainer clockwise precisely 1.16 turns (7 flats on the retainer) to seat the packing. This should fully compress the Belleville springs as detected by an increase in torque between 6 and 7 flats.
10. Loosen the packing retainer completely. Adjust the packing retainer by hand until it makes contact with the Belleville springs. Do not tighten by hand, simply install the packing retainer until it makes contact with the Belleville springs. Tighten the packing retainer clockwise precisely 1/2 turn (3 flats on the retainer).
11. Lock the packing retainer (key 10) solidly in place by tightening the packing retainer locknut (key 22) using a spanner wrench or a hammer and punch or chisel.



**Neither Emerson, Emerson Process Management, nor any of their affiliated entities assumes responsibility for the selection, use or maintenance of any product. Responsibility for proper selection, use, and maintenance of any product remains solely with the purchaser and end user.**

Fisher is a mark owned by one of the companies in the Emerson Process Management business unit of Emerson Electric Co. Emerson Process Management, Emerson, and the Emerson logo are trademarks and service marks of Emerson Electric Co. All other marks are the property of their respective owners.

The contents of this publication are presented for informational purposes only, and while every effort has been made to ensure their accuracy, they are not to be construed as warranties or guarantees, express or implied, regarding the products or services described herein or their use or applicability. All sales are governed by our terms and conditions, which are available upon request. We reserve the right to modify or improve the designs or specifications of such products at any time without notice.

**Emerson Process Management**

Marshalltown, Iowa 50158 USA

Sorocaba, 18087 Brazil

Chatham, Kent ME4 4QZ UK

Dubai, United Arab Emirates

Singapore 128461 Singapore

[www.Fisher.com](http://www.Fisher.com)