

# Fisher® EHD and EHT NPS 8 through 14 Sliding-Stem Control Valves

## Contents

Introduction .....	1
Scope of Manual .....	1
Description .....	2
Specifications .....	2
Educational Services .....	3
Installation .....	3
Principle of Operation .....	5
Maintenance .....	5
Packing Lubrication .....	6
Packing Maintenance .....	7
Replacing Packing .....	7
Trim Removal .....	12
EHD, EHT Valve Plug Maintenance .....	12
Lapping Seats .....	13
Trim Replacement .....	14
Retrofit: Installing Bore Seal Trim .....	17
Replacement of Installed Bore Seal Trim .....	19
Trim Removal (Bore Seal Constructions) ....	19
Lapping Metal Seats (Bore Seal Constructions) .....	20
Remachining Metal Seats (Bore Seal Constructions) .....	20
Trim Replacement (Bore Seal Constructions) .....	20
Actuator Mounting .....	22
Parts Ordering .....	22
Parts Kits .....	23
Parts List .....	25
Bonnet Assembly .....	25
Valve Assembly .....	27

Figure 1. Fisher EH Series Control Valve with 667 Actuator



## Introduction

### Scope of Manual

This instruction manual includes installation, maintenance, and parts ordering information for NPS 8 through 14 Fisher EHD and EHT sliding-stem globe-style control valves. Refer to separate manuals for instructions covering the actuator, positioner, and accessories.

Do not install, operate, or maintain an EH valve without being fully trained and qualified in valve, actuator, and accessory installation, operation, and maintenance. **To avoid personal injury or property damage, it is important to carefully read, understand, and follow all the contents of this manual, including all safety cautions and warnings.** If you have any questions about these instructions, contact your Emerson Process Management sales office before proceeding.



Table 1. Specifications

<p><b>End Connection Styles<sup>(1)</sup></b></p> <p><b>Buttwelding:</b> All available ASME B16.25 schedules that are compatible with ASME B16.34 pressure/temperature ratings</p> <p><b>Flanged Ends:</b> CL1500 or 2500 ■ raised-face (RF) or ■ ring-type joint (RTJ) flanges per ASME B16.5</p> <p><b>Shutoff Classifications</b></p> <p>See table 2</p> <p><b>Bore seal trim:</b> High-temperature, Class V. See table 3</p> <p><b>Flow Characteristic</b></p> <p><b>Standard Cages:</b> ■ Linear, ■ equal percentage, or ■ modified equal percentage<sup>(2)</sup></p>	<p><b>Whisper Trim™ III Cages:</b> ■ Linear or ■ modified characteristics available upon request</p> <p><b>Flow Direction</b></p> <p>Normally flow down (in through the cage windows and out through the seat ring) for all cage styles except for applications using either a Whisper Trim III cage or a diverter cone plug, both of which are flow up only</p> <p><b>Additional Specifications</b></p> <p>For specifications such as materials, valve plug travels, and port, yoke boss, and stem diameters, see the Parts List section</p> <p><b>Approximate Weights</b></p> <p>See table 4</p>
---	--

1. The pressure or temperature limits in this manual and any applicable standard limitations should not be exceeded.

2. Valves using an equal percentage cage may be travelled an additional 13 mm (0.5 inch) if desired to obtain additional capacity; flow characteristic becomes modified equal percentage.

Table 2. Shutoff Classifications<sup>(1)</sup>

Valve Design	ANSI/FCI LEAKAGE CLASS
EHD	III—Standard
	IV—Optional
EHT	IV—Standard
	V—Optional
EHT w/ PEEK <sup>(2)</sup> Anti-Extrusion Rings	V to 316°C (600°F)

1. Per ANSI/FCI 70-2 and IEC 60534-4  
2. Poly Ether Ether Ketone

## Description

The EHD and EHT valves, shown in figure 1, are large, sliding-stem, high-pressure, globe-style valves. These valves have metal seats, cage guiding, and push-down-to-close valve plug action.

The EHD and EHT valves feature balanced valve plugs. To provide a seal between the valve plug and cage, the EHD valve plug has piston rings; the EHT valve plug has a pressure-assisted seal ring.

Bore seal trim is available for EHD valves, CL1500, NPS 8 and 10 and CL2500, NPS 8, 10, 12, and 14.

With Bore seal trim, a balanced valve can achieve high-temperature, Class V shutoff. Because the Bore seal plug seal is formed from metal (N07718 nickel alloy) rather than an elastomer, a valve equipped with the Bore seal trim can be applied in processes with a fluid temperature of up to 593°C (1100°F), provided other material limits are not exceeded.

## Specifications

Specifications for the EHD and EHT valves are shown in table 1.

## Educational Services

For information on available courses for the Fisher EH NPS 8 through 14 valve, as well as a variety of other products, contact:

Emerson Process Management  
 Educational Services - Registration  
 Phone: 1-641-754-3771 or 1-800-338-8158  
 E-mail: education@emerson.com  
<http://www.emersonprocess.com/education>

**Table 3. Additional Shutoff Classification**

Valve Design (PRESSURE RATING)	Valve Size, NPS	Port Diameter, Inches	Cage Style	ANSI/FCI Leakage Class
EHD (CL1500)	8 10	7	Equal Percentage Modified Equal Percentage Linear (std. cage) Linear (Whisper III, A1, B3, C3)	V with optional Bore seal trim
EHD (CL2500)	8 10	5.375	Equal Percentage, Modified Equal Percentage, Linear (std. cage), Linear (Whisper III, A1, B3, C3, D3)	V with optional Bore seal trim
	12 14	7	Equal Percentage, Modified Equal Percentage, Linear (std. cage), Linear (Whisper III, A1, B3, C3, D3)	V with optional Bore seal trim

**Table 4. Approximate Weights (Valve Body and Bonnet Assemblies)**

VALVE SIZE, NPS	WEIGHTS							
	CL1500				CL2500			
	Buttwelding Ends		Flanged		Buttwelding Ends		Flanged	
	Kilograms	Pounds	Kilograms	Pounds	Kilograms	Pounds	Kilograms	Pounds
8	1400	3100	1700	3700	1900	4100	2200	4700
10	1500	3300	1900	4100	2000	4400	---	---
12	3400	7300	3900	8600	3400	7600	---	---
14	3400	7300	---	---	3400	7600	---	---

## Installation

### **⚠ WARNING**

Always wear protective gloves, clothing, and eyewear when performing any installation operations to avoid personal injury.

To avoid personal injury or property damage resulting from the sudden release of pressure, do not install the valve assembly where service conditions could exceed the limits given in this manual or on the appropriate nameplates. Use pressure-relieving devices as required by government or accepted industry codes and good engineering practices.

Check with your process or safety engineer for any additional measures that must be taken to protect against process media.

If installing into an existing application, also refer to the WARNING at the beginning of the Maintenance section in this instruction manual.

**CAUTION**

The valve configuration and construction materials were selected to meet particular pressure, temperature, pressure drop, and controlled fluid conditions. Because some body/trim material combinations are limited in their pressure drop and temperature range capabilities, do not apply any other conditions to the valve without first contacting your Emerson Process Management sales office.

If hoisting the valve, use a nylon sling to protect the painted surfaces. Carefully position the sling to prevent damage to the actuator tubing or any accessories. Also, take precautions to prevent personnel from being injured in case the hoist or rigging slips unexpectedly. Refer to table 4 for valve assembly weights and the appropriate actuator instruction manual for actuator assembly weights. Be sure to use adequately sized hoists and chains or slings to handle the valve and actuator assembly.

1. Before installing the valve, inspect it to ensure that the valve body cavity is free of foreign material.
2. Clean out all pipelines to remove scale, welding slag, and other foreign materials before installing the valve.

**Note**

If installing a valve with small internal flow passages, such as with Whisper Trim III or Cavitrol™ III cages, consider installing an upstream strainer to prevent the lodging of particles in these passages. This is especially important if the pipeline cannot be thoroughly cleaned or if the flowing medium is not clean.

3. Install the control valve with the valve body in a horizontal pipeline and the actuator vertical above the valve. Other orientations may result in shortened trim life and difficulty with field maintenance. Flow through the valve body must be in the direction indicated by the flow arrow (key 15, figure 12 or 14) on the valve body.

**CAUTION**

Depending on valve body materials used, post-weld heat treating might be needed. Post-weld heat treatment can damage internal elastomeric, plastic, and metal parts. Shrink-fit pieces and threaded connections might also loosen. In general, if post-weld heat treating is needed, remove all trim parts. Contact your Emerson Process Management sales office for additional information.

4. Use accepted piping and welding practices when installing the valve in the line. For flanged valve bodies, use suitable gaskets between the valve body flanges and pipeline flanges.
5. Install a three-valve bypass around the control valve if continuous operation is required during maintenance.
6. If the actuator and valve are shipped separately, see the Actuator Mounting procedure.

**⚠ WARNING**

Personal injury could result from packing leakage. Valve packing was tightened prior to shipment; however some readjustment will be required to meet specific service conditions.

7. If the valve was shipped without packing installed in the packing box, install the packing prior to putting the valve into service. Refer to instructions given in the Packing Maintenance section of this manual.

## Principle of Operation

Key numbers referenced in this section are shown in figure 12 for the EHD valve and in figure 14 for the EHT valve.

EHD and EHT valves are balanced designs. When they are opening or closing, pressure registers on top of the valve plug (key 3) through the registration holes in the plug. The force of the pressure on top of the plug balances the force of the pressure on the bottom of the plug to reduce the actuator force required.

## Maintenance

Valve parts are subject to normal wear and must be inspected and replaced as necessary. Inspection and maintenance frequency depends on the severity of service conditions. This section includes instructions for packing lubrication and maintenance, trim maintenance, and lapping of metal seats. All maintenance operations can be performed with the valve in the line.

### **⚠ WARNING**

**Avoid personal injury from sudden release of process pressure. Before performing any maintenance operations:**

- Do not remove the actuator from the valve while the valve is still pressurized.
- Always wear protective gloves, clothing, and eyewear when performing any maintenance operations to avoid personal injury.
- Disconnect any operating lines providing air pressure, electric power, or a control signal to the actuator. Be sure the actuator cannot suddenly open or close the valve.
- Use bypass valves or completely shut off the process to isolate the valve from process pressure. Relieve process pressure on both sides of the valve. Drain the process media from both sides of the valve.
- Vent the power actuator loading pressure and relieve any actuator spring precompression.
- Use lock-out procedures to be sure that the above measures stay in effect while you work on the equipment.
- The valve packing box may contain process fluids that are pressurized, *even when the valve has been removed from the pipeline*. Process fluids may spray out under pressure when removing the packing hardware or packing rings, or when loosening the packing box pipe plug.
- Check with your process or safety engineer for any additional measures that must be taken to protect against process media.

### **⚠ WARNING**

**Refer to table 4 for valve assembly weights and the appropriate actuator instruction manual for actuator assembly weights. Due to the size and weight of the valve and actuator assembly, be sure adequately sized hoists and chains or slings are used to handle it. Also, take proper precautions to prevent personnel from being injured if the hoist or rigging slips unexpectedly.**

### **Note**

Whenever a gasket seal is disturbed by removing or shifting gasketed parts, install a new gasket upon reassembly. This is necessary to ensure a good gasket seal.

8. After all maintenance is complete, refer to the Trim Replacement procedure to assemble the valve body.

#### Note

If the valve has ENVIRO-SEAL™ live-loaded packing installed, see the Fisher instruction manual titled ENVIRO-SEAL Packing System for Sliding-Stem Valves (D101642X012) for packing instructions.

If the valve has HIGH-SEAL live-loaded packing installed, see the Fisher instruction manual titled HIGH-SEAL Live-Loaded Packing System (D101453X012) for instructions.

Figure 2. Lubricator and Lubricator/Isolating Valve

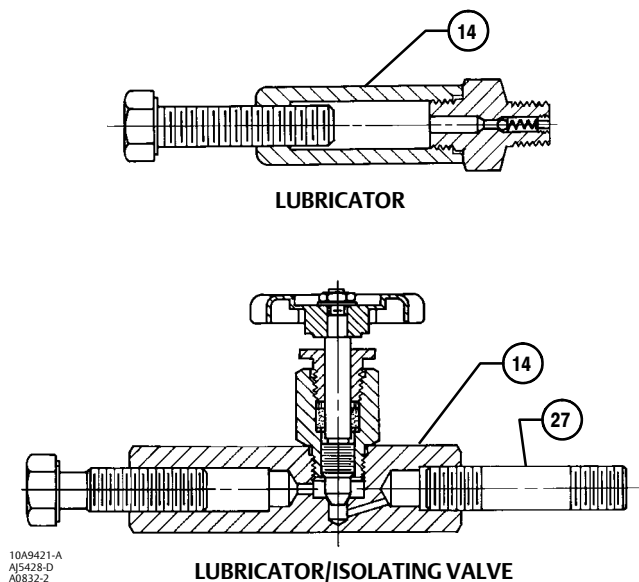

## Packing Lubrication

### ⚠ WARNING

To avoid personal injury or property damage resulting from fire or explosion, do not lubricate packing used in oxygen service or in processes with temperatures over 260°C (500°F).

### CAUTION

Do not lubricate graphite packing. Graphite packing is self-lubricated. Additional lubrication may result in slip-stick movement of the valve.

#### Note

ENVIRO-SEAL or HIGH-SEAL packing does not require lubrication.

A lubricator or lubricator/isolating valve (figure 2) is recommended for PTFE-impregnated composition packing. The lubricator or lubricator/isolating valve is installed in place of the pipe plug in the bonnet. Use a good quality silicon-base lubricant. Do not lubricate packing used in oxygen service or in processes with temperatures over 260°C (500°F). To operate the lubricator, turn the cap screw clockwise to force lubricant into the packing box. The lubricator/isolating valve operates the same way except open the isolating valve before turning the cap screw and then close the isolating valve after lubrication is completed.

## Packing Maintenance

### **⚠ WARNING**

**Personal injury could result from packing leakage. Valve packing was tightened before shipment; however, the packing might require readjustment to meet specific service conditions.**

Valves with ENVIRO-SEAL live-loaded packing or HIGH-SEAL live-loaded packing installed probably will not require this initial re-adjustment. See the Fisher instruction manuals titled ENVIRO-SEAL Packing System for Sliding-Stem Valves (D101642X012) or HIGH-SEAL Live-Loaded Packing System (D101453X012) (as appropriate) for packing instructions. To convert an existing packing arrangement to ENVIRO-SEAL packing, refer to the retrofit kits listed in the parts kit sub-section near the end of this manual. Figure 10 shows typical ENVIRO-SEAL packing systems.

For spring-loaded PTFE V-ring packing (figure 4), the spring maintains a sealing force on the packing. If leakage is noted around the packing follower (key 13, figure 11), check to be sure the shoulder on the packing follower is touching the bonnet (key 1, figure 11). If the shoulder is not touching the bonnet, tighten the packing flange nuts (key 5, figure 11) until the shoulder on the packing follower is against the bonnet. If the packing leakage is still excessive, replace the packing by following the Replacing Packing procedure.

If packing leakage is undesirable with other than spring-loaded PTFE V-ring packing, first try to limit the leakage and establish a stem seal by tightening the packing flange nuts (key 5, figure 11) to at least the minimum recommended torque in table 5. However, do not exceed the maximum recommended torque in table 5 or excessive friction may result.

**Table 5. Recommended Packing Flange Nut Torques**

STEM DIAMETER		VALVE RATING	N•m		Lbf•ft	
mm	Inches		Min	Max	Min	Max
31.8	1-1/4	CL1500	68	102	50	75
		CL2500	81	122	60	90
50.8	2	CL1500	98	146	72	108
		CL2500	115	170	85	125

If the packing is relatively new and tight on the stem, and if tightening the packing flange nuts does not stop the leakage, the valve stem may be worn or nicked so that a seal cannot be made. The surface finish of a new stem is critical for making a good packing seal. If the leakage comes from the outside diameter of the packing, the leakage may be caused by nicks or scratches around the packing box wall. While replacing the packing according to the Replacing Packing procedure, inspect the stem and packing box wall for nicks or scratches.

## Replacing Packing

### **⚠ WARNING**

**Refer to the WARNING at the beginning of the Maintenance section in this instruction manual.**

Key numbers referred to in this procedure are shown in figure 11 unless otherwise indicated.

1. Remove the stem connector cap screws shown in figure 3, and separate the two halves of the stem connector. Then exhaust all actuator pressure, if any was applied, and disconnect the actuator supply and any leakoff piping.
2. Remove the hex nuts (key 26) and remove the actuator from the bonnet (key 1). Loosen the packing flange nuts (key 5) so that the packing (key 6, or 7 and 9, figure 4) is not tight on the valve plug stem (key 4, figure 12 or 14). Remove any travel indicator disk and stem locknuts from the valve plug stem threads.

## **⚠ WARNING**

**Do not remove a stuck bonnet by pulling on it with equipment that can stretch or store energy in any other manner. The sudden release of stored energy can cause uncontrolled movement of the bonnet. To avoid personal injury or property damage caused by uncontrolled movement of the bonnet, loosen the bonnet by following the instructions in the next step.**

Figure 3. Actuator Mounting

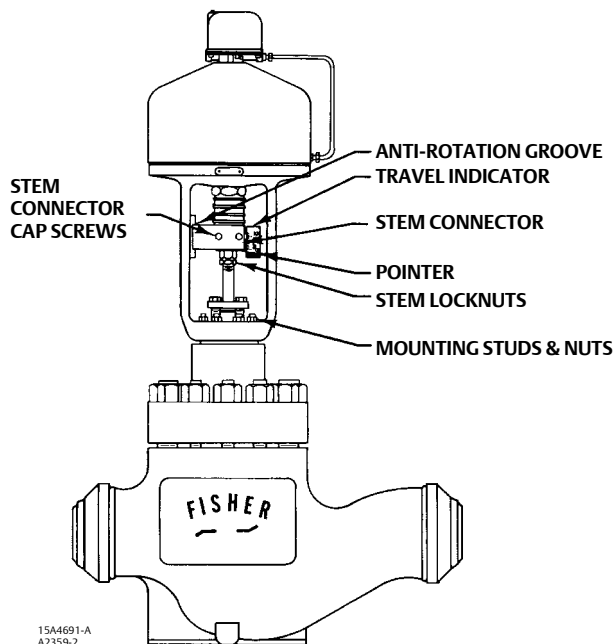

### Note

The following step also provides additional assurance that the valve fluid pressure has been relieved.

3. Hex nuts (key 14, figures 12 and 14) attach the bonnet to the valve body. Loosen these nuts approximately 3 mm (1/8 inch). Then loosen the body-to-bonnet gasketed joint by either rocking the bonnet or prying between the bonnet and valve body. Work the prying tool around the bonnet until the bonnet loosens. If no fluid leaks from the joint, proceed with the bonnet removal in step 5.

## **⚠ WARNING**

**If the cage sticks to the bonnet, proceed carefully with bonnet removal until the cage windows are accessible. Do not extend hands or arms through the windows at this point as a sudden separation of bonnet and cage will cause personal**



**injury. Use a stick or other device to thread a rope or sling through the windows. Use this rigging to secure the cage to the bonnet or hoist to prevent damage or injury should the cage suddenly separate from the bonnet.**

**CAUTION**

**When lifting the bonnet (key 1), be sure that the valve plug and stem assembly (keys 3 and 4, figure 12 or 14) remains on the seat ring (key 6, figure 12 or 14). This avoids damage to the seating surfaces as a result of the assembly dropping from the bonnet after being lifted part way out. The parts are also easier to handle separately.**

- Remove the hex nuts (key 14, figure 12 or 14) and washers (key 29 and 33, figure 12, 13, or 14). Carefully lift the bonnet off the valve plug stem. If the valve plug assembly starts to lift with the bonnet, use a brass or similar hammer to tap the end of the stem and tap it back down. Set the bonnet on a protective surface to prevent damage to the bonnet gasket surface.

**CAUTION**

**Use care to avoid damaging gasket sealing surfaces.**

**EHD piston rings (key 8) are brittle and in two halves. Use care to avoid damage to the piston rings caused by dropping or rough handling.**

- Lift the plug assembly (keys 3 and 4, figure 12 or 14) out of the valve body.
- To remove the cage (key 2, figure 12 or 14), if it remained in the valve body, install eyebolts or similar devices into the 1/2 inch 13-UNC tapped holes in the top of the cage. Using the eyebolts, carefully lift the cage out of the valve body. Remove the top and bottom cage gaskets (key 11, figure 12 or 14). Carefully remove any residual silver or tin from the gasket surfaces.
- Cover the opening in the valve body to protect the gasket surface and to prevent foreign material from getting into the valve body cavity.

**Table 6. Body-to-Bonnet Bolting Torques**

VALVE SIZE NPS	VALVE RATING	B7, B16, BD, 660 STUDS		B8, B8M STUDS	
		N•m	lbf•ft	N•m	lbf•ft
8, 10	CL1500	2710	2000	2035	1500
	CL2500	4070	3000	3050	2250
12, 14	CL1500	8130	6000	6100	4500
	CL2500	5830	4300	4370	3225

- Remove the packing flange nuts, packing flange, upper wiper and packing follower. Carefully push out all the remaining packing parts from the valve side of the bonnet using a rounded rod or other tool that will not scratch the packing box wall. Clean the packing box and these metal packing parts shown in the figure 4 arrangements: packing box ring, spring, lantern ring, washer if used, and packing follower (keys 11, 8, 10, and 13).
- Inspect the valve plug stem threads for any sharp edges that might cut the packing. Use a whetstone or emery cloth to smooth the threads if necessary.
- Remove the protective covering from the valve body cavity, and install the cage using new cage gaskets (key 11, figure 12 or 14).
- Install the plug and stem assembly. Be sure the seal ring or piston rings are installed correctly as described under Trim Replacement.

Figure 4. Packing Arrangements

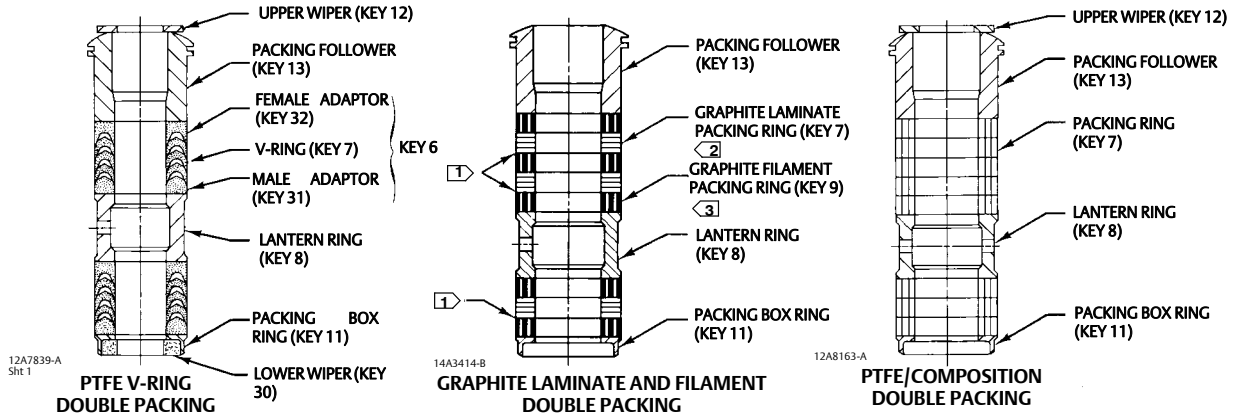
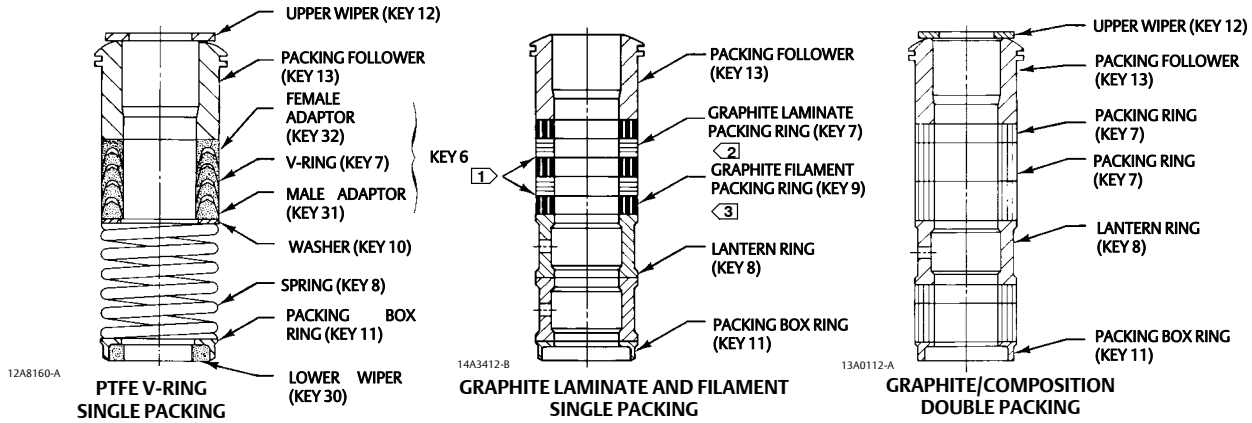

PACKING ARRANGEMENTS FOR 31.8 mm (1-1/4 INCH) VALVE STEMS

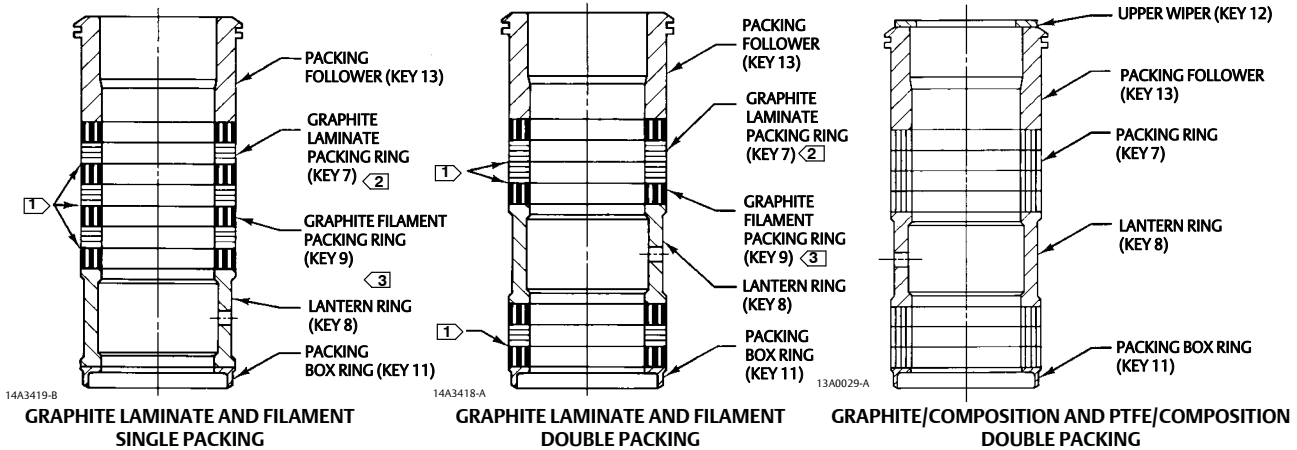

PACKING ARRANGEMENTS FOR 50.8 mm (2-INCH) VALVE STEMS

NOTES:  
 ① 0.102 mm (0.004 INCH) THICK SACRIFICIAL ZINC WASHERS. USE ONLY ONE BELOW EACH GRAPHITE LAMINATE RING.

② HAS THE APPEARANCE OF FLAT WASHERS PRESSED TOGETHER.  
 ③ HAS THE APPEARANCE OF A WOVEN OR BRAIDED RING.

C0634-1

12. Slide the bonnet over the stem and onto the bonnet studs (key 13, figure 12 or 14).

---

**Note**

Proper performance of the bolting procedures in step 13 compresses the cage gaskets (key 11, figure 12 or 14) enough to seal the body-to-bonnet joint.

The prelubricated hex nuts (key 14, figure 12 or 14) referred to in step 13 can be identified by a black film coating on the nut threads.

The proper bolting procedures in step 13 include, but are not limited to, ensuring that the bonnet stud threads are clean, Belleville washers (if present) are installed in the correct orientation, and that the hex nuts are evenly tightened to the specified torque values.

---

**CAUTION**

**Failure to comply with good bonnet-to-body bolting practices and the torque values shown in table 6 may result in cage crushing, cage diameter reduction, and/or bonnet deformation. Do not use cheater bars or slug wrenches for this procedure.**

**Hot torquing is not recommended; it may result in damage to valve components.**

---

**Note**

Stud(s) and nut(s) should be installed such that the manufacturer's trademark and material grade marking is visible, allowing easy comparison to the materials selected and documented in the Emerson/Fisher serial card provided with this product.

---

**▲ WARNING**

**Personal injury or damage to equipment could occur if improper stud and nut materials or parts are used. Do not operate or assemble this product with stud(s) and nut(s) that are not approved by Emerson/Fisher engineering and/or listed on the serial card provided with this product. Use of unapproved materials and parts could lead to stresses exceeding the design or code limits intended for this particular service. Install studs with the material grade and manufacturer's identification mark visible. Contact your Emerson Process Management representative immediately if a discrepancy between actual parts and approved parts is suspected.**

---

13. Lubricate the stud threads and the faces of the hex nuts (key 14, figure 12 or 14) with anti-seize lubricant (not necessary if new factory prelubricated hex nuts are used). Replace the flat washers (key 29, figure 12 or 14) and Belleville washers (key 33, figure 13), if included with the valve body assembly. Belleville washers must be installed so that the concave side is facing towards the valve body or flat washer. Replace the hex nuts and torque the nuts in a crisscross pattern to no more than 1/4 of the nominal torque value specified in table 6. When all nuts are tightened to that torque value, increase the torque by 1/4 of the specified nominal torque and repeat the crisscross pattern. Repeat this procedure until all nuts are tightened to the specified nominal value. Apply the final torque value again and, if any nut still turns, tighten every nut again.
14. Install new packing and the metal packing box parts according to the appropriate arrangement in figure 4. Slip a smooth-edged pipe over the valve stem, and gently tamp each soft packing part into the packing box.
15. Slide the packing follower, wiper, and packing flange into position. Lubricate the packing flange studs (key 4) and the faces of the packing flange nuts (key 5) and then install the packing flange nuts.

**For spring-loaded PTFE V-ring packing:** Tighten the packing flange nuts until the shoulder on the packing follower (key 13) contacts the bonnet (key 1).

**For other kinds of packing, except ENVIRO-SEAL and HIGH-SEAL:** Tighten the packing flange nuts to the maximum recommended torque shown in table 5. Then, loosen the packing flange nuts and retighten them to the recommended minimum torque in table 5.

**For ENVIRO-SEAL and HIGH-SEAL packing:** See the Fisher instruction manuals titled ENVIRO-SEAL Packing System for Sliding-Stem Valves (D101642X012) or HIGH-SEAL Live-Loaded Packing System (D101453X012) (as appropriate) for packing instructions.

**Table 7. Seat Ring and Seat Ring Cap Screw Lubricants and Recommended Torque for Seat Ring Cap Screws**

LUBRICANT	VALVE SIZE, NPS	VALVE RATING	RECOMMENDED TORQUE			
			Spiral Wound Gasket Construction		O-Ring Construction or Constructions for Sour Gas Service	
			N•m	lbf•ft	N•m	lbf•ft
Lithium Grease or Anti-Seize Lubricant	8, 10	CL1500	61	45	41	30
		CL2500	95	70	61	45
	12, 14	CL1500	95	70	61	45
		CL2500	95	70	61	45
Dry Film Lubricant	8, 10	CL1500	47	35	34	25
		CL2500	75	55	47	35
	12, 14	CL1500	75	55	47	35
		CL2500	75	55	47	35

16. Mount the actuator on the valve body assembly, and reconnect the actuator and valve plug stem according to the Actuator Mounting procedure. After the control valve is returned to service, retighten the hex nuts (key 14, figure 12 or 14) to the torque recommended in table 6.

## Trim Removal

### **▲ WARNING**

Refer to the **WARNING** at the beginning of the Maintenance section in this instruction manual.

For Bore seal construction, see the appropriate Bore seal sections in this instruction manual.

Key numbers referenced in this procedure are shown in figure 12 for the EHD valve and figure 14 for the EHT valve except where indicated.

1. Remove the actuator and bonnet by following steps 1 through 9 of the Replacing Packing procedure.
2. To remove the seat ring (key 6), remove the cap screws (key 7). Install eyebolts or similar devices in the 5/8 inch 11-UNC tapped holes (9/16 inch 12-UNC for an NPS 8 or 10 CL1500 valve). Use the eyebolts to carefully lift the seat ring out of the valve body. If the seat ring is to be reused, exercise care to protect the gasket surfaces on the bottom of the seat ring.
3. Remove the spiral wound seat ring gasket or O-ring (key 12).
4. Refer to the following appropriate valve plug maintenance procedure or to the Lapping Seats procedure.

## EHD and EHT Valve Plug Maintenance

Key numbers used in this procedure are shown in figure 12 for the EHD valve and in figure 14 for the EHT valve.

1. With the valve plug (key 3) removed per the Trim Removal procedure, proceed as appropriate:

**For the EHD valve**, the piston rings (key 8) are each in two sections; remove the sections from the grooves in the valve plug.

**For all EHT valves**, work the retaining ring (key 10) off the valve plug with a screwdriver. Carefully slide the backup ring and seal ring (keys 9 and 8) off the valve plug. Additionally, for the EHT valve with Whisper Trim Level D cage, remove the two sections of the piston ring (key 30, figure 14).

2. To replace the valve plug stem (key 4), drive out the pin (key 5) and unscrew the stem from the valve plug (key 3).

## CAUTION

**Never reuse an old stem with a new valve plug. Using an old stem with a new plug requires drilling a new pin hole in the stem. This weakens the stem and may cause the stem to fail in service. If a new valve plug is required, always order a valve plug, stem, and pin as an assembly. Specify the correct part number of each of the three parts but state that the parts are being ordered as an assembly.**

**A used valve plug may be reused with a new stem.**

3. Thread the new stem into the valve plug until the stem wedges tightly at the end of the thread. Using the valve plug pin hole as a guide, drill the pin hole through the stem. Use a 1/4 inch drill for 31.8 mm (1-1/4 inch) stems and a 3/8 inch drill for 50.8 mm (2-inch) stems.
4. Drive in the pin to lock the assembly.
5. If seat lapping is necessary, complete the Lapping Seats procedure before installing the EHD piston rings or the EHT seal ring. Piston ring and seal ring installation instructions and valve body-to-bonnet reassembly instructions are presented in the Trim Replacement procedure.

## Lapping Seats

Key numbers referenced in this procedure are shown in figure 12 for the EHD valve and in figure 14 for the EHT valve.

A certain amount of leakage should be expected with metal-to-metal seating in any valve. If the leakage becomes excessive, however, the condition of the seating surfaces of the valve plug (key 3) and seat ring (key 6) can be improved by lapping. (Deep nicks should be machined out rather than ground out.) Use a good quality lapping compound with a mixture that contains 280 to 600 grit. Apply the compound to the bottom of the valve plug.

Use the following procedure to lap the seating surfaces.

1. For all designs, install the seat ring gasket or O-ring (key 12), seat ring (key 6), seat ring cap screws (key 7), lower cage gasket (key 12), cage (key 2), and upper cage gasket (key 12) into the valve body per the instructions in the Trim Replacement procedure.
2. Install the assembled valve plug and stem (keys 3 and 4)--without piston rings or seal ring (key 8)-- into the cage.
3. For all seating surfaces, install the bonnet (key 1, figure 11) over the valve stem and secure the bonnet with four of the hex nuts (key 14).
4. Attach a handle, such as a piece of strap iron secured by stem locknuts, to the valve plug stem. Rotate the handle alternately in each direction to lap the seats.

## Note

In order to preserve the effects of lapping, do not change either the position of the seat ring in the valve body cavity or the position of the cage on the seat ring after lapping the seating surfaces. If possible, clean the parts without disturbing their positions. If the parts must be removed for cleaning, return them to the original positions.

5. After lapping, again disassemble as necessary, clean the seating surfaces, reassemble, and test for shutoff. Repeat the lapping procedure if necessary.

## Trim Replacement

After all trim maintenance has been completed, reassemble the valve by following the numbered steps below. Be certain that all gasketed surfaces are clean. Key numbers referenced in this procedure are shown in figure 12 for the EHD valve and in figure 14 for the EHT valve.

### CAUTION

**Thoroughly clean the seat ring (key 6), the seat ring cap screws (key 7), and the cap screw threads in the valve body with a good-quality degreaser. Unless the valve is to be used for oxygen service, thoroughly lubricate the cap screw threads and the underside of the cap screw heads with one of the lubricants (or equivalent) shown in table 7.**

**Failure to lubricate as described may cause galling and improper seat ring gasket or O-ring (key 12) loading which may result in leakage.**

### ⚠ WARNING

**If the control valve is to be used for oxygen service, use the lubrication procedure above, but substitute a lubricant that has been approved for oxygen service. Use of unapproved lubricants creates a fire or explosion hazard.**

1. Install either the seat ring gasket or the O-ring (key 12). Place the O-ring in the O-ring groove in the seat ring before installing the seat ring in the valve body. Install the seat ring (key 6) and secure it with the seat ring cap screws (key 7). Torque the hex socket head cap screws in a criss-cross pattern with no more than 20 N•m (15 lbf•ft) of torque. When all are tightened to 20 N•m (15 lbf•ft), increase the torque 20 N•m (15 lbf•ft) without exceeding the torque value specified in table 7, and repeat the crisscross pattern. Repeat until all cap screws are tightened to the torque value specified in table 7. Repeat the final torque and if any cap screw still turns, tighten every cap screw again.
2. Install one of the cage gaskets (key 11) between the valve body and cage (key 2), and install the cage.
3. If the cage used has multiple sizes of windows, attempt to orient the largest window toward the valve body web (a shelf-like projection of the casting into the flow cavity). As an alternate reference, orient the largest window toward the process outlet for a flow-down and toward the process inlet for a flow-up valve.
4. Inspect the valve plug stem threads for any sharp edges that might cut the packing. Use a whetstone or emery cloth to smooth the threads if necessary.
5. To install the piston rings or seal ring (key 8), proceed as appropriate:

**For an EHD valve**, if installing a new piston ring, the replacement piston ring will arrive in one piece. Use a vise with smooth or taped jaws to break this replacement piston ring into halves. Place the new ring in the vise so that the jaws compress the ring into an oval. Slowly compress the ring until the ring snaps on both sides. If one side snaps first, do not try to tear or cut the other side. Instead, keep compressing until the other side snaps.

Remove any protective tape or covering from the valve plug and stem assembly, and set it on a protective surface. Then place the piston ring in the piston ring groove with the fractured ends matched.

**For an EHT valve**, install the seal ring (key 8) onto the valve plug (key 3). Install the ring with the open side facing the seat ring end of the valve plug for a flow-down application (view B of figure 14) or with the open side facing the valve stem end of the valve plug for a flow-up application. Slide the backup ring (key 9) onto the valve plug. Secure with the retaining ring (key 10). For an EHT valve with a Whisper Trim Level D cage, install the piston ring (key 30, figure 14) using the procedure given in the EHD instructions immediately preceding this paragraph.

6. Install the valve plug into the cage.
7. Install the other cage gasket (key 11) between the cage and the bonnet.

## CAUTION

Failure to comply with good bonnet-to-body bolting practices and the torque values shown in table 6 may result in cage crushing, cage diameter reduction, and/or bonnet deformation. Cheater bars or slug wrenches should not be used for this procedure.

Hot torquing is not recommended; it may result in damage to valve components.

## Note

Stud(s) and nut(s) should be installed such that the manufacturer's trademark and material grade marking is visible, allowing easy comparison to the materials selected and documented in the Emerson/Fisher serial card provided with this product.

## ⚠ WARNING

Personal injury or damage to equipment could occur if improper stud and nut materials or parts are used. Do not operate or assemble this product with stud(s) and nut(s) that are not approved by Emerson/Fisher engineering and/or listed on the serial card provided with this product. Use of unapproved materials and parts could lead to stresses exceeding the design or code limits intended for this particular service. Install studs with the material grade and manufacturer's identification mark visible. Contact your Emerson Process Management representative immediately if a discrepancy between actual parts and approved parts is suspected.

8. Install the bonnet over the valve stem and onto the valve body. Lubricate the threads of the studs (key 13) and the faces of the hex nuts (key 14) with anti-seize lubricant (key 24). Secure the bonnet with hex nuts (key 14) and washers (key 29). Torque the nuts in a crisscross pattern to no more than 1/4 of the nominal torque value specified in table 6. When all nuts are tightened to that torque value, increase the torque by 1/4 of the specified torque value and repeat the crisscross pattern. Repeat this procedure until all nuts are tightened to the specified nominal value. Repeat the final torque value and if any nut still turns, tighten every nut again.
9. Install new packing and the metal packing box parts according to the appropriate arrangement in figure 4. Slip a smooth-edged pipe over the valve stem, and gently tamp each soft packing part into the packing box.
10. Slide the packing follower, wiper, and packing flange into position. Lubricate the packing flange studs (key 4) and the faces of the packing flange nuts (key 5) and then install the packing flange nuts.

**For spring-loaded PTFE V-ring packing:** Tighten the packing flange nuts until the shoulder on the packing follower (key 13) contacts the bonnet (key 1).

**For other kinds of packing, except ENVIRO-SEAL and HIGH-SEAL:** Tighten the packing flange nuts to the maximum recommended torque shown in table 5. Then, loosen the packing flange nuts and retighten them to the recommended minimum torque in table 5.

**For ENVIRO-SEAL and HIGH-SEAL packing:** See the Fisher instruction manuals titled ENVIRO-SEAL Packing System for Sliding-Stem Valves (D101643X012) or HIGH-SEAL Live-Loaded Packing System (D102453X012) (as appropriate) for packing instructions.

11. Mount the actuator by following the Actuator Mounting procedure. Check for packing leakage as the valve is being put into service. Retorque the packing flange nuts as required (see table 5). Then, retighten the hex nuts (key 14) to the torque shown in table 6.

Figure 5. Fisher EHD with Bore Seal Trim

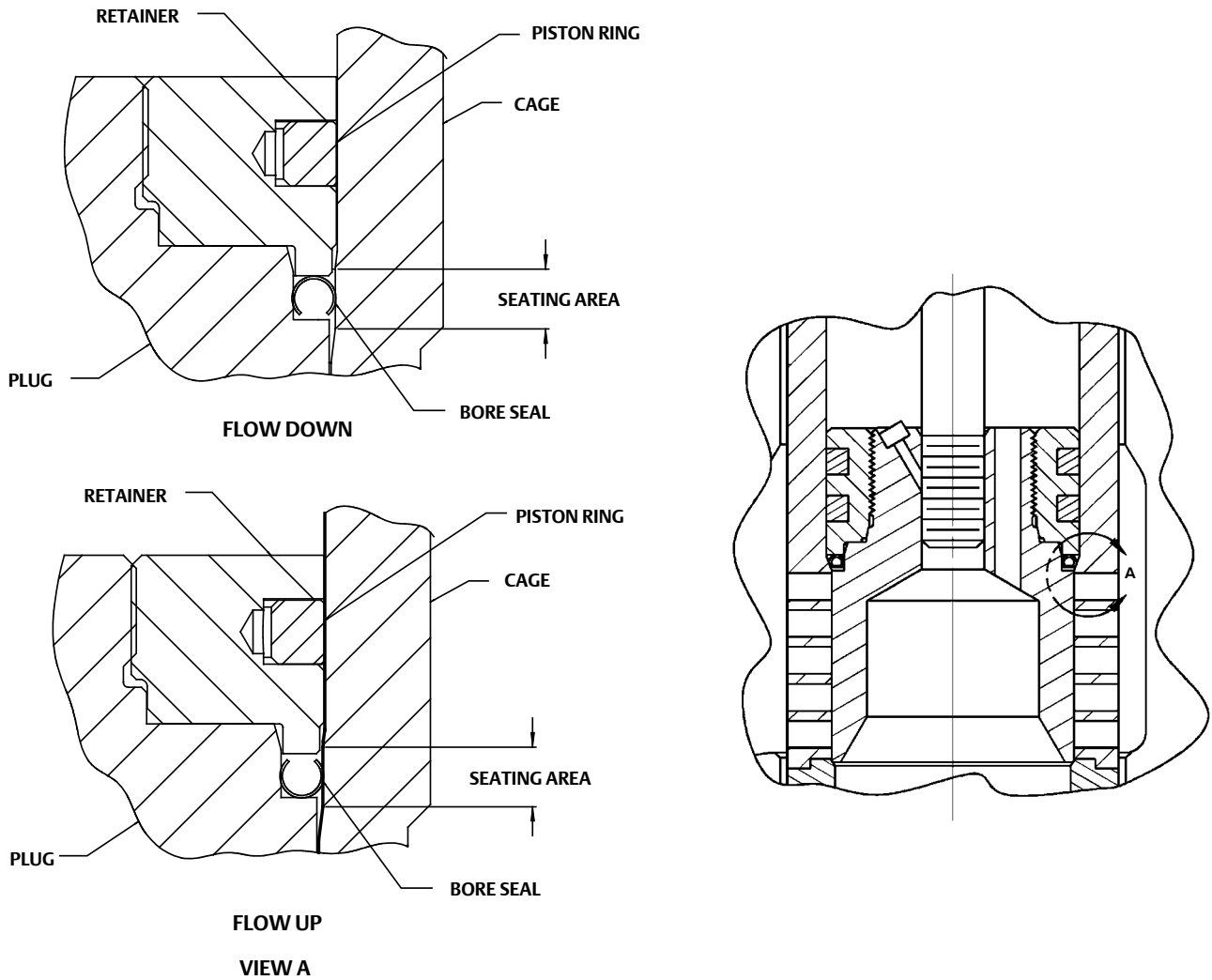



---

## Retrofit: Installing Bore Seal Trim

---

**Note**

Additional actuator thrust is required for a valve with Bore Seal trim. When installing Bore Seal trim in an existing valve, contact your Emerson Process Management sales office for assistance in determining new actuator thrust requirements.

---

Assemble the new valve plug/retainer assembly (with Bore Seal plug seal) using the following instructions:

**CAUTION**

**To avoid leakage when the valve is returned to service, use appropriate methods and materials to protect all sealing surfaces of the new trim parts while assembling the individual parts and during installation in the valve body.**

---

1. Apply a suitable high-temperature lubricant to the inside diameter of the Bore Seal plug seal. Also, lubricate the outside diameter of the valve plug where the Bore Seal plug seal must be pressed into the proper sealing position (figure 5).
2. Orient the Bore Seal plug seal for correct sealing action based on the process fluid flow direction through the valve.
  - The open interior of the Bore Seal plug seal must face up in a valve with flow-up construction (figure 5).
  - The open interior of the Bore Seal plug seal must face down in a valve with flow-down construction (figure 5).
3. Place the Bore Seal plug seal over the top of the valve plug. The retainer will help guide the Bore Seal down onto the plug (figure 5). Do not force the Bore Seal over the plug. For flow down constructions, skip to step 5.
4. An installation tool (see table 8) must be inserted into the Bore Seal prior to using the retainer to guide it down the plug.
5. Apply a suitable high-temperature lubricant to the threads on the plug. Then, place the Bore Seal retainer onto the plug and tighten the retainer using an appropriate tool such as a strap wrench. For flow down constructions, skip to step 7.
6. Remove the retainer and then the installation tool. Place the Bore Seal retainer back onto the plug and tighten the retainer using an appropriate tool such as a strap wrench.
7. Using an appropriate tool such as a center punch, stake the threads on top of the plug in one place (figure 7) to secure the Bore Seal retainer.
8. Install the new plug/retainer assembly with Bore Seal plug seal on the new stem following the appropriate instructions in the Trim Replacement section of this manual.
9. Install piston rings by following instructions in the Trim Replacement section of this manual.
10. Remove the existing valve actuator and bonnet following the appropriate instructions in the Replacing Packing section of this manual.

Figure 6. Bore Seal Installation Tool

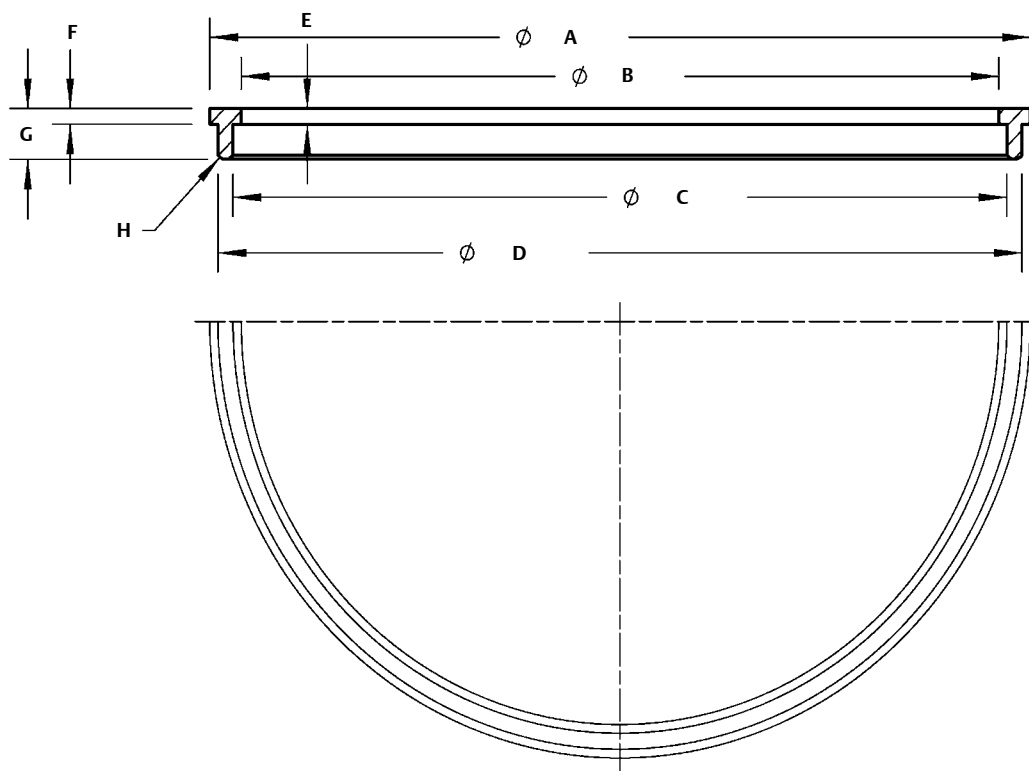

GE22109-A

Table 8. Bore Seal Installation Tool Dimensions

VALVE PORT SIZE, INCH	Dimensions, Inches (See Figure 6)								Tool Part Number
	A	B	C	D	E	F	G	H	
5.375	5.49	5.07	5.17-5.19	5.39-5.37	0.10	0.10	0.32	R.06	GE22109X012
7.00	7.11	6.69	6.79-6.81	7.01-6.99	0.09	0.10	0.32	R.06	GE18264X012
10.00	10.12	9.7	9.80-9.82	10.02-10.00	0.10	0.10	0.32	R.06	GE17914X012

## CAUTION

Do not remove the existing valve stem from the valve plug unless you are planning to replace the valve stem.

Never reuse an old valve stem with a new plug or reinstall a valve stem after it has been removed. Replacing a valve stem requires drilling a new pin hole in the stem. This drilling weakens the stem and may cause failure in service. However, a used valve plug may be reused with a new valve stem.

11. Remove the existing valve stem and plug, cage, and seat ring from the valve body following the appropriate instructions in the Trim Removal section of this manual.
12. Replace all gaskets according to appropriate instructions in the Trim Replacement section of this manual.
13. Install the new seat ring, cage, valve plug/retainer assembly, and stem into the valve body and completely reassemble the valve package following the appropriate instructions in the Trim Replacement section of this manual.

**CAUTION**

To avoid excessive leakage and seat erosion, the valve plug must be initially seated with sufficient force to overcome the resistance of the Bore Seal plug seal and contact the seat ring. You can correctly seat the valve plug by using the same force calculated for full load when sizing your actuator. With no pressure drop across the valve, this force will adequately drive the valve plug to the seat ring, thus giving the Bore Seal plug seal a predetermined permanent set. Once this is done, the plug/retainer assembly, the cage, and the seat ring become a matched set.

With full actuator force applied and the valve plug fully seated, align the actuator travel indicator scale with the lower end of valve travel. Refer to the appropriate actuator instruction manual for information on this procedure.

## Replacement of Installed Bore Seal Trim

### Trim Removal (Bore Seal Constructions)

1. Remove the valve actuator and bonnet following the appropriate instructions in the Replacing Packing section of this manual.

**CAUTION**

To avoid leakage when the valve is returned to service, use appropriate methods and materials to protect all sealing surfaces of the trim parts during maintenance.

Use caution when removing piston ring(s) and the Bore Seal plug seal to avoid scratching any sealing surface.

**CAUTION**

Do not remove the valve stem from the plug/retainer assembly unless you are planning to replace the valve stem.

Never reuse an old valve stem with a new plug or reinstall a valve stem after it has been removed. Replacing a valve stem requires drilling a new pin hole in the stem. This drilling weakens the stem and may cause failure in service. However, a used valve plug may be reused with a new valve stem.

2. Remove the plug/retainer assembly (with Bore Seal plug seal), cage, and seat ring from the valve body following the appropriate instructions in the Trim Removal section of this manual.
3. Locate the staked thread on top of the valve plug (figure 7). The staked thread secures the retainer. Use a drill with a 1/8 inch bit to drill out the staked area of the thread. Drill approximately 1/8 inch into the metal to remove the staking.
4. Locate the break between sections of the piston ring(s). Using an appropriate tool such as a flat-blade screwdriver, carefully pry out the piston ring(s) from the groove(s) in the Bore Seal retainer.
5. After removing the piston ring(s), locate the 1/4-inch diameter hole in the groove. In a retainer with two piston ring grooves, the hole will be found in the upper groove.
6. Select an appropriate tool such as a punch and place the tip of the tool into the hole with the body of the tool held tangent to the outside diameter of the retainer. Strike the tool with a hammer to rotate the retainer and free it from the valve plug. Remove the retainer from the plug.

Figure 7. Stake the Threads of the Bore Seal Retainer

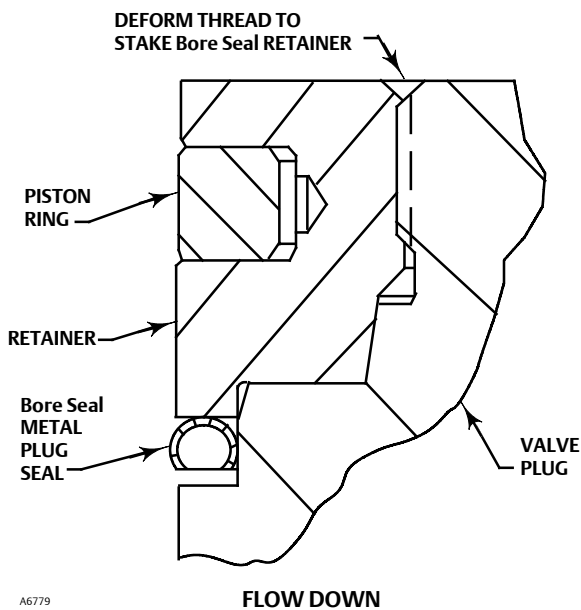

A6779

Figure 8. Installing the Bore Seal Plug Seal Using the Installation Tool

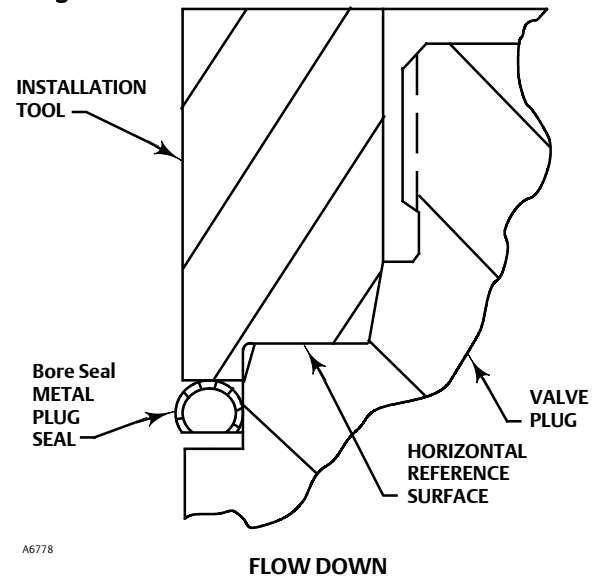

A6778

NOTE: PRESS THE INSTALLATION TOOL OVER THE VALVE PLUG UNTIL THE TOOL CONTACTS THE HORIZONTAL REFERENCE SURFACE OF THE VALVE PLUG.

7. Use an appropriate tool such as a flat-blade screwdriver to pry the Bore Seal plug seal off the plug. Use caution to avoid scratches or other damage to the sealing surfaces where the Bore Seal plug seal makes contact with the valve plug (figure 9).
8. Inspect the lower seating surface where the valve plug contacts the seat ring for wear or damage which would prevent proper operation of the valve. Also, inspect the upper seating surface inside the cage where the Bore Seal plug seal contacts the cage, and inspect the sealing surface where the Bore Seal plug seal makes contact with the plug (figure 9).
9. Replace or repair trim parts according to the following procedure for lapping metal seats, remachining metal seats, or other valve plug maintenance procedures as appropriate.

### Lapping Metal Seats (Bore Seal Constructions)

Before installing a new Bore Seal plug seal, lap the lower seating surface (valve plug to seat ring, figure 9) following appropriate procedures in the Lapping Seats section of this manual.

### Remachining Metal Seats (Bore Seal Constructions)

A valve plug with a Bore Seal metal plug seal features two seating surfaces. One seating surface is found where the valve plug contacts the seat ring. The second seating surface is found where the Bore Seal plug seal contacts the upper seating surface in the cage. The cage does not require any machining, even when the plug and / or seat ring have been machined.

### Trim Replacement (Bore Seal Constructions)

1. Apply a suitable high-temperature lubricant to the inside diameter of the Bore Seal plug seal. Also, lubricate the outside diameter of the valve plug where the Bore Seal plug seal must be pressed into the proper sealing position (figure 5).
2. Orient the Bore Seal plug seal for correct sealing action based on the process fluid flow direction through the valve.

- The open interior of the Bore Seal plug seal must face up in a valve with flow-up construction (figure 5).
- The open interior of the Bore Seal plug seal must face down in a valve with flow-down construction (figure 5).

Figure 9. Lower (Valve Plug to Seat Ring) and Upper (Bore Seal Plug Seal to Cage) Seating Surfaces

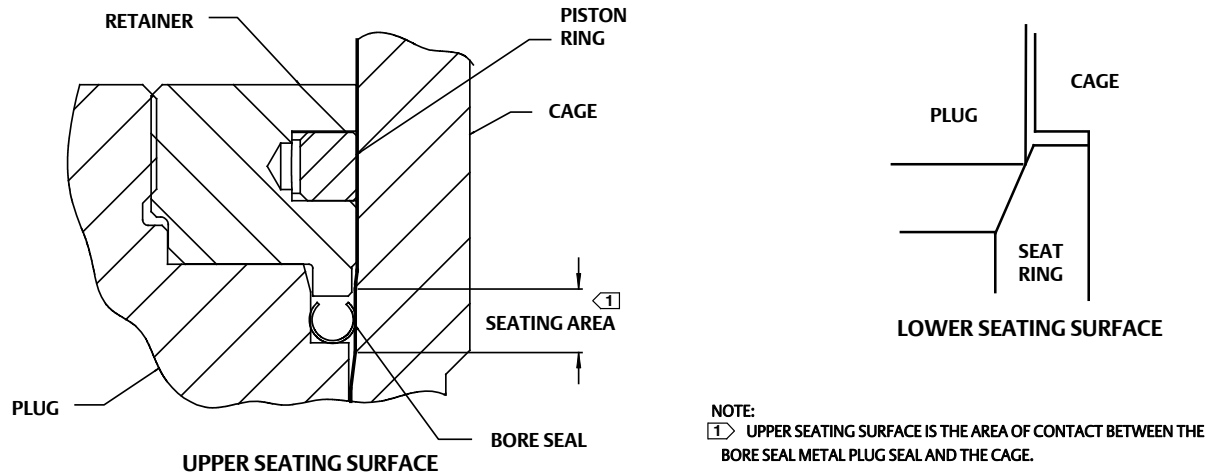

3. Place the Bore Seal plug seal over the top of the valve plug. The retainer will help guide the Bore Seal down onto the plug. Do not force the Bore Seal over the plug. For flow down constructions, skip to step 5.
4. An installation tool (see table 8) must be inserted into the Bore Seal prior to using the retainer to guide it down the plug.
5. Apply a suitable high-temperature lubricant to the threads on the plug. Then, place the Bore Seal retainer onto the plug and tighten the retainer using an appropriate tool such as a strap wrench. For flow down constructions, skip to step 7.
6. Remove the retainer and then the installation tool. Place the Bore Seal retainer back onto the plug and tighten the retainer using an appropriate tool such as a strap wrench.
7. Using an appropriate tool such as a center punch, stake the threads on top of the plug in one place (figure 7) to secure the Bore Seal retainer.
8. Replace the piston ring(s) following instructions in the Trim Replacement section of this manual.
9. Return the seat ring, cage, plug/retainer assembly, and stem to the valve body and completely reassemble the valve package following the appropriate instructions in the Trim Replacement section of this manual.

## CAUTION

To avoid excessive leakage and seat erosion, the valve plug must be initially seated with sufficient force to overcome the resistance of the Bore Seal plug seal and contact the seat ring. You can correctly seat the valve plug by using the same force calculated for full load when sizing your actuator. With no pressure drop across the valve, this force will adequately drive the valve plug to the seat ring, thus giving the Bore Seal plug seal a predetermined permanent set. Once this is done, the plug/retainer assembly, the cage, and the seat ring become a matched set.

With full actuator force applied and the valve plug fully seated, align the actuator travel indicator scale with the lower end of valve travel. Refer to the appropriate actuator instruction manual for information on this procedure.

## Actuator Mounting

The following procedure assumes that the valve and actuator are fully assembled, but with the actuator removed from the valve. Unless otherwise identified, the parts involved in making up the actuator-valve stem connection are shown in figure 3.

### CAUTION

**Never use a wrench or pliers on the valve plug stem and never turn the valve plug stem while the valve plug assembly is seated. A damaged stem could cut the packing and allow leakage. Turning the plug while seated could damage the seats allowing leakage at shutoff.**

1. Turn the stem locknuts onto the valve stem.
2. Move the valve plug to the closed position.
3. Place the actuator on the bonnet and secure with the hex nuts (key 26, figure 11). Connect supply pressure to the actuator.
4. Make sure the actuator stem is fully retracted. With a properly assembled direct-acting spring-return actuator, spring compression forces the actuator stem to the fully retracted position. A double-acting piston actuator or a reverse-acting spring-return actuator requires air pressure (or a side-mounted handwheel) to stroke the actuator stem to the fully retracted position.
5. Extend the actuator stem a distance equal to the travel (as specified on the nameplate).
6. Attach both halves of the stem connector, making sure the connector fully engages both the actuator threads and valve plug stem threads. Install the cap screws in the stem connector, but tighten them only slightly at this time.
7. Stroke the valve to the fully open position. The travel indicator should show the valve to be wide open. If it does not, loosen the screws that hold the travel indicator scale, and shift the scale to the required position.
8. Stroke the valve to the closed position. The travel indicator should show the valve to be closed.
9. If travel is not correct, lift the valve plug assembly (key 3, figure 12 or 14) off its seat approximately 6.4 mm (1/4 inch) and screw the valve plug stem into or out of the stem connector as follows. To lengthen travel, turn the valve plug stem into the stem connector slightly. To shorten travel, turn the valve plug stem out of the stem connector slightly. (Turning it out too far will limit the stroke.)
10. After adjusting the stem connection so that the actuator will properly stroke the valve plug assembly, tighten the cap screws in the stem connector, tightening the one opposite the anti-rotation groove first. Then lock the stem locknuts against the stem connector.

## Parts Ordering

Each valve is assigned a serial number, which can be found on the valve body. This same number also appears on the actuator nameplate when the valve is shipped from the factory as part of a control valve assembly. Refer to the number when contacting your Emerson Process Management sales office for technical assistance or when ordering replacement parts.

When ordering replacement parts, also be sure to include the 11-character part number for each part required from the following parts list.

### ⚠ WARNING

**Use only genuine Fisher replacement parts. Components that are not supplied by Emerson Process Management should not, under any circumstances, be used in any Fisher valve, because they may void your warranty, might adversely affect the performance of the valve, and could cause personal injury and property damage.**

## Parts Kits

### ENVIRO-SEAL Packing Retrofit Kits

Retrofit kits include parts to convert existing packing to the ENVIRO-SEAL packing system. PTFE kits include keys 200, 201, 211, 212, 214, 215, 217, 218, tag, and cable tie. Graphite kits include keys 200, 201, 207, 208, 209, 210, 211, 212, 214, 216, 217, tag, and cable tie. Duplex kits include keys 200, 201, 207, 209, 211, 212, 214, 215, 216, 217, tag, and cable tie. Stems and packing box constructions that do not meet Emerson Process Management stem finish specifications, dimensional tolerances, and design specifications, may adversely alter the performance of the packing kit.

Stem Diameter mm (Inches)	Yoke Boss Diameter mm (Inches)	Kits Packing Material		
		Double PTFE	Graphite ULF	Duplex
31.8 (1-1/4)	127 (5, 5H)	RPACKXRT052	RPACKXRT302	RPACKXRT252

### ENVIRO-SEAL Packing Repair Kits

Repair kits include parts to replace the “soft” packing materials in valves that already have ENVIRO-SEAL packing arrangements installed or in valves that have been upgraded with ENVIRO-SEAL retrofit kits. PTFE repair kits include keys 214, 215, and 218. Graphite repair kits include keys 207, 208, 209, 210, and 214. Duplex repair kits include keys 207, 209, 214, and 215.

Stem Diameter mm (Inches)	Yoke Boss Diameter mm (Inches)	Kits Packing Material		
		Double PTFE	Graphite ULF	Duplex
31.8 (1-1/4)	127 (5, 5H)	RPACKX00232	RPACKX00632	RPACKX00332

Figure 10. Live-Loaded Packing

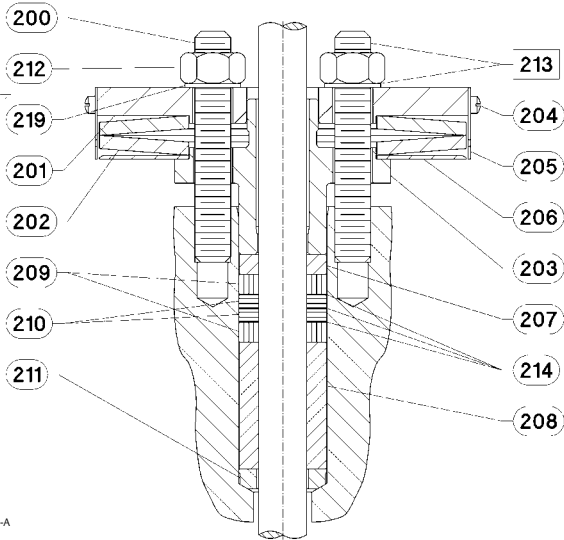

3984153-A

Typical HIGH-SEAL ULF Packing System

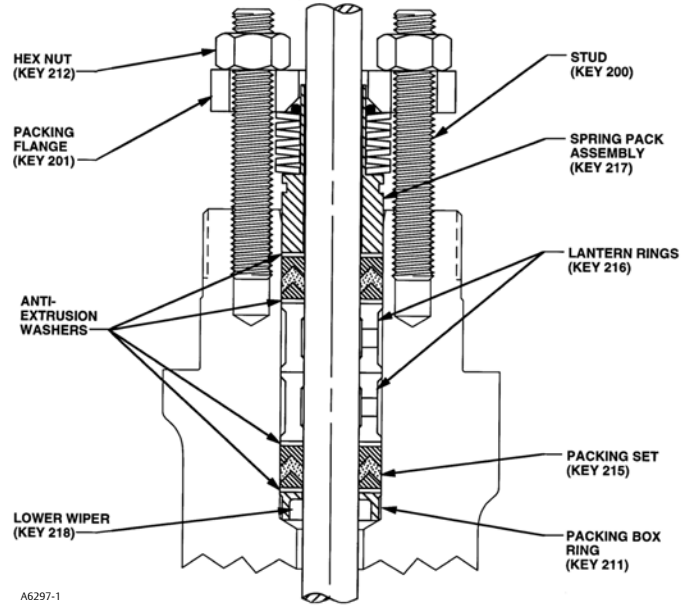

A6297-1

Typical ENVIRO-SEAL Packing System  
with PTFE Packing

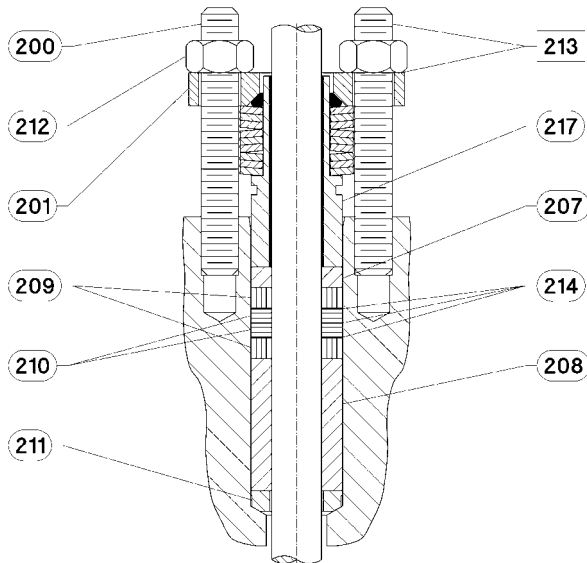

3984612/A

Typical ENVIRO-SEAL Packing System  
with Graphite ULF Packing

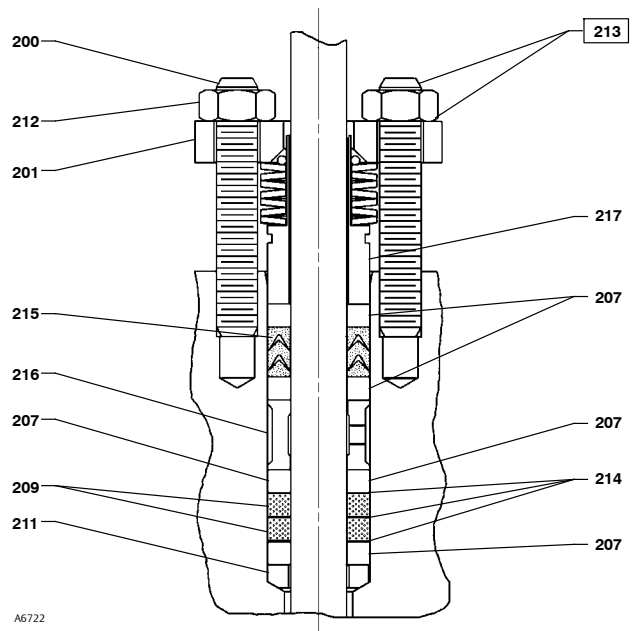

A6722

Typical ENVIRO-SEAL Packing System  
with Duplex Packing



Figure 11. Bonnet Assembly

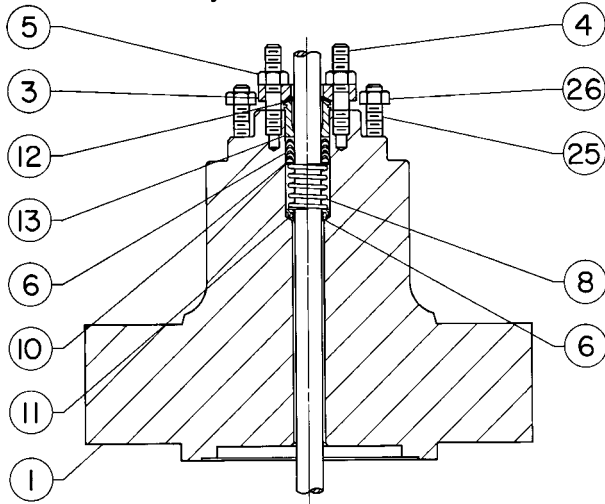

35A3976-A

## Parts List

**Note**

Part numbers are shown for recommended spares only. For part numbers not shown, contact your Emerson Process Management sales office.

### Bonnet Assembly (figures 4 and 11)

Key	Description	Part Number	Key	Description	Part Number
1	Bonnet If you need a bonnet as a replacement part, order by valve size and stem diameter, serial number, and desired material.		8	Spring or Lantern Ring	See following table
3	Packing Flange		9*	Packing Ring	See following table
4	Packing Flange Stud 127 mm (5-inch) yoke boss diameter (2 req'd) 178 mm (7-inch) yoke boss diameter (3 req'd)		10	Washer	See following table
5	Packing Flange Nut 127 mm (5-inch) yoke boss diameter (2 req'd) 178 mm (7-inch) yoke boss diameter (3 req'd)		11*	Packing Box Ring	See following table
6*	Packing Set	See following table	12*	Upper Wiper, felt	See following table
7*	Packing Ring	See following table	13	Packing Follower, 316 stainless steel	See following table
			14	Pipe Plug (not shown) Steel 316 stainless steel	
			14	Lubricator, steel (not shown)	
			14	Lubricator/Isolating Valve (not shown)	
			25	Actuator Mounting Stud, steel (8 req'd)	
			26	Hex Nut, steel (8 req'd)	
			30*	Lower Wiper, PTFE	See following table
			31*	Male Adapter, PTFE	See following table
			32*	Female Adapter, PTFE/glass	See following table

\*Recommended spare parts

## Keys 6, 7, 9, 12, 30, 31 and 32 Soft Packing Parts\*

VALVE STEM CONNECTION		PACKING ARRANGEMENT	KEY NUMBER	PACKING PART DESCRIPTION	QUANTITY	PART NUMBER
mm	Inches					
31.8	1-1/4	PTFE, single packing	6	Packing set (includes keys 7, 30, 31 & 32) Male Adapter Female Adapter V-ring Lower Wiper Upper Wiper	1	1R290801012
			31		1	1H995701012
			32		1	1H995801012
			7		3	1D387601012
			30		1	1J872506992
			12		1	1J873006332
		PTFE, double packing	6	Packing set (includes keys 7, 30, 31, & 32) Male Adapter Female Adapter V-ring Lower Wiper Upper Wiper	2	1R290801012
			31		2	1H995701012
			32		2	1H995801012
			7		6	1K387601012
		Low chloride-graphite laminate and filament, single packing	30	Graphite Filament Packing Rings Graphite Laminate Packing Rings	2	1J872506992
			12		1	1J873006332
		Low chloride-graphite laminate and filament, double packing	7	Graphite Filament Packing Rings Graphite Laminate Packing Rings	3	1D7520X0162
			7		2	1V5666X0022
Graphite-composition, double packing	7	Graphite Filament Packing Rings Graphite Laminate Packing Rings	5	1D7520X0162		
	7		3	1V5666X0022		
PTFE-composition, double packing	7	Packing Rings Packing Rings Upper Wiper	2	1D752001052		
	7		3	1D751901052		
PTFE-composition, double packing	12	Upper Wiper	1	1J873006332		
	7		8	1D7520X0012		
PTFE-composition, double packing	12	Upper Wiper	1	1J873006332		
	7		7	1D7520X0012		
50.8	2	Low chloride-graphite laminate and filament, single packing	7	Graphite Laminate Packing Rings Graphite Filament Packing Rings	3	10A4801X022
			9		4	1N2600X0042
		Low chloride-graphite laminate and filament, double packing	7	Graphite Laminate Packing Rings Graphite Filament Packing Rings	3	10A4801X022
			9		4	1N2600X0042
		Graphite-composition, double packing	7	Packing Rings Upper Wiper	7	1N2600X0032
			12		1	1V313206332
		PTFE-composition, double packing	7	Packing Rings Upper wiper	7	1N260001042
			12		1	1V313206332

## Keys 8, 10, 11\*, and 13 Metal Packing Parts

VALVE STEM CONNECTION		PACKING TYPE	KEY NUMBER	PACKING PART DESCRIPTION	QUANTITY REQUIRED	MATERIAL
mm	Inches					316 Stainless Steel
31.8	1-1/4	PTFE, single packing	8	Spring	1	1D387437012
			10	Washer	1	1H995936042
			11	Packing box ring	1	1J873535072
			13	Packing follower	1	1H998435072
		Graphite laminate and filament, double packing	8	Lantern ring	2	0W087135072
			11	Packing box ring	1	1J873535072
			13	Packing follower	1	1H998435072
				Warning Tag	1	11B9513X012
		PTFE, PTFE-composition, graphite-composition, graphite laminate and filament, double packing	8	Lantern ring	1	0W087135072
			11	Packing box ring	1	1J873535072
			13	Packing follower	1	1H998435072
				Warning Tag	1	11B9513X012
50.8	2	Graphite laminate and filament, single packing PTFE-composition, graphite-composition, graphite laminate and filament, double packing	8	Lantern ring	1	1V313335072
			11	Packing box ring	1	1V312735072
			13	Packing follower	1	1V312835072
				Warning Tag	1	11B9513X012



Figure 12. Fisher EHD Valve

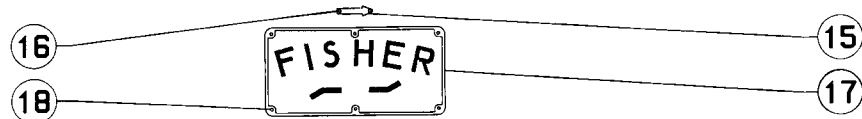

FLOW DIRECTION FOR ALL TRIMS EXCEPT THOSE WITH WHISPER TRIM III CAGES

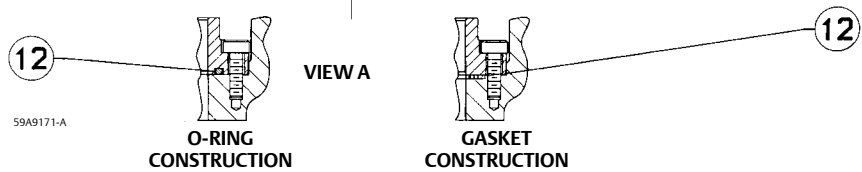
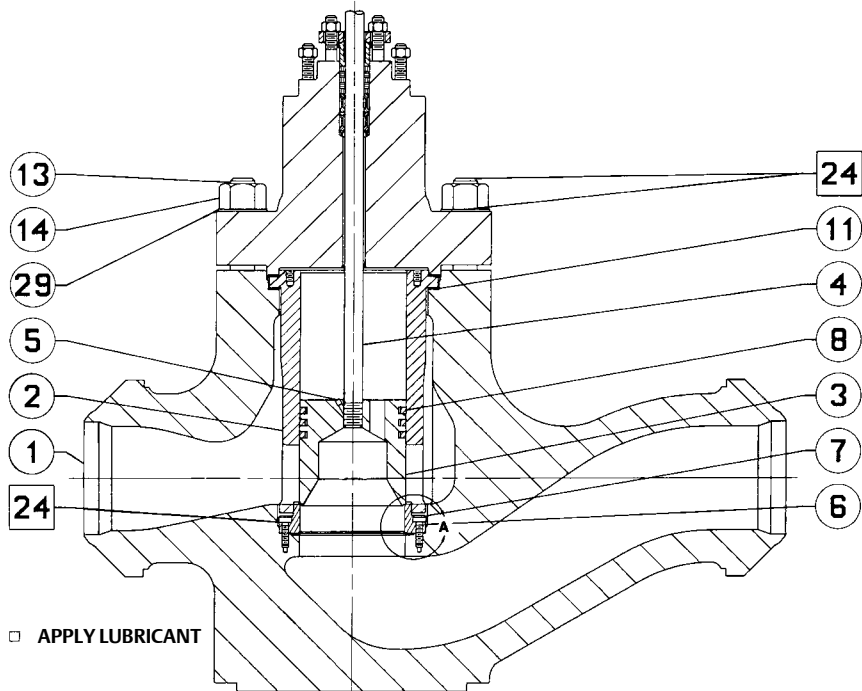

COMPLETE VALVE SHOWING VALVE PLUG WITHOUT DIVERTER CONE

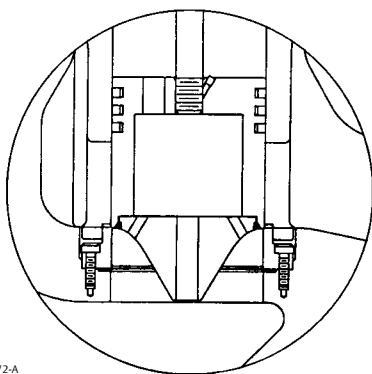

DIVERTER CONE DETAIL

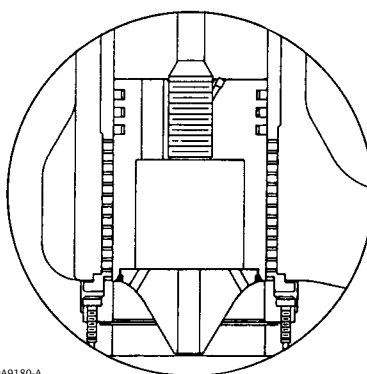

WHISPER TRIM  
LEVEL A, B, OR C DETAIL

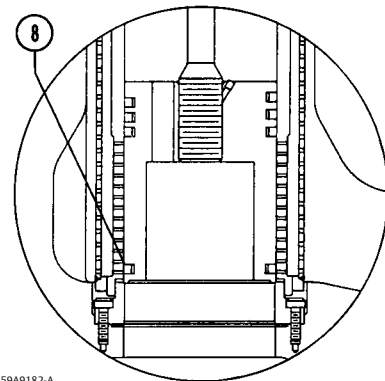

WHISPER TRIM  
LEVEL D DETAIL

Figure 13. Belleville Washer Body-to-Bonnet Bolting

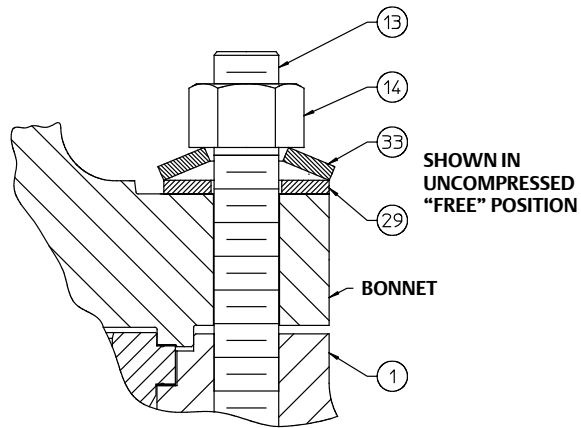

GE60624-C

Figure 14. Fisher EHT Valve



FLOW DIRECTION FOR ALL TRIMS EXCEPT THOSE WITH WHISPER TRIM III CAGES

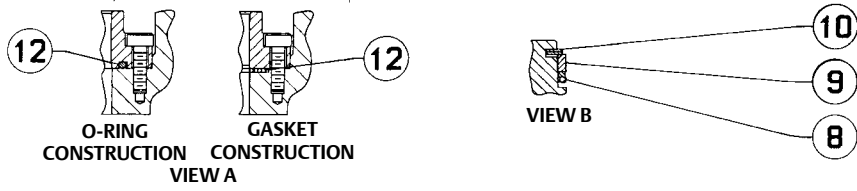
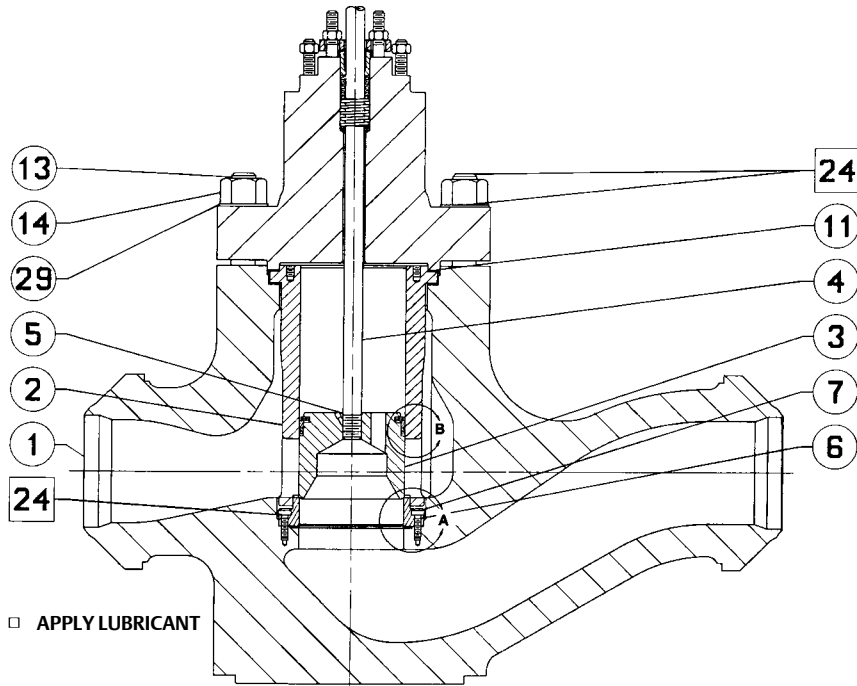

COMPLETE VALVE SHOWING VALVE PLUG WITHOUT DIVERTER CONE

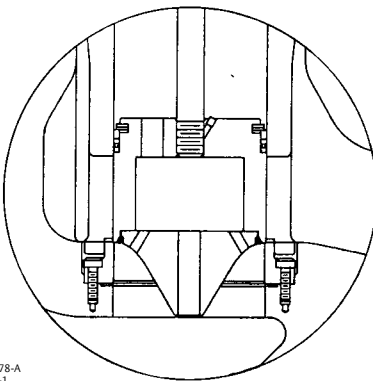

DIVERTER CONE DETAIL

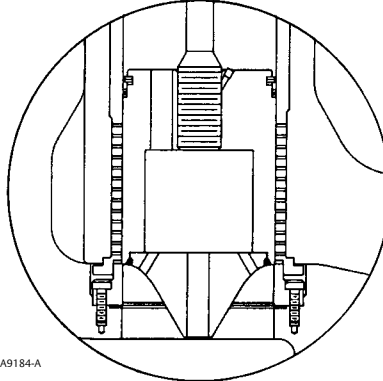

WHISPER TRIM LEVEL A, B, OR C DETAIL

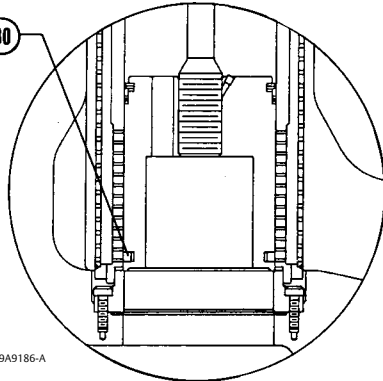

WHISPER TRIM LEVEL D DETAIL

Key	Description	Part Number
11*	Cage Gasket (2 req'd) For standard service, silver pl N04400 NPS 8 and 10 valves CL1500 CL2500 NPS 12 and 14 valves CL1500 CL2500 For sour gas service, tin pl N04400 NPS 8 and 10 valves CL1500 CL2500 NPS 12 and 14 valves CL1500 CL2500	29A9220X012 29A9221X012 29A9222X012 29A9223X012 29A9220X022 29A9221X022 29A9222X022 29A9223X022
12*	Seat Ring Gasket Spiral wound N06600 NPS 8 and 10 valves CL1500 CL2500 NPS 12 and 14 valves CL1500 CL2500	19A7468X012 19A7469X012 19A7470X012 19A7471X012
12*	Seat Ring O-Ring NPS 8 and 10 valves CL1500 Nitrile Ethylene/propylene Fluorocarbon CL2500 Nitrile Ethylene/propylene Fluorocarbon NPS 12 and 14 valves CL1500 Nitrile Ethylene/propylene Fluorocarbon CL2500 Nitrile Ethylene/propylene Fluorocarbon	1D5470X0032 1D5470X0042 1D5470X0012 19A9013X012 19A9013X042 19A9013X032 19A9014X012 19A9014X042 19A9014X032 1D5470X0032 1D5470X0042 1D5470X0012
13	Bonnet Stud (12 required)	

Figure 15. Fisher EHT Valve Using PEEK Anti-Extrusion Rings

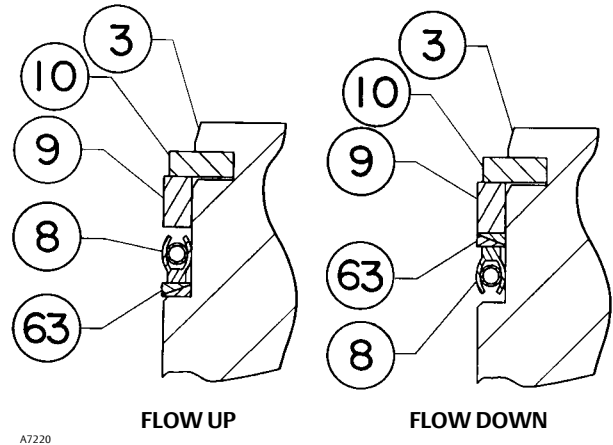

Key	Description	Part Number
14	Hex Nut (12 req'd)	
15	Flow Arrow, stainless steel	
16	Drive Screw, stainless steel (2 req'd)	
17	Nameplate, stainless steel	
18	Drive Screw, stainless steel (6 req'd)	
24	Anti-seize lubricant, (not furnished with valve)	
29	Flat Washer (12 req'd)	
30*	Piston Ring, graphite (for EHD valve with Level D Whisper Trim III cage only)	
	NPS 8 and 10 valves	1U5069X0012
	CL1500	11A9727X022
	CL2500	
	NPS 12 and 14 valves	
	CL1500	15A3945X012
	CL2500	1U5069X0012
33	Belleville Washer, N07718 (12 req'd)	
63	Anti-Extrusion Ring	

Key 2\* Cage for Valve without Whisper Trim III Cage

VALVE SIZE, NPS	VALVE RATING	CAGE CONSTRUCTION	MATERIAL				
			CA6NM	CA6NM, Cr Ct		316 Stainless Steel	
				To 427° C (800° F)	Above 427° C (800° F)	Cr Ct, for Standard Service	ENC, for Sour Gas Service
8, 10	CL1500	Equal percentage	49A7423X012	49A7424X012	49A7425X012	49A7424X022	49A9000X012
		Linear	39A7420X012	39A7421X012	39A7422X012	39A7421X022	39A9001X012
		Modified equal percentage	49A7423X012	49A7424X012	49A7425X012	49A7424X022	49A9000X012
	CL2500	Equal percentage	49A7429X012	49A7430X012	49A7431X012	49A7430X022	49A9002X012
		Linear	39A7426X012	39A7427X012	39A7428X012	39A7427X022	39A9003X012
		Modified equal percentage	49A7429X012	49A7430X012	49A7431X012	49A7430X022	49A9002X012
12, 14	CL1500	Equal percentage	39A7435X012	39A7436X012	39A7437X012	39A7436X022	---
		Linear	39A7432X012	39A7433X012	39A7434X012	39A7433X022	---
		Modified equal percentage	39A7435X012	39A7436X012	39A7437X012	39A7436X022	---
	CL2500	Equal percentage	49A7441X012	49A7442X012	49A7443X012	49A7442X022	---
		Linear	39A7438X012	39A7439X012	39A7440X012	39A7439X022	---
		Modified equal percentage	49A7441X012	49A7442X012	49A7443X012	49A7442X022	---

\*Recommended spare parts

Key 2\* Whisper Trim III Cage

VALVE SIZE, NPS	CAGE CONSTRUCTION	Cr Ct M152 SST		17-4PH STAINLESS STEEL WITH H1150 DBL HEAT-TREATMENT FOR SOUR GAS SERVICE	
		CL1500 Rating	CL2500 Rating	CL1500 Rating	CL2500 Rating
8, 10	Level A1	30B1118X012	30B1130X012	30B1119X012	30B1131X012
	Level A3	30B1120X012	30B1132X012	30B1121X012	30B1133X012
	Level B1	30B1122X012	30B1134X012	30B1123X012	30B1135X012
	Level B3	30B1124X012	30B1136X012	30B1125X012	30B1137X012
	Level C1	30B1126X012	30B1138X012	30B1127X012	30B1139X012
	Level C3	30B1128X012	30B1140X012	30B1129X012	30B1141X012
	Level D1 <sup>(1)</sup>	30B1185X012	30B1189X012	30B1186X012	30B1190X012
	Level D3 <sup>(1)</sup>	30B1185X022	30B1189X022	30B1186X022	30B1190X022
12, 14	Level A1	30B1142X012	30B1154X012	30B1143X012	30B1155X012
	Level A3	30B1144X012	30B1156X012	30B1145X012	30B1157X012
	Level B1	30B1146X012	30B1158X012	30B1147X012	30B1159X012
	Level B3	30B1148X012	30B1160X012	30B1149X012	30B1161X012
	Level C1	30B1150X012	30B1162X012	30B1151X012	30B1163X012
	Level C3	30B1152X012	30B1164X012	30B1153X012	30B1165X012
	Level D1 <sup>(1)</sup>	30B1193X012	30B1197X012	30B1194X012	30B1198X012
	Level D3 <sup>(1)</sup>	30B1193X022	30B1197X022	30B1194X022	30B1198X022

1. This part number represents a cage and baffle assembly.

Key 3\* Valve Plug for Valve without Whisper Trim III Cage

VALVE SIZE, NPS	VALVE RATING	VALVE/PLUG DESIGN	VALVE STEM CONNECTION SIZE		HEAT TREATED 420 STAINLESS STEEL (EHD OR EHT)	316 STAINLESS STEEL WITH ALLOY 6 (CoCr-A) SEAT AND GUIDE		
			mm	Inches		For Use Only with Cr Ct 316 SST Cage	For Service Above 121°C (250°F)	
8, 10	CL1500	EHD w/o diverter cone	31.8	1-1/4	35A3998X012	35A4001X012	35A4002X012	
			50.8	2	35A3997X012	35A4003X012	35A4004X012	
		EHD with diverter cone	50.8	2	---	39A9047X012	39A9048X012	
		EHT w/o diverter cone	31.8	1-1/4	35A3991X012	35A4005X012	35A4006X012	
	CL2500		50.8	2	35A3992X012	35A4007X012	35A4008X012	
		EHT with diverter cone	50.8	2	---	39A9049X012	39A9050X012	
		EHD w/o diverter cone	31.8	1-1/4	35A3963X012	35A3970X012	35A3971X012	
			50.8	2	39A7494X012	39A7495X012	39A7496X012	
CL2500		EHD with diverter cone	50.8	2	---	39A9043X012	39A9044X012	
		EHT w/o diverter cone	31.8	1-1/4	35A3962X012	35A3968X012	35A3969X012	
		50.8	2	39A7497X012	39A7498X012	39A7499X012		
		EHT with diverter cone	50.8	2	---	39A9045X012	39A9046X012	
12, 14	CL1500	EHD w/o diverter cone	31.8	1-1/4	35A3926X012	35A3937X012	35A3938X012	
			50.8	2	35A3927X012	35A3939X012	35A3940X012	
		EHD with diverter cone	50.8	2	---	39A9051X012	39A9052X012	
		EHT w/o diverter cone	31.8	1-1/4	35A3924X012	35A3935X012	35A3936X012	
	CL2500		50.8	2	35A3925X012	35A3941X012	35A3942X012	
			EHT with diverter cone	50.8	2	---	39A9053X012	39A9054X012
			EHD w/o diverter cone	31.8	1-1/4	35A3998X012	35A4001X012	35A4002X012
			50.8	2	35A3997X012	35A4003X012	35A4004X012	
CL2500		EHD with diverter cone	50.8	2	---	39A9047X012	39A9048X012	
		EHT w/o diverter cone	31.8	1-1/4	35A3991X012	35A4005X012	35A4006X012	
		50.8	2	35A3992X012	35A4007X012	35A4008X012		
		EHT with diverter cone	50.8	2	---	39A9049X012	39A9050X012	



Key 3\* Valve Plug for NPS 8 or 10 Fisher EHD with Whisper Trim III Cage

MATERIAL	OPERATING TEMPERATURE LIMITS		VALVE STEM CONNECTION		VALVE RATING			
	°C	°F	mm	Inches	CL1500		CL2500	
					Level A, B, or C	Level D	Level A, B, or C	Level D
17-4PH stainless steel, H900 heat-treated	-29 to 427	-20 to 800	31.8	1-1/4	---	39A9122X012	---	39A9137X012
			50.8	2	---	39A9124X012	---	39A9139X012
316 stainless steel, alloy 6 (CoCr-A) seat and guide	-29 to 149	-20 to 300	31.8	1-1/4	39A9130X012	39A9126X012	39A9145X012	39A9141X012
			50.8	2	39A9132X012	39A9128X012	39A9147X012	39A9143X012
	93 to 204	200 to 400	31.8	1-1/4	39A9130X022	39A9126X022	39A9145X022	39A9141X022
			50.8	2	39A9132X022	39A9128X022	39A9147X022	39A9143X022
	149 to 260	300 to 500	31.8	1-1/4	39A9130X032	39A9126X032	39A9145X032	39A9141X032
			50.8	2	39A9132X032	39A9128X032	39A9147X032	39A9143X032
	204 to 316	400 to 600	31.8	1-1/4	39A9130X042	39A9126X042	39A9145X042	39A9141X042
			50.8	2	39A9132X042	39A9128X042	39A9147X042	39A9143X042
	260 to 371	500 to 700	31.8	1-1/4	39A9130X052	39A9126X052	39A9145X052	39A9141X052
			50.8	2	39A9132X052	39A9128X052	39A9147X052	39A9143X052
	316 to 427	600 to 800	31.8	1-1/4	39A9130X062	39A9126X062	39A9145X062	39A9141X062
			50.8	2	39A9132X062	39A9128X062	39A9147X062	39A9143X062
	371 to 482	700 to 900	31.8	1-1/4	39A9130X072	39A9126X072	39A9145X072	39A9141X072
			50.8	2	39A9132X072	39A9128X072	39A9147X072	39A9143X072
	427 to 538	800 to 1000	31.8	1-1/4	39A9130X082	39A9126X082	39A9145X082	39A9141X082
			50.8	2	39A9132X082	39A9128X082	39A9147X082	39A9143X082
	482 to 593	900 to 1100	31.8	1-1/4	39A9130X092	39A9126X092	39A9145X092	39A9141X092
			50.8	2	39A9132X092	39A9128X092	39A9147X092	39A9143X092
N06600, alloy 6 (CoCr-A) seat and guide	-29 to 232	-20 to 450	31.8	1-1/4	39A9130X102	39A9126X102	39A9145X102	39A9141X102
			50.8	2	39A9132X102	39A9128X102	39A9147X102	39A9143X102
	233 to 427	451 to 800	31.8	1-1/4	39A9130X112	39A9126X112	39A9145X112	39A9141X112
			50.8	2	39A9132X112	39A9128X112	39A9147X112	39A9143X112
	428 to 593	801 to 1100	31.8	1-1/4	39A9130X122	39A9126X122	39A9145X122	39A9141X122
			50.8	2	39A9132X122	39A9128X122	39A9147X122	39A9143X122
17-4 stainless steel, H1150 heat-treated, alloy 6 (CoCr-A) seat and guide	-29 to 427	-20 to 800	31.8	1-1/4	39A9130X132	39A9126X132	39A9145X132	39A9141X132
			50.8	2	39A9132X132	39A9128X132	39A9147X132	39A9143X132
17-4 stainless steel, H1150 DBL heat-treated, alloy 6 (CoCr-A) seat and guide, for sour gas service	-29 to 232	-20 to 450	31.8	1-1/4	39A9130X142	39A9126X142	39A9145X142	39A9141X142
			50.8	2	39A9132X142	39A9128X142	39A9147X142	39A9143X142

\*Recommended spare parts

Key 3\* Valve Plug for NPS 12 or 14 Fisher EHD with Whisper Trim III Cage

MATERIAL	OPERATING TEMPERATURE LIMITS		VALVE STEM CONNECTION		VALVE RATING			
	°C	°F	mm	Inches	CL1500		CL2500	
					Level A, B, or C	Level D	Level A, B, or C	Level D
17-4PH stainless steel, H900 heat-treated	-29 to 427	-20 to 800	31.8	1-1/4	---	39A9151X012	---	39A9122X012
			50.8	2	---	39A9153X012	---	39A9124X012
316 stainless steel, alloy 6 (CoCr-A) seat and guide	-29 to 149	-20 to 300	31.8	1-1/4	39A9159X012	39A9155X012	39A9130X012	39A9126X012
			50.8	2	39A9161X012	39A9157X012	39A9132X012	39A9128X012
	93 to 204	200 to 400	31.8	1-1/4	39A9159X022	39A9155X022	39A9130X022	39A9126X022
			50.8	2	39A9161X022	39A9157X022	39A9132X022	39A9128X022
	149 to 260	300 to 500	31.8	1-1/4	39A9159X032	39A9155X032	39A9130X032	39A9126X032
			50.8	2	39A9161X032	39A9157X032	39A9132X032	39A9128X032
	204 to 316	400 to 600	31.8	1-1/4	39A9159X042	39A9155X042	39A9130X042	39A9126X042
			50.8	2	39A9161X042	39A9157X042	39A9132X042	39A9128X042
	260 to 371	500 to 700	31.8	1-1/4	39A9159X052	39A1955X052	39A9130X052	39A9126X052
			50.8	2	39A9161X052	39A9157X052	39A9132X052	39A9128X052
	316 to 427	600 to 800	31.8	1-1/4	39A9159X062	39A9155X062	39A9130X062	39A9126X062
			50.8	2	39A9161X062	39A9157X062	39A9132X062	39A9128X062
	371 to 482	700 to 900	31.8	1-1/4	39A9159X072	39A9155X072	39A9130X072	39A9126X072
			50.8	2	39A9161X072	39A9157X072	39A9132X072	39A9128X072
	427 to 538	800 to 1000	31.8	1-1/4	39A9159X082	39A9155X082	29A9130X082	39A9126X082
			50.8	2	39A9161X082	39A9157X082	39A9132X082	39A9128X082
	482 to 593	900 to 1100	31.8	1-1/4	39A9159X092	39A9155X092	39A9130X092	39A9126X092
			50.8	2	39A9161X092	39A9157X092	39A9132X092	39A9128X092
N06600, alloy 6 (CoCr-A) seat and guide	-29 to 232	-20 to 450	31.8	1-1/4	39A9159X102	39A9155X102	39A9130X102	39A9126X102
			50.8	2	39A9161X102	39A1957X102	39A9132X102	39A9128X102
	233 to 427	451 to 800	31.8	1-1/4	39A9159X112	39A9155X112	39A9130X112	39A9126X112
			50.8	2	39A9161X112	39A9157X112	39A9132X112	39A9128X112
	428 to 593	801 to 1100	31.8	1-1/4	39A9159X122	39A9155X122	39A9130X122	39A9126X122
			50.8	2	39A9161X122	39A9157X122	39A9132X122	39A9128X122
17-4 stainless steel, H1150 heat-treated, alloy 6 (CoCr-A) seat and guide	-29 to 427	-20 to 800	31.8	1-1/4	39A9159X132	39A9155X132	39A9130X132	39A9126X132
			50.8	2	39A9161X132	39A9157X132	39A9132X132	39A9128X132
17-4 stainless steel, H1150 DBL heat-treated, alloy 6 (CoCr-A) seat and guide, for sour gas service	-29 to 232	-20 to 450	31.8	1-1/4	39A9200X012	39A9196X012	39A9130X142	39A9126X142
			50.8	2	39A9202X012	39A9198X012	39A9132X142	39A9128X142

Key 3\* Valve Plug for Fisher EHT with Whisper Trim III Cage

VALVE SIZE, NPS	MATERIAL	OPERATING TEMPERATURE LIMITS		VALVE STEM CONNECTION		VALVE RATING			
						CL1500		CL2500	
		°C	°F	mm	Inches	Level A, B, or C	Level D	Level A, B, or C	Level D
8, 10	17-4 stainless steel, H1075 heat-treated	-29 to 232	-20 to 450	31.8	1-1/4	---	39A9123X012	---	39A9138X012
				50.8	2	---	39A9125X012	---	39A9140X012
	316 stainless steel, alloy 6 (CoCr-A) seat and guide	-29 to 149	-20 to 300	31.8	1-1/4	39A9131X012	39A9127X012	39A9146X012	39A9142X012
				50.8	2	39A9133X012	39A9129X012	39A9148X012	39A9144X012
		93 to 204	200 to 400	31.8	1-1/4	39A9131X022	39A9127X022	39A9146X022	39A9142X022
				50.8	2	39A9133X022	39A9129X022	39A9148X022	39A9144X022
		149 to 232	300 to 450	31.8	1-1/4	39A9131X032	39A9127X032	39A9146X032	39A9142X032
				50.8	2	39A9133X032	39A9129X032	39A9148X032	39A9144X032
	N06600, alloy 6 (CoCr-A) seat and guide	-29 to 232	-20 to 450	31.8	1-1/4	39A9131X042	39A9127X042	39A9146X042	39A9142X042
				50.8	2	39A9133X042	39A9129X042	39A9148X042	39A9144X042
	17-4 stainless steel, H1150 heat-treated, alloy 6 (CoCr-A) seat and guide	-29 to 232	-20 to 450	31.8	1-1/4	39A9131X052	39A9127X052	39A9146X052	39A9142X052
				50.8	2	39A9133X052	39A9129X052	39A9148X052	39A9144X052
	17-4 stainless steel, H1150 DBL heat-treated, alloy 6 (CoCr-A) seat and guide, for sour gas service	-29 to 149	-20 to 300	31.8	1-1/4	39A9131X062	39A9127X062	39A9146X062	39A9142X062
				50.8	2	39A9133X062	39A9129X062	39A9148X062	39A9144X062
12, 14	17-4 stainless steel, H900 heat-treated	-29 to 232	-20 to 450	31.8	1-1/4	---	39A9152X012	---	39A9123X012
				50.8	2	---	39A9154X012	---	39A9125X012
	316 stainless steel, alloy 6 (CoCr-A) seat and guide	-29 to 149	-20 to 300	31.8	1-1/4	39A9160X012	39A9156X012	39A9131X012	39A9127X012
				50.8	2	39A9162X012	39A9158X012	39A9133X012	39A9129X012
		93 to 204	200 to 400	31.8	1-1/4	39A9160X022	39A9156X022	39A9131X022	39A9127X022
				50.8	2	39A9162X022	39A9158X022	39A9133X022	39A9129X022
		149 to 232	300 to 450	31.8	1-1/4	39A9160X032	39A9156X032	39A9131X032	39A9127X032
				50.8	2	39A9162X032	39A9158X032	39A9133X032	39A9129X032
	N06600, alloy 6 (CoCr-A) seat and guide	-29 to 232	-20 to 450	31.8	1-1/4	39A9160X042	39A9156X042	39A9131X042	39A9127X042
				50.8	2	39A9162X042	39A9158X042	39A9133X042	39A9129X042
	17-4 stainless steel, H1150 heat-treated, alloy 6 (CoCr-A) seat and guide	-29 to 232	-20 to 450	31.8	1-1/4	39A9160X052	39A9156X052	39A9131X052	39A9127X052
				50.8	2	39A9162X052	39A9158X052	39A9133X052	39A9129X052
	17-4 stainless steel, H1150 DBL heat-treated, alloy 6 (CoCr-A) seat and guide, for sour gas service	-29 to 149	-20 to 300	31.8	1-1/4	39A9201X012	39A9197X012	39A9131X062	39A9127X062
				50.8	2	39A9203X012	39A9199X012	39A9133X062	39A9129X062

\*Recommended spare parts

Key 4\* Valve Plug Stem for NPS 8 or 10 Fisher EHD or EHT Valve without Whisper Trim III Cage

VALVE RATING	VALVE DESIGN	VALVE STEM CONNECTION		ACTUATOR GROUP	TRAVEL		MATERIAL						
		mm	Inches		mm	Inches	17-4 Stainless Steel, H1150 Heat Treated	316 Stainless Steel		S20910			
							Non-coated	Cr Ct	Non-coated	Cr Ct			
CL1500	EHD	31.8	1-1/4	100, 101	76	3	11A3430X632	11A3430X622	15A4075X052	11A3430XG12	---		
				404	89	3.5	11A3430X632	11A3430X622	15A4075X052	11A3430XG12	---		
				405	89	3.5	11A3430X582	11A3430X572	15A4075X032	11A3430XF72	---		
				406	89	3.5	11A3430X562	11A3430X552	15A4075X022	11A3430XF62	---		
				407	89	3.5	11A3430XH62	11A3430X592	15A4075X092	11A3430XF82	---		
		100, 101	76	3	29A5895X122	---	---	29A5895X272	29A6602X062				
	31.8 x 50.8	1-1/4 x 2	404	89	3.5	29A5895X122	---	---	29A5895X272	29A6602X062			
			405	89	3.5	29A5895X092	---	---	29A5895X242	29A6602X032			
			406	89	3.5	29A5895X082	---	---	29A5895X232	29A6602X022			
			407	89	3.5	29A5895X102	---	---	29A5895X252	29A6602X042			
			408	89	3.5	14A1430X442	14A1430X152	15A4076X012	14A1430X342	---			
	50.8	2	409	89	3.5	14A1430X432	14A1430X182	15A4076X022	14A1430X332	---			
EHT			31.8	1-1/4	100, 101	76	3	11A3430X702	11A3430X692	---	11A3430XG62	---	
					404	89	3.5	11A3430X702	11A3430X692	---	11A3430XG62	---	
					405	89	3.5	11A3430X652	11A3430X642	---	11A3430XG22	---	
					406	89	3.5	11A3430X612	11A3430X602	---	11A3430XF92	---	
	407	89			3.5	11A3430XH72	11A3430X662	---	11A3430XG32	---			
31.8 x 50.8	1-1/4 x 2	100, 101	76	3	29A5895X172	---	---	29A5895X432	---				
		404	89	3.5	29A5895X172	---	---	29A5895X432	---				
		405	89	3.5	29A5895X132	---	---	29A5895X282	---				
		406	89	3.5	29A5895X112	---	---	29A5895X262	---				
		407	89	3.5	29A5895X152	---	---	29A5895X412	---				
50.8	2	408	89	3.5	14A1430X452	14A1430X102	---	14A1430X372	---				
		409	89	3.5	14A1430X322	14A1430X192	---	14A1430X362	---				
		CL2500	EHD	31.8	1-1/4	100	64	2.5	11A3430X632	11A3430X622	15A4075X052	11A3430XG12	---
						101	64	2.5	11A3430X612	11A3430X602	15A4075X042	11A3430XF92	---
						100, 101	76	3	11A3430X612	11A3430X602	15A4075X042	11A3430XF92	---
31.8 x 50.8	1-1/4 x 2		100	64	2.5	29A5895X132	---	---	29A5895X282	29A6602X072			
			101	64	2.5	29A5895X112	---	---	29A5895X262	29A6602X052			
			100, 101	76	3	29A5895X112	---	---	29A5895X262	29A6602X052			
EHT	31.8	1-1/4	100	64	2.5	11A3430X702	11A3430X692	---	11A3430XG62	---			
			101	64	2.5	11A3430X682	11A3430X672	---	11A3430XG42	---			
			100, 101	76	3	11A3430X682	11A3430X672	---	11A3430XG42	---			
31.8 x 50.8	1-1/4 x 2	100	64	2.5	29A5895X182	---	---	29A5895X312	---				
		101	64	2.5	29A5895X162	---	---	29A5895X302	---				
		100, 101	76	3	29A5895X162	---	---	29A5895X302	---				

Key 4\* Valve Plug Stem for NPS 12 or 14 Fisher EHD or EHT Valve without Whisper Trim III Cage

VALVE RATING	VALVE DESIGN	VALVE STEM CONNECTION		ACTUATOR GROUP	TRAVEL		MATERIAL				
		mm	Inches		mm	Inches	17-4 Stainless Steel, H1150 Heat Treated	316 Stainless Steel		S20910	
								Non-coated	Cr Ct	Non-coated	Cr Ct
CL1500	EHD and EHT	31.8	1-1/4	404	102	4	11A3430X682	11A3430X672	15A4075X072	---	---
				405, 406	102	4	11A3430XH62	11A3430X592	15A4075X092	---	---
				407	102	4	11A3430X632	11A3430X622	15A4075X052	---	---
				802	114	4.5	11A3430XJ12	11A3430X722	15A4075X192	---	---
				490	114	4.5	11A3430XJ22	11A3430XH22	15A4075X202	---	---
		31.8 x 50.8	1-1/4 x 2	404	102	4	29A5895X162	---	---	29A5895X302	29A6602X092
				405, 406	102	4	29A5895X102	---	---	29A5895X252	29A6602X042
				407	102	4	29A5895X122	---	---	29A5895X272	29A6602X062
				802	114	4.5	29A5895X212	---	---	29A5895X332	29A6602X102
50.8	2	408, 409	102	4	14A1430X462	14A1430X222	15A4076X072	---	---		
		802	114	4.5	14A1430X482	14A1430X122	15A4076X052	---	---		
		490	114	4.5	14A1430X512	14A1430X232	15A4076X082	---	---		
CL2500	EHD	31.8	1-1/4	100, 101	76	3	11A3430XH92	11A3430X712	15A4075X102	---	---
				404	89	3.5	11A3430XH72	11A3430X712	15A4075X102	---	---
				405	89	3.5	11A3430XH92	11A3430X662	15A4075X132	---	---
				406	89	3.5	11A3430X632	11A3430X622	15A4075X052	---	---
				407	89	3.5	11A3430XH82	11A3430X362	15A4075X122	---	---
		31.8 x 50.8	1-1/4 x 2	100, 101	76	3	29A5895X182	---	---	29A5895X312	29A6602X012
				404	89	3.5	29A5895X182	---	---	29A5895X312	29A6602X012
				405	89	3.5	29A5895X142	---	---	29A5895X292	29A6602X082
				406	89	3.5	29A5895X122	---	---	29A5895X272	29A6602X062
	50.8	2	407	89	3.5	29A5895X162	---	---	29A5895X302	29A6602X092	
			408	76	3	14A1430X482	14A1430X122	15A4076X052	---	---	
			408	89	3.5	14A1430X472	14A1430X112	15A4076X062	---	---	
			409	76,89	3, 3.5	14A1430X452	14A1430X102	15A4076X032	---	---	
	EHT	31.8	1-1/4	100, 101	76	3	11A3430XJ12	11A3430X722	---	---	---
				404	89	3.5	11A3430XJ12	11A3430X722	---	---	---
				405	89	3.5	11A3430XH92	11A3430X712	---	---	---
				406	89	3.5	11A3430X702	11A3430X692	---	---	---
407				89	3.5	11A3430X242	11A3430X232	---	---	---	
31.8 x 50.8		1-1/4 x 2	100, 101	76	3	29A5895X212	---	---	29A5895X332	---	
			404	89	3.5	29A5895X212	---	---	29A5895X332	---	
			405	89	3.5	29A5895X192	---	---	29A5895X422	---	
			406	89	3.5	29A5895X172	---	---	29A5895X432	---	
50.8	2	407	89	3.5	29A5895X202	---	---	29A5895X322	---		
		408	76	3	14A1430X502	14A1430X142	---	---	---		
		408	89	3.5	14A1430X492	14A1430X132	---	---	---		
		409	76,89	3, 3.5	14A1430X482	14A1430X122	---	---	---		

Key 4\* Valve Plug Stem for Valve with Whisper Trim III Cage

ACTUATOR GROUP	VALVE SIZE, NPS	VALVE RATING	STEM DIAMETER		TRAVEL		MATERIAL				
			mm	Inches	mm	Inches	17-4PH Stainless Steel, H1150 Heat Treated	316 Stainless Steel		S20910	
								Non-coated	Cr Ct	Non-coated	Cr Ct
802	8, 10	CL1500	31.8	1-1/4	178	7	13A4764X262	13A4764X272	19A9044X012	13A4764X282	---
			31.8 x 50.8	1-1/4 x 2	178	7	29A9092X012	---	---	29A9092X022	29A9093X012
	CL2500	31.8	1-1/4	146	5.75	13A4764X292	13A4764X302	19A9094X022	13A4764X312	---	
		31.8 x 50.8	1-1/4 x 2	146	5.75	29A9092X032	---	---	29A9092X042	29A9093X022	
12, 14	CL1500	31.8	1-1/4	184	7.25	13A4764X322	13A4764X332	13A9094X032	13A4764X342	---	
		31.8 x 50.8	1-1/4 x 2	184	7.25	29A9092X052	---	---	29A9092X062	29A9093X032	
CL2500	31.8	1-1/4	178	7	13A4764X322	13A4764X332	13A9094X032	13A4764X342	---		
	31.8 x 50.8	1-1/4 x 2	178	7	29A9092X052	---	---	29A9092X062	29A9093X032		

Key 6\* Seat Ring and Key 7 Cap Screw for Valve with Gasket Construction and without Whisper Trim III Cage

VALVE SIZE, NPS	MATERIAL		VALVE RATING	KEY 6 SEAT RING	KEY 7 CAP SCREW	
	Seat Ring	Cap Screw			Part Number	Quantity Required
8, 10	17-4PH stainless steel, H1075 heat-treated	SA-564, H1100 heat-treated	CL1500	39A7400X032	19A7492X022	22
			CL2500	39A7402X032	19A7493X022	
	N07718	SB-637, GR 718	CL1500	39A7400X022	19A7492X012	
			CL2500	39A7402X022	19A7493X012	
	316 stainless steel, alloy 6 (CoCr-A) seat	SA-453-660, CLA	CL1500	39A7401X032	19A7492X032	
			CL2500	39A7403X032	19A7493X032	
N06600, alloy 6 (CoCr-A) seat	SB-637, GR 718	CL1500	39A7401X042	19A7492X012		
		CL2500	39A7403X042	19A7493X012		
12, 14	17-4PH stainless steel, H1075 heat-treated	SA-564, H1100 heat-treated	CL1500	39A7404X032	19A7493X022	28
			CL2500	39A7406X032	19A7493X022	
	N07718	SB-637, GR 718	CL1500	39A7404X022	19A7493X012	
			CL2500	39A7406X022	19A7493X012	
	316 stainless steel, alloy 6 (CoCr-A) seat	SA-453-660, CLA	CL1500	39A7405X032	19A7493X032	
			CL2500	39A7407X032	19A7493X032	
N06600, alloy 6 (CoCr-A) seat	SB-637, GR 718	CL1500	39A7405X042	19A7493X012		
		CL2500	39A7407X042	19A7493X012		

Key 6\* Seat Ring and Key 7 Cap Screw for Valve with Gasket Construction and Whisper Trim III Cage

VALVE SIZE, NPS	MATERIAL		VALVE RATING	KEY 6 SEAT RING	KEY 7 CAP SCREW	
	Seat Ring	Cap Screw			Part Number	Quantity Required
8, 10	17-4PH stainless steel, H1075 heat-treated	SA-564, H1100 heat-treated	CL1500	39A7400X032	19A7492X022	22
			CL2500	39A7402X032	19A7493X022	
	17-4PH stainless steel, H1150 heat treated, alloy 6 (CoCr-A) seat	SA-564, H1100 heat-treated	CL1500	39A7401X122	19A7492X022	
			CL2500	39A7403X122	19A7493X022	
	316 stainless steel, alloy 6 (CoCr-A) seat, for temperatures up to 260°C (500°F)	SA-453-660, CLA	CL1500	39A7401X032	19A7492X032	
			CL2500	39A7403X032	19A7493X032	
	316 stainless steel, alloy 6 (CoCr-A) seat, for temperatures up to 427°C (800°F)	SA-453-660, CLA	CL1500	39A7401X062	19A7492X032	
			CL2500	39A7403X062	19A7493X032	
	316 stainless steel, alloy 6 (CoCr-A) seat, for temperatures up to 593°C (1100°F)	SA-453-660, CLA	CL1500	39A7401X082	19A7492X032	
			CL2500	39A7403X082	19A7493X032	
	N06600, alloy 6 (CoCr-A) seat, for temperatures up to 427°C (800°F)	SB-637, GR 718	CL1500	39A7401X042	19A7492X012	
			CL2500	39A7403X042	19A7493X012	
	N06600, alloy 6 (CoCr-A) seat, for temperatures up to 593°C (1100°F)	SB-637, GR 718	CL1500	39A7401X102	19A7492X012	
			CL2500	39A7403X102	19A7493X012	
N07718, heat-treated	SB-637, GR 718	CL1500	39A7400X022	19A7492X012		
		CL2500	39A7402X022	19A7493X012		
12, 14	17-4PH stainless steel, H1075 heat-treated	SA-564, H1100 heat-treated	CL1500	39A9009X022	19A7493X022	28
			CL2500	39A7406X032	19A7493X022	
	17-4PH stainless steel, H1150 heat treated, alloy 6 (CoCr-A) seat	SA-564, H1100 heat-treated	CL1500	39A9010X122	19A7493X022	
			CL2500	39A7407X122	19A7493X022	
	316 stainless steel, alloy 6 (CoCr-A) seat, for temperatures up to 260°C (500°F)	SA-453-660, CLA	CL1500	39A9010X022	19A7493X032	
			CL2500	39A7407X032	19A7493X032	
	316 stainless steel, alloy 6 (CoCr-A) seat, for temperatures up to 427°C (800°F)	SA-453-660, CLA	CL1500	39A9010X042	19A7493X032	
			CL2500	39A7407X062	19A7493X032	
	316 stainless steel, alloy 6 (CoCr-A) seat, for temperatures up to 593°C (1100°F)	SA-453-660, CLA	CL1500	39A9010X062	19A7493X032	
			CL2500	39A7407X082	19A7493X032	
	N06600, alloy 6 (CoCr-A) seat, for temperatures up to 427°C (800°F)	SB-637, GR 718	CL1500	39A9010X082	19A7493X012	
			CL2500	39A7407X042	19A7493X012	
	N06600, alloy 6 (CoCr-A) seat, for temperatures up to 593°C (1100°F)	SB-637, GR 718	CL1500	39A9010X102	19A7493X012	
			CL2500	39A7407X102	19A7493X012	
N07718, heat-treated	SB-637, GR 718	CL1500	39A9009X032	19A7493X012		
		CL2500	39A7406X022	19A7493X012		

\*Recommended spare parts

**Key 6\* Seat Ring and Key 7 Cap Screw for Valve with O-Ring Construction and without Whisper Trim III Cage**

VALVE SIZE, NPS	MATERIAL		VALVE RATING	KEY 6 SEAT RING	KEY 7 CAP SCREW	
	Seat Ring	Cap Screw			Part Number	Quantity Required
8, 10	17-4PH stainless steel, H1075 heat-treated	SA-564, H1100 heat-treated	CL1500	39A9035X022	19A7492X022	10
			CL2500	39A9037X022	19A7493X022	
	316 stainless steel, alloy 6 (CoCr-A) seat	SA-453-660, CLA	CL1500	39A9036X022	19A7492X032	
			CL2500	39A9038X022	19A7493X032	
	N06600, alloy 6 (CoCr-A) seat	SB-637, GR 718	CL1500	39A9036X042	19A7492X012	
			CL2500	39A9038X042	19A7493X012	
	17-4PH stainless steel, H1150 DBL heat-treated for sour gas service	SA-564, H1150 heat-treated	CL1500	39A9035X042	19A7492X042	
			CL2500	39A9037X042	19A7493X042	
	N06600, alloy 6 (CoCr-A) seat, for sour gas service	SB-637, GR 718	CL1500	39A9036X042	19A7492X052	
			CL2500	39A9038X042	19A7493X052	
12, 14	17-4PH stainless steel, H1075 heat-treated	SA-564, H1100 heat-treated	CL1500	39A9039X022	19A7493X022	12
			CL2500	39A9041X022	19A7493X022	
	316 stainless steel, alloy 6 (CoCr-A) seat	SA-453-660, CLA	CL1500	39A9040X022	19A7493X032	
			CL2500	39A9042X022	19A7493X032	
	N06600, alloy 6 (CoCr-A) seat	SB-637, GR 718	CL1500	39A9040X042	19A7493X012	
			CL2500	39A9042X042	19A7493X012	



Key 6\* Seat Ring and Key 7 Cap Screw for Valve with O-Ring Construction and Whisper Trim III Cage

VALVE SIZE, NPS	MATERIAL		VALVE RATING	KEY 6 SEAT RING	KEY 7 CAP SCREW	
	Seat Ring	Cap Screw			Part Number	Quantity Required
8, 10	17-4PH stainless steel, H1075 heat-treated	SA-564, H1150 heat-treated	CL1500	39A9035X022	19A7492X022	10
			CL2500	39A9037X022	19A7493X022	
	17-4PH stainless steel, H1150 heat-treated alloy 6 (CoCr-A) seat	SA-564, H1100 heat-treated	CL1500	39A9036X062	19A7492X022	
			CL2500	39A9038X062	19A7493X022	
	N06600, alloy 6 (CoCr-A) seat	SB-637, GR 718	CL1500	39A9036X042	19A7492X012	
			CL2500	39A9038X042	19A7493X012	
	316 stainless steel, alloy 6 (CoCr-A) seat	SA-453-660, CLA	CL1500	39A9036X022	19A7492X032	
			CL2500	39A9038X022	19A7493X032	
	17-4PH stainless steel, H1150 DBL heat-treated, for sour gas service	SA-564, H1150 heat-treated	CL1500	39A9035X042	19A7492X042	
			CL2500	39A9037X042	19A7493X042	
	17-4PH stainless steel, H1150 DBL heat-treated, alloy 6 (CoCr-A) seat, for sour gas service	SA-564, H1150 heat-treated	CL1500	39A9036X072	19A7492X042	
			CL2500	39A9038X072	19A7493X042	
	N06600, alloy 6 (CoCr-A) seat, for sour gas service	SB-637, GR 718	CL1500	39A9036X042	19A7492X052	
			CL2500	39A9038X042	19A7493X052	
12, 14	17-4PH stainless steel, H1075 heat-treated	SA-564, H1150 heat-treated	CL1500	39A9011X022	19A7493X022	12
			CL2500	39A9041X022	19A7493X022	
	17-4PH stainless steel, H1150 heat-treated alloy 6 (CoCr-A) seat	SA-564, H1100 heat-treated	CL1500	39A9012X062	19A7493X022	
			CL2500	39A9042X062	19A7493X022	
	N06600, alloy 6 (CoCr-A) seat	SB-637, GR 718	CL1500	39A9012X042	19A7493X012	
			CL2500	39A9042X042	19A7493X012	
	316 stainless steel, alloy 6 (CoCr-A) seat	SA-453-660, CLA	CL1500	39A9012X022	19A7493X032	
			CL2500	39A9042X022	19A7493X032	
	17-4PH stainless steel, H1150 DBL heat-treated, for sour gas service	SA-564, H1150 heat-treated	CL1500	39A9011X042	19A7493X042	
			CL2500	39A9041X042	19A7493X042	
	17-4PH stainless steel, H1150 DBL heat-treated, alloy 6 (CoCr-A) seat, for sour gas service	SA-564, H1150 heat-treated	CL1500	39A9012X072	19A7493X042	
			CL2500	39A9042X072	19A7493X042	
	N06600, alloy 6 (CoCr-A) seat, for sour gas service	SB-637, GR 718	CL1500	39A9012X042	19A7493X052	
			CL2500	39A9042X042	19A7493X052	

\*Recommended spare parts

**Actuator Groups by Type Number**

<b>Group 100</b> 127 mm (5-Inch) Yoke Boss	<b>Group 406</b> 127 mm (5-Inch) Yoke Boss
472 473 474 476 585C 657 1008	667 MO 667-4 MO
	<b>Group 407</b> 127 mm (5-Inch) Yoke Boss
	474 585C 657
	<b>Group 408</b> 127 mm (5H) and 178 mm (7-Inch) Yoke Boss
	657 Size 100 1008
<b>Group 101</b> 127 mm (5-Inch) Yoke Boss	<b>Group 409</b> 127 mm (5H) and 178 mm (7-Inch) Yoke Boss
667	667 Size 100
<b>Group 404</b> 127 mm (5-Inch) Yoke Boss	<b>Group 802</b> 127 mm (5-Inch) Yoke Boss
667 667-4	585C
<b>Group 405</b> 127 mm (5-Inch) Yoke Boss	
657 MO 657-4 MO	



**Neither Emerson, Emerson Process Management, nor any of their affiliated entities assumes responsibility for the selection, use or maintenance of any product. Responsibility for proper selection, use, and maintenance of any product remains solely with the purchaser and end user.**

Fisher, Whisper Trim, Cavitrol, and ENVIRO-SEAL are marks owned by one of the companies in the Emerson Process Management business unit of Emerson Electric Co. Emerson Process Management, Emerson, and the Emerson logo are trademarks and service marks of Emerson Electric Co. All other marks are the property of their respective owners.

The contents of this publication are presented for informational purposes only, and while every effort has been made to ensure their accuracy, they are not to be construed as warranties or guarantees, express or implied, regarding the products or services described herein or their use or applicability. All sales are governed by our terms and conditions, which are available upon request. We reserve the right to modify or improve the designs or specifications of such products at any time without notice.

**Emerson Process Management**

Marshalltown, Iowa 50158 USA

Sorocaba, 18087 Brazil

Chatham, Kent ME4 4QZ UK

Dubai, United Arab Emirates

Singapore 128461 Singapore

[www.Fisher.com](http://www.Fisher.com)

