

POSI-SEAL® Type A31A Cryogenic High Performance Butterfly Valve

Contents

Introduction	1
Scope of Manual	1
Specifications	2
Description	2
Installation	2
Adjusting the Actuator Travel Stops or Travel ..	3
Valve Orientation	3
Preparing for Installation	4
Installing Wafer-Style Valves	5
Installing Single-Flange Valves	6
Maintenance	7
Replacing Packing	7
Removing the Valve from the Pipeline	8
Removing/Installing the Seal Ring	8
NOVEX™ Seal Installation	9
Kel-F and Kel-F/aluminum Seal Installation ..	10
Anti-Blowout Protection, Packing, Valve Shaft(s), Disc, and Bearing Maintenance	12
Disassembly	13
Installing a One-Piece Shaft	14
Installing a Two-Piece Shaft	15
Installing the Gasket Retainer	16
Parts Ordering	17
Parts List	17



Figure 1. Type A31A Cryogenic Valve with Type 1035 Actuator

No person may install, operate, or maintain a Type A31A Cryogenic valve without first • being fully trained and qualified in valve, actuator, and accessory installation, operation, and maintenance, and • carefully reading and understanding the contents of this manual. If you have any questions about these instructions, contact your Fisher sales office before proceeding.

Note

Neither Emerson, Emerson Process Management, nor Fisher assume responsibility for the selection, use, or maintenance of any product. Responsibility for proper selection, use, and maintenance of any Fisher product remains solely with the purchaser and end-user.

Introduction

Scope of Manual

This instruction manual provides installation, maintenance, and parts ordering information for the POSI-SEAL® Type A31A Cryogenic high-performance butterfly valves (see figure 1). The Series C (3- through 6-inch Class 150 & 300 and 8-inch Class 150) feature a cast one-piece extension. The 8-inch Class 300, and 10- through 24-inch Class 150 & 300 designs have a two-piece extension. For information regarding actuators and accessories, refer to separate instruction manuals.



Cryogenic-Rotary Valve

Table 1. Specifications

<p>Available Valve Configurations</p> <ul style="list-style-type: none"> ■ Flangeless, wafer-style or ■ single-flange (lugged) control valve with a one-piece extension housing and either NOVEX seal (standard), Kel-F seal (optional) or Kel-F seal with Aluminum backup V-ring (optional) <p>Valve Sizes</p> <ul style="list-style-type: none"> ■ 3, ■ 4, ■ 6, ■ 8, ■ 10, ■ 12, ■ 14, ■ 16, ■ 18, ■ 20, or ■ 24-inch <p>End Connection Style</p> <ul style="list-style-type: none"> ■ Flangeless, wafer-style or ■ single flange valve body designed to fit between raised-face mating flanges per ASME B16.5 Class 150 or 300 <p>Maximum Inlet Pressure/Temperature⁽¹⁾</p> <p>Consistent with ANSI Class ■ 150 and ■ 300 pressure/temperature ratings per ASME B16.34, except that 38°C (100°F) rating is applicable to -254°C (-425°F). NOVEX seal maximum</p>	<p>pressure/temperature rating is the same as the valve body. See figure 2 for rating of Kel-F seal.</p> <p>Valve Classification</p> <p>Face-to-face dimensions are in compliance with MSS SP68 and API 609 standards; valve bodies are designed for installation between ASME B16.5 Class 150 or 300 raised-face flanges</p> <p>Materials of Construction</p> <p>See Bulletin 21.1:Cryogenic-Rotary</p> <p>Installed Valve Orientation</p> <p>See figure 3 for orientation guidelines</p> <p>Available Actuators</p> <ul style="list-style-type: none"> ■ Type 1035, ■ Bettis Pneumatic or ■ Type 1051/1052 <p>Disc Rotation</p> <p>Clockwise to close</p>
---	---

1. The pressure/temperature limits in this manual, and any applicable code or standard limitation, should not be exceeded.

Description

The Type A31A Cryogenic Series C (3- through 6-inch Class 150 & 300 and 8-inch Class 150) High Performance Butterfly Valve features either a double D drive shaft to allow direct coupling to the Type 1035 actuator or keyed shaft (optional). The Type A31A Cryogenic is a reliable, high-performance butterfly valve for cryogenic applications.

The Type A31A Cryogenic is available in either a flangeless (wafer) or a single-flange (lugged) valve body style and a variety of seals.

The standard seal for the Type A31A Cryogenic valve is the NOVEX™ metal seal which provides tight shutoff, low operating torques and the ruggedness required for cryogenic service. Kel-f and Kel-f/aluminum seals are also available.

Installation

WARNING

Always wear protective gloves, clothing and eyewear when performing any installation operations to avoid injury.

To avoid personal injury or property damage resulting from the sudden release of pressure, do not install the valve assembly where service conditions could exceed the limits given in this manual or on appropriate nameplates. Use pressure-relieving devices as required by government or accepted industry codes and good engineering practices.

Check with your process or safety engineer for any additional measures that must be taken to protect against process media.

If installing into an existing application, also refer to the WARNING

at the beginning of the Maintenance section in this instruction manual.

CAUTION

Responsibility for the safety of process media and compatibility of valve materials rests solely with the purchaser and end-user. When ordered, the valve configuration and construction materials were selected to meet particular pressure, pressure drop, temperature, and controlled fluid conditions. Because pressure drop and temperature range capabilities limit some combinations of materials, do not apply any other conditions to the valves without first contacting your Fisher sales office.

Before installation check the maximum allowable inlet pressures for Type A31A Cryogenic valves shown in figure 2 and the Specifications table.

Adjusting the Actuator Travel Stops



WARNING

The edges of a rotating valve disc have a shearing effect that may result in personal injury. To avoid personal injury, keep clear of the disc edges when rotating the disc.

CAUTION

When using an actuator, the actuator travel stops or the actuator travel (for actuators without adjustable stops) must be adjusted so that the disc stop in the valve body does not absorb the output of the actuator. Failure to limit actuator travel as described in the next step can result in damage to the valve shaft or other valve parts.

1. Locate the actuator travel stop that establishes the closed position of the valve disc. When adjusting the travel stop or travel, make sure that the disc is

from 0.03 to 0.76 mm (0.001 to 0.030 inch) away from the internal stop in the valve body. This adjustment is necessary to be certain that the actuator output torque is fully absorbed by the actuator travel stop or by the actuator. The internal travel stop in the valve body should not absorb any of the actuator torque.

2. Before installing the valve/actuator assembly in the process line, cycle the valve several times to be sure the valve disc returns to the proper position.

Valve Orientation

Note

When the process flow is gas, install the valve with the shaft in the horizontal position.

When the process flow is liquid the valve should be installed at an incline above horizontal of at least 20 degrees, as shown in figure 3. Inclined installation can enhance valve performance by preventing direct cryogenic liquid contact with the packing.

The Type A31A Cryogenic valve is designed for installation with the shaft(s) in any orientation around the pipeline: horizontal, vertical, or at an intermediate angle. However, when installing the valve in cryogenic service, follow the recommendations below, which are based on application experience:

- Installing the valve with the extension housing or bonnet four to six inches beyond the cold box (see figure 3) provides space for slight boil-off of cryogenic liquids.
- When installed with the extension stem inclined 20 degrees above horizontal, the vapor pocket resulting from cryogenic liquid boil-off prevents the colder liquid from contacting the stem packing area.
- Recommended installation for optimum seal performance of the NOVEX and Kel-F seals is reverse flow (into the back of the disc).
- A flow tag with an arrow is provided for proper installation.

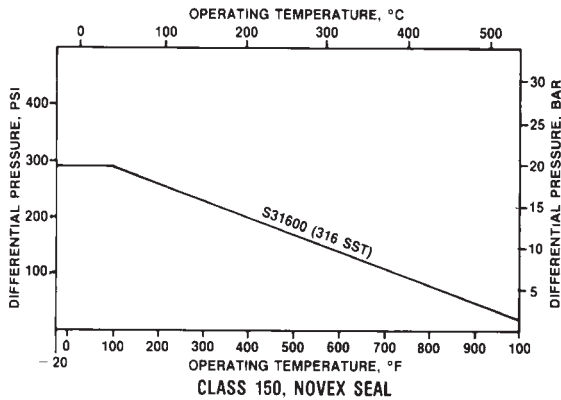

C0759-1/IL

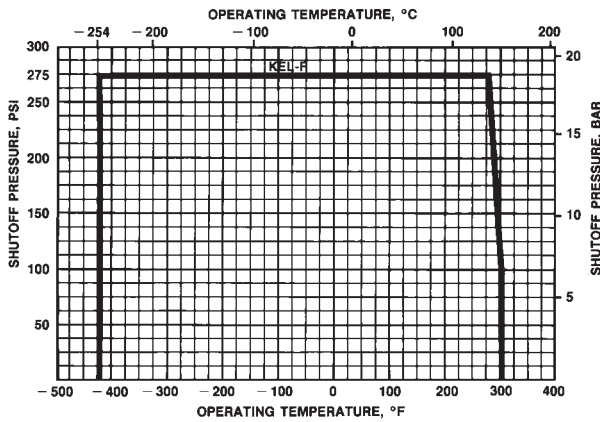
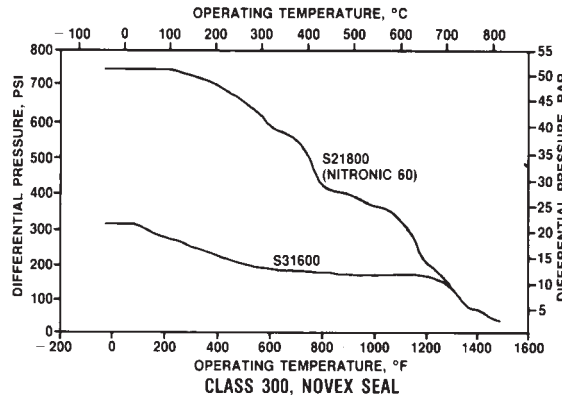

A4132-1/IL

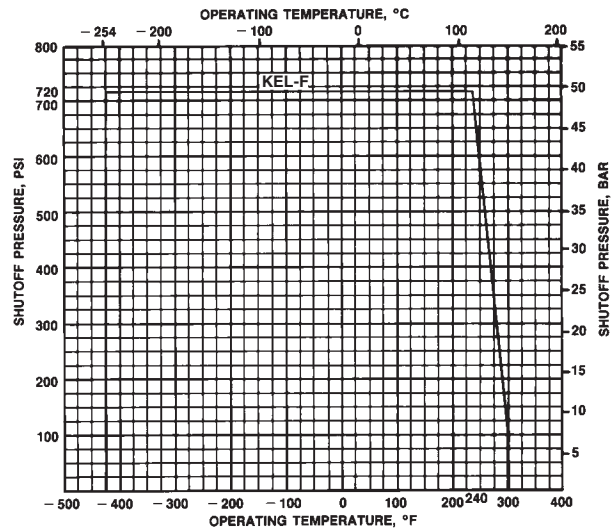

A3715-2/IL

Figure 2. Maximum Pressure/Temperature Ratings

Preparing for Installation

CAUTION

To avoid damage to the valve disc during installation, the valve must be in the fully-closed position. If the Type A31A Cryogenic valve is equipped with a fail-open actuator, remove the actuator before installing the valve/actuator assembly or cycle the valve into the fully closed position. Then, take appropriate steps to ensure that the actuator does not cause the valve to open during installation.

1. The Type A31A Cryogenic valve is normally shipped as part of an assembly with an actuator and other accessories. If the valve and actuator have been purchased separately or if the actuator has been removed for maintenance, properly mount the actuator and adjust valve/actuator travel and all travel stops before inserting the valve into the line.

Follow the instructions in this manual for Adjusting Travel stops. Also, refer to a separate actuator instruction manual for detailed actuator mounting and adjustment procedures.

2. If not previously removed, remove the protective end covers from the valve and inspect the valve body to be certain that it is free of foreign material. Also, be certain that adjacent pipelines are free of any foreign material, such as pipe scale or welding slag that could damage the valve seating surfaces.

Table 2. Valve Body Data, Class 150

VALVE SIZE, INCHES	SHAFT DIAMETER AT YOKE BEARING	FACE-TO-FACE DIMENSION ⁽¹⁾	MINIMUM I.D. ⁽²⁾	APPROXIMATE WEIGHT	
				Wafer	Single Flange
				Kilograms	
mm					
3	16	47.6	71.4	12	16
4	19	54.0	93.7	21	22
6	25	57.2	147.6	24	28
8	25	63.5	196.9	34	40
10	32	71.4	254.0	57	67
12	38	81.0	298.5	74	93
14	30	92	330	87	120
16	32	102	378	133	182
18	38	114	429	170	231
20	44	127	470	210	302
24	57	154	575	326	455
Inches					
Pounds					
3	5/8	1-7/8	2.81	27	36
4	3/4	2-1/8	3.69	46	48
6	1	2-1/4	5.81	53	61
8	1	2-1/2	7.75	75	89
10	1-1/4	2-13/16	10.00	125	148
12	1-1/2	3-3/16	11.75	164	206
14	1-3/16	3-5/8	13	191	265
16	1-1/4	4	14-7/8	294	401
18	1-1/2	4-1/2	16-7/8	374	510
20	1-3/4	5	18-1/2	463	665
24	2-1/4	6-1/16	22-5/8	719	1004

1. Face-to-face dimensions are in compliance with MSS SP68 and API 609 specifications.
2. Minimum I.D. is the minimum pipe or flange I.D. required for disc swing clearance.

Table 3. Valve Body Data, Class 300

VALVE SIZE, INCHES	SHAFT DIAMETER AT YOKE BEARING	FACE-TO-FACE DIMENSION ⁽¹⁾	MINIMUM I.D. ⁽²⁾	APPROXIMATE WEIGHT	
				Wafer	Single Flange
				Kilograms	
mm					
3	16	47.6	71.4	12	16
4	19	54.0	93.7	21	24
6	25	57.2	146.1	24	28
8	32	73.0	186.2	47	52
10	38	85.3	230.1	80	100
12	44	94.1	281.7	103	135
14	44	117	305	142	249
16	44	133	349	213	325
18	57	149	391	259	434
20	70	159	442	401	582
24	70	181	523	512	863
Inches					
Pounds					
3	5/8	1-7/8	2.82	27	35
4	3/4	2-1/8	3.69	46	52
6	1	2-1/4	5.75	53	61
8	1-1/4	2-7/8	7.32	104	115
10	1-1/2	3-23/64	9.06	176	220
12	1-3/4	3-45/64	11.09	227	298
14	1-3/4	4-5/8	12	314	548
16	1-3/4	5-1/4	13-3/4	470	716
18	2-1/4	5-7/8	15-3/8	570	956
20	2-3/4	6-1/4	17-13/32	884	1282
24	2-3/4	7-1/8	20-19/32	1128	1903

1. Face-to-face dimensions are in compliance with MSS SP68 and API 609 specifications.
2. Minimum I.D. is the minimum pipe or flange I.D. required for disc swing clearance.

CAUTION

The Type A31A Cryogenic valve is designed for use with the appropriate piping schedule for the specified ANSI class. Minimum inside diameters for flanges or pipe mating with valves are shown in tables 2 and 3. Be certain to align the valve accurately to avoid contact between the disc and the flanges. Improper alignment or insufficient space for disc rotation could result in damage to the disc.

Additionally, be certain that the valve body and any adjacent pipelines are free of foreign material, such as pipe scale or welding slag that could damage the valve seating surfaces.

3. Select the appropriate gaskets for the application. Flat sheet, spiral wound, or other gasket types, made to ANSI B16.5 group or user's standard, can be used on the valves depending on the service conditions of the application.
4. Refer to table 4 for the quantity and size of flange bolts required.

Installing Wafer-Style Valves

WARNING

The edges of a rotating valve disc have a shearing effect that may result in personal injury. To avoid personal injury, keep clear of the disc edges when rotating the disc.

1. See figure 3 for recommended valve orientation. See table 4 for flange bolt specifications. Install the lower flange bolts first to form a cradle for the valve.

Cryogenic-Rotary Valve

Table 4. Hex Head Screw, Stud Bolt and Cap Screw Data⁽¹⁾

VALVE SIZE, INCH	NUMBER		SIZE DIA. INCH & THREAD		LENGTH, INCH	
	Class 150	Class 300	Class 150	Class 300	Class 150	Class 300
Wafer Style with Stud Bolts						
3	4	8	5/8-11	3/4-10	5-3/4	6
4	8	8	5/8-11	3/4-10	6	6-1/2
6	8	12	3/4-10	3/4-10	6-1/2	7-1/2
8	8	12	3/4-10	7/8-9	7	9
10	12	16	7/8-9	1-8	8	10
12	12	16	7/8-9	1-1/8-8	8-1/2	11
14	12	16	1-8	1-1/8-8	9-1/2	12
16	16	16	1-8	1-1/4-8	10	13-1/2
18	16	20	1-1/8-8	1-1/4-8	11	13-3/4
20	20	20	1-1/8-8	1-1/4-8	12	14-1/2
24	20	20	1-1/4-8	1-1/2-8	14	16-1/2
Wafer Style with Cap Screws						
14	---	8	---	1-1/8-8	---	3-1/2
16	---	8	---	1-1/4-8	---	3-3/4
18	---	8	---	1-1/4-8	---	4
20	---	8	---	1-1/4-8	---	4
24	---	8	---	1-1/2-8	---	4-1/2
Single Flange Style with Cap Screws						
3	8	16	5/8-11	3/4-10	1-7/8	2
4	16	16	5/8-11	3/4-10	2	2-1/4
6	16	24	3/4-10	3/4-10	2	2-1/2
8	16	24	3/4-10	7/8-9	2-1/4	3
10	24	32	7/8-9	1-8	2-1/2	3
12	24	32	7/8-9	1-1/8-8	2-3/4	3-3/8
14	24	40	1-8	1-1/8-8	2-3/4	3-1/2
16	32	40	1-8	1-1/4-8	3	3-3/4
18	32	48	1-1/8-8	1-1/4-8	3-1/4	4
20	40	48	1-1/8-8	1-1/4-8	3-1/2	4
24	40	48	1-1/4-8	1-1/2-8	3-1/2	4-1/2

1. Thread engagement in accordance with ANSI B31.3 "Chemical Plant and Petroleum Refinery Piping".

2. Properly orient the valve according to the specific application. For optimum performance, install the valve so that the shaft will be on the high pressure side of the valve at shutoff (reverse flow). Install the valve and the gaskets between the flanges into the cradle formed by the flange bolts.

3. Install the remaining flange bolts, making sure to center the gaskets on the gasket sealing surfaces of the flange and valve body.

4. Tighten the flange bolts in an alternating criss-cross fashion to a torque value of one-fourth of the final bolting torque. Repeat this procedure several times increasing the torque value each time by a fourth of the final desired torque. When the final torque value has been applied, tighten each flange bolt again to allow for gasket compression.

Note

The optional graphite ribbon packing and metal bearings are composed of all conductive material to electrically bond the shaft to the valve for hazardous area service, as opposed to the non-conductive PTFE packing and bearings.

5. For more information, refer to the Packing Maintenance section below.

Installing Single-Flange Valves



WARNING

The edges of a rotating valve disc have a shearing effect that may result in personal injury. To avoid personal injury, keep clear of the disc edges when rotating the disc.

1. See figure 3 for recommended valve orientation. See table 4 for hex head cap screw specifications.
2. Properly orient the valve according to the specific application. For optimum shutoff, install the valve for reverse flow.
3. Position the valve between the flanges. Be sure to leave enough room for the flange gaskets. Install the lower flange bolts.
4. Select the appropriate gaskets for the application. Flat sheet, spiral wound, or other gasket types, made to the ANSI B16.5 group standard or user's standard, can be used on the valve depending on the service conditions of the application. Install the gaskets and align the valve and the gaskets.
5. Install the remaining bolts.
6. Tighten the flange bolts in an alternating criss-cross fashion to a torque value of one-fourth of the final bolting torque. Repeat this procedure several times increasing the torque value each time by a fourth of the final desired torque. When you get to the final torque value, tighten each flange bolt again to allow for gasket compression.

Note

The optional graphite ribbon packing and metal bearings are composed of all conductive material to electrically bond the shaft to the valve for hazardous area service, as opposed to the non-conductive PTFE packing and bearings.

Maintenance

Valve parts are subject to normal wear and must be inspected and replaced as necessary. The frequency of inspection and replacement depends upon the severity of service conditions.



WARNING

Avoid personal injury from sudden release of process pressure. Before performing any maintenance operations:

- Always wear protective gloves, clothing and eyewear when performing any maintenance operations to avoid personal injury.
- Disconnect any operating lines providing air pressure, electric power, or a control signal to the actuator. Be sure the actuator cannot suddenly open or close the valve.
- Use bypass valves or completely shut off the process to isolate the valve from process pressure. Relieve process pressure on both sides of the valve. Drain the process media from either side of the valve.
- Vent the power actuator loading pressure and relieve any actuator spring precompression.
- Use lock-out procedures to be sure that the above measures stay in effect while you work on the equipment.
- The valve packing box may contain process fluids that are pressurized *even when the valve has been removed from the pipeline*. Process fluids may spray out under pressure when removing the packing hardware or packing rings, or when loosening the packing box pipe plug.
- Check with your process or safety engineer for any additional measures that must be taken to protect against process media.

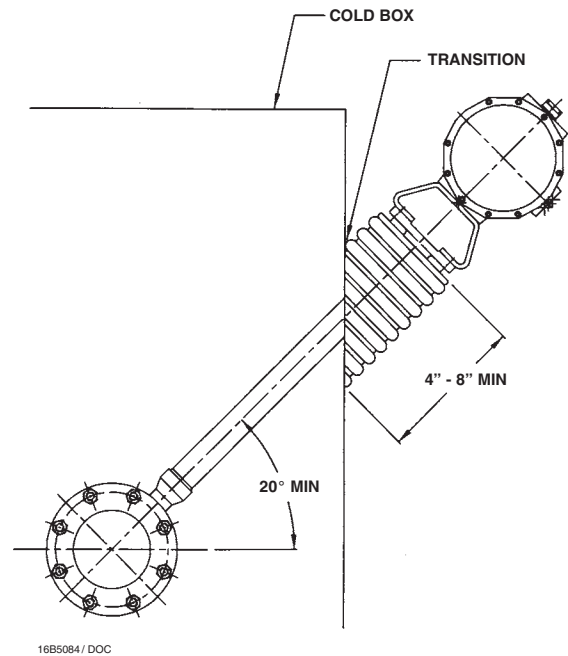

Figure 3. Properly Installed Cryogenic Valve

Replacing Packing

The Type A31A Cryogenic valve is designed so the packing can be replaced without removing the valve from the process pipeline, provided there is no internal pressure. Packing may be PTFE V-rings or graphite.

Key numbers for the parts in this section may be found in figures 7 and 8.

CAUTION

Tighten the packing flange only enough to prevent shaft leakage. Excessive tightening will only accelerate wear of the packing and could produce higher torques on the valve than expected.

Usually, packing leakage can be eliminated by merely tightening the hex nuts (key 15) located above the packing flange while the valve is in the pipeline. However, if leakage continues, replace the packing.

Cryogenic-Rotary Valve

CAUTION

Never use a wrench or pliers on the valve shaft. A damaged shaft could cut the packing and allow leakage.

1. Before loosening any parts, isolate the valve from the line pressure, release pressure from both sides of the valve body, and drain the process media from both sides of the valve.
2. Then, remove the hex nuts (key 18) and lift off the packing follower (key 11). The packing (key 13) is now accessible. Refer to figure 6 for details of the blowout protection.
3. Use a packing extractor to remove the packing. Insert the corkscrew-like end of the tool into the first piece of packing and pull firmly to remove the packing. Repeat this process until all packing has been removed.

Note

For valves equipped with non-metallic (PTFE composition) bearings, perform the following step to inspect and/or replace the outboard bearing (key 10).

4. Using a formed hook or probe, carefully remove the packing ring (key 12) and inspect the outboard bearing (key 10) for excessive intrusion or wear. Outboard bearings are only found on the 3- through 12-inch sizes. If necessary, remove the bearing carefully using needle-nose pliers and install a new bearing and existing packing ring using the packing follower (key 11) as a driver.

CAUTION

Be careful when cleaning the packing box. Scratches to the shaft or inside diameter of packing bore might cause leakage.

5. Before installing new packing, clean the packing box.
6. Install new packing (key 13) one ring at a time, using the packing follower (key 11) as a driver. If using split-ring packing, stagger the splits in the rings to avoid creating a leak path.
7. Reinstall all parts. Tighten the packing follower nuts (key 18) as needed to stop leakage under operating conditions.

Removing the Valve from the Pipeline

1. Disconnect any operating lines providing air pressure, electric power, or a control signal to the actuator. Be sure the actuator cannot suddenly open the valve. Vent the power actuator loading pressure.
2. Use bypass valves or completely shut off the process to isolate the valve from process pressure. Relieve process pressure on both sides of the valve. Drain the process media from either side of the valve.

CAUTION

Damage to the valve disc, piping or pipe flanges can occur if the disc is not closed when the valve is being removed from the pipeline. If necessary, stroke the actuator to place the disc in the closed position while removing the valve from the pipeline.

3. Loosen the flange bolting that holds the valve. Make sure the valve cannot slip or twist while loosening and removing the bolting.
4. Make certain the valve disc is closed and remove the valve from the pipeline. Support the valve properly and move the valve to an appropriate work area.

Removing/Installing the Seal Ring

Unless otherwise indicated, key numbers and part names are listed in figures 7 and 8.

Note

For valves large enough to be safely placed on a flat surface without tipping, it is possible to replace the seal ring (key 7) while the actuator is mounted to the valve and can be accomplished by cycling the valve to 90 degrees open.

1. After removing the valve from the pipeline, remove the manual or power actuator. Manually rotate the drive shaft (key 4) counterclockwise until the disc has moved a full 180 degrees away from the closed position.
2. Lay the valve flat on a work bench in a secure position with the retaining ring (key 2) and retaining ring screws (key 19) facing up. Properly secure the valve on a suitable worktable so it can not slip, twist, or fall during maintenance. Remove all retaining ring screws.

3. Remove the retaining ring by placing a socket head retaining ring screw from the retaining ring in each of the two retaining ring jacking screw holes. Slowly turn the screws until the retaining ring has been lifted from the valve body. Remove the retaining ring to expose the seal ring in the T-slot area of the valve body.

Note

The Type A31A Cryogenic valve is available with different seal designs and components. See figure 4 to identify the specific seal design.

CAUTION

To avoid possible leakage, be careful not to damage the gasket sealing surface, the seal ring, or the T-slot area in the valve body while performing the next two steps.

4. Remove and discard the retaining ring gasket (key 16). Be careful to not scratch the gasket seating surface.

5. Insert a regular screw driver or other similar tool under the top edge of the seal ring (key 7), and gently pry it out of the T-slot area in the valve body. Take care not to damage the seal ring or T-slot area of the valve body. After the seal ring has been removed, clean the T-slot area, retaining ring, and, if required, polish the disc thoroughly with fine steel wool or other appropriate material.

NOVEX™ Seal Installation

Unless otherwise indicated, key numbers and part names are listed in figures 7 and 8. Seal installation is shown in figure 5.

A maintenance kit with installation tools is available through your Fisher sales office.

1. Locate the replacement seal ring (key 7) and note the shape of the ring. The ring is wider across one edge diameter and narrower across the other edge diameter. Also, note the wide groove around the outside circumference.

Before installing the seal ring into the valve body, place the backup ring, if applicable, (key 8) into the wide, outer groove of the seal ring.

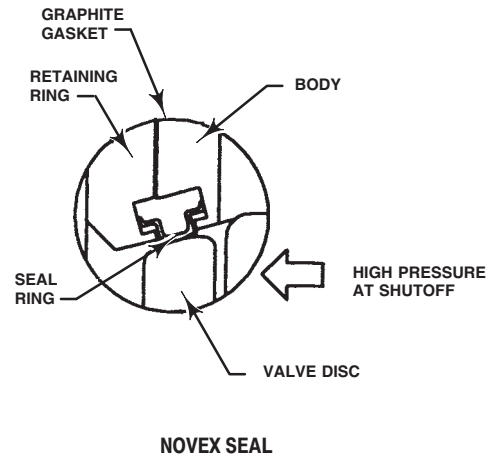

NOVEX SEAL

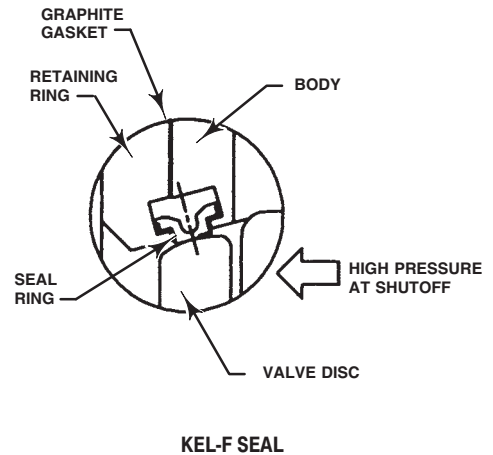

KEL-F SEAL

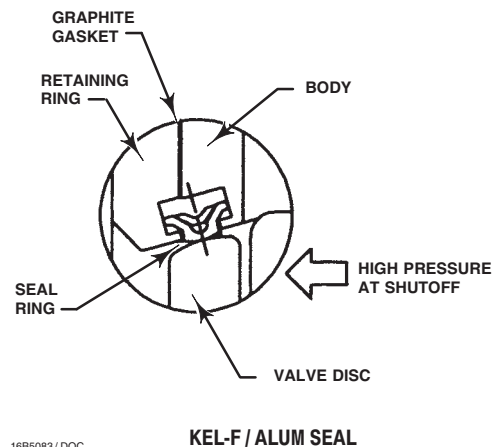

KEL-F / ALUM SEAL

16B5083 / DOC

Figure 4. Available Seal Configurations

Cryogenic-Rotary Valve

2. Install the seal ring and backup ring assembly in the valve body. The wider outside diameter of the seal ring goes into the T-slot area of the valve body as shown in figure 5. Start the edge with the wider diameter into the T-slot of the valve body.

CAUTION

Use extreme care to avoid damaging the gasket while punching one initial screw hole through the gasket for alignment in the following step.

3. Once the seal ring and backup ring have been fully installed into the valve body T-slot, the retaining ring gasket can be installed. This gasket is a thin graphite material. Use extreme care to avoid damaging the gasket while punching one initial screw hole through the gasket for alignment.

4. Install the retaining ring, and align the screw holes in the retaining ring with the holes in the valve body. Install the first retaining ring screw through the punched hole in the retaining ring gasket. Install the other retaining ring screws by pushing them through the graphite gasket and threading them into the valve body.

5. Tighten the retaining ring screws just enough to eliminate any movement of the retaining ring. Do not over-tighten the retaining ring screws.



WARNING

Avoid personal injury or property damage caused by the impact of a falling or tipping valve. Support large valves during maintenance.

6. To complete this step, stand the valve up. Support the valve securely using methods appropriate for the valve size. If a vise or other clamps are being used, make certain the flange gasket sealing area of the valve body is not damaged.

7. Manually rotate the drive shaft (key 4) to turn the disc clockwise to meet the seal ring.

8. Place a piece of rubber, or other soft material, between the disc and internal travel stop to protect the disc. With a rubber mallet, tap the disc until it contacts the internal travel stop. When the disc makes contact with the stop, manually rotate the disc counterclockwise back out of the seal ring to a 90-degree open position.

9. The final seating of the retaining ring screws can now be done. For the screw torque values, refer to table 5.

10. Repeat steps 8 and 9 two more times.

Note

When attaching the actuator to the valve, make sure the valve disc is not in contact with the internal travel stop. The valve disc should be positioned from 0.03 to 0.76 mm (0.001 to 0.030 inch) away from the internal stop in the valve body.

CAUTION

When using an actuator, the actuator travel stops or the actuator travel (for actuators without adjustable stops) must be adjusted so that the disc stop in the valve body does not absorb the output of the actuator. Failure to limit actuator travel as described in the next step can result in damage to the valve shaft or other valve parts.

11. Use an appropriate tool (such as a feeler gauge) and position the disc from 0.03 to 0.76 mm (0.001 to 0.030 inch) away from the internal stop in the valve body.

This adjustment is necessary to be certain that the actuator output torque is fully absorbed by the actuator travel stop or by the actuator. The internal travel stop in the valve body should not absorb any of the actuator torque.

Kel-F and Kel-F/Aluminum Seal Installation

Unless otherwise indicated, key numbers and part names are listed in figures 7 and 8.

A maintenance kit with installation tools is available through your Fisher sales office.

1. Locate the replacement seal ring (key 7) and note the shape of the ring. The ring is wider across one edge diameter and narrower across the other edge diameter. Also, note the wide groove around the outside circumference. If an aluminum backup ring (key 8) is provided, fit this over the back of the seal ring (matching seal and backup ring angles) prior to installation in the valve.

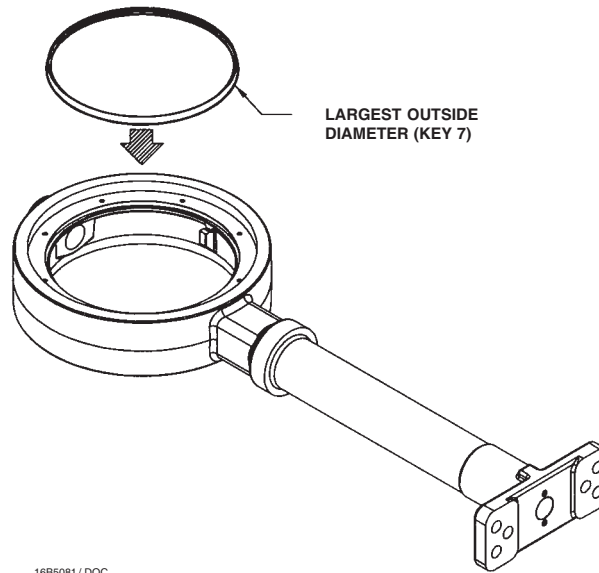

16B5081 / DOC

Figure 5. Typical Seal Installation

Table 5. Torque Values for Fasteners

FASTENER NOMINAL SIZE	RETAINING RING SCREWS		GASKET RETAINING BOLTS	
	N•m	In•lbs	N•m	In•lbs
#10	4.6	41	4.0	35
1/4	11	100	9.2	81
5/16	25	220	19	167
3/8	45	400	33	295
	N•m	ft•lbs	N•m	ft•lbs
7/16	72	53	53	39
1/2	112	83	80	59
9/16	161	119	117	86
5/8	225	166	161	119
3/4	401	296	286	210
7/8	651	480	447	330
1	976	720	651	480
1-1/8	1356	1000	837	617

Note: These values are based upon standard materials, S66286/Inconel screws and ASTM A193GRB6 bolts. For other special fastener materials, please contact your Fisher sales office.

2. Install the seal ring, and if applicable back-up ring, in the valve body by first placing the wider outside diameter of the seal ring into the T-slot area of the valve body as shown in figure 5.

3. Once the seal ring has been fully installed into the valve body T-slot, the retaining ring gasket can be installed. This gasket is a thin graphite material. Use extreme care to avoid damaging the gasket while punching one initial screw hole through the gasket for alignment.

4. Install the retaining ring, and align the screw holes in the retaining ring with the holes in the valve body. Install the first retaining ring screw through the punched hole in the retaining ring gasket. Install the other retaining ring screws by pushing them through

the graphite gasket and threading them into the valve body.

5. Tighten the retaining ring screws just enough to eliminate any movement of the retaining ring. Do not over-tighten the retaining ring screws.

WARNING

Avoid personal injury or property damage caused by the impact of a falling or tipping valve. Support large valves during maintenance.

6. To complete this step, stand the valve up. Support the valve securely using methods

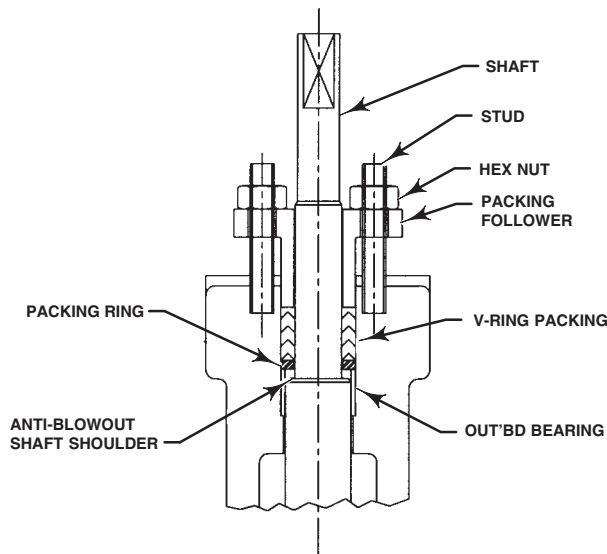

16B5082 / DOC

3- THROUGH 12-INCH SIZES

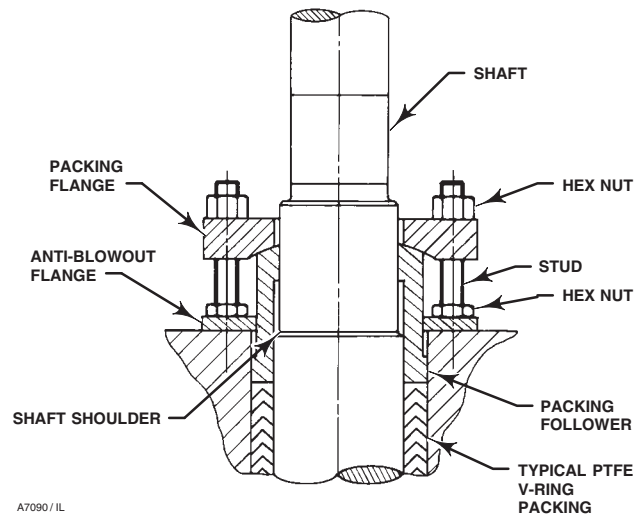

A7090 / IL

14- THROUGH 24-INCH SIZES

Figure 6. Anti-Blowout Protection Detail

appropriate for the valve size. If a vise or other clamps are being used, make certain the flange gasket sealing area of the valve body is not damaged.

7. Manually rotate the drive shaft (key 4) to turn the disc clockwise to meet the seal ring.
8. Place a piece of rubber, or other soft material, between the disc and internal travel stop to protect the disc. With a rubber mallet, tap the disc until it contacts the internal travel stop. When the disc makes contact with the stop, manually rotate the disc counterclockwise back out of the seal ring to a 90-degree open position.
9. The final seating of the retaining ring screws can now be done. For the screw torque values, refer to table 5.
10. Repeat steps 7 and 8 two more times.

Note

When attaching the actuator to the valve, make sure the valve disc is not in contact with the internal travel stop. The valve disc should be positioned from 0.03 to 0.76 mm (0.001 to 0.030 inch) away from the internal stop in the valve body.

CAUTION

When using an actuator, the actuator travel stops or the actuator travel (for actuators without adjustable stops) must be adjusted so that the disc stop in the valve body does not absorb the output of the actuator. Failure to limit actuator travel as described in the next step can result in damage to the valve shaft or other valve parts.

11. Use an appropriate tool (such as a feeler gauge) and position the disc from 0.03 to 0.76 mm (0.001 to 0.030 inch) away from the internal stop in the valve body.

This adjustment is necessary to be **certain** that the actuator output **torque is fully absorbed** by the **actuator travel stop or by the actuator**. The internal travel stop in the valve body should not absorb any of the actuator torque.

Anti-Blowout Protection, Packing, Valve Shaft(s), Disc, and Bearing Maintenance

Note

The 10- through 24-inch Class 150 valves and 8- through 24-inch Class 300 valves have a two-piece shaft. The

shaft with the double D or keyed end is called the drive shaft.

The 3- through 8-inch Class 150 valves and 3 through 6-inch Class 300 valves have a one-piece shaft.

Disassembly



WARNING

The edges of a rotating valve disc (key 3) have a shearing effect that might result in personal injury. To avoid personal injury, keep clear of the disc edges when rotating the disc.

CAUTION

When removing the actuator from the valve, do not use a hammer or similar tool to drive the lever off the valve shaft. Driving the lever or actuator off the valve shaft could damage the valve internal parts.

If necessary, use a wheel puller to remove the lever or actuator from the valve shaft. It is okay to tap the wheel puller screw lightly to loosen the lever or actuator, but hitting the screw with excessive force could also damage internal valve parts.

Never use a wrench or pliers on the drive shaft. A damaged shaft could cut the packing and allow leakage.

Unless otherwise indicated, key numbers and part names are listed in figures 7 and 8.

1. Remove the actuator and valve, as an assembly, from the pipeline, and then remove the actuator from the valve.

Note

It is not necessary to remove the retaining ring and seal ring when removing the shaft(s) and disc.

2. Secure the valve in an upright position. Rotate the disc (key 3) 180 degrees counterclockwise from the fully closed position by manually turning the drive shaft.

3. Remove the Anti-Blowout Protection (refer to figure 6). Remove the hex nuts and pull out the packing follower.

Note

Class 150 and 300 3- through 24-inch valve sizes have a bearing stop pressed into the bearing bore of the valve body below the extension housing.

Do not attempt to remove the bearing stop. If the bearing stop needs replacement, contact your Fisher sales office for more information.

4. Remove the packing from around the drive shaft.

Note

Different valves require slightly different procedures because different valve sizes/ pressure classes have different methods of connecting the disc and shaft(s). To identify the proper procedures, refer to the list below.

- **Class 150, 3- through 8-inch sizes: One-piece shaft with 1 taper key.**

- **Class 150, 10- and 12-inch sizes: Two-piece shaft. 1 taper key in the drive shaft; 1 disc pin in the follower shaft.**

- **Class 300, 3- through 6-inch sizes: One-piece shaft with 1 taper key.**

- **Class 300, 8- and 10-inch sizes: Two-piece shaft. 1 taper key in the drive shaft; 1 disc pin in the follower shaft.**

- **Class 300, 12-inch size: Two-piece shaft with 2 tangential pins in the drive shaft; 1 disc pin in the follower shaft.**

- **Class 150 and 300, 14- through 24-inch sizes: Two-piece shaft with 2 tangential pins in the drive shaft; 1 disc pin in the follower shaft.**

5. Proceed as appropriate, using the following instructions.

For valves with taper key(s), locate the taper key(s) (key 6) which runs through the drive shaft boss on the back of the valve disc. Using a pin punch on the smaller end of the key, drive it out of

Cryogenic-Rotary Valve

the disc and shaft. Driving a taper key in the wrong direction will tighten it.

Note

Certain valve sizes may have a taper key that is arc spot welded in place. To remove the key, use a punch on the smaller end of the taper key and drive it out of the disc and shaft, breaking the weld.

For valves with tangential pins and/or disc pins, locate the tangential pins (key 6) in the drive shaft (key 4) and the disc pin (key 6) in the follower shaft (key 5).

a. If a maintenance kit is available, use the pin extractor to remove the disc pins. Select the correct size pin extractor tip with screws of proper thread size to match the thread size in the disc pins. If a maintenance kit is not available, see steps c and d below.

b. Screw the pin extractor tip into the pin as far as possible. With an upward, straight sliding motion, pull out the pin. Repeat the same procedure for the other pins.

c. Use a threaded rod with an appropriate spacer and nut as an extractor tool. If using a threaded rod, choose a rod with threads that fit the inside thread of the pins. The rod should extend several inches above the disc when it is screwed into a pin.

d. After screwing the rod into the pin, slide the spacer over the rod and pin. Thread the nut onto the rod and tighten it. As the nut is tightened, the nut will drive the spacer against the disc. The increasing force will draw the pin from the disc.

6. Valves with a two-piece shaft have a gasket retainer and gasket (keys 14 and 15) on the follower shaft side of the valve. Remove the hex head bolts and lockwashers (keys 21 and 20) from the gasket retainer and remove the gasket retainer and gasket to expose the end of the follower shaft.

7. Support the valve disc properly, and remove the follower shaft. Pull the follower shaft from the valve body. Use a shaft extractor screwed into the puller hole in the end of the follower shaft.

8. Support the valve disc properly, and remove the drive shaft. Pull out the drive shaft (key 4) by hand-pulling or by using a shaft extractor screwed

into the end of the shaft. Keep the packing box ring (key 12) which will come out with the drive shaft.

CAUTION

To avoid damage to the disc, seal ring, and T-slot area, do not force the disc past the seal or T-slot area. Remove the disc from the opposite side of the valve body.

9. After removing the shaft(s), remove the disc and the thrust bearings (key 28). Do not force the disc past the seal ring or T-slot area.

10. Remove the journal bearings (key 9). Using a suitable punch or puller, drive or pull the journal bearing(s) into the valve body bore from the drive shaft bearing bore. Do not attempt to remove the bearing stop. Remove the journal bearing from the follower shaft bearing bore. Also, remove the outboard bearing from the extension housing (if applicable).

11. Inspect the valve body bore, bearings, bearing bores and packing box for damage.

Installing a One-Piece Shaft

Unless otherwise indicated, key numbers and part names are listed in figures 7 and 8.

1. Secure the valve in an upright position. Allow for easy access to the valve body bore. Allow for easy access to the drive shaft bearing bore.

2. Inspect all parts removed from the valve for wear or damage. Replace any worn or damaged parts. Clean the valve body and all parts to be installed with an appropriate solvent or degreaser.

CAUTION

Premature valve failure and loss of process control may result if bearings are improperly installed or are damaged during installation.

3. Using caution to prevent damage to the bearing, insert one journal bearing (key 9) from the valve body bore into the drive shaft bearing bore until it hits the bearing stop. When properly installed, a portion of the journal bearing will extend into the valve body bore.

4. Insert one journal bearing from the valve body bore into the shaft bearing bore opposite the journal bearing installed in step 3. When correctly installed,

this journal bearing will be flush with the valve body bore.

5. Insert the outboard journal bearing (key 10) into the bore on top of the extension housing.
6. Install the valve disc by placing the disc into the valve body bore so the curved side of the disc passes through the end of the valve body that does not contain the T-slot. Align the shaft bore in the disc with the bearing bores.
7. Insert the drive shaft end opposite the double D or keyed end into the valve body through the packing box. Push the shaft through the bearing stop. Taking care not to dislodge the journal bearing, push the shaft through the journal bearing and the valve disc and into the bore on the opposite side of the valve body.

CAUTION

To avoid damage to the taper key, tangential pins, disc pins, valve disc, or shaft(s) resulting from the application of excessive force, use appropriate care when driving the key or pins into the disc hub and shaft(s). Use the right tool. Do not use excessive force.

8. Be sure the taper key disc shaft joint is free of oil or grease. If necessary, remove any excess welding material from the taper key.
9. Align the taper key hole in the shaft with the holes in the shaft boss on the disc. Insert the taper key. Use a flat-end punch to drive the taper key until solid contact is felt. Measure the depth of the taper key head for a reference during the following steps.

- a. Drive the taper key in farther as follows:

Valve Size, Inches	Minimum Depth to Drive Taper key After Initial Solid Contact, mm (Inches)
ANSI Class 150 and 300, size 3, 4, 6-inch valves, and 8-inch ANSI Class 150 valves	5 (0.188)

- b. The disc, shaft, and taper key assembly must be inspected to verify that the taper key spans the entire shaft flat width. If so, this procedure is complete. If not, the taper key must be driven in farther until this condition is satisfied. However, do not exceed the following depth limits:

Valve Size, Inches	Maximum Allowable Depth to Drive Taper key After Initial Solid Contact, mm (Inches)
3, and 4-inch ANSI Class 150/300	7 (0.281)
6-inch ANSI Class 300, and 8-inch ANSI Class 150	8 (0.312)

10. After driving the taper key in place, arc spot weld the head of the taper key to the disc. For valve sizes 3-, 4-, and 6-inch, use an arc spot weld bead of 1/8-inch diameter. For valve sizes 8-, 10-, and 12-inch sizes, use an arc spot weld bead of 3/16-inch diameter.
11. Install the packing as described in the Packing Replacement section.

Installing a Two-Piece Shaft

Unless otherwise indicated, key numbers and part names are listed in figures 7 and 8.

1. Secure the valve in an upright position. Allow for easy access to the valve body bore. Allow for easy access to the drive shaft bearing bore and the follower shaft bearing bore.
2. Inspect all parts removed from the valve for wear or damage. Replace any worn or damaged parts. Clean the valve body and all parts to be installed with an appropriate solvent or degreaser.

CAUTION

Premature valve failure and loss of process control may result if bearings are improperly installed or are damaged during installation.

3. Using caution to prevent damage to the bearings, insert the required number of journal bearings (key 9) from the valve body bore into the drive shaft bearing bore. When properly installed, one end of the journal bearing(s) will be flush with the interior end of the extension housing, the other end of the journal bearing(s) will be flush with the valve body bore.

The drive shaft thrust bearing (key 28) will be installed in step 6.

4. Insert one journal bearing from the valve body bore into the follower shaft bearing bore so it is flush with the valve body bore.
5. Insert the outboard journal bearing (key 10) into the bore on top of the extension housing.
6. Insert the drive shaft into the valve body through the extension housing . Push the drive shaft through

Cryogenic-Rotary Valve

the journal bearing(s). Hold the drive shaft thrust bearing (key 28) in the valve body bore against the opening of the drive shaft bearing bore. Push the drive shaft through the bearing bore just enough to hold the thrust bearing.

7. Insert the follower shaft through the bore in the valve body uncovered by removal of the gasket retainer. Hold the follower shaft thrust bearing (key 28) in the valve body bore against the opening of the follower shaft bearing bore. Push the follower shaft through the bearing bore just enough to hold the thrust bearing.

8. Install the valve disc. Place the flat side of the disc on a flat surface. Then, move the valve body from its upright position and suspend the valve body over the disc so the seal ring/T-slot area is facing up. Align the shaft bores through the disc with the drive shaft and follower shaft bores. Lower the valve body over the disc using caution not to dislodge or damage the thrust bearings placed on the ends of the shafts.

9. With the valve disc properly positioned in the valve body, push the drive shaft and follower shaft the rest of the way through the thrust bearings and into the shaft bores in the valve disc.

10. Align the holes in the shafts with the holes in the disc.

CAUTION

To avoid damage to the taper key, tangential pins, disc pins, valve disc, or shaft(s) resulting from the application of excessive force, use appropriate care when driving the key or pins into the disc hub and shaft(s). Use the correct tool, and do not use excessive force.

11. Before installing the taper key, be sure the taper key disc shaft joint is free of oil or grease. If necessary, remove any excess welding material from the taper key.

12. Install the appropriate taper key, tangential pins, and disc pins. Install the taper key by aligning the taper key hole in the shaft with the holes in the shaft boss on the disc. Insert the taper key. Use a pin punch to drive the taper key until solid contact is felt. Measure the depth of the taper key head for a reference during the following steps.

a. Drive the taper key in farther as follows:

Valve Size, Inches	Minimum Depth to Drive Taper key After Initial Solid Contact, mm (Inches)
8-inch ANSI Class 300, 10- and 12-inch ANSI Class 150, and 10-inch ANSI Class 300 valves	6 (0.219)

b. The disc, shaft, and taper key assembly must be inspected to verify that the taper key spans the entire shaft flat width. If so, this procedure is complete. If not, the taper key must be driven in farther until this condition is satisfied. However, do not exceed the following depth limits:

Valve Size, Inches	Maximum Allowable Depth to Drive Taper key After Initial Solid Contact, mm (Inches)
8-inch ANSI Class 300, and 10- and 12-inch ANSI Class 150	10 (0.375)
10-inch ANSI Class 300	11 (0.406)

13. After driving the taper key in place, arc spot weld the head of the taper key to the disc. For valve sizes 8-, 10- and 12-inch, use an arc spot weld bead of 3/16-inch in diameter.

14. Install the packing as described in the Packing Replacement section.

Installing the Gasket Retainer

Valves with a two-piece shaft use a gasket retainer and gasket to cover the follower shaft opening in the valve body.

1. Replace the gasket (key 15) and gasket retainer (key 14) over the end of the follower shaft. Use a new gasket.

2. Replace the four hex head bolts (key 21) and lockwashers (key 20) to hold the gasket retainer in place.

3. Be sure to center the gasket over the follower shaft bore before retightening the bolts. Tighten down the bolts evenly in a crossover or star pattern. Refer to table 5 for proper torque values.

Parts Ordering

When corresponding with your Fisher sales office about the Type A31A Cryogenic valve, always provide the valve serial number. For valve/actuator combinations assembled at the factory, the valve serial number is stamped on the nameplate attached to the actuator. **For parts information on the 14-through 24-inch sizes, please contact your Fisher sales office.**

Note

Use only genuine Fisher replacement parts. Components that are not supplied by Fisher should not, under any circumstances, be used in any Fisher valve, because they will void your warranty, might adversely affect the performance of the valve, and might jeopardize worker and workplace safety.

Note

Neither Emerson, Emerson Process Management, nor Fisher assume responsibility for the selection, use, or maintenance of any product. Responsibility for proper selection, use, and maintenance of any Fisher product remains solely with the purchaser and end-user.

Parts List

Note

Part numbers are shown for recommended spares only. For part numbers not shown, contact your Fisher sales office.

Key	Description	Part Number
1	Valve Body If you need a valve body as a replacement part, order by valve size, serial number, and desired material. Contact your Fisher sales office for assistance.	
2	Retaining Ring	
3	Disc	
4	Shaft	
5	Follower Shaft (8-inch size, Class 300 only)	
6*	Taper Key	
	3 & 4-inch	12B9530X012
	6-inch	12B9531X012
	8-inch Class 150	12B9531X012
	8-inch Class 300	12B9532X012

Key	Description	Part Number
7*	Seal Ring	
	3-inch	
	Kel-F	V152339X012
	Kel-F w/ backup ring	V160696X012
	NOVEX S31600, Class 150	V158982X042
	NOVEX Nit 60, Class 300	V158982X052
	4-inch	
	Kel-F	V152340X012
	Kel-F w/ backup ring	V155891X012
	NOVEX S31600, Class 150	V158984X042
	NOVEX Nit 60, Class 300	V158984X052
	6-inch	
	Kel-F	V152341X012
	Kel-F w/ backup ring	V156065X012
	NOVEX S31600, Class 150	V158987X042
	NOVEX Nit 60, Class 300	V158987X052
	8-inch	
	Kel-F, Class 150	V152342X012
	Kel-F, Class 300	V114263X012
	Kel-F w/ backup ring, Class 150	V159653X012
7*	Seal Ring (continued)	
	8-inch	
	Kel-F w/ backup ring, Class 300	V153418X012
	NOVEX S31600, Class 150	V158992X022
	NOVEX Nit 60, Class 300	V163822X012
8*	Backup Ring, Aluminum	
	3-inch	V160709X012
	4-inch	V155890X012
	6-inch	V156066X012
	8-inch, Class 150	V159654X012
	8-inch, Class 300	V153419X012
9*	Bearing, Journal (2 req'd) (4 req'd for 8-inch Class 300)	
	PTFE	
	3-inch	V166484X062
	4-inch	V153101X012
	6-inch	V166462X072
	8-inch, Class 150	V167379X062
	8-inch, Class 300	V166460X072
	Bronze	
	3-inch	V166484X022
	4-inch	V166485X022
	6-inch	V166462X032
	8-inch, Class 150	V167379X052
	8-inch, Class 300	V166460X052
10*	Bearing, Outboard	
	PTFE	
	3-inch	16B3488X012
	4-inch	16B3574X012
	6-inch	16B3748X012
	8-inch, Class 150	16B3748X012
	8-inch, Class 300	16B3991X012
	Bronze	
	3-inch	16B3488X022
	4-inch	16B3574X022
	6-inch	16B3748X022
	8-inch, Class 150	16B3748X022
	8-inch, Class 300	16B3991X022
11	Packing Follower, SST	
12*	Packing Box Ring	
	3-inch	16A6083X012
	4-inch	16A6084X012
	6-inch	16A6085X012
	8-inch, Class 150	16A6085X012
	8-inch, Class 300	16A6086X012

Cryogenic-Rotary Valve

Key	Description	Part Number	Key	Description	Part Number
13*	Packing Set, PTFE		17	Stud (2 req'd)	
	3-inch	1R5795X0012	18	Hex Nut (2 req'd)	
	4-inch	12A8995X022	19	Retaining Ring Screw	
	6-inch	12A8832X022	20*	Lock Washer	
	8-inch, Class 150	12A8832X022		8-inch, Class 300 only	T10226X0012
	8-inch, Class 300	12A8951X022	21	Hex Head Bolt	
13*	Packing Ring, graphite (4 req'd)			8-inch, Class 300 and larger	
	3-inch	12A9131X012	22	Pipe Plug, optional	
	4-inch	12A9136X012	23	Nameplate (not shown)	
	6-inch	12A9137X012	24	Drive Screw (2 req'd) (not shown)	
	8-inch, Class 150	12A9137X012	25	Flow Direction Arrow (not shown)	
	8-inch, Class 300	12A9138X012	26	Assembly, Disc/Shaft	Contact factory
13*	Packing Washer, graphite (3 req'd)		27	Key	
	3-inch	14A9771X012		3-inch	V146070X012
	4-inch	14A8363X012		4-inch	V146071X012
	6-inch	14A8365X012		6-inch	V146072X012
	8-inch, Class 150	14A8365X012		8-inch	V146072X012
	8-inch, Class 300	14A8366X012	28*	Thrust Bearing (2 req'd) (not shown)	
14	Gasket Retainer			8-inch, Class 300 only, PTFE	V166461X062
	8-inch, Class 300 and larger			8-inch, Class 300 only, Bronze	V166461X022
15*	Gasket		29	Key Retainer Bolt	
	8-inch, Class 300 only	V124605X012		3- & 4-inch	V110745X012
16*	Retaining Ring Gasket			6- & 8-inch	V115603X012
	3-inch	V143529X012	30	Key Retainer Washer	
	4-inch	V143494X012		3- & 4-inch	V128487X012
	6-inch	V143458X012		6-inch	V153099X012
	8-inch, Class 150	V143656X012		8-inch	V1115723X012
	8-inch, Class 300	V143657X012			

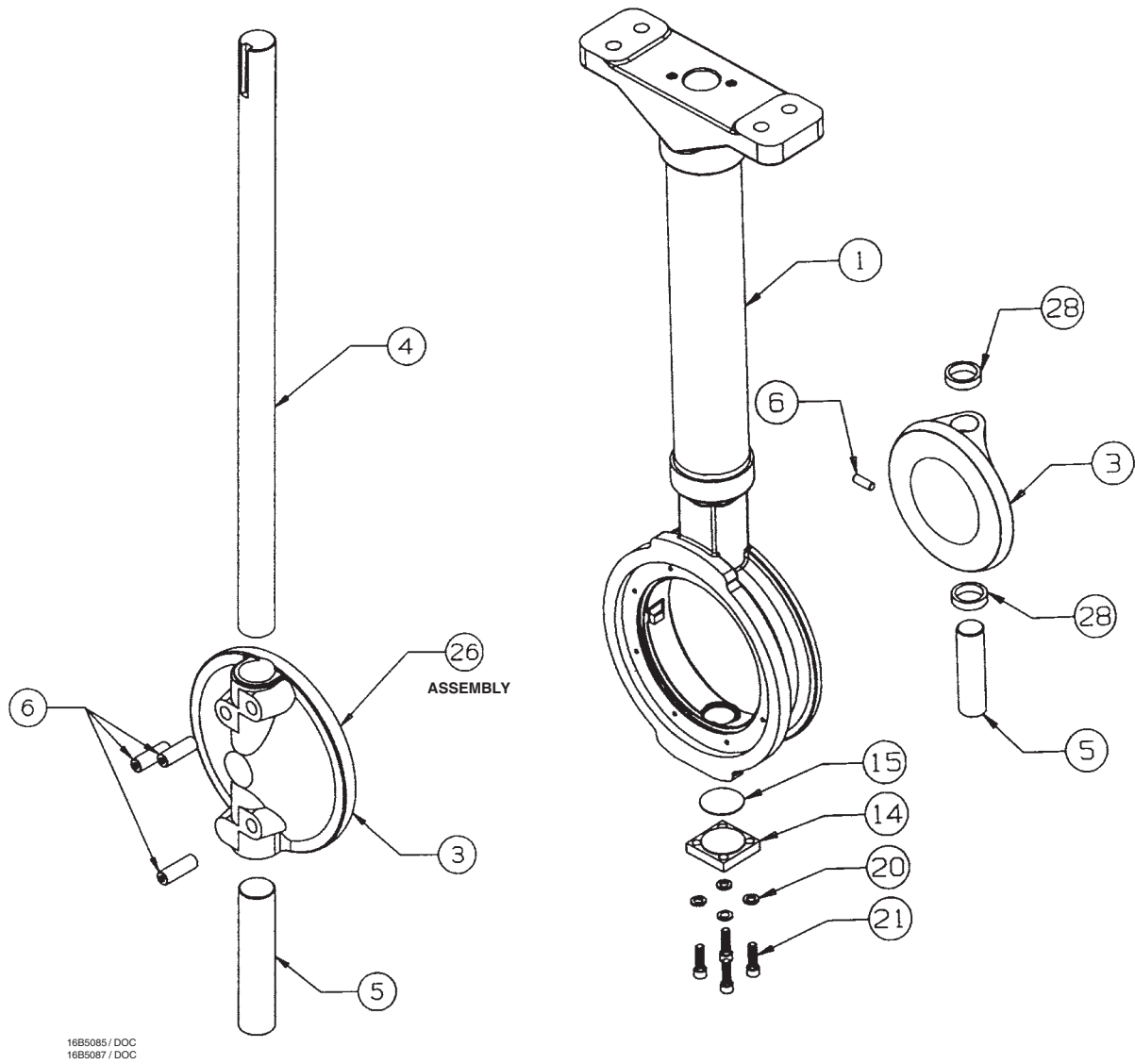

16B5085 / DOC
16B5087 / DOC

Figure 7. Type A31A Cryogenic 3 through 12-inch Typical Assembly (continued)

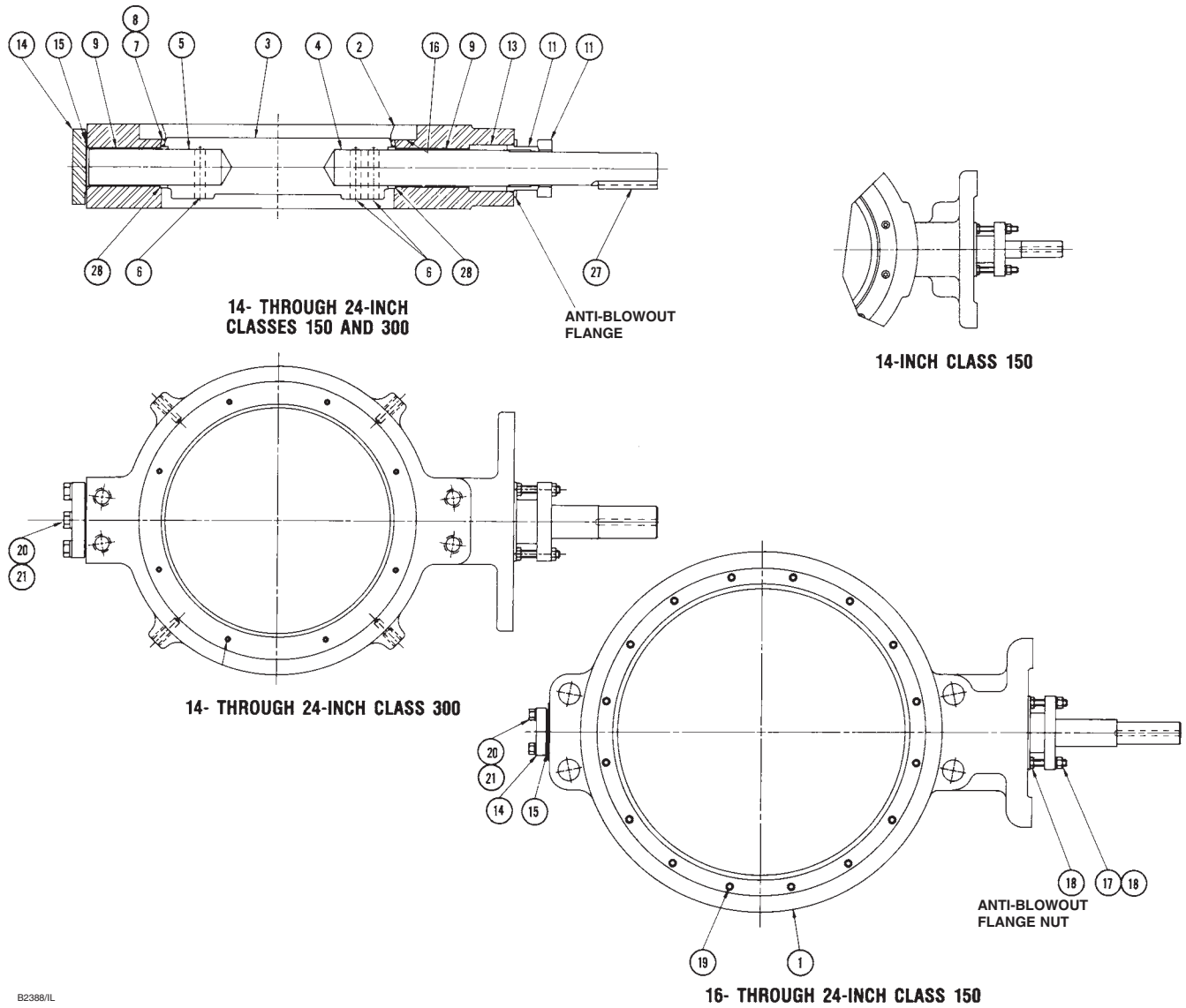

B2388/IL

Figure 8. 14- through 24-Inch Type A31A Cryogenic Valves (Wafer Style Shown)
(Shown without 2-piece Extension Housing)

Cryogenic-Rotary Valve

Instruction Manual
Form 5482
February 2005

Cryogenic-Rotary Valve

Instruction Manual

Form 5482

February 2005

POSI-SEAL, NOVEX, and Fisher are marks owned by Fisher Controls International LLC, a member of the Emerson Process Management business division of Emerson Electric Co. The Emerson logo is a trademark and service mark of Emerson Electric Co. All other marks are the property of their respective owners.

The contents of this publication are presented for informational purposes only, and while every effort has been made to ensure their accuracy, they are not to be construed as warranties or guarantees, express or implied, regarding the products or services described herein or their use or applicability. We reserve the right to modify or improve the designs or specifications of such products at any time without notice.

Neither Emerson, Emerson Process Management, nor Fisher assume responsibility for the selection, use or maintenance of any product. Responsibility for proper selection, use and maintenance of any Fisher product remains solely with the purchaser and end-user.

Emerson Process Management

Fisher

Marshalltown, Iowa 50158 USA

Cernay 68700 France

Sao Paulo 05424 Brazil

Singapore 128461

www.Fisher.com

