

# Fisher® V260 Ball Control Valve

The Fisher V260 is a full-bore control valve designed from the ground up with features for optimized pressure, flow and process control. An integral drilled attenuator controls noise and vibration from high pressure drop liquids and gases. The splined shaft connection to the actuator reduces lost motion.

The V260A with Aerodome attenuator, V260B with Hydrodome attenuator, and V260C Ball Control Valves (figures 1 and 3) combine the efficiency of a rotary valve with the energy-dissipating capability of a special trim to provide improved performance for demanding applications. The valve is available with single, dual, or dual block-and-bleed seal options (see the Specifications table).

The trim design of the V260A is used in gas service to reduce noise effects that cause pipeline vibration. The V260B provides improved performance for demanding applications such as pump bypass and pipeline take-off. The trim is designed for liquid service to help eliminate or reduce cavitation and associated pipeline noise and vibration. The V260C full-bore ball valve is designed for automated control in bypass, batch, monitor, and emergency shutoff service applications, and it presents little or no restriction to flow.

The V260 full-bore ball valve is available with composition seals, and process type stem packing for improved service life.

Unless otherwise noted, all NACE references are to NACE MR0175-2002.

## Features

- **Excellent Flow Control**-- The splined ball to shaft connection, splined shaft to actuator connection, double power-end bushing assemblies, and trunnion guiding, all provide improved dynamic control.

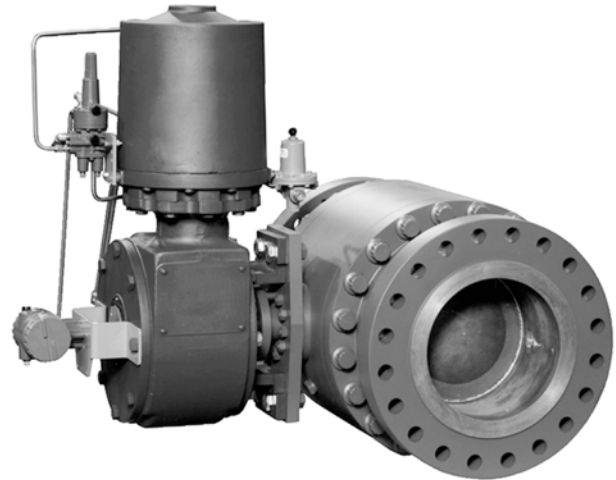

Fisher V260 Valve

- **Aerodynamic Performance**-- Up to -20 dBA acoustical attenuation can be achieved for the V260A within a single stage construction. Dual-stage construction can provide up to -25 dBA attenuation.
- **Improved Service Life**-- The attenuator is not part of the seal assembly. The seal wipes to ball surface, not the attenuator, promoting increased service life.
- **Trim Versatility**-- Key valve components, such as valve body, ball, shaft and bearings, are interchangeable between the V260A, V260B and V260C. This feature allows you to reduce your spare parts inventory and maintenance time.

*(continued on page 2)*



**Specifications**

**Valve Body Sizes and End Connection Styles**

NPS ■ 8, ■ 10, ■ 12, ■ 16, ■ 20, and ■ 24 flanged valves with CL150, CL300, or CL600 raised-face flanges compatible with ASME B16.5. Consult your Emerson Process Management sales office for other end style connections.

**Maximum Inlet Pressures and Temperatures<sup>(1)</sup>**

Consistent with CL150, CL300, or CL600 pressure-temperature ratings per ASME B16.34

**Maximum Allowable Shutoff Pressure Drop<sup>(1)</sup>.**

For Single-Seal and Dual-Seal Construction (Except where further limited by the pressure-temperature rating of the valve body):

- CL150: 20 bar (285 psi) at 38°C (100°F)
- CL300: 51 bar (740 psi) at 38°C (100°F)
- CL600: 103 bar (1480 psi) at 38°C (100°F)

**Flow Characteristic**

- Modified linear with single high density attenuator,
- Modified equal percentage with single characterized attenuator (see figure 2), or
- Modified equal percentage without attenuator

**Flow and Shutoff Direction**

Unidirectional flow for V260 is forward flow. Seal is upstream.

- **Single Seal Constructions:** Should be used for unidirectional flow and unidirectional shutoff only.
- **Double Seal Constructions:** V260A and V260C may be used for unidirectional and bidirectional flow. V260B should be used for unidirectional flow only for effective anti-cavitation protection. Bidirectional shutoff requires the dual seal construction.

**Flow Coefficients**

See Fisher Catalog 12

**Shutoff Classification**

**Single-Seal Composition Constructions:** 0.001% of maximum valve capacity (less than 10% of ANSI/FCI 70-2 Class IV and IEC 60534-4)

**Dual-Seal Composition Constructions:** 0.001% of maximum valve capacity (less than 10% of ANSI/FCI 70-2 Class IV and IEC 60534-4)

**Seal Material and Temperature Capability<sup>(1)</sup>**

**Standard:** ■ POM (polyoxymethylene) -29 to 82°C (-20 to 180°F)

**Optional:** ■ PTFE/PEEK<sup>(2)(3)</sup> -29 to 93°C (-20 to 200°F)

**Maximum Ball Rotation**

90 degrees

**Actuator Mounting**

Right-hand or left-hand mounted as viewed from the valve inlet for forward flow

**Packing Arrangements**

**PTFE Packing:** Standard construction (see figure 4)

**ENVIRO-SEAL™ Packing:** This optional packing system provides improved sealing, guiding, and transmission of loading force to control liquid and gas emissions. Contact your Emerson Process Management sales office for availability of ENVIRO-SEAL packing (see figure 4)

**Dimensions**

See figure 5

**Options**

- Double block-and-bleed applications (Dual-seal construction is required),
- Two Stage V260A Attenuator,
- Two or Three Stage V260B Attenuator,
- CL900 flanges,
- Ring type joint flanges

1. The pressure/temperature limits in this bulletin and any applicable standard or code limitation for this valve should not be exceeded.

2. PTFE stands for Polytetrafluoroethylene, and PEEK stands for PolyEtherEtherKetone.

3. Temperature limit of PTFE/PEEK is limited due to standard Nitrile O-Ring. Contact your Emerson Process Management sales office for higher temperature options, up to 232°C (450°F).

**Features (continued)**

- **Sour Service and Sour Crude Oil Capability--** Optional materials are available that comply with NACE Standard MR0175-2002.

- **Tight Shutoff--** Self-adjusting seal(s) that are pressure assisted provide tight shutoff for long reliable service. The design incorporates a heavy duty S31600 stainless steel carrier that retains the composition seal for full-rated pressure drop service.

- **Heavy Duty Trunnion**-- The ball trunnions are designed for demanding applications requiring long service life, with a reduction in maintenance time and costs.
- **Broad Hydrodynamic Applications**-- Single, dual, and three-stage attenuators for the V260B may be provided for a varying range of applications. A  $K_c$

value of 1.0 is achievable depending on service conditions.

- **Flexible Applications**-- The attenuator is active throughout the ball rotation for very demanding services or a characterized attenuator is used to match the service conditions (see figure 2).

Table 1. Aerodome and Hydrodome Trim Benefits Comparison

Benefits	Typical Competitive Device	V260A with Aerodome Attenuator	V260B with Hydrodome Attenuator
Up to -20 dBA aerodynamic noise attenuation	No	Yes	N/A
Excellent attenuation effect at critical opening position	No	Yes	Yes
High Density (Full) or characterized attenuation	No	Yes	Yes
2 or 3 stage options	No	Yes	Yes
Effective bidirectional attenuation option	No	Yes	Yes
Integrated ball, shaft, and attenuator design for best throttling dynamics	No	Yes	Yes
Dual seal option	No	Yes	Yes
Ball seal exchange without actuator removal	No	Yes	Yes
$K_c$ improved versus unattenuated device	Yes	N/A	Yes
Double block-and-bleed option	No	Yes	Yes
Overall ease of maintenance	No	Yes	Yes
Trunnion-mounted ball for excellent wear resistance	Yes	Yes	Yes
Low profile for ease of piping	Yes	Yes	Yes

Table 2. Standard Materials of Construction

Part	Material
Valve Body	LF2 Carbon Steel
Ball	WCC Carbon Steel
Seal	POM with S31600 SST Seal Blank or PTFE/PEEK with S31600 SST Seal Blank
Dome Attenuator	S17400 SST
Shaft	S17400 SST H1075 or S17400 SST H1150 DBL
Wave Spring	S17700 SST or N07750
Tailpiece	LCC Carbon Steel
Tailpiece Mounting Bolting	B7 Steel or B7M Steel
Bearing Plate	Carbon Steel
Bearings	S30400 SST with Aramid liner
Thrust Washer	Carbon filled PTFE
Packing Box Housing	LCC Carbon Steel
Packing	PTFE/Carbon filled PTFE
Packing Bolting	B7 Steel, B7M Steel, or B8M Class 2 SST
Packing Follower, Packing Box Ring	Annealed S31600 SST
Groove Pins	B8M SST
O-Rings	Nitrile
Actuator Mounting Bolting	Steel Grade 5

**Figure 1. Sectional View of Valve (Single Seal)**

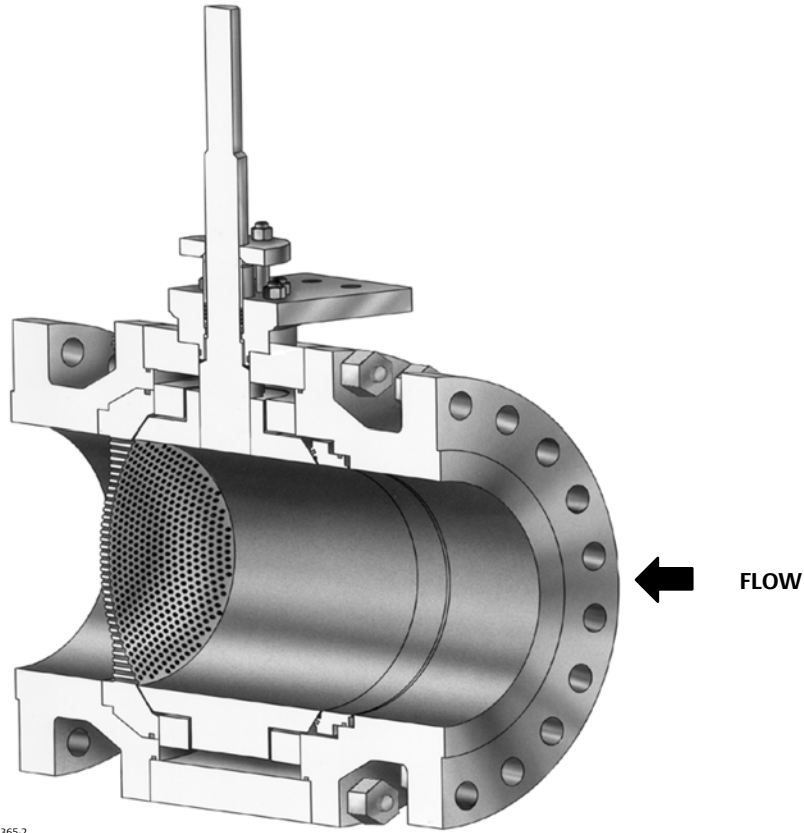

W6365-2

**Figure 2. Aerodome and Hydrodome Attenuator Details**

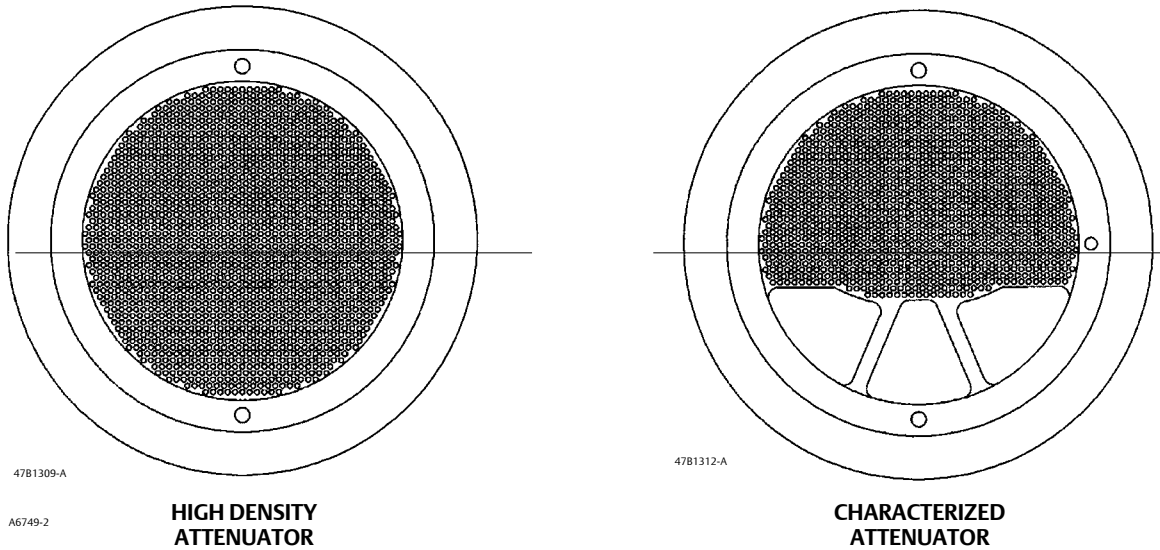

4781309-A

A6749-2

**HIGH DENSITY  
ATTENUATOR**

4781312-A

**CHARACTERIZED  
ATTENUATOR**

Figure 3. Typical Fisher V260 Valve Assembly

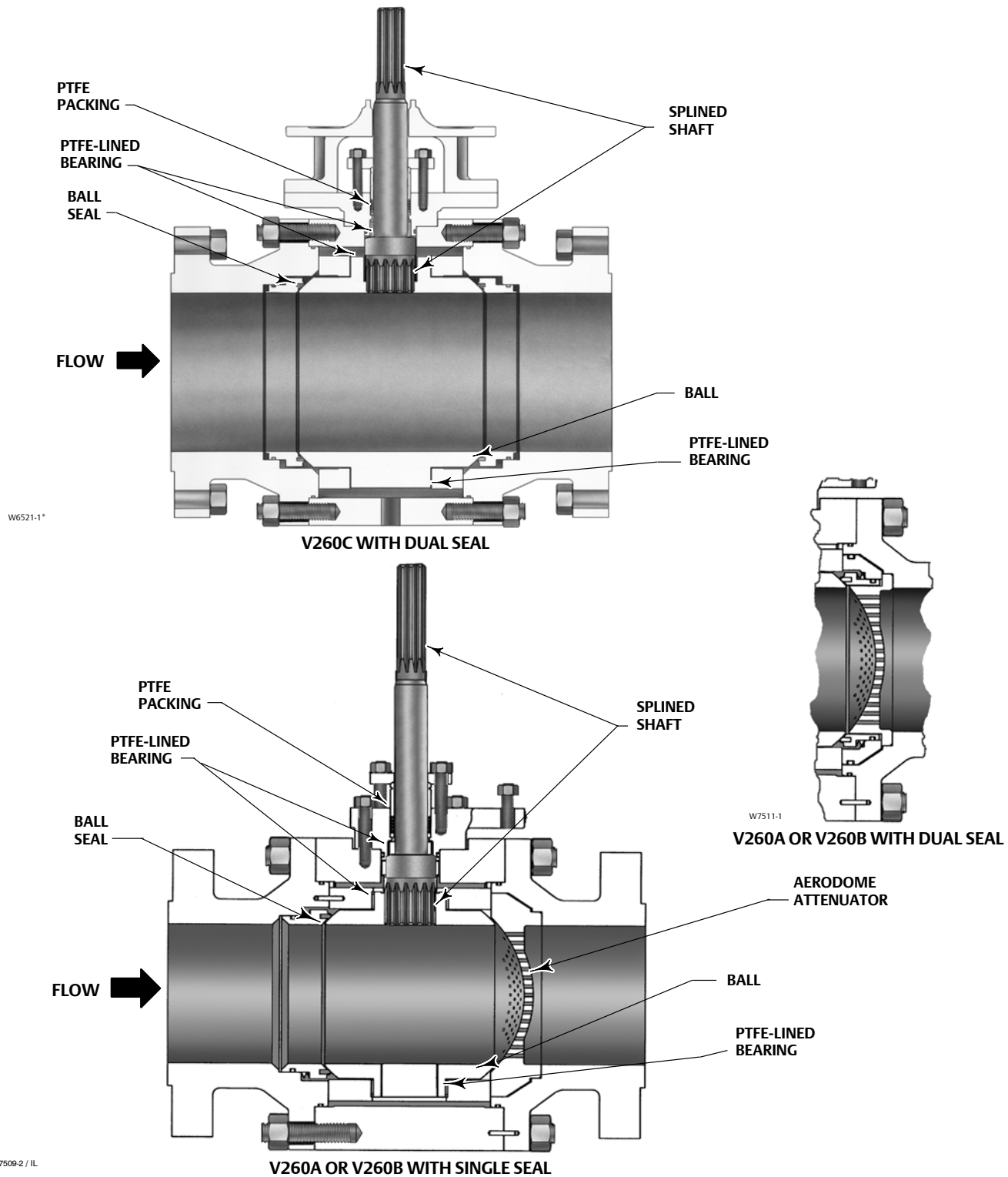
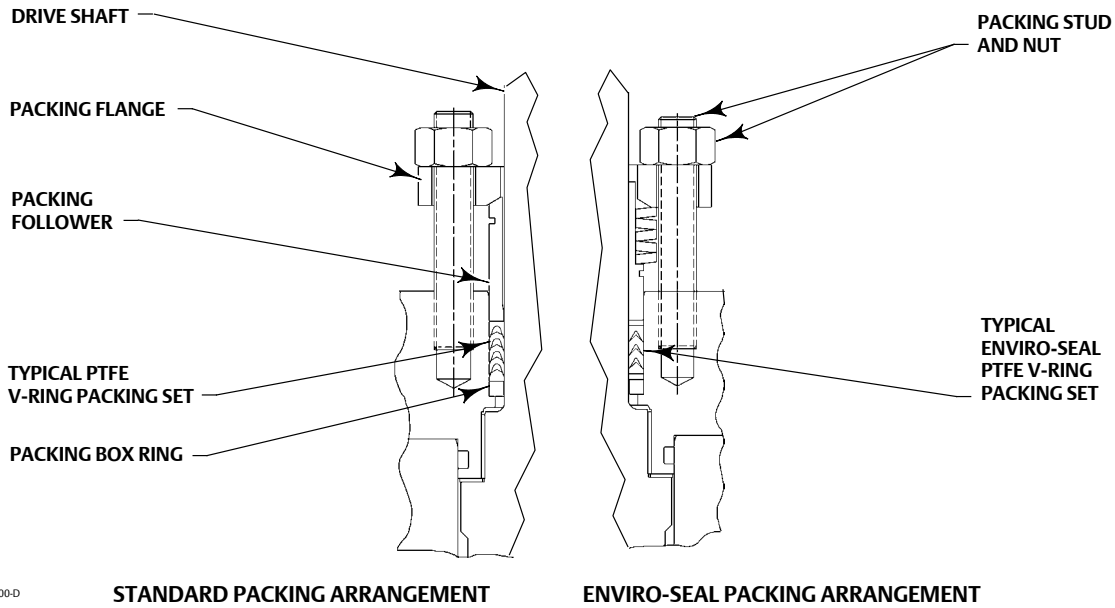

Figure 4. Packing Arrangement Details



94BA02200-D  
B2472-1

Table 3. Dimensions

VALVE SIZE, NPS	A	D	K	R $\emptyset$	S $\emptyset$		T	U	W (THREADED)	APPROXIMATE WEIGHT
					Shaft Dia.	Spline Dia.				
<b>mm</b>										
8	661	356	273	457	44.4	44.4	273	51	See thread info below	442
10	788		324	553	63.5	63.5	337	76		703
12	840		369	639						919
16	991	508	508	848	76.2	76.2 <sup>(1)</sup>	533	127		2472
		471			76.2	63.5 <sup>(2)</sup>				
20	1194	508	602	1040	88.9	88.9 <sup>(1)</sup>				4309
		471			88.9	63.5 <sup>(2)</sup>				
24 CL150	1397	314	671	1158	88.9	88.9 (keyed shaft)	533	127		5352
24 CL300	1397	508	708	1158	88.9	88.9	533	127		5761
24 CL600	1397	364	708	1241	102	102 (keyed shaft)	610	457 (U1) <sup>(3)</sup> 254 (U2) <sup>(3)</sup>		7076
<b>Inches</b>										
8	26.04	14.00	10.75	18.00	1-3/4	1-3/4	10.75	2.00	3/4-10	975
10	31.04		12.75	21.77	2-1/2	2-1/2	13.25	3.00	7/8-9	1550
12	33.07		14.53	25.15						2025
16	39.00	20.00	19.99	33.38	3	3 <sup>(1)</sup>	21.00	5.00	1-1/4-8	5450
		18.56			3	2-1/2 <sup>(2)</sup>				
20	47.00	20.00	23.70	40.96	3-1/2	3-1/2 <sup>(1)</sup>				9500
		18.56			3-1/2	2-1/2 <sup>(2)</sup>				
24 CL150	55.00	12.38	26.40	45.60	3-1/2	3-1/2 (keyed shaft)	21.00	5.00	1-1/4-8	11800
24 CL300	55.00	20.00	27.87	45.60	3-1/2	3-1/2	21.00	5.00	1-1/4-8	12700
24 CL600	55.00	14.32	27.87	48.86	4	4 (keyed shaft)	24.00	18 (U1) <sup>(3)</sup> 10 (U2) <sup>(3)</sup>	1-1/4-8	15600

1. For 1069 size 100 actuator.  
2. For 1061 size 100 actuator.  
3. See table 6 for NPS 24 U1 and U2 information.

Figure 5. Dimensions (also see table 3)

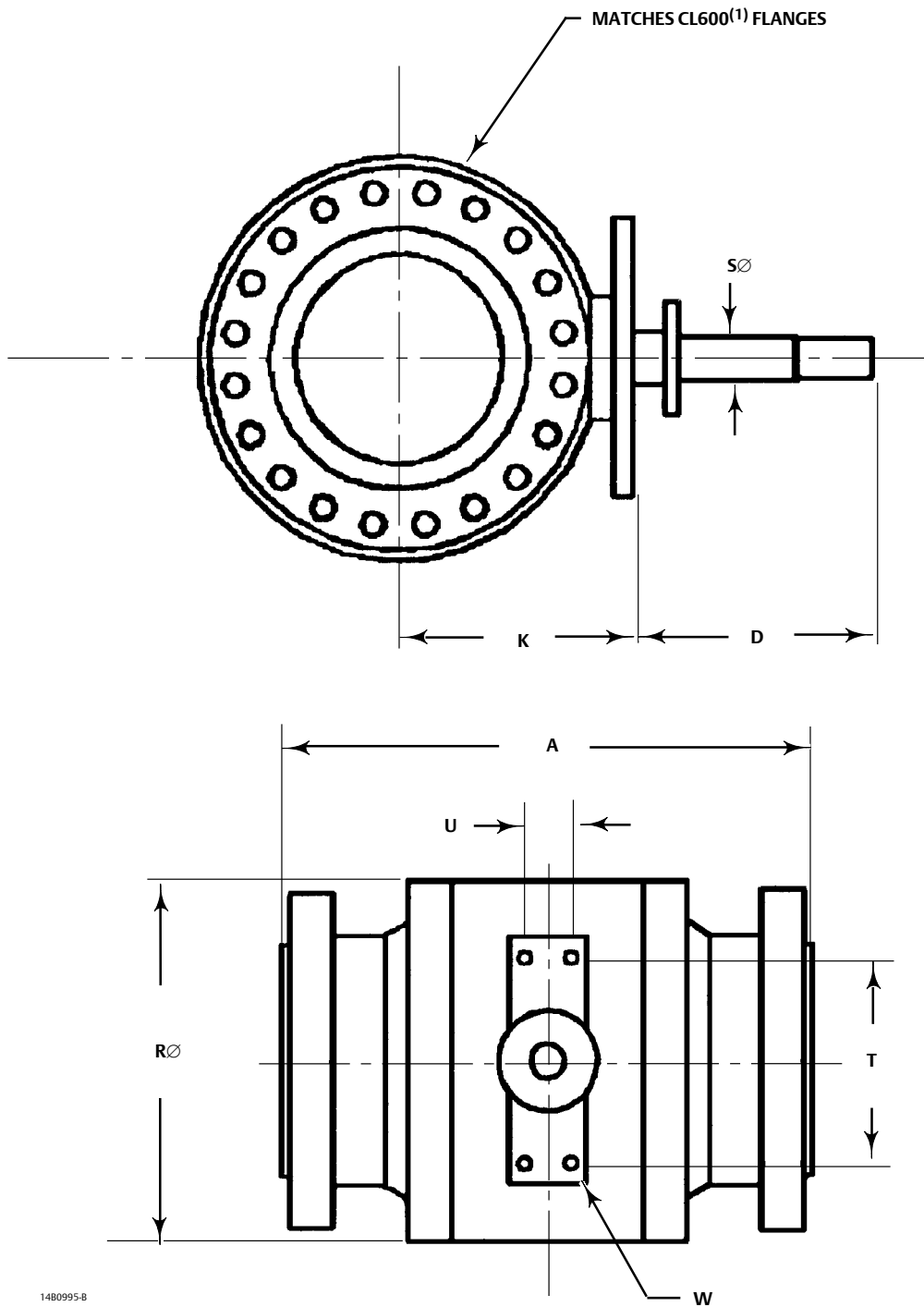

Note:  
1. For CL300 valves, face-to-face dimensions are the same as CL600 valves.  
2. Valve shown meets CL600 flanges. Flange and bolt dimensions vary for CL300 valves.

**Figure 6. NPS 24 Additional Dimensions (also see table 3)**

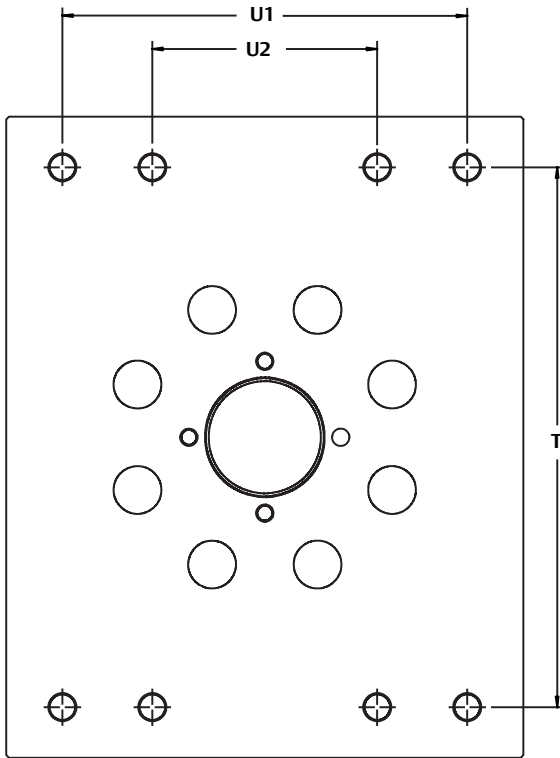

**Neither Emerson, Emerson Process Management, nor any of their affiliated entities assumes responsibility for the selection, use or maintenance of any product. Responsibility for proper selection, use, and maintenance of any product remains solely with the purchaser and end user.**

Fisher and ENVIRO-SEAL are marks owned by one of the companies in the Emerson Process Management business unit of Emerson Electric Co. Emerson Process Management, Emerson, and the Emerson logo are trademarks and service marks of Emerson Electric Co. All other marks are the property of their respective owners.

The contents of this publication are presented for informational purposes only, and while every effort has been made to ensure their accuracy, they are not to be construed as warranties or guarantees, express or implied, regarding the products or services described herein or their use or applicability. All sales are governed by our terms and conditions, which are available upon request. We reserve the right to modify or improve the designs or specifications of such products at any time without notice.

**Emerson Process Management**

Marshalltown, Iowa 50158 USA  
Sorocaba, 18087 Brazil  
Chatham, Kent ME4 4QZ UK  
Dubai, United Arab Emirates  
Singapore 128461 Singapore

[www.Fisher.com](http://www.Fisher.com)