

Fisher® V500 Rotary Eccentric Plug Control Valve

For Your Hard-to-Handle Applications



Handle Erosive Applications with the Fisher V500 Rotary Eccentric Plug Control Valve



Is damaging erosion like this occurring in your valve?

V500 valve solved a frequent trim replacement problem due to severe erosion damage from entrained sand.

V500 valve with ceramic trim extended time between unit turnarounds from three to twelve months.



Scan or click the QR code to read proven results.

Rotary Eccentric Plug Valve:

A rotary control valve with a plug-shaped, flow-restricting member that follows an eccentric path as it rotates. The plug has no contact with its seat until it turns within a few degrees of the shutoff position. As the plug contacts or “cams” into the seat, the seating surfaces dynamically align to achieve shutoff.

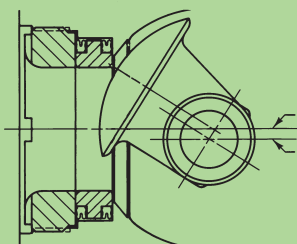

YOUR CHALLENGES

Availability is one of the key concerns in plants today. Consider this: how long do your installed rotary control valves survive in your most erosive processes? Repairing or replacing your valves repeatedly results in downtime and reduced productivity. With the Fisher V500 rotary eccentric plug control valve and its ability to battle erosion and control hard-to-handle fluids, you can reduce maintenance costs and increase plant availability.

Rotary severe service is defined as rotary control valve applications in which service or process conditions lead to constant wearing of the valve. These conditions are caused by dirty, erosive, coking, corrosive, viscous, and other hard-to-handle fluids. They can cause lack of process control, frequent maintenance, unacceptable operating life, and poor shutoff.

FISHER V500 CAPABILITIES

The Fisher V500 rotary eccentric plug valve is designed for process applications, built tough for control, and intended for performance-demanding situations. It is known for its ability to fight off the effects of hard-to-handle fluids with its rugged components and application versatility. The V500 valve has been proven in tough applications across multiple industries since being introduced in 1984.

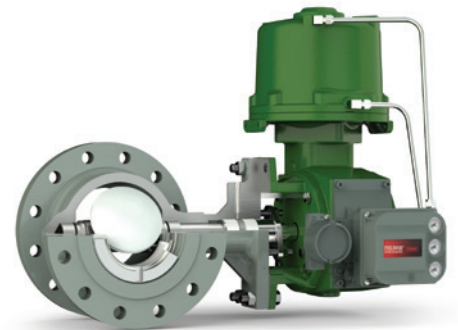

Fisher V500 valve offers:

- **Versatility** - A broad range of trim options, from 316 stainless steel to ceramic, provide the performance needed to meet the most severe, erosive applications. With these trim options, you can configure the V500 valve to meet your process requirements.
- **Total Cost of Ownership** - Quality, rugged Fisher construction enables longer lasting performance from your V500 valve. It can help you reduce maintenance costs and increase plant availability.
- **Valve Assembly Performance** - The Fisher V500 valve assembly, including a Fisher pneumatic actuator and FIELDVUE™ DVC6200 digital valve controller, provides excellent installed performance. It helps control closer to setpoint, extends operating life, and battles erosion effectively in your most critical processes.

V500: THE EROSION FIGHTER

Reverse Flow Advantage

For erosive applications, the recommended flow direction for the V500 valve is with the shaft upstream. High velocity flow is isolated in the port or outlet area. Here the seat ring and retainer can be protected by utilizing erosion-resistant materials and can be easily maintained.

Long-Life, Bi-Directional Seating

Both sides of the seat ring have a shutoff surface, allowing the ring to be flipped over to extend operating life. The seat ring self-centers, self-laps, and dynamically aligns with the plug, achieving bi-directional ANSI Class IV shutoff.

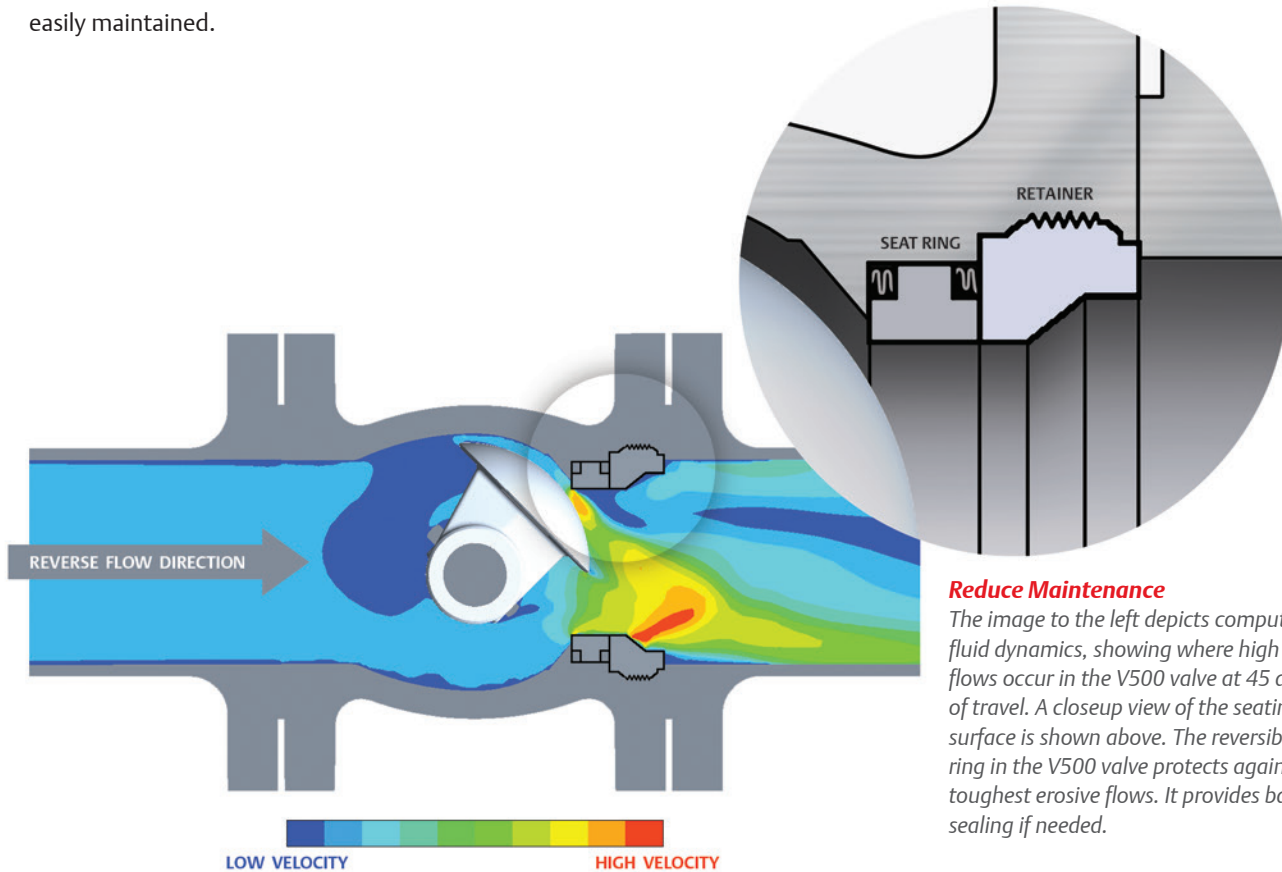

Reduce Maintenance

The image to the left depicts computational fluid dynamics, showing where high velocity flows occur in the V500 valve at 45 degrees of travel. A closeup view of the seating surface is shown above. The reversible seat ring in the V500 valve protects against the toughest erosive flows. It provides back-up sealing if needed.

Availability Overview

End Connection	Size NPS	ASME Class	EN Rating	Flow Characteristic	Flow Coefficient Ratio
Raised-Face Flanges	1–8	150/300/600	PN10–PN100	Modified Linear	100:1
Ring-Type Joint Flanges	1–8	150/300/600	PN10–PN100	Modified Linear	100:1
Flangeless (1)	3–8	150/300/600	PN10–PN100	Modified Linear	100:1



Complete specifications can be found in the V500 Product Bulletin. Scan or click the QR code to view it.

(1) CL600 not available in NPS 6 and 8 flangeless valve bodies.

Note: NACE constructions are available. Contact your Emerson local business partner or sales office regarding compliance with worldwide standards.

INCREASE AVAILABILITY WITH THE FISHER V500 ASSEMBLY

Body Construction Options

Full and restricted port trims for variable-flow applications provide operational versatility. Optional internal body coatings help withstand erosion and promote extended life. The V500 flanged body helps eliminate exposed line flange bolting, shorten alignment and installation time, and promote secure valve installations and piping integrity. The flangeless V500 body is self-centering on line bolting for easy installation.

Emissions Control

Available Fisher ENVIRO-SEAL™ packing system provides improved sealing and control of emissions compared to standard packing.

Selectable Trim

You can select trim materials for various erosive applications. The plug, seat ring, and retainer are available in four levels for a range of erosion resistance. See pages 6–7 for trim level details.

Bearing Options

Sealed metal bearings help prevent particle buildup and valve shaft seizure in erosive applications. High-temperature bearings are also available.

Rugged Construction

Eccentric plug action minimizes friction and seal wear. Durable metal or very tough ceramic (VTC) seat ring and valve plug shut off tightly without deforming plug arms or employing thin ball seals.

Reliable Actuator Performance

The 2052 spring-and-diaphragm actuator was designed for long operating life under load conditions. It has no O-rings to wear, inherent fail position on loss of air, low actuator pressures for operation, and double-sided diaphragms.

Precise Valve Positioning

The linkage-less, non-contact FIELDVUE DVC6200 digital valve controller is paired with the V500 valve to achieve precise positioning and fast response to process changes. With no linkage to wear, loosen, corrode, or vibrate, the FIELDVUE DVC6200 digital valve controller can handle harsh environments and nonstop cycling. It offers integral 4-20 mA position feedback for explosion-proof or non-explosion-proof applications.

Compact, High-Torque, Spring-and-Diaphragm Actuator

The 2052 actuator allows greater mounting versatility where space is at a premium.

Large Pressure Drop Without Windup

The large diameter, splined shaft with clamped actuator lever connection helps prevent lost motion while minimizing windup and allowing for large pressure drops. This configuration is ideal for accurate positioning and throttling control.

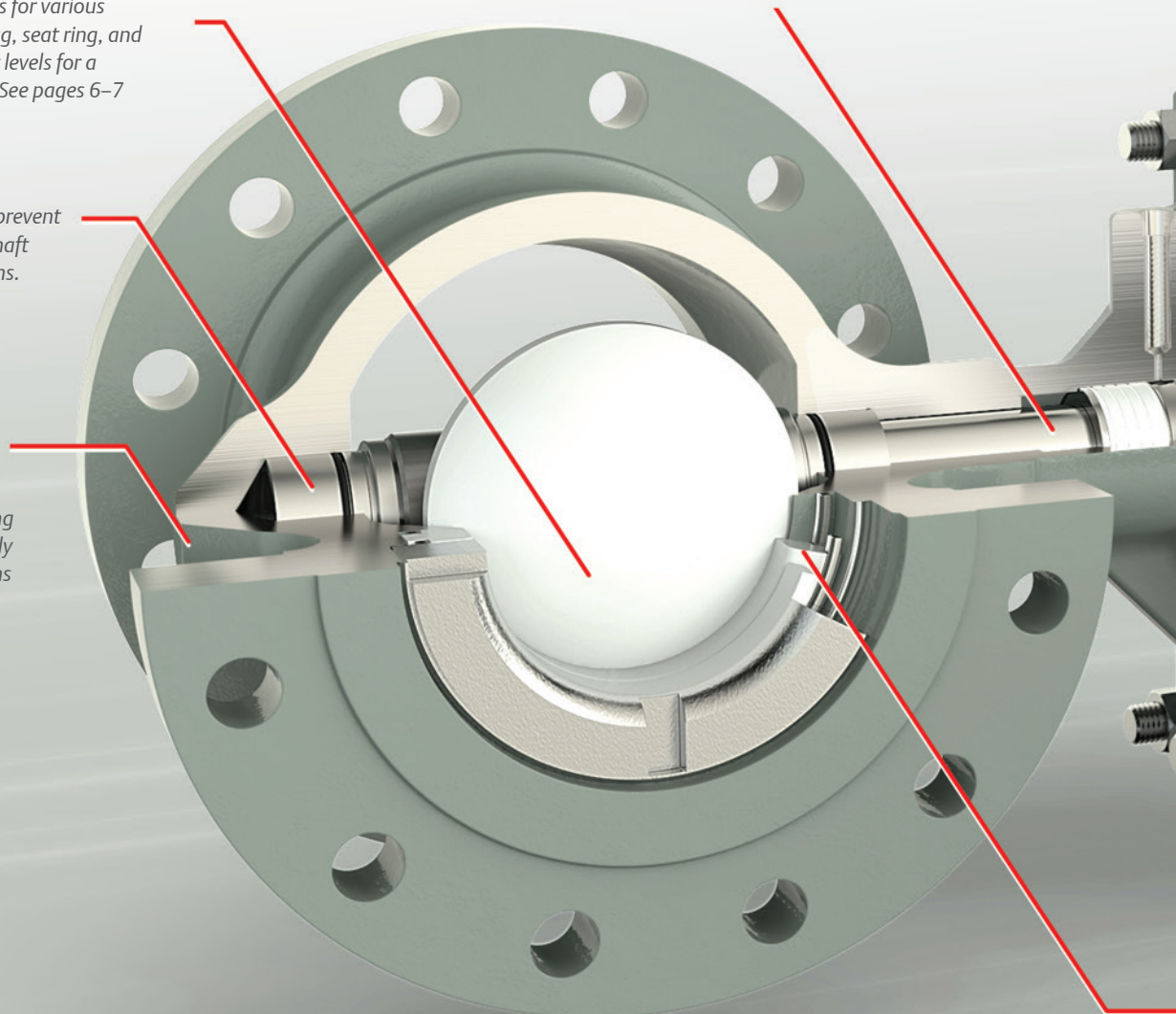

Fisher V500 control valve, 2052 actuator, and DVC6200 digital valve controller



No Sliding Parts to Wear

Modular construction of the DVC6200 digital valve controller provides auto-calibration and diagnostics technology. Linkage-less, non-contact feedback technology eliminates linkage wear and improves reliability.

Dual Packing Arrangements

Deep packing box allows for double, live-loaded packing arrangements. Packing is distanced from the process and allows access to lubricator or leakoff connections.

Self-Centering Ring

The seat ring allows Class IV shutoff in either flow direction. It is available in full or restricted port constructions and can be changed in conjunction to capacity requirements.

TRIM OPTIONS

TRIM LEVEL 4 utilizes VTC material for wear and corrosion resistance for your most erosive applications. VTC is a Fisher trade name for a particular grade of transformation-toughened ceramic known for being extremely rugged.

- Plug - Solid VTC or VTC surface cap
- Seat Ring - Solid VTC
- Retainer - R30006 (Alloy 6) or VTC

Typical applications for the V500 valve with trim level 4 include the dirtiest and most erosive flows such as bauxite slurry, lime mud underflow, catalyst cracker bottoms, water with entrained solids, mineral slurries, and heavy oil slurries.



TRIM LEVEL 3 includes an Alloy 6 plug, seat ring, and retainer for erosive services that require a metallic trim solution. It is meant for use in high-temperature, high-velocity fluids where ceramic materials are not suitable.

- Plug - R30006 (Alloy 6)
- Seat Ring - R30006 (Alloy 6)
- Retainer - R30006 (Alloy 6)

There is a high-temperature 3H configuration for applications over 316°C (600°F).

Typical applications for the V500 valve with trim level 3 include digester gas-off, ash handling, phosphate acid, low pressure heater drains, and reclamation water.

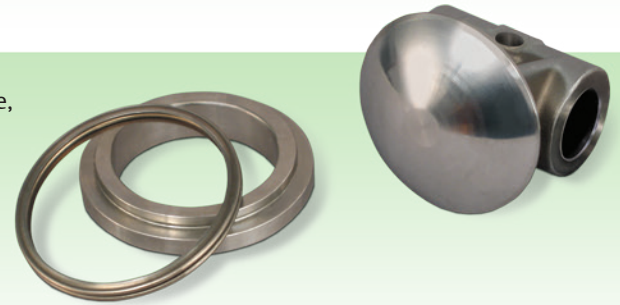

APPLICATION-SPECIFIC V500 DESIGNS

Applying valves to control the extraction or separation of bitumen from oil sands is a challenge because bitumen can be very erosive. A special V500 trim configuration is available and ideal for use in oil sands and refining applications to withstand erosive slurry services, helping extend operating life.

Typical applications include delayed coker heater feed valves and fluid catalytic cracking fractionator bottoms to reactor valves. For more information about this trim option or other available configurations, contact your Emerson local business partner or sales office.



TRIM LEVEL 2 is great for general service, high-pressure applications with an Alloy 6 plug and seat ring, and stainless steel retainer.

- Plug - R30006 (Alloy 6) or 318SST with CoCr-A faced*
- Seat Ring - Alloy 6
- Retainer - 316 SST or 17-4PH SST

Typical applications for the V500 valve with trim level 2 include soot blower, geothermal, crude oil emulsion, and molybdenum slurry.

TRIM LEVEL 1 is for general service applications where excess wear is occurring in the trim or body. Chrome plated plug, stainless steel seat ring, and retainer are utilized.

- Plug - 316 SST with chrome plate
- Seat Ring - 316 SST
- Retainer - 316 SST or 17-PH SST

Typical applications for the V500 valve with trim level 1 are generally standard processes with maintenance issues due to trim wear.

* Some trim materials are only available with certain NPS sizes. For more information, contact your Emerson local business partner or sales office.

CUSTOMER PROVEN RESULT

- **APPLICATION:** Recausticizing unit in a pulp mill.
- **CHALLENGE:** Erosive lime mud washed out the trim and body of an NPS 3 plug valve with standard trim (316L/Stellited plug, 316 seat ring) every four to six weeks. Cost of repair was \$5,000 USD every six weeks.
- **SOLUTION:** NPS 3 Fisher V500 valve with stainless steel body and trim level 4 operating in the reverse flow direction.
- **RESULTS:** After five months of service, valve diagnostics revealed that the Fisher V500 valve is in “like new” condition. Improved reliability allows better operation and reduced maintenance costs of \$17,000 USD. The customer now avoids additional production losses due to downtime caused by the previous valve.

CUSTOMER PROVEN RESULT

- **APPLICATION:** Flash tank valves in a power plant.
- **CHALLENGE:** The original ball valve had to be repaired and replaced every six months. This was due to the flashing service and the valve was also oversized. Cost of repair or replacement was \$3,500 to \$7,000 USD. The customer needed to increase the life and performance of valve in the application.
- **SOLUTION:** Fisher V500 valve with trim level 3 with a reduced port for better control.
- **RESULTS:** After 12 months, the Fisher V500 valve is providing better control and performance.

CUSTOMER PROVEN RESULT

- **APPLICATION:** Diluted bitumen furnace feed valves.
- **CHALLENGE:** The demanding process of extracting bitumen from sand caused frequent, unplanned maintenance on several furnace charge valves. Every three to four months, the customer shut down the process and replaced valve trim due to excessive erosion.
- **SOLUTION:** Fisher V500 valves with specially-configured trim.
- **RESULTS:** Fisher V500 valves have extended time between unit turnarounds, improved process control, and reduced the cost of maintenance.

Choice of Construction Materials

One of the advantages of the Fisher V500 valve is its ability to adapt to tough applications and help you increase plant availability. The key to this adaptation is the availability of four standard trim levels to fit your hard-to-handle applications. Each trim level is built to withstand different degrees of erosive, dirty, or abrasive processes. Changing to a higher or tougher trim level or adding an internal body coating may help to increase your valve’s operating life. To find out if there is an opportunity to increase your plant availability, contact an Emerson local business partner or sales office.

V500 Valve Fluid Compatibility Guidelines

Erosive	Dirty	Clean	Viscous	Corrosive	Fibrous Slurry
A	A	A	B	B	C

A = Best choice. Highly suited to this type of service.

B = Good choice. May require the use of options for enhanced performance.

C = Not recommended for this service.

Fisher Control Valve Lifecycle Services

The way you manage key production assets like control valves directly affects your plant's efficiency, reliability, and profitability. Emerson's Fisher Services provides trusted expertise for reliability-centered control valve maintenance and repair.

Whether you're starting or commissioning a process, scheduling diagnostics and repair, or planning a turnaround with upgrades to optimize and extend your plant's lifecycle, our global network of owned and authorized service centers provide effective maintenance through experienced, highly skilled technicians when and where you need them.

To help you maintain your plant's efficiency and reliability, Fisher Services uses only certified OEM parts and assemblies sourced through local inventories, regional parts distribution centers, and Quick Ship facilities to deliver unmatched response to customer needs.

With Emerson's Fisher Services as your trusted partner, you can realize the true potential of your Fisher and non-Fisher control valves throughout their lifecycle.

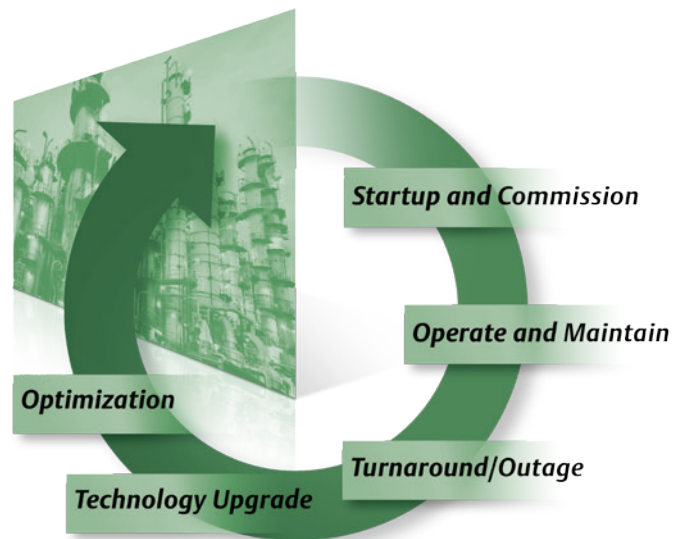

 <http://www.Facebook.com/FisherValves>

 <http://www.Twitter.com/FisherValves>

 <http://www.YouTube.com/user/FisherControlValve>

 <http://www.Linkedin.com/groups/Fisher-3941826>

To find the Fisher sales contact in your area, scan or click the QR code.



© 2013 Fisher Controls International LLC. All rights reserved.

Fisher, FIELDVUE, and ENVIRO-SEAL are marks owned by one of the companies in the Emerson Process Management business unit of Emerson Electric Co. Emerson Process Management, Emerson, and the Emerson logo are trademarks and service marks of Emerson Electric Co. All other marks are the property of their respective owners.

The contents of this publication are presented for informational purposes only, and while every effort has been made to ensure their accuracy they are not to be construed as warranties or guarantees, express or implied, regarding the products or services described herein or their use or applicability. All sales are governed by our terms and conditions, which are available upon request. We reserve the right to modify or improve the designs or specifications of such products at any time without notice. Neither Emerson, Emerson Process Management, nor any of their affiliated entities assumes responsibility for the selection, use, or maintenance of any product. Responsibility for proper selection, use, and maintenance of any product remains solely with the purchaser and end user.

Emerson Process Management

Marshalltown, Iowa 50158 USA
Sorocaba, 18087 Brazil
Chatham, Kent ME4 4QZ UK
Dubai, United Arab Emirates
Singapore 128461 Singapore
www.Fisher.com

