

Fisher® 2052 Diaphragm Rotary Actuator

Contents

Introduction	1
Scope of Manual	1
Description	1
Specifications	3
Installation	4
Actuator Mounting	5
Maintenance	7
Replacing Diaphragm	8
Replacing Diaphragm Plate, Diaphragm Rod Assembly, and Spring(s)	9
Changing Or Replacing Actuator Lever	11
Positioner Mounting (3610 or DVC6020)	12
Top-Mounted Handwheel	12
Locking Mechanism	13
Parts Ordering	17
Parts List	17

Figure 1. Fisher Control-Disk™ Valve with 2052 Actuator and DVC6200 Digital Valve Controller



W9425-2

Introduction

Scope of Manual

This instruction manual includes installation, adjustment, operation, maintenance, and parts information for the Fisher 2052 diaphragm rotary actuator (figure 1). Instructions for the control valve, positioner, manual actuator, and other accessories are included in separate manuals.

Do not install, operate, or maintain a 2052 actuator without being fully trained and qualified in valve, actuator, and accessory installation, operation and maintenance. To avoid personal injury or property damage, it is important to carefully read, understand, and follow all the contents of this manual, including all safety cautions and warnings. If you have any questions about these instructions, contact your Emerson Process Management sales office before proceeding.

Description

2052 spring-and-diaphragm rotary actuators are used on rotary-shaft valve bodies for throttling or on-off applications. The 2052 may be used for on-off service without a positioner, or it may be used for throttling service with a positioner, depending on service conditions. The 2052 has an ISO 5211 mating interface that allows installation to non-Fisher valves. Refer to separate bulletins for valve and positioner information.



A top-mounted handwheel option is available for infrequent service as a manual actuator. For repeated or daily manual operation, the unit should be equipped with a side-mounted declutchable 1078 manual actuator. Externally adjustable travel stops are used to limit the degree of rotation at both ends of the actuator stroke.

The lever for the 2052 actuator is supported by bushings. The lever may be changed to accommodate valve bodies with different size valve shafts.

Table 1. Fisher 2052 Actuator Specifications

Specifications	
Actuator Mounting Connections	Splined shaft connection, ISO 5211 actuator-to-bracket connection Size 1: F07, Size 2: F10, Size 3: F14
Actuator Sizes	See table 2
Operating Pressure ⁽¹⁾	See table 3
Maximum Diaphragm Casing Pressure	Size 1, 2, and 3 Actuators: 5 barg (73 psig)
Pressure Connection	See table 4
Torque Output	See table 3
Actuator Temperature Capabilities ⁽¹⁾	-45 to 80°C (-50 to 176°F)
Operation	Field reversible between PDTTC and PDTO; right- and left-hand mounting, any angle of orientation
Approximate Weight	Size 1: 22.2 kg (49 lb) Size 2: 54.4 kg (120 lb) Size 3: 113 kg (250 lb)
Controller/Positioners Available	DVC2000, DVC6020, DVC6030, DVC6200, 3610J, 3620J, 4190, C1
Accessories Available	846, 646, 2625, and 67C Series, switches, i2P-100, VBL, DXP, GO™
Handwheel	Top-mounted handwheel: Optional on Size 1 and 2 actuators only Declutchable handwheel: Optional on Size 1, 2, and 3 actuators
Operational Lockout	Available for customer-supplied padlock to lock the actuator in the spring-fail position

1. The pressure/temperature limits in this manual should not be exceeded.

Table 2. Actuator and Shaft Size Availability

SHAFT SIZE Inches	ACTUATOR SIZE		
	1	2	3
1/2	available	not available	not available
5/8	available	available	not available
3/4	available	available	available
1	not available	available	available
1-1/4	not available	available	available
1-1/2	not available	not available	available
1-3/4	not available	not available	available
2	not available	not available	available

Table 3. Torque versus Actuator Size

ACTUATOR SIZE AND ACTION	OPERATING PRESSURE			
	2 barg (29 psig) ⁽¹⁾		4 barg (58 psig) ⁽²⁾	
	Torque		Torque	
	N•m	lbf•in	N•m	lbf•in
1 (PDTO, PDTTC)	25.5	226	51.2	453
2 (PDTO, PDTTC)	105	930	210	1860
3 (PDTO)	327	2890	631	5583
3 (PDTTC)	280	2479	584	5173

1. Operating pressure up to 3 barg (44 psig) is allowable for single spring construction.

2. Operating pressure up to 5 barg (73 psig) is allowable for dual spring construction.

Table 4. Pressure Connections

ACTUATOR SIZE	PRESSURE CONNECTION			
	1/4 NPT	1/2 NPT	3/4 NPT	G 1/4
1	standard	optional	not available	optional
2	standard	optional	not available	optional
3	not available	standard	optional	not available

Table 5. Fisher 2052 Actuator Mounting Styles

MOUNTING	ACTION(1)	VALVE SERIES OR DESIGN			VALVE SERIES OR DESIGN	
		BALL/PLUG ROTATION TO CLOSE	V150, V200 & V300	CV500 V500	DISK/BALL ROTATION TO CLOSE	A11, 8510B, 8532, 8560, 8580, 9500, and Control-Disk Valve
Right-Hand	PDTC	CCW	A	A	CW	B
	PDTO	CCW	B	B	CW	A
Left-Hand	PDTC	CCW	D	D	CW	C
	PDTO	CCW	C	C	CW	D
Left-Hand (Optional)(2)	PDTC	CW	C	NA	NA	NA
	PDTO	CW	D	NA	NA	NA

1. PDTC—Push-down-to-close, and PDTO—Push-down-to-open.
 2. A left hand mounted ball will be required for the NPS 3 through 12 Vee-Ball Series B and the NPS 14 and 16, with or without attenuator.

Figure 2. Fisher 2052 Actuator Mounting Styles

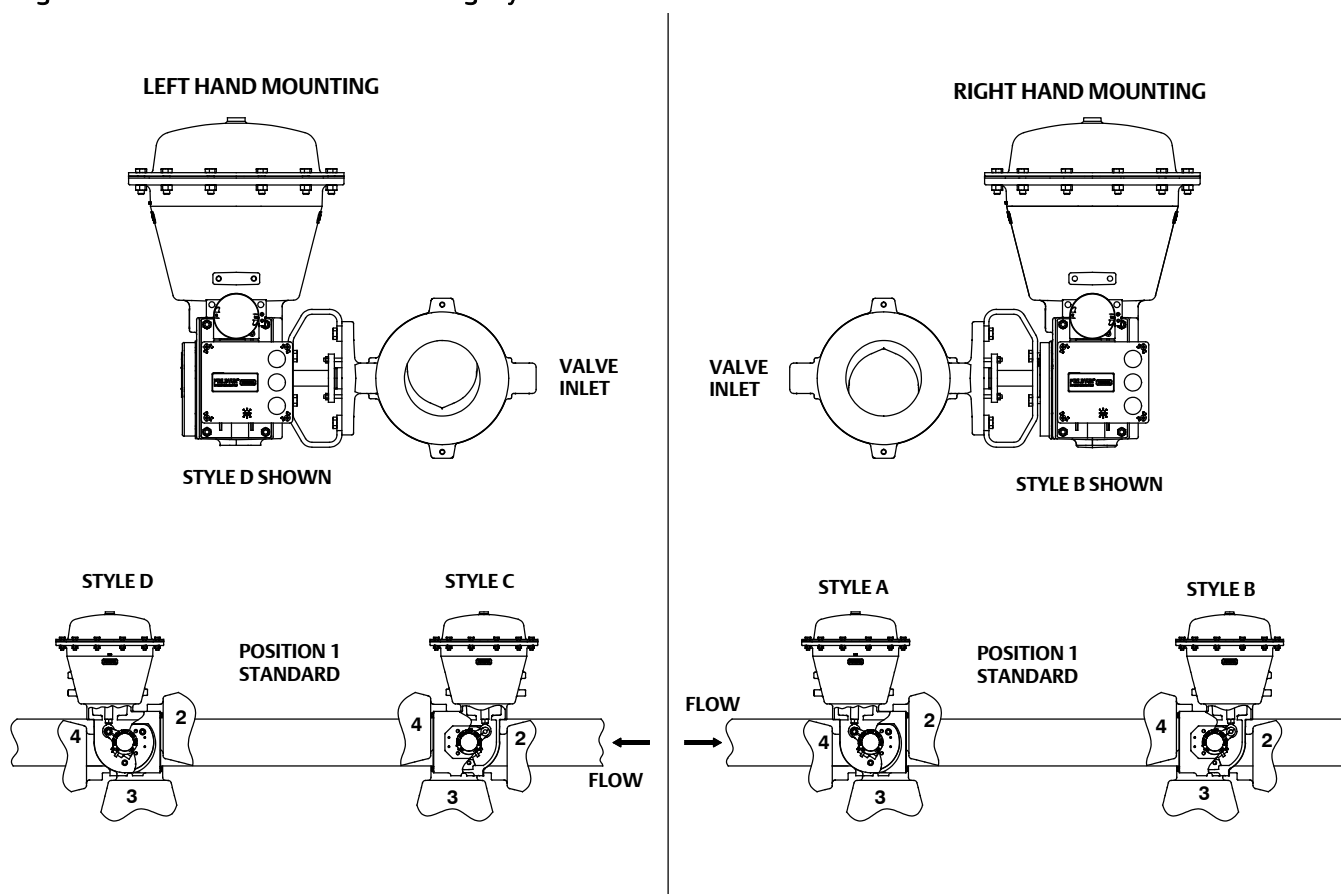

Specifications

Specifications are shown in table 1 for 2052 actuators. Specifications for actuator operation are stamped on a metal nameplate attached to the actuator.

Table 6. Bolting Torque Requirements⁽¹⁾

DESCRIPTION KEY NUMBER	ACTUATOR SIZE	TORQUE		FASTENER LUBRICATION
		N•m	Lbf•ft	
Rod End Bearing Clamping Bolt Torque, Key 16	1	38	28	None
	2	180	130	
	3	400	295	
End Plate to Housing Bolt Torque, Key 4	1	68	50	None
	2	120	90	
	3	210	155	
Diaphragm Plate to Rod Bolt Torque, Key 7	1	27	20	Anti-Seize Lubricant
	2	115	85	
	3	300	220	
Casing Bolt Torque, Key 8	1	55	40	None
	2	55	40	
	3	55	40	
Housing to Yoke Bolt Torque, Key 28	1	27	20	None
	2	68	50	
	3	245	180	
Lever-Spline Clamping Bolt Torque, Key 15	1	38	28	None
	2	115	85	
	3	175	130	
Optional Lockout Kit Mounting Bolt Torque, Key 53	1	NA	NA	None
	2	88	65	
	3	340	250	

1. Exceeding any torque requirements could damage the actuator and impair safe operation.

Installation

⚠ WARNING

Always wear protective gloves, clothing, and eyewear when performing any installation operations.

Check with your process or safety engineer for any other hazards that may be present from exposure to process media.

If installing into an existing application, also refer to the WARNING at the beginning of the Maintenance section in this instruction manual.

CAUTION

To avoid parts damage, do not apply pressure that exceeds the Maximum Diaphragm Casing Pressure in table 1. Use pressure-limiting or pressure-relieving devices to prevent the Operating Pressure from exceeding the values shown in table 3.

The actuator, as it comes from the factory, is normally mounted on a valve body. If the actuator is shipped separately or if it is necessary to mount the actuator on the valve, perform the procedures presented in the Actuator Mounting section. Follow the procedures given in the valve instruction manual when installing the control valve in the pipeline.

If a positioner is ordered with the actuator, the pressure connection to the actuator is normally made at the factory. If it is necessary to make this connection, run tubing of the appropriate size for the diaphragm casing pressure connection (reference table 4) between the pressure connection and the instrument. Keep the length of tubing or pipe as short as possible to avoid transmission lag in the control signal.

When the control valve is completely installed and connected to the controlling instrument, check to make sure that the action is correct (air-to-open or air-to-close) and that the controlling instrument is properly configured for the

desired action. For successful operation, the diaphragm rod assembly, lever, and valve shaft must move freely in response to changes in the loading pressure on the diaphragm.

Actuator Mounting

⚠ WARNING

Avoid personal injury or property damage from sudden release of process pressure or bursting of parts. Before performing any maintenance operations:

- Do not remove the actuator from the valve while the valve is still pressurized.
 - Always wear protective gloves, clothing, and eyewear when performing any maintenance operations.
 - Disconnect any operating lines providing air pressure, electric power, or a control signal to the actuator. Be sure the actuator cannot suddenly open or close the valve.
 - Use bypass valves or completely shut off the process to isolate the valve from process pressure. Relieve process pressure from both sides of the valve. Drain the process media from both sides of the valve.
 - Safely vent the power actuator loading pressure.
 - Use lock-out procedures to be sure that the above measures stay in effect while you work on the equipment.
 - The valve packing box may contain process fluids that are pressurized, *even when the valve has been removed from the pipeline*. Process fluids may spray out under pressure when removing the packing hardware or packing rings.
 - Check with your process or safety engineer for any hazards that may be present from exposure to process media.
-

Use the following steps to mount the actuator or to change actuator mounting style or position.

Unless otherwise specified, key numbers referenced in the following procedures are shown in figure 7 for the 2052 actuator.

If the Actuator is mounted on a valve body and it is necessary to change mounting style or position, the actuator must first be separated from the valve body.

1. Isolate the valve body from the process. Release process pressure and vent all actuator pressure.
2. Remove the cover or plug (key 2).

⚠ WARNING

To avoid personal injury and equipment damage from moving parts, keep fingers and tools clear while stroking the actuator with the cover removed.

3. Loosen the cap screw (key 15).
4. Separate the actuator from the valve body by removing the cap screws and nuts which secure the valve to the mounting yoke (key 27). Proceed to step 5.

If the actuator is not mounted on a valve body ensure the up and down travel stops (see figure 3) are adjusted correctly to achieve the desired actuator rotation. Use the travel indicator (key 21) and travel scale (key 19) as reference.

Note

Once each travel stop is properly positioned, adequately tighten the hex nut (key 24) to lock the travel stop in place.

5. Refer to figure 2 and table 5 for available mounting styles and positions. The actuator is normally positioned vertically with the valve in a horizontal pipeline.
6. Determine whether the actuator mounting yoke (key 27) will be mounted on the end plate assembly (key 3) side or on the actuator housing boss side of the actuator. If the desired mounting position and style require moving the mounting yoke (key 27) and travel indicator components to opposite sides of the actuator, remove the machine screws (keys 20 and 22), the travel indicator scale (key 19), and the travel indicator (key 21). Remove the cap screws (key 28) and the mounting yoke (key 27). Install the mounting yoke in the desired position (on the end plate assembly or on the actuator housing boss). Tighten the mounting cap screws to the torque specified in table 6. Install the travel indicator components on the opposite side of the actuator.

▲ WARNING

To avoid personal injury or property damage, ensure the travel indicator is installed correctly to coincide with the desired actuator action. Refer to figure 3 for more information.

Figure 3. Fisher 2052 Actuator Travel Stops and Travel Indication

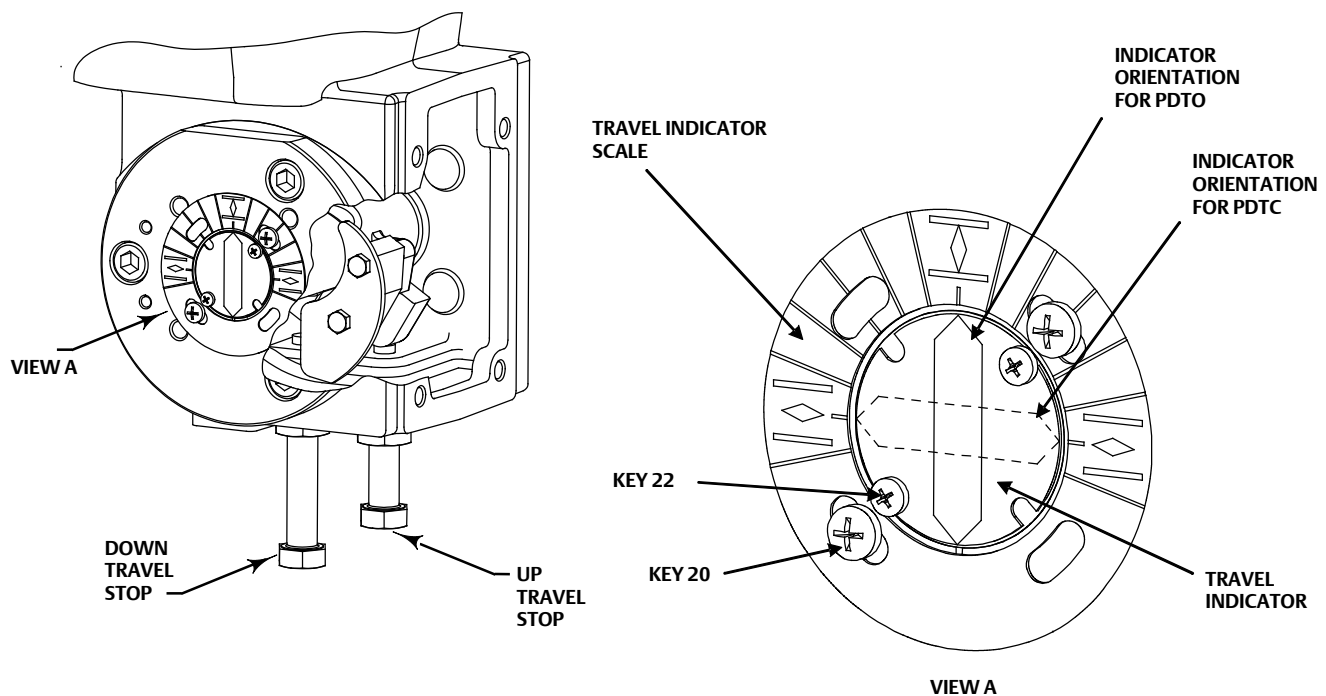

7. Before sliding the valve shaft into the lever, position the valve ball or disk as follows:

For push-down-to-close action, the valve ball or disk should be in the fully open position.

For push-down-to-open action, the valve ball or disk should be in the fully closed position (see the valve body instruction manual).

8. Make sure that the index markings on the valve shaft are properly aligned with either the markings on the lever or the travel indicator scale mounting holes. Slide the valve shaft into the lever. (See figure 4 for one possible orientation.) Install the valve mounting cap screws and nuts. Tighten to the torque value given in the appropriate valve body instruction manual.

9. Ensure all end play in the valve shaft is removed by directing the valve shaft and control element toward the actuator as much as possible.
10. Tighten the socket head cap screw (key 15) which compresses the splined lever connection to the valve shaft (see table 6). Install the cover or plug (key 2) into the access hole in the housing.

CAUTION

When adjusting the travel stop for the closed position of the valve ball or disk, refer to the appropriate valve instruction manual for detailed procedures. Undertravel or overtravel at the closed position may result in poor valve performance and/or damage to the equipment.

11. Adjust the up travel stop (see figure 3) so that the valve ball or disk is in the desired position. When adjusting the up travel stop, ensure the stop is not backed out too far, causing the lever to over-rotate. Over-rotation of the lever may cause damage to valve components. Avoid over-rotation by adjusting the up travel stop so that the travel indicator screws (key 22) align with the travel scale screws (key 20). See figure 3.
12. Stroke the actuator and adjust the down travel stop so that the valve ball or disk is in the desired position.

Note

Once each travel stop is properly positioned, adequately tighten the hex nut (key 24) to lock the travel stop in place.

13. Make sure that the travel indicator pointer matches the ball or disk position. Remove and install in the proper position if necessary.
14. Refer to the table of contents for accessory installation procedures.

Maintenance

Actuator parts are subject to normal wear and must be inspected and replaced as necessary. The frequency of inspection and replacement depends upon the severity of service conditions. Instructions are given below for disassembly and assembly of parts. Key numbers referenced in the following steps are shown in figure 7 for the 2052, except as listed below or otherwise specified in the procedures.

⚠ WARNING

Avoid personal injury or property damage from sudden release of process pressure or bursting of parts. Before performing any maintenance operations:

- Do not remove the actuator from the valve while the valve is still pressurized.
- Always wear protective gloves, clothing, and eyewear when performing any maintenance operations.
- Disconnect any operating lines providing air pressure, electric power, or a control signal to the actuator. Be sure the actuator cannot suddenly open or close the valve.
- Use bypass valves or completely shut off the process to isolate the valve from process pressure. Relieve process pressure from both sides of the valve. Drain the process media from both sides of the valve.
- Safely vent the power actuator loading pressure.
- Use lock-out procedures to be sure that the above measures stay in effect while you work on the equipment.

- Check with your process or safety engineer for any hazards that may be present from exposure to process media.

Replacing Diaphragm

Isolate the valve body from the process. Release process pressure and vent all actuator pressure.

Disassembly

1. Remove the supply tubing or pipe from the top casing assembly (key 5).

⚠ WARNING

To avoid personal injury from precompressed spring force suddenly thrusting parts away from the actuator, spring compression must first be relieved. Closely follow the instructions below.

Figure 4. Orientation of the Fisher 2052 Actuator Lever into the Housing and Aligning the Actuator to the Valve Shaft Markings

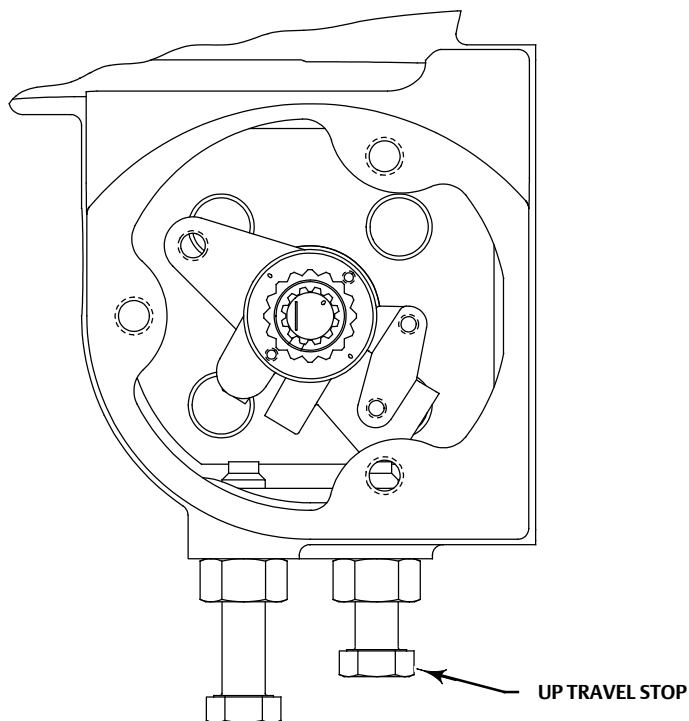

2. Loosen, but do not remove, all casing cap screws and hex nuts (keys 8 and 9). Ensure there is no spring force to the top casing assembly (key 5). If spring force is detected against the top casing assembly, ensure the up travel stop cap screw (key 23) is adjusted correctly to prevent over-rotation of the lever (key 14). Refer to figure 3. The travel indicator screws (key 22) in the end of the lever should be in alignment with the travel scale screws (key 20). If the up travel stop is confirmed to be adjusted correctly and force is still detected against the top casing assembly,

contact your local Emerson Process Management Instrument and Valves Service Center. Alternatively, replace two oppositely located casing cap screws (key 8) with 100 mm (4 inch) long fully threaded M10 cap screws of ISO 898-1 Property Class 8.8 material or equivalent. Loosen the nuts (key 9) on the two fasteners in an equivalent manner to relieve spring force.

3. Carefully remove all cap screws and hex nuts (keys 8 and 9) from the top casing assembly. The spring forces are retained by the diaphragm rod assembly (key 10), allowing quick removal of the pressure retaining components.
4. Remove the top casing assembly and the diaphragm (key 11).
5. Inspect the diaphragm plate (key 6). If the diaphragm plate is damaged or if further disassembly of the actuator is required, proceed to the Replacing Diaphragm Plate, Diaphragm Rod Assembly, and Spring(s) procedure.
6. Inspect the diaphragm and replace if necessary.

Assembly

1. Place the diaphragm (key 11) on the diaphragm plate (key 6), making certain that it is properly centered.
2. Observe the correct position of the loading connection fitting and install the top casing assembly (key 5). Replace the cap screws and nuts (keys 8 and 9) which secure the top casing assembly to the actuator housing. Tighten the nuts in an alternating fashion (see table 6).
3. Install the inlet piping to the top casing assembly.

Replacing Diaphragm Plate, Diaphragm Rod Assembly, and Spring(s)

Isolate the valve body from the process. Release process pressure and vent all actuator pressure.

Disassembly

1. Remove the supply tubing or pipe from the top casing assembly (key 5).

⚠ WARNING

To avoid personal injury from precompressed spring force suddenly thrusting parts away from the actuator, spring compression must first be relieved. Closely follow the instructions below.

2. Loosen, but do not remove, all casing cap screws and hex nuts (keys 8 and 9). Ensure there is no spring force to the top casing assembly (key 5). If spring force is detected against the top casing assembly, ensure the up travel stop cap screw (key 23) is adjusted correctly to prevent over-rotation of the lever (key 14). Refer to figure 3. The travel indicator screws (key 22) in the end of the lever should be in alignment with the travel scale screws (key 20). If the up travel stop is confirmed to be adjusted correctly and force is still detected against the top casing assembly, contact your local Emerson Process Management Instrument and Valves Service Center. Alternatively, replace two oppositely located casing cap screws (key 8) with 100 mm (4 inch) long fully threaded M10 cap screws of ISO 898-1 Property Class 8.8 material or equivalent. Loosen the nuts (key 9) on the two fasteners in an equivalent manner to relieve spring force.
3. Carefully remove all cap screws and hex nuts (keys 8 and 9) from the top casing assembly. The spring forces are retained by the diaphragm rod assembly (key 10), allowing quick removal of the pressure retaining components.
4. Remove the top casing assembly and the diaphragm (key 11).
5. Inspect the diaphragm plate (key 6).
 - a. To relieve spring compression, using a hex wrench, unscrew and remove the socket head cap screw (key 7) which secures the diaphragm plate (key 6) to the diaphragm rod assembly (key 10). Remove the diaphragm plate.
6. Remove the spring (key 13) or springs (keys 12 and 13).

7. The guide assembly (key 48) may be removed for inspection (size 3 only).

Note

At this stage of disassembly, it may be determined that further disassembly is not necessary. If separation of the diaphragm rod assembly from the lever is not warranted, proceed to the Assembly portion within this section of the procedure.

8. To gain access to the cap screw (key 16) which secures the diaphragm rod assembly to the lever, the end plate assembly (key 3) must be removed. Before the end plate assembly can be removed, one of the following procedures must be performed. Proceed as appropriate:
 - **For actuators with valve bodies mounted on the end plate assembly (key 3) side of the actuator**, the actuator must be separated from the valve body. Perform steps 1 through 4 of the Actuator Mounting section, remove the mounting yoke (key 27), and then return to step 9 of this section.
 - **For actuators with valve bodies mounted on the actuator housing boss side of the actuator [opposite of the endplate (key 3)]**, remove the travel indicator pointer (key 21). Proceed to step 9.
9. Remove the socket head cap screws (key 4) and the end plate assembly (key 3).
10. Remove the cap screw (key 16) and nut (key 17) if applicable (size 3 only), that secures the actuator lever (key 14) to the diaphragm rod assembly (key 10). Remove the diaphragm rod assembly.
11. Inspect all parts and replace if necessary.
12. If total disassembly of the actuator is required, or if the actuator will be assembled for use with a valve body with a different valve shaft diameter, proceed to the Changing or Replacing Actuator Lever procedure.

Assembly

1. Fasten the diaphragm rod assembly (key 10) to the lever using the cap screw (key 16) and nut (key 17) if applicable. Tighten per table 6.
2. Install the housing end plate (key 3).
3. Adjust the travel stop bolts to the correct position so that the travel indicator screws (key 22) align with the travel scale screws (key 20). See figure 3.
4. Install the guide assembly (key 48 - size 3 only).
5. Install the spring(s). The outer (larger diameter) spring is standard for the single spring size 1 & 2 constructions. The inner spring is standard for the single spring size 3 construction.
6. Place the diaphragm plate (key 6) onto the spring(s). It is important that the springs be properly seated in their respective counterbores on the bottom side of the plate. If necessary, push or pull the diaphragm plate toward center to ensure the springs are engaged into their respective seats.
7. Lubricate the socket head capscrew (key 7) and tighten per table 6.
8. Place the diaphragm (key 11) on the diaphragm plate (key 6), making certain that it is properly centered.
9. Observe the correct position of the loading connection fitting and install the top casing assembly (key 5). Replace the cap screws and nuts (keys 8 and 9) which secure the top casing assembly to the actuator housing. Tighten the nuts in an alternating fashion (see table 6).
10. Install the inlet piping to the top casing assembly.
11. Install the travel indicator (key 19) if removed.
12. If the actuator was removed from the valve body, refer to the appropriate section in the Actuator Mounting procedure and proceed as applicable.

Changing or Replacing Actuator Lever

⚠ WARNING

Avoid personal injury or property damage. The end plate assembly (key 3) and lever (key 14) may only be removed after the actuator spring compression forces are safely relieved. Refer to the instructions below.

Disassembly

⚠ WARNING

Avoid personal injury or property damage from sudden release of process pressure or bursting of parts. Before performing any maintenance operations:

- Do not remove the actuator from the valve while the valve is still pressurized.
- Always wear protective gloves, clothing, and eyewear when performing any maintenance operations.
- Disconnect any operating lines providing air pressure, electric power, or a control signal to the actuator. Be sure the actuator cannot suddenly open or close the valve.
- Use bypass valves or completely shut off the process to isolate the valve from process pressure. Relieve process pressure from both sides of the valve. Drain the process media from both sides of the valve.
- Safely vent the power actuator loading pressure.
- Use lock-out procedures to be sure that the above measures stay in effect while you work on the equipment.
- Check with your process or safety engineer for any other hazards that may be present from exposure to process media.

1. Isolate the valve body from the process. Release process pressure and vent all actuator pressure.
2. Remove the cover or plug (key 2).

⚠ WARNING

To avoid personal injury and equipment damage from moving parts, keep fingers and tools clear while stroking the actuator with the cover removed.

3. Loosen the cap screw (key 15).
4. Follow steps 2 through 10 in the Replacing Diaphragm Plate, Diaphragm Rod Assembly, and Spring(s) section.
5. Remove and inspect the lever (key 14). If the lever is worn or damaged, or if the actuator will be mounted to a valve body requiring a different size lever, replace the lever.
6. Inspect the bushings located in the end plate (key 3) and housing (key 1) assemblies. If bushings are excessively worn or damaged, remove them with a press. Press in new bushings so that they are flush with the exterior surfaces of the actuator housing and the end plate assembly.

Assembly

1. Refer to figure 4 for the correct orientation of the lever during assembly.
2. If a cam-operated positioner is used, install the cam to the lever with the parts provided by the appropriate instrument mounting kit. Be sure to observe the orientation shown in figure 4 and follow all procedures given in the positioner instruction manual.

3. Insert the lever into the bushing in the actuator housing.
4. Fasten the rod end bearing diaphragm rod assembly to the lever using the cap screw (key 16) and nut (key 17) if applicable. Tighten per table 6.
5. Install the end plate assembly (key 3).
6. Adjust the travel stop bolts to the correct position so that the travel indicator screws (key 22) align with the travel scale screws (key 20). See figure 3.
7. Install the guide assembly (key 48) size 3 only.
8. Install the spring(s). The outer (larger diameter) spring is standard for the single spring size 1 & 2 constructions. The inner spring is standard for the single spring size 3 construction.
9. Place the diaphragm plate (key 6) onto the spring(s). It is important that the springs be properly seated in their respective counterbores on the bottom side of the plate. If necessary, push or pull the diaphragm plate toward center to ensure the springs are engaged into their respective seats.
10. Lubricate the socket head capscrew (key 7) and tighten per table 6.
11. Place the diaphragm (key 11) on the diaphragm plate (key 6), making certain it is properly centered.
12. Observe the correct position of the loading connection fitting and install the top casing assembly (key 5). Replace the cap screws and nuts (keys 8 and 9) which secure the top casing assembly to the actuator housing. Tighten the nuts in an alternating fashion (see table 6).
13. Install the inlet piping to the top casing assembly.
14. Refer to the Actuator Mounting procedure and proceed as applicable:

Positioner Mounting (3610, DVC6020, or DVC6200)

1. Before installing the positioner, the positioner cam must be installed on the lever.
2. Refer to assembly step 2 in the previous section on Changing or Replacing Actuator Lever.
3. Refer to the positioner instruction manual for setup and calibration procedures.

Top-Mounted Handwheel (Size 1 and 2)

Key numbers used in this procedure are shown in figure 9 except where indicated.

The optional top-mounted handwheel can be used as a manual actuator for intermittent service. It is not to be used as an adjustable travel stop. This is built into the housing.

The handwheel assembly is welded to a special top casing assembly (key 5, figure 9). A hex nut (key 43) locks the handwheel in position. For field installation of a handwheel, the special upper diaphragm casing is supplied with the handwheel.

Turning the handwheel (key 32) clockwise into the upper casing forces the pusher plate (key 36) against the diaphragm and diaphragm plate (keys 11 and 6, figure 7) to compress the inner and outer springs (keys 12 and 13, figure 7) and move the diaphragm rod assembly downward. Turning the handwheel counter-clockwise allows the actuator spring(s) to move the diaphragm rod assembly upward.

Instructions are given below for complete disassembly and assembly required for inspection and parts replacement.

Disassembly

WARNING

To avoid personal injury from the precompressed spring force thrusting the upper diaphragm casing away from the actuator, fully turn the handwheel counterclockwise.

1. Perform steps 1 through 6 of the Replacing Diaphragm procedure.
2. Remove the cotter pin, hex nut, handwheel, and locknut (keys 34, 33, 32, and 43). Unscrew the stem (key 35) out through the actuator end of the handwheel body (key 5).
3. Check the condition of the O-ring (key 44); replace if necessary.
4. If it is necessary to remove the pusher plate or spacer (key 36 or 42), drive out the groove pin (key 37).

Assembly

1. Before assembling, lubricate the thread of the stem (key 35) with anti-seize lubricant. Lubricate the bearing surfaces of the stem and rounded end with lithium grease.
2. If the pusher plate or spacer was removed, attach them to the stem and drive in a new groove pin (key 37).
3. With the O-ring (key 44) in place, thread the stem into the handwheel assembly.
4. Install the locknut, handwheel, hex nut, and cotter pin (keys 43, 32, 33, and 34).

Note

Be sure to install the handwheel so that the arrow of operation on the top side coincides with the action of the actuator, as stated on the nameplate. (The arrow should point clockwise for PDT0. The arrow should point counter-clockwise for PDTc.)

5. Install the top casing assembly, making certain the warning tag is in place on the casing flange.

Locking Mechanism

Refer to figures 5 or 6 for the appropriate size locking mechanism when installing or planning to operate the device.

⚠ WARNING

Avoid personal injury or property damage from sudden release of process pressure or bursting of parts. Before performing any maintenance operations:

- Do not remove the actuator from the valve while the valve is still pressurized.
 - Always wear protective gloves, clothing, and eyewear when performing any maintenance operations.
 - Disconnect any operating lines providing air pressure, electric power, or a control signal to the actuator. Be sure the actuator cannot suddenly open or close the valve.
 - Use bypass valves or completely shut off the process to isolate the valve from process pressure. Relieve process pressure from both sides of the valve. Drain the process media from both sides of the valve.
 - Safely vent the power actuator loading pressure.
 - Check with your process or safety engineer for any hazards that may be present from exposure to process media.
-

Installing the Size 1 Locking Mechanism

To add the locking mechanism (figure 5) to an existing actuator, purchase the required kit from Emerson Process Management.

1. Ensure the diaphragm rod assembly (key 10) is in the upward position and the lever (key 14) is against the up travel stop (spring fail position).
2. Thread the supplied jam nut (key 40) all the way onto the threaded bolt portion of the mounting plate assembly.
3. Loosen the down travel stop hex nut (key 24) and remove the travel stop cap screw (key 23).
4. Remove the vent screen (key 47) from the threaded hole in the bottom of the actuator housing.
5. Secure the locking plate (key 39) to the bottom of the housing assembly by reinstalling the down travel stop (key 23) and hex nut (key 24). Ensure the clearance hole in the locking plate is aligned with the threaded hole in the bottom of the housing.
6. Ensure the down travel stop is adjusted correctly to achieve the desired actuator rotational output.
7. Install the mounting plate assembly (key 38) by inserting it through the clearance hole in the locking plate and threading it into the hole in the actuator housing.

Figure 5. Size 1 Locking Mechanism

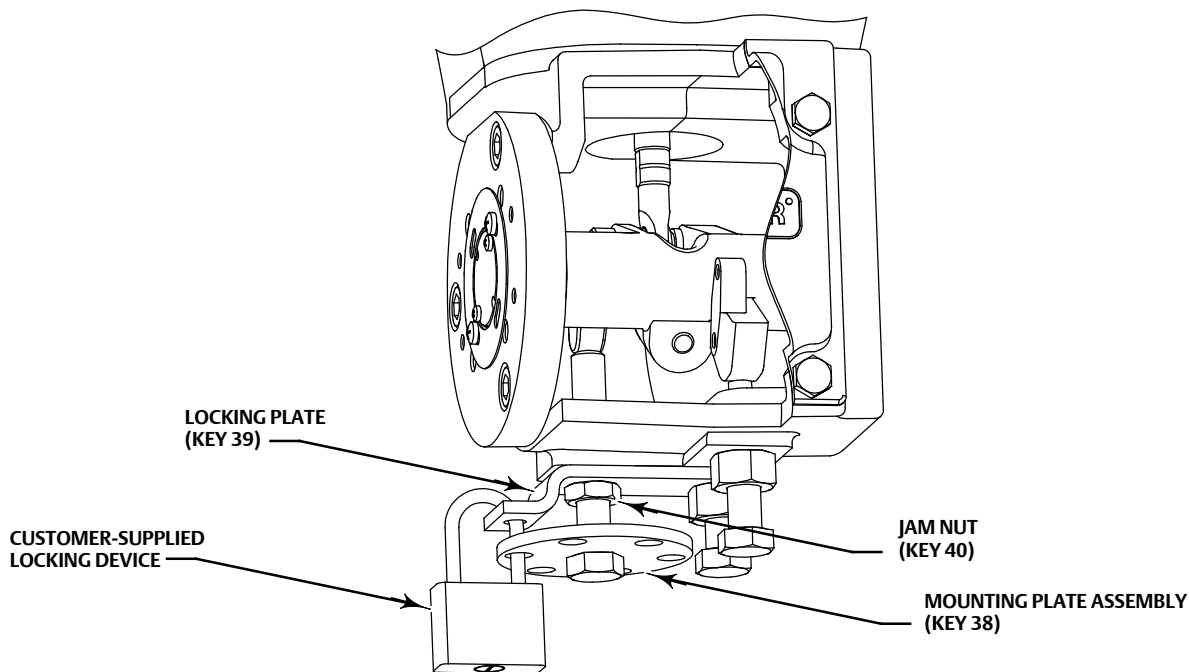

GE51941_A

Operating the Locking Mechanism (Size 1)

To Lock the Actuator

1. Screw the mounting plate assembly into the housing until it contacts the actuator lever.
2. Align the hole in the locking plate (key 39) with one of the holes in the disk of the mounting plate assembly.
3. Tighten the jam nut (key 40) against the locking plate.
4. Insert a padlock (not furnished by Emerson Process Management) to prevent the mounting plate assembly from rotating.

To Unlock the Actuator

1. Remove the padlock. Loosen the jam nut (key 40), and unscrew the threaded bolt until it no longer protrudes inside the housing.

Note

Ensure the mounting plate assembly bolt is unthreaded far enough that the actuator lever will not contact the bolt during normal actuator operation.

2. If the mounting plate assembly is to be left partially threaded into the housing, lock it with the jam nut (key 40) so that it cannot be screwed further into the housing and interfere with normal actuator operation.

Figure 6. Size 2 and 3 Locking Mechanism

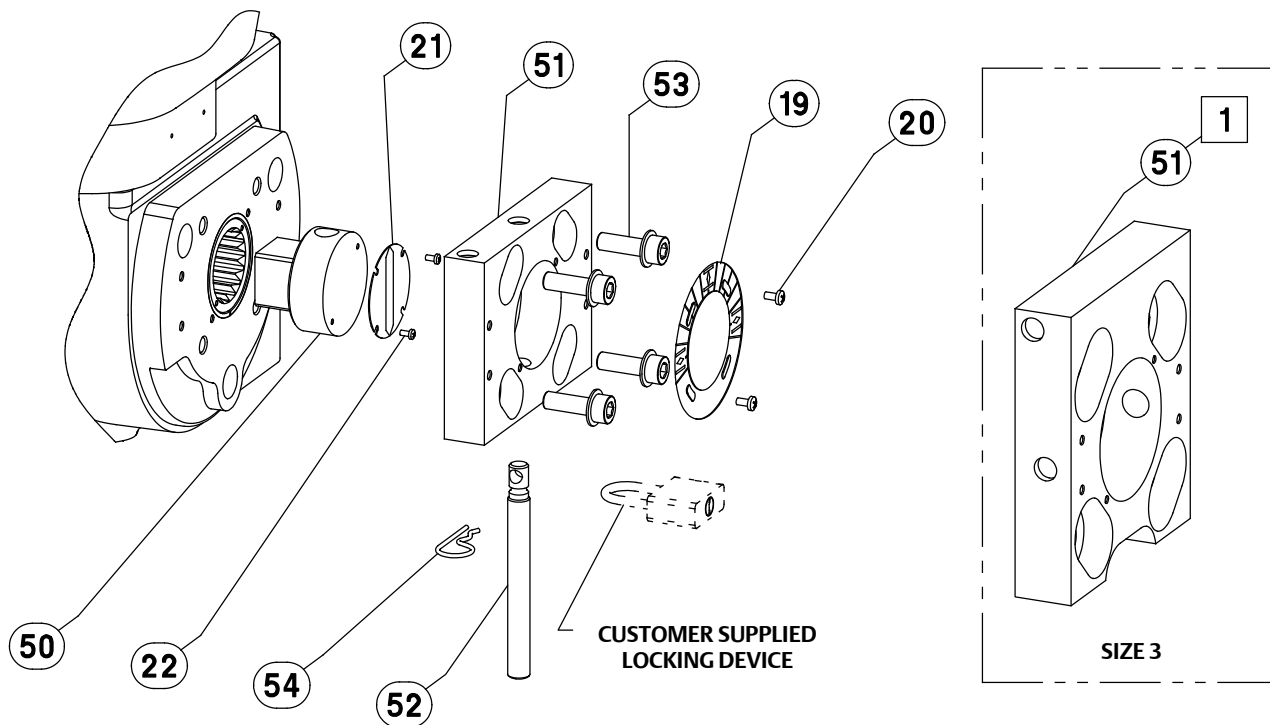

1 PART ORIENTATION FOR SIZE 3 END-MOUNT INSTRUMENT

Installing the Size 2 and 3 Locking Mechanism

To add the locking mechanism (figure 6) to an existing actuator, purchase the required kit from Emerson Process Management.

1. The actuator should be mounted to the valve body and both travel stops (key 23) properly positioned prior to installing the locking mechanism.

2. Ensure the actuator lever (key 14) is in the spring-fail position (against the up travel stop).
3. Assemble the lockout kit by positioning the locking shaft (key 50) within the center through-hole of the mounting plate (key 51), as shown in figure 6. Insert the locking pin (key 52) through the center pinhole of the mounting plate and through the pin hole in the locking shaft. Install the hairpin cotter pin (key 54) for retention.
4. If installing the lockout kit on an existing actuator, remove the travel indicator (key 21) and travel indicator scale (key 19) from the actuator by loosening the appropriate screws.
5. Position the lockout kit against the actuator outboard end. The locking shaft will insert and engage the lever end geometry.

Size 2 actuator: The standard size 2 lockout kit orientation shown in figure 6 will accommodate the use of window-mount and end-mount digital valve controllers, positioners, and accessories. This orientation requires removal of the locking pin in the direction of the bottom side of the actuator.

Size 3 actuator: For the window mounted DVC6200 digital valve controller, the size 3 lockout kit should be oriented such that locking pin removal is in the direction of the bottom side of the actuator. This mounting plate position provides necessary clearance with the integral supply pressure regulator. For the end-mount digital valve controller or accessory option, the size 3 lockout kit should be oriented as shown in the inset picture of figure 6.

6. Loosely install the four flanged cap screws (key 53). Prior to tightening the fasteners, ensure the through-hole in the mounting plate is centered around the outside diameter of the locking shaft (key 50). Rotate the assembly by hand in the appropriate direction opposite of anticipated lever rotation to eliminate initial clearance among parts.
7. Tighten the cap screws (key 53) per the recommended torque values in table 6.
8. Install the travel indicator (key 21) and travel indicator scale (key 19) to the lockout parts as illustrated in figure 6.

⚠ WARNING

To avoid personal injury or property damage, ensure the travel indicator is installed correctly to coincide with the desired actuator action. Refer to figure 3 for more information.

9. For normal actuator operation, remove the hairpin cotter pin (key 54) and locking pin (key 52) from the center pinhole of the mounting plate and reinstall these parts in the second pinhole for storage.

Operating the Locking Mechanism (Size 2 & 3)

To Lock the Actuator

1. With the actuator lever (key 14) against the up travel stop (spring-fail position), insert the locking pin (key 52) through the center pinhole of the mounting plate and through the pin hole in the locking shaft. Install the hairpin cotter pin (key 54) for retention.
2. Install the customer-supplied locking device to further prevent removal of the locking pin.

To Unlock the Actuator

1. Remove the customer-supplied locking device.
2. Remove the hairpin cotter pin (key 54) and locking pin (key 52) from the center pinhole of the mounting plate and reinstall these parts in the second pinhole for storage.

⚠ WARNING

To avoid personal injury or property damage, be aware the travel indicator scale (key 19) retains the locking shaft (key 50) during normal actuator operation. Removal of the travel indicator scale could allow the locking shaft to fall out in certain actuator orientations.

Parts Ordering

When corresponding with your Emerson Process Management sales office about this equipment, refer to the serial number found on the actuator nameplate.

⚠ WARNING

Use only genuine Fisher replacement parts. Components that are not supplied by Emerson Process Management should not, under any circumstances, be used in any Fisher valve, because they may void your warranty, might adversely affect the performance of the valve, and could cause personal injury and property damage.

Parts List

Note

Part numbers are shown for recommended spares only. For part numbers not shown, contact your Emerson Process Management sales office.

Key	Description	Part Number	Key	Description	Part Number
1	Housing Assembly		14	Lever	
1a*	Bushing		15	Cap Screw	
	Size 1	GE27672X012	16	Cap Screw	
	Size 2	GE32316X012	17	Hex Nut	
	Size 3	GE34956X012	18	Insert	
2	Cover or Plug		19	Travel Indicator Scale	
3	End Plate Assembly		20	Self Tapping Screw	
3a*	Bushing		21	Travel Indicator	
	Size 1	GE27672X012	22	Machine Screw	
	Size 2	GE32316X012	23	Cap Screw	
	Size 3	GE34956X012	24	Hex Nut	
4	Cap Screw		25	Cover Plate	
5	Top Casing Assembly		26	Cap Screw	
6	Diaphragm Plate		27	Mounting Yoke	
7	Cap Screw		28	Cap Screw	
8	Cap Screw		29	Label	
9	Hex Nut		30	Nameplate	
10	Diaphragm Rod Assembly		31	Drive Screw	
11*	Diaphragm		32	Handwheel	
	Size 1	GE28042X012	33	Slotted Hex Nut	
	Size 2	GE31917X012	34	Cotter Pin	
	Size 3	GE34829X012	35	Screw	
12	Spring, Inner		36	Pusher Assembly	
13	Spring, Outer		37	Groove Pin	
			41	Warning Label	
			42	Washer	
			43	Hex Nut	
			44*	O-Ring	
				Size 1	1D237506992
				Size 2	1D237506992
			45	Lubricant	
			46	Lubricant	
			47	Vent Screen	
			48*	Guide Assembly	
			49	Lockout Kit	
				Size 1	GE51941X012
				Size 2	GE52968X012
				Size 3	GE52968X022

* Recommended spare parts

Figure 7. Fisher 2052 Actuator Assembly

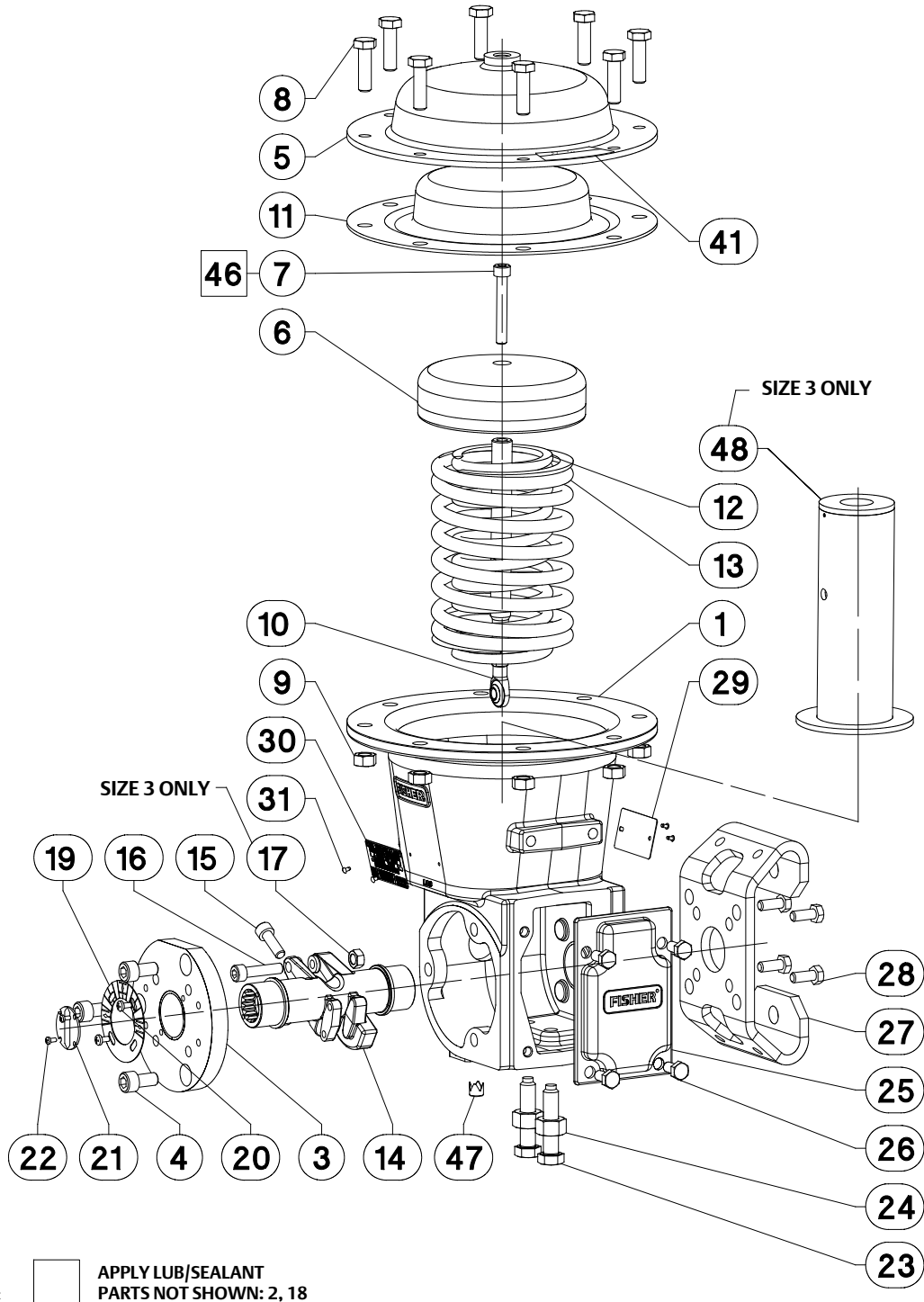
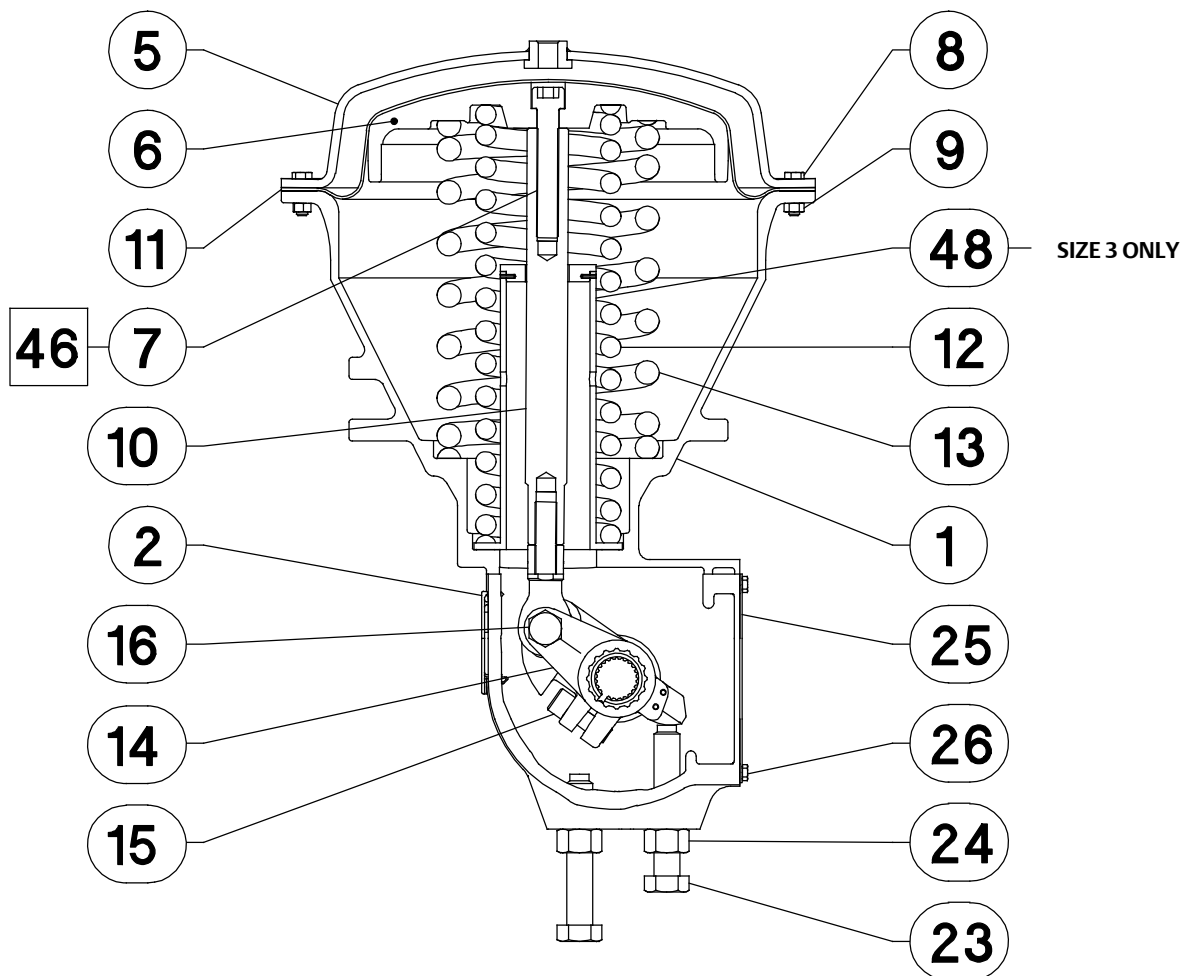

Figure 8. Fisher 2052 Size 3 Actuator Assembly



APPLY LUB/SEALANT

GE52013-A

Figure 9. Fisher 2052 Size 1 Handwheel Assembly

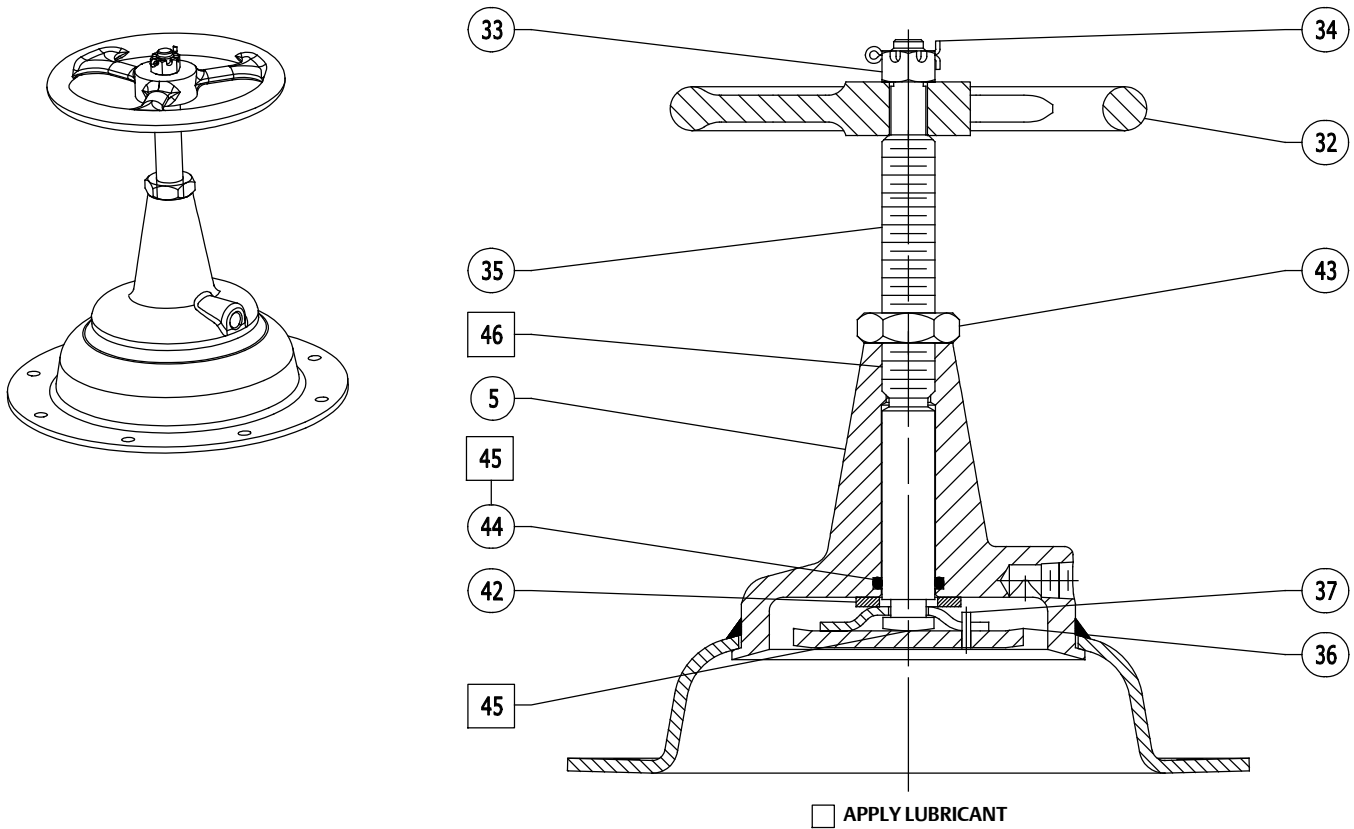

GE33241_A

Neither Emerson, Emerson Process Management, nor any of their affiliated entities assumes responsibility for the selection, use or maintenance of any product. Responsibility for proper selection, use, and maintenance of any product remains solely with the purchaser and end user.

Fisher, Control-Disk, and GO are marks owned by one of the companies in the Emerson Process Management business division of Emerson Electric Co. Emerson Process Management, Emerson, and the Emerson logo are trademarks and service marks of Emerson Electric Co. All other marks are the property of their respective owners.

The contents of this publication are presented for informational purposes only, and while every effort has been made to ensure their accuracy, they are not to be construed as warranties or guarantees, express or implied, regarding the products or services described herein or their use or applicability. All sales are governed by our terms and conditions, which are available upon request. We reserve the right to modify or improve the designs or specifications of such products at any time without notice.

Emerson Process Management

Marshalltown, Iowa 50158 USA
 Sorocaba, 18087 Brazil
 Chatham, Kent ME4 4QZ UK
 Dubai, United Arab Emirates
 Singapore 128461 Singapore

www.Fisher.com

