

# H200 Series Relief Valves



W1929-1

Figure 1. External View of H200 Series Relief Valve



W0120-1

Figure 2. Sectional View of H200 Series Relief Valve

## Introduction

The H200 Series Pop™ relief valves, Figures 1 and 2, are self-operated relief valves with preset and pinned spring retainers. The inlet pressure registers directly on a spring-opposed poppet assembly which includes a Nitrile (NBR) disk. When the inlet gas pressure increases above the spring setting, the poppet and disk assembly is pushed away from the orifice. Springs are available that provide any relief pressure setting from 25 to 300 psig (1,7 to 20,7 bar).

With this simple operation and wide spring setting selection, the H200 Series Pop relief valves may be used where venting to atmosphere is acceptable, where the process gas is compatible with the Nitrile (NBR) disk, where its relief capacity is adequate, and where some pressure relieving tolerance is acceptable. Common applications include use on pneumatic control lines of air drills, jackhammers and other similar equipment, and on farm tap installations. The H200 Series is comprised of the Types H202 and H203 relief valves with the difference being in the inlet connection size.

## Features

- **Space-Saving Construction** - Small relief valve size allows installation where space is limited.
- **Economical** - Low initial cost, easy installation, and high capacity per dollar invested reduces total cost of having relief valve capabilities in your system.
- **Durable** - Brass body construction and stainless steel spring reduces susceptibility to corrosion damage and the preset, pinned spring retainer prevents relief valve setpoint tampering.

## Installation

This relief valve may be installed in any position but must be oriented so that gas discharged from the valve does not create a fire, toxic, or explosion hazard. The relief valve should be protected from material and conditions that could clog the outlet side of the valve and affect the venting of gas.

A typical installation is shown in Figure 3. A Type P145 raincap is recommended for use with any H200 Series relief valve. Dimensions are shown in Figure 4.

The relief valve and installation should be checked for compliance with all applicable codes.



# Bulletin 71.4:H200

## Specifications

### Available Configurations and End Connections

**Type H202:** 3/4 NPT connection

**Type H203:** 1 NPT connection

### Maximum Allowable Relief (Inlet) Pressure<sup>(1)</sup>

400 psig (27,6 bar)

### Relief Pressure Ranges<sup>(1)</sup>

See Tables 1 and 2

### Flow Capacity

See Table 2

### Representative Wide-Open Sizing Coefficient

**C<sub>g</sub>:** 405

### Construction Materials

**Body, Poppet, and Spring Retainer:** Brass

**Disk:** Nitrile (NBR)

**Spring:** 302 Stainless Steel

### Temperature Capabilities<sup>(1)</sup>

-20° to 160°F (-29° to 71°C)

### Approximate Weight

0.5 pounds (0,2 kg)

### Option

Type P145 raincap

1. The pressure/temperature limits in this Bulletin or any applicable code limitations should not be exceeded.

**Table 1. Relief Pressure Spring Ranges**

RELIEF PRESSURE SETTINGS		SPRING PART NUMBER	SPRING COLOR	RELIEF SETTING TOLERANCE	
Psig	bar			Psig	bar
25 to 30	1,7 to 2,1	1H485637022	Pink	±5	±0,34
31 to 55	2,1 to 3,8	1J152137022	White		
56 to 75	3,9 to 5,2	1P391137022	Blue	±8	±0,55
65 to 95	4,5 to 6,5	T1049037022	Plain		
90 to 130	6,2 to 9,0	1F791337022	Purple		
131 to 160	9,0 to 11,0	1F7912T0012	Yellow	±15	±1,03
161 to 190	11,1 to 13,1	T12699T0012	Green		
191 to 235	13,2 to 16,2	1F790937022	Brown		
236 to 300	16,3 to 20,7	1E954637052	Plain		

**Table 2. Relief Set Pressures and Capacities**

RELIEF SET PRESSURE <sup>(2)</sup>		SET PRESSURE PLUS BUILD-UP		FLOW CAPACITY, SCFH (Nm <sup>3</sup> /h) <sup>(1)</sup>
Psig	bar	Psig	bar	
25	1,7	50	3,4	34 200 (916)
50	3,4	75	5,2	47 400 (1270)
75	5,2	100	6,9	60 000 (1608)
100	6,9	120	8,3	69 600 (1865)
125	8,6	150	10,3	83 400 (2235)
150	10,3	180	12,4	100 500 (2693)
175	12,1	210	14,5	117 600 (3152)
200	13,8	240	16,5	132 000 (3538)
225	15,5	270	18,6	150 000 (4020)
250	17,2	300	20,7	165 000 (4422)
275	19,0	330	22,7	180 000 (4824)
300	20,7	360	24,8	195 000 (5226)

1. This is the initial leak point, the point at which the relief valve begins to discharge.

2. 0.6 Specific Gravity Gas. To convert to equivalent capacities of other gases, multiply the table values by 0.775 for air or 0.789 for nitrogen. Multiply the flow obtained by 0.0268 to convert to (Nm<sup>3</sup>/h) at 0°C and 1,01 bar.

## Ordering Information

When ordering an H200 Series relief valve, specify the type number and the relief pressure setting required.

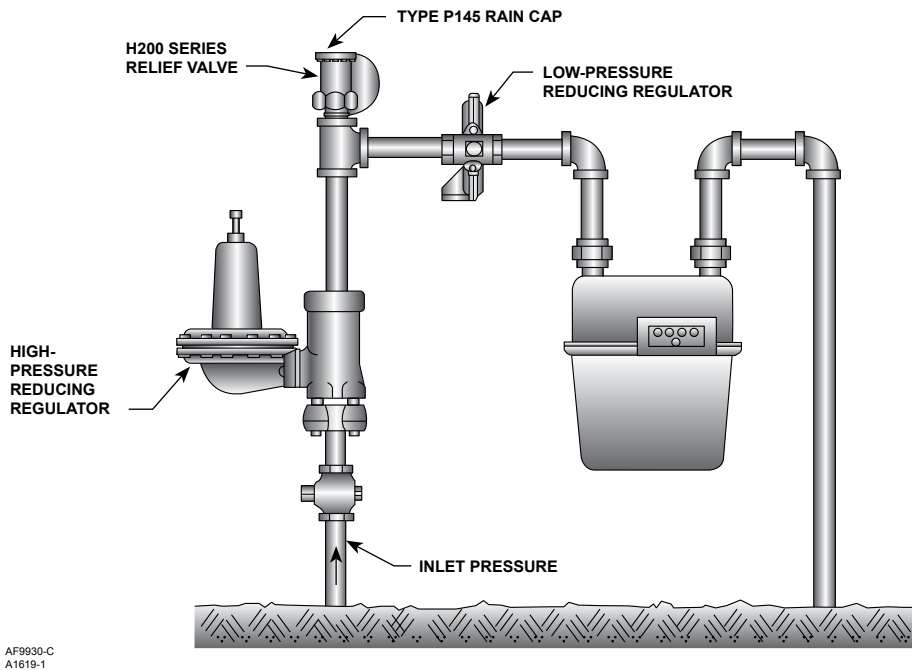

Figure 3. Typical Farm Tap Installation

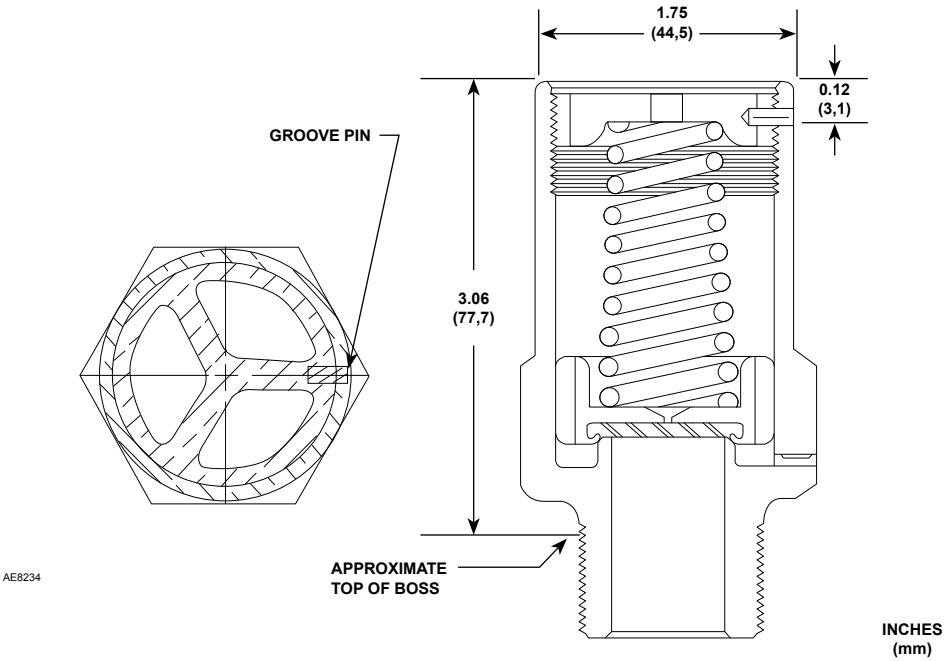

Figure 4. Dimensions

## Industrial Regulators

### Emerson Process Management Regulator Technologies, Inc.

USA - Headquarters  
McKinney, Texas 75069-1872 USA  
Tel: 1-800-558-5853  
Outside U.S. 1-972-548-3574

Asia-Pacific  
Shanghai, China 201206  
Tel: +86 21 2892 9000

Europe  
Bologna, Italy 40013  
Tel: +39 051 4190611

Middle East and Africa  
Dubai, United Arab Emirates  
Tel: +971 4811 8100

## Natural Gas Technologies

### Emerson Process Management Regulator Technologies, Inc.

USA - Headquarters  
McKinney, Texas 75069-1872 USA  
Tel: 1-800-558-5853  
Outside U.S. 1-972-548-3574

Asia-Pacific  
Singapore, Singapore 128461  
Tel: +65 6777 8211

Europe  
Bologna, Italy 40013  
Tel: +39 051 4190611  
Gallardon, France 28320  
Tel: +33 (0)2 37 33 47 00

## TESCOM

### Emerson Process Management Tescom Corporation

USA - Headquarters  
Elk River, Minnesota 55330-2445 USA  
Tel: 1-763-241-3238

Europe  
Selmsdorf, Germany 23923  
Tel: +49 (0) 38823 31 0

For further information visit [www.fisherregulators.com](http://www.fisherregulators.com)

The Emerson logo is a trademark and service mark of Emerson Electric Co. All other marks are the property of their prospective owners. Fisher is a mark owned by Fisher Controls, Inc., a business of Emerson Process Management.

*The contents of this publication are presented for informational purposes only, and while every effort has been made to ensure their accuracy, they are not to be construed as warranties or guarantees, express or implied, regarding the products or services described herein or their use or applicability. We reserve the right to modify or improve the designs or specifications of such products at any time without notice.*

Emerson Process Management does not assume responsibility for the selection, use or maintenance of any product. Responsibility for proper selection, use and maintenance of any Emerson Process Management product remains solely with the purchaser.