

Installation Manual

P/N 20001700, Rev. C

November 2007

Micro Motion[®] Model 1700 and Model 2700 Transmitters

Installation Manual



Contents

Chapter 1	Before You Begin	1
1.1	Overview	1
1.2	Safety	1
1.3	Flowmeter components	2
1.4	Transmitter type, installation type, and outputs option board	2
1.5	Transmitter installation procedures	3
1.6	Flowmeter documentation	3
1.7	Micro Motion customer service	4
Chapter 2	Installing the Transmitter	5
2.1	Overview	5
2.2	Installation architecture	5
2.3	Determining an appropriate location	7
2.3.1	Environmental requirements	7
2.3.2	Hazardous area classifications	7
2.3.3	Power source	7
2.3.4	Maximum cable lengths	9
2.3.5	Accessibility for maintenance	9
2.4	Mounting the transmitter	9
2.4.1	Integral installations	10
2.4.2	4-wire remote or remote core processor with remote transmitter installations	11
2.4.3	9-wire remote installations	12
2.5	Mounting the remote core processor	13
2.6	Grounding the flowmeter components	15
2.7	Supplying power	16
2.8	Rotating the display	16
Chapter 3	Wiring the Transmitter to the Sensor	19
3.1	Overview	19
3.2	Cable types	19
3.2.1	4-wire cable	20
3.2.2	9-wire cable	20
3.3	Wiring for 4-wire remote installations	20
3.4	Wiring for 9-wire remote installations	22
3.5	Wiring for remote core processor with remote transmitter installations	23
Chapter 4	Output Wiring – Model 1700/2700 Analog Transmitters	29
4.1	Overview	29
4.2	Output terminals and output types	29
4.3	Output wiring	29

Chapter 5	Output Wiring – Model 1700/2700 Intrinsically Safe Transmitters . . .	33
5.1	Overview	33
5.2	Output terminals and output types	33
5.3	Safe area output wiring	34
5.3.1	Safe area mA output wiring	34
5.3.2	Safe area frequency/discrete output wiring	36
5.4	Hazardous area output wiring	37
5.4.1	Hazardous area safety parameters	37
5.4.2	Hazardous area mA output wiring	39
5.4.3	Hazardous area frequency/discrete output wiring	39
Chapter 6	Output Wiring – Model 2700 Configurable I/O Transmitters	41
6.1	Overview	41
6.2	Channel configuration	41
6.3	mA output wiring	42
6.4	Frequency output wiring	44
6.5	Discrete output wiring	47
6.6	Discrete input wiring	50
Chapter 7	Output Wiring – Model 2700 FOUNDATION fieldbus and PROFIBUS-PA Transmitters	53
7.1	Overview	53
7.2	FOUNDATION fieldbus wiring	53
7.3	PROFIBUS-PA wiring	54
Appendix A	Specifications	55
A.1	Functional specifications	55
A.1.1	Electrical connections	55
A.1.2	Input/output signals	56
A.1.3	Digital communication	61
A.1.4	Power supply	62
A.1.5	Environmental requirements	62
A.1.6	Ambient temperature effect	62
A.1.7	EMC compliance	62
A.2	Hazardous area classifications	63
A.2.1	UL and CSA	63
A.2.2	ATEX and IECEx	63
A.3	Performance specifications	64
A.4	Physical specifications	64
A.4.1	Housing	64
A.4.2	Mounting	64
A.4.3	Interface/display	65
A.4.4	Weight	65
A.4.5	Dimensions	65
Index		71

Chapter 1

Before You Begin

1.1 Overview

This chapter provides an orientation to the use of this manual. This manual describes the procedures required to install the following Model 1700 and 2700 transmitters:

- Model 1700 or Model 2700 with analog outputs option board
- Model 1700 or Model 2700 with intrinsically safe analog outputs option board
- Model 2700 with configurable input/outputs option board
- Model 2700 with FOUNDATION fieldbus™ option board
- Model 2700 with PROFIBUS-PA option board

If you do not know what transmitter you have, see Section 1.4 for instructions on identifying the transmitter type from the model number on the transmitter's tag.

Note: Installation information for Model 1500 transmitters or Model 2500 transmitters is provided in a separate manual. See the manual for your transmitter.

1.2 Safety

Safety messages are provided throughout this manual to protect personnel and equipment. Read each safety message carefully before proceeding to the next step.

WARNING

Improper installation in a hazardous area can cause an explosion.

For information about hazardous applications, refer to the approval documentation, shipped with the transmitter or available from the Micro Motion web site.

WARNING

Hazardous voltage can cause severe injury or death.

Make sure power is disconnected before installing transmitter.

CAUTION

Improper installation could cause measurement error or flowmeter failure.

Follow all instructions to ensure transmitter will operate correctly.

Before You Begin

1.3 Flowmeter components

The Model 1700 or 2700 transmitter is one component in your Micro Motion flowmeter. Other major components include:

- The sensor, which provides measurement functions
- The core processor, which provides memory and processing functions

1.4 Transmitter type, installation type, and outputs option board

To install the transmitter, you must know your transmitter type, installation type, and outputs option board. This section provides information on obtaining this information. The codes described below match the codes that were used to order your transmitter.

1. Obtain the transmitter's model number, which is provided on a tag attached to the side of the transmitter.
 - Model 1700 transmitters have a model number of the form **1700xxxxxxxxxx**.
 - Model 2700 transmitters have a model number of the form **2700xxxxxxxxxx**.
2. The fifth character in the model number (**xxxxXxxxxxxxxx**) represents the installation type that was ordered:
 - R = remote (4-wire remote installation)
 - I = integral (transmitter mounted on sensor)
 - C = transmitter/core processor assembly (9-wire remote installation)
 - B = remote core processor with remote transmitter

Note: For more information on installation type, see Figure 2-1.

3. The eighth character in the model number (**xxxxxxxxXxxxxx**) represents the outputs option board.
 - A = transmitter with analog outputs option board (one mA, one frequency, one RS-485)
 - B = transmitter with configurable input/outputs option board, default output configuration (two mA, one frequency)
 - C = transmitter with configurable input/outputs option board, customized output configuration
 - D = transmitter with intrinsically safe analog outputs option board
 - E = transmitter with intrinsically safe (FISCO compliant) FOUNDATION fieldbus outputs option board
 - N = transmitter with non-incendive (FNICO compliant) FOUNDATION fieldbus outputs option board
 - G = transmitter with PROFIBUS-PA outputs option board

Note: The remaining characters in the model number describe options that do not affect transmitter installation.

The following examples illustrate use of the model number to determine transmitter type, installation type, and output board type:

- **1700RxxAxxxxxx** = Model 1700 remote transmitter with analog outputs option board
- **2700CxxDxxxxxx** = Model 2700 transmitter/core processor assembly with intrinsically safe outputs option board

1.5 Transmitter installation procedures

To install the transmitter, the following procedures are required:

- Install the transmitter – see Chapter 2
- Wire the transmitter to the sensor – see Chapter 3
- Wire the transmitter outputs:
 - For Model 1700 or 2700 analog outputs transmitters, see Chapter 4.
 - For Model 1700 or 2700 intrinsically safe analog outputs transmitters, see Chapter 5.
 - For Model 2700 configurable I/O transmitters, see Chapter 6.
 - For Model 2700 FOUNDATION fieldbus and PROFIBUS-PA outputs transmitters, see Chapter 7.

1.6 Flowmeter documentation

Table 1-1 lists documentation sources for other required information. Documents can be obtained in PDF form from the Micro Motion web site (www.micromotion.com/documentation).

Table 1-1 Flowmeter documentation resources

Topic	Document
Sensor installation	Installation manual shipped with sensor
Core processor installation (if mounted remotely from sensor and transmitter)	This document
Transmitter configuration, transmitter startup and use, and transmitter troubleshooting	<i>Series 1000 and 2000 Transmitter Configuration and Use Manual</i> or <i>Model 2700 Transmitter with FOUNDATION Fieldbus Installation and Operation Manual</i> or <i>Model 2700 Transmitter with PROFIBUS-PA Installation and Operation Manual</i>

Before You Begin

1.7 Micro Motion customer service

For technical assistance, phone the Micro Motion Customer Service department:

- In the U.S.A., phone **800-522-MASS** (800-522-6277) (toll free)
- In Canada and Latin America, phone +1 303-527-5200 (U.S.A.)
- In Asia:
 - In Japan, phone 3 5769-6803
 - In other locations, phone +65 6777-8211 (Singapore)
- In Europe:
 - In the U.K., phone 0870 240 1978 (toll-free)
 - In other locations, phone +31 (0) 318 495 555 (The Netherlands)

Customers outside the U.S.A. can also email Micro Motion customer service at *International.MMISupport@EmersonProcess.com*.

Chapter 2

Installing the Transmitter

2.1 Overview

This chapter describes how to install Micro Motion Model 1700 and 2700 transmitters. The following general steps are required:

- Determine the location of the transmitter and other flowmeter components (see Section 2.3)
- Mount the transmitter (see Section 2.4)
- Mount the core processor, if required (see Section 2.5)
- Ground the flowmeter components (see Section 2.6)
- Supply power to the flowmeter (see Section 2.7)
- Rotate the display, if desired and the transmitter has a display (see Section 2.8)

2.2 Installation architecture

Your flowmeter installation will match one of the architectures shown in Figure 2-1. Mounting, sensor wiring, and grounding requirements depend on this architecture. Your installation type should be consistent with the installation type specified in your transmitter model number (see Section 1.4).

Installing the Transmitter

Figure 2-1 Installation types

Integral

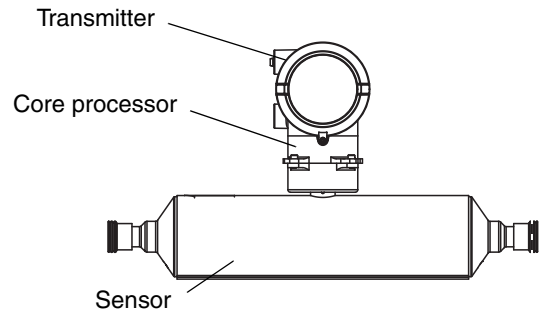

4-wire remote

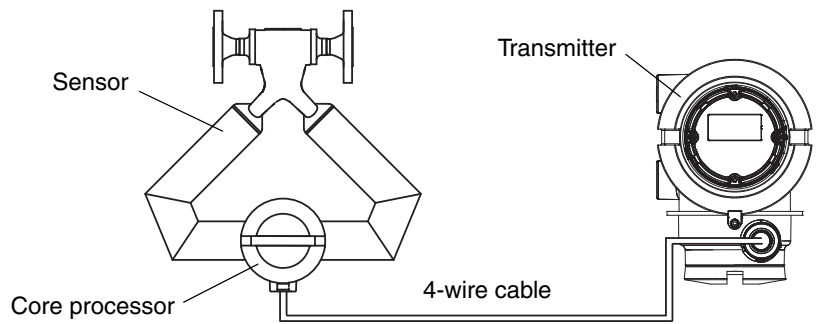

9-wire remote

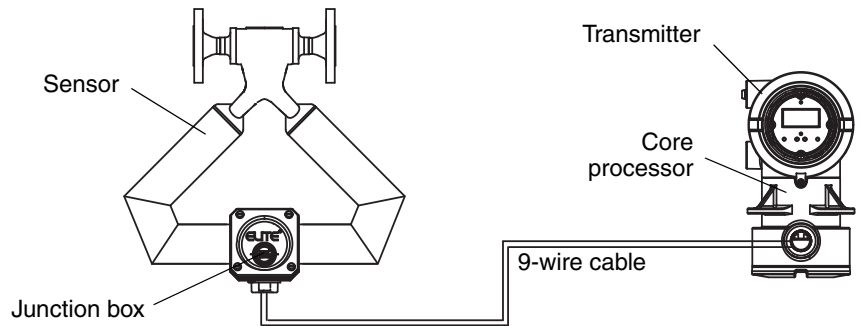

Remote core processor with remote transmitter

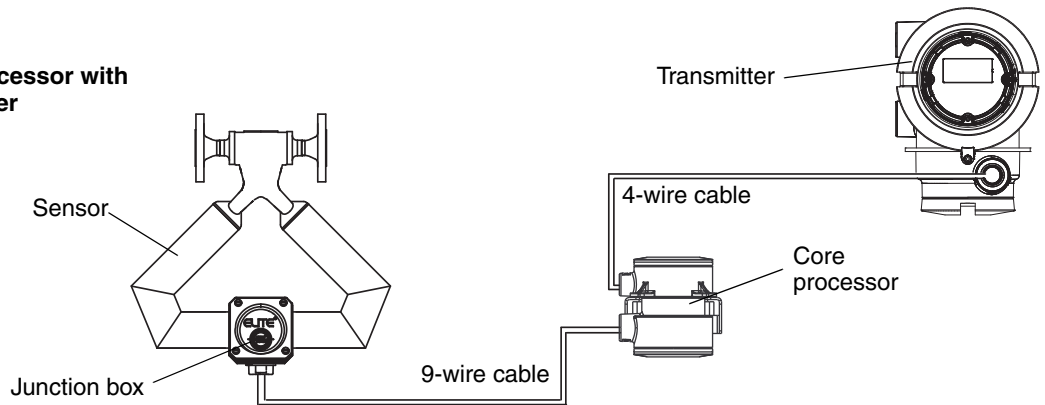

Installing the Transmitter

2.3 Determining an appropriate location

To determine an appropriate location for the transmitter, you must consider the environmental requirements of the transmitter and core processor, hazardous area classification, location of power source, cable lengths, accessibility for maintenance, and visibility of the display (if the transmitter is equipped with a display).

2.3.1 Environmental requirements

The transmitter's environmental requirements include temperature, humidity, and vibration.

Temperature limits

Install the transmitter in an environment where ambient temperature is between -40 and $+140$ °F (-40 and $+60$ °C). If possible, install the transmitter in a location that will prevent direct exposure to sunlight.

Different ambient temperature requirements may apply when installing the transmitter in a hazardous area. Refer to the approval documentation shipped with the transmitter or available on the Micro Motion web site.

Humidity limits

Install the transmitter in an environment where relative humidity is between 5 and 95%, non-condensing at 140 °F (60 °C).

Vibration limits

The transmitter meets IEC 68.2.6, endurance sweep, 5 to 2000 Hz, 50 sweep cycles at 1.0 g.

2.3.2 Hazardous area classifications

If you plan to mount the transmitter in a hazardous area:

- Verify that the transmitter has the appropriate hazardous area approval. Each transmitter has a hazardous area approval tag attached to the transmitter housing.
- Ensure that any cable used between the transmitter and the sensor meets the hazardous area requirements.

For more information about hazardous area classifications and requirements, see Section A.2.

2.3.3 Power source

Connect the transmitter to an AC or DC voltage source. The transmitter automatically recognizes the source voltage.

AC power requirements

If you are using AC power, the following requirements apply:

- 85–265 VAC
- 50/60 Hz
- 6 watts typical, 11 watts maximum

Installing the Transmitter

DC power requirements

Note: These requirements assume a single transmitter per cable. Connecting multiple transmitters to a single cable should be avoided.

If you are using DC power, the following requirements apply:

- 18–100 VDC
- 6 watts typical, 11 watts maximum
- At startup, the transmitter power source must provide a minimum of 1.5 amps of short-term current per transmitter.
- Length and conductor diameter of the power cable must be sized to provide 18 VDC minimum at the power terminals, at a load current of 0.5 amps. To size the cable, refer to Table 2-1 and use the following formula as a guideline:

$$\text{MinimumSupplyVoltage} = 18\text{V} + (\text{CableResistance} \times \text{CableLength} \times 0.5 \text{ A})$$

Table 2-1 Typical power cable resistances at 68 °F (20 °C)

Gauge	Resistance ⁽¹⁾
14 AWG	0.0050 Ω/foot
16 AWG	0.0080 Ω/foot
18 AWG	0.0128 Ω/foot
20 AWG	0.0204 Ω/foot
2,5 mm ²	0,0136 Ω/meter
1,5 mm ²	0,0228 Ω/meter
1 mm ²	0,0340 Ω/meter
0,75 mm ²	0,0460 Ω/meter
0,5 mm ²	0,0680 Ω/meter

(1) These values include the resistance of both high and low conductors in a cable.

Example

The transmitter is mounted 350 feet from a DC power supply. If you want to use 16 AWG cable, calculate the required voltage at the DC power supply as follows:

$$\text{MinimumSupplyVoltage} = 18\text{V} + (\text{CableResistance} \times \text{CableLength} \times 0.5\text{A})$$

$$\text{MinimumSupplyVoltage} = 18\text{V} + (0.0080 \text{ ohms/ft} \times 350 \text{ ft} \times 0.5\text{A})$$

$$\text{MinimumSupplyVoltage} = 19.4\text{V}$$

2.3.4 Maximum cable lengths

This requirement does not apply to integral installations (see Figure 2-1). For other installation types (see Figure 2-1), maximum cable length between flowmeter components depends on the installation type and the cable type. Refer to Figure 2-1, then see Table 2-2.

Table 2-2 Maximum cable lengths

Cable type	Wire gauge	Maximum length
Micro Motion 9-wire	Not applicable	60 feet (20 meters)
Micro Motion 4-wire	Not applicable	1000 feet (300 meters)
User-supplied 4-wire		
• Power wires (VDC)	22 AWG (0,35 mm ²)	300 feet (90 meters)
	20 AWG (0,5 mm ²)	500 feet (150 meters)
	18 AWG (0,8 mm ²)	1000 feet (300 meters)
• Signal wires (RS-485)	22 AWG (0,35 mm ²) or larger	1000 feet (300 meters)

2.3.5 Accessibility for maintenance

Ensure that the transmitter is mounted in a location and orientation that will allow easy access to the terminals and to the display (if your transmitter has a display).

2.4 Mounting the transmitter

You can mount the transmitter in any orientation as long as the conduit and wiring openings do *not* point upward. If possible, mount the transmitter so that there is at least 8–10" (200–250 mm) clearance at the rear of the housing to enable operator access to the wiring and power compartments. For transmitter dimensions, see Appendix A.

⚠ CAUTION

Condensation or excessive moisture entering the transmitter could damage the transmitter and result in measurement error or flowmeter failure.

To reduce the risk of measurement error or flowmeter failure:

- Ensure the integrity of gaskets and O-rings.
- Grease the O-rings every time the transmitter housing or core processor housing is opened and closed.
- Do not mount the transmitter with the conduit openings pointing upward.
- Install drip legs on conduit or cable.
- Seal the conduit openings.
- Fully tighten the transmitter cover.

Installing the Transmitter

2.4.1 Integral installations

If you chose an integral installation (see Figure 2-1), there are no special mounting instructions for the transmitter.

You can rotate an integrally mounted transmitter up to 360° in 90° increments, to one of four possible positions on the core processor base. See Figure 2-2.

Figure 2-2 Rotating the transmitter

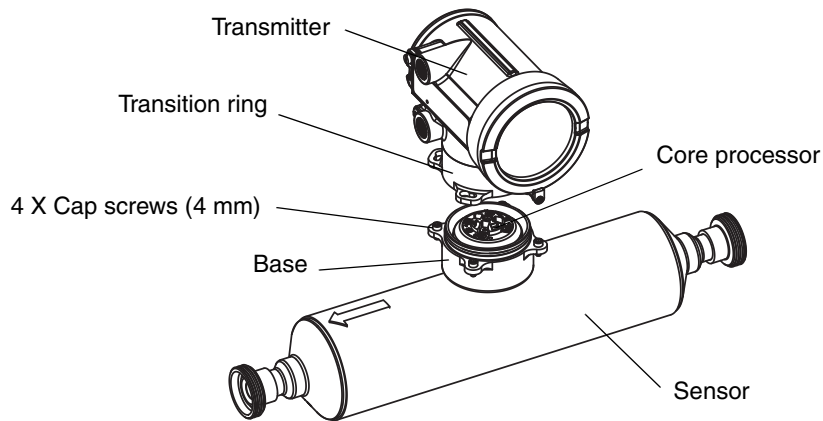

⚠ CAUTION

Damaging the wires that connect the transmitter to the core processor can cause measurement error or flowmeter failure.

To reduce the risk of damaging the wires, do not move the transmitter more than a few inches from the core processor. When reassembling the flowmeter, ensure that the wires will not be bent or pinched in the housing.

To rotate the transmitter on the core processor:

1. Loosen each of the four cap screws (4 mm) that fasten the transmitter to the base.
2. Rotate the transmitter counter-clockwise so that the cap screws are in the unlocked position.
3. Gently lift the transmitter straight up, disengaging it from the cap screws. Do not disconnect or damage the wires that connect the transmitter to the core processor.
4. Rotate the transmitter to the desired orientation, and align the slots with the cap screws. Do not pinch or stress the wires.
5. Gently lower the transmitter onto the base, inserting the cap screws into the slots.
6. Rotate the transmitter clockwise so that the cap screws are in the locked position.
7. Tighten the cap screws, torquing to 20 to 30 in-lbs (2,3 to 3,4 N-m).

⚠ CAUTION

Twisting the core processor will damage the sensor.

To reduce the risk of damaging the sensor, do not allow the core processor to rotate.

2.4.2 4-wire remote or remote core processor with remote transmitter installations

If you chose the 4-wire remote or the remote core processor with remote transmitter installation (see Figure 2-1), see Figure 2-3 for a diagram of the mounting bracket supplied with the transmitter. Both pipe mounting and wall mounting are shown. Ensure that the transmitter is mounted and oriented in a way that will allow easy access to the terminals and to the display (if your transmitter has a display).

Figure 2-3 4-wire remote – Wall mount or pipe mount

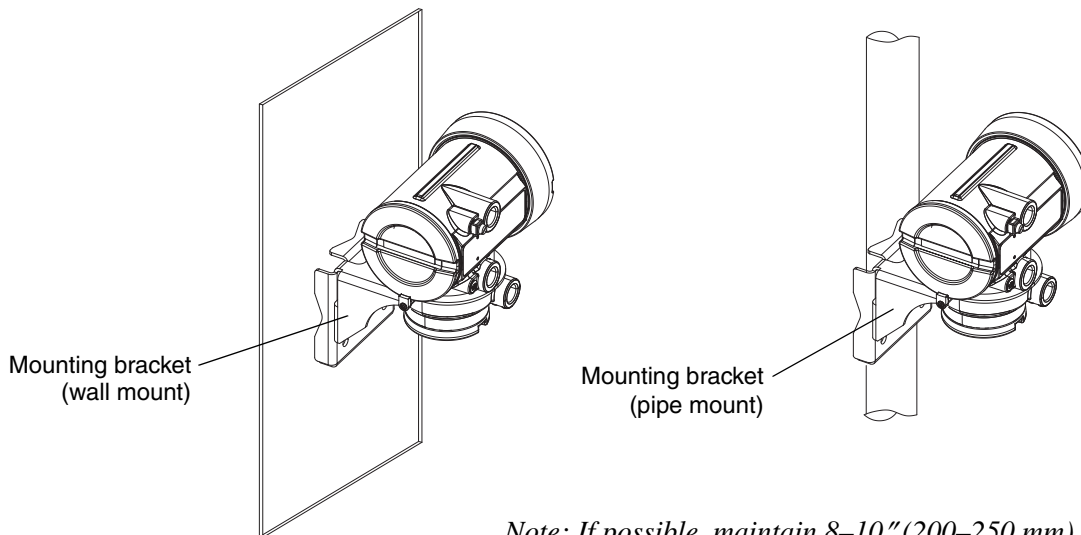

Note: If possible, maintain 8–10" (200–250 mm) clearance at the rear of the transmitter.

To mount the transmitter:

1. Identify the components shown in Figure 2-4. For dimensions, see Appendix A.
2. If desired, re-orient the transmitter on the bracket.
 - a. Remove the junction end-cap from the junction housing.
 - b. Loosen each of the four cap screws (4 mm) inside the junction housing.
 - c. Rotate the bracket so that the transmitter is oriented as desired.
 - d. Tighten the cap screws, torquing to 30 to 38 in-lbs (3 to 4 N-m).
 - e. Replace the junction end-cap.
3. Attach the mounting bracket to an instrument pole or wall. For pipe mount, two user-supplied U-bolts are required. Contact Micro Motion to obtain a pipe-mount installation kit if required.

Installing the Transmitter

Figure 2-4 Transmitter components – 4-wire remote or remote core processor with remote transmitter installations

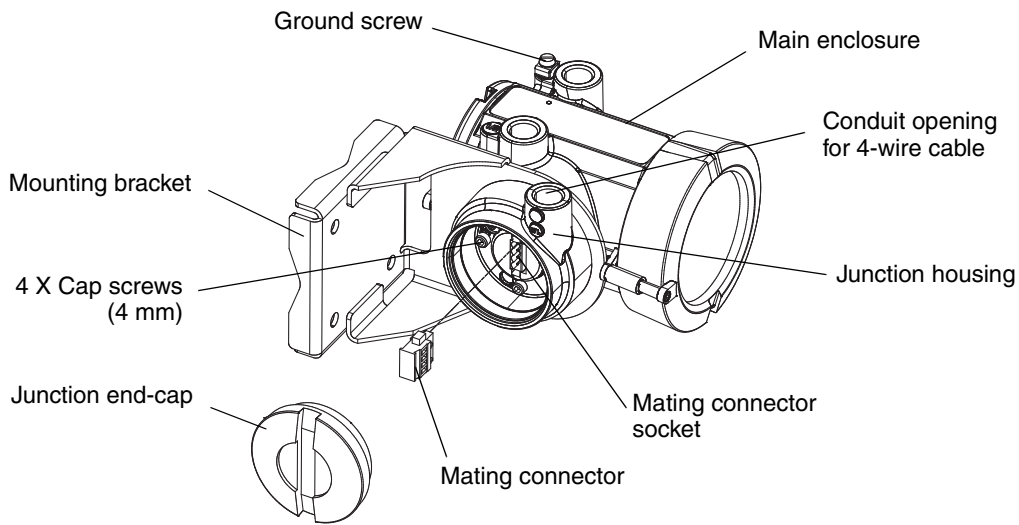

2.4.3 9-wire remote installations

If you chose a 9-wire remote installation (see Figure 2-1), see Figure 2-5 for a diagram of the mounting bracket supplied with the transmitter/core processor assembly. Ensure that the transmitter is mounted and oriented in a way that will allow easy access to the terminals and to the display (if your transmitter has a display).

Figure 2-5 9-wire remote – Wall mount or pipe mount

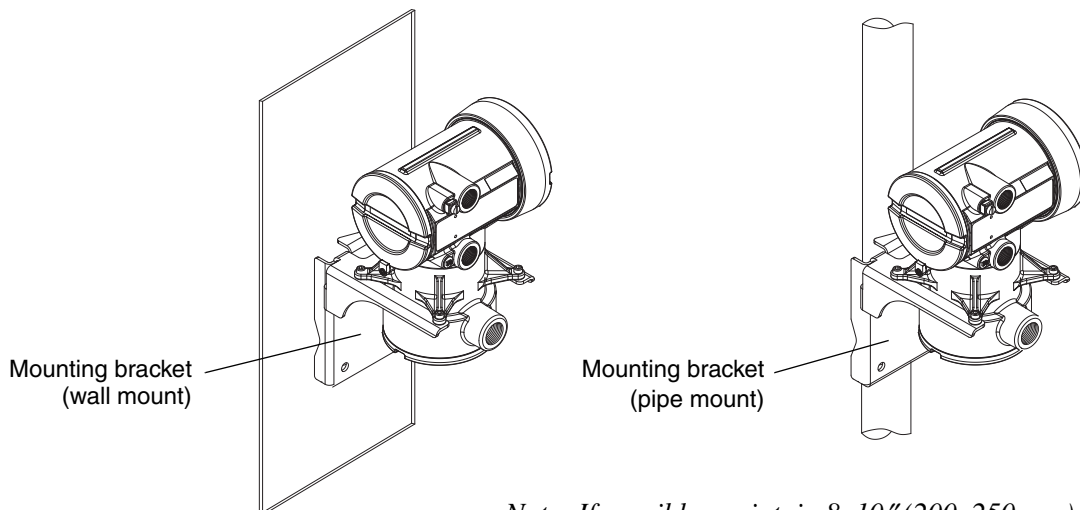

Note: If possible, maintain 8–10" (200–250 mm) clearance at the rear of the transmitter.

Installing the Transmitter

To mount the transmitter/core processor assembly:

1. Identify the components shown in Figure 2-6. For dimensions, see Appendix A.
2. If desired, re-orient the transmitter on the bracket.
 - a. Loosen each of the four cap screws (4 mm).
 - b. Rotate the bracket so that the transmitter is oriented as desired.
 - c. Tighten the cap screws, torquing to 30 to 38 in-lbs (3 to 4 N-m).
3. Attach the mounting bracket to an instrument pole or wall. For pipe mount, two user-supplied U-bolts are required. Contact Micro Motion to obtain a pipe-mount installation kit if required.

Figure 2-6 Transmitter/core processor assembly – Exploded view

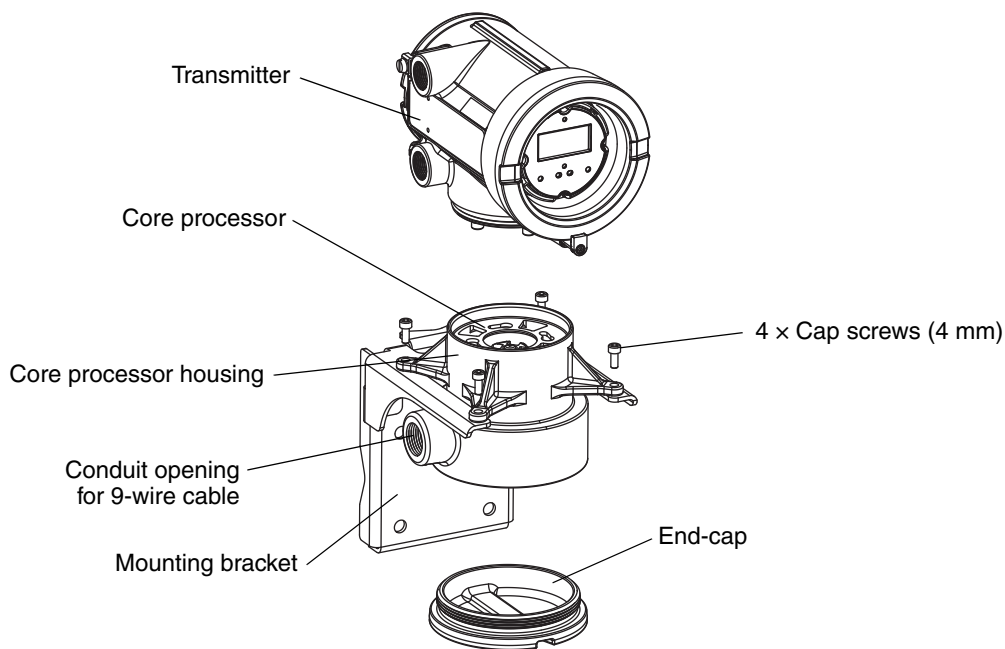

2.5 Mounting the remote core processor

Note: This step is required only for remote core processor with remote transmitter installations (see Figure 2-1). If you have an integral installation, 4-wire remote installation, or 9-wire remote installation, go to Section 2.6.

If you chose the remote core processor with remote transmitter installation (see Figure 2-1), see Figure 2-3 for a diagram of the mounting bracket supplied with the transmitter. Both pipe mounting and wall mounting are shown.

Installing the Transmitter

Figure 2-7 Remote core processor – Wall mount or pipe mount

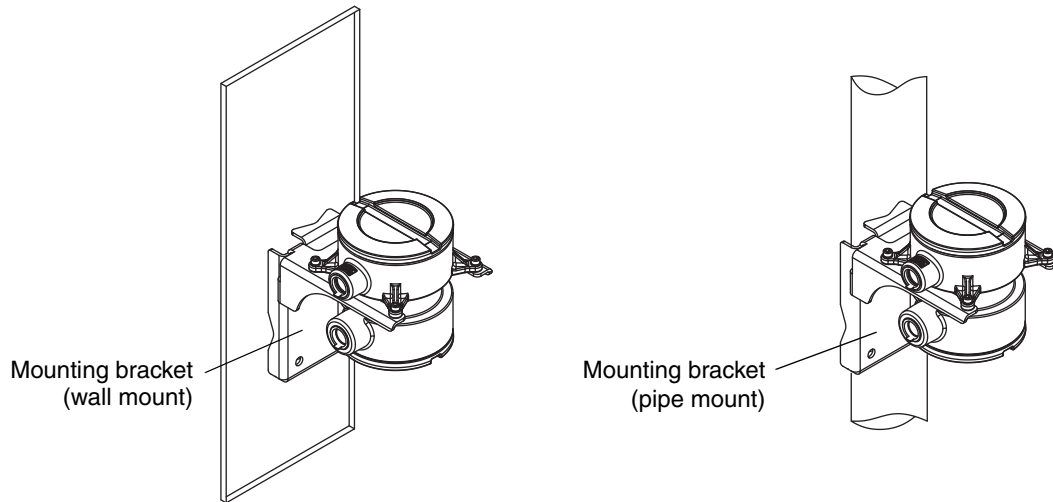

To mount the core processor:

1. Identify the components shown in Figure 2-8. For dimensions, see Appendix A.
2. If desired, reorient the core processor housing on the bracket.
 - a. Loosen each of the four cap screws (4 mm).
 - b. Rotate the bracket so that the core processor is oriented as desired.
 - c. Tighten the cap screws, torquing to 30 to 38 in-lbs (3 to 4 N-m).
3. Attach the mounting bracket to an instrument pole or wall. For pipe mount, two user-supplied U-bolts are required. Contact Micro Motion to obtain a pipe-mount installation kit if required.

Figure 2-8 Remote core processor components

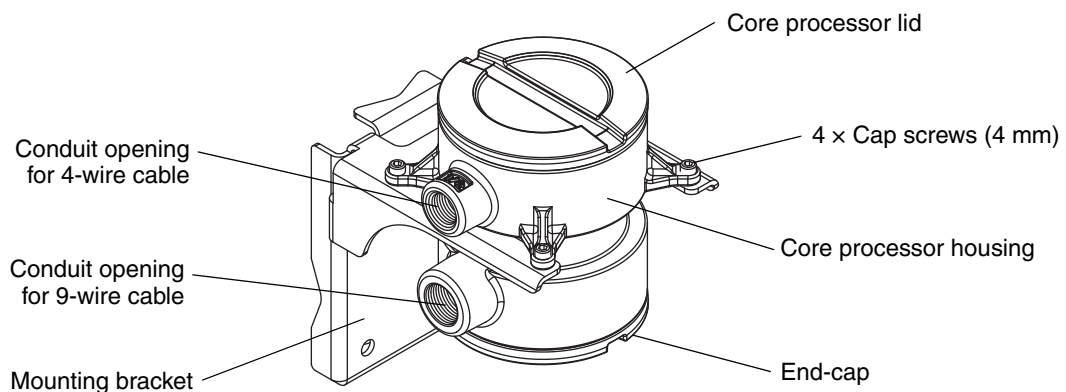

2.6 Grounding the flowmeter components

Grounding requirements depend on the installation type (see Figure 2-1). Grounding methods for each flowmeter component are listed in Table 2-3.

⚠ CAUTION

Improper grounding could cause measurement error.

To reduce the risk of measurement error:

- Ground the transmitter to earth, or follow ground network requirements for the facility.
- For installation in an area that requires intrinsic safety, refer to Micro Motion approval documentation, shipped with the transmitter or available from the Micro Motion web site.
- For hazardous area installations in Europe, refer to standard EN 60079-14 if national standards do not apply.

If national standards are not in effect, follow these grounding guidelines:

- Use copper wire, 14 AWG (2,5 mm²) or larger wire size, for grounding.
- Keep all ground leads as short as possible, less than 1 Ω impedance.
- Connect ground leads directly to earth, or follow plant standards.

Table 2-3 Grounding methods for flowmeter components

Installation architecture	Components	Grounding method
Integral	Sensor / core processor / transmitter	Ground via piping, if possible (see sensor documentation). Otherwise, ground according to applicable local standards using either the transmitter's internal or external ground screw.
4-wire remote	Sensor / core processor assembly	See sensor documentation.
	Transmitter	Ground according to applicable local standards, using either the transmitter's internal or external ground screw.
9-wire remote	Sensor / junction box	See sensor documentation.
	Transmitter / core processor assembly	Ground according to applicable local standards, using either the transmitter's internal or external ground screw, or the core processor's internal ground screw.
Remote core processor with remote transmitter	Sensor	See sensor documentation.
	Core processor	Ground according to applicable local standards, using either the internal or external ground screw.
	Transmitter	Ground according to applicable local standards, using either the transmitter's internal or external ground screw.

Installing the Transmitter

2.7 Supplying power

In all installations, power must be provided to the transmitter. Refer to Section 2.3.3 for information on the transmitter's power supply requirements.

A user-supplied switch may be installed in the power supply line. For compliance with low-voltage directive 2006/95/EC (European installations), a switch in close proximity to the transmitter is required.

Connect the power supply to terminals 9 and 10, under the Warning flap. Terminate the positive (line) wire on terminal 10 and the return (neutral) wire on terminal 9. Ground the power supply using the equipment ground, also under the Warning flap. See Figure 2-9.

Figure 2-9 Wiring the transmitter power supply

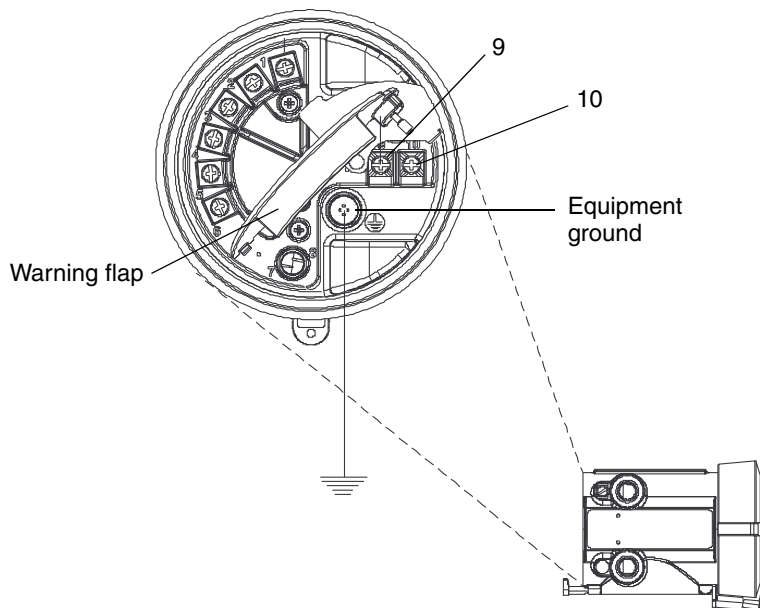

2.8 Rotating the display

If your transmitter has a display, you can rotate the display on the transmitter up to 360° in 90° increments.

⚠ WARNING

Removing the display cover in explosive atmospheres while the power is on can cause an explosion.

To reduce the risk of an explosion, before removing the display cover in explosive atmospheres, be sure to shut off the power and wait five minutes.

WARNING

Using a dry cloth to clean the display cover can cause static discharge, which could result in an explosion in an explosive atmosphere.

To reduce the risk of an explosion, always use a damp cloth to clean the display cover in an explosive atmosphere.

To rotate the display, follow the instructions below:

1. Power down the transmitter.
2. Remove the end-cap clamp by removing the cap screw. See Figure 2-10.
3. Turn the display cover counterclockwise to remove it from the main enclosure.
4. Carefully loosen (and remove if necessary) the semicaptive display screws while holding the display module in place.
5. Carefully pull the display module out of the main enclosure until the sub-bezel pin terminals are disengaged from the display module.

Note: The display pins may come out of the board stack with the display module. If this happens, simply remove the pins and reinstall them.

6. Rotate the display module to the desired position.
7. Insert the sub-bezel pin terminals into the display module pin holes to secure the display in its new position.
8. If you have removed the display screws, line them up with the matching holes on the sub-bezel, then reinsert and tighten them.
9. Place the display cover onto the main enclosure. Turn the display cover clockwise until it is snug.
10. Replace the end-cap clamp by reinserting and tightening the cap screw.
11. Restore power to the transmitter.

Installing the Transmitter

Figure 2-10 Display components

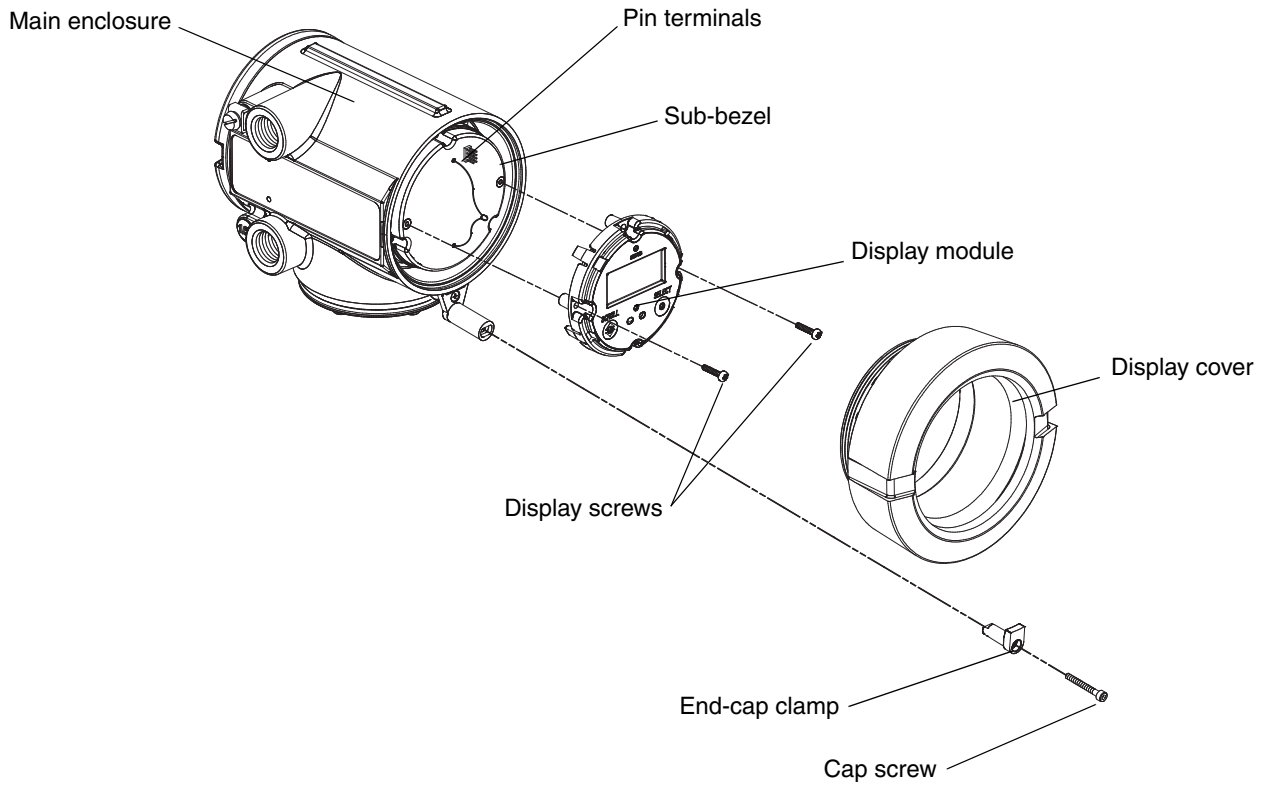

Chapter 3

Wiring the Transmitter to the Sensor

3.1 Overview

This chapter describes how to connect Micro Motion Model 1700 and 2700 transmitters to a Micro Motion sensor.

Note: If you have an integral installation, this step is not required. Continue with wiring the transmitter outputs (Chapters 4–7).

Wiring requirements between the sensor and transmitter depend on the installation type (see Figure 2-1).

- If you have a 4-wire remote transmitter installation, review the information on 4-wire cable in Section 3.2, then follow the instructions in Section 3.3.
- If you have a 9-wire remote transmitter installation, review the information on 9-wire cable in Section 3.2, then follow the instructions in Section 3.4.
- If you have a remote core processor with remote transmitter installation, review the information on both 4-wire and 9-wire cable in Section 3.2, then follow the instructions in Section 3.5.

CAUTION

Large electromagnetic fields can interfere with flowmeter communication signals.

Improper installation of cable or conduit can cause measurement error or flowmeter failure. To reduce the risk of measurement error or flowmeter failure, keep cable or conduit away from devices such as transformers, motors, and power lines which produce large electromagnetic fields.

3.2 Cable types

This section describes the types of 4-wire cable and 9-wire cable that can be used for wiring the transmitter to the sensor.

Wiring the Transmitter to the Sensor

3.2.1 4-wire cable

Micro Motion offers two types of 4-wire cable: shielded and armored. Both types contain shield drain wires.

User-supplied 4-wire cable must meet the following requirements:

- Twisted pair construction
- The gauge requirements as described in Table 2-2
- The applicable hazardous area requirements, if the core processor is installed in a hazardous area (see the approval documentation shipped with the transmitter or available on the Micro Motion web site)

3.2.2 9-wire cable

Micro Motion offers three types of 9-wire cable: jacketed, shielded, and armored. Refer to Micro Motion's *9-Wire Flowmeter Cable Preparation and Installation Guide* for detailed descriptions of these cable types and for assistance in selecting the appropriate cable for your installation.

3.3 Wiring for 4-wire remote installations

To connect the cable, follow the steps below.

1. Prepare the cable as described in the sensor documentation.
2. Connect the cable to the core processor as described in the sensor documentation.
3. To connect the cable to the transmitter:
 - a. Identify the wires in the 4-wire cable. The 4-wire cable supplied by Micro Motion consists of one pair of 18 AWG (0,75 mm²) wires (red and black), which should be used for the VDC connection, and one pair of 22 AWG (0,35 mm²) wires (green and white), which should be used for the RS-485 connection.
 - b. Connect the four wires from the core processor to terminals 1–4 on the mating connector of the transmitter. See Figures 3-1, 3-2, and 3-3. Never ground the shield, braid, or drain wire(s) at the transmitter.

Figure 3-1 4-wire cable between enhanced core processor and transmitter

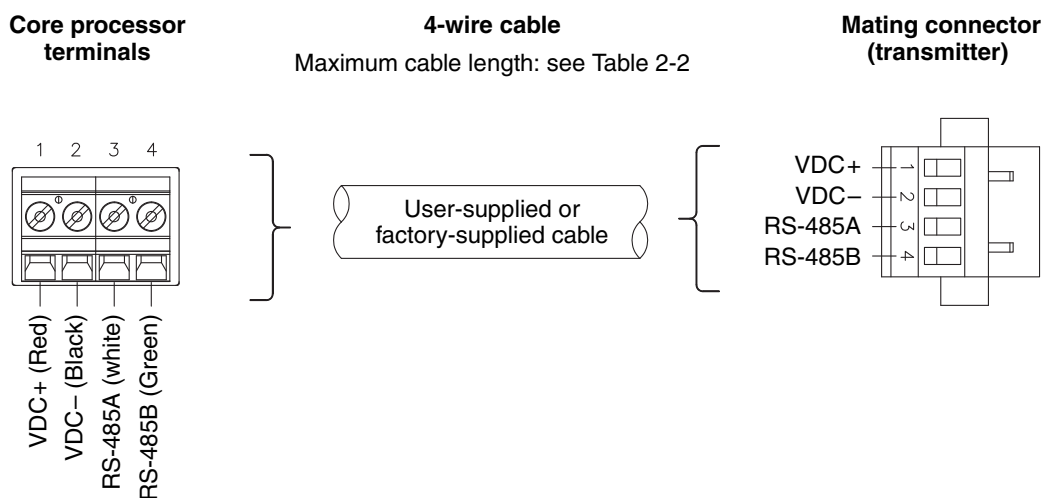

Wiring the Transmitter to the Sensor

Figure 3-2 4-wire cable between standard core processor and transmitter

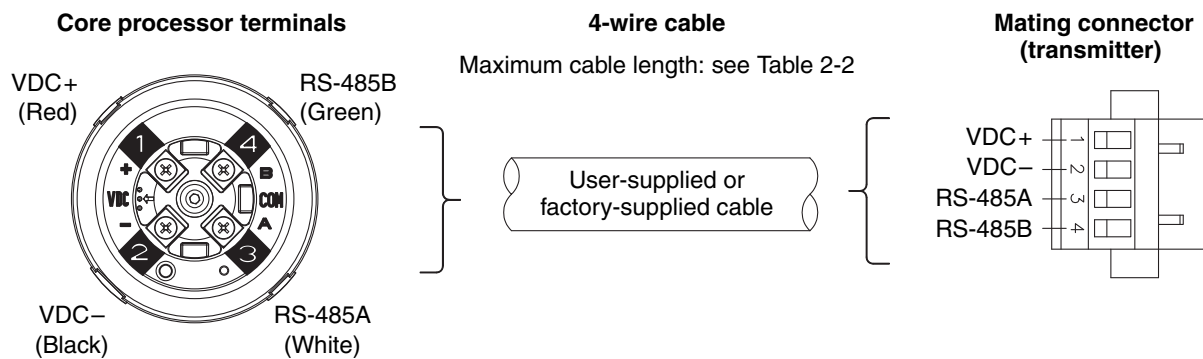
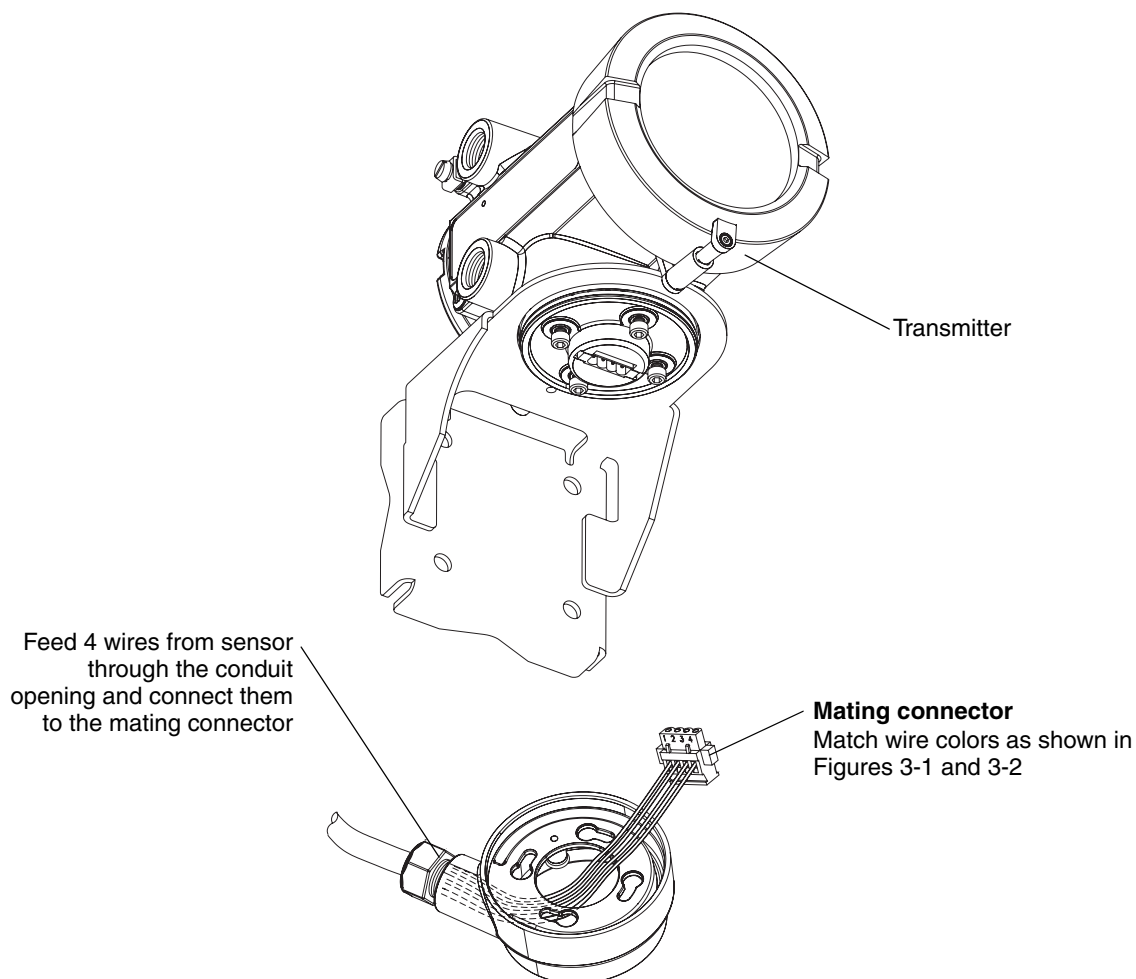

Figure 3-3 Wiring to the mating connector



Wiring the Transmitter to the Sensor

3.4 Wiring for 9-wire remote installations

If you chose a 9-wire remote installation (see Figure 2-1), a 9-wire cable must be used to connect the junction box on the sensor to the core processor on the transmitter/core processor assembly.

⚠ CAUTION

Allowing the shield drain wires to contact the sensor junction box can cause flowmeter errors.

Do not allow the shield drain wires to contact the sensor junction box.

To connect the cable, follow the steps below:

1. Refer to Micro Motion's *9-Wire Flowmeter Cable Preparation and Installation Guide* for instructions on cable shielding and preparation:
 - At the sensor end, follow the instructions for your cable type.
 - At the transmitter end, follow the instructions for your cable type with an MVD transmitter.
2. To connect the wires, refer to Micro Motion's *9-Wire Flowmeter Cable Preparation and Installation Guide* and follow the instructions for your sensor with an MVD transmitter. Additional information for connecting the wires at the transmitter is provided below:
 - a. Identify the components shown in Figure 2-6.
 - b. Remove the end-cap.
 - c. Insert the 9-wire cable through the conduit opening.
 - d. Connect the wires to the plugs supplied with the transmitter.
 - e. Insert the plugs into the sockets inside the lower conduit ring. See Figure 3-4.

Figure 3-4 9-wire cable between sensor and core processor (on transmitter)

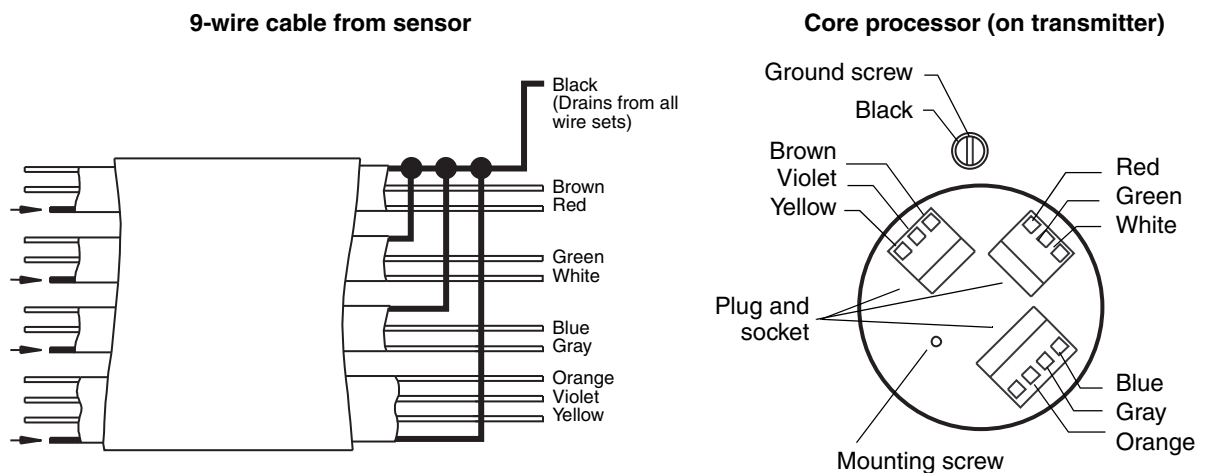

3. Ground the cable.

Wiring the Transmitter to the Sensor

If using jacketed cable:

- a. Ground the shield drain wires (the black wire) only on the core processor end, by connecting it to the ground screw inside the lower conduit ring. Never ground to the core processor's mounting screw. Never ground the shield drain wires at the sensor junction box.

If using shielded or armored cable:

- a. Ground the shield drain wires (the black wire) only on the core processor end, by connecting it to the ground screw inside the lower conduit ring. Never ground to the core processor's mounting screw. Never ground the shield drain wires at the sensor junction box.
 - b. Ground the cable braid on both ends, by terminating it inside the cable glands.
4. Ensure integrity of gaskets, grease all O-rings, then close the junction box housing and core processor end-cap, and tighten all screws.

CAUTION

Damaging the wires that connect the transmitter to the sensor can cause measurement error or flowmeter failure.

To reduce the risk of measurement error or flowmeter failure, when closing the housings on the sensor and core processor, make sure that the wires are not caught or pinched.

3.5 Wiring for remote core processor with remote transmitter installations

This task includes two subtasks:

- Subtask 1: Wiring the remote core processor to the transmitter (4-wire cable)
- Subtask 2: Wiring the sensor to the remote core processor (9-wire cable)

Subtask 1: Wire the remote core processor to the transmitter

1. Use one of the following methods to shield the wiring from the core processor to the transmitter:
 - If you are installing unshielded wiring in continuous metallic conduit that provides 360° termination shielding for the enclosed wiring, go to Subtask 1, Step 6.
 - If you are installing a user-supplied cable gland with shielded cable or armored cable, terminate the shields in the cable gland. Terminate both the armored braid and the shield drain wires in the cable gland. Go to Subtask 1, Step 6.
 - If you are installing a Micro Motion-supplied cable gland at the core processor housing:
 - Refer to Figure 3-5 to identify the cable gland to use for the 4-wire cable conduit opening.
 - Prepare the cable and apply shielded heat shrink to the cable (see Figure 3-6). The shielded heat shrink provides a shield termination suitable for use in the gland when using cable whose shield consists of foil and not a braid. Proceed to Subtask 1, Step 2.
 - With armored cable, where the shield consists of braid, prepare the cable as described below, but do not apply heat shrink. Proceed to Subtask 1, Step 2.

Wiring the Transmitter to the Sensor

Figure 3-5 Cable glands

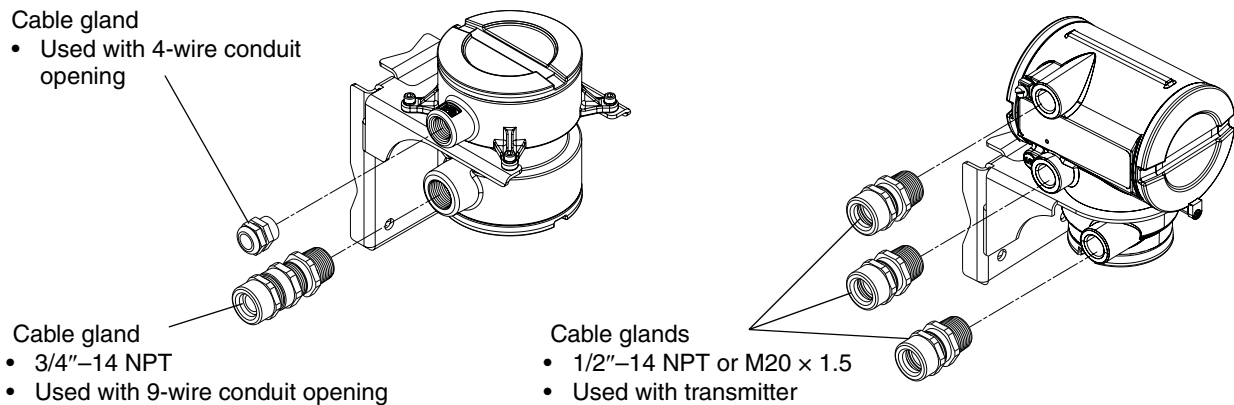

2. Remove the cover from the core processor housing.
3. Slide the gland nut and the clamping insert over the cable.

Figure 3-6 Micro Motion cable gland and heat shrink

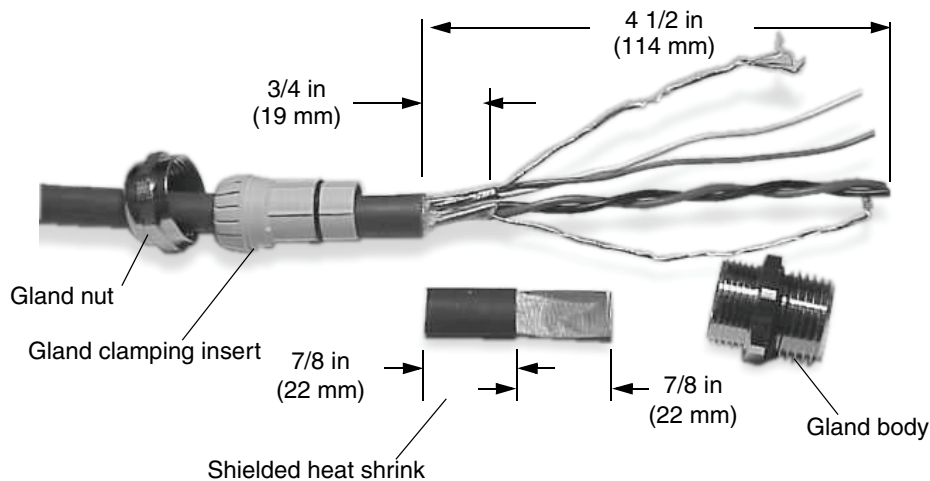

4. For connection at the core processor housing, prepare shielded cable as follows (for armored cable, omit steps d, e, f, and g):
 - a. Strip 4 1/2 inches (114 mm) of cable jacket.
 - b. Remove the clear wrap that is inside the cable jacket, and remove the filler material between the wires.
 - c. Remove the foil shield or braid and drain wires from the insulated wires, leaving 3/4 inch (19 mm) of foil or braid exposed, and separate the wires.
 - d. Wrap the shield drain wire(s) around the exposed foil twice. Cut off the excess wire. See Figure 3-7.

Wiring the Transmitter to the Sensor

Figure 3-7 Wrapping the shield drain wires

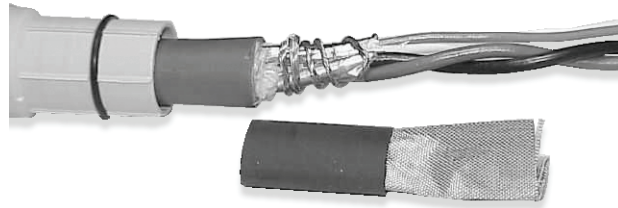

- e. Place the shielded heat shrink over the exposed shield drain wire(s). The tubing should completely cover the drain wires. See Figure 3-8.
- f. Without burning the cable, apply heat (250 °F or 120 °C) to shrink the tubing.

Figure 3-8 Applying the heat shrink



- g. Position gland clamping insert so the interior end is flush with the heat shrink.
- h. Fold the cloth shield or braid and drain wires over the clamping insert and approximately 1/8 inch (3 mm) past the O-ring. See Figure 3-9.

Figure 3-9 Folding the cloth shield

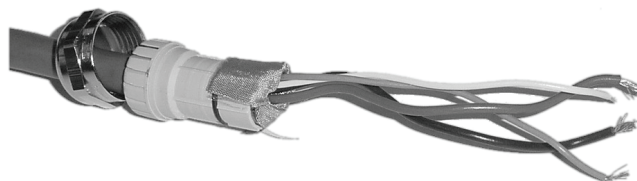

- i. Install the gland body into the core processor housing conduit opening. See Figure 3-10.

Wiring the Transmitter to the Sensor

Figure 3-10 Gland body and core processor housing



5. Insert the wires through the gland body and assemble the gland by tightening the gland nut.
6. Identify the wires in the 4-wire cable. The 4-wire cable supplied by Micro Motion consists of one pair of 18 AWG (0,75 mm²) wires (red and black), which should be used for the VDC connection, and one pair of 22 AWG (0,35 mm²) wires (green and white), which should be used for the RS-485 connection. Connect the four wires to the numbered slots on the core processor, matching corresponding numbered terminals on the transmitter. See Figure 3-11.

Figure 3-11 Connecting the wires at the core processor

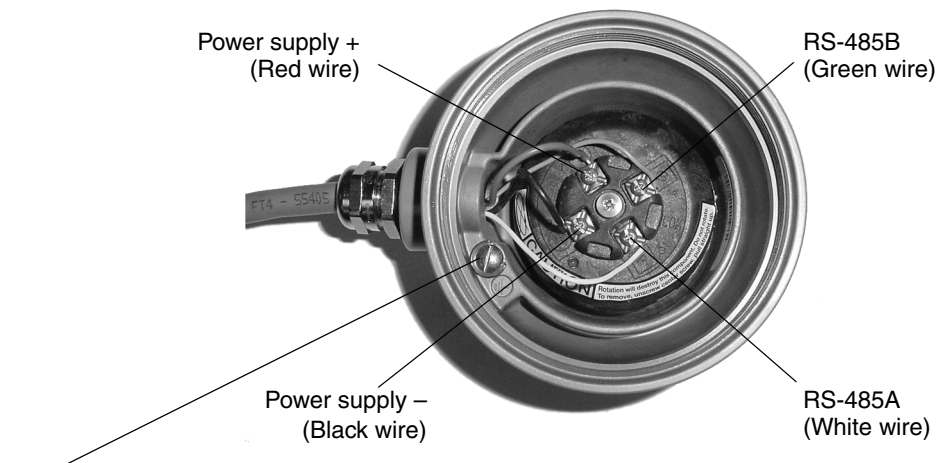

Core processor housing internal ground screw

- For connections to earth ground (if core processor cannot be grounded via sensor piping and local codes require ground connections to be made internally)
- Do not connect shield drain wires to this terminal

7. Reinstall and tighten the core processor housing cover.

⚠ CAUTION

Twisting the core processor will damage the equipment.

Do not twist the core processor.

Wiring the Transmitter to the Sensor

- At the transmitter, connect the four wires from the core processor to terminals 1–4 on the mating connector of the transmitter. See Figure 3-2. Never ground the shield, braid, or shield drain wire(s) at the transmitter. Refer to Figure 2-4.

Subtask 2: Wiring the sensor to the remote core processor

⚠ CAUTION

Allowing the shield drain wires to contact the sensor junction box can cause flowmeter errors.

Do not allow the shield drain wires to contact the sensor junction box.

- Refer to Micro Motion's *9-Wire Flowmeter Cable Preparation and Installation Guide* for instructions on cable shielding and preparation:
 - At the sensor end, follow the instructions for your cable type.
 - At the core processor end, follow the instructions for your cable type with an MVD transmitter.
- To connect the wires, refer to Micro Motion's *9-Wire Flowmeter Cable Preparation and Installation Guide* and follow the instructions for your sensor with an MVD transmitter. Additional information for connecting the wires at the core processor is provided below:
 - Identify the components shown in Figure 2-8.
 - Remove the end-cap.
 - Insert the 9-wire cable through the conduit opening.
 - Connect the wires to the plugs supplied with the core processor.
 - Insert the plugs into the sockets inside the lower conduit ring. See Figure 3-12.

Figure 3-12 9-wire cable between sensor and core processor

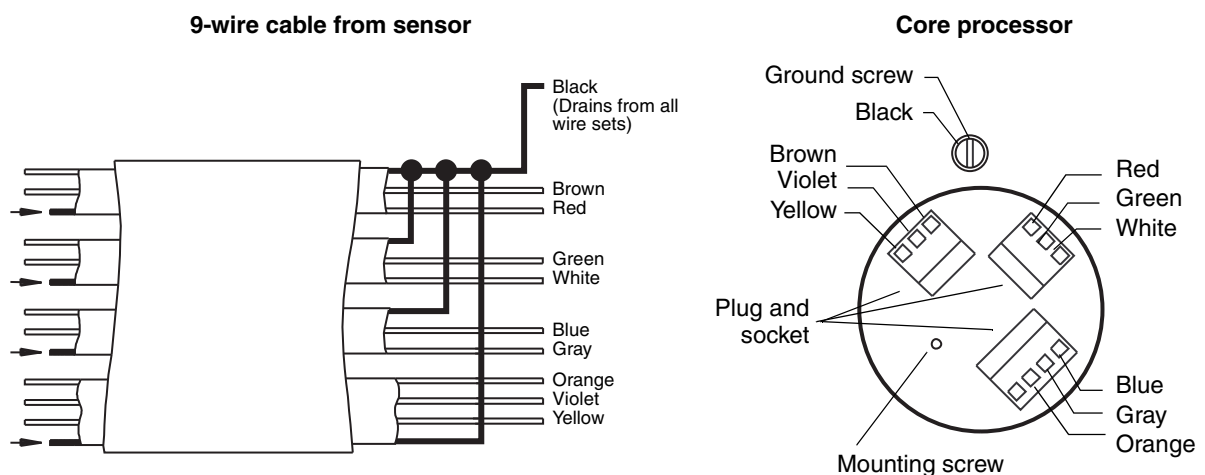

- Ground the cable.

Wiring the Transmitter to the Sensor

If using jacketed cable:

- a. Ground the shield drain wires (the black wire) only on the core processor end, by connecting it to the ground screw inside the lower conduit ring. Never ground to the core processor's mounting screw. Never ground the cable at the sensor junction box.

If using shielded or armored cable:

- a. Ground the shield drain wires (the black wire) only on the core processor end, by connecting it to the ground screw inside the lower conduit ring. Never ground to the core processor's mounting screw. Never ground the cable at the sensor junction box.
 - b. Ground the cable braid on both ends, by terminating it inside the cable glands.
4. Ensure integrity of gaskets, grease all O-rings, then close the junction box housing and core processor end-cap, and tighten all screws.

CAUTION

Damaging the wires that connect the transmitter to the sensor can cause measurement error or flowmeter failure.

To reduce the risk of measurement error or flowmeter failure, when closing the housings on the sensor and core processor, make sure that the wires are not caught or pinched.

Chapter 4

Output Wiring – Model 1700/2700

Analog Transmitters

4.1 Overview

This chapter explains how to wire outputs for Model 1700 or 2700 transmitters with the analog outputs option board (output option code A).

Note: If you do not know what outputs option board is in your transmitter, see Section 1.4.

It is the user's responsibility to verify that the specific installation meets the local and national safety requirements and electrical codes.

4.2 Output terminals and output types

Table 4-1 describes the outputs and communication protocols available for the Model 1700 or 2700 analog transmitter.

Table 4-1 Terminals and output types

Terminals	Model 1700 output type	Model 2700 output type	Communication
1 & 2	Milliamp/Bell 202 ⁽¹⁾	Milliamp/Bell 202 ⁽¹⁾	HART
3 & 4	Frequency	<ul style="list-style-type: none"> • Frequency (default) • Discrete 	None
5 & 6	RS-485	RS-485	<ul style="list-style-type: none"> • HART (default) • Modbus

(1) The Bell 202 signal is superimposed on the mA output.

4.3 Output wiring

Output wiring requirements depend on how you will use the analog functionality and the HART or Modbus protocol. This chapter describes several possible configurations:

- Figure 4-1 shows the wiring requirements for the mA output (terminals 1 and 2) and the frequency output (terminals 3 and 4).
- Figure 4-2 shows the wiring requirements for the mA output (terminals 1 and 2) if it will be used for HART communications in addition to the mA signal.
- Figure 4-3 shows the wiring requirements for RS-485 communications using the RS-485 output (terminals 5 and 6).
- Figure 4-4 shows the wiring requirements for connecting the transmitter to a HART multidrop network.

Output Wiring – Model 1700/2700 Analog Transmitters

Note: If you will configure the transmitter to poll an external temperature or pressure device, you must wire the mA output to support HART communications. You may use either HART/analog single-loop wiring or HART multidrop wiring.

It is the user's responsibility to verify that the specific installation meets the local and national safety requirements and electrical codes.

Figure 4-1 Basic analog wiring

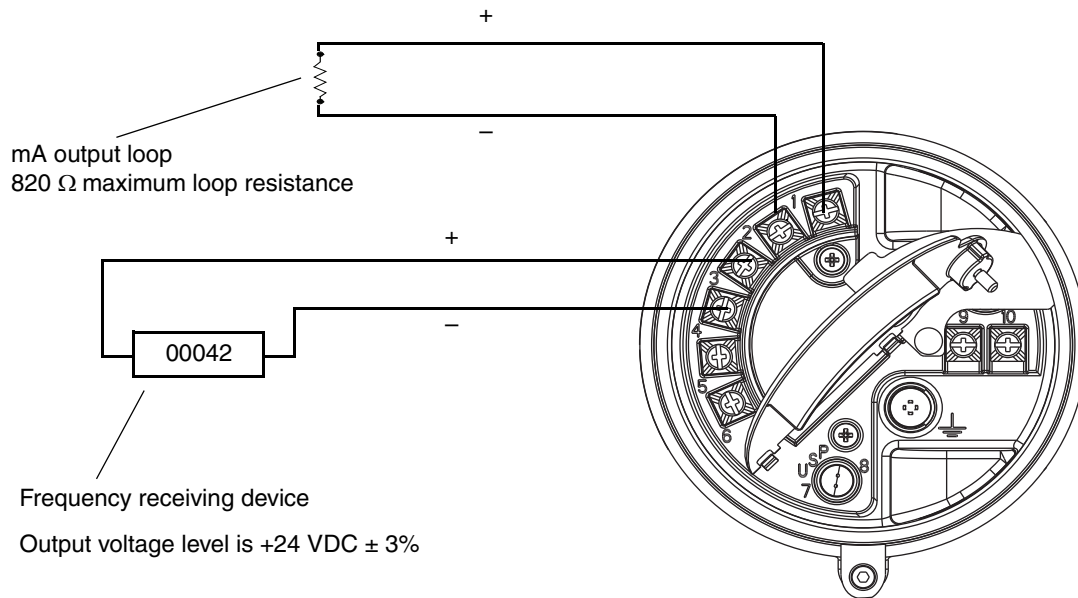

Figure 4-2 HART/analog single-loop wiring

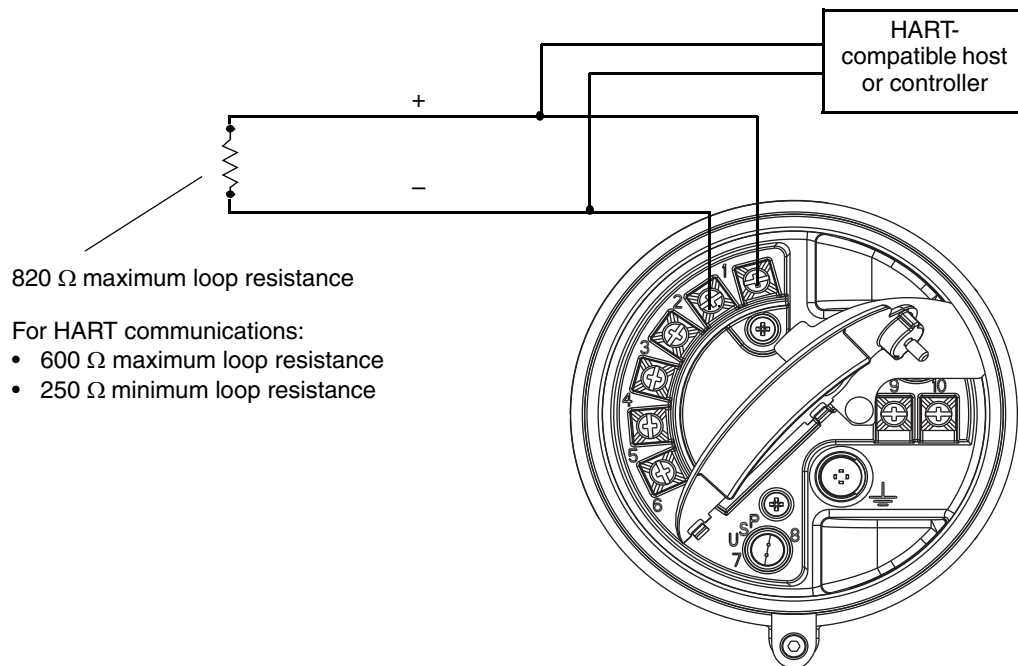
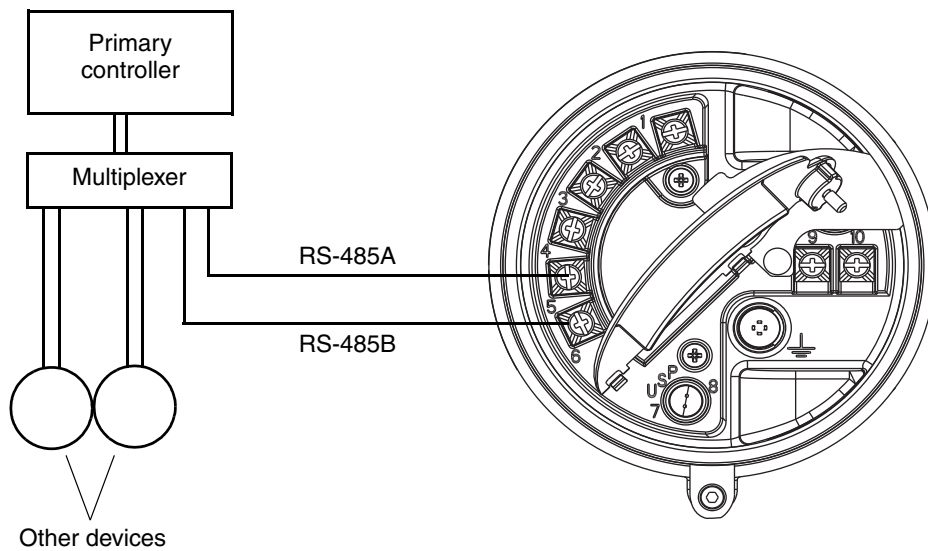

Figure 4-3 RS-485 point-to-point wiring



Note: The RS-485 communication wires must be shielded.

Output Wiring – Model 1700/2700 Analog Transmitters

Figure 4-4 HART multidrop wiring with SMART FAMILY™ transmitters and a configuration tool

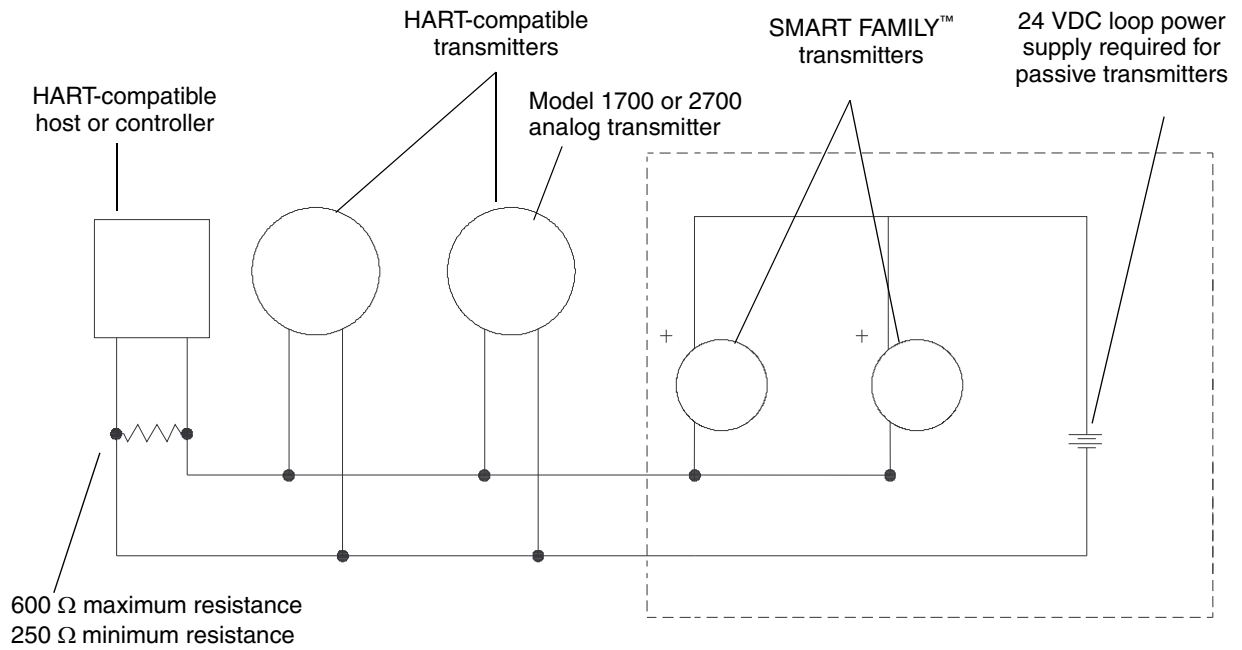

Note: For optimum HART communication, make sure the output loop is single-point-grounded to an instrument-grade ground.

Chapter 5

Output Wiring – Model 1700/2700 Intrinsically Safe Transmitters

5.1 Overview

This chapter explains how to wire outputs for Model 1700 or 2700 transmitters with the intrinsically safe outputs option board (output option code D).

Note: If you do not know what outputs option board is in your transmitter, see Section 1.4.

Intrinsically safe outputs require external power. “External power” means that the terminals must be connected to an independent power supply. The output wiring instructions include power setup and power wiring.

Note: The term “passive” is sometimes used to describe externally powered outputs.

Output wiring requirements depend on whether the transmitter will be installed in a safe area or a hazardous area. This chapter describes several possible configurations:

- Section 5.3 describes wiring requirements for the outputs if the transmitter will be installed in a safe area.
- Section 5.4 describes wiring requirements for the outputs if the transmitter will be installed in a hazardous area.

It is the user’s responsibility to verify that the specific installation meets the local and national safety requirements and electrical codes.

5.2 Output terminals and output types

Table 5-1 describes the outputs and communication protocols available for the Model 1700 or 2700 intrinsically safe transmitter.

Table 5-1 Terminals and output types

Terminals	Model 1700 output type	Model 2700 output type	Communication
1 & 2	Milliamp/Bell 202 ⁽¹⁾	Milliamp/Bell 202 ⁽¹⁾	HART
3 & 4	Frequency	<ul style="list-style-type: none"> • Frequency (default) • Discrete 	None
5 & 6	Not used	Milliamp	None

(1) The Bell 202 signal is superimposed on the mA output.

Note: If you will configure the transmitter to poll an external temperature or pressure device, you must wire the mA output to support HART communications. You may use either HART/analog single-loop wiring or HART multidrop wiring.

Output Wiring – Model 1700/2700 Intrinsically Safe Transmitters

5.3 Safe area output wiring

The following notes and diagrams are designed to be used as a guide for wiring the Model 1700 or Model 2700 outputs for safe area applications.

5.3.1 Safe area mA output wiring

The following 4–20 mA wiring diagrams are examples of proper basic wiring for the Model 1700 mA output or Model 2700 primary and secondary mA outputs.

Note: This diagram shows the Model 2700, which has a secondary mA output. If you are using the Model 1700, the secondary mA output does not exist.

Figure 5-1 Safe area basic mA output wiring

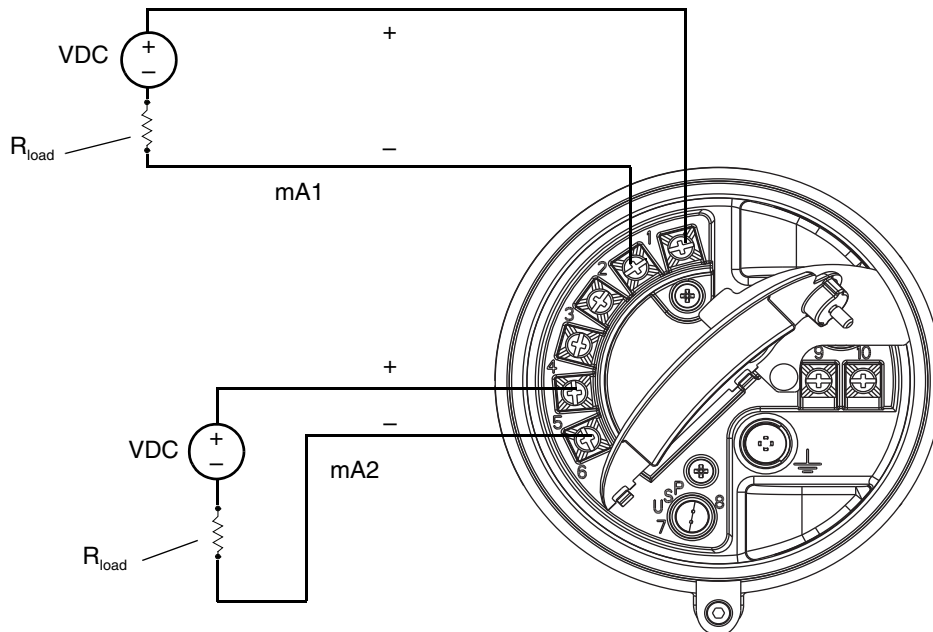

Note: See Figure 5-2 for voltage and resistance values.

Figure 5-2 Safe area mA output load resistance values

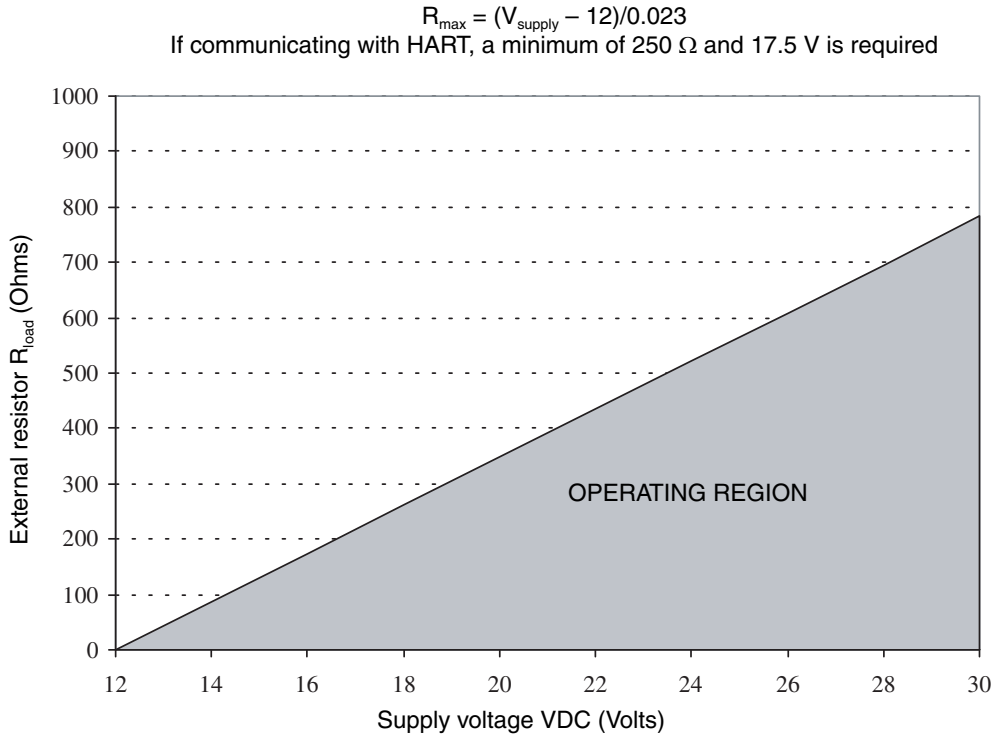
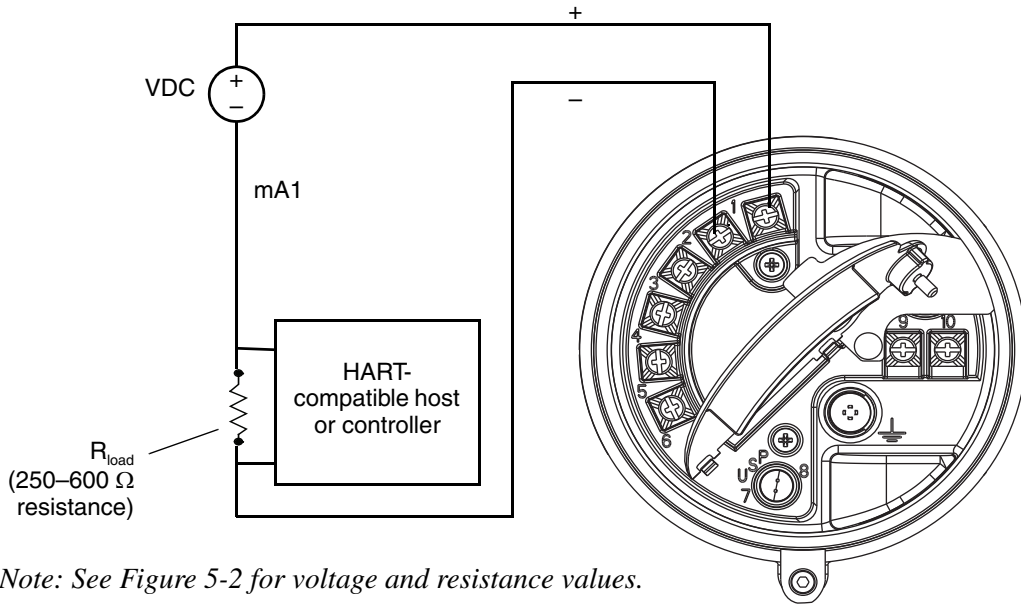
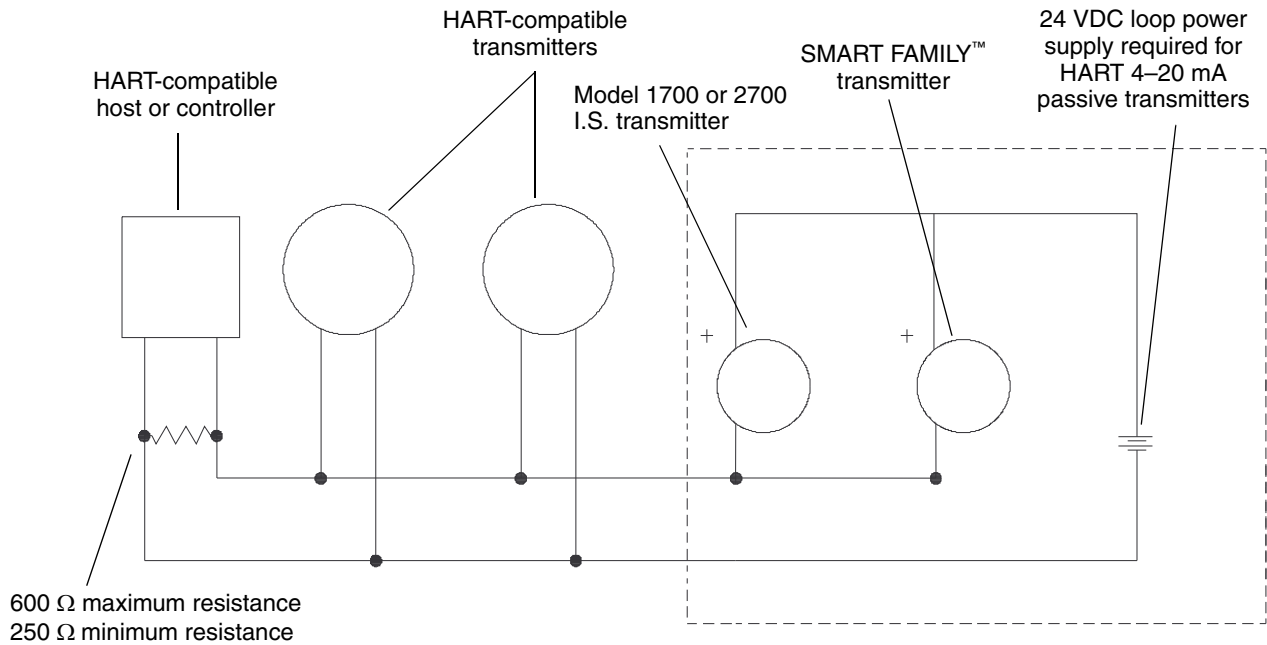

Figure 5-3 Safe area HART/analog single-loop wiring



Output Wiring – Model 1700/2700 Intrinsically Safe Transmitters

Figure 5-4 Safe area HART multidrop wiring with SMART FAMILY™ transmitters and a configuration tool



Note: For optimum HART communication, make sure the output loop is single-point-grounded to an instrument-grade ground.

5.3.2 Safe area frequency/discrete output wiring

The following frequency/discrete output wiring diagram is an example of proper basic wiring for the Model 1700 transmitter's frequency output or the Model 2700 transmitter's frequency/discrete output.

Figure 5-5 Safe area frequency/discrete output wiring

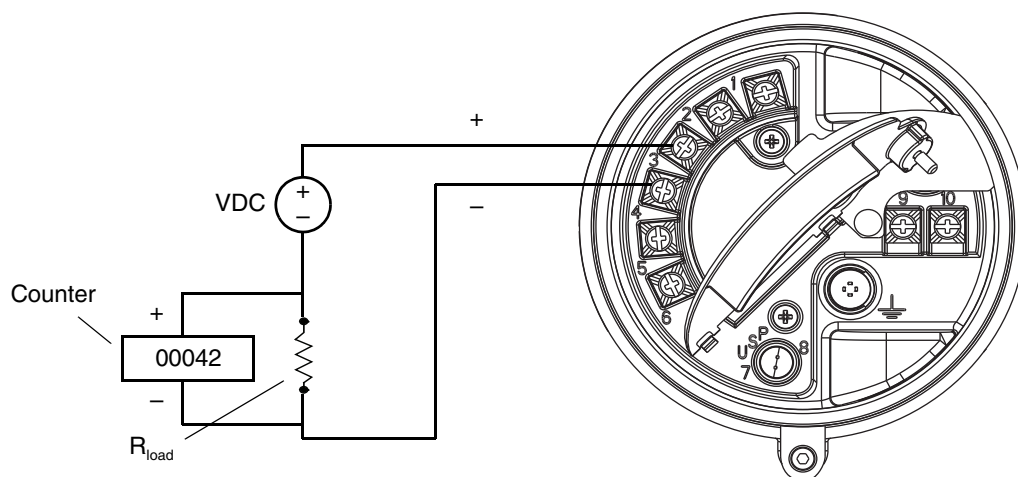

Note: See Figure 5-6 for voltage and resistance values.

Figure 5-6 Safe area frequency/discrete output load resistance values

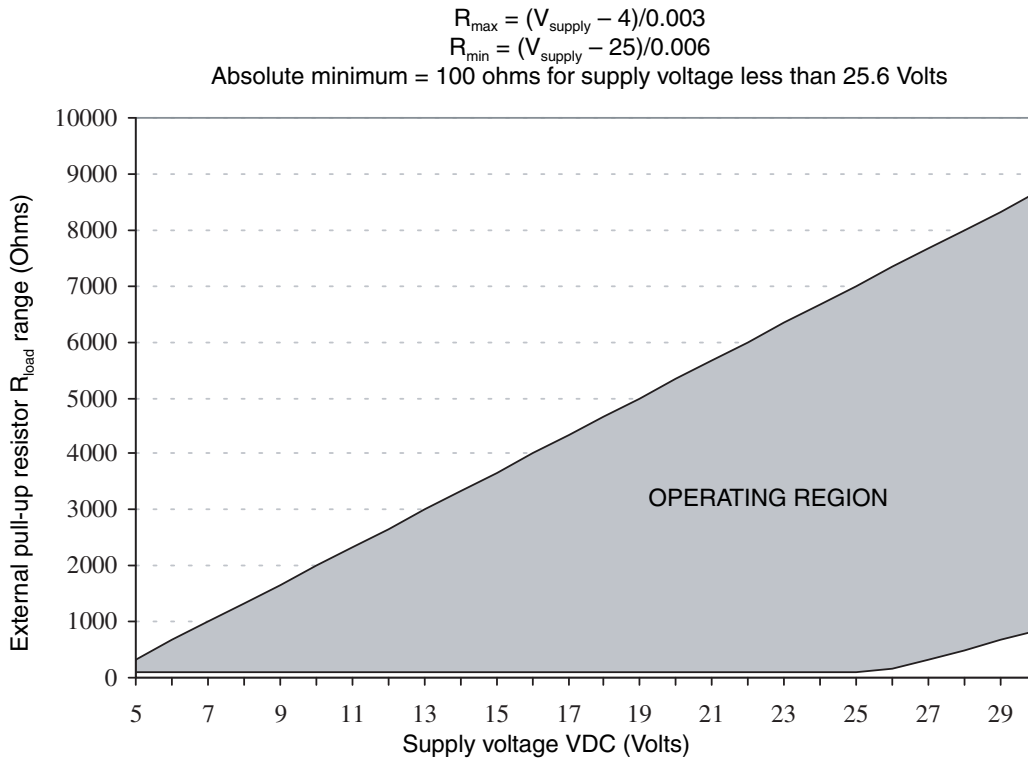

5.4 Hazardous area output wiring

The following notes and diagrams are designed to be used as a guide for wiring the Model 1700 or Model 2700 outputs for hazardous area applications.

5.4.1 Hazardous area safety parameters

The proper barrier selection will depend on what output is desired, which approval is applicable, and many installation-specific parameters. The information that is provided about I.S. barrier selection is intended as an overview. Refer to barrier manufacturers for more detailed information regarding the use of their products. Application-specific questions should be addressed to the barrier manufacturer or to Micro Motion.

⚠ WARNING

Hazardous voltage can cause severe injury or death.

To reduce the risk of hazardous voltage, shut off the power before wiring the transmitter outputs.

⚠ WARNING	
A transmitter that has been improperly wired or installed in a hazardous area could cause an explosion.	
To reduce the risk of an explosion:	
<ul style="list-style-type: none"> • Make sure the transmitter is wired to meet or exceed local code requirements. • Install the transmitter in an environment that complies with the classification tag on the transmitter. See Appendix A. 	

Table 5-2 Safety parameters

Parameter	Value	
	4–20 mA output	Frequency/discrete output
Voltage (U _i)	30 V	30 V
Current (I _i)	300 mA	100 mA
Power (P _i)	1.0 W	0.75 W
Capacitance (C _i)	0.0005 μF	0.0005 μF
Inductance (L _i)	0.0 mH	0.0 mH

Hazardous area voltage

The Model 1700 or 2700 transmitter’s safety parameters require the selected barrier’s open-circuit voltage to be limited to less than 30 VDC (V_{max} = 30 VDC). This voltage is the combination of the maximum safety barrier voltage (typically 28 VDC) plus an additional 2 VDC for HART communications when communicating in the hazardous area.

Hazardous area current

The Model 1700 or 2700 transmitter’s safety parameters require the selected barrier’s short-circuit currents to sum to less than 300 mA (I_{max} = 300 mA) for the milliamp outputs and 100 mA (I_{max} = 100 mA) for the frequency/discrete output.

Hazardous area capacitance

The capacitance (C_i) of the Model 1700 or 2700 transmitter is 0.0005 μF. This value added to the wire capacitance (C_{cable}) must be lower than the maximum allowable capacitance (C_a) specified by the I.S. barrier. Use the following equation to calculate the maximum length of the cable between the transmitter and the barrier:

$$C_i + C_{cable} \leq C_a$$

Hazardous area inductance

The inductance (L_i) of the Model 1700 or 2700 transmitter is 0.0 mH. This value plus the field wiring inductance (L_{cable}), must be lower than the maximum allowable inductance (L_a) specified by the I.S. barrier. The following equation can then be used to calculate the maximum cable length between the transmitter and the barrier:

$$L_i + L_{cable} \leq L_a$$

5.4.2 Hazardous area mA output wiring

Figure 5-7 provides an example of basic hazardous area wiring for the Model 1700 transmitter's mA output or the Model 2700 transmitter's primary mA output.

Figure 5-7 Hazardous area mA output wiring

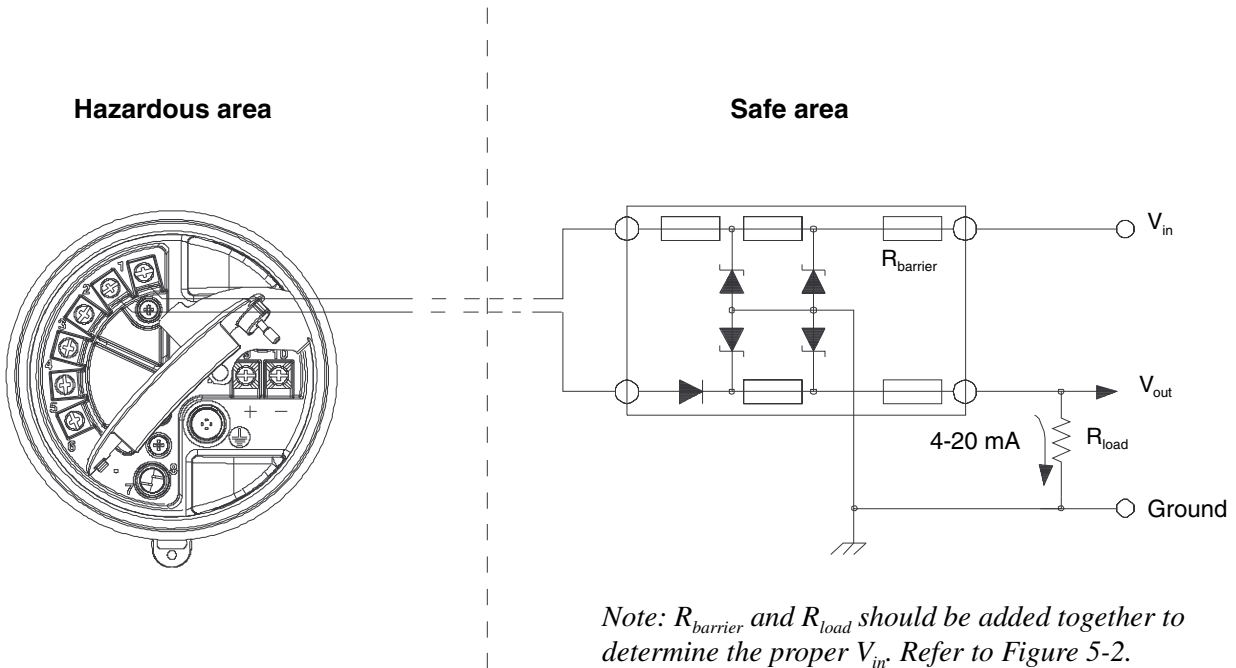

5.4.3 Hazardous area frequency/discrete output wiring

The following frequency/discrete output wiring diagrams are examples of proper hazardous area wiring for the Model 1700 transmitter's frequency output or the Model 2700 transmitter's frequency/discrete output:

- The diagram in Figure 5-8 utilizes a galvanic isolator that has an internal 1000 Ω resistor used for sensing current:
 - ON > 2.1 mA
 - OFF < 1.2 mA
- The diagram in Figure 5-9 utilizes a barrier with external load resistance.

Output Wiring – Model 1700/2700 Intrinsically Safe Transmitters

Figure 5-8 Hazardous area frequency/discrete output wiring using galvanic isolator

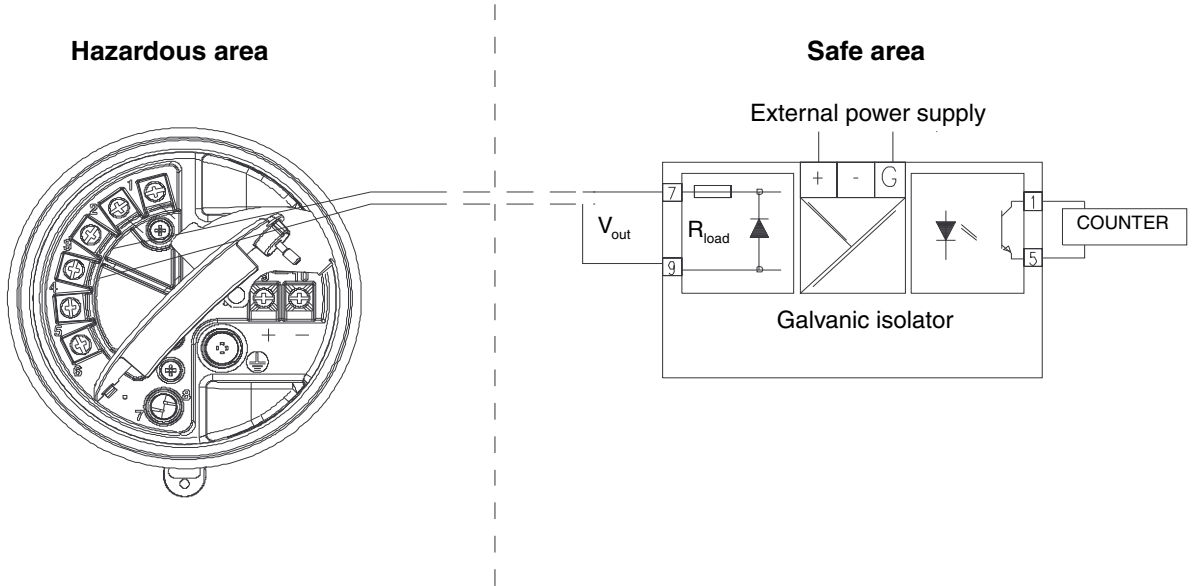
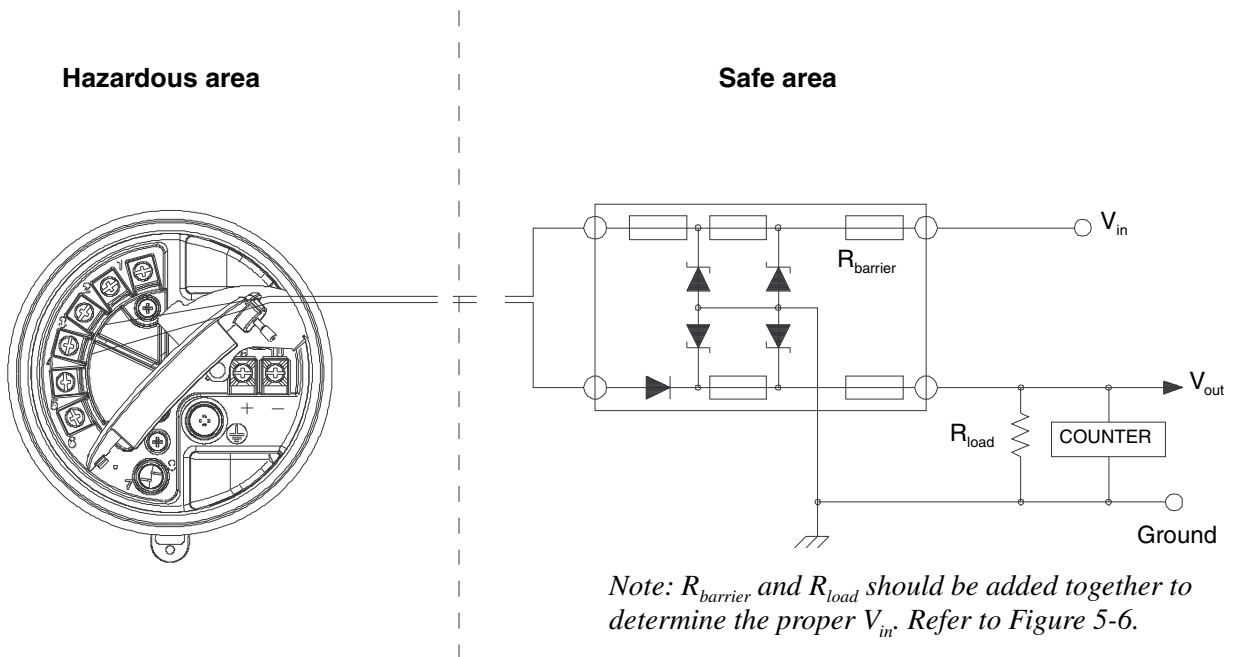

Figure 5-9 Hazardous area frequency/discrete output wiring using barrier with external load resistance



Chapter 6

Output Wiring – Model 2700 Configurable I/O Transmitters

6.1 Overview

This chapter explains how to wire outputs for Model 2700 transmitters with the configurable input/outputs board (output option code B or C).

Note: If you don't know what outputs option board is in your transmitter, see Section 1.4.

Output wiring requirements depend on how you will configure the transmitter terminals. The configuration options are shown in Table 6-1 and Figure 6-1.

If Channel B is configured as a frequency output or discrete output, it can also be configured to use either internal or external power. Channel C can be configured to use either internal or external power, independent of its output configuration.

- “Internal power” means that the terminals are powered automatically by the transmitter. The output wiring instructions do not include power setup and power wiring.
- “External power” means that the terminals must be connected to an independent power supply. The output wiring instructions include power setup and power wiring.

Note: The terms “active” and “passive” are sometimes used to describe internally and externally powered outputs.

It is the user's responsibility to verify that the specific installation meets the local and national safety requirements and electrical codes.

6.2 Channel configuration

The six terminals are divided into three pairs, and called Channels A, B, and C. Channel A is terminals 1 and 2; Channel B is terminals 3 and 4; and Channel C is terminals 5 and 6. Variable assignments are governed by channel configuration. Table 6-1 and Figure 6-1 show how each channel may be configured, and the power options for each channel.

You can use a HART Communicator or ProLink II software to configure channels. To configure channels, see the manual entitled *Series 1000 and 2000 Transmitters Configuration and Use Manual*.

Note: You cannot configure the following combination: Channel B = discrete output, Channel C = frequency output. If you need both a frequency output and a discrete output, use the following: Channel B = frequency output, Channel C = discrete output. For more information, see the manual entitled Series 1000 and 2000 Transmitters Configuration and Use Manual.

Output Wiring – Model 2700 Configurable I/O Transmitters

Table 6-1 Channel configuration

Channel	Terminals	Configuration options	Power
A	1 & 2	mA output with HART/Bell 202 ⁽¹⁾	Internal
B	3 & 4	• mA output (default)	Internal
		• Frequency output	Internal or external ⁽²⁾
		• Discrete output	Internal or external
C	5 & 6	• Frequency output (default) ⁽³⁾	Internal or external
		• Discrete output	Internal or external
		• Discrete input	Internal or external

(1) The Bell 202 signal is superimposed on the mA output.

(2) You must provide power to the outputs when a channel is set to external power.

(3) When configured for two frequency outputs (dual pulse), frequency output 2 is generated from the same signal that is sent to the first frequency output. Frequency output 2 is electrically isolated but not independent.

Figure 6-1 Configuration of configurable I/O terminals

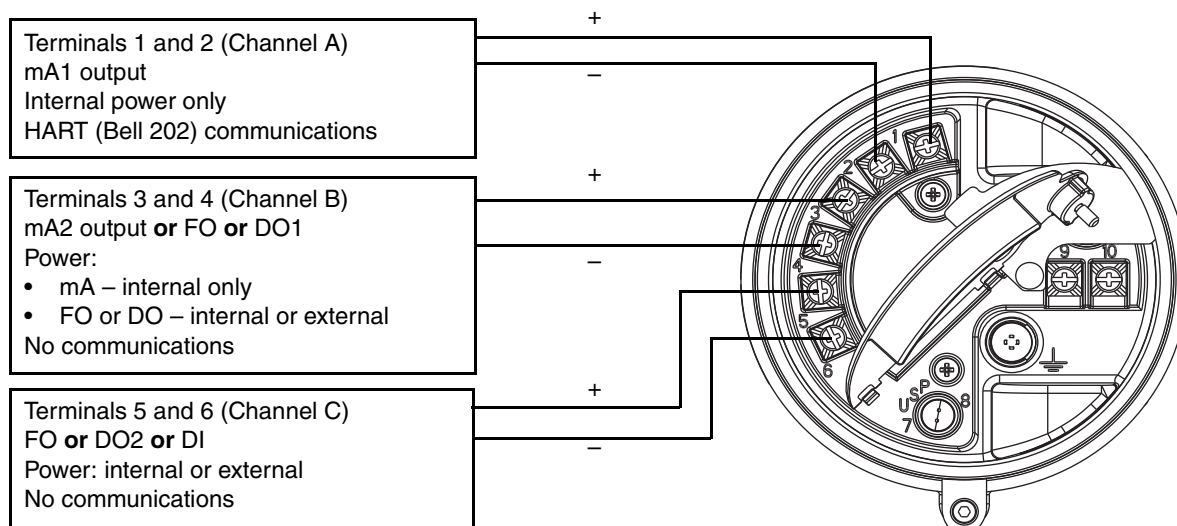

mA = milliamp
 FO = frequency output
 DO = discrete output
 DI = discrete input

6.3 mA output wiring

The following 4–20 mA wiring diagrams are examples of proper basic wiring for the Model 2700 primary and secondary mA outputs. The following options are shown:

- Basic mA wiring (Figure 6-2)
- HART/analog single-loop wiring (Figure 6-3)
- HART multidrop wiring (Figure 6-4)

Note: If you will configure the transmitter to poll an external temperature or pressure device, you must wire the mA output to support HART communications. You may use either HART/analog single-loop wiring or HART multidrop wiring.

Figure 6-2 Basic mA wiring

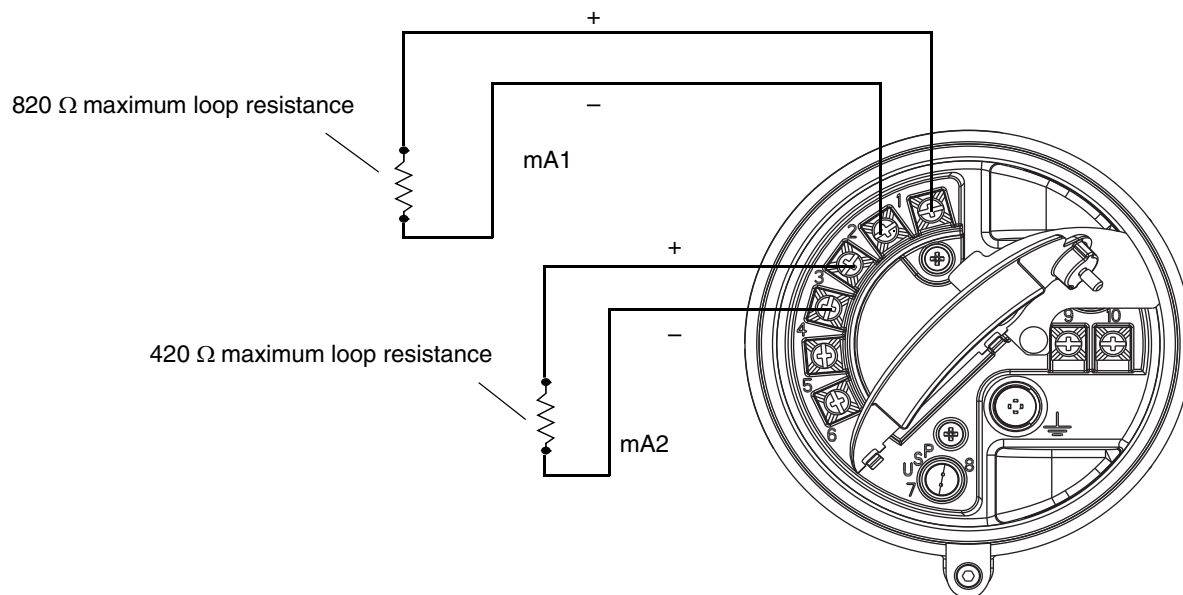
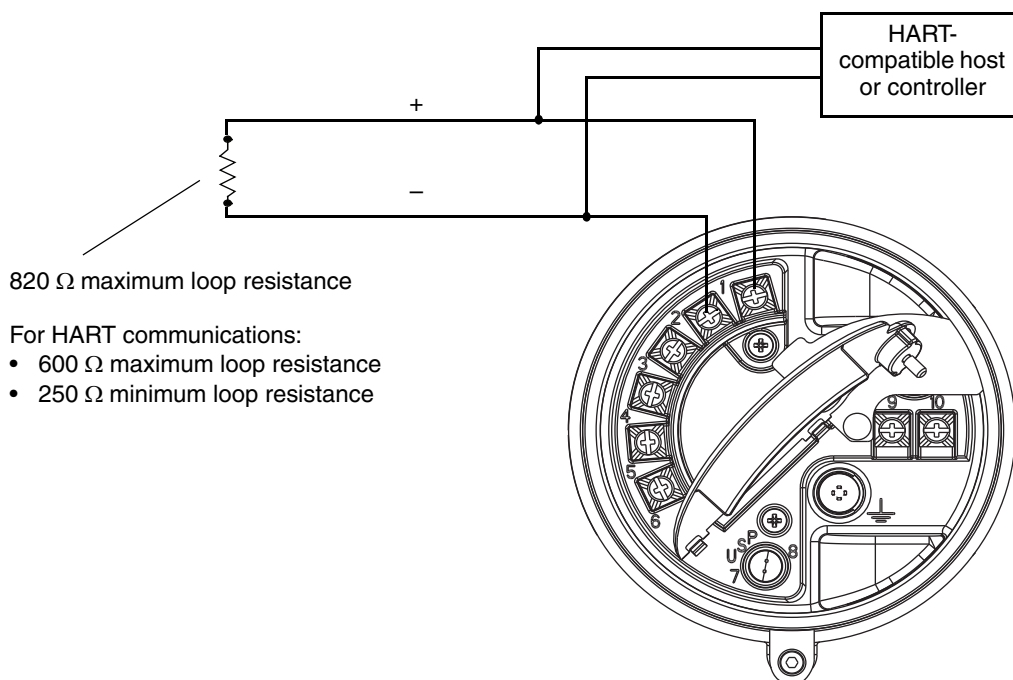
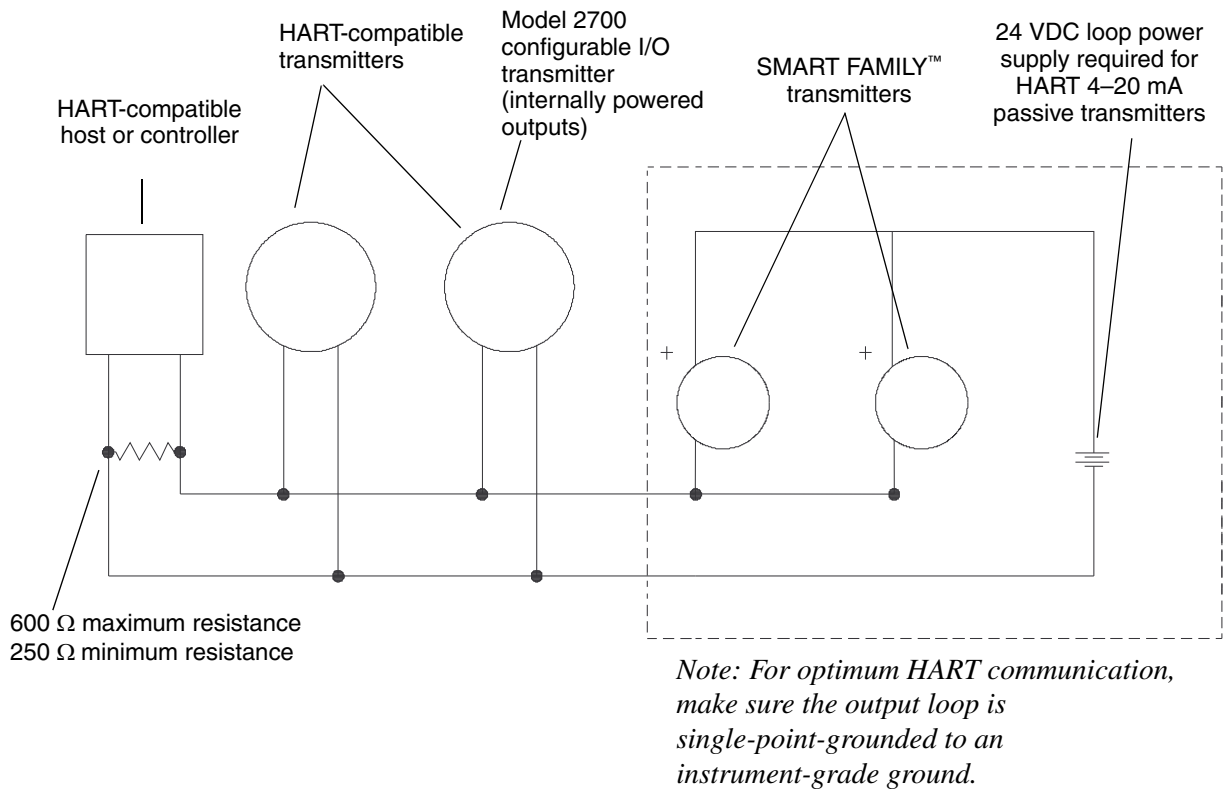

Figure 6-3 HART/analog single-loop wiring



Output Wiring – Model 2700 Configurable I/O Transmitters

Figure 6-4 HART multidrop wiring with SMART FAMILY™ transmitters and a configuration tool



6.4 Frequency output wiring

Frequency output wiring depends on whether you are wiring terminals 3 and 4 (Channel B) or terminals 5 and 6 (Channel C), and also on whether you have configured the terminals for internal or external power. The following diagrams are examples of proper wiring for these configurations:

- Channel B, internal power – Figure 6-5
- Channel B, external power – Figure 6-6
- Channel C, internal power – Figure 6-7
- Channel C, external power – Figure 6-8

Note: If both Channel B and Channel C are configured for frequency output, the Channel C signal is generated from the Channel B signal, with a user-specified phase shift. The signals are electrically isolated but not independent. This configuration is used to support dual-pulse and quadrature modes. For more information, see the manual entitled Series 1000 and 2000 Transmitters Configuration and Use Manual.

Figure 6-5 Frequency output – Terminals 3 & 4 (Channel B) – Internal power

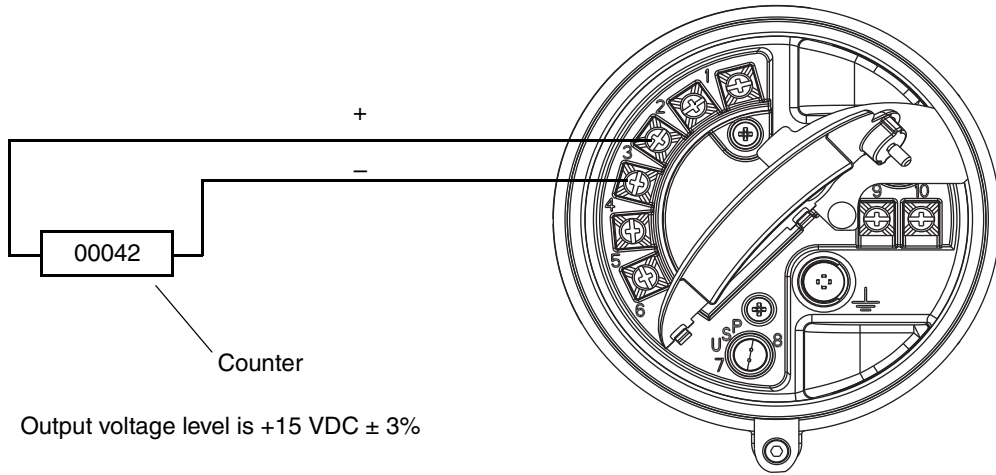

Note: See Figure 6-13 for output voltage versus load resistance.

Figure 6-6 Frequency output – Terminals 3 & 4 (Channel B) – External power

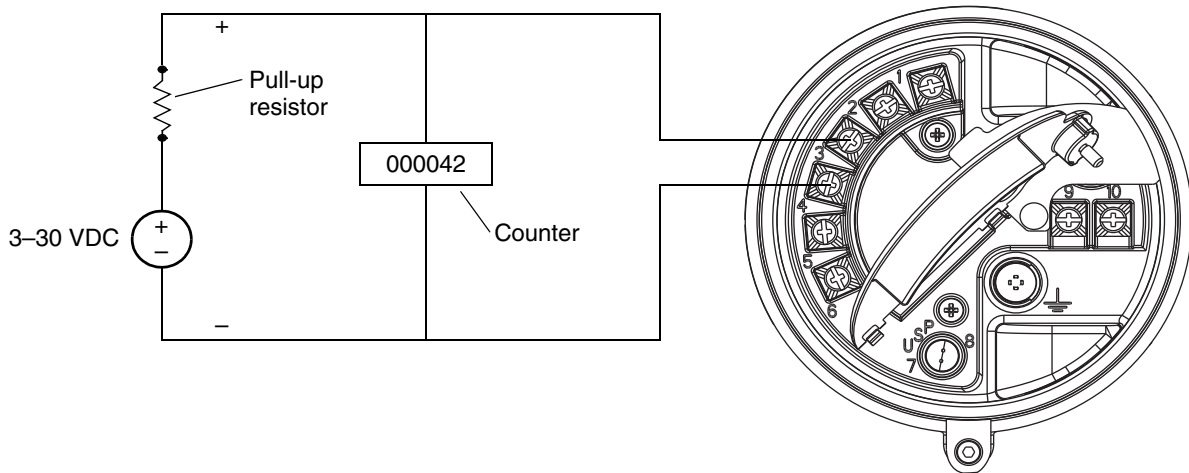

Note: See Figure 6-15 for recommended resistor versus supply voltage.

⚠ CAUTION

Excessive current will damage the transmitter.

Do not exceed 30 VDC input. Terminal current must be less than 500 mA.

Output Wiring – Model 2700 Configurable I/O Transmitters

Figure 6-7 Frequency output – Terminals 5 & 6 (Channel C) – Internal power

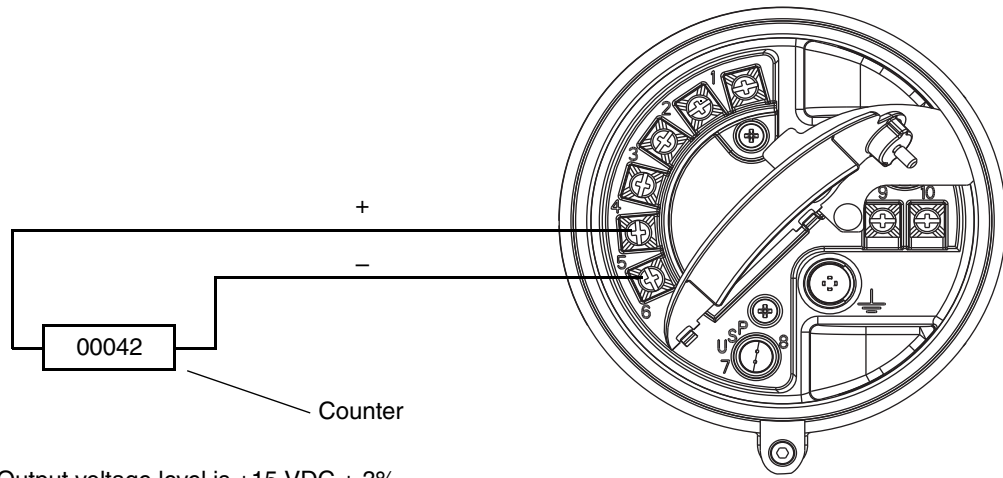

Output voltage level is +15 VDC \pm 3%

Note: See Figure 6-14 for output voltage versus load resistance.

Figure 6-8 Frequency output – Terminals 5 & 6 (Channel C) – External power

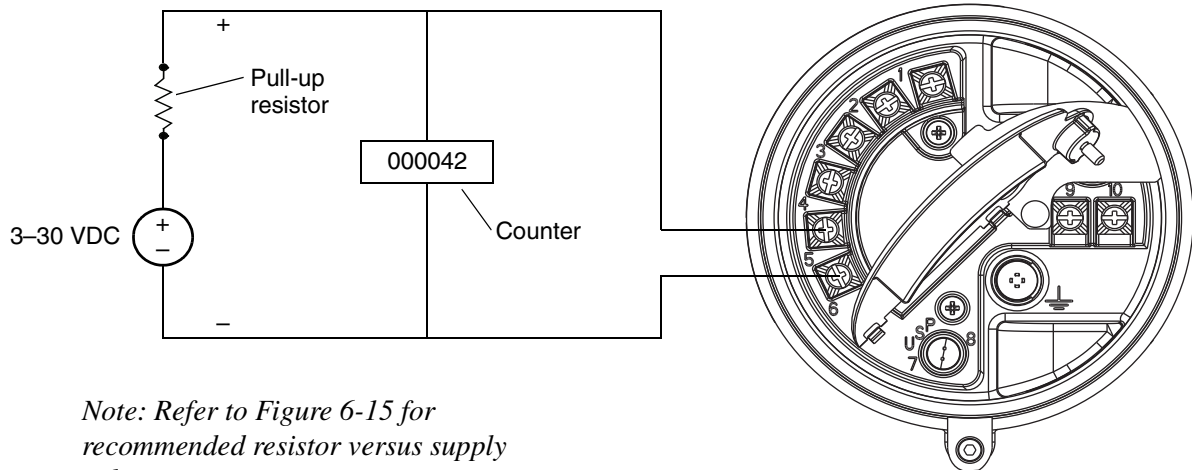

Note: Refer to Figure 6-15 for recommended resistor versus supply voltage.

⚠ CAUTION

Excessive current will damage the transmitter.

Do not exceed 30 VDC input. Terminal current must be less than 500 mA.

Output Wiring – Model 2700 Configurable I/O Transmitters

6.5 Discrete output wiring

Discrete output (DO) wiring depends on whether you are wiring terminals 3 and 4 (Channel B) or terminals 5 and 6 (Channel C), and also on whether you have configured the terminals for internal or external power. The following diagrams are examples of proper wiring for these configurations:

- Channel B, internal power – Figure 6-9
- Channel B, external power – Figure 6-10
- Channel C, internal power – Figure 6-11
- Channel C, external power – Figure 6-12

Figure 6-9 Discrete output 1 – Terminals 3 & 4 (Channel B) – Internal power

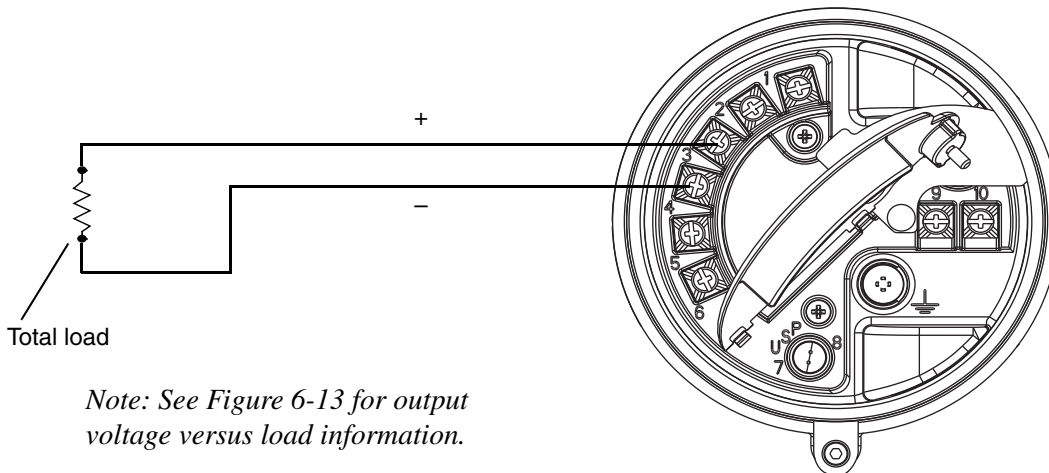
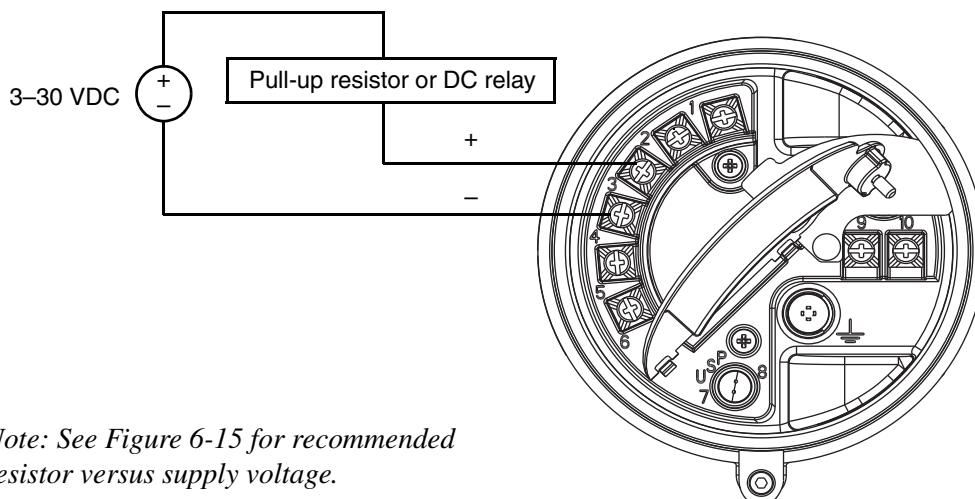

Figure 6-10 Discrete output 1 – Terminals 3 & 4 (Channel B) – External power



⚠ CAUTION

Excessive current will damage the transmitter.

Do not exceed 30 VDC input. Terminal current must be less than 500 mA.

Output Wiring – Model 2700 Configurable I/O Transmitters

Figure 6-11 Discrete output 2 – Terminals 5 & 6 (Channel C) – Internal power

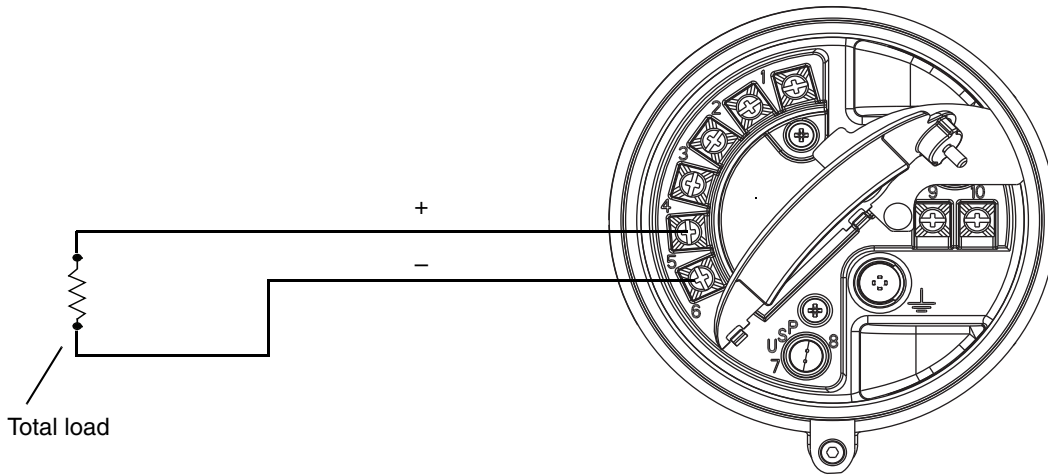

Note: See Figure 6-14 for output voltage versus load.

Figure 6-12 Discrete output 2 – Terminals 5 & 6 (Channel C) – External power

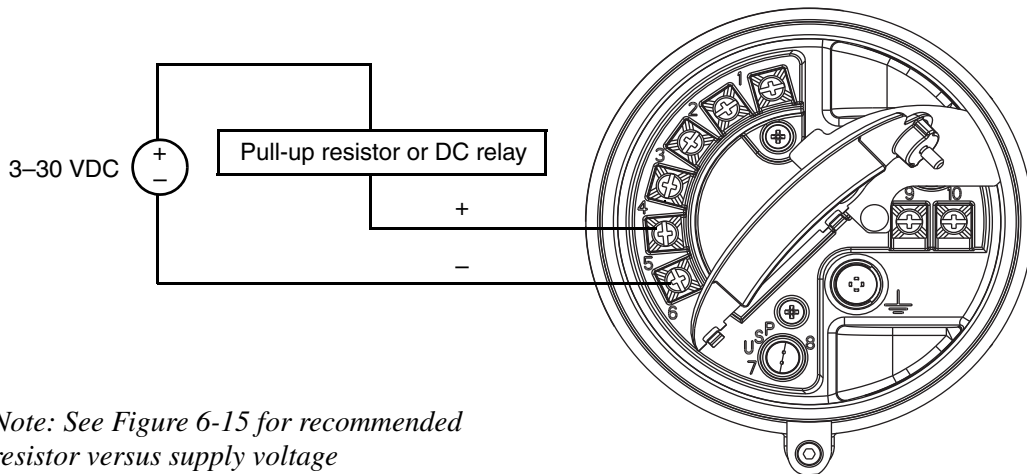

Note: See Figure 6-15 for recommended resistor versus supply voltage

⚠ CAUTION

Excessive current will damage the transmitter.

Do not exceed 30 VDC input. Terminal current must be less than 500 mA.

Figure 6-13 Output voltage vs. load resistance – Terminals 3 & 4 (Channel B) – Internal power

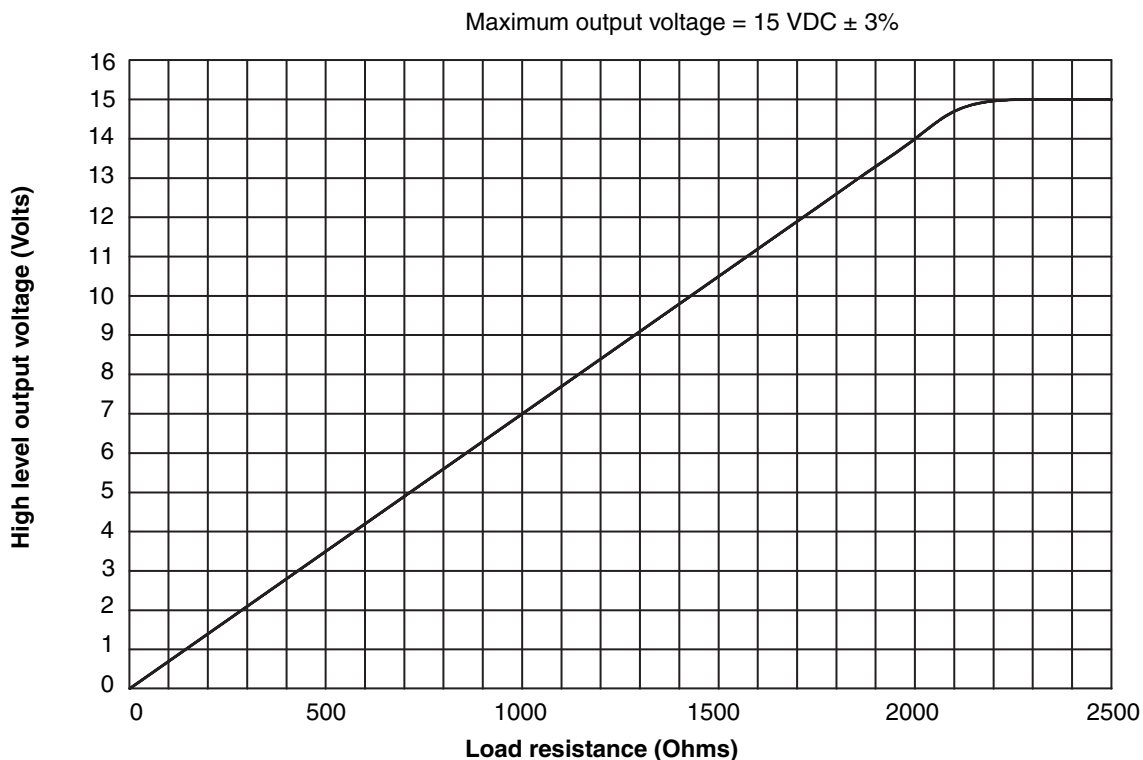

Figure 6-14 Output voltage vs. load resistance – Terminals 5 & 6 (Channel C) – Internal power

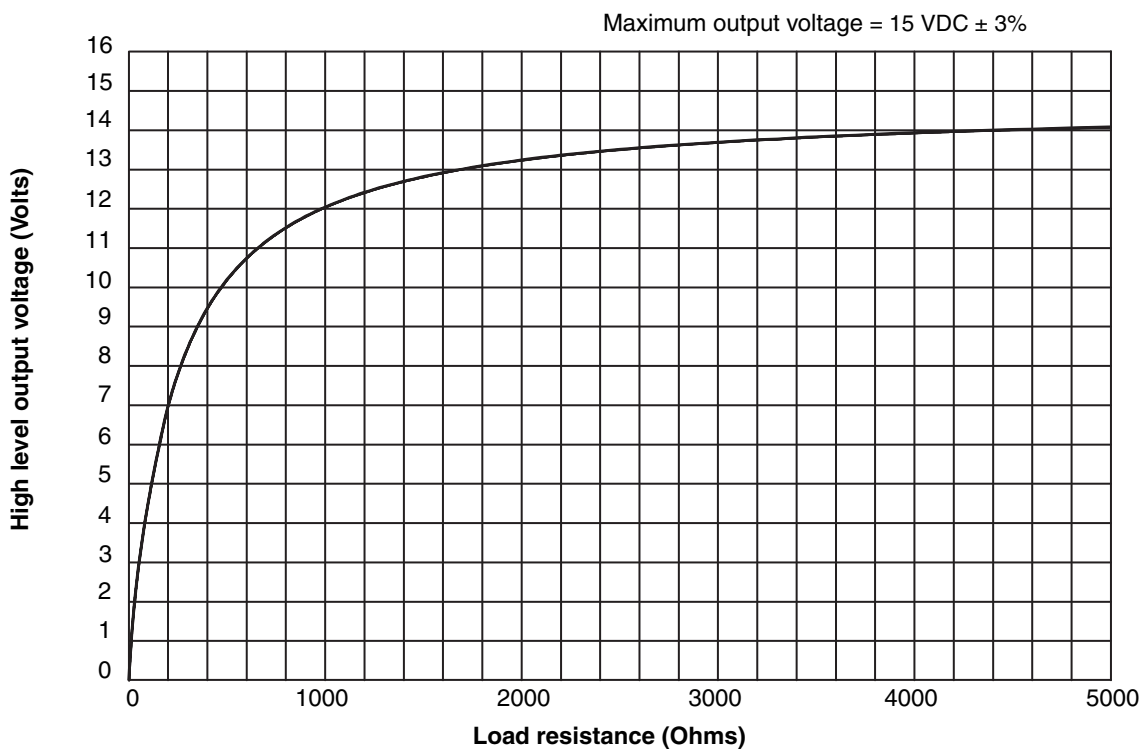
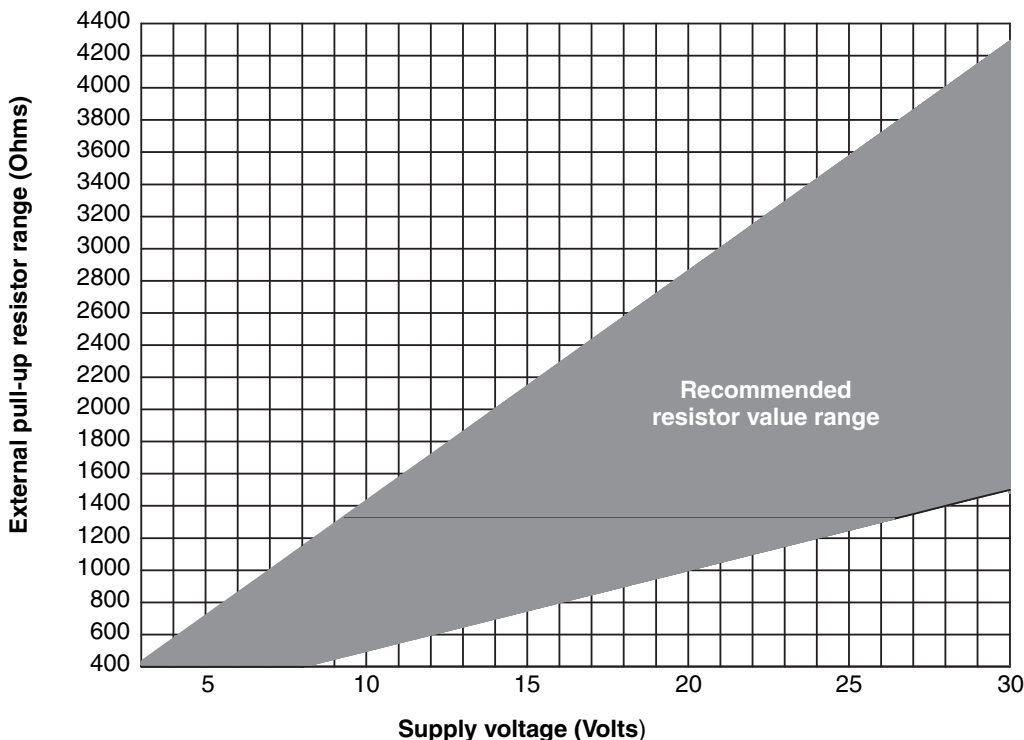

Figure 6-15 Recommended pull-up resistor versus supply voltage – External power



Note: When using a discrete output to drive a relay, choose external pull-up to limit current to less than 500 mA.

6.6 Discrete input wiring

Discrete input wiring depends on whether you have configured terminals 5 and 6 (Channel C) for internal or external power. The following diagrams are examples of proper wiring for these configurations.

If external power is configured, power may be supplied by a PLC or other device, or by direct DC input. See Table 6-2 for input voltage ranges.

Table 6-2 Input voltage ranges for external power

VDC	Range
3–30	High level
0–0.8	Low level
0.8–3	Undefined

Figure 6-16 Discrete input – Terminals 5 & 6 (Channel C) – Internal power

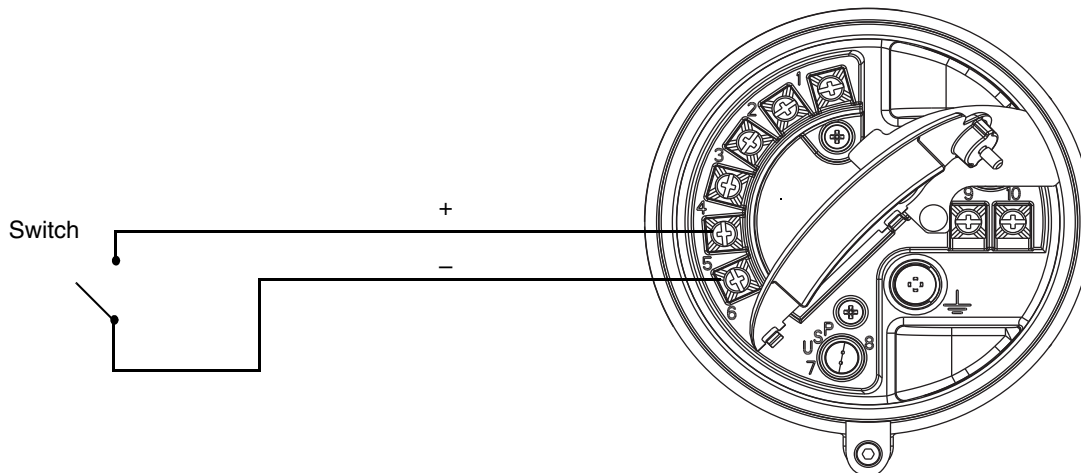
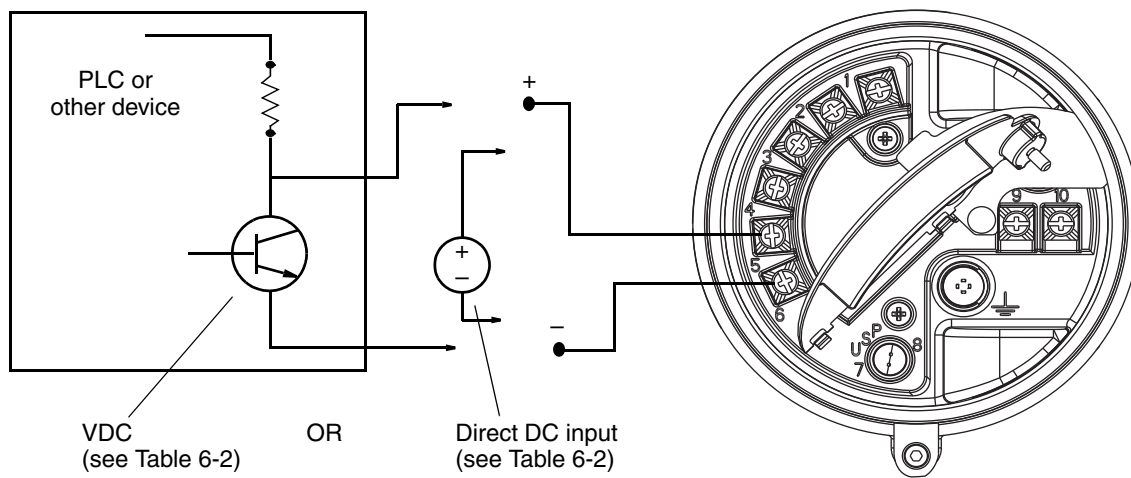

Figure 6-17 Discrete input – Terminals 5 & 6 (Channel C) – External power



Chapter 7

Output Wiring – Model 2700 FOUNDATION fieldbus and PROFIBUS-PA Transmitters

7.1 Overview

This chapter explains how to wire outputs for Model 2700 transmitters with the FOUNDATION fieldbus and PROFIBUS-PA output boards (output option code E, N, or G).

Note: If you don't know what outputs option board is in your transmitter, see Section 1.4.

It is the user's responsibility to verify that the specific installation meets the local and national safety requirements and electrical codes.

7.2 FOUNDATION fieldbus wiring

Wire the transmitter to the fieldbus segment according to the diagram in Figure 7-1. Follow all local safety regulations. The transmitter is either FISCO or FNICO approved (see Section A.1.1). For FISCO-approved transmitters, a barrier is required. Refer to the FOUNDATION fieldbus wiring specification.

Figure 7-1 Connecting the fieldbus communication wires

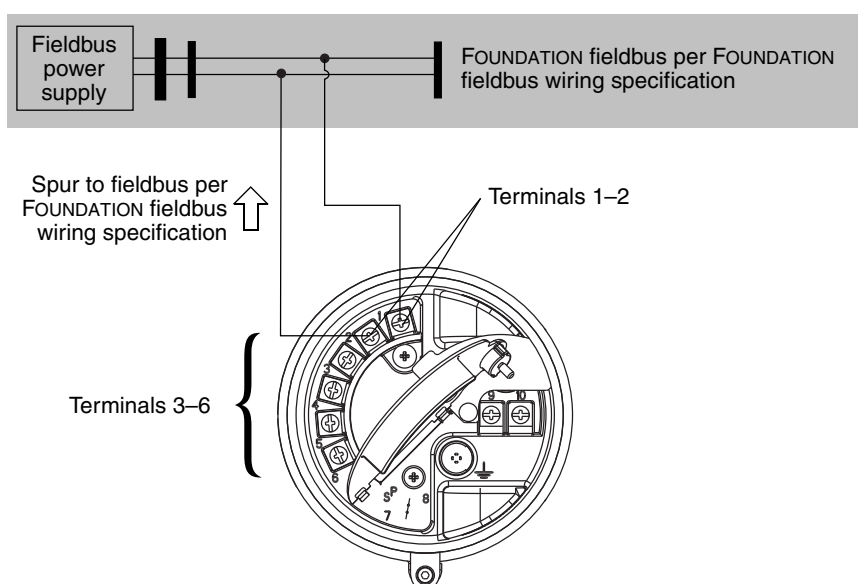

Note: Terminals 3 through 6 are not used.

Note: The fieldbus communication terminals (1 and 2) are polarity insensitive.

7.3 PROFIBUS-PA wiring

Wire the transmitter to the PROFIBUS-PA segment according to the diagram in Figure 7-2. Follow all local safety regulations. The transmitter is FISCO approved — see Section A.1.1.

Figure 7-2 Connecting the PROFIBUS-PA communication wires

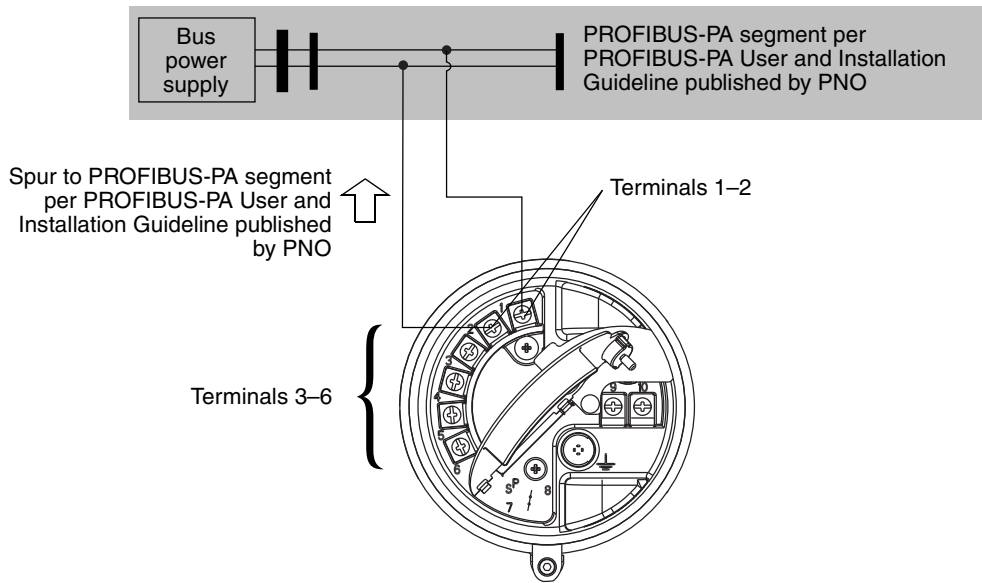

Note: Terminals 3 through 6 are not used.

Note: The PROFIBUS communication terminals (1 and 2) are polarity insensitive.

Note: If you want intrinsically safe wiring, see the PROFIBUS-PA User and Installation Guide published by PNO.

Appendix A

Specifications

A.1 Functional specifications

The Model 1700 or 2700 transmitter's functional specifications include:

- Electrical connections
- Input/output signals
- Digital communication
- Power supply
- Environmental requirements
- Ambient temperature effect
- EMC compliance

A.1.1 Electrical connections

Output connections

The transmitter has two (Model 1700) or three (Model 2700) pairs of wiring terminals for transmitter outputs.

- The Model 1700/2700 with analog outputs option board has one pair of wiring terminals for digital communications (Modbus or HART protocol on RS-485)
- On the Model 2700 with FOUNDATION fieldbus or PROFIBUS-PA, terminals 3–6 are not used.

Screw terminals accept one or two solid conductors, 14 to 12 AWG (2,5 to 4,0 mm²), or one or two stranded conductors, 22 to 14 AWG (0,34 to 2,5 mm²).

Power connection

The transmitter has two pairs of wiring terminals for the power connection:

- One pair of wiring terminals accepts AC or DC power
- One internal ground lug for power-supply ground wiring

Screw terminals accept one or two solid conductors, 14 to 12 AWG (2,5 to 4,0 mm²), or one or two stranded conductors, 22 to 14 AWG (0,34 to 2,5 mm²).

Service port connection

The transmitter has two clips for temporary connection to the service port.

Specifications

Core processor connection

The transmitter has two pairs of wiring terminals for the 4-wire connection to the core processor:

- One pair is used for the RS-485 connection
- One pair is used to supply power to the core processor

Plug connectors accept stranded or solid conductors, 24 to 12 AWG (0,2 to 2,5 mm²).

FISCO and FNICO approval

Model 2700 transmitters with FOUNDATION fieldbus and PROFIBUS-PA are either FISCO or FNICO approved depending on their output code:

- Transmitters with output code E (intrinsically safe FOUNDATION fieldbus) or output code G (PROFIBUS-PA) are FISCO approved with the following entity parameters:
 - $U_i = 30 \text{ V}$
 - $I_i = 380 \text{ mA}$
 - $P_i = 5.32 \text{ W}$
 - $C_i = 0.0002 \text{ }\mu\text{F}$
 - $L_i = 0.0 \text{ mH}$
- Transmitters with output code N (non-incendive FOUNDATION fieldbus) are FNICO approved

A.1.2 Input/output signals

Input signal from sensor

- 4-wire remote: one intrinsically safe 4-wire mating connector
- 9-wire remote: two intrinsically safe terminal blocks with 3 sockets and one intrinsically safe terminal block with 4 sockets (only 3 sockets are used)
- Remote core processor with remote transmitter:
 - Core processor: two intrinsically safe terminal blocks with 3 sockets and one intrinsically safe terminal block with 4 sockets (only 3 sockets are used)
 - Transmitter: one intrinsically safe 4-wire mating connector

Model 1700/2700 transmitters with non-intrinsically safe analog outputs option board (output option code A)

One 4–20 mA output

- Not intrinsically safe
- Internally powered (active)
- Isolated to $\pm 50 \text{ VDC}$ from all other outputs and earth ground
- Maximum load limit: 820 Ohms
- Model 1700 can report mass flow or volume flow; Model 2700 can report mass flow, volume flow, density, temperature, or drive gain; transmitters with the petroleum measurement application (API) or enhanced density application can also report standard volume flow and density at reference temperature
- Linear with process from 3.8 to 20.5 mA, per NAMUR NE43 (June 1994)

Specifications

One frequency/pulse output (Model 1700 transmitters) or frequency/pulse/discrete output (Model 2700 transmitters):

- Not intrinsically safe
- Internally powered (active)
- Maximum current: 100 mA
- Output voltage: +24 VDC $\pm 3\%$, with a 2.2 kohm internal pull-up resistor
- Frequency/pulse output (Model 1700/2700):
 - Can be used to indicate either flow rate or total; Model 1700 output reports the same flow variable as the mA output, Model 2700 output is independent from mA output
 - Scalable to 10,000 Hz
 - Linear with flow rate to 12,500 Hz
 - Configurable polarity: active high or active low
- Discrete output (Model 2700 only):
 - Can report event 1, event 2, event 1 or 2, flow direction, flow switch, calibration in progress, or fault
 - Maximum sink capability: 500 mA
 - Configurable polarity: active high or active low

Model 1700/2700 transmitters with intrinsically safe outputs option board (output option code D)

Model 1700 has one 4–20 mA output; Model 2700 has two 4–20 mA outputs:

- Intrinsically safe
- Externally powered (passive)
- Isolated to ± 50 VDC from all other outputs and earth ground
- Maximum input voltage: 30 VDC, 1 watt maximum
- Model 1700 can report mass flow or volume flow; Model 2700 can report mass flow, volume flow, density, temperature, or drive gain; transmitters with the petroleum measurement application (API) or enhanced density application can also report standard volume flow and density at reference temperature
- Linear with process from 3.8 to 20.5 mA, per NAMUR NE43 (June 1994)
- Maximum load limits: see following chart

Specifications

mA Output Load Resistance Value
 $R_{\max} = (V_{\text{supply}} - 12)/0.023^*$
*If communicating with HART a minimum of 250 Ohms
and 17.75 V supply is needed

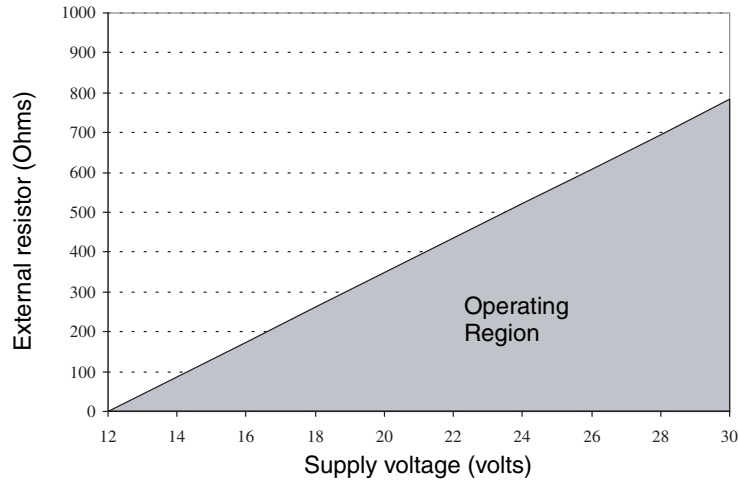

One frequency/pulse output (Model 1700 transmitters) or frequency/pulse/discrete output (Model 2700 transmitters):

- Intrinsically safe
- Externally powered (passive)
- Maximum input voltage: 30 VDC, 0.75 watt maximum
- Frequency/pulse output (Model 1700/2700):
 - Can be used to indicate either flow rate or total; Model 1700 output reports the same flow variable as the mA output, Model 2700 output is independent from mA output
 - Scalable to 10,000 Hz
 - Linear with flow rate to 12,500 Hz
 - Configurable polarity: active high or active low
 - Maximum load limit: see following chart

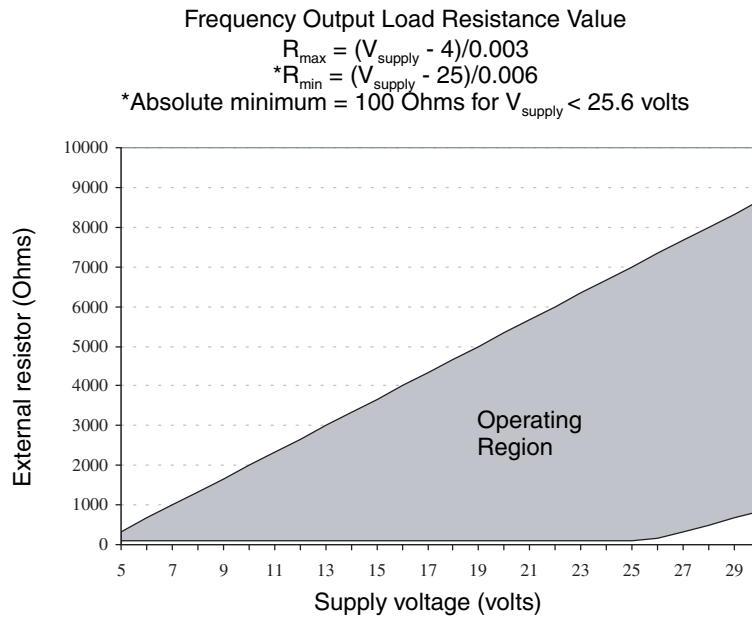

- Discrete output (Model 2700 only):
 - Can report event 1, event 2, event 1 or 2, flow direction, flow switch, calibration in progress, or fault
 - Configurable polarity: active high or active low

Model 2700 transmitters with non-intrinsically safe configurable input/outputs option board (output option code B or C)

One or two 4–20 mA outputs:

- Channel A is always an mA output; Channel B is configurable as an mA output
- Not intrinsically safe
- Internally powered (active)
- Isolated to ± 50 VDC from all other outputs and earth ground
- Maximum load limit:
 - Channel A (mA1): 820 Ohms
 - Channel B (mA2): 420 Ohms
- Can report mass flow, volume flow, density, temperature, or drive gain; transmitters with the petroleum measurement application (API) or enhanced density application can also report standard volume flow and density at reference temperature
- Linear with process from 3.8 to 20.5 mA, per NAMUR NE43 (June 1994)

Specifications

One or two frequency/pulse outputs:

- Channels B and C are configurable as frequency/pulse outputs
- If both are configured for frequency/pulse:
 - The channels function as a dual-pulse output which reports a single process variable. Channels are electrically isolated but not independent
 - Output on channel C can be phase-shifted 0, 90, or 180 degrees from the output on channel B, or the dual-pulse output can be set to quadrature mode
- Not intrinsically safe
- Configurable for internal or external power (active or passive):
 - If internally powered, output voltage is 15 VDC \pm 3%, internal 2.2 kohm pull-up
 - If externally powered, output voltage is 3–30 VDC maximum, sinking up to 500 mA at 30 VDC maximum
- Scalable to 10,000 Hz
- Can report mass flow rate or volume flow rate, which can be used to indicate flow rate or total flow
- Linear with flow rate to 12,500 Hz
- Configurable polarity: active high or active low

One or two discrete outputs:

- Channels B and C are configurable as discrete outputs
- Can report event 1, event 2, event 1 & 2, flow direction, flow switch, calibration in progress, or fault
- Maximum sink capability: 500 mA
- Configurable for internal or external power (active or passive):
 - If internally powered, output voltage is 15 VDC \pm 3%, internal 2.2 kohm pull-up
 - If externally powered, output voltage is 3–30 VDC maximum, sinking up to 500 mA at 30 VDC maximum
- Configurable polarity: active high or active low

One discrete input:

- Channel C is configurable as a discrete input
- Not intrinsically safe
- Configurable for internal or external power:
 - Internal power: 15 VDC, 7 mA maximum source current
 - External power: 3–30 VDC maximum
- Can be used to start flowmeter zeroing procedure, reset mass total, reset volume total, reset corrected volume total, or reset all totals

Model 2700 transmitters with intrinsically safe FOUNDATION fieldbus outputs option board (output option code E)

One FOUNDATION fieldbus H1 output:

- FOUNDATION fieldbus wiring is intrinsically safe with an intrinsically safe power supply
- Manchester-encoded digital signal conforms to IEC 1158-2

Model 2700 transmitters with non-incendive FOUNDATION fieldbus outputs option board (output option code N)

One FOUNDATION fieldbus H1 output:

- FOUNDATION fieldbus wiring is non-incendive
- Manchester-encoded digital signal conforms to IEC 1158-2

Model 2700 transmitters with PROFIBUS-PA outputs option board (output option code G)

One PROFIBUS-PA output:

- PROFIBUS-PA wiring is intrinsically safe with an intrinsically safe PROFIBUS-PA network power supply
- Manchester-encoded digital signal conforms to IEC 1158-2

A.1.3 Digital communication

Model 1700/2700 transmitters support the following digital communications:

Service port

- One service port can be used for temporary connection only
- Address 111
- Uses RS-485 Modbus RTU signal, 38.4 kilobaud, one stop bit, no parity

HART/Bell202

A HART/Bell202 signal can be superimposed on the primary mA output and used for interface with a host system:

- Frequency: 1.2 and 2.2 kHz
- Amplitude: 0.8 mA peak-to-peak
- 1200 baud
- Requires 250 to 600 Ohms load resistance

HART/RS485 or Modbus/RS485 (transmitters with analog outputs option board only)

One pair of terminals provides RS-485 communications:

- Can be used for direct connection to a HART or Modbus host system
- Accepts baud rates between 1200 baud and 38.4 kilobaud

FOUNDATION fieldbus or PROFIBUS-PA transmitters

One pair of terminals provides FOUNDATION fieldbus or PROFIBUS-PA communications:

- Resource, transducer, and function blocks per FOUNDATION or PROFIBUS specification

Specifications

A.1.4 Power supply

The Model 1700/2700 transmitter's power supply:

- Has a self-switching AC/DC input
- Complies with low voltage directive 2006/95/EC per EN 61010-1 (IEC 61010-1) with amendment 2
- Meets Installation (Overvoltage) Category II, Pollution Degree 2 requirements
- Has an IEC 127–1.25 slowblow fuse

AC power requirements

85 to 265 VAC, 50/60 Hz, 6 watts typical, 11 watts maximum

DC power requirements

- 18 to 100 VDC, 6 watts typical, 11 watts maximum
- At startup, transmitter power source must provide a minimum of 1.5 amps of short-term current at a minimum of 18 volts at the transmitter power input terminals
- Minimum 22 VDC with 1000 feet (300 meters) of 18 AWG (0,8 mm²) power supply cable

A.1.5 Environmental requirements

Ambient temperature limits

- Operation: –40 to +140 °F (–40 to +60 °C)
- Storage: –40 to +140 °F (–40 to +60 °C)

Display responsiveness decreases, and display may become difficult to read, below –4 °F (–20 °C). Above 131 °F (55 °C), some darkening of display may occur.

If possible, install the transmitter in a location that will prevent direct exposure to sunlight.

Different ambient temperature requirements may apply when installing the transmitter in a hazardous area. Refer to the approval documentation shipped with the transmitter or available on the Micro Motion web site.

Humidity limits

Relative humidity between 5 and 95%, non-condensing at 140 °F (60 °C)

Vibration limits

The transmitter meets IEC 68.2.6, endurance sweep, 5 to 2000 Hz, 50 sweep cycles at 1.0 g

A.1.6 Ambient temperature effect

On analog outputs $\pm 0.005\%$ of span per °C

A.1.7 EMC compliance

The transmitter complies with the following EMI effects standards:

- NAMUR NE21 (May 1999) with the exception of Voltage Dip when powered by 24 VDC
- Complies with EMC directive 2004/108/EC per EN 61326 Industrial

Specifications

A.2 Hazardous area classifications

The transmitter may have a tag listing hazardous area classifications, which indicate suitability for installation in the hazardous areas described in this section.

A.2.1 UL and CSA

Ambient temperature is limited to -40 to $+131$ °F (-40 to $+55$ °C) for UL compliance.

Ambient temperature is limited to -40 to $+140$ °F (-40 to $+60$ °C) for CSA compliance.

Transmitter

Class I, Division 1, Groups C and D. Class II, Division 1, Groups E, F, and G explosion proof (when installed with approved conduit seals). Otherwise, Class I, Division 2, Groups A, B, C, and D.

Outputs

Provides nonincendive sensor outputs for use in Class I, Division 2, Groups A, B, C, and D; or intrinsically safe sensor outputs for use in Class I, Division 1, Groups C and D or Class II, Division 1, Groups E, F, and G.

A.2.2 ATEX and IECEx

Ambient temperature is limited to below 131 °F (55 °C) for ATEX and IECEx compliance. Table A-1 lists the classification codes for each transmitter output option.

Table A-1 ATEX and IECEx classifications

Output option	Classification	ATEX	IECEx
Analog, non-incendive FOUNDATION fieldbus, and configurable I/O (output options A, N, B, and C)	Flameproof when installed with approved cable glands:		
	• With display	EEx d [ib] IIB+H2 T5	Ex d [ib] IIB+H2 T5
	• Without display	EEx d [ib] IIC T5	Ex d [ib] IIC T5
	Increased safety when installed with approved cable glands:		
	• With display	EEx de [ib] IIB+H2 T5	Ex de [ib] IIB+H2 T5
	• Without display	EEx de [ib] IIC T5	Ex de [ib] IIC T5
Intrinsically safe analog, intrinsically safe FOUNDATION fieldbus, and PROFIBUS-PA (output options D, E, and G)	Flameproof when installed with approved cable glands:		
	• With display	EEx d [ia/ib] IIB+H2 T5	Ex d [ia/ib] IIB+H2 T5
	• Without display	EEx d [ia/ib] IIC T5	Ex d [ia/ib] IIC T5
	Increased safety when installed with approved cable glands:		
	• With display	EEx de [ia/ib] IIB+H2 T5	Ex de [ia/ib] IIB+H2 T5
	• Without display	EEx de [ia/ib] IIC T5	Ex de [ia/ib] IIC T5

Specifications

A.3 Performance specifications

For performance specifications, refer to the sensor specifications.

A.4 Physical specifications

The physical specifications of the transmitter include:

- Housing
- Mounting
- Interface/display (optional)
- Weight
- Dimensions

A.4.1 Housing

NEMA 4X (IP67) epoxy painted cast aluminum housing.

Terminal compartment contains output terminals, power terminals and service-port terminals. The output terminals are physically separated from the power- and service-port terminals.

- The electronics compartment contains all electronics and the standard display.
- The sensor compartment contains the wiring terminals for connection to the core processor on the sensor.

Screw-terminal on housing for chassis ground.

Cable gland entrances are either 1/2"–14 NPT or M20 × 1.5 female conduit ports.

A.4.2 Mounting

Model 1700/2700 transmitters are available integrally mounted to some Micro Motion sensors, or in two remote-mount configurations.

- Remote-mount transmitters include a mounting bracket, and require 4-wire or 9-wire signal cables between the sensor and the transmitter. Maximum distance from other flowmeter components depends on the installation type and cable type, as described in Table A-2.
- The transmitter can be rotated on the sensor or the mounting bracket, up to 360° in 90° increments.

Table A-2 Maximum cable lengths

Cable type	Wire gauge	Maximum length
Micro Motion 9-wire	Not applicable	60 feet (20 meters)
Micro Motion 4-wire	Not applicable	1000 feet (300 meters)
User-supplied 4-wire		
• Power wires (VDC)	22 AWG (0,35 mm ²)	300 feet (90 meters)
	20 AWG (0,5 mm ²)	500 feet (150 meters)
	18 AWG (0,8 mm ²)	1000 feet (300 meters)
• Signal wires (RS-485)	22 AWG (0,35 mm ²) or larger	1000 feet (300 meters)

A.4.3 Interface/display

The transmitter may be ordered with or without a display. The characteristics of the display are as follows:

- Segmented 2-line display with LCD screen with optical controls and flowmeter-status LED is suitable for hazardous area installation
 - LCD line 1 lists the process variable, line 2 lists engineering unit of measure through a non-glare tempered glass lens
 - Display controls feature optical switches that are operated through the glass with a red LED indicator to show that the “button” has been pressed
- To facilitate various mounting orientations, the display can rotate 360° on the transmitter in 90° increments

A.4.4 Weight

For the weight of a transmitter mounted integrally with a sensor, refer to the sensor specifications.

The 4-wire remote transmitter weighs:

- With display: 8 lb (3,6 kg)
- Without display: 7 lb (3,2 kg)

The 9-wire remote transmitter/core processor assembly weighs:

- With display: 14 lb (6,3 kg)
- Without display: 13 lb (5,9 kg)

A.4.5 Dimensions

Figures A-1 through A-5 show the dimensions of the Model 1700 or 2700 transmitter with and without a display, the transmitter/core processor assembly with and without a display, and the stand-alone core processor. For dimensions of integrally mounted transmitters and sensors, refer to the product data sheet for your sensor.

Specifications

Figure A-1 Dimensions – Model 1700/2700 transmitter with display

Dimensions in inches
(mm)

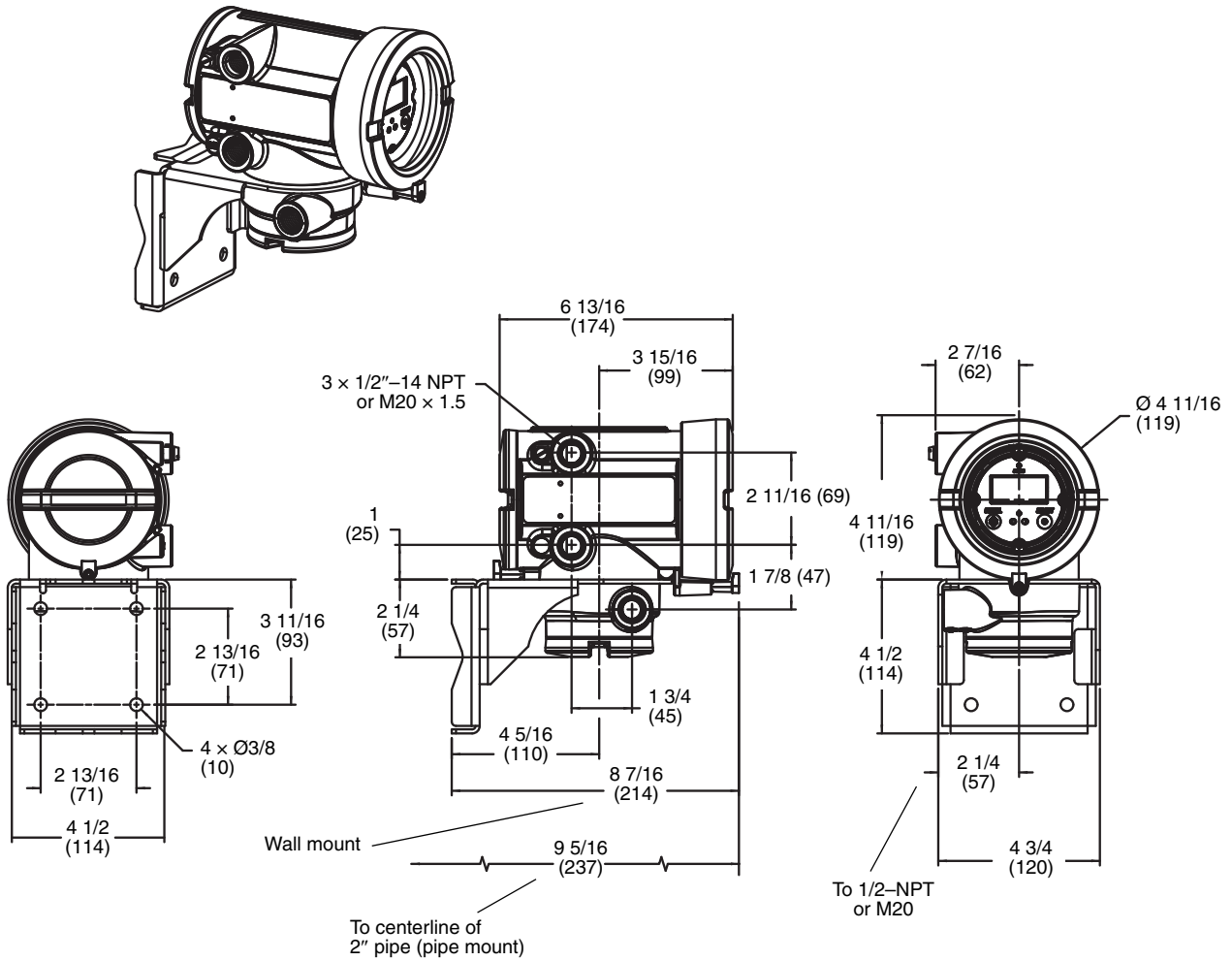

Note: These dimensions apply to the transmitter in 4-wire remote installations or remote core processor with remote transmitter installations. See Figure 2-1.

Specifications

Figure A-2 Dimensions – Model 1700/2700 transmitter without display

Dimensions in inches (mm)

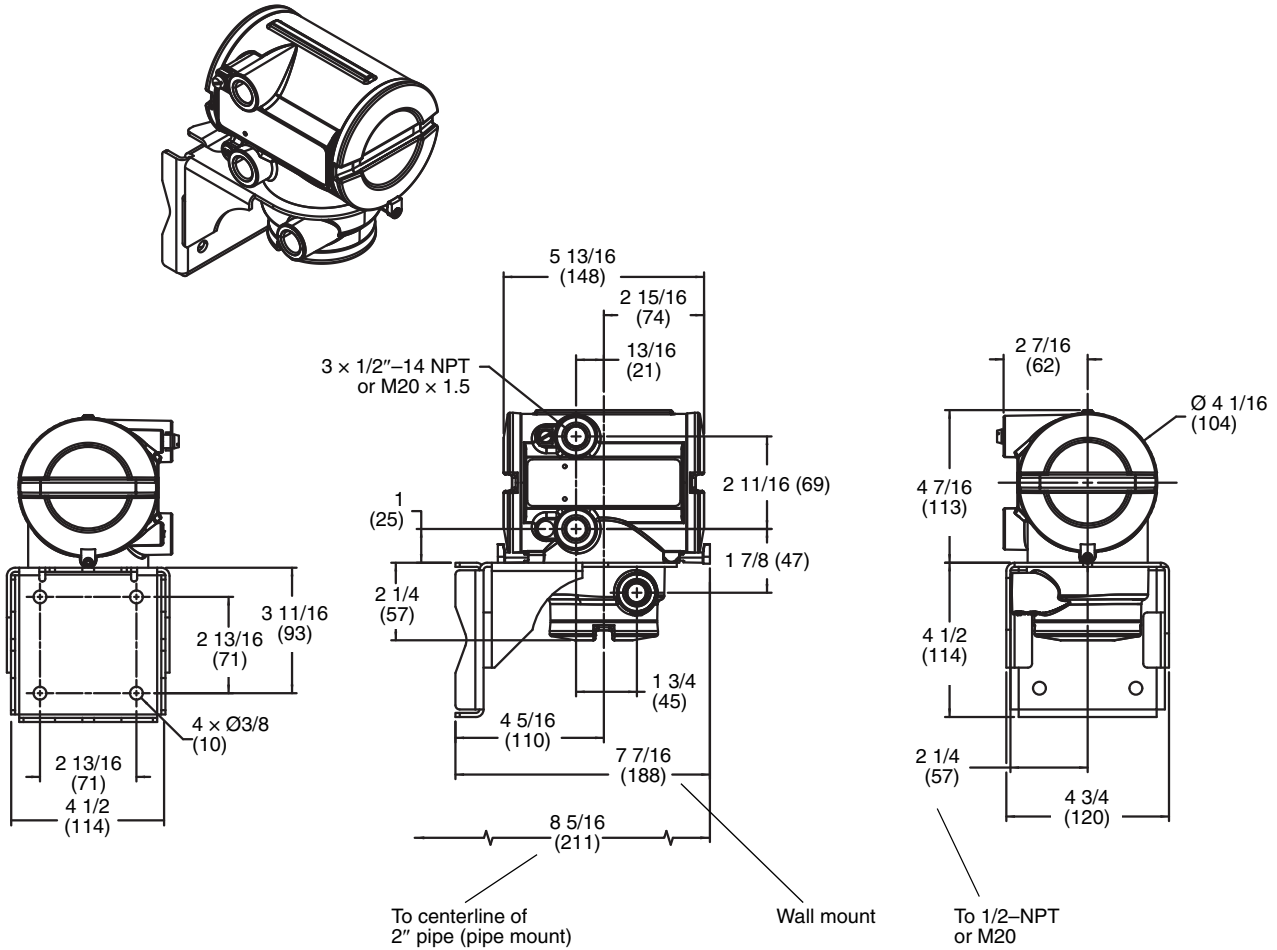

Note: These dimensions apply to the transmitter in 4-wire remote installations or remote core processor with remote transmitter installations. See Figure 2-1.

Specifications

Figure A-3 Dimensions – Model 1700/2700 transmitter/core processor assembly with display

Dimensions in inches
(mm)

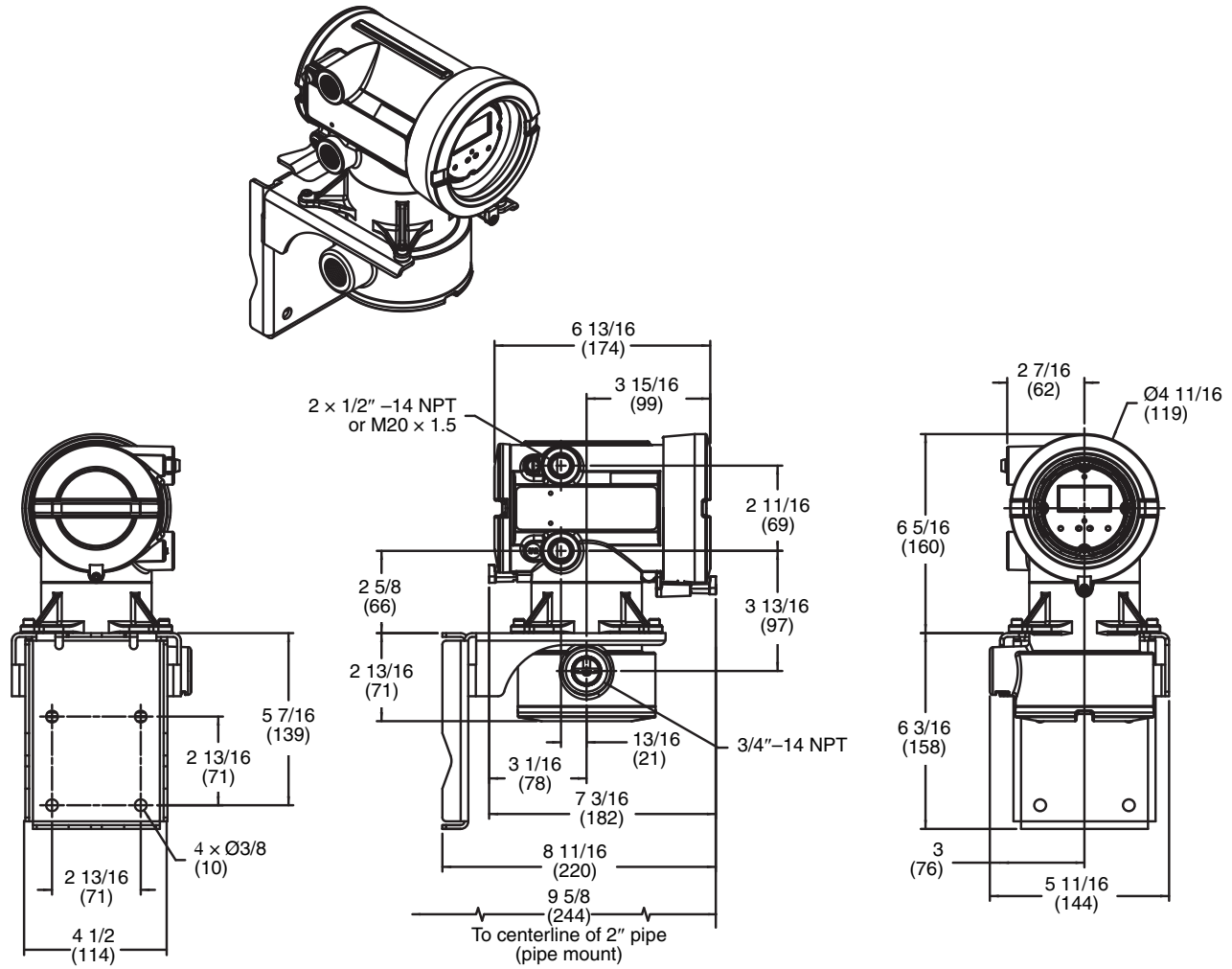

Note: These dimensions apply only to the transmitter/core processor assembly in 9-wire remote installations. See Figure 2-1.

Specifications

Figure A-4 Dimensions – Model 1700/2700 transmitter/core processor assembly without display

Dimensions in *inches*
(*mm*)

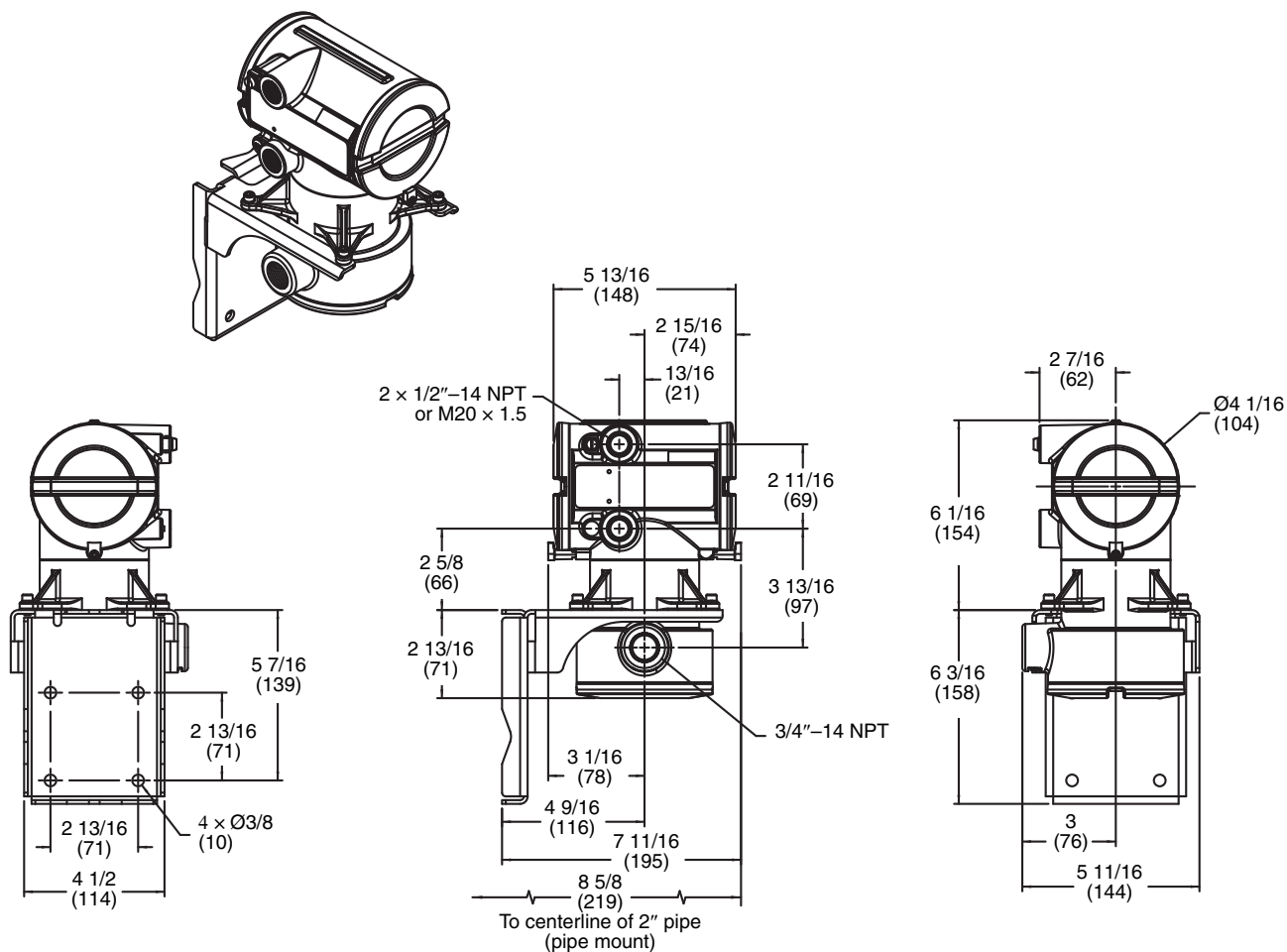

Note: These dimensions apply only to the transmitter/core processor assembly in 9-wire remote installations. See Figure 2-1.

Specifications

Figure A-5 Dimensions – Remote core processor

Dimensions in inches
(mm)

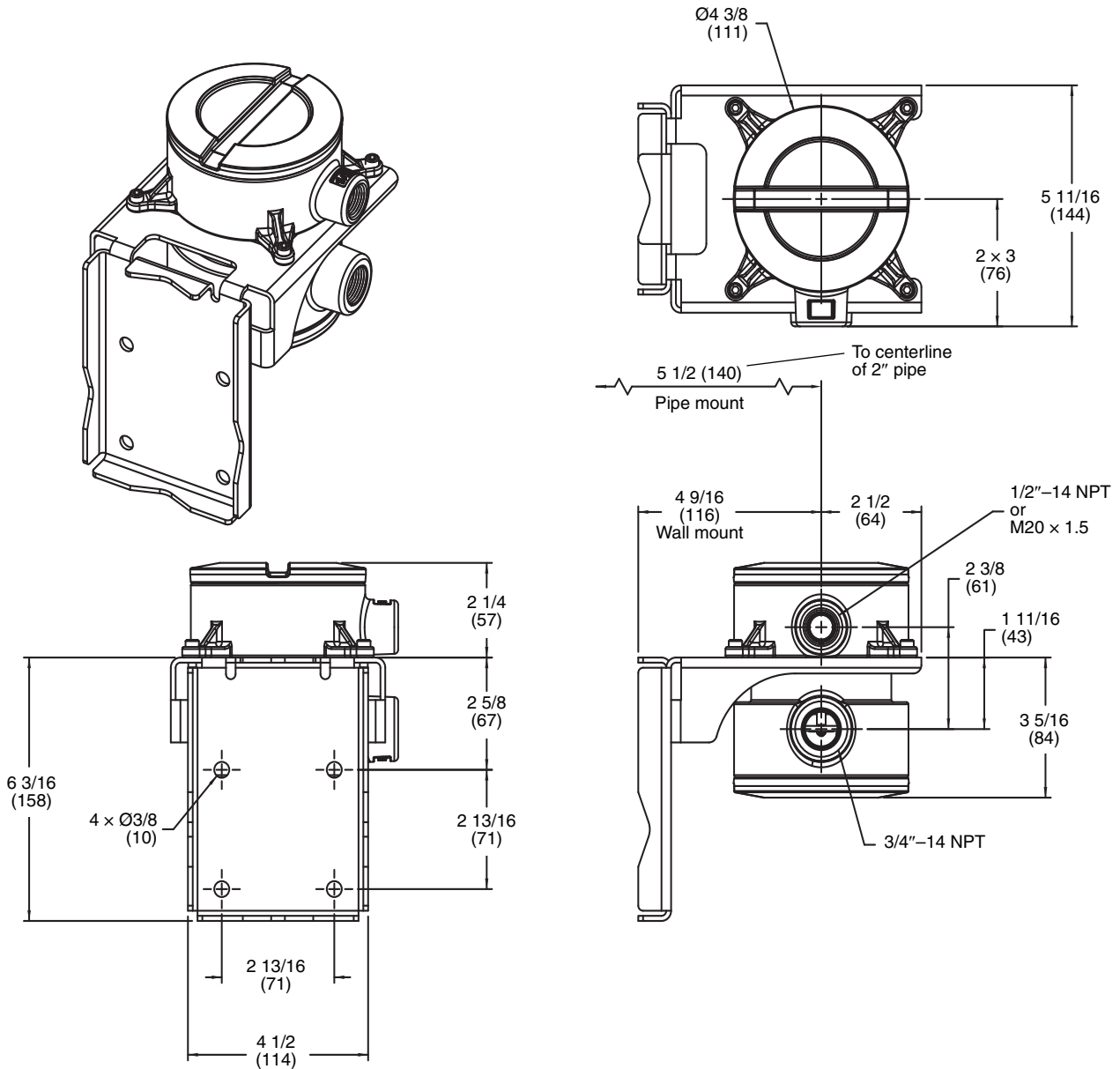

Note: These dimensions apply only to the core processor component in remote core processor with remote transmitter installations. See Figure 2-1.

Index

A

- Accessibility 9
- Ambient temperature effect 62
- ATEX
 - installation requirements 7
 - specifications 63

C

- Cable
 - maximum cable length 9
 - types 19
 - 4-wire cable 20
 - 9-wire cable 20
- Channel configuration 41
- Clearance 9
- Core processor 2
 - components in remote core processor 14
 - mounting the remote 13
- CSA
 - installation requirements 7
 - specifications 63

D

- Digital communications
 - specifications 61
- Dimensions 65
- Display
 - components 18
 - rotating 16

E

- Electrical connections
 - specifications 55
- EMC compliance 62
- Environmental requirements 7
 - specifications 62

F

- FISCO 56
- Flowmeter components 2
- FNICO 56
- FOUNDATION fieldbus wiring 53
- Four-wire remote wiring 20

G

- Grounding requirements 15

H

- Hazardous area classifications 7
 - specifications 63
- Housing specifications 64
- Humidity limits 7

I

- IECE_x
 - installation requirements 7
 - specifications 63
- Input/output signals
 - specifications 56
- Installation
 - accessibility 9
 - cable types 19
 - channel configuration 41
 - clearance 9
 - environmental requirements 7
 - grounding 15
 - hazardous areas 7
 - humidity limits 7
 - maximum cable length 9
 - mounting the remote core processor 13
 - mounting the transmitter 9
 - 4-wire remote installations 11
 - 9-wire remote installations 12
 - integral installations 10
 - remote core processor with remote transmitter installations 11
 - power source requirements 7
 - power supply 16
 - rotating the display 16
 - temperature limits 7
 - transmitter specifications 55
 - type 2
 - vibration limits 7
 - wiring for 4-wire remote installations 20
 - wiring for 9-wire remote 22
 - wiring instructions for remote core processor with remote transmitter installations 23
 - wiring outputs
 - Model 1700/2700 AN transmitters 29
 - Model 1700/2700 IS transmitters 33
 - Model 2700 CIO transmitters 41
 - wiring transmitter to sensor 19

Index

Interface/display
specifications 65

J

Junction box 2

L

Location, determining appropriate 7

M

Mounting

- maintaining accessibility 9
- remote core processor 13
- specifications 64
- transmitter 9
 - 4-wire remote installations 11
 - 9-wire remote installations 12
 - integral installations 10
 - remote core processor with remote transmitter installations 11

N

Nine-wire remote wiring 22

O

Output wiring

- Model 1700/2700 AN transmitters 29
 - analog outputs 30
 - HART multidrop 32
 - HART/analog single-loop 31
 - output terminals and output types 29
- Model 1700/2700 IS transmitters 33
 - hazardous area 37
 - frequency/discrete output 39
 - mA outputs 39
 - safety parameters 37
 - output terminals and output types 33
 - safe area 34
 - frequency/discrete output 36
 - HART multidrop 36
 - HART/analog single-loop 35
 - mA outputs 34
- Model 2700 CIO transmitters 41
 - discrete input 50
 - discrete output 47
 - frequency output 44
 - HART multidrop 44
 - HART/analog single-loop 43
 - mA output 42
 - output terminals and output types 41
- Model 2700 FF transmitters 53
- Model 2700 PA transmitters 53

P

Performance specifications 64
Physical specifications 64
Power source requirements 7
Power supply

- installation 16
- specifications 62

PROFIBUS-PA wiring 54

R

Remote core processor with remote transmitter

- wiring instructions 23

Rotating the display 16

S

Safety messages 1
Safety parameters

- hazardous area wiring for Model 1700/2700 IS transmitters 37

Sensor 2
Specifications 55

- ambient temperature effect 62
- digital communications 61
- dimensions 65
- electrical connections 55
- EMC compliance 62
- environmental requirements 62
- FISCO 56
- functional 55
- hazardous area classifications 63
- housing 64
- input/output signals 56
- interface/display 65
- mounting 64
- performance 64
- physical 64
- power supply 62
- weight 65

T

Temperature limits 7
Transmitter 2

- components
 - 4-wire remote installations 12
 - 9-wire remote installations 13
 - remote core processor with remote transmitter installations 12
- installing 1
- mounting 9
 - 4-wire remote installations 11
 - 9-wire remote installations 12
 - integral installations 10

Index

- remote core processor with remote transmitter installations 11
- outputs option board type 2
- type 2

U

UL

- installation requirements 7
- specifications 63

V

- Vibration limits 7

W

- Weight 65

Wiring

- instructions
 - 4-wire remote 20
 - 9-wire remote 22
 - remote core processor with remote transmitter installations 23
- maximum cable length 9
- output
 - See* Output wiring
- transmitter to sensor 19

©2007, Micro Motion, Inc. All rights reserved. P/N 20001700, Rev. C



For the latest Micro Motion product specifications, view the
PRODUCTS section of our web site at www.micromotion.com

Micro Motion Inc. USA
Worldwide Headquarters

7070 Winchester Circle
Boulder, Colorado 80301
T +1 303-527-5200
+1 800-522-6277
F +1 303-530-8459

Micro Motion Europe

Emerson Process Management
Neonstraat 1
6718 WX Ede
The Netherlands
T +31 (0) 318 495 555
F +31 (0) 318 495 556

Micro Motion Asia

Emerson Process Management
1 Pandan Crescent
Singapore 128461
Republic of Singapore
T +65 6777-8211
F +65 6770-8003

Micro Motion United Kingdom

Emerson Process Management Limited
Horsfield Way
Bredbury Industrial Estate
Stockport SK6 2SU U.K.
T +44 0870 240 1978
F +44 0800 966 181

Micro Motion Japan

Emerson Process Management
1-2-5, Higashi Shinagawa
Shinagawa-ku
Tokyo 140-0002 Japan
T +81 3 5769-6803
F +81 3 5769-6844

