

Instruction Manual

748467-A

January 2002

Model MicroCEM

Continuous Emissions Monitor



ROSEMOUNT[®]
Analytical

<http://www.processanalytic.com>

EMERSON[™]
Process Management

ESSENTIAL INSTRUCTIONS

READ THIS PAGE BEFORE PROCEEDING!

Rosemount Analytical designs, manufactures and tests its products to meet many national and international standards. Because these instruments are sophisticated technical products, you **MUST properly install, use, and maintain them** to ensure they continue to operate within their normal specifications. The following instructions **MUST be adhered to** and integrated into your safety program when installing, using, and maintaining Rosemount Analytical products. Failure to follow the proper instructions may cause any one of the following situations to occur: Loss of life; personal injury; property damage; damage to this instrument; and warranty invalidation.

- **Read all instructions** prior to installing, operating, and servicing the product.
- If you do not understand any of the instructions, **contact your Rosemount Analytical representative** for clarification.
- Follow all warnings, cautions, and instructions marked on and supplied with the product.
- Inform and educate your personnel in the proper installation, operation, and maintenance of the product.
- Install your equipment as specified in the Installation Instructions of the appropriate Instruction Manual and per applicable local and national codes. Connect all products to the proper electrical and pressure sources.
- To ensure proper performance, **use qualified personnel** to install, operate, update, program, and maintain the product.
- When replacement parts are required, ensure that qualified people use replacement parts specified by Rosemount. Unauthorized parts and procedures can affect the product's performance, place the safe operation of your process at risk, **and VOID YOUR WARRANTY**. Look-alike substitutions may result in fire, electrical hazards, or improper operation.
- **Ensure that all equipment doors are closed and protective covers are in place, except when maintenance is being performed by qualified persons, to prevent electrical shock and personal injury.**

The information contained in this document is subject to change without notice.

Logos, trademarks and copyrights are property of their respective owners.

Emerson Process Management

Rosemount Analytical Inc. Process Analytic Division

1201 North Main Street
Orrville, Ohio 44667-09012

T (330) 682-9010

F (330) 684-4434

e-mail: gas.csc@EmersonProcess.com

<http://www.processanalytic.com>



TABLE OF CONTENTS

PREFACE	P-1
Definitions	P-1
Intended Use Statement	P-2
Safety Summary	P-2
General Precautions For Handling And Storing High Pressure Gas Cylinders	P-5
Documentation.....	P-6
Compliances	P-6
1-0 DESCRIPTION AND SPECIFICATIONS	1-1
1-1 Overview.....	1-1
1-2 Typical Applications.....	1-1
1-3 Theory Of Operation.....	1-1
a. Chemiluminescence NO _x	1-1
b. Non-Dispersive Infrared (NDIR) CO	1-1
c. Paramagnetic O ₂	1-2
1-4 Detector Methodologies.....	1-2
a. Non-Dispersive Infrared (NDIR).....	1-2
b. Paramagnetic Oxygen Method	1-6
c. Electrochemical Oxygen Method	1-7
1-5 Central Processing Unit.....	1-9
a. Embedded Enhanced Bios	1-9
b. Specifications	1-9
1-6 Analog/Digital I/O Board.....	1-10
a. Automatic Calibration.....	1-10
b. Analog Inputs	1-10
c. Programmable Input Ranges	1-11
d. Enhanced Trigger and Sampling Control Signals.....	1-11
e. Analog Outputs	1-11
f. FIFO and 16-Bit Bus Interface	1-11
g. Specifications.....	1-13
1-7 PCMCIA Adapter	1-14
a. Features	1-14
b. Software	1-14
1-8 Modem.....	1-15
a. Features	1-15
1-9 Flash Drive.....	1-16
a. Specifications	1-16
1-10 Pocket PC.....	1-18
a. Specifications.....	1-18
1-11 Wireless LAN Adapter	1-19
a. Specifications.....	1-19
1-12 500 Watts Power Supply	1-20
a. Features	1-20
1-13 MicroCEM Specifications.....	1-21
a. Analyzer	1-21
b. Probe/Sample Handling	1-22

2-0	INSTALLATION	2-1
2-1	Overview	2-1
	a. Limitations	2-1
	b. Mounting Options	2-1
2-2	Location	2-1
2-3	Gases	2-3
	a. Connection	2-3
	b. Conditioning	2-3
2-4	Electrical Connections	2-6
	a. AC Power	2-8
	b. Circular Connector Assembly Instructions	2-8
	c. Interface Connections	2-11
2-5	Analytical Leak Check	2-14
	a. Flow Indicator Method	2-14
	b. Manometer Method	2-15
3-0	OPERATION	3-1
3-1	Startup Procedure	3-1
3-2	Pocket PC User Interface	3-1
	a. Connecting Pocket PC to MicroCEM	3-1
	b. Main Display	3-3
	c. MicroCEM Menu	3-4
	d. MicroCEM Alarms	3-4
	e. MicroCEM Login	3-6
	f. MicroCEM Login-Current User Indication	3-6
3-3	MicroCEM Settings	3-7
	a. Range	3-7
	b. Auto Calibration	3-8
	c. Auto Calibration Time and Frequency	3-8
	d. Manual Calibration	3-9
	e. Limits	3-10
	f. Calibration Gas	3-10
	g. Maintenance Mode	3-11
3-4	MicroCEM Factory Settings	3-12
	a. PID Control Loop Factory Settings	3-15
3-5	MicroCEM Administration	3-17
	a. User Settings	3-17
	b. Auto Logoff	3-17
3-6	MicroCEM Data Logs	3-18
	a. Maximum Log File Size	3-18
	b. Maximum Number of Log Files	3-18
	c. Log File Name Format	3-18
	d. Measurement Log File Format	3-18
	e. Calibration Log File Format	3-19
	f. Alarm Log File Format	3-20
3-7	View Data Logs	3-21
3-8	Viewing MicroCEM Data with a Web Browser	3-23
	a. Real-Time Page	3-23
	b. Emissions Page	3-24
	c. Download Page	3-26
3-9	Viewing MicroCEM Data with MS Excel	3-27
3-10	Auto Calibration	3-28

Model MicroCEM

4-0	SOFTWARE	4-1
4-1	Overview	4-1
4-2	MicroCEM User Interface Software	4-1
4-3	MicroCEM Web Server Software	4-1
4-4	Software Development Management	4-2
5-0	MAINTENANCE AND SERVICE	5-1
5-1	Overview	5-1
5-2	Converter	5-3
5-3	Ozone Generator	5-4
5-4	Personality Modules	5-4
5-5	Chemiluminescence Detector Assembly	5-5
	a. Reaction Chamber	5-5
	b. Photodiode	5-5
6-0	TROUBLESHOOTING	6-1
6-1	Troubleshooting Leaks	6-1
6-2	Pocket PC Connection Failure	6-1
6-3	Trouble LED	6-1
7-0	REPLACEMENT PARTS	7-1
8-0	RETURN OF MATERIAL	8-1
8-1	Return Of Material	8-1
8-2	Customer Service	8-1
8-3	Training	8-1

LIST OF ILLUSTRATIONS

Figure 1-1. Absorption Bands of Sample Gas and Transmittance of Interference Filters 1-3

Figure 1-2. Opto-Pneumatic Gas Detector..... 1-4

Figure 1-3. Overall NDIR Method..... 1-5

Figure 1-4. Paramagnetic Oxygen Analysis..... 1-6

Figure 1-5. Reaction of Galvanic Cell 1-7

Figure 1-6. Electrochemical Oxygen Sensor..... 1-8

Figure 1-7. CPU 1-9

Figure 1-8. ADIO Board..... 1-10

Figure 1-9. ADIO Block Diagram..... 1-12

Figure 1-10. PCMCIA Interface..... 1-14

Figure 1-11. Modem 1-15

Figure 1-12. 128MB Flash Drive 1-16

Figure 1-13. Pocket PC..... 1-18

Figure 1-14. Wireless LAN adapter..... 1-19

Figure 1-15. 500 Watts Power Supply 1-20

Figure 2-1. MicroCEM Outline and Mounting Dimensions..... 2-2

Figure 2-2. MicroCEM Gas Connections 2-4

Figure 2-3. MicroCEM Flow Diagram..... 2-4

Figure 2-4. MicroCEM Installation and Test Setup Configuration..... 2-5

Figure 2-5. MicroCEM Electrical Connections 2-6

Figure 2-6. MicroCEM Wiring Diagram 2-7

Figure 2-7. Leak Test Flow Method 2-14

Figure 2-8. Leak Test Manometer Method..... 2-15

Figure 3-1. Pocket PC..... 3-1

Figure 3-2. MicroCEM Front Panel 3-2

Figure 3-3. MicroCEM Pocket PC Display (Main Display Shown)..... 3-3

Figure 3-4. MicroCEM Menu 3-4

Figure 3-5. Pocket PC Alarms Screen 3-4

Figure 3-6. MicroCEM Login 3-6

Figure 3-7. Current User Indication..... 3-6

Figure 3-8. Range Settings 3-7

Figure 3-9. Auto Calibration Settings 3-8

Figure 3-10. Auto Calibration Time and Frequency 3-8

Figure 3-11. Manual Calibration..... 3-9

Figure 3-12. Manual Calibration Results..... 3-9

Figure 3-13. Limit Settings 3-10

Figure 3-14. Calibration Gas Settings..... 3-10

Figure 3-15. Maintenance Mode Settings 3-11

Figure 3-16. User Settings 3-17

Figure 3-17. Auto Logoff..... 3-17

Figure 3-18. View Data Logs..... 3-21

Figure 3-19. View Data Logs Table..... 3-22

Figure 3-20. Real-Time Web Page 3-23

Figure 3-21. Emissions Selection..... 3-24

Figure 3-22. Emissions Table 3-24

Figure 3-23. Calibration Table..... 3-25

Figure 3-24. Download Web Page 3-26

Figure 3-25. New Web Query 3-27

Figure 3-26. Auto Calibration 3-28

Figure 4-1. MicroCEM Software Block Diagram 4-1

Figure 5-1. MicroCEM Component Location..... 5-2

Model MicroCEM

Figure 5-2.	Converter Assembly	5-3
Figure 5-3.	Personality Modules and Backplane.	5-4
Figure 5-4.	Chemiluminescence Detector Assembly	5-6
Figure 5-5.	Chemiluminescence Detector Assembly – Exploded View	5-7

LIST OF TABLES

Table 2-1.	Interface Connections	2-11
Table 2-2.	AC Power Connection Terminal Assignments.....	2-11
Table 2-3.	Analog Output Terminal Assignments	2-11
Table 2-4.	Digital Output Terminal Assignments	2-12
Table 2-5.	RS-232 Interface Terminal Assignments	2-13
Table 2-6.	RS-485 Terminal Assignments	2-13
Table 2-7.	LAN Interface Terminal Assignments	2-13
Table 2-8.	Phone Line (Modem) Terminal Assignments	2-13
Table 2-9.	Antenna (Peltier Power) Connection Terminal Assignments	2-14
Table 3-1.	Status Values	3-3
Table 3-2.	Alarm Summary	3-5
Table 3-3.	Factory Settings – Calibration.....	3-13
Table 3-4.	Factory Settings - General.....	3-14
Table 3-5.	PID Settings – Section Names	3-15
Table 3-6.	PID Settings – Sections Descriptions	3-16
Table 3-7.	Measurement Log File Format.....	3-18
Table 3-8.	Calibration Log File Format	3-19
Table 3-9.	Alarm Log File Format	3-20
Table 3-10.	Average Period Selection	3-21

PREFACE

The purpose of this manual is to provide information concerning the components, functions, installation and maintenance of the MicroCEM.

Some sections may describe equipment not used in your configuration. The user should become thoroughly familiar with the operation of this module before operating it. Read this instruction manual completely.

DEFINITIONS

The following definitions apply to DANGERS, WARNINGS, CAUTIONS and NOTES found throughout this publication.

DANGER

Highlights the presence of a hazard which will cause severe personal injury, death, or substantial property damage if the warning is ignored.

WARNING

Highlights an operation or maintenance procedure, practice, condition, statement, etc. If not strictly observed, could result in injury, death, or long-term health hazards of personnel.

CAUTION

Highlights an operation or maintenance procedure, practice, condition, statement, etc. If not strictly observed, could result in damage to or destruction of equipment, or loss of effectiveness.

NOTE

Highlights an essential operating procedure, condition or statement.

INTENDED USE STATEMENT

The MicroCEM Continuous Emissions Monitor is intended for use as an industrial process measurement device only. It is not intended for use in medical, diagnostic, or life support applications, and no independent agency certifications or approvals are to be implied as covering such applications.

SAFETY SUMMARY

If this equipment is used in a manner not specified in these instructions, protective systems may be impaired.

AUTHORIZED PERSONNEL

To avoid explosion, loss of life, personal injury and damage to this equipment and on-site property, do not operate or service this instrument before reading and understanding this instruction manual and receiving appropriate training. Save these instructions.

DANGER

ELECTRICAL SHOCK HAZARD

Do not open while energized. Installation requires access to live parts which can cause death or serious injury.

For safety and proper performance this instrument must be connected to a properly grounded three-wire source of power.

DANGER

POSSIBLE EXPLOSION HAZARD

Do not operate without covers secure. Ensure that all gas connections are made as labeled and are leak free. Improper gas connections could result in explosion and death.

DANGER

TOXIC GAS

This device may contain explosive, toxic or unhealthy gas components. Before cleaning or changing parts in the gas paths, purge the gas lines with ambient air or nitrogen.

This unit's exhaust may contain hydrocarbons and other toxic gases such as carbon monoxide. Carbon monoxide is highly toxic and can cause headache, nausea, loss of consciousness, and death.

Avoid inhalation of the exhaust gases at the exhaust fitting.

Connect exhaust outlet to a safe vent using stainless steel or Teflon line. Check vent line and connections for leakage.

Keep all tube fittings tight to avoid leaks. See Sections 2-5 for leak check information.

WARNING

DEVICE HAZARDOUS AREA CERTIFICATION(S)

Any addition, substitution, or replacement of components installed on or in this device, must be certified to meet the hazardous area classification that the device was certified to prior to any such component addition, substitution, or replacement. In addition, the installation of such device or devices must meet the requirements specified and defined by the hazardous area classification of the unmodified device. Any modifications to the device not meeting these requirements, will void the product certification(s).

WARNING

PARTS INTEGRITY AND UPGRADES

Tampering with or unauthorized substitution of components may adversely affect the safety of this instrument. Use only factory approved components for repair.

Because of the danger of introducing additional hazards, do not perform any unauthorized modification to this instrument.

Return the instrument to Rosemount Analytical Customer Service Center. See Section 8.

CAUTION

PRESSURIZED GAS

This unit requires periodic calibration with a known standard gas. It also may utilize a pressurized carrier gas, such as helium, hydrogen, or nitrogen. See General Precautions for Handling and Storing High Pressure Gas Cylinders, page P-5.

CAUTION

HEAVY WEIGHT

Use two persons or a suitable lifting device to move or carry the instrument.

GENERAL PRECAUTIONS FOR HANDLING AND STORING HIGH PRESSURE GAS CYLINDERS

Edited from selected paragraphs of the Compressed Gas Association's "Handbook of Compressed Gases" published in 1981

**Compressed Gas Association
1235 Jefferson Davis Highway
Arlington, Virginia 22202
Used by Permission**

1. Never drop cylinders or permit them to strike each other violently.
2. Cylinders may be stored in the open, but in such cases, should be protected against extremes of weather and, to prevent rusting, from the dampness of the ground. Cylinders should be stored in the shade when located in areas where extreme temperatures are prevalent.
3. The valve protection cap should be left on each cylinder until it has been secured against a wall or bench, or placed in a cylinder stand, and is ready to be used.
4. Avoid dragging, rolling, or sliding cylinders, even for a short distance; they should be moved by using a suitable hand-truck.
5. Never tamper with safety devices in valves or cylinders.
6. Do not store full and empty cylinders together. Serious suckback can occur when an empty cylinder is attached to a pressurized system.
7. No part of cylinder should be subjected to a temperature higher than 125°F (52°C). A flame should never be permitted to come in contact with any part of a compressed gas cylinder.
8. Do not place cylinders where they may become part of an electric circuit. When electric arc welding, precautions must be taken to prevent striking an arc against the cylinder.

DOCUMENTATION

The following MicroCEM instruction materials are available. Contact Customer Service Center or the local representative to order (See Section 8).

748467 Instruction Manual (this document)

748468 Instruction Manual, MicroCEM Sample Handling System

COMPLIANCES

This product may carry approvals from several certifying agencies. The certification marks appear on the product name-rating plate.

CSA (Pending)

SECTION 1 DESCRIPTION AND SPECIFICATIONS

1-1 OVERVIEW

The MicroCEM Analyzer Module is designed to continuously determine the concentration of O₂, CO, and NO_x in a flowing gaseous mixture. The concentration is expressed in percent (%) or parts-per-million (PPM).

The sampled gas is collected from the stack and prepared by the Probe/Sample Handling System for analysis and processing by the Analysis Enclosure. The Analysis Enclosure shall be a standalone, computer-controlled unit, utilizing PC/104 as the system bus.

The MicroCEM is enclosed in a rugged NEMA 4X, IP65 type enclosure, for harsh environment. The analysis enclosure utilizes convection cooling with no air intake and air vents. The analysis enclosure is modular, general purpose and easily expandable. It utilizes industry standard components such as PC/104 boards, and modular signal conditioning modules.

1-2 TYPICAL APPLICATIONS

SCR
Emission Compliance per EPA 40 CFR Part 60
Gas Turbines
Natural Gas Fired Boilers
Process Heaters

1-3 THEORY OF OPERATION

a. Chemiluminescence NO_x

The NO_x analyzer continuously analyzes a flowing gas sample for NO_x [nitric oxide (NO) plus nitrogen dioxide (NO₂)]. The sum of the concentrations is continuously reported as NO_x.

The MicroCEM NO_x Analyzer Module uses the chemiluminescence method of detection. This technology is based on NO's reaction with ozone (O₃) to produce

NO₂ and oxygen (O₂). Some of the NO₂ molecules produced are in an electronically excited state (NO₂* where the * refers to the excitation). These revert to the ground state, with emission of photons (essentially, red light). The reactions involved are:

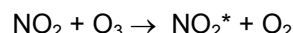

The sample is continuously passed through a heated bed of vitreous carbon, in which NO₂ is reduced to NO. Any NO initially present in the sample passes through the converter unchanged, and any NO₂ is converted to an approximately equivalent (95%) amount of NO.

The NO is quantitatively converted to NO₂ by gas-phase oxidation with molecular ozone produced within the analyzer from air supplied by an external source. During the reaction, approximately 10% of the NO₂ molecules are elevated to an electronically excited state, followed by immediate decay to the non-excited state, accompanied by emission of photons. These photons are detected by a photomultiplier tube which produces an output proportional to the concentration of NO_x in the sample.

To minimize system response time, an internal sample bypass feature provides high-velocity sample flow through the analyzer.

b. Non-Dispersive Infrared (NDIR) CO

The optical bench can selectively measure multiple components in a compact design by using a unique dual optical bench design. Depending on the application, any two combinations of NDIR channels can be combined on a single chopper motor/dual source assembly.

Other application-dependent options include a wide range of sample cell materials, optical filters and solid state detectors. The NDIR Microflow detector consists of two chambers, measurement and reference with an interconnected path in which an ultra low flow filament sensor is mounted. During operation, a pulsating flow occurs between the two chambers which is dependent upon: sample gas absorption, modulation by the chopper motor and the fill gas of the detector chambers. The gas flow/sensor output is proportional to the measured gas concentration. The optical bench is further enhanced by a novel "Look-through" detector technique. This design allows two detectors to be arranged in series --- enabling two different components to be measured on a single optical bench. The optical bench contains a unique eddy current drive chopper motor and source assembly. This design incorporates on board "intelligence" to provide continuous "self test" diagnostics.

c. Paramagnetic O₂

The determination of oxygen is based on the measurement of the magnetic susceptibility of the sample gas. Oxygen is strongly paramagnetic, while other common gases are not. The detector used is compact, has fast response and a wide dynamic range. The long life cell is corrosion resistant, heated and may be easily cleaned. It has rugged self-tensioning suspension and is of welded non-glued construction.

1-4 DETECTOR METHODOLOGIES

The MicroCEM can employ up to three different measuring methods depending on the configuration chosen. The methods are: NDIR, Paramagnetic O₂, Electrochemical O₂, and Chemiluminescence.

a. Non-Dispersive Infrared (NDIR)

The non-dispersive infrared method is based on the principle of absorption of infrared radiation by the sample gas being

measured. The gas-specific wavelengths of the absorption bands characterize the type of gas while the strength of the absorption gives a measure of the concentration of the gas component being measured.

An optical bench is employed comprising an infrared light source, two analysis cells (reference and measurement), a chopper wheel to alternate the radiation intensity between the reference and measurement side, and a photometer detector. The detector signal thus alternates between concentration dependent and concentration independent values. The difference between the two is a reliable measure of the concentration of the absorbing gas component.

Depending on the gas being measured and its concentration, one of two different measuring methods may be used as follows:

Interference Filter Correlation (IFC) Method

With the IFC method the analysis cell is alternately illuminated with filtered infrared concentrated in one of two spectrally separated wavelength ranges. One of these two wavelength bands is chosen to coincide with an absorption band of the sample gas and the other is chosen such that none of the gas constituents expected to be encountered in practice absorbs anywhere within the band.

The spectral transmittance curves of the interference filters used in the MicroCEM analyzer and the spectral absorption of the gases CO and CO₂ are shown in Figure 1-1. It can be seen that the absorption bands of these gases each coincide with the passbands of one of the interference filters. The fourth interference filter, used for generating a reference signal, has its passband in a spectral region where none of these gases absorb. Most of the other gases of interest also do not absorb within the passband of this reference filter.

The signal generation is accomplished with a pyroelectrical (solid-state) detector. The detector records the incoming infrared radiation. This radiation is reduced by the absorption of the gas at the corresponding wavelengths. By comparing the measurement and reference wavelength, an alternating voltage signal is produced. This signal results from the cooling and heating of the pyroelectric detector material.

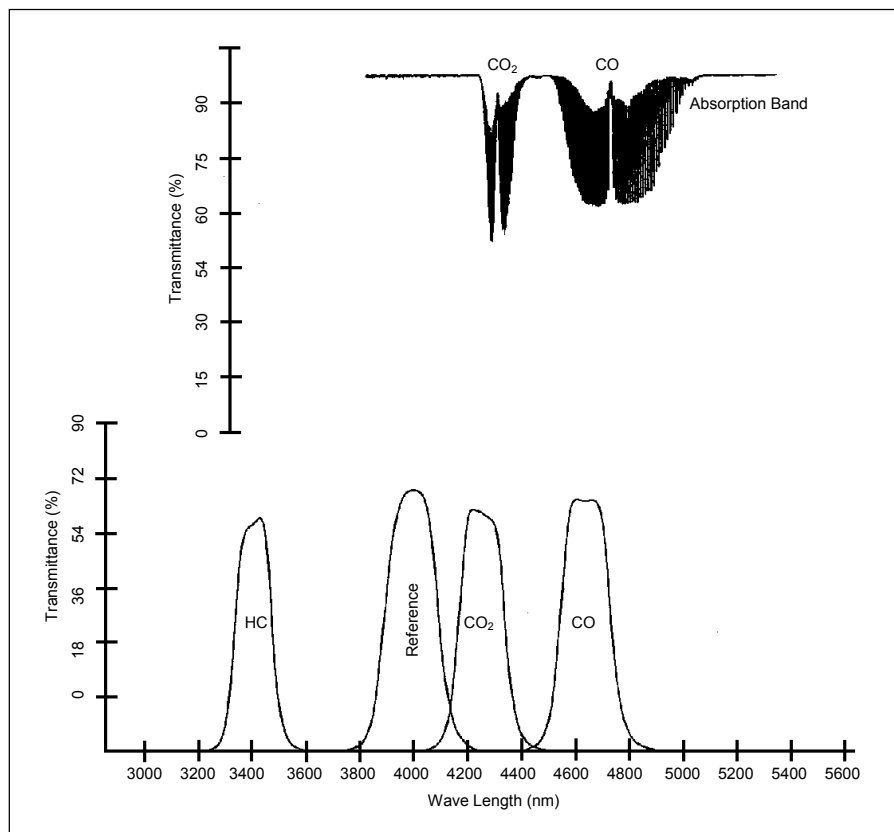

Figure 1-1. Absorption Bands of Sample Gas and Transmittance of Interference Filters

Opto-Pneumatic Method

In the opto-pneumatic method, a thermal radiator generates the infrared radiation which passes through the chopper wheel. This radiation alternately passes through the filter cell and reaches the measuring and reference side of the analysis cell with equal intensity. After passing another filter cell, the radiation reaches the pneumatic detector.

The pneumatic detector compares and evaluates the radiation from the measuring and reference sides of the analysis cell and converts them into voltage signals proportional to their respective intensity.

The pneumatic detector consists of a gas-filled absorption chamber and a compensation chamber which are connected by a flow channel in which a Microflow filament sensor is mounted. This is shown in Figure 1-2.

In principle the detector is filled with the infrared active gas to be measured and is only sensitive to this distinct gas with its characteristic absorption spectrum. The absorption chamber is sealed with a window which is transparent for infrared radiation. The window is usually Calcium Fluoride (CaF₂).

When the infrared radiation passes through the reference side of the analysis cell into the detector, no pre-absorption occurs. Thus, the gas inside the absorption chamber is heated, expands and some of it passes through the flow channel into the compensation chamber.

When the infrared radiation passes through the open measurement side of the analysis cell into the detector, a part of it is absorbed depending on the gas concentration. The gas in the absorption chamber is, therefore, heated less than in the case of radiation coming from the reference side. Absorption chamber gas becomes cooler, gas pressure in the absorption chamber is reduced and some gas from the compensation chamber passes through the flow channel into the absorption chamber.

The flow channel geometry is designed in such a way that it hardly impedes the gas flow by restriction. Due to the radiation of the chopper wheel, the different radiation intensities lead to periodically repeated flow pulses within the detector.

The Microflow sensor evaluates these flow pulses and converts them into electrical pulses which are processed into the corresponding analyzer output.

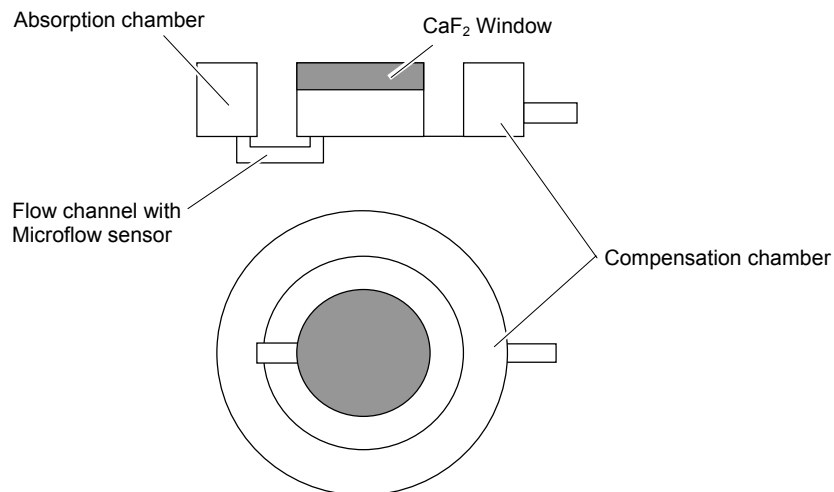

Figure 1-2. Opto-Pneumatic Gas Detector

Overall NDIR Method

In the case of dual-channel analyzers, the broadband emission from two infrared sources pass through the chopper wheel. In the case of the Interference Filter Correlation (IFC) method, the infrared radiation then passes through combinations of interference filters. In the case of the opto-pneumatic method, the infrared radiation passes through an optical filter

depending on the application and need for reduction of influences. Then the infrared radiation enters the analysis cells from which it is focused by filter cells onto the corresponding detector. The preamplifier detector output signal is then converted into the analytical results expressed directly in the appropriate physical concentration units such as percent volume, ppm, mg/Nm³, etc. This is shown in Figure 1-3.

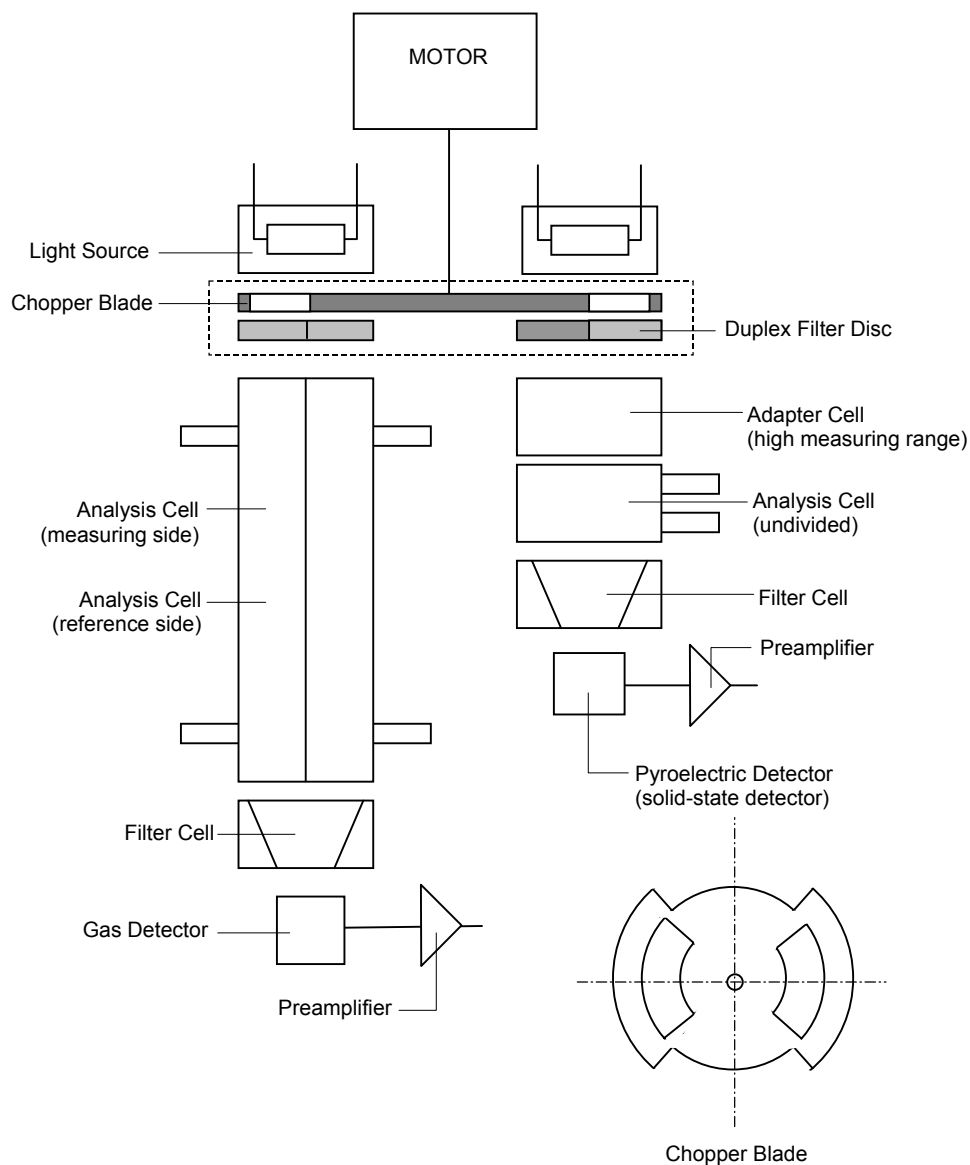

Figure 1-3. Overall NDIR Method

b. Paramagnetic Oxygen Method

The paramagnetic principle refers to the induction of a weak magnetic field, parallel and proportional to the intensity of a stronger magnetizing field.

The paramagnetic method of determination of oxygen concentration utilizes nitrogen filled quartz spheres arranged at opposite ends of a bar, the center of which is suspended by and free to rotate on a thin platinum wire ribbon in a cell. Nitrogen (N₂) is used because it is diamagnetic or repelled by a magnet.

A small mirror that reflects a light beam coming from a light source to a photodetector, is mounted on the platinum ribbon. A strong permanent magnet specifically shaped to produce a strong, highly inhomogeneous magnetic field inside the analysis cell, is mounted outside the wall of the cell.

When oxygen molecules enter the cell, their paramagnetism will cause them to

be drawn towards the region of greatest magnetic field strength. The oxygen molecules thus exert different forces on the two suspended nitrogen filled quartz spheres, producing a torque which causes the mirror to rotate away from its equilibrium position.

The rotated mirror deflects the incident light onto the photodetector creating an electrical signal which is amplified and fed back to a coil attached to the bar holding the quartz spheres, forcing the suspended spheres back to the equilibrium position.

The current required to generate the restoring torque to return the quartz bar to its equilibrium position is a direct measure of the O₂ concentration in the sample gas.

The complete paramagnetic analysis cell consists of an analysis chamber, permanent magnet, processing electronics, and a temperature sensor. The temperature sensor is used to control a heat exchanger to warm the measuring gas to about 55 °C. Refer to Figure 1-4.

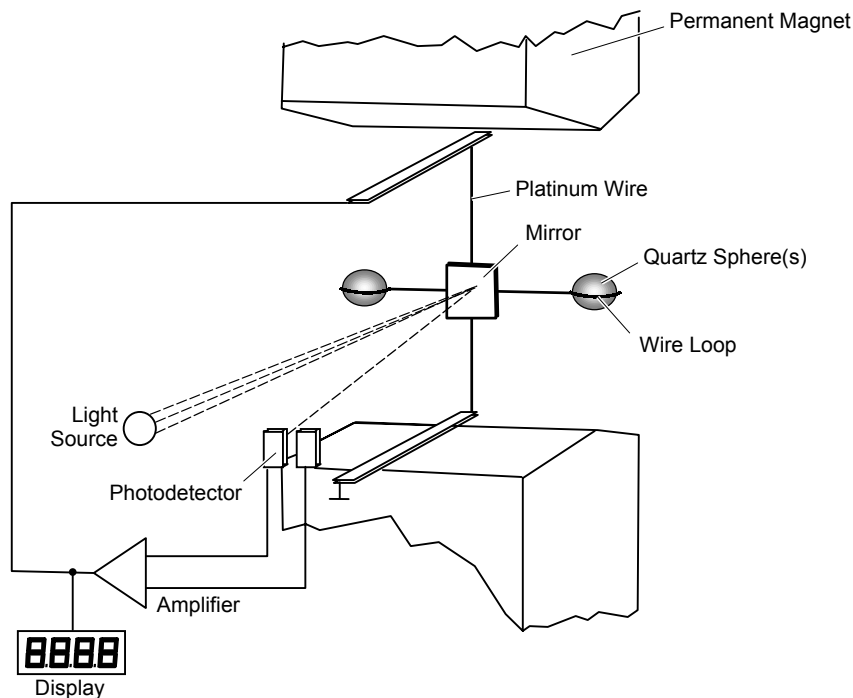

Figure 1-4. Paramagnetic Oxygen Analysis

c. Electrochemical Oxygen Method

The electrochemical method of determining oxygen concentration is based on the galvanic cell principle shown in Figure 1-5.

The electrochemical oxygen sensor (Figure 1-6) incorporates a lead and gold galvanic process with a lead anode and a gold cathode, using an acid electrolyte.

Oxygen molecules diffuse through a non-porous Teflon membrane into the electrochemical cell and are reduced at the gold cathode. Water is the byproduct of this reaction.

On the anode, lead oxide is formed which is transferred into the electrolyte. The lead anode is continuously regenerated and, therefore, the electrode potential remains unchanged for a long time. The rate of diffusion and corresponding response time (t_{90}) of the sensor is dependent on the thickness of the Teflon membrane.

The electric current between the electrodes is proportional to the O_2 concentration in the sample gas being measured. The resultant signal is measured as a voltage across the resistor and thermistor, the latter of which is used for temperature compensation. A change in the output voltage (mV) represents oxygen concentration.

NOTE

The electrochemical O_2 cell requires a minimum internal consumption of oxygen. Sample gases with an oxygen concentration of less than 2% could result in a reversible detuning of sensitivity and the output will become unstable. The recommended practice is to purge the cell with conditioned ambient air between periods of measurement. If the oxygen concentration is below 2% for several hours or days, the cell must be regenerated for about one day with ambient air. Temporary flushing with nitrogen (N_2) for less than one hour (analyzer zeroing) will have no effect on the sensitivity or stability.

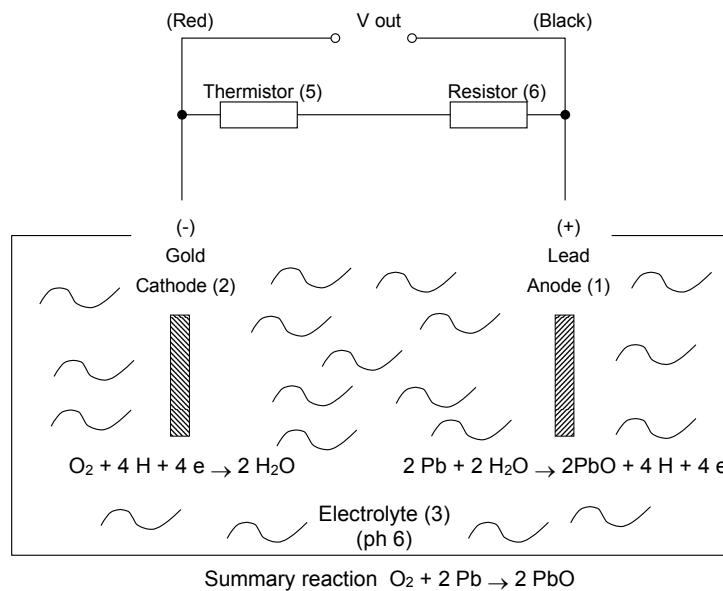

Figure 1-5. Reaction of Galvanic Cell

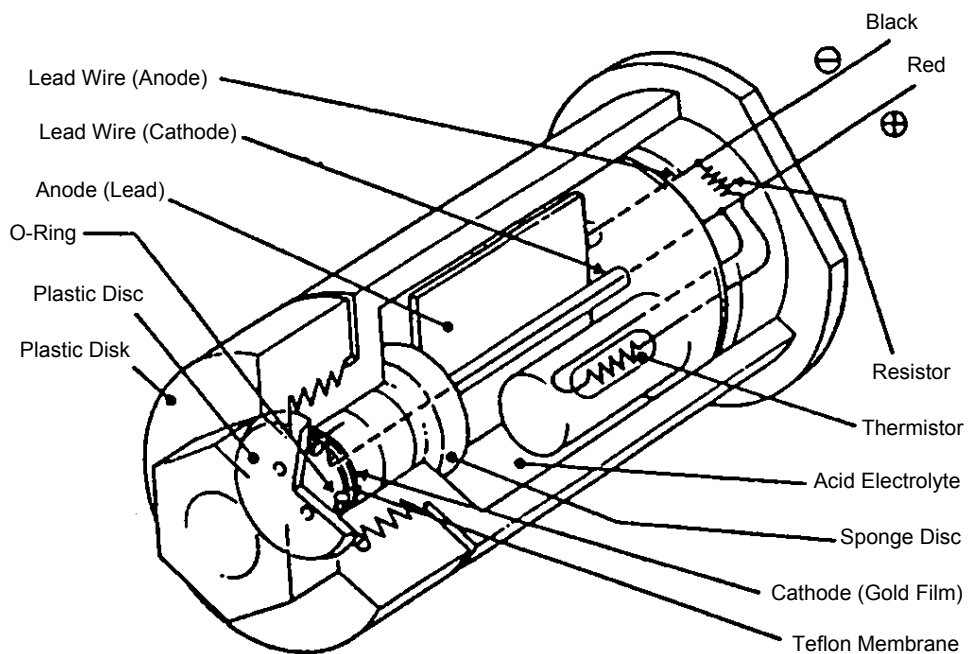

Figure 1-6. Electrochemical Oxygen Sensor

Model MicroCEM

1-5 CENTRAL PROCESSING UNIT

The CPU is an Embedded Pentium-like AT Computer in 5.75" x 8" form factor. The peripherals integrated on board are: SVGA, 4 serial ports and one parallel port, Fast Ethernet ctrl., IDE, Keyboard, Mouse, 2 USB. The module is built around the Intel Tillamook processor and is equipped with 64MB SDRAM. The module also integrates one socket for SSD that performs like an HDD unit and can be used to store the operating system, the user's programs and the data files. Other peripherals available on board are the Floppy disk controller, the parallel port. The CPU is shown in Figure 1-7.

a. Embedded Enhanced Bios

Award, 256KB Flash Bios. The Bios is immediately activated when you first turn on the system. The Bios reads system configuration information in CMOS RAM and begins the process of checking out the system.

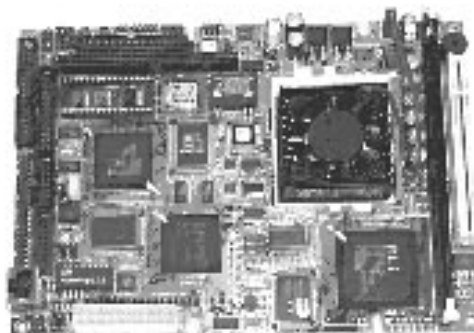

Figure 1-7. CPU

b. Specifications

- Architecture: PC/AT Compatible
- Dimensions: 5.75" x 8"
- Processor: Intel Tillamook processor - 266MHz
- Memory: 64 MB SDRAM
- Ram/Rom disk: 1 x 32 pin socket (max. 288MB)
- Operating System: WinNT
- BIOS: Standard with embedded extensions
- Interfaces: IDE ctrl
 - Floppy ctrl
 - SVGA-CRT
 - 10/100 Mbps Fast Ethernet
 - 2 USB ports
 - 4 RS232 serial ports (one can be 485)
 - Parallel port (bi-directional EPP-ECP)
 - Keyboard PS/2
 - Mouse PS/2
- Bus: AT bus according to PC/104 spec.
- Power Supply: AT/ATX
- Connectors: COM1-4, SVGA, USB 1 and 2, PS/2 Mouse/Keyboard, ATX Power, Parallel, IDE, Floppy, and Fast Ethernet

1-6 ANALOG/DIGITAL I/O BOARD

The Analog/Digital IO (ADIO) Board is an off-the-shelf, complete data acquisition system in a compact PC/104 packaging. The analog section contains 32 input channels, multiplexed A/D converter with 16 bit resolution and 10uS conversion time. Input ranges are +/-5v or +/- 10V. It also includes on-board DMA support. The analog output section includes two 12 bit D/A converters. Both sections features simplified calibration using on board programmable digital potentiometer. The digital I/O section provides 24 digital I/O lines, which feature high current TTL drivers. The board requires only +5V from the system power supply and generates its own +/-15V analog supplies on board. The board operates over the Extended Temperatures range of -25 to +85C. Figure 1-8 depicts the ADIO board and Figure 1-9 depicts the ADIO block diagram.

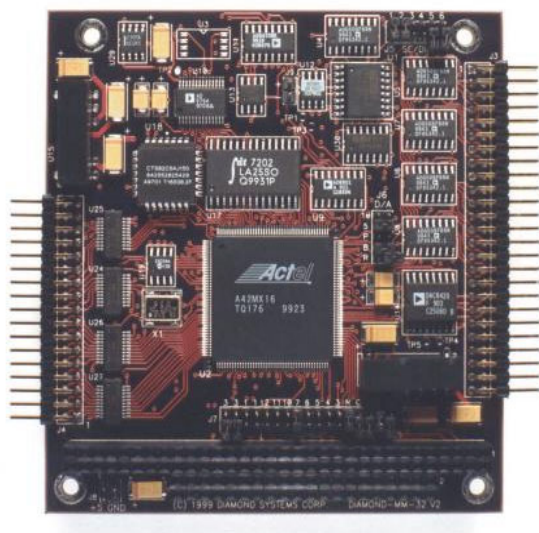

Figure 1-8. ADIO Board

a. Automatic Calibration

The ADIO board features automatic calibration of both analog inputs and outputs for enhanced accuracy and reliability. The potentiometers, which are subject to tampering and vibration, have been eliminated. Instead, all A/D calibration adjustments are performed using an octal 8-bit DAC. The DAC values are stored in an EEPROM and are recalled automatically on power up. The board includes three precision voltage references for negative full scale, zero, and positive full-scale. A calibration utility program provided with the board allows you to recalibrate the board anytime, in both unipolar and bipolar modes, and store the new settings in EEPROM.

Autocalibration applies to the 4 D/A channels as well. The full-scale D/A range is selected with a jumper block. The analog outputs are fed back to the A/D converter so they can be calibrated without user intervention. Again, calibration settings are stored in EEPROM and automatically recalled on power-up.

b. Analog Inputs

The ADIO board provides split configuration capability, with more total input channels than any other PC/104 analog I/O board. The board can be user-configured in any of three ways:

Channels	Format
32	32 single-ended
24	8 differential, 16 single-ended
16	16 differential

Model MicroCEM

c. Programmable Input Ranges

A programmable gain amplifier, programmable unipolar/bipolar range, and programmable 5V/10V full-scale range combine to give the ADIO board a total of 10 different possible analog input ranges. All range settings are controlled in software for maximum flexibility.

Mode	Full-scale	Gain	Input Range	Resolution
Unipolar	10V	1	0-10V	0.153mV
Unipolar	5V	1	0-5V	0.076mV
Unipolar	5V	2	0-2.5V	0.038mV
Unipolar	5V	4	0-1.25V	0.019mV
Unipolar	5V	8	0-0.625V	0.0096mV
Bipolar	10V	1	±10V	0.305mV
Bipolar	5V	1	±5V	0.153mV
Bipolar	5V	2	±2.5V	0.076mV
Bipolar	5V	4	±1.25V	0.038mV
Bipolar	5V	8	±0.625V	0.019mV

d. Enhanced Trigger and Sampling Control Signals

The ADIO board has an extra A/D trigger and sample control signals in the design. Seven auxiliary digital I/O lines on the analog I/O connector provide a sample/hold output signal, A/D trigger in and out lines (to enable synchronization of multiple boards) and external A/D clocking.

e. Analog Outputs

The ADIO board contains 4 12-bit analog outputs with autocalibration capability. Up to 5mA of output current per channel can be drawn from all channels simultaneously. Both unipolar and bipolar output ranges are supported with jumper configuration. And on power up, all outputs are reset to 0V automatically.

Mode	Full-scale	Output Range	Resolution
Unipolar	10V	0-10V	2.44mV
Unipolar	5V	0-5V	1.22mV
Bipolar	10V	±10V	4.88mV
Bipolar	5V	±5V	2.44mV

f. FIFO and 16-Bit Bus Interface

An on-board 1024-byte FIFO enables the ADIO board to work with Windows 95 and NT by dramatically reducing the interrupt overhead. Each interrupt transfers 256 2-byte samples, or half the buffer, so the interrupt rate is 1/256 the sample rate. FIFO operation can be disabled at slow sample rates, so there is no lag time between sampling and data availability. The 16-bit interface further reduces software overhead by enabling all 16 A/D bits to be read in a single instruction, instead of requiring 2 8-bit read operations. The net result of this streamlined design is that the ADIO board supports gap-free A/D sampling at rates up to 200,000 samples per second, twice as fast as our previous boards.

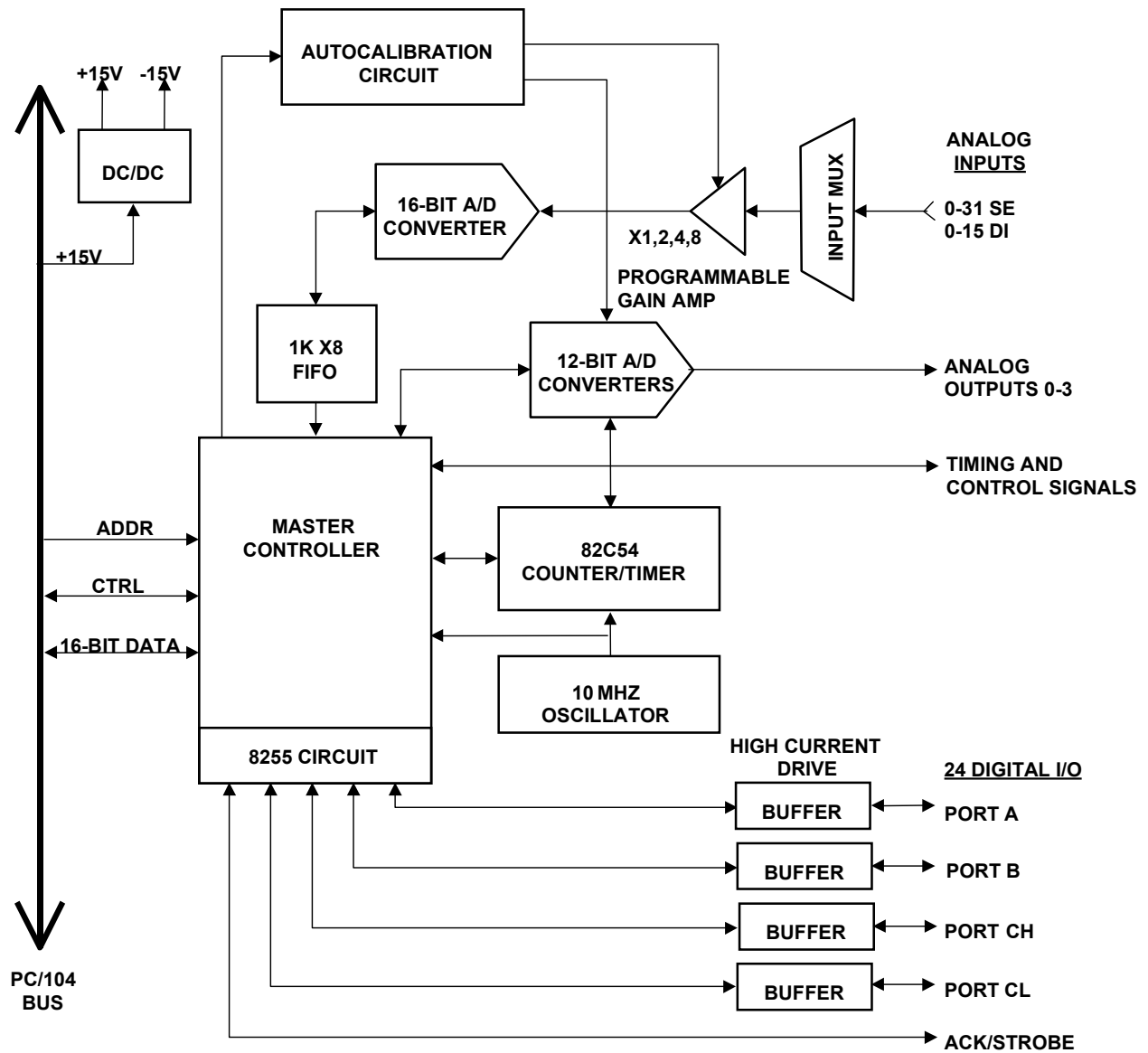

Figure 1-9. ADIO Block Diagram

g. Specifications

Analog Inputs

Number of inputs	32 single-ended, 16 differential, or 16 SE + 8 DI; user selectable
A/D resolution	16 bits (1/65,536 of full scale)
Bipolar ranges	$\pm 10V$, $\pm 5V$, $\pm 2.5V$, $\pm 1.25V$, $\pm 0.625V$
Unipolar ranges	0-10V, 0-5V, 0-2.5V, 0-1.25V, 0-.625V,
Input bias current.....	100pA max
Overvoltage protection	$\pm 35V$ on any analog input without damage
Nonlinearity.....	$\pm 3LSB$, no missing codes
Conversion rate	200,000 samples/sec.max
On-board FIFO	1K x 8(512 16-bit samples)
Calibration.....	Automatic; values stored in EEPROM

Analog Outputs

Number of outputs	4
D/A resolution	12 bits (1/4096 of full scale)
Output ranges.....	± 5 , ± 10 , 0-5, 0-10
Output current.....	$\pm 5mA$ max per channel
Settling time	6 μ S max to 0.01%
Relative accuracy	± 1 LSB
Nonlinearity.....	± 1 LSB, monotonic
Reset	All channels reset to OV
Calibration.....	Automatic; values stored in EEPROM

Digital I/O

Main I/O	24 programmable I/O
Input current.....	$\pm 1\mu A$ max
Output current.....	
Logic 0	64mA max per line
Logic 1	-15mA max per line
Auxiliary I/O	4 inputs, 4 outputs, optional use as trigger/control lines

Counter/Timers

A/D Pacer clock.....	32-bit down counter (2 82C54 counters cascaded)
Clock source	10MHz on-board clock or external signal
General purpose	16-bit down counter (1 82C54 counter)

General

Power supply	+5VD $\pm 10\%$ @200mA typ
Operating temperature	-25 to +85°C
Weight.....	3.4oz/96g

1-7 PCMCIA ADAPTER

The PCMCIA adapter board (Figure 1-10) supports Type I, II and III PCMCIA cards. The board is in full compliance with Microsoft FFS-II, PCMCIA V.2 and JEIDA 4.1 specifications. The PCMCIA socket accepts The following PCMCIA cards:

- Type I Memory, Flash/SRAM/ROM
- Type II Fax, Modem, LAN, Wireless LAN, and SCSI
- Type III ATA mass storage

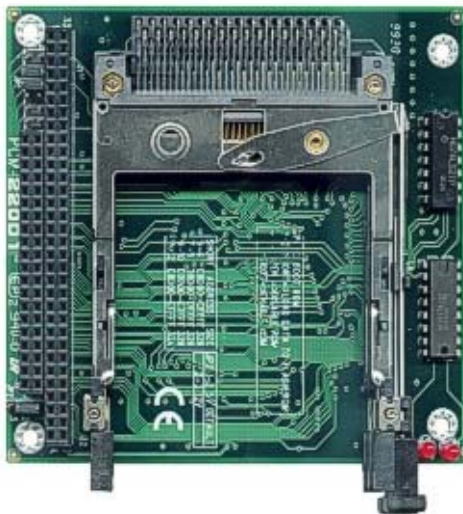

Figure 1-10. PCMCIA Interface

a. Features

Dimensions

Compliant with the PC/104 standard
Compatible with AT PC/104 CPU modules

Functions on board

2 PCMCIA slots
Optional remote socket

PCMCIA features

Supports PCMCIA V.1.0 and V.2.0
Supports PCMCIA types I, II and III
Supports both I/O and Memory Card
Supports Hot insertion

Operating Systems

DOS and Windows and any other RTOS that supports PCMCIA

Connectors

- J1 : PCMCIA 2 slots connector
- J3: PC/104 8 bit connector (XT compatible)
- J4 : PC/104 16 bit extension (AT extension compatible).

b. Software

Software mappable memory windows and one I/O window.

Jumperless interrupt steering from PC Card to system.

Complete set of device drivers complying with PCMCIA V2.1 /JEIDA V4.1, running under MS-DOS or MS-WINDOWS:

- PCMCIA socket & card services drivers
- Flash File System

Model MicroCEM

1-8 MODEM

The PC/104 Modular Modem is a self-contained modem module that provides the flexibility to include modem functionality into embedded system, with minimal engineering resources. The PC/104 Modular Modem is full featured including high-speed data and fax transmission. The PC/104 Modular Modems support both dial-up and 2-wire leased-line. Figure 1-11 depicts the Modem.

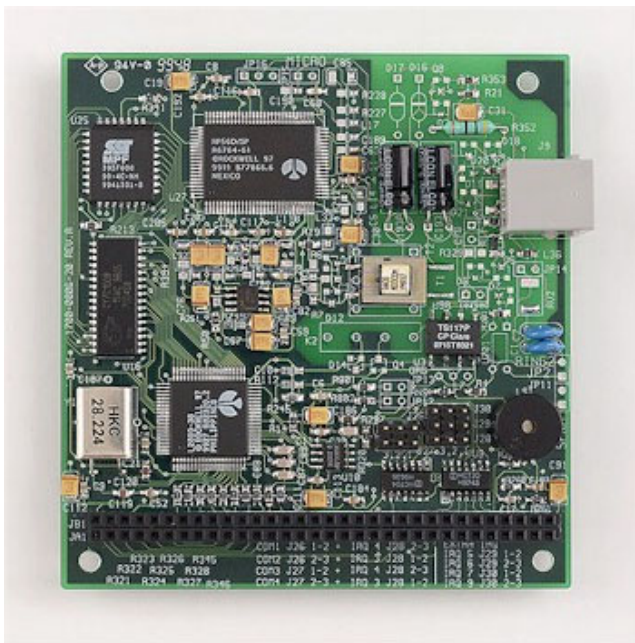

Figure 1-11. Modem

a. Features

V.90, 56 kbps data (560PC/104)

V.34, 33.6 kbps data (336PC/104)

14.4 kbps fax

Voice playback and record

DTMF decode

-40°C to 85°C operation

3.775" x 3.550" x 0.568" (with modular phone jack)

3.775" x 3.550" x 0.435" (without modular phone jack)

8 bit PC/104 bus type

V.42 and MNP 2-4 error correction

V.42bis, and MNP-5 data compression

FCC Part 68 registered

FCC Part 15 compliant

2 wire leased-line and dial up support

Industry Canada CS-03 certified

1-9 FLASH DRIVE



Figure 1-12. 128MB Flash Drive

a. Specifications

System Performance

All values quoted are typical at ambient temperature and nominal supply voltage unless otherwise stated.

All performance timing assumes the controller is in the default (i.e., fastest) mode.

Start-up Time

Sleep to Write.....	2.5 msec max.
Sleep To Read	2.5 msec max.
Reset to Ready.....	50 msec typical, 400 msec max.
Data Transfer Rate	
to/from host.....	16.0 MB/sec burst
Active to Sleep Delay	Programmable
Controller Overhead	
Command to DRQ	<1.25 msec

Power Requirements

All values quoted are typical at ambient temperature and nominal supply voltage unless otherwise stated.

DC Input Voltage

Commercial	3.3 V ± 5%, 5 V ± 10%
Industrial	3.3 V ± 5%, 5 V ± 5%

Model MicroCEM

Power Dissipation

Sleep mode currently is specified under the condition that all card inputs are static CMOS levels and in a "Not Busy" operating state.

The currents specified show the bounds of programmability of the product.

Sleep	200 μ A @3.3 V	500 μ A @5.0 V
Read	35 mA RMS @3.3 V	50 mA RMS @5.0 V
Write	35 mA RMS @3.3 V	50 mA RMS @5.0 V

Environmental Specifications

Temperature

Operating Commercial	0°C to 60°C
Operating Industrial	-40°C to 85°C
Non-Operating Commercial ..	-25°C to 85°C
Non-Operating Industrial	-50°C to 100°C

Humidity

Operating	8% to 95%, non-condensing
Non-Operating	8% to 95%, non-condensing
Acoustic Noise	0dB

Vibration

Operating	15 G peak to peak max.
Non-Operating	15 G peak to peak max.

Shock

Operating	1,000 G max.
Non-Operating	1,000 G max.

Altitude (relative to sea level)

Operating/Non-Operating	80,000 feet max.
-------------------------------	------------------

System Reliability and Maintenance

MTBF ¹	>1,000,000 hours
Preventive Maintenance	None
Data Reliability	<1 non-recoverable error in 10 ⁽¹⁴⁾ bits read

Physical Specifications

Length.....	100.2mm \pm 0.51mm
Width	69.85mm \pm 0.51mm
Thickness (Body)	9.6mm \pm 5.0mm
Thickness (Removable Edge)	N/A
Weight	160 g. max

¹ Mean Time Between Failures

1-10 POCKET PC

The Pocket PC acts as an Graphic User Interface to the MicroCEM unit.

a. Specifications

Processor	133MHz 32-bit Hitachi SH3 processor
Memory	32MB RAM, 16MB ROM
Display	240 x 320 pixels LCD, Rich-color CSTN, backlit
User Interface	Pen-and-touch interface (stylus included) Handwriting recognition software On-screen keyboard 4 user-configurable quick launch screen icons 2 quick keys (Record and Scroll/Action) Notification LED
Power	Built-in Lithium-Ion rechargeable battery 8 hours of battery life 1 Worldwide auto-voltage AC adapter
Input/Output	IrDA infrared port RS232 serial port USB port Compact Flash Type I card slot AC input jack Stereo earphone jack
Sound	Audio speaker and microphone Built-in voice recorder Digital audio player compatible
Other Standard Features.....	USB cradle Serial cable Earphones Removable metal cover Password protected and DMI compatible
Dimensions	5.2 x 3.1 x 0.6 in (13 x 7.8 x 1.6 cm)
Weight	9.1 oz (260 g) with battery
Operating Temperature	32–104° F (0–40° C)
Storage Temperature	32–140° F (0–60° C)
Humidity.....	90% relative humidity at 104° F (40° C)



Figure 1-13. Pocket PC

Model MicroCEM

1-11 WIRELESS LAN ADAPTER

Wireless LAN adapter is an option to allow the user to remove the Pocket PC from the enclosure and to operate the MicroCEM from a distance up to 1000 feet. Figure 1-14 depicts the wireless LAN adapter.



Figure 1-14. Wireless LAN Adapter

a. Specifications

Data Rate	11 Mbps send/receive with automatic fallback for extended range
Useful Range.....	Up to 1000 feet (300 meters) open field; 300 feet (90 meters) typical indoor installations (intervening metal and thick concrete structures degrade performance and range)
Security.....	Supports Wired Equivalent Privacy (WEP) which provides 64-bit and 128-bit data encryption; additional security through the use of a 32-character network system ID
Standard Support	Interoperable with 2 Mbps IEEE 802.11 Direct Sequence Spread Spectrum (DSSS) and 802.11b (11 and 5.5 Mbps) extension
OS Support.....	NDIS drivers included for Windows 95, 98, ME and NT and 2000
Channels	Supports 11 US/Canada and 13 ETSI selectable, fully-independent channels
Transmit Power	25mW typical
Radio Frequency	2.4 to 2.4835 GHz
Power Requirement.....	PC Card: 5 VDC @ 217 mA average with 338 mA maximum on transmit; 215 mA continuous receive, 17 mA standby PCI: 5VDC @ 247 mA average with 368 mA maximum on transmit; 245 mA continuous receive, 47 mA standby
Status lights	1 (Reports: Link, Power)
Regulatory Approval.....	US - FCC part 15B and 15C, IC RSS-210 ETSI - FCC part 15B, CE, ETS 300 328, ETS 300 826, C-Tick (Australia)
Physical Specification.....	PC Card: PCMCIA Type II PC Card PCI: 32-bit, 5V Key, Full Plug-N-Play
Antenna(s).....	Integrated: Printed dual diversity External: 2.2dBi dipole; additional options for specific installation needs

1-12 500 WATTS POWER SUPPLY

The 500 Watts power supply combine high performance midrange power with high power density (4.4 watts/in³), active Power Factor Correction (PFC) and high reliability to meet the requirements of commercial and industrial systems. Providing tightly regulated DC power, the power supply delivers full output performance with only 300 Linear Feet per Minute (LFM) forced air-cooling by utilizing a factory installed fan. Other features include remote sense, power fail, logic level inhibit, DC power good. Main channel current sharing is provided for redundant applications. The power supply is approved to the latest international regulatory standards, and displays the CE Mark.



Figure 1-15. 500 Watts Power Supply

a. Features

- Power Factor Correction (PFC) Meets EN61000-3-2
- Fully Regulated Outputs
- Remote Sense
- Current Share, Power Fail, and Power Good Signals
- Overtemperature, Overvoltage, and Overcurrent Protected
- Available with Metric or SAE Mountings
- Input Transient & ESD Compliance to EN61000-4-2/-3/-4/-5
- Fan Output Voltage and Optional Fan
- Optional Isolation Diodes for Parallel or Redundant Operation

Model MicroCEM

1-13 MicroCEM SPECIFICATIONS

a. Analyzer

Power	Universal Power Supply 85 – 264 VAC, 50 – 60 Hz, \pm 10%, 500 Watts Maximum at Start Up. 250 Watts Nominal
Microprocessor	Intel Pentium processor, 266MHz, 64MB RAM, PC/104 architecture, Windows NT embedded Platform
Pocket PC.....	133MHz, 21 bit Hitachi SH3 processor, 32MB RAM 16MB ROM, 240 X 320 pixels LCD, Riuch color, backlit, Wireless LAN optional
Detectors//Number	NDIR, Paramagnetic, Electrochemical, Chemiluminescence// Up to three in one analyzer
Mounting.....	Wall Mount
Area Classification.....	General Purpose / NEMA 4X (IP65) Fiberglass Enclosure
Ambient Range	
Temperature	-30° to 50° Celsius.
Relative Humidity.....	5 to 99%
Inputs/Outputs	
Digital.....	RS-485 Serial Port. (Multi-Drop Network) RS-232 Serial Port. LAN, Ethernet 10/100-BaseT Modem.
Connectivity Protocols	HTML (Web Browser) – Status, file transfer Modem/Webbrowser TCP/IP..Modbus (In Process) Foundation Fieldbus (In Process)
Analog Current Outputs.....	3 Isolated 4-20 mA DC, 500 ohms Max Load (O ₂ , CO, NO _x) Analog Inputs:MW, Fuel Flow Digital Outputs Trouble Alarm, Sample Pump on/off, Drain Pump on/off, Purge on/off, Calibrate on/off – 110VAC @ 1amp Dry Contact O ₂ Limit Exceed, CO Limit Exceed, NO _x Limit Exceed, O ₂ Low Range, CO Low Range, NO _x Low Range. - TTL: 5 VDC Max Current 20 mA
Digital Inputs	Process on/off, Initiate Auto Calibration
Instrument Weight	62 lbs. Typical
Dimensions.....	24" x 20" x 12" (HxWxD)
Ranges	O ₂ : 0 –25% CO: 0 –100ppm Selectable to 1000ppm NO _x : 0 – 10ppm Selectable to 1000ppm
Sample Temperature.....	0° C to 55° C
Sample Flow Rate5 to 1.5 liters/min
Warm Up Time	Max 25 minutes @ low ambient temperatures

	Paramagnetic O₂	Electro- Chemical O₂	NDIR CO	Chemiluminescence NO_x
Linearity	< ± 1%	< ± 1%	< ± 1%	< ± 1% ¹
Zero Drift	< ± 1% /day	< ± 1% /day	< ± 1% /day	< ± 1% /day ¹
Span Drift	< ± 1% /day	< ± 1% /day	< ± 1% /day	< ± 1% /day ¹
Repeatability	< ± 1%	< ± 1%	< ± 1%	< ± 1%/day ¹
Response Time (t90)	10< ± t90< ± 15	10< ± t90< ± 15	15s< ± t90< ± 20s	15s< ± t90< ± 20s
Influence of Ambient Temperature (-20°C to 45°C)				
On Zero	< ± 1%	< ± 1%	< ± 2%	< ± 2%
On Span	< ± 1%	< ± 1%	< ± 2%	< ± 2%

b. Probe/Sample Handling

Power Universal Power Supply 85 – 264 VAC, 50 – 60 Hz, ± 10%
500 Watts Maximum at Start Up. 250 Watts Nominal

Mounting Wall Mount

Area Classification General Purpose / NEMA 4X (IP65) Fiberglass Enclosure

Ambient Range

 Temperature -30° to 50° Celsius

 Relative Humidity 5 to 99%

Instrument Weight 75 lbs. Typical

Dimensions 24" x 24" x 12" (HxWxD)

Stack Sample Moisture Up to 25%

Sample Cooler Thermo Electric dual pass Chiller.
Permeation Tube (-30° C) dewpoint.
Customer instrument air required @ 5 L/M, -40° C dewpoint

Max. Stack Temperature 500° F (Higher temperatures available by utilizing elongated spools)

Stack Pressure -5 to 15 inches H₂O

Sample Flow Rate 1 L/min from sample handling enclosure to Analysis enclosure

Response Time (Max distance between Analysis Enclosure and Sample Conditioning/Probe)
Enclosure is 300'. (Response time is 20 seconds/100' w/1/4" tubing).

Probe Length 48" length 316 SS Probe with .5 micron sintered filter. (Customer to cut to length in field.)

Mounting Flange Optional 4" 150#

Sample Pump 316 SS diaphragm type

Instrument Air Requirements Instrument grade air required. 15 SCFM @ 60 -100 PSIG (30 seconds 2 times per day). (Pressure Regulation by Customer.)

¹ 0-10ppm NO_x range is <± 3%.

SECTION 2 INSTALLATION

WARNING

**ELECTRICAL SHOCK HAZARD
POSSIBLE EXPLOSION HAZARD**

Do not open while energized. Do not operate without doors and covers secure. Installation requires access to live parts which can cause death or serious injury.

DANGER

ELECTRICAL SHOCK HAZARD

Installation and servicing of this device requires access to components that may present electrical shock and/or mechanical hazards. Refer installation and servicing to qualified service personnel.

CAUTION

CODE COMPLIANCE

Installation of this device must be made in accordance with all applicable national and/or local codes. See specific references on the installation drawing located in the rear of this manual.

CAUTION

PRESSURIZED GAS

This unit requires periodic calibration with a known standard gas. It also may utilize a pressurized carrier gas, such as helium, hydrogen, or nitrogen. See General Precautions for Handling and Storing High Pressure Gas Cylinders, page P-5.

2-1 OVERVIEW

a. Limitations

Ambient Temperature: -30° to 50° Celsius (-4° to 122° F)

Relative Humidity: 5% to 99%

b. Mounting Options

Although the MicroCEM is enclosed in an environmentally sealed enclosure, it should be protected from direct sunlight. In areas subjected to harsh winter climates, protection should be provided from sun, rain and snow. A corrugated awning or other suitable means can be provided to meet these conditions.

2-2 LOCATION

The MicroCEM is designed to be installed in an outdoor environmental location. It is recommended that the analyzer be located out of direct sunlight and direct rain/snow to the extent possible.

The MicroCEM analysis enclosure should be installed as near as possible to the probe/sample handling enclosure, in order to avoid low response time caused by long sample gas lines.

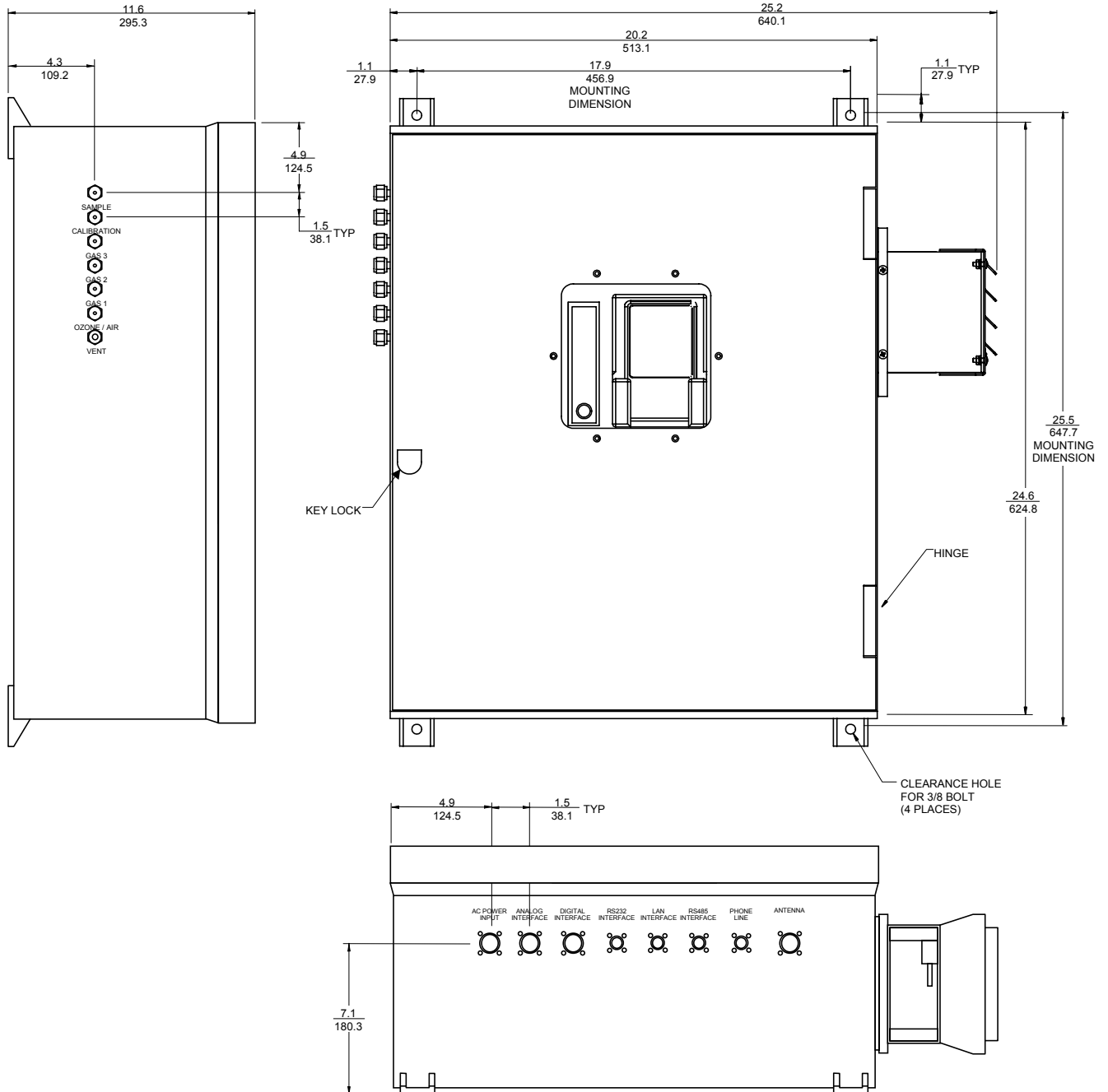

Figure 2-1. MicroCEM Outline and Mounting Dimensions

Model MicroCEM

2-3 GASES

NOTE

For external gas lines, the use of new tubing throughout is strongly recommended. The preferred type is teflon or stainless steel, sealed at both ends.

a. Connection

Besides sample gas, the MicroCEM requires other gases for operation. In most cases, one or more Calibration Standards must be provided. These should be cylinders of gas which closely resemble the expected sample, both in species and concentrations. These calibration gases are normally introduced into the system as an input to the Sample Conditioning Plate Option or sample conditioning may be provided by others.

Each gas cylinder should be equipped with a clean, hydrocarbon free two-stage pressure regulator with indicating gauges of approximately 0 to 3000 psig (0 to 20.7 bar) for cylinder pressure and 0 to 100 psig (0 to 6.7 bar) for delivery pressure. Pressure regulators should have a metallic as opposed to elastomeric diaphragm, and provide for ¼ inch compression fitting outlet and should be LOX clean.

NOTE

All connections specified in the Installation Drawing, in conjunction with the Application Data Sheet, should be made.

b. Conditioning

All gases must be supplied to the analyzer as conditioned gases! When the

system is used with corrosive gases, it must be verified that there are no gas components which may damage the gas path components.

The gas conditioning must meet the following conditions:

- Free of condensable constituents
- Free of dust above 2 µm
- Free of aggressive constituents which may damage the gas paths
- Temperature and pressure in accordance with the specifications

When analyzing vapors, the dewpoint of the sample gas must be at least 10 °C below the ambient temperature in order to avoid the precipitation of condensate in the gas paths.

An optional barometric pressure compensation feature can be supplied. This requires a pressure sensor with a range of 800 – 1,100 hPa. The concentration values computer by the detectors will then be corrected to eliminate erroneous measurements due to changes in barometric pressure.

The gas flow rate must be in the range of 0.2 l/min to a maximum of 1.5 l/min. A constant flow rate of 1 l/min is recommended.

NOTE

The maximum gas flow rate for paramagnetic oxygen detectors is 1.0 l/min!



Figure 2-2. MicroCEM Gas Connections

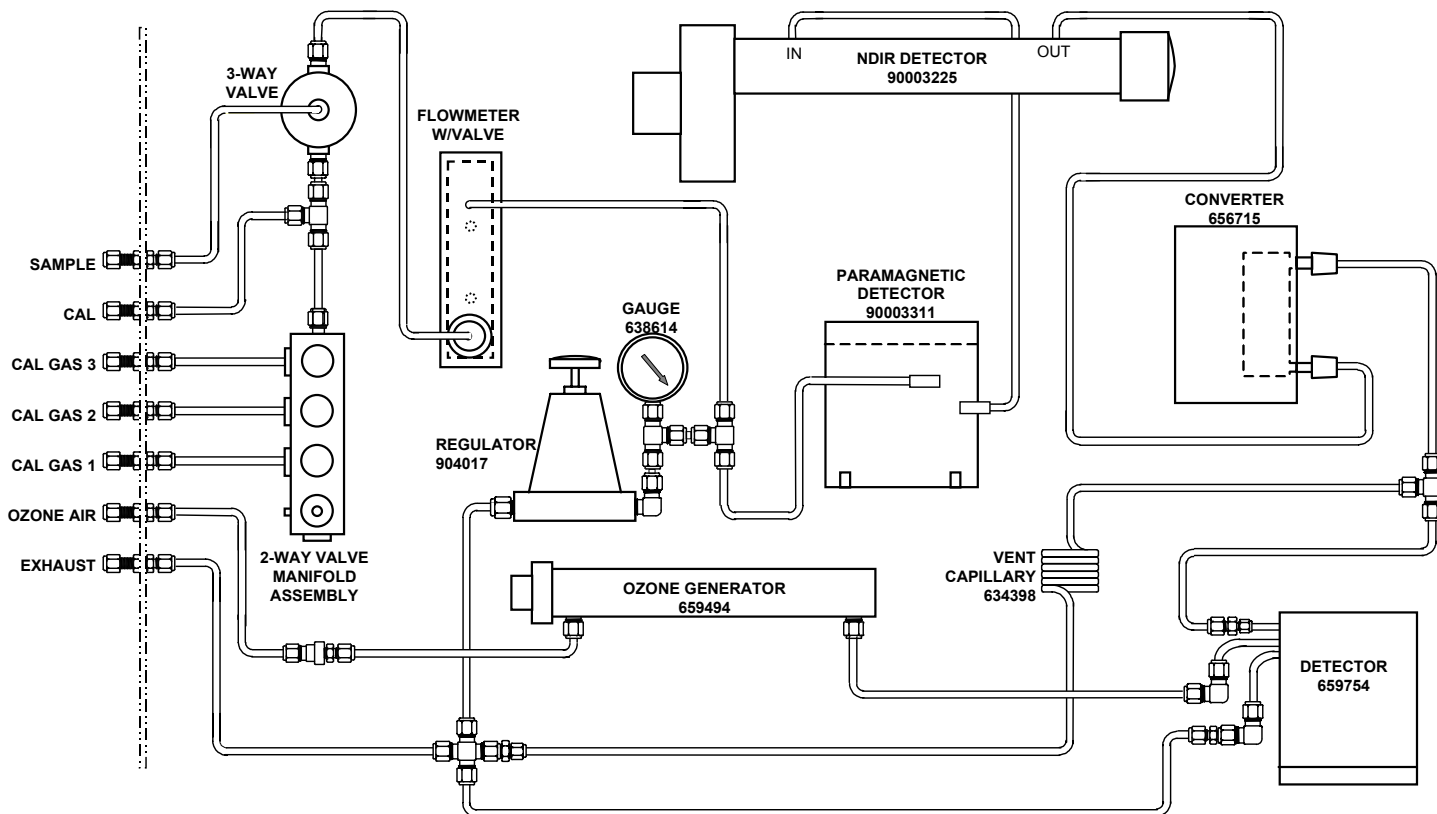

Figure 2-3. MicroCEM Flow Diagram

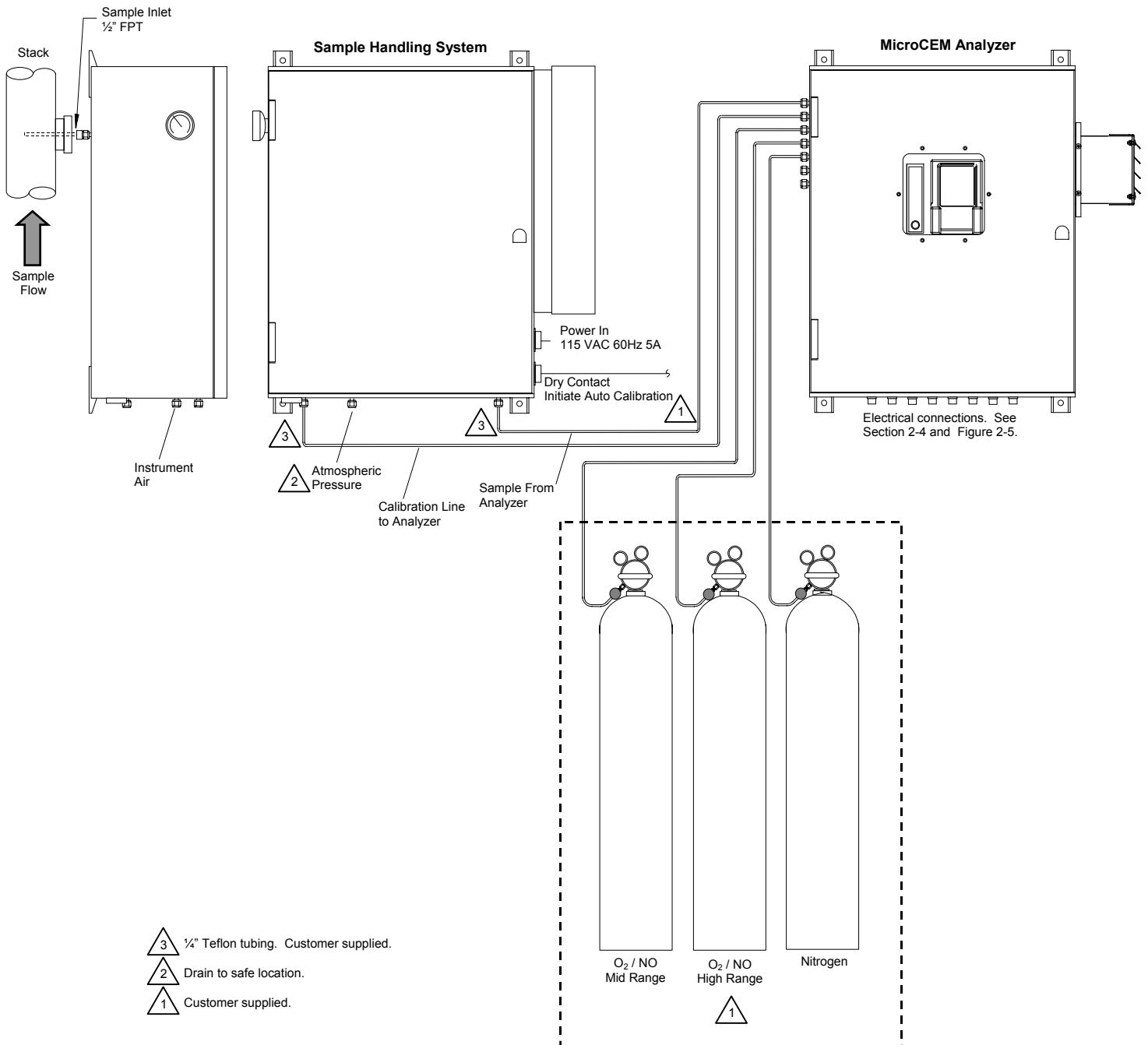

Figure 2-4. MicroCEM Installation and Test Setup Configuration

2-4 ELECTRICAL CONNECTIONS

NOTE

The enclosure is a NEMA 4. All entry locations must be sealed.

Connect all required signal cables to the connections at the bottom of the MicroCEM. The cable locations are indicated on the inside bottom cover of the MicroCEM box. The ac-

tual electrical connections will be specified in the Application Data package. All connections are not necessary for every application.

Cable length for these signals should not exceed 3,000 feet (914 meters), to avoid excessive capacitance and corresponding signal distortion.

All electrical connections are made through the bottom of the MicroCEM enclosure using circular connectors.

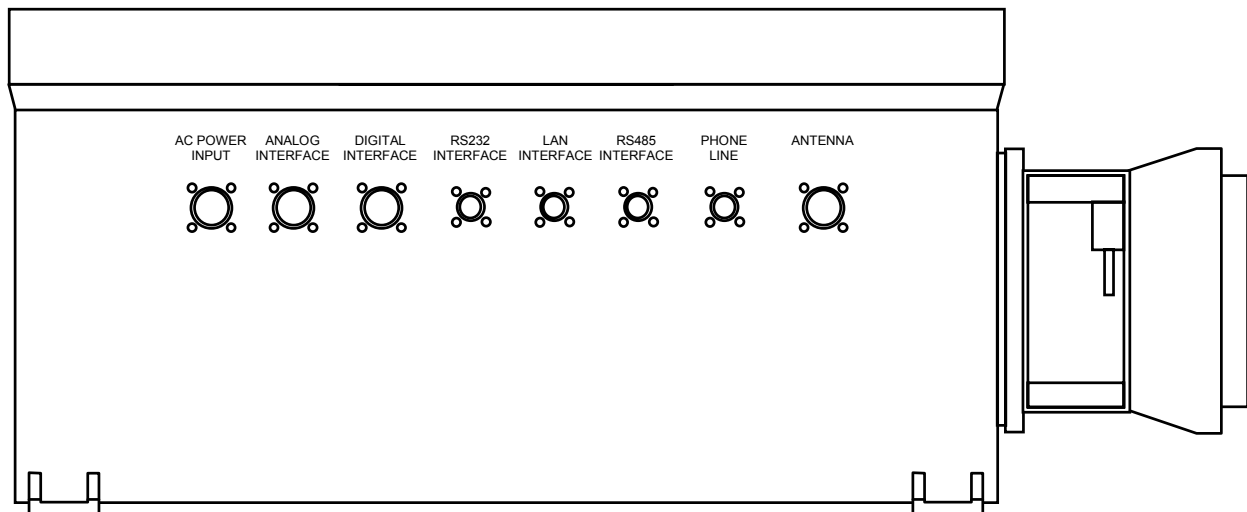

AC POWER INPUT – J1
ANALOG INTERFACE – J2
DIGITAL INTERFACE – J3
RS232 INTERFACE – J4

LAN INTERFACE – J5
RS485 INTERFACE – J6
PHONE LINE – J7
ANTENNA – J8

Figure 2-5. MicroCEM Electrical Connections

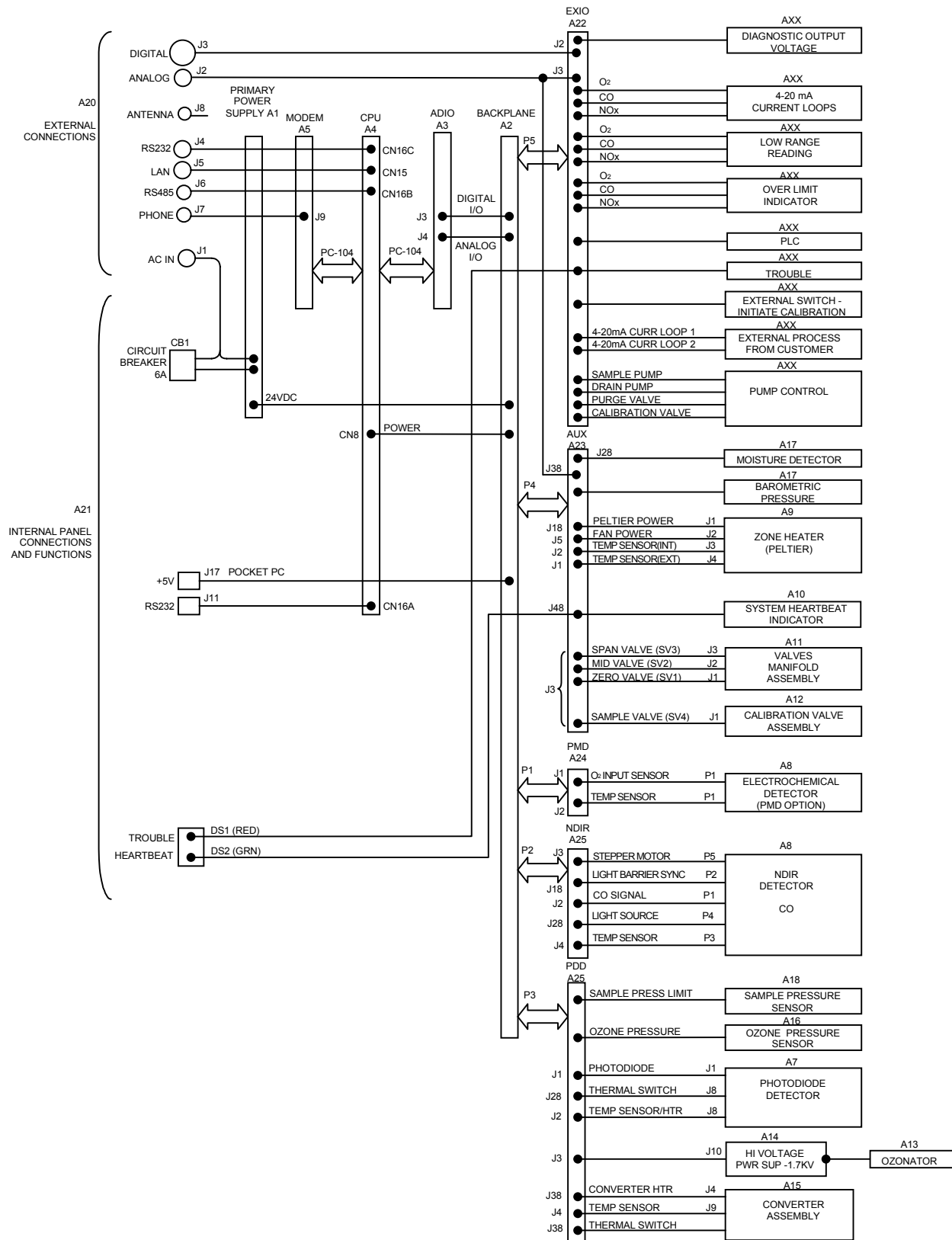

Figure 2-6. MicroCEM Wiring Diagram

a. AC Power

Connect AC power through a 10A circuit breaker that is to be located close to the MicroCEM. The circuit breaker will provide over current protection as well as a means of disconnecting the power.

Maximum power requirements will be 380 watts, with most applications requiring less than this amount.

b. Circular Connector Assembly Instructions

Wire Stripping

Strip insulation from end of wire to be crimped. Do not cut or damage wire strands. Refer to table for proper stripping dimensions.

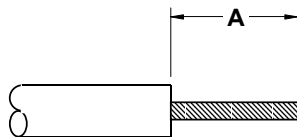

Wire Size	Dim. A
22O or 22M*	.125 (3.18)
20	.188 (4.77)
16	.188 (4.77)
12	.188 (4.77)
*Inactive. Not recommended for new design, replacement only.	

Contact Crimping

1. Insert stripped wire into contact crimp pot. Wire must be visible through inspection hole.



2. Using correct crimp tool and locator, cycle the tool once to be sure the indentors are open. Insert contact and wire into locator. Squeeze tool handles firmly and completely to insure a proper crimp. The tool will not release unless the crimp indentors in the tool head have been fully actuated.

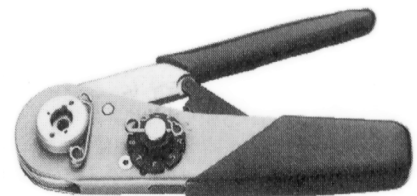
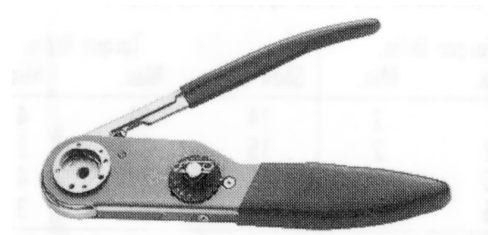

3. Release crimped contact and wire from tool. Be certain the wire is visible through inspection hole in contact.



Contact Insertion

1. Remove hardware from plug or receptacle and slip over wire bundle in proper order for reassembly.



2. Using proper plastic or metal insertion tool for corresponding contact, position wire in tip of the tool so that the tool tip butts up against the contact shoulder.

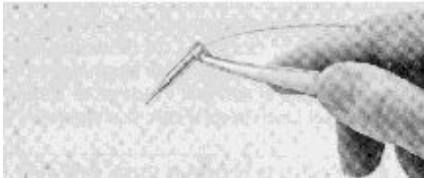

3. Press tool against contact shoulder and, with firm and even pressure, insert wired contact and tool tip into center contact cavity. A slight click may be heard as metal retaining tines snap into place behind contact shoulder.
4. Remove tool and pull back lightly on wire to make sure contact is properly seated. Repeat operation with remainder of contacts to be inserted, beginning with the center cavity and working outward in alternating rows.

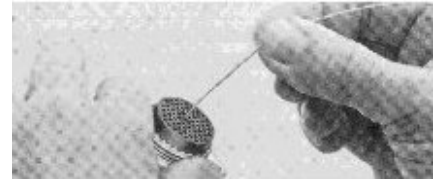

5. After all contacts are inserted, fill any empty cavities with wire sealing plugs. Reassemble plug or receptacle hardware.

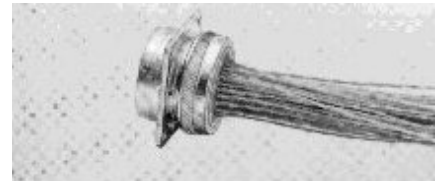

Contact Extraction

1. Remove hardware from plug or receptacle and slide hardware back along wire bundle.

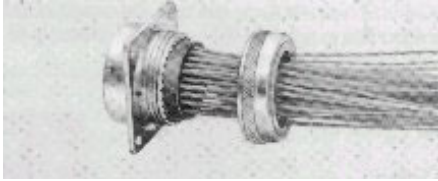

2. Using plastic or metal extraction tool with proper color code corresponding to contact size, place wire in tool.

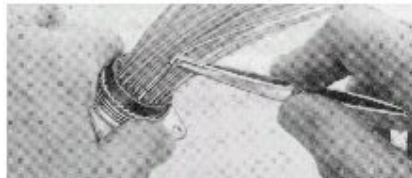

3. Insert tool into contact cavity until tool tip bottoms against the contact shoulder, expanding clip retaining tines.



4. Hold wire firmly in tool and extract wired contact and tool. Repeat operation for all contacts to be extracted.

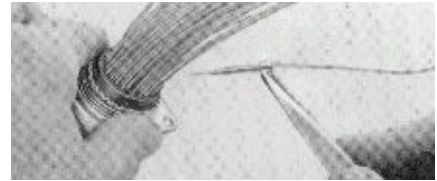

5. Fill any empty wire cavities with wire sealing plugs.



6. Reassembly plug or receptacle.



c. Interface Connections

Connection	Designator	Shell Size	No. Contacts	AWG	Table
AC Power	J1	12	3	16	Table 2-2
Analog Interface	J2	12	22	26, 24, 22	Table 2-3
Digital Interface	J3	14	37	26, 24, 22	Table 2-4
RS232	J4	10	13	28, 26, 24	Table 2-5
LAN Interface	J5	8	6	28, 26, 24, 22	Table 2-7
RS485	J6	8	3	24, 22, 20	Table 2-6
Phone Line (Modem)	J7	8	3	24, 22, 20	Table 2-8
Antenna (Peltier Power)	J8	16	3	14, 12	Table 2-9

Table 2-1. Interface Connections

SIGNAL NAME	DEFINITION	PIN
L1	85-264 VAC, 47-440 Hz	A
L2		C
GND	AC Ground	B

Table 2-2. AC Power Connection Terminal Assignments

SIGNAL NAME	DEFINITION	PIN
O ₂ CL+	O ₂ Reading, 4-20 mA Output	1
O ₂ CL-		2
COCL+	CO Reading, 4-20 mA Output	3
COCL-		4
NO _x +	NO _x Reading, 4-20 mA Output	5
NO _x -		6
EXP1CL+	External process No. 1, Current Loop input, 4-20 mA	7
EXP1CL-		8
EXP2CL+	External process No. 2, Current Loop input, 4-20 mA	9
EXP2CL-		10
BAROP+	Barometric pressure Compensator 0-10V input	11
BAROP-		12

Table 2-3. Analog Output Terminal Assignments

SIGNAL NAME	DEFINITION	PIN
SPUMPNO	Sample Pump Control, Dry contact, 110V 1A Rating	1
SPUMPC		2
SPUMPNC		3
DPUMPNO	Drain Pump Control, Dry contact, 110V 1A Rating	4
DPUMPC		5
DPUMPNC		6
PURGNO	Purge Valve Control, Dry contact, 110V 1A Rating	7
PURGC		8
PURGNC		9
CALNO	Calibration Valve Control, Dry contact, 110V 1A Rating	10
CALC		11
CALNC		12
TRBLNO	Trouble Indicator, Dry contact, 110V 1A Rating	13
TRBLC		14
TRBLNC		15
O2LR+	O2 Low Reading Digital output (0=LR)	16
O2LR-		17
COLR+	CO Low Reading Digital output (0=LR)	18
COLR-		19
NOxLR+	NOx Low Reading Digital output (0=LR)	20
NOxLR-		21
EXTDIG1+	Digital Input from External process	22
EXTDIG1-		23
INCAL+	Initiate Calibration Switch Input	24
INCAL-		25
O2OL+	O2 Over Limit Indicator	26
O2OL-		27
COOL+	CO Over Limit Indicator	28
COOL-		29
NOxOL+	NOx Over Limit Indicator	30
NOxOL-		31
	Not Used	32-37

Table 2-4. Digital Output Terminal Assignments

SIGNAL NAME	DEFINITION	PIN
DCD (pin 1)	Data Carrier Detect Input	1
DSR (pin 6)	Data Set Ready Input	2
RxD (pin 2)	Receive Data Input	3
RTS (pin 7)	Request to Send Output	4
TxD (pin 3)	Transmit Data Output	5
CTS (pin 8)	Clear To Send Input	6
DTR (pin 4)	Data Terminal Ready Output	7
RI (pin 9)	Ring Indicator Input	8
GND (pin 5)	Signal Ground	9
	Not Used	10-13

Table 2-5. RS-232 Interface Terminal Assignments

SIGNAL NAME	DEFINITION	PIN
TxD/RxD+ (pin 2)	Bi-directional Data	A
TxD/RxD- (pin 7)		B
GND (pin 3)	Ground	C

Table 2-6. RS-485 Terminal Assignments

SIGNAL NAME	DEFINITION	PIN
TxD+ (pin 1)	Transmit Data	1
TxD- (pin 2)		2
RxD+ (pin 3)	Receive Data	3
RxD- (Pin 6)		4
	Not Used	5-6

Table 2-7. LAN Interface Terminal Assignments

SIGNAL NAME	DEFINITION	PIN
TIP (pin T)	Modem Interface to Phone Line	A
RING (pin R)		B
	Not Used	C

Table 2-8. Phone Line (Modem) Terminal Assignments

SIGNAL NAME	DEFINITION	PIN
Vbb	+24VDC	A
Vbb_rtn	+24V Return	B
Gnd	GND	C

Table 2-9. Antenna (Peltier Power) Connection Terminal Assignments

2-5 ANALYTICAL LEAK CHECK

If explosive or hazardous gas samples are being measured with the MicroCEM, it is recommended that gas line fittings and components be thoroughly leak-checked prior to initial application of electrical power, bimonthly intervals thereafter, and after any maintenance which involves breaking the integrity of the sample containment system.

a. Flow Indicator Method

Supply air or inert gas such as nitrogen, at 10 psig (689 hPa), to the analyzer through a flow indicator with a range of 0 to 250 cc/min. Install a shut-off valve at the sample gas outlet. Set the flow rate to 125 cc/min.

Close the outlet shut-off valve and notice that the flow reading drops to zero. If the flow reading does not drop to zero, the system is leaking and must be corrected before the introduction of any flammable sample gas or application of power.

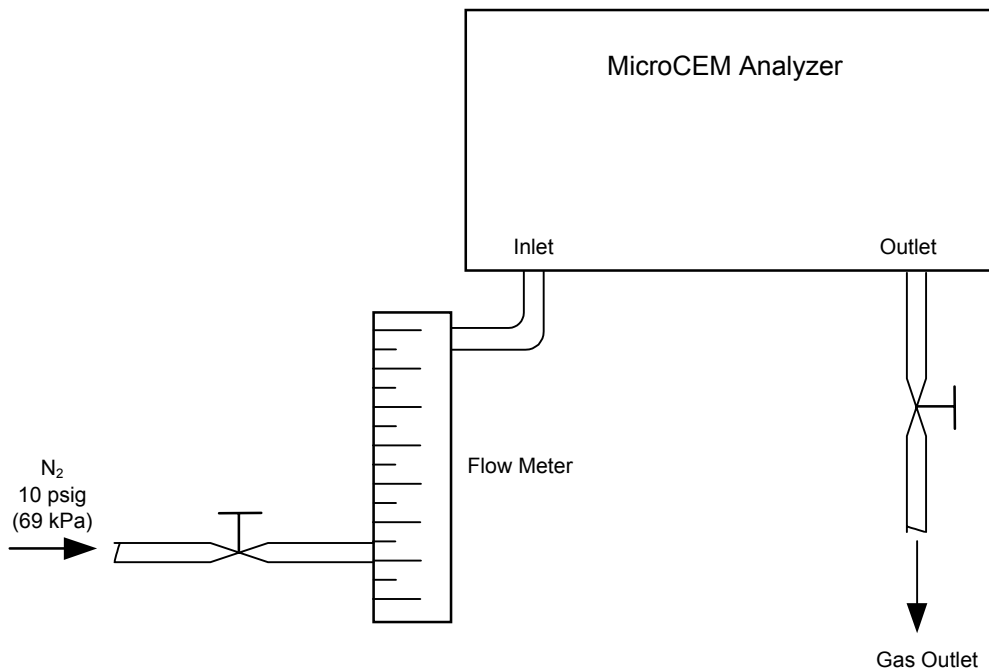

Figure 2-7. Leak Test Flow Method

b. Manometer Method

Install a water-filled U-tube manometer at the sample gas outlet. Install a shut-off valve at the sample gas inlet. Admit air or inert gas to the inlet shut-off valve until the analyzer is pressurized to approximately 50 hPa. The water column will be about 500 mm.

Close the inlet shut-off valve and, following a brief period for pressure equilibrium, verify that the height of the water column does not drop over a period of about 5 minutes. If the water column height drops, the system is leaking and must be corrected before the introduction of any flammable sample gas or application of power.



Figure 2-8. Leak Test Manometer Method

SECTION 3 OPERATION

CAUTION

Do not operate or service this instrument before reading and understanding this instruction manual and receiving appropriate training.

Refer to installation drawing supplied with the application data package.

3-1 STARTUP PROCEDURE

Once the MicroCEM has been correctly assembled and installed in accordance with the instructions in Section 2, the analyzer is ready for operation.

Before operating the system, verify that the leak checks have been performed and that the sample handling unit is performing correctly.

Apply power to the system and verify that sample gas is flowing.

NOTE

A warm-up time of from 15 to 50 minutes is required depending on the installed detector(s).

Analyzer operation can be confirmed on the screen of the pocket PC through the glass window on the door. Upon power up, the analyzer will perform a self-test routine. This test will last approximately 60 seconds.

3-2 POCKET PC USER INTERFACE

The MicroCEM User Interface runs on a Pocket-PC with Windows CE operating system. It communicates with the MicroCEM via serial communication port. All input to the Pocket-PC is done using a pointing device that comes with the Pocket-PC.

a. Connecting Pocket PC to MicroCEM

1. Open MicroCEM door. Refer to Figure 3-2.
2. Plug RS232 plug into adapter located on front panel.
3. Plug power supply cable into 5V adapter
4. Turn Pocket PC on
5. In order to assure no other windows are open press the reset button. Reset button is located on the back of the pocket PC.
6. Using the MicroCEM menu click on "programs"
7. Click on "Connection" icon
8. Click on "uCEM" icon.
9. Go to tools menu and click on MicroCEM .
10. Unit will display data in 3 to 5 seconds.



Figure 3-1. Pocket PC



Figure 3-2. MicroCEM Front Panel

Model MicroCEM

b. Main Display

The MicroCEM Main Display (Figure 3-3) provides the status of the three emissions channels. The status includes the current reading (updated approximately every 2 seconds), the

last 1-minute average, and the last 15-minute average. The status column (Sts) indicates the status of the measurement and can be any of the values in listed in Table 3-1. ("Status" shown in order of precedence. Maintenance mode status takes highest precedence.)

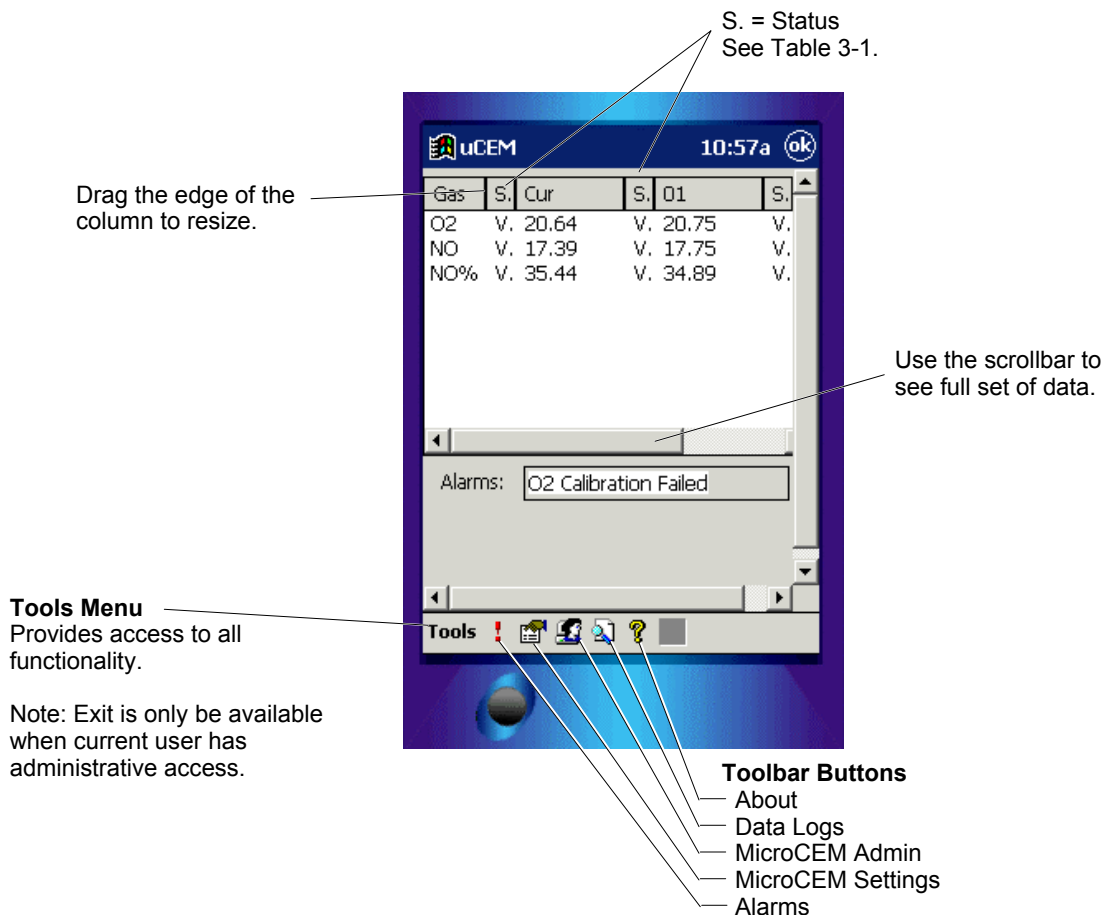

Figure 3-3. MicroCEM Pocket PC Display (Main Display Shown)

STATUS	DESCRIPTION
M	Indicates that maintenance mode is active.
C	Calibration in process
I	Invalid Reading. Indicates that the reading is invalid due to calibration failure or sensor failure.
V	Valid Reading
P	Customer Process Off Line (Dry contact by customer)
O	MicroCEM System Off

Table 3-1. Status Values

c. MicroCEM Menu

Clicking on the Tools text in the lower left corner of the display activates the MicroCEM menu. From this menu, all of the MicroCEM user-interface functions can be accessed.

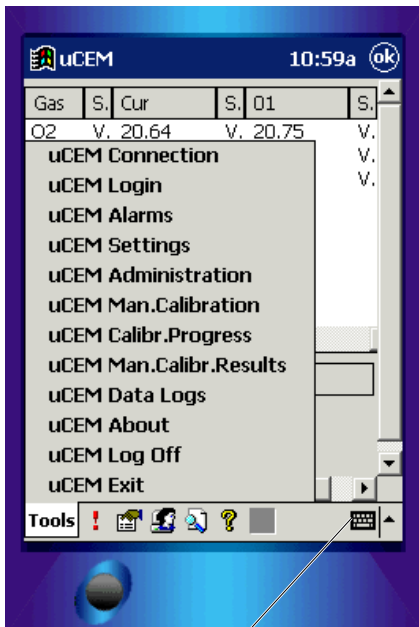

On-screen keyboard is available at any time by clicking on the keyboard button.

Figure 3-4. MicroCEM Menu

d. MicroCEM Alarms

The MicroCEM Alarms dialog shows all the current alarms. A current alarm is one with an Active status of 1 (active) or an Acknowledged state of 0 (not acknowledged). If the Show Historical Alarms checkbox is checked, all non-current alarms are also shown (non-active acknowledged alarms). Up to 100 alarms will be shown. To see more than the last 100 alarms, the web based MicroCEM interface must be used. If one or more alarms are current, the most recent of them will be displayed on the main display. If more than one alarm is current (“more”) will be displayed after the name of the most recent alarm on the main window to indicate that more than one alarm is active. Horizontal scroll bar is used to see Date and Time of the Alarms.

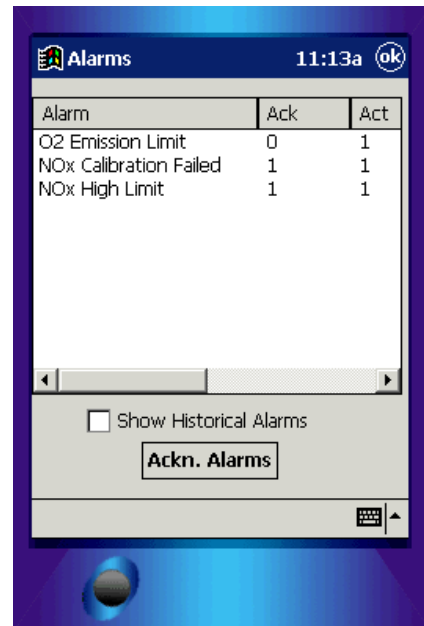

Figure 3-5. Pocket PC Alarms Screen

Alarms with a critical level will cause the System trouble output to become active when the alarm is active. When all active critical alarms are acknowledged, the System trouble output will become inactive.

Model MicroCEM

ALARM NAME	LEVEL	DESCRIPTION
O2 Calibration Failed	Critical	O2 Calibration Failed to meet the maximum Drift requirements
CO Calibration Failed	Critical	CO Calibration Failed to meet the maximum Drift requirements
NOx Calibration Failed	Critical	NOx Calibration Failed to meet the maximum Drift requirements
O2 High Limit	Critical	O2 Sensor reading is above the minimal acceptable limit
O2 Low Limit	Critical	O2 Sensor reading is below the minimal acceptable limit
CO High Limit	Critical	CO Sensor reading is above the minimal acceptable limit
CO Low Limit	Critical	CO Sensor reading is below the minimal acceptable limit
NOx High Limit	Critical	NOx Sensor reading is above the minimal acceptable limit
NOx Low Limit	Critical	NOx Sensor reading is below the minimal acceptable limit
24V Over Max	Critical	24V diagnostic input exceeds the specified maximum
24 Low Min	Critical	24V diagnostic input is below the specified minimum
O2 Emission Limit	Warning	O2 reading is over the specified Limit
CO Emission Limit	Warning	CO reading is over the specified Limit
NOx Emission Limit	Warning	NOx reading is over the specified Limit
Converter Over Temp	Critical	Converter temperature reading exceeds the specified maximum
Converter Low Temp	Critical	Converter temperature reading is below the specified minimum
Zone Over Temp	Critical	Zone temperature reading exceeds the specified maximum
Zone Low Temp	Critical	Zone temperature reading is below the specified minimum
PDT Over Temp	Critical	Peltier Cooler (PDT) temperature reading exceeds the specified maximum
PDT Low Temp	Critical	Peltier Cooler (PDT) temperature reading is below the specified minimum
PMT Over Temp	Critical	PDD Chamber temperature reading exceeds the specified maximum
PMT Low Temp	Critical	PDD Chamber temperature reading is below the specified minimum
Warm-up Time Limit	Critical	System Warm-up process exceeded the specified time limit

Table 3-2. Alarm Summary

e. MicroCEM Login

The login dialog appears (Figure 3-6) when first requesting the MicroCEM Settings or MicroCEM Admin. If a valid user name and password are entered, the user logging in will have permission to use the MicroCEM Settings and/or the MicroCEM Administration (Refer to the User Settings page of the MicroCEM Settings dialog). After logging in the first time, it is not required again until the user logs out, or is logged out automatically because of a period of inactivity (Refer to the Auto Logout page of the MicroCEM Administration dialog).



Figure 3-6. MicroCEM Login

f. MicroCEM Login-Current User Indication

When a user is logged in, the MicroCEM main display will indicate the user name of the logged in user as shown in Figure 3-7. When the user logs off, the current user and the Logoff button will not be shown.

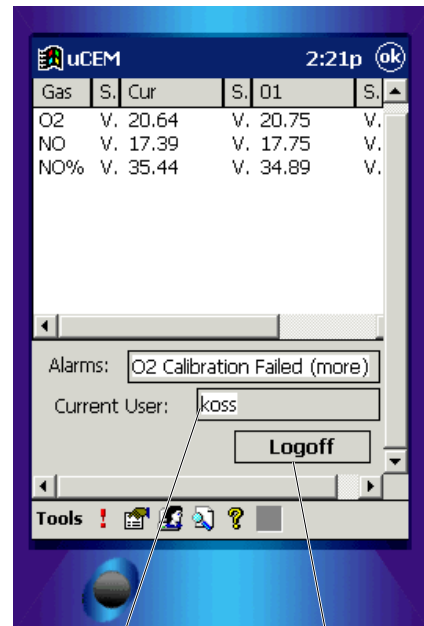

Current User

Logoff Button

Figure 3-7. Current User Indication

Model MicroCEM

3-3 MicroCEM SETTINGS

The MicroCEM Settings dialog is only available to users with MicroCEM Settings permission. If a user is not currently logged in, the login dialog will be displayed. If the current user doesn't have MicroCEM Settings permission, a message will be displayed which reads "Permission denied". When the MicroCEM Settings are invoked from the Tools menu or the MicroCEM Settings button, the MicroCEM Settings tabbed dialog is displayed. The Range page (tab) is displayed initially.

a. Range

The Range Settings page is used to set the range of the Emissions analog outputs. The outputs support dual range mode. When the emission is below the Range 1 value, the output switches to Range 1 mode and the Range 1 value becomes the full-scale value of the output. The range indication digital output will change to the Range 1 state. When the emission is above the Range 1 value, the output switches to Range 2 mode and the Range 2 value becomes the full-scale value of the output. The range indication digital output will change to the Range 2 state. The Range 2 settings cannot be changed and are factory-set.

NOTE

If only one range is needed, set the Range 1 values to the range 2 value. This will disable the dual range feature.

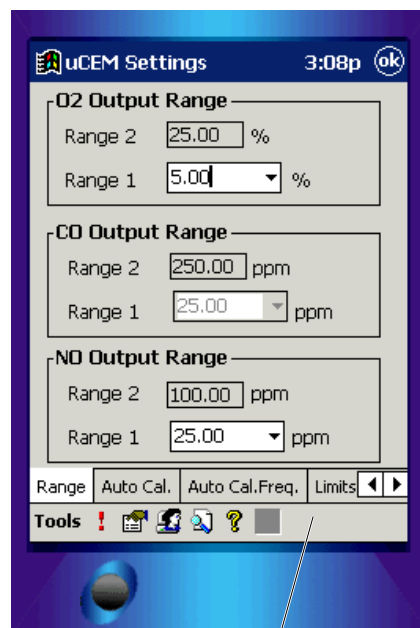

Tabs allow selection of the MicroCEM Settings pages

Figure 3-8. Range Settings

b. Auto Calibration

The Auto-Calibration settings are set on the Auto-Calibration page of the Micro-CEM settings. If auto calibration is turned to the on position, then the user can select time and/or frequency of the auto calibration in the Auto Calibration Frequency tab (Section 3-3c).

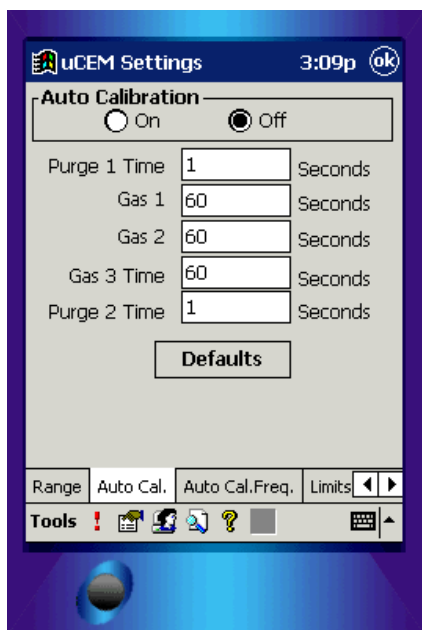

Figure 3-9. Auto Calibration Settings

c. Auto Calibration Time and Frequency

The Auto-Calibration Time and Frequency tab allows specifying time and frequency of the auto-calibration. Time field requires military time format.

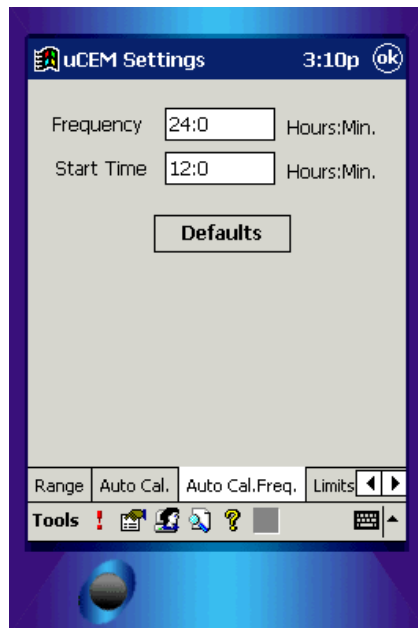

Figure 3-10. Auto Calibration Time and Frequency

Model MicroCEM

d. Manual Calibration

A dry-run Calibration may be initiated from the Manual Calibration page of the MicroCEM Settings. The results of the calibration will not be applied and only provide a dry run of the calibration. If desired a partial calibration may be invoked for one or more of the emission types. While the manual calibration is in process, a calibration progress dialog will be displayed as shown in Figure 3-26. When the manual calibration is completed, the results are displayed in the Manual Calibration Results dialog as shown in Figure 3-12. If the Local Calibration checkbox is checked, the Local Calibration valve will be used during the calibration rather than the probe Calibration valve.

NOTE

“Start Autocalibration now” will invoke a real calibration and will apply new correction factor results when done.

Item	Expect.	Act.
O2 Zero	21.00	4.00
O2 MidSpan	33.00	11.00
O2 Span	6.00	5.00
CO Zero	8.00	27.00
CO MidSpan	6.00	10.00
CO Span	1.00	20.00
NOx Zero	20.00	14.00
NOx MidSpan	6.00	16.00
NOx Span	9.00	0.00

Figure 3-12. Manual Calibration Results

Manual Calibration 3:11p ok

Manual Calibrate All

Start Auto Cal Now

----- Partial Calibration -----

O2 Purge

CO Zero

NOx MidSpan

 Span

Local Calibration

OK

Figure 3-11. Manual Calibration

e. Limits

The emission limits alarms can be set on the Limits page of the MicroCEM Settings. When a measured emission exceeds its limit, the emission will have a limit-exceeded status. This is indicated on the main display and on the Data-Logs display. It is also indicated in the limit exceeded digital output.

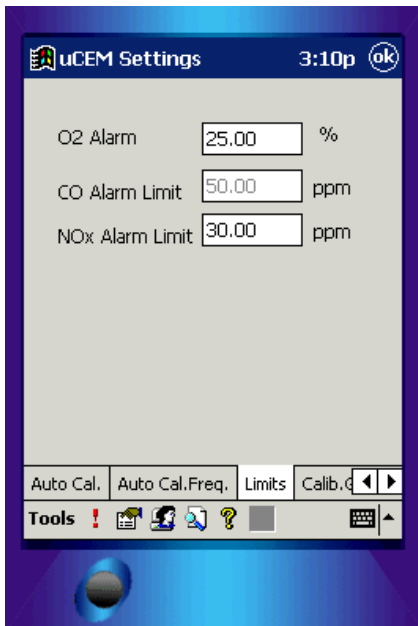

Figure 3-13. Limit Settings

f. Calibration Gas

The Calibration Gas emissions quantities and Gas Bottle allocation may be set on the Calibration Gas page of the MicroCEM Settings. This should be set whenever a Calibration Gas container is replaced.

Place the span gas value of the particular gas cylinder in the span column. 1 mid calibration gas can also be hooked up the MicroCEM. Insert its span gas value in the mid span boxes. If a dual range is used use the Mid Span column.

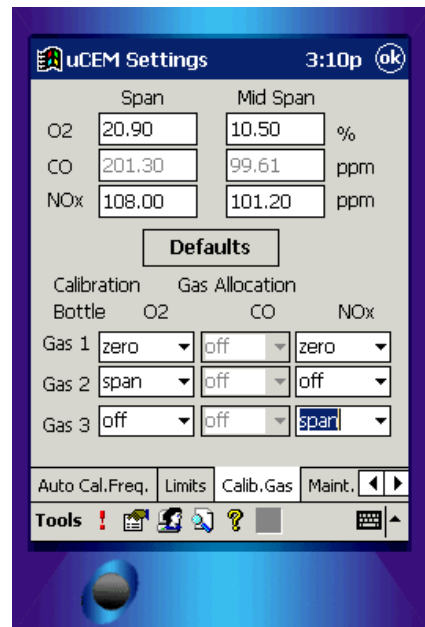

Figure 3-14. Calibration Gas Settings

Model MicroCEM

g. Maintenance Mode

Maintenance mode may be selected for any of the emission types on the Maintenance Mode page of the MicroCEM Settings.

Choosing maintenance mode will invoke an "M" flag" onto the data. Customer can perform routine maintenance while in this setting

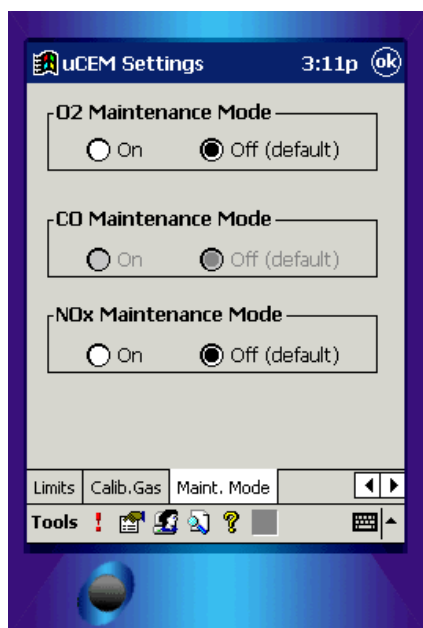

Figure 3-15. Maintenance Mode Settings

3-4 MicroCEM FACTORY SETTINGS

A MicroCEM Factory Settings program is available for use by MicroCEM technicians to set parameters in the MicroCEM or a qualified customer technician. Enter the Factory Settings password at the login dialog to enter the Factory Settings. This

password will not be provided to the customer. The list of settings is shown in Table 3-3 and Table 3-4.

The user must purchase a PC/104 to mouse and PC/104 to monitor in order to access the factory settings. Consult Rosemount for details.

Model MicroCEM

Calibration Setting	Description	
O2ZeroDriftLimit	O2 Allowed Zero Drift Limit.	If the drift exceeds the allowed amount a drift alarm will occur, and the readings on the channel will no longer be valid until a successful calibration is completed.
COZeroDriftLimit	CO Allowed Zero Drift Limit.	
NOXZeroDriftLimit	NOx Allowed Zero Drift Limit.	
OSMidDriftLimit	O2 Allowed Mid Drift Limit.	
COMidDriftLimit	CO Allowed Mid Drift Limit.	
NOXMidDriftLimit	NOx Allowed Mid Drift Limit.	
O2SpanDriftLimit	O2 Allowed Span Drift Limit.	
COSpanDriftLimit	CO Allowed Span Drift Limit.	
NOXSpanDriftLimit	NOx Allowed Span Drift Limit.	
O2Slope	Default value for the O2 slope	Initial values for the emissions conversion slope and offset used on a new system before the first Calibration is performed. These values should be set manually before the first auto-calibration is performed.
O2Offset	Default value for the O2 offset	
COSlope	Default value for the CO slope	
COOffset	Default value for the CO offset	
NOXSlope	Default value for the NOx slope	
NOXOffset	Default value for the NOx offset	
O2SpanDef	Default O2 Span Calibration Gas value	
O2MidSpanDef	Default O2 Mid Span Calibration Gas value	
COSpanDef	Default CO Span Calibration Gas value	
COMidSpanDef	Default CO Mid Span Calibration Gas value	
NOXSpanDef	Default NOx Span Calibration Gas value	
NOXMidSpanDef	Default NOx Mid Span Calibration Gas value	
Gas1Allocation	Default Gas 1 allocation	Default allocation for O2/NOx/CO. 1 = Zero, 2 = Mid Span, 3 = Span. Example: 133 = O2=Zero,NOx=Span,CO=Span
Gas2Allocation	Default Gas 2 allocation	
Gas3Allocation	Default Gas 3 allocation	
AutoCalFrequency	Default Auto-Calibration frequency in hours and minutes (example: 24:00).	
AutoCalTime	Default Auto-Calibration time in hours and minutes (military time).	
Purge1	Default auto-calibration Purge 1 value in seconds.	
Gas1	Default auto-calibration gas 1 time in seconds.	
Gas2	Default auto-calibration gas 2 time in seconds.	
Gas3	Default auto-calibration gas 3 time in seconds.	
Purge2	Default auto-calibration Purge 2 value in seconds.	

Table 3-3. Factory Settings – Calibration

General Setting	Description
O2SensorLowLimit	This sets the O2 % low limit, below which a limit alarm will occur.
O2SensorHighLimit	This sets the O2 % high limit, above which a limit alarm will occur.
COSensorLowLimit	This sets the CO low limit, below which a limit alarm will occur.
COSensorHighLimit	This sets the CO ppm high limit, above which a limit alarm will occur.
NOXSensorLowLimit	This sets the NOx low limit, below which a limit alarm will occur.
NOXSensorHighLimit	This sets the NOx ppm high limit, above which a limit alarm will occur.
CCEM Serial Number	This setting is used to record the MicroCEM Serial Number.
Diluent Percent	Percent O2 used in Diluent correction.
MinimumOnCurrent	This is the minimum current that must be measured by a current analog input for a heater/cooler/fan to be considered on. This is used for heater/cooler/fan failure detection.
MaximumOffCurrent	This is the maximum current that must be measured by a current analog input for a heater/cooler/fan to be considered off. This is used for heater/cooler/fan failure detection.
NDIR Sync Low	This indicates which NDIR reading is made when the sync goes from high to low: Reference (R) or Sample Gas (S).
+24V Low Limit	If the +24V measurement is below this level it will cause an alarm.
+24V High Limit	If the +24V measurement is above this level it will cause an alarm.
ValveOnTime	For calibration – The amount of time to wait after turning on a valve.
O2EmissionLimit	These limits are the default values. On the Pocket PC these values will be used when one of the “Defaults” buttons are pressed.
NOXEmissionLimit	
COEmissionLimit	
O2LowRange	
COLowRange	
NOXLowRange	
O2HighRange	
COHighRange	
NOXHighRange	
SamplePumpOn	1 = Sample pump is used. 0 = Sample pump not used.
LogsDir	Directory where log files are saved (C:\uCEM\Logs).
MaxWarmUpTime	Maximum time allowed for the uCEM to warm-up when it is started up. If all temperature zones are not within allowed range within this period of time, the uCEM will shutdown all heaters, coolers and processes.
StateFile	The full path to the file which maintains the state of the uCEM. (C:\uCEM\mcem.state)
ServerIP	The IP address to use when listening for incoming connections.
ServerPort	The IP Port to use when listening for incoming connections.
ServerTimeout	100
AlarmsPersistFile	The full path to the file which maintains the current state of the alarms. (C:\uCEM\alarms.state)
LogoffTimeout	Auto Log-off time in minutes
UserListPersistFile	The full path to the file that maintains the user list (C:\uCEM\mcem.userlist)

Table 3-4. Factory Settings - General

Model MicroCEM

a. PID Control Loop Factory Settings

These settings can be set for each of the temperature control loops. The temperature control loops include the

Zone heater/cooler, Converter Heater, PMT Heater, and PMT Photo Diode Cooler. Table 3-5 shows the section names in the INI file used for each temperature control loop.

Control Loop	Section Name
Zone Heater/Cooler	[PIDSettings ZoneLoop]
Converter Heater	[PIDSettings ConverterLoop]
PMT Heater	[PIDSettings PMTLoop]
PMT Photo Diode Cooler	[PIDSettings PDTLoop]

Table 3-5. PID Settings – Section Names

PID Setting	Description
PSetting	Proportional Gain. This parameter is set by using typical PID tuning methods. The P setting is mandatory and is the first parameter to adjust. It provides a command directly proportional to the error.
ISetting	Integral Gain. This parameter is set by using typical PID tuning methods. The I setting is optional and is used to make small adjustments to correct a small error which persists for a period of time.
DSetting	Derivative Gain. This parameter is set by using typical PID tuning methods. The D setting is optional. It is used to adjust the command based on change in error. It can be used to reduce overshoot, which typically occurs when the P settings is used by itself. This parameter tends to amplify any noise present in the input.
MaxSpeedSetting	Should be set to the typical warm-up/cool-down speed in °C/second when the heater/cooler is operated at 100% power. Increasing this value effectively decreases the Proportional, Integral and Derivative gain. Decreasing this value effectively increases the Proportional, Integral and Derivative gain.
ResetIntegralError	Integral Reset Error. Setting used to reset Integral value when error is larger than this value. This parameter is used to prevent the integral value from building up while the error is large and then causing overshoot when the setpoint is reached.
IntegralMaxPercent	Maximum percent output power that can be accumulated by the Integral component. (0-100) The default is 10 percent.
IntegralMinPercent	Minimum percent output power that can be accumulated by the Integral component. (0-100) The default is 10 percent.
MaxPercent	Maximum zone output power in percent (0-100).
MinPercent	Minimum zone output power in percent (0-100).
MinAlternationPercent	Minimum
SetPoint	This is the temperature setpoint, in degrees Celsius, for this temperature control loop.
LowTempLimit	If the temperature (°C) is below this value during the MicroCEM process (not including the warm-up phase) an alarm will occur.
HighTempLimit	If the temperature (°C) is above this value during the MicroCEM process (not including the warm-up phase) an alarm will occur.
MaxOffCurrent	If the current reading is below the maximum-off current while the heater is turned off, the heater has failed with a Heater Control failure.
MinOnCurrent	If the current reading is below the minimum-on current while the heater is turned on, the heater has failed with a Heater Burnout status.

Table 3-6. PID Settings – Sections Descriptions

Model MicroCEM

3-5 MicroCEM ADMINISTRATION

The MicroCEM Administration dialog is only available to users with MicroCEM Administration permission. If a user is not currently logged in, the login dialog will be displayed. If the current user doesn't have MicroCEM Administration permission, a message will be displayed which reads "Permission denied". When the MicroCEM Administration is invoked from the Tools menu or the MicroCEM Administration button, the MicroCEM Administration tabbed dialog is displayed. The User Settings page (tab) is displayed initially.

a. User Settings

The user settings page of the MicroCEM Administration dialog allows users to be added, deleted or modified. Each user has a name, password, and permission settings. The permission settings include Settings permission that allows access to the MicroCEM Settings dialog, and Administrative permission that allows access to the MicroCEM Administration dialog. The Settings permission also allows a user to access the MicroCEM remotely using the web-based interface.

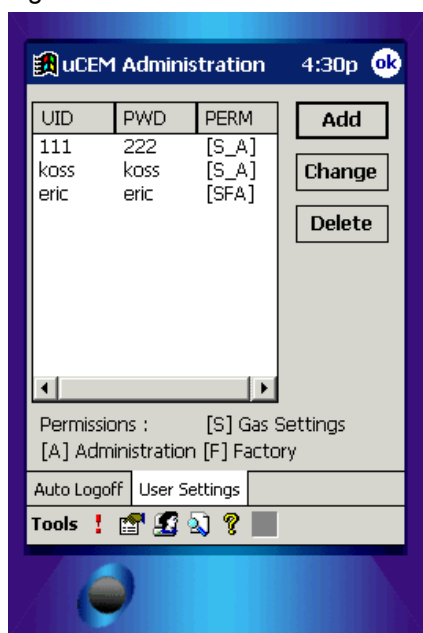

Figure 3-16. User Settings

b. Auto Logoff

The number of minutes of inactivity after which a user is automatically logged off is set on the Auto Logoff page of the MicroCEM Administration.

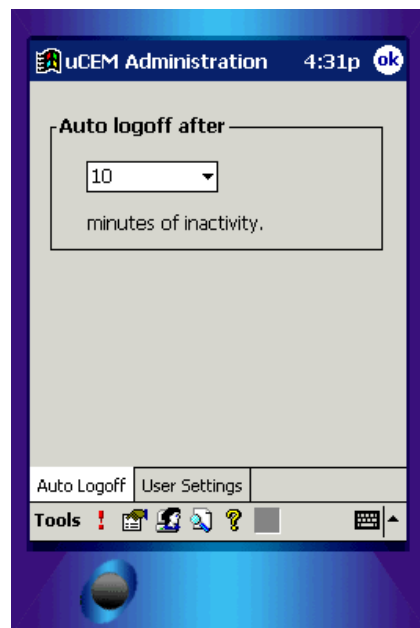

Figure 3-17. Auto Logoff

3-6 MicroCEM DATA LOGS

The MicroCEM maintains a minimum of 3 months of history in three types of data log files. The first type of log file is the measurement log, which contains emission measurements (at 1 minute intervals), alarm indications and maintenance mode indications. The second type of log file is the calibration log file, which contains information on each auto calibration done. The third is the alarm log file, which records any improperly functioning hardware. The data will be stored in flat, ASCII, CSV (comma-delineated) file. This file format can be read directly by MS Excel and imported into many types of software applications. The following parameters is factory set for each of the log file types.

a. Maximum Log File Size

This is how large a log file can get (in bytes) before it is closed and a new log file is opened.

Emissions Log:	1 MB
Calib Log:	4000 bytes
Alarm Log:	4000 bytes

b. Maximum Number of Log Files

This is how many log files can be created. When the maximum number of log files is reached, the oldest file is overwritten when new ones are created.

Emissions Log:	6
Calib Log:	6
Alarm Log:	6

c. Log File Name Format

The log file name uses the date that the file was created. It is of the format *YYYYMMDD*.CSV where *T* is the log file type (E=Emissions, C=Calibration and A=Alarm), *YYYY* is the Year, *MM* is the month, and *DD* is the day of the month. For example, the file name **E20010329.csv** contains emissions data and was created on March 29, 2001.

d. Measurement Log File Format

The log file contains data in a flat, ASCII, CSV file. The following are the fields of the file, in order of occurrence. The log file size will be about 42 bytes per entry. 3 months of data logs will require about 5,443,200 bytes

Name	Description	Example
Date/Time	Month-day-year Hours:Minutes:Seconds	3-7-2001 10:24:57
O2	Percent O2 (percent)	10.5
CO	CO parts per million	12
NOx	NOx parts per million	15
CO Limit	CO Limit exceeded alarm, 0=inactive, 1=active	0
NOx Limit	NOx Limit exceeded alarm, 0=inactive, 1=active	0
O2 Status	V=Valid, M=Maintenance Mode, C=Calibration in process, I=Invalid (calibration failed or sensor in failed state)	V
CO Status	V=Valid, M=Maintenance Mode, C=Calibration in process, I=Invalid (calibration failed or sensor in failed state)	V
NOx Status	V=Valid, M=Maintenance Mode, C=Calibration in process, I=Invalid (calibration failed or sensor in failed state)	V

Table 3-7. Measurement Log File Format

Model MicroCEM

e. Calibration Log File Format

The log file contains data in a flat, AS-CII, CSV file. The following are the

fields of the file, in order of occurrence. The log file size will be about 178 bytes per entry. 3 months of data logs will require about 16000 bytes (based on Calibration performed every 24 hours).

Name	Description	Example
Date/Time	Month-day-year Hours:Minutes:Seconds	3-7-2001 10:24:57
Zero Time	Time that Zero span started, Hours:Minutes:Seconds	10:25:30
Mid Time	Time That Mid span started, Hours:Minutes:Seconds	10:27:30
Span Time	Time that span started, Hours:Minutes:Seconds	10:28:30
Purge Time	Time that the final purge started, Hours:Minutes:Seconds	10:30:30
Finish Time	Time that the final purge finishes	10:31:00
O2 Measured Zero	Measured percent O2 for Zero phase of calibration	0.0
O2 Expected Zero	Expected percent O2 for Zero phase of calibration	0.0
O2 Zero Drift	Percent drift of O2 zero calibration	0.0
O2 Measured Mid Span	Measured percent O2 for Mid span phase of calibration	10.1
O2 Expected Mid Span	Expected percent O2 for Mid span phase of calibration	10.0
O2 Mid Drift	Percent drift of O2 mid calibration.	-0.4
O2 Measured Span	Measured percent O2 for Span phase of calibration	20.2
O2 Expected Span	Expected percent O2 for Span phase of calibration	20.3
O2 Span Drift	Percent drift of O2 span calibration	0.4
CO Measured Zero		1
CO Expected Zero		0
CO Zero Drift		0.3
CO Measured Mid Span		23
CO Expected Mid Span		24
CO Mid Span Drift		-0.3
CO Measured Span		45
CO Expected Span		45
CO Span Drift		0
NOx Measured Zero	Measured ppm NOx for zero phase of calibration	15
NOx Expected Zero	Expected ppm NOx for zero phase of calibration	15
NOx Zero Drift		0
NOx Measured Mid Span	Measured ppm NOx for mid span phase of calibration	30
NOx Expected Mid Span	Measured ppm NOx for mid span phase of calibration	30
NOx Mid Span Drift		0
NOx Measured span	Measured ppm NOx for span phase of calibration	59
NOx Expected span	Measured ppm NOx for span phase of calibration	59
NOx Span Drift		0

Table 3-8. Calibration Log File Format

f. Alarm Log File Format

The log file contains data in a flat, AS-CII, CSV file. The following are the fields of the file, in order of occurrence.

The days or months maintained in the Alarm Log depends on how often trouble conditions are recorded. If there are rarely alarm conditions recorded, there is enough space for many years of alarm logs to be recorded.

Name	Description	Example
Date/Time	Month-day-year Hours:Minutes:Seconds	3-7-2001 10:24:57
Fault Level	1=informational, 2=warning, 3=critical	3
Fault Type	0 = O2 Calibration Failed 1 = CO Calibration Failed ** 2 = NOx Calibration Failed 3 = O2 High Limit 4 = O2 Low Limit 5 = CO High Limit ** 6 = CO Low Limit ** 7 = NOx High Limit 8 = NOx Low Limit 9 = O2 Emission Limit 10 = CO Emission Limit ** 11 = NOx Emission Limit 12 = 5 Volt Fault ** 13 = 6 Volt Fault ** 14 = 24V Over Max 15 = 24 Low Min 16 = Converter Over Temp 17 = Converter Low Temp 18 = Converter On Failed ** 19 = Converter Off Failed ** 20 = Zone Over Temp 21 = Zone Low Temp 22 = Zone Heater On Failed ** 23 = Zone Heater Off Failed ** 24 = Zone Cooler On Failed ** 25 = Zone Cooler Off Failed ** 26 = Heater Fan On Failed ** 27 = Heater Fan Off Failed ** 28 = Cooler Fan On Failed ** 29 = Cooler Fan Off Failed ** 30 = PDT Over Temp 31 = PDT Low Temp 32 = PDT On Failed ** 33 = PDT Off Failed ** 34 = PMT Over Temp 35 = PMT Low Temp 36 = PMT On Failed ** 37 = PMT Off Failed ** 38 = O2 Over Temp ** 39 = O2 Low Temp ** 40 = O2 On Failed ** 41 = O2 Off Failed ** 42 = Warmup Time Limit 70 = IO Board Failed	2
Fault Description	ASCII string describing fault. Up to 200 characters.	CO Calibration Failed

** - Alarm is not implemented in this version of software or reserved for future use.

Table 3-9. Alarm Log File Format

Model MicroCEM

3-7 VIEW DATA LOGS

View Data Logs will start Internet Explorer and display the Emissions page of the Mi-

croCEM web pages (see Figure 3-18 and Figure 3-19). This page can be used to view the Emissions log. Other pages may be selected to view the calibration log and the alarm log.

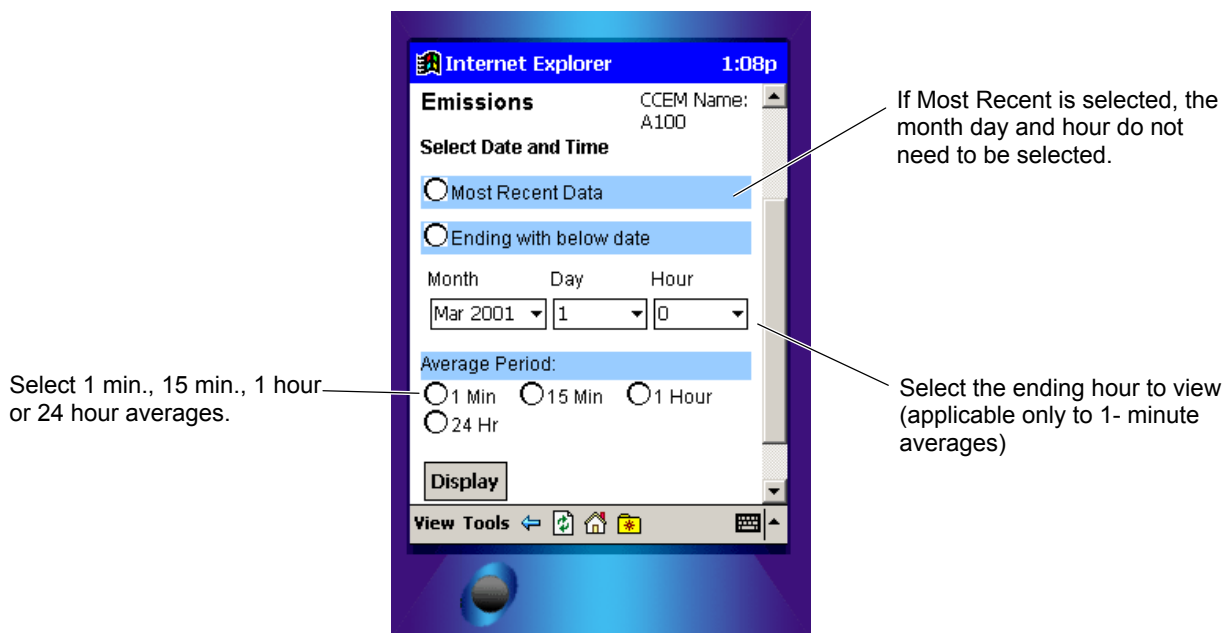

Note the page header was scrolled out of view to show all the selection options, but it can be seen in Figure 3-19.

Figure 3-18. View Data Logs

Average Period	Time Range Displayed
1 Minute	1 Hour
15 Minutes	1 Day
1 Hour	3 Days
12 Hours	1 Month
24 Hours	3 Months

Table 3-10. Average Period Selection

NOTE

The Real-time, Config and Download are included in the navigation menu but these pages are intended for remote desktop use. As an enhancement these items could be hidden if the pages are browsed from a Windows CE version of Internet Explorer.

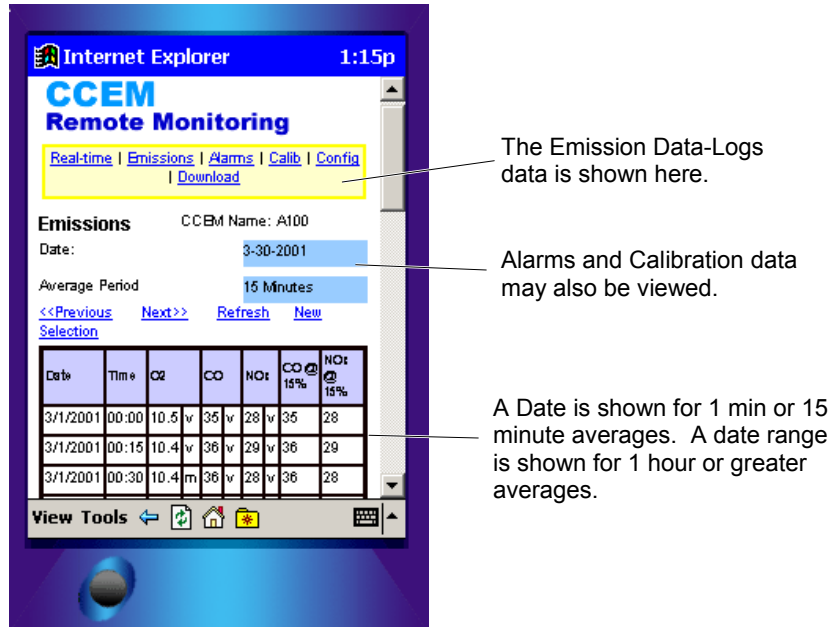

Figure 3-19. View Data Logs Table

Model MicroCEM

3-8 VIEWING MicroCEM DATA WITH A WEB BROWSER

The log files may be accessed using a web browser that has access to the MicroCEM over a Wireless LAN, serial port connection (PPP) or Dialup Connection (RAS). The MicroCEM has Window CE Web Server installed and provides a Web-based interface to select and download the Data-Log files. The downloaded Data-Log files will be in a

CSV (comma delineated ASCII) format. The log files may also be viewed as a web page in a tabular format.

a. Real-Time Page

The Real-Time page provides a real-time display of the emission values and emission statuses. The display is refreshed every 10 seconds.

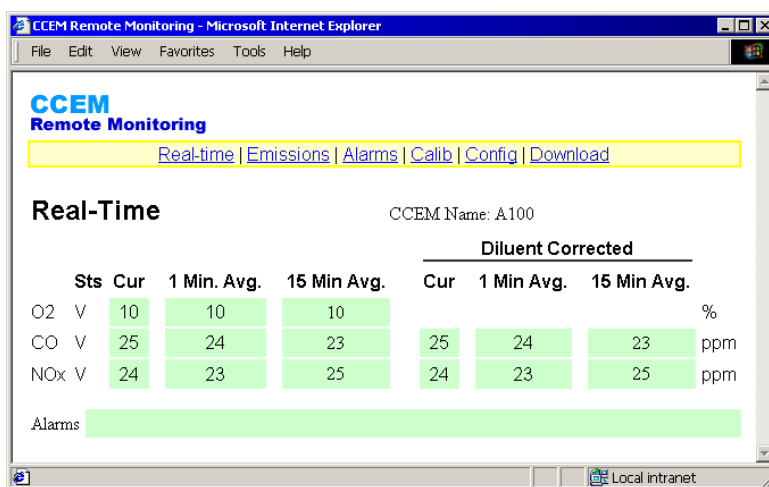

Figure 3-20. Real-Time Web Page

b. Emissions Page

The Emissions Page can be used to view emission history in a tabular web-page format. This page is used as part of the MicroCEM User interface as well as by a remote user (probably from a desktop computer).

The Emission Data-Logs table is displayed (as shown in Figure 3-19) after selecting the Date and Average Period

and pressing the Display button. If desired a bookmark or shortcut may be made to the page displaying the table. In the future, the same table can be displayed by selecting this bookmark. If Most Recent Data was selected, the book-marked page will always display Most Recent Data. If a specific date was specified, the book-marked page will always display the same date.

If Most Recent is selected, the month day and hour do not need to be selected.

Select 1 min., 15 min., 1 hour or 24 hour averages.

Select the ending hour to view (applicable only to 1 minute averages)

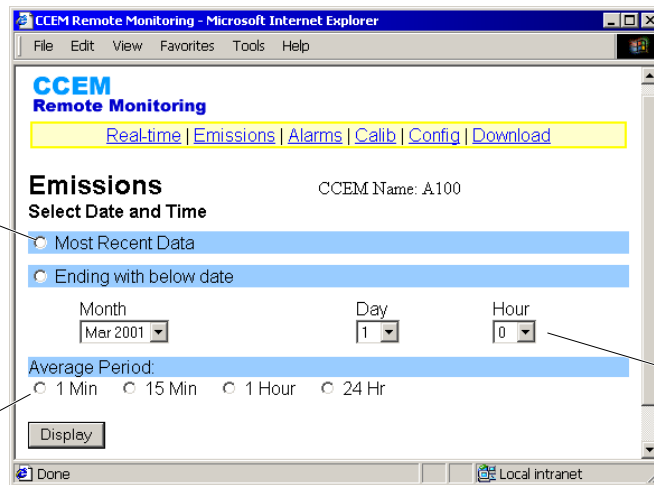

Figure 3-21. Emissions Selection

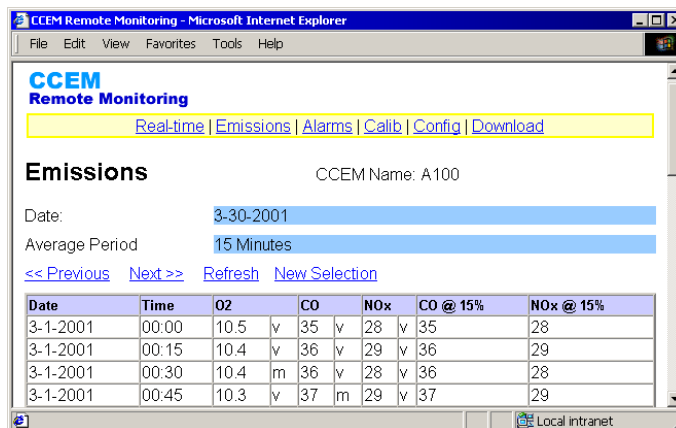

Figure 3-22. Emissions Table

CCEM Remote Monitoring
[Real-time](#) | [Emissions](#) | [Alarms](#) | [Calib](#) | [Config](#) | [Download](#)

Calibrations CCEM Name: A100

Date: 3-30-2001 through 4-30-2001

[<<Previous](#) [Next>>](#) Refresh New Selection

Date	Time	O2 Zero	O2 Zero Exp.	O2 Zero Drift	O2 Mid	O2 Mid Exp.	O2 Mid Drift	O2 Span	O2 Span Exp.	O2 Span Drift	CO Zero	CO Zero Exp.	CO Zero Drift	CO Mid	CO Mid Exp.	CO Mid Drift	CO Span	CO Span Exp.	CO Span Drift	NOx Zero	NOx Zero Exp.	NOx Zero Drift	NOx Mid	NOx Mid Exp.	NOx Mid Drift	NOx Span	NOx Span Exp.	NOx Span Drift
3-1-2001	01:00	0.0	0.0	0.0	10.0	10.0	0.0	20.0	20.0	0.0	0.0	0.0	0.0	150.0	150.0	0.0	240.0	240.0	0.0	0.0	0.0	0.0	150.0	150.0	0.0	240.0	240.0	0.0
3-2-2001	01:00	0.0	0.0	0.0	10.0	10.0	0.0	20.0	20.0	0.0	0.0	0.0	0.0	150.0	150.0	0.0	240.0	240.0	0.0	0.0	0.0	0.0	150.0	150.0	0.0	240.0	240.0	0.0
3-3-2001	01:00	0.0	0.0	0.0	10.0	10.0	0.0	20.0	20.0	0.0	0.0	0.0	0.0	150.0	150.0	0.0	240.0	240.0	0.0	0.0	0.0	0.0	150.0	150.0	0.0	240.0	240.0	0.0
3-4-2001	01:00	0.0	0.0	0.0	10.0	10.0	0.0	20.0	20.0	0.0	0.0	0.0	0.0	150.0	150.0	0.0	240.0	240.0	0.0	0.0	0.0	0.0	150.0	150.0	0.0	240.0	240.0	0.0
3-5-2001	01:00	0.1	0.0	0.0	10.0	10.0	0.0	20.0	20.0	0.0	0.0	0.0	0.0	150.0	150.0	0.0	240.0	240.0	0.0	0.0	0.0	0.0	150.0	150.0	0.0	240.0	240.0	0.0

Figure 3-23. Calibration Table

c. Download Page

The download page of the MicroCEM allows the selection and download of the three types of Data-Logs. To quickly download recent data, a “Download Most Recent Emissions Data” selection is provided. For more control over the date range, a “Download Emissions by Date Range” selection is available. Once the selection is

made, press the Download button to start the HTTP download. The MicroCEM will create a temporary file that contains the selected data. Due to memory limitations there is a limit to the number of files that can be downloaded simultaneously. If this limit is exceeded, a message will be displayed that reads “The simultaneous download limit has been reached, please try again later”.

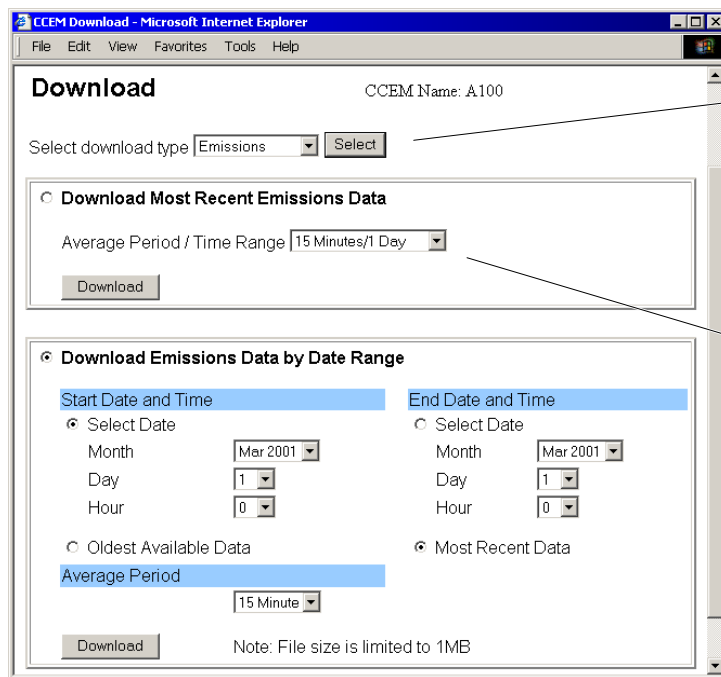

Download Emissions Log, Calibration Log or Alarm Log

- Choose from:
- 1 Minute / 8 Hours
 - 1 Minute / 1 Day
 - 1 Minute / 1 Week
 - 15 Minutes / 1 Day
 - 15 Minutes / 1 Week
 - 15 Minutes / 1 Month
 - 15 Minutes / 3 Months
 - 1 Hour / 1 Week
 - 1 Hour / 1 Month
 - 1 Hour / 3 Months

Figure 3-24. Download Web Page

Model MicroCEM

3-9 VIEWING MicroCEM DATA WITH MS EXCEL

The MicroCEM Data may be view with MS Excel using two different methods. The first method is to open the data log files that have been downloaded onto a workstation. The files may then be opened directly with Excel. The second method is to create an Excel workbook, which links to the MicroCEM web page. This is described in the following paragraph.

An Excel spreadsheet may be linked to a MicroCEM web site, which periodically refreshes the spreadsheet with data from the web site. To do this, first make sure the MicroCEM web site is

available. The workstation needs access to the MicroCEM web site via RAS (Dialup), LAN or the Internet. Then in Excel, select Data menu, Get External Data, New Web Query. The dialog shown in Figure 3-25 will appear. Type in the address for a MicroCEM web page that contains a table with the desired data. Then press OK and click on the cell where the data should appear. The data will then appear in the spreadsheet. To have the data updated periodically, right-click on one of the cells that contains the linked data and select Data Range Properties. Check the box the reads "Refresh Every" and set the refresh period. For additional information refer to MS Excel documentation.

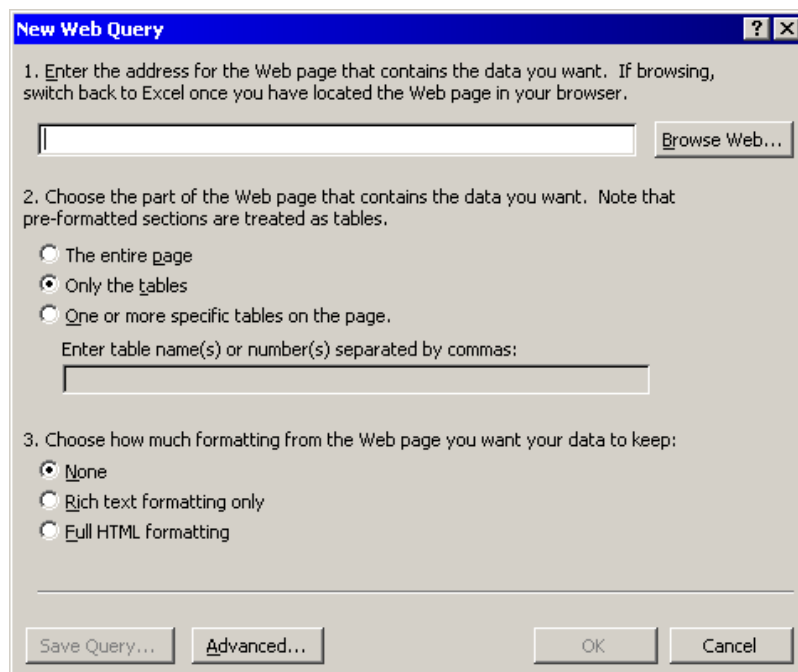
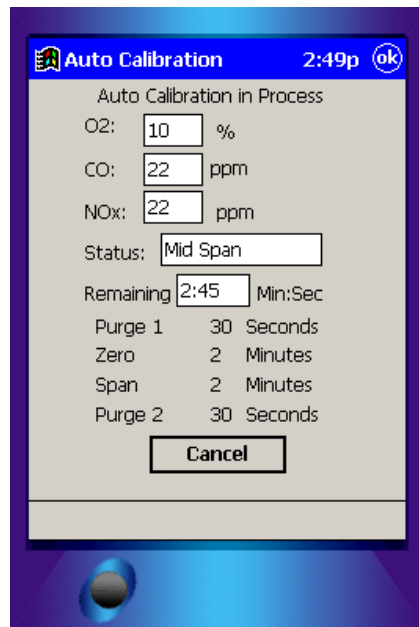

Figure 3-25. New Web Query

3-10 AUTO CALIBRATION

The Auto Calibration dialog is displayed whenever calibration is in process. It dis-

plays the current emission values and the status of the calibration. The calibration may be canceled before it completes by pressing the Cancel button.



Note: The title of this dialog will read either “Auto Calibration” or “Manual Calibration” to indicate how the calibration process was initiated.

Figure 3-26. Auto Calibration

Model MicroCEM

SECTION 4 SOFTWARE

4-1 OVERVIEW

The MicroCEM Software includes 3 main components. One component is the MicroCEM control software that interfaces with the instrumentation and records the emissions measurements. A second component is the User Interface Software that provides real-time status and configuration dialogs. A third component is the web server software that uses VB Script or Java Script to provide a web-based interface to the MicroCEM.

4-2 MicroCEM USER INTERFACE SOFTWARE

Hardware Platform: Pocket PC

The MicroCEM User Interface Software communicates with the MicroCEM Control Software using TCP/IP. It may run locally on the MicroCEM computer or remotely on a Pocket PC with a RS232 connection to the MicroCEM

computer. It will not normally run locally since there is no input device or display connected to the MicroCEM processor.

4-3 MicroCEM WEB SERVER SOFTWARE

Web Browser: Internet Explorer 4.0 or Netscape 4.0

The Web Server Software provides the web based interface described in this document. It is implemented as a VB Script or Java Script. The script will obtain much of the needed information directly from the Data-Log files or configuration file. The real-time information will be obtained from a memory segment shared with the MicroCEM control software. The web server support multiple simultaneous clients. The maximum number of allowed connections could be limited to a reasonable number through the Windows CE Web Server configuration dialogs.

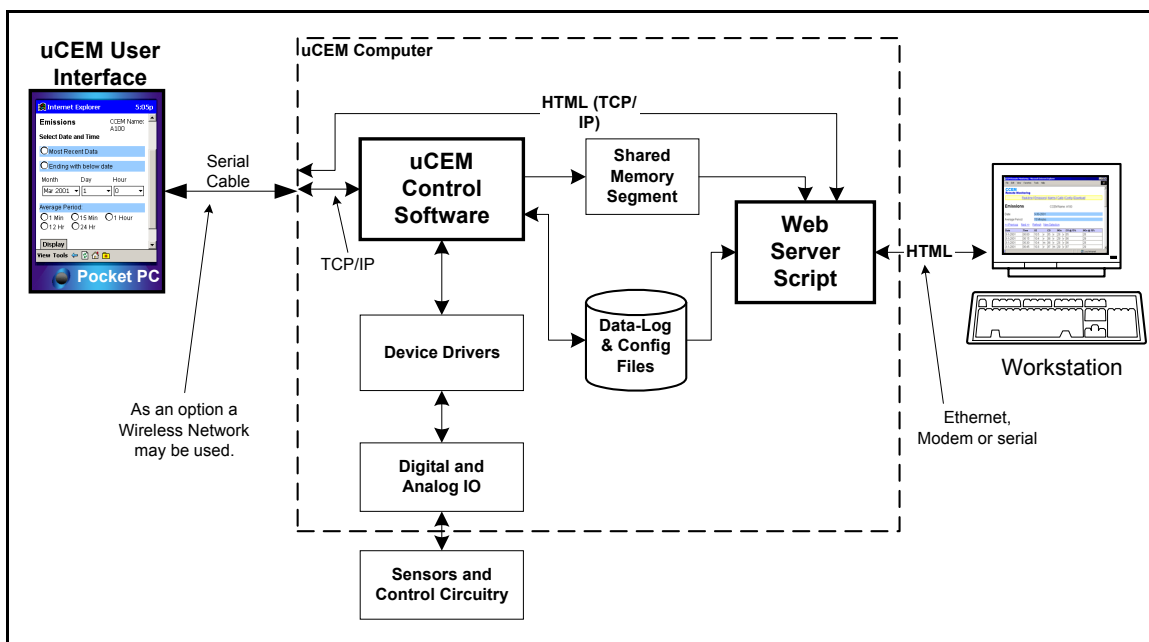

Figure 4-1. MicroCEM Software Block Diagram

4-4 SOFTWARE DEVELOPMENT MANAGEMENT

Microsoft Visual SourceSafe is used for version control of all of the MicroCEM software. Compuware's Track Record is used for change request management and defect tracking.

SECTION 5 MAINTENANCE AND SERVICE

DANGER

ELECTRICAL SHOCK HAZARD

Disconnect power to the module(s) prior to replacing components.

WARNING

QUALIFIED PERSONNEL

This equipment should not be adjusted or repaired by anyone except properly qualified service personnel.

WARNING

PARTS INTEGRITY

Tampering with or unauthorized substitution of components may adversely affect safety of this product. Use only factory-approved components for repair.

5-1 OVERVIEW

The MicroCEM Analyzer Module requires very little maintenance during normal operation.

Occasionally, the detector's reaction chamber and sapphire window may require cleaning, refer to Section 5-5.

White crystal deposits on the windows of the reaction chamber and plugging of capillaries and vent are usually due to sample contaminants such as ammonia reacting with the high ozone levels and NO components. To eliminate the contaminants, the sampling system should be reworked or a preventive maintenance program developed (if dropout is not excessive). Another source of crystalline formation is contaminated air.

Several components may require replacement. These are discussed in the following sections.

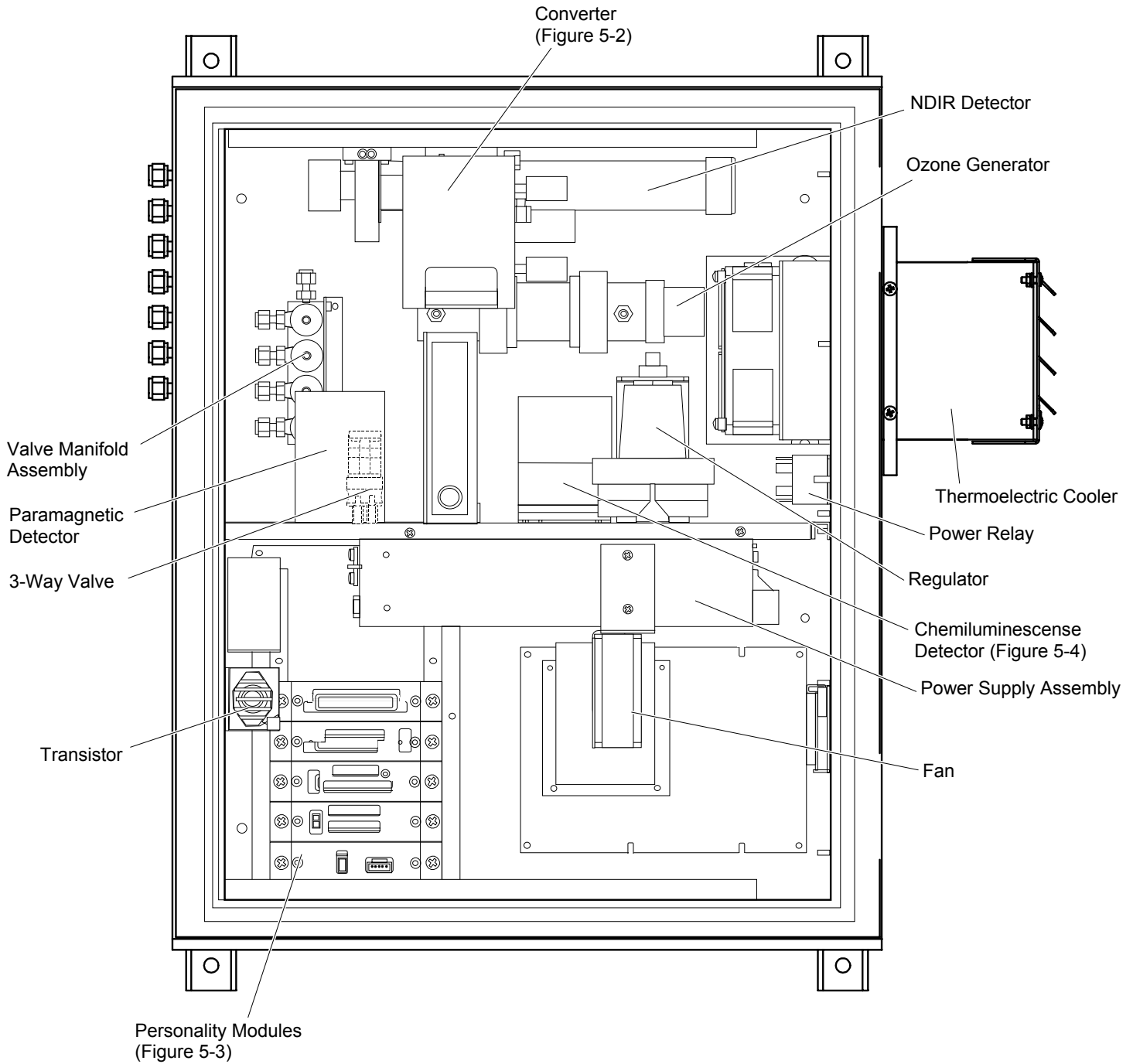

Figure 5-1. MicroCEM Component Location

5-2 CONVERTER

To replace the converter or sensor, disconnect the two pneumatic tubes and two electrical connections. Unlace the heater blanket,

and remove the converter. Reassemble in reverse order, ensuring that the converter is oriented with the glass cloth at the bottom and the sensor is oriented correctly inside the heater jacket.

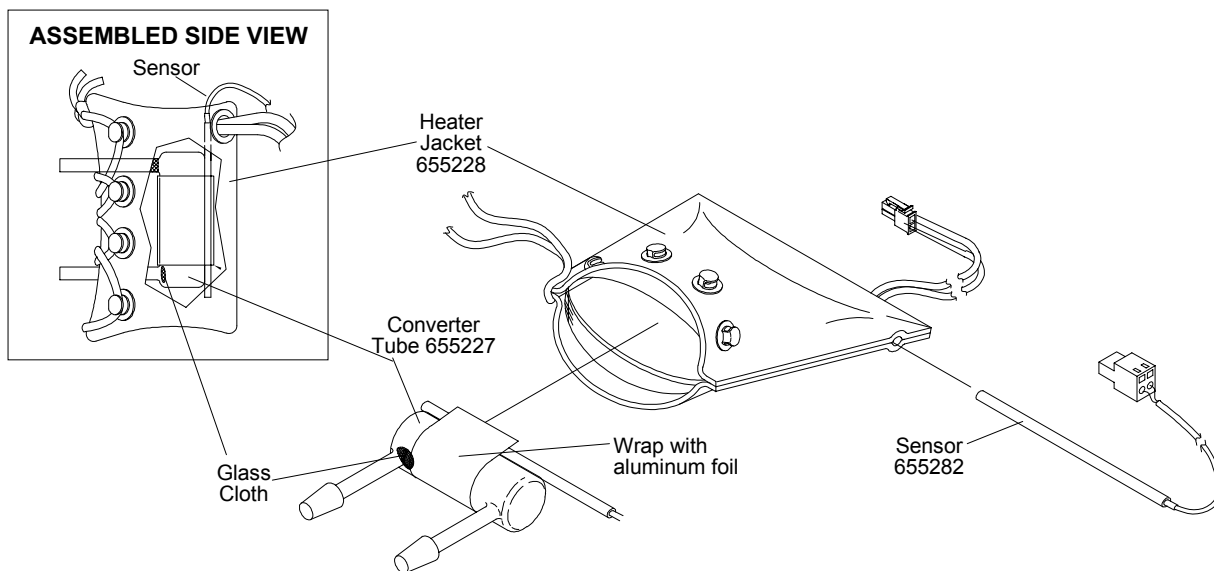

Figure 5-2. Converter Assembly

5-3 OZONE GENERATOR

To replace the ozonator, remove the two large straps and all tie-wraps, and disconnect the one electrical connection. Reassemble in reverse order.

5-4 PERSONALITY MODULES

There are five different personality modules. Depending on your unit, you may have three, four or five modules installed. These person-

ality modules are installed on a custom backplane. See Figure 5-3.

To remove any on the personality modules. Remove cables form module to be removed, there are two screws at the bottom of each module. You will have to loosen each screw before you can remove the personality module.

Tag each cable and its location before disconnecting any wiring. This helps in re-assembly.

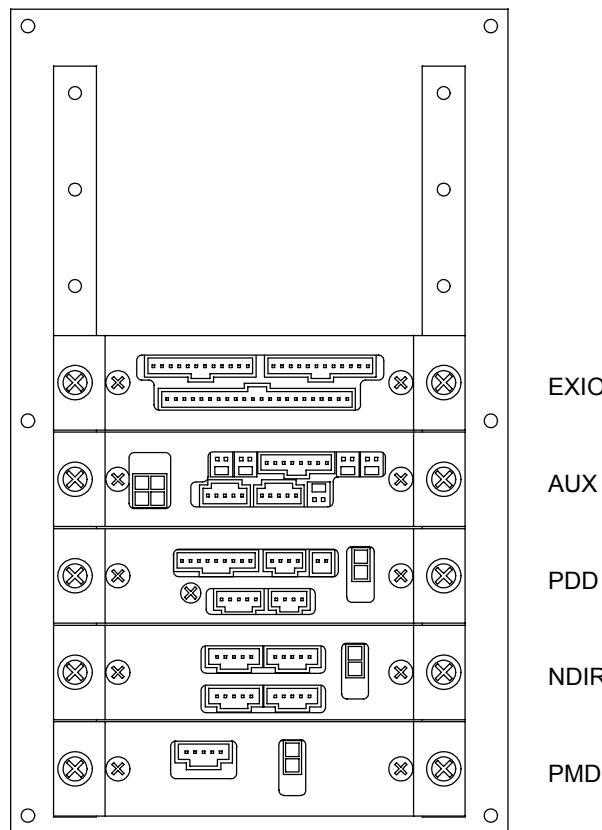

Figure 5-3. Personality Modules and Backplane.

5-5 CHEMILUMINESCENCE DETECTOR ASSEMBLY

Refer to Figure 5-4 and Figure 5-5.

a. Reaction Chamber

Removal

Disconnect the stainless steel tubing lines at the Gyrolok fittings. Remove the (4) nuts holding the Detector Assembly to the chassis. Disconnect the plug from connector J1 on the Signal Board and remove the assembly from the chassis.

NOTE

Heatsink Compound. Care should be taken to avoid getting heatsink compound on optical surfaces. If this substance is removed during the disassembly process, a zinc oxide-filled, silicone grease (e.g., Dow Corning 340 or EG&G Wakefield Engineering's Series 120 Thermal Joint Compound) be reapplied in the re-assembly of this component.

Although the heater and thermostat can be removed to facilitate handling, contact with the white heatsink compound can be minimized by leaving these items in place. Remove the (2) screws holding the top plate of the Detector , and move the plate along the wires and away from the Detector .

Remove the (2) screws holding the tube assembly in place. Hold the tubing with one hand while inverting the Detector Housing with the other, allowing the Reaction Chamber O-ring and window to be removed from below.

Installation

To reinstall, hold the housing in the inverted position while sliding the Reaction Chamber O-ring and window into position and the tubing into the slot in the housing. Hold the Reaction Chamber in place while rotating the housing upright. Replace the hold-down screws.

NOTE

Component Positioning. The procedure described above is for the purpose of maintaining the relative positions of windows and O-ring to the Reaction Chamber during installation.

Replace the top cap and screws. Reverse the removal procedure to reinstall the Detector Assembly into the Analyzer Module.

b. Photodiode

Removal

Remove the Detector Assembly as described above. Invert the housing to access the mounting bracket. Remove the (3) screws and shoulder washers from the bracket. Remove the bracket, insulating disk and bottom plate as a unit to minimize the spread of the heatsink compound.

Remove the (2) screws holding the lower section of the Detector Housing, then slide the section along the cable and remove.

Remove the (2) screws holding the socket, thermistor and photodiode in place, being careful not to lose the washers that are used as shims.

Grasp the socket and photodiode base while slowly rotating to separate the photodiode from the housing. Some friction will be felt as an O-ring is used around the photodiode as a seal.

Installation

To replace the photodiode, carefully remove the diode from the green socket, and replace with a new one. Before mounting the new diode, the top cap of the enclosure should be temporarily removed and the (2) screws holding the Reaction Chamber loosened about two turns. This allows air which is trapped between the O-ring seals to escape when the diode is inserted. It also maintains the

position of the O-ring and window in the upper compartment.

The new photodiode should be slowly inserted into the housing while gradually rotating the body. This allows the O-ring to properly seat. Continue replacing screws, washers, thermistors, etc., with the thicker shim (washer) on the opposite side of the socket from the thermistor.

Replace the lower section of the housing, then the bottom cover, insulator and bracket with the shoulder washers and screws.

Re-tighten the screws in the Reaction Chamber (upper section). Replace the top cap and its screws.

To reinstall in the Analyzer Module, reverse the procedure for removal as indicated above.

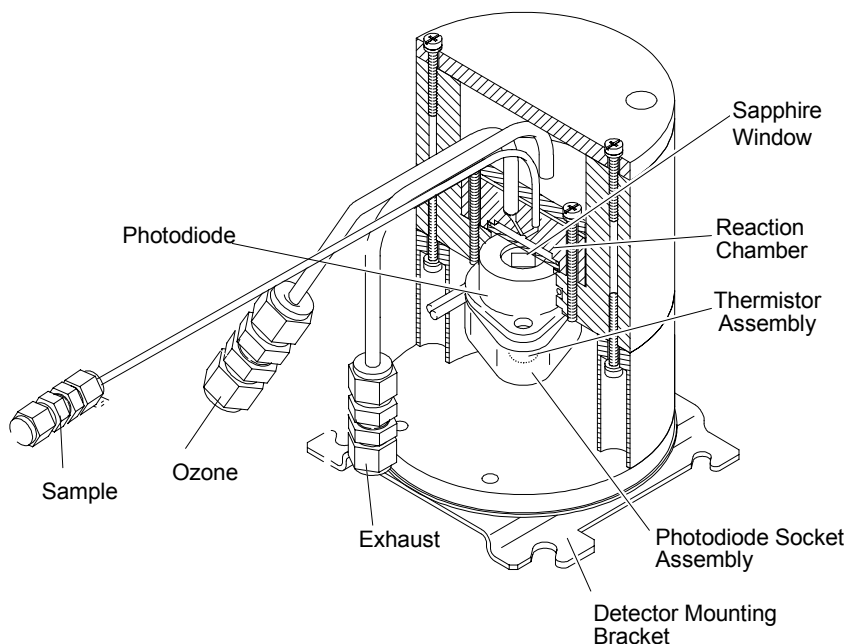

Figure 5-4. Chemiluminescence Detector Assembly

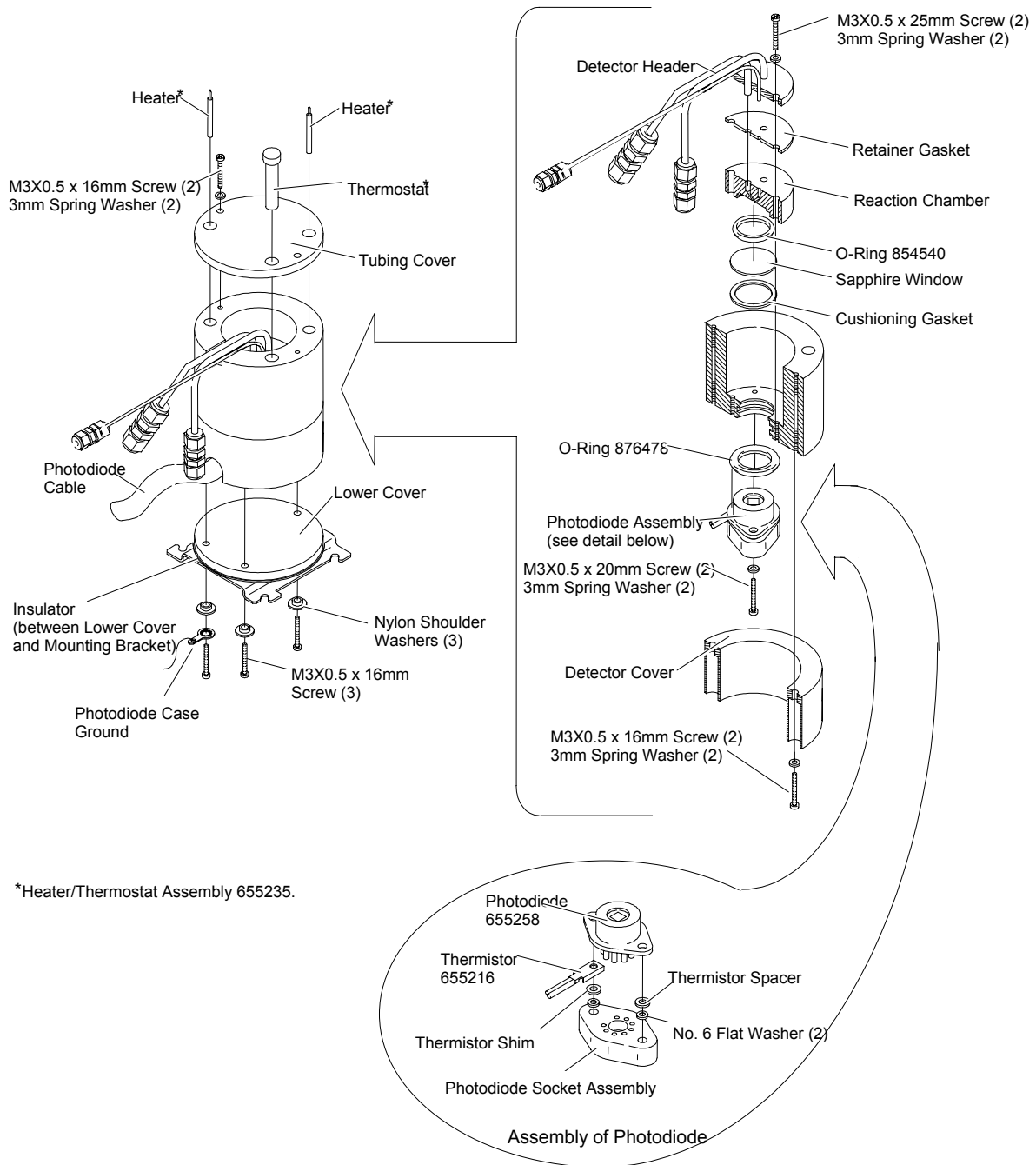

Figure 5-5. Chemiluminescence Detector Assembly – Exploded View

SECTION 6 TROUBLESHOOTING

6-1 TROUBLESHOOTING LEAKS

Liberally cover all fittings, seals, and other possible sources of leakage with a suitable leak test liquid such as SNOOP (part 837801). Bubbling or foaming indicates leakage. Checking for bubbles will locate most leaks but could miss some, as some areas are inaccessible to the application of SNOOP. For positive assurance that system is leak free, perform one of the tests above.

NOTE:

Refer to Specification in Preface for maximum pressure limitations.

For differential measurement, the leak check must be performed for the measurement and reference side separately.

For analyzers with parallel gas paths, the leak check must be performed for each gas path separately.

6-2 POCKET PC CONNECTION FAILURE

In the event the connection between the Pocket PC and the MicroCEM fails, a connection failure dialog will be displayed. It will display the following message:

Connection with uCEM lost, retrying...

A Cancel button will be displayed. The MicroCEM software will continue to attempt to reconnect with the MicroCEM indefinitely and will stop when a connection is made or the cancel button is pressed.

If the Cancel button is pressed, any setting changes that were made without pressing OK to accept will be lost. If Auto Calibration was in process, it will be completed by the MicroCEM even though the connection was lost.

6-3 TROUBLE LED

The Trouble LED output is activated whenever there is a critical alarm that has not been acknowledged. This provides both an output from the MicroCEM box and an LED indication.

SECTION 7 REPLACEMENT PARTS

1020839-100	PMD Module Assembly
1020840-100	NDIR Module Assembly
1020841-101	PDD Module Assembly
1020842-100	AUX Module Assembly
1020843-100	EXIO Module Assembly
1020869-100	Thermoelectric Cooler Assembly
1020973-100	Thermistor
1020987-100	Heater Assembly
42706504	Desiccant Bulbs
42711801	Electrical Cable
634398	Capillary, Vent
638614	Pressure Gauge
655216	Thermistor Assembly
655250	Converter Assembly
655289	Restrictor, Bulkhead
657716	Power Supply, Ozonator
657719	Ozone Generator
658157	Restrictor, Brass
659754	Photodiode Detector
90003311	Paramagnetic Detector
902124	Flowmeter
905778	4-Port Manifold
905779	2-Way Valve
905780	3-Way Valve
905871	Relay, Power 15A

SECTION 8 RETURN OF MATERIAL

8-1 RETURN OF MATERIAL

If factory repair of defective equipment is required, proceed as follows:

1. Secure a return authorization from a Rosemount Analytical Inc. Sales Office or Representative before returning the equipment. Equipment must be returned with complete identification in accordance with Rosemount instructions or it will not be accepted.
2. In no event will Rosemount be responsible for equipment returned without proper authorization and identification.
3. Carefully pack the defective unit in a sturdy box with sufficient shock absorbing material to ensure no additional damage occurs during shipping.
4. In a cover letter, describe completely:
 - a. The symptoms that determined the equipment is faulty.
 - b. The environment in which the equipment was operating (housing, weather, vibration, dust, etc.).
 - c. Site from where the equipment was removed.
 - d. Whether warranty or non-warranty service is expected.
 - e. Complete shipping instructions for the return of the equipment.
5. Enclose a cover letter and purchase order and ship the defective equipment according to instructions provided in the Rosemount Return Authorization, prepaid, to:

**Rosemount Analytical Inc.
Process Analytic Division
Customer Service Center
1-800-433-6076**

If warranty service is expected, the defective unit will be carefully inspected and tested at the factory. If the failure was due to the conditions listed in the standard Rosemount warranty, the defective unit will be repaired or replaced at Rosemount's option, and an operating unit will be returned to the customer in accordance with the shipping instructions furnished in the cover letter.

For equipment no longer under warranty, the equipment will be repaired at the factory and returned as directed by the purchase order and shipping instructions.

8-2 CUSTOMER SERVICE

For order administration, replacement parts, application assistance, on-site or factory repair, service or maintenance contract information, contact:

**Rosemount Analytical Inc.
Process Analytic Division
Customer Service Center
1-800-433-6076**

8-3 TRAINING

A comprehensive Factory Training Program of operator and service classes is available. For a copy of the Current Operator and Service Training Schedule, contact the Technical Services Department at:

**Rosemount Analytical Inc.
Phone 1-714-986-7600
FAX 1-714-577-8006**

WARRANTY

Goods and part(s) (excluding consumables) manufactured by Seller are warranted to be free from defects in workmanship and material under normal use and service for a period of twelve (12) months from the date of shipment by Seller. Consumables, glass electrodes, membranes, liquid junctions, electrolyte, o-rings, etc., are warranted to be free from defects in workmanship and material under normal use and service for a period of ninety (90) days from date of shipment by Seller. Goods, part(s) and consumables proven by Seller to be defective in workmanship and/or material shall be replaced or repaired, free of charge, F.O.B. Seller's factory provided that the goods, part(s) or consumables are returned to Seller's designated factory, transportation charges prepaid, within the twelve (12) month period of warranty in the case of goods and part(s), and in the case of consumables, within the ninety (90) day period of warranty. This warranty shall be in effect for replacement or repaired goods, part(s) and the remaining portion of the ninety (90) day warranty in the case of consumables. A defect in goods, part(s) and consumables of the commercial unit shall not operate to condemn such commercial unit when such goods, part(s) and consumables are capable of being renewed, repaired or replaced.

The Seller shall not be liable to the Buyer, or to any other person, for the loss or damage directly or indirectly, arising from the use of the equipment or goods, from breach of any warranty, or from any other cause. All other warranties, expressed or implied are hereby excluded.

IN CONSIDERATION OF THE HEREIN STATED PURCHASE PRICE OF THE GOODS, SELLER GRANTS ONLY THE ABOVE STATED EXPRESS WARRANTY. NO OTHER WARRANTIES ARE GRANTED INCLUDING, BUT NOT LIMITED TO, EXPRESS AND IMPLIED WARRANTIES OR MERCHANTABILITY AND FITNESS FOR A PARTICULAR PURPOSE.

Limitations of Remedy. SELLER SHALL NOT BE LIABLE FOR DAMAGES CAUSED BY DELAY IN PERFORMANCE. THE SOLE AND EXCLUSIVE REMEDY FOR BREACH OF WARRANTY SHALL BE LIMITED TO REPAIR OR REPLACEMENT UNDER THE STANDARD WARRANTY CLAUSE. IN NO CASE, REGARDLESS OF THE FORM OF THE CAUSE OF ACTION, SHALL SELLER'S LIABILITY EXCEED THE PRICE TO BUYER OF THE SPECIFIC GOODS MANUFACTURED BY SELLER GIVING RISE TO THE CAUSE OF ACTION. BUYER AGREES THAT IN NO EVENT SHALL SELLER'S LIABILITY EXTEND TO INCLUDE INCIDENTAL OR CONSEQUENTIAL DAMAGES. CONSEQUENTIAL DAMAGES SHALL INCLUDE, BUT ARE NOT LIMITED TO, LOSS OF ANTICIPATED PROFITS, LOSS OF USE, LOSS OF REVENUE, COST OF CAPITAL AND DAMAGE OR LOSS OF OTHER PROPERTY OR EQUIPMENT. IN NO EVENT SHALL SELLER BE OBLIGATED TO INDEMNIFY BUYER IN ANY MANNER NOR SHALL SELLER BE LIABLE FOR PROPERTY DAMAGE AND/OR THIRD PARTY CLAIMS COVERED BY UMBRELLA INSURANCE AND/OR INDEMNITY COVERAGE PROVIDED TO BUYER, ITS ASSIGNS, AND EACH SUCCESSOR INTEREST TO THE GOODS PROVIDED HEREUNDER.

Force Majeure. Seller shall not be liable for failure to perform due to labor strikes or acts beyond Seller's direct control.

Instruction Manual

748467-A
January 2002

Model MicroCEM

Emerson Process Management

Rosemount Analytical Inc. Process Analytic Division

1201 N. Main St.
Orrville, OH 44667-0901
T (330) 682-9010
F (330) 684-4434
E-mail: gas.csc@emersonprocess.com

EUROPEAN TECHNOLOGY CENTER

Fisher-Rosemount GmbH & Co.

Industriestrasse 1
63594 Hasselroth
Germany
Phone: 49-6055-884 0
Fax: 49-6055-884209

ASIA - PACIFIC

Fisher-Rosemount Singapore Private Ltd.

1 Pandan Crescent
Singapore 128461
Republic of Singapore
Phone: 65-777-8211
Fax: 65-777-0947

EUROPE, MIDDLE EAST, AND AFRICA

Fisher-Rosemount Ltd.

Heath Place
Bognor Regis
West Sussex PO22 9SH
England
Phone: 44-1243-863121
Fax: 44-1243-845354

LATIN AMERICA

Fisher - Rosemount

Av. das Americas
3333 sala 1004
Rio de Janeiro, RJ
Brazil 22631-003
Phone: 55-21-431-1882

<http://www.processanalytic.com>