



## MILLENNIUM II Multi-Channel Transmitter

### User Manual

### Single or Dual Channel



ISO 9001:2000



Part Number: MAN-0076 Rev 05  
December 07, 2012

## **IMPORTANT INFORMATION**

This manual is for informational purposes only. Although every effort has been made to ensure the correctness of the information, technical inaccuracies may occur and periodic changes may be made without notice. Net Safety Monitoring Inc., assumes no responsibility for any errors contained within this manual.

If the products or procedures are used for purposes other than as described in the manual, without receiving prior confirmation of validity or suitability, Net Safety Monitoring Inc., does not guarantee the results and assumes no obligation or liability. No part of this manual may be copied, disseminated or distributed without the express written consent of Net Safety Monitoring Inc.

Net Safety Monitoring Inc., products are carefully designed and manufactured from high quality components and can be expected to provide many years of trouble free service. Each product is thoroughly tested, inspected and calibrated prior to shipment. Failures can occur which are beyond the control of the manufacturer. Failures can be minimized by adhering to the operating and maintenance instructions herein. Where the absolute greatest of reliability is required, redundancy should be designed into the system.

## **WARRANTY**

Net Safety Monitoring Inc warrants its electronic assemblies against defective parts and workmanship for a period of 36 months from date of purchase. No other warranties or liability, expressed or implied, will be honored by Net Safety Monitoring Inc. Contact Net Safety Monitoring Inc. or an authorized representative for details.

We welcome your input at Net Safety Monitoring. If you have any comments please contact us at the phone/ address below or visit our web site and complete our on-line customer survey: [www.net-safety.com/](http://www.net-safety.com/)

If further language translation for this manual is required please contact:

## **CONTACT INFORMATION**

Net Safety Monitoring Inc  
Corporate Headquarters  
2721 Hopewell Place NE  
Calgary, AB Canada T1Y 7J7

Direct: (403) 219-0688  
Facsimile: (403) 219-0694  
E-mail: [nsmsales@net-safety.com](mailto:nsmsales@net-safety.com)  
Web-site: [www.net-safety.com/](http://www.net-safety.com/)

# TABLE OF CONTENTS

<b>IMPORTANT INFORMATION</b> .....	<b>2</b>
<b>WARRANTY</b> .....	<b>2</b>
<b>CONTACT INFORMATION</b> .....	<b>2</b>
<b>INTRODUCTION</b> .....	<b>5</b>
THE PRODUCT.....	5
TRANSMITTER/CONTROLLER.....	5
THE MANUAL.....	5
<i>Special conditions of use:</i> .....	5
<i>Housing Dimensions</i> .....	6
<b>SECTION 1: INSTALLATION</b> .....	<b>7</b>
1.1 UNPACK.....	7
1.2 MOUNTING.....	7
1.2.1 <i>Transmitter Orientation Option</i> .....	7
1.2.2 <i>Transmitter electronics module and Relay options</i> .....	8
1.2.3 <i>Rotating electronics module relative to enclosure and conduit entries</i> .....	9
<b>SECTION 2: WIRING AND INSTALLATION</b> .....	<b>10</b>
2.1 FIELD INSTALLATION.....	10
Guidelines.....	10
2.1.1 <i>Seals</i> .....	10
Guidelines.....	10
2.1.2 <i>Cable choice and guidelines</i> .....	11
2.1.3 <i>Analog output, isolated supply, non-isolated supply and jumper configuration</i> .....	13
2.1.4 <i>Remotely mounted sensors jumper configuration</i> .....	14
2.1.5 <i>Sensor and Transmitter terminals</i> .....	15
2.1.6 <i>Remote Reset</i> .....	16
2.1.7 <i>Sensor Separation/ Remote mounting of sensor</i> .....	16
2.1.8 <i>Wiring drawings</i> .....	17
2.1.9 <i>Installation Checklist</i> .....	19
<b>SECTION 3: TRANSMITTER AND FACEPLATE DESCRIPTION</b> .....	<b>20</b>
3.1 TRANSMITTER POWER UP.....	20
3.2 DISPLAY.....	20
3.3 STATUS LED.....	21
3.4 CURRENT LOOP MEASUREMENT (TEST JACKS).....	21
3.5 MENU BUTTONS AND ACCESS.....	21
3.5.1 <i>Intrusive Access</i> .....	21
3.5.2 <i>Non-Intrusive Access/Magnetic Reed switch Access</i> .....	21
<b>SECTION 4: OPERATION</b> .....	<b>22</b>
4.1 MENU OPTIONS.....	22
4.2 NAVIGATING MAIN MENU.....	22
4.2.1 <i>Full calibration (Normal calibration) procedure</i> .....	24
4.2.2 <i>(Cont'd) Zero calibration option</i> .....	25
4.2.3 <i>Enable / Disable channels</i> .....	27
4.2.4 <i>Viewing and setting alarm levels (points)</i> .....	27
4.2.5 <i>Setting Relay options</i> .....	28
4.2.6 <i>Relay Assignment</i> .....	28
4.2.7 <i>Relay Alarm Mode setting (for Oxygen sensors only)</i> .....	30

4.2.8 Select Display Language ..... 30

4.2.9 MODBUS Setup ..... 30

4.3.0 Setup Current Date ..... 31

4.3.1 Setup Current Time ..... 31

4.3.2 View Event Log ..... 32

4.3.3 Manual Reset ..... 33

4.3.4 Self Test Relay ..... 33

4.3.5 Sensor Upper Limit (Range) ..... 33

4.3.6 Select Gas Type ..... 34

4.3.7 Calibration gas value ..... 34

4.3.8 Serial Number & Firmware Version ..... 34

**SECTION 5: MONITORING AND OUTPUTS..... 35**

5.1 FAULT MONITORING ..... 35

5.2 RELAYS ..... 35

5.3 ANALOG 4-20MA ..... 35

*Sensor Status Registers, Transmitter Status LED, Current output and Meaning* ..... 36

5.4 RS-485 MODBUS RTU ..... 37

5.5 HART COMMUNICATION ..... 39

**SECTION 6: MAINTAINING..... 40**

6.1 PERIODIC RESPONSE CHECK ..... 40

6.2 TROUBLESHOOTING..... 40

6.3 STORAGE ..... 41

6.4 SPARE PARTS /ACCESSORIES..... 41

6.5 HOW TO RETURN EQUIPMENT ..... 42

**APPENDIX ..... 43**

**APPENDIX A: ELECTROSTATIC SENSITIVE DEVICE (ESD)..... 43**

**APPENDIX B: RESISTANCE TABLE ..... 44**

**APPENDIX C: MILLENNIUM II TRANSMITTER SPECIFICATIONS ..... 45**

# INTRODUCTION

Building on the outstanding legacy of the Millennium Series, Net Safety's latest innovation in this line of continuously evolving industrial transmitters and sensors, the Millennium II, pushes the boundaries of what you can expect from your detection system. Combined with state of the art "Smart" sensors, users will receive a detection system which is both versatile and reliable for fast, accurate and continuous monitoring of gases in extreme environments.

## ***THE PRODUCT***

### **TRANSMITTER/CONTROLLER**

A Millennium II gas detection system is composed of a field mounted transmitter\controller and Millennium II series sensors which may be integrally mounted to the controller or remotely mounted as far as 2000 feet away.

The transmitter is certified for use in hazardous locations and is available as a single or dual sensor system. All operator controls including configuration and calibration can be accessed without opening the enclosure by using other communication devices and the attached magnet to actuate reed switches. If the area is non-hazardous and the enclosure (housing) is open then the operator may choose to use push-button switches and analog output test jacks on the face of the electronics module. Available outputs are: conventional 0.0 to 20mA analog, Analog/HART, electromechanical relays, solid-state relays or Modbus RTU digital.

A dual channel transmitter is available with "peak picking" functionality where there is only one analog output and this analog output follows the signal from the sensor that is responding to the highest gas concentration. This is useful in conserving analog input capacity on connected user equipment.

## ***THE MANUAL***

This manual has been designed to guide users through each procedure, ensuring that transmitters and sensors are configured, operated and maintained properly. Guidelines and warnings are included to ensure safe and proper functioning of the equipment. **The manual gives the overall operational and functional features of transmitters with sensors and may not have sensor specific information. Refer to sensor manuals for information specific to each sensor including detailed calibration instructions.** If you encounter any problems, see the troubleshooting section of this manual or contact factory.

### **Special conditions of use:**

#### **M2a-b-c, Millennium II Transmitter with enclosure:**

1. In order to maintain the performance of the system, the sensor to which this instrument is connected shall also comply with the requirements of EN 61779-1 and EN 61779-4

#### **TX-M2a-b, Millennium II Transmitter Electronics module only (w/o enclosure):**

1. If the Millennium II Transmitter is installed as Category 3 equipment, then it shall be installed in an Enclosure which maintains an ingress protection rating of IP54 and meets the enclosure requirements of EN 60079-0.
2. In order to maintain the performance of the system, the sensor to which the instrument is connected shall also comply with requirements of EN 61779-1 and EN 61779-4

## Enclosure Dimensions

The Millennium II Transmitter enclosure is available in Aluminum (AL6061) and Stainless Steel (SS316). Dimensions are in inches and millimeters.

Figure 1: Transmitter Enclosure Dimensional Drawing

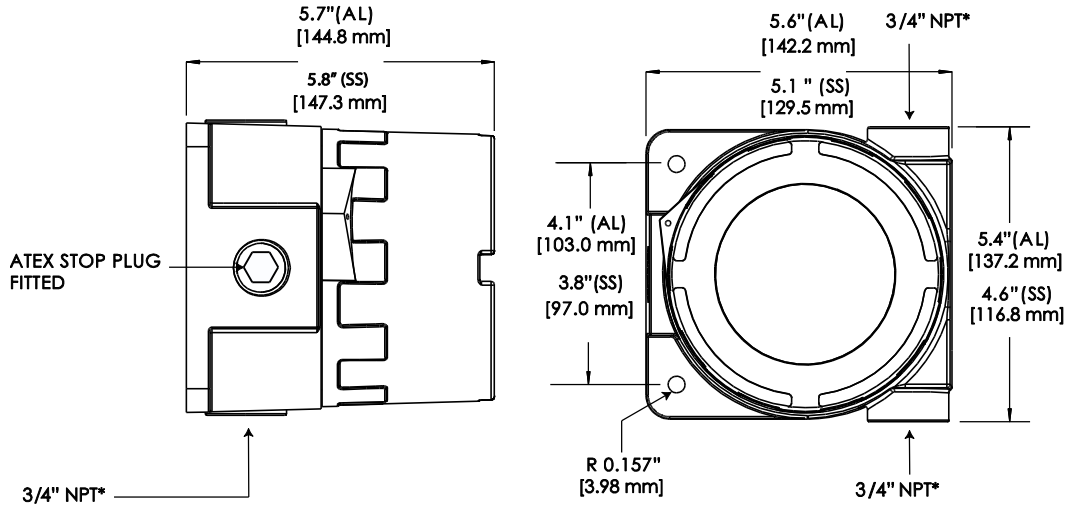

\* M20, 1/2" NPT, & 1/2" BSP threads also available

# SECTION 1: Installation

## 1.1 Unpack

Carefully remove all components from the packaging and check them against the enclosed packing list. Inspect all components for obvious damage such as broken or loose parts. If you find any components missing or damaged, notify the representative or Net Safety Monitoring, immediately.

## 1.2 Mounting

Ensure transmitter and sensor are securely mounted, taking into consideration all requirements. Sensors may be installed directly to transmitters or remotely using a Certified Net Safety junction box. See Figure 11 when mounting sensor remotely.

### 1.2.1 Transmitter Orientation Option

Depending on the installation and mounting requirements, the transmitter enclosure (housing) may be mounted in different orientations as seen in Figure 2. To accommodate the different mounting orientations, the electronics module can be rotated inside the transmitter enclosure. See Section '1.2.3 Rotating electronics module relative to enclosure and conduit entries' and Figure 4.

**NOTE:** Ensure the orientation allows proper wiring and adequate wire length inside the transmitter enclosure.

**Figure 2: Different enclosure orientations**

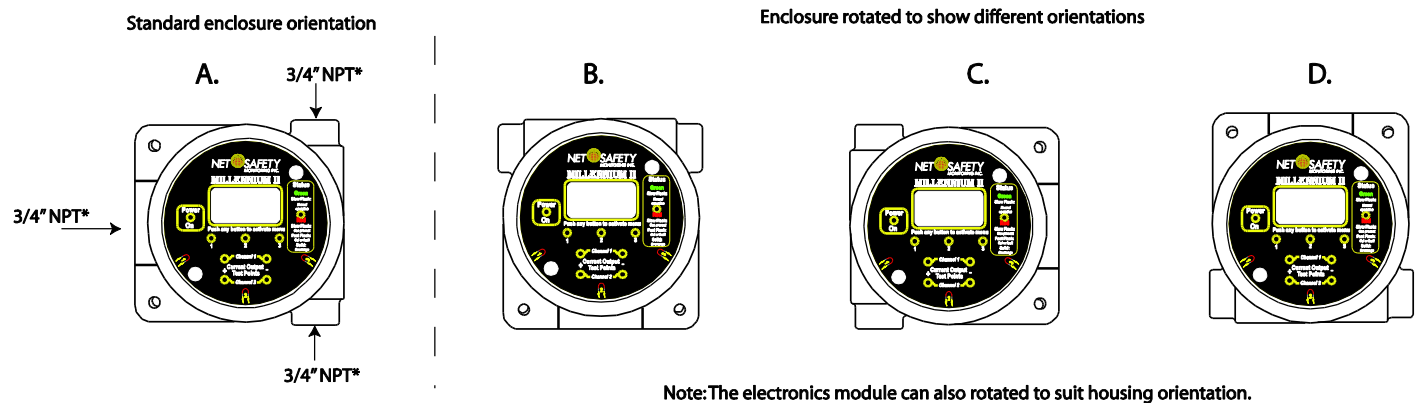

When determining suitable enclosure orientation for specific application, installers should observe all local regulations and guidelines for mounting enclosures.

\* M20, 1/2" NPT, & 1/2" BSP threads also available

## 1.2.2 Transmitter electronics module and Relay options

The transmitter electronics module may be equipped with 4 electromechanical relays or 4 solid-state relays which are mounted to the main terminal board via plastic standoffs. Relay boards are field replaceable by simply unlocking the plastic standoffs with a small flat head screw driver. Remove relay board after unlocking standoffs, insert the replacement relay board, and then lock the plastic standoff with the screw driver. See Figure 3 for relay board description.

**Warning** ⚠ Before wiring or replacement of relay boards, ensure that the power to transmitter is switched off. Do not open the transmitter enclosure in a classified area.

**Warning** ⚠ Avoid touching electronic components, as they are susceptible to electrostatic discharge (ESD). Refer to Appendix A, “Electrostatic Sensitive Device (ESD)”.

Figure 3: Board assembly diagram

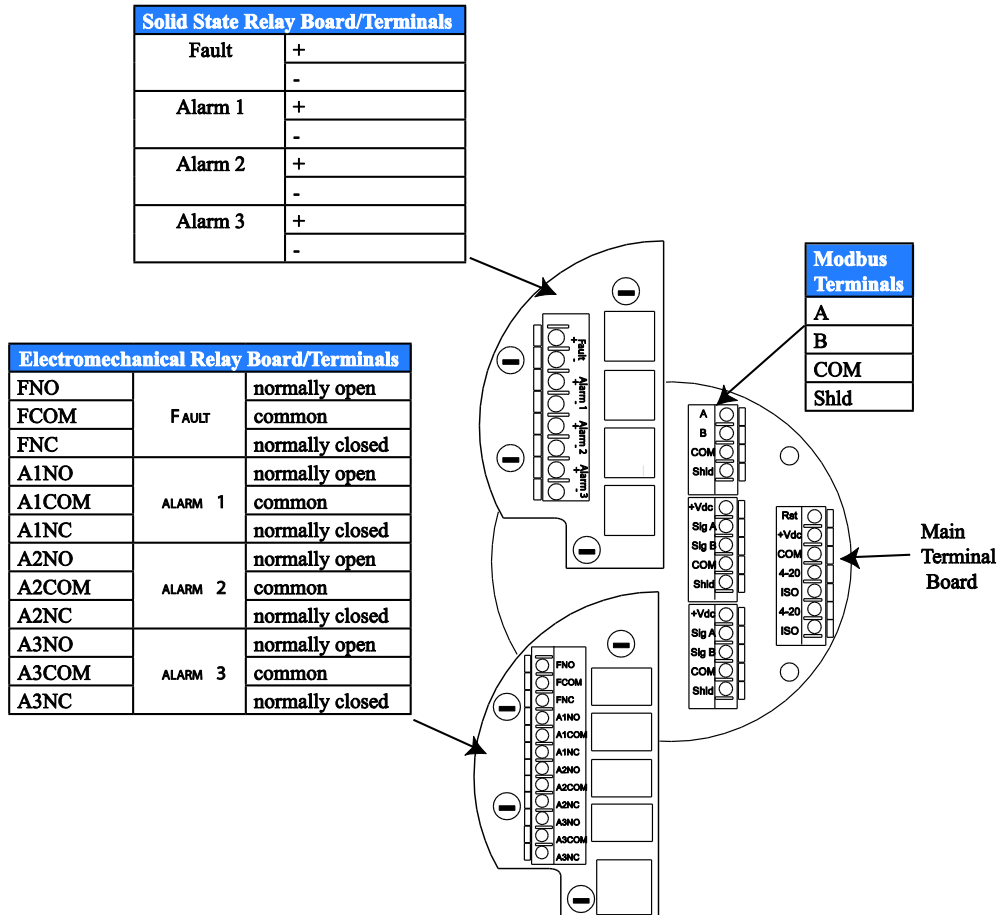



### 1.2.3 Rotating electronics module relative to enclosure and conduit entries

The electronics module consists of the relay board and faceplate (Display/CPU assembly) with main terminal board. To rotate the electronics module, follow these instructions:

1. Turn off power to transmitter and ensure area is de-classified.
2. Remove the enclosure cover.
3. Unscrew both the locking knobs and free from two metal standoffs.
4. Lift transmitter faceplate from enclosure.
5. Disconnect existing wiring.
6. Unscrew the two metal standoffs using a 1/4" hex tool.
7. Carefully remove the electronics module.
8. Rotate the electronics module to desired position.
9. Align metal standoffs with the mounting holes of the electronics module and enclosure base.
10. Insert metal standoffs in the appropriate mounting holes.
11. Tighten metal standoffs with 1/4" hex tool to secure electronics module.
12. Reconnect wiring.
13. Replace faceplate, then fit and hand tighten locking knobs to metal standoffs by turning clockwise.
14. Replace enclosure cover.

**Warning** ⚠ Before wiring or rotating electronics, ensure that the power to transmitter is switched off. Do not open the transmitter enclosure in a classified area.

**Warning** ⚠ Avoid touching electronic components, as they are susceptible to electrostatic discharge (ESD). Refer to Appendix A, "Electrostatic Sensitive Device (ESD)".

Figure 4: Rotating Electronics module

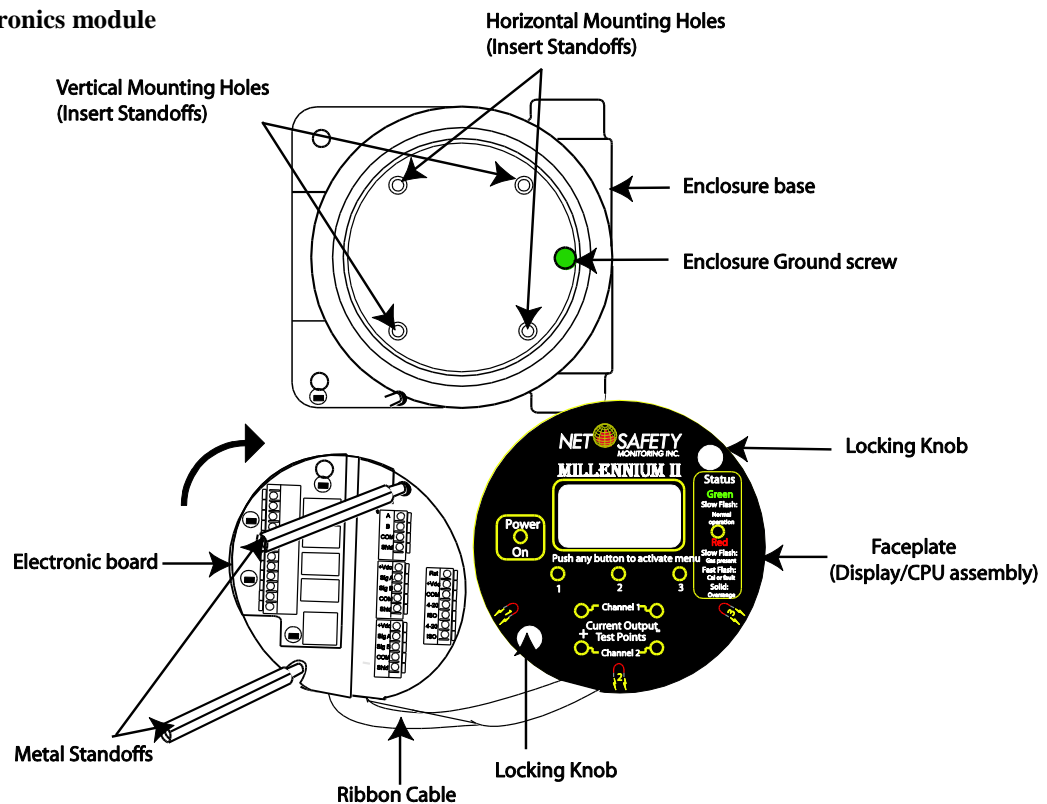

**Note:** To access enclosure grounding screw, remove the electronics module by following steps 1-7 above.

## SECTION 2: Wiring and installation

### 2.1 Field Installation

**Warning** ⚠ Wiring codes and regulations may vary. ATEX requires that supply connection wiring must be rated at least 5°C above the maximum ambient temperature of 85°C. Wiring must comply with all applicable regulations relating to the installation of electrical equipment in a hazardous area and is the responsibility of the installer. If in doubt, consult qualified personnel before wiring the system.

**Warning** ⚠ Do not open the transmitter enclosure in a classified area (Do not open when an explosive atmosphere may be present).

#### Guidelines

- The safety ground connection of the transmitter is a Green screw found in the enclosure. See Figure 4 for Ground screw location. **Note:** The electronics module has to be removed to access Ground screw. Follow steps 1-7 under Section '1.2.3 Rotating electronics module relative to enclosure and conduit entries', when removing electronics module.
- If the 4-20mA signal is not used, connect a jumper between the 4 – 20mA terminal and the Common terminal to allow analog current levels to be monitored at the Test Jacks on the faceplate.
- The use of shielded cable is highly recommended for signal, input, output and power wires. Refer to Section '2.1.2 Cable choice and guidelines' for recommended cable to help eliminate interference caused by extraneous electrical or electromagnetic 'noise'. To meet IEC 61000-1 and IEC 61000-4 EMI requirements, follow the recommendations listed under Section '2.1.2 Cable choice and guidelines'.
- In applications where wiring is installed in conduit, conduit must not be used for wiring to any other electrical equipment.
- For effective communication, Net Safety limits sensor separation to 2000 feet using 16AWG wires.
- Modbus RS-485 connection 2-wire mode, multipoint serial line available. Up to 247 addresses allowed.
- When developing a RS-485 chain of devices, the last device in the chain requires an end of line termination resistor (120 Ohms).
- Transmitter connector terminals accommodate wire from 14 to 20 AWG wires.

#### 2.1.1 Seals

**Warning** ⚠ The use of conduit wiring seals is recommended to protect the system against water ingress, and equipment should be installed according to local electrical codes. Seals are especially recommended for installations that use high-pressure or steam cleaning devices in proximity to the transmitter and/or sensor. The cementing material used on the Millennium II sensors is suitable for an operating temperature range of (-55°C to +85 °C).

#### Guidelines

- It is recommended that explosion-proof drains and conduit breathers be used. In some applications, alternate changes in temperature and barometric pressure can cause 'breathing' which allows moist air to enter and circulate inside the conduit. Joints in the conduit system are seldom tight enough to prevent this 'breathing'.
- Threaded connections on the enclosure between the enclosure and conduit pipe need to be sealed with thread tape, such as Teflon tape, or something similar.
- Hydrophobic filters (IPF-001) may be used to protect sensors from water.

- It is the responsibility of the installer to install conduit seals where necessary, and to design conduit runs to ensure that condensation does not accumulate and collect inside the enclosure.

### **2.1.2 Cable choice and guidelines**

Radio Frequency Interference (RFI) can be caused by nearby electrical devices (transformers, high voltage equipment) as well as handheld communications devices/radios, which when activated, may impede the proper functioning of the transmitter and sensor. Selecting the right instrumentation cable and making proper grounding connections within the junction box will reduce or eliminate interference. Visible symptoms of Radio Frequency Interference (RFI) include inconsistent, incorrect and erratic LEL and PPM readings.

#### **Important Wiring Guidelines**

Fire and gas detection instruments are an important part of a safety alarm and shutdown system. The system is composed of:

- detection instruments
- customer connected equipment
- wiring

Net Safety designs and manufactures its detection equipment under rigid quality control management systems and makes every effort to design for the harshest of industrial environments. The other components of the system – the customer-connected equipment and wiring – are also important contributors to the overall quality and performance of the safety system.

It is important to implement wiring that ensures the reliability and integrity of the safety system. Field wiring practices and the choice of cable type specified vary from project to project. Poor practices and choices are often found to be the source of unwanted system disruptions. Radio Frequency Interference (RFI) and Electro-Magnetic Interference (EMI) are usually very powerful disruptive forces in industrial facilities and these forces act upon the system through the wiring.

Follow the wiring specifications and guidelines in this manual carefully. The cable used should be a very high quality instrument grade, certified for the application conditions, consisting of a rugged protective outer jacket, an overall electrical shield of fine braided copper or metallic foil, and internal pairs or triads of foil shielded copper wire of suitable gauge for the power conducted over the specified length.

The shields must be electrically continuous from the instrument junction box through other junction boxes and finally to the connected equipment. The shield must be connected to a suitable ground sink as specified in the instrument manual in order to protect the system from electrical disturbances.

#### **Recommended cable and guidelines**

The type of cable and shielding practices are especially important when sensor is separated from transmitter via junction box. Net Safety recommends using CSA armored instrumentation cable (ACIC 2PR 16AWG, 300V, ISOS, PVC) when rigid (steel) conduit is not used. See Figure 5. This cable should be used between the PLC/PANEL/DCS and the Millennium II Transmitter, as well as between the Millennium II Transmitter and junction box.

#### **Additional notes:**

In general, communication cables and power cables should not run in parallel for any significant length, and should not be carried in the same cable tray. Through inductance, high currents in power cables can induce significant 'noise' in communication cables running parallel alongside power cables.

**See cable preparation procedure on next page.**

**Armored Cable preparation procedure:**

1. Prepare the armored instrument cable as illustrated in Figure 5 and follow all assembly and/or preparation instructions provided by the cable and/or cable gland manufacturer.
2. Install cable gland and reducer onto the cable.
3. Ensure four (4) inches of wire length is available for connecting to terminals inside the junction box.
4. Use a small flat head screw driver when connecting wires to connector terminals. See Figure 6.
5. Connect sensor wires to the appropriate terminals. See Figure 5C, Figure 9, Figure 12 and Figure 13.

**Figure 5: Cable preparation**

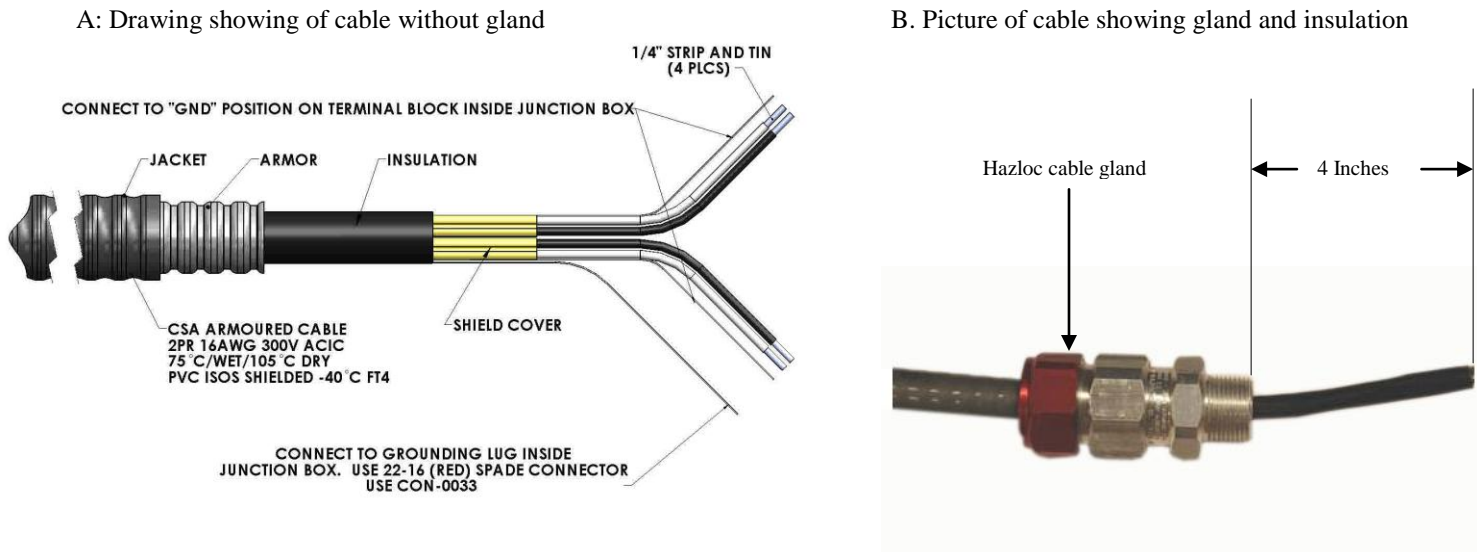

C. Picture of cable wired to junction box and sensor

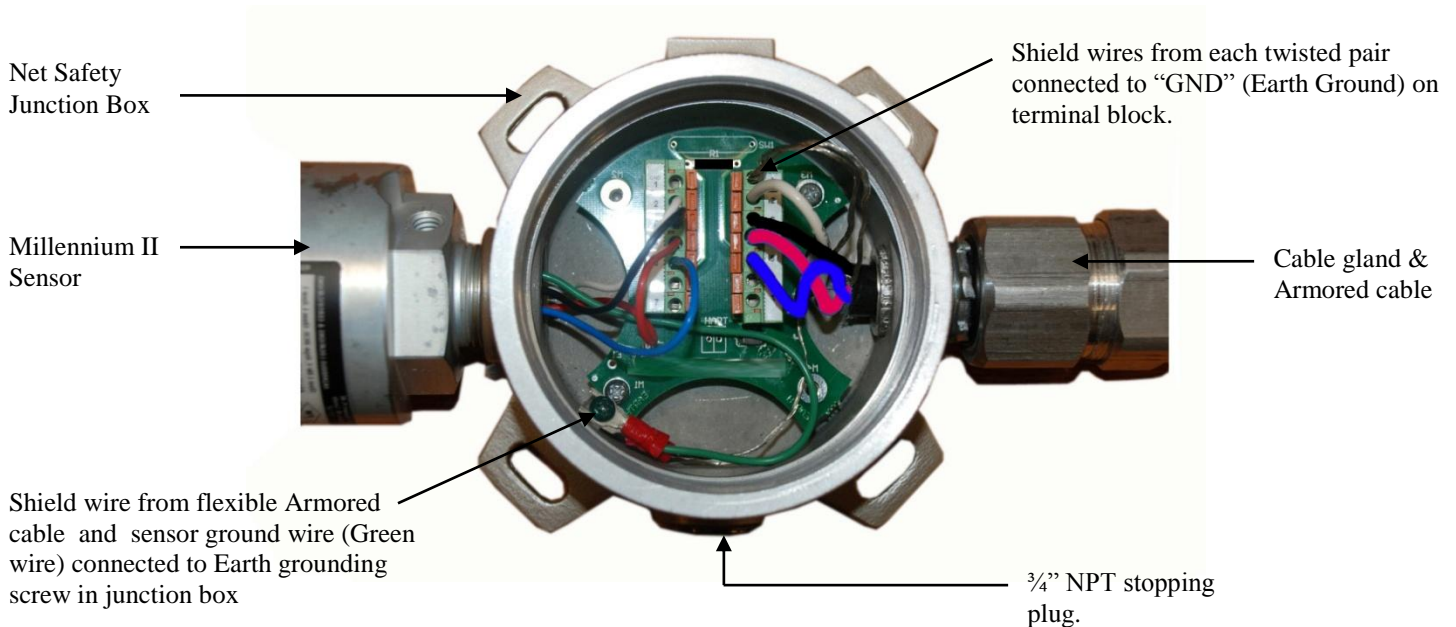

**Note:** If required, use cable glands which have been approved for hazardous locations.

**Warning** ⚠ Before wiring, ensure that power to transmitter is switched off.

When connecting cable wires, use a small screwdriver to gently press down and hold the spring connector open. Insert the appropriate wire into the open connector hole, releasing the screwdriver to secure the wire. See Figure 6.

Figure 6: Connecting wires

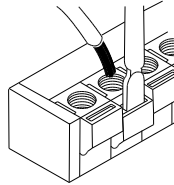

**Warning** ⚠ Avoid touching electronic components, as they are susceptible to electrostatic discharge (ESD). Refer to Appendix A, “Electrostatic Sensitive Device (ESD)”.

### 2.1.3 Analog output, isolated supply, non-isolated supply and jumper configuration

The analog output may be powered from the main instrument power supply or a separate, independent power supply in which case an isolated wiring configuration is necessary.

To set a Non-isolated or Isolated current output, simply move the Jumpers/shorting jacks (JP3 and JP4) to either the Non-isolated or Isolated current position. **For Non-isolated current output, ensure pins 3 & 2 at JP3 & JP4 location on the main terminal board are jumpered (shorted).** Factory standard models ship with jumpers at JP3 & JP4 in the Non-isolated current output position (**default position**).

**For Isolated current output, pins 1 & 2 at JP3 & JP4 should be jumpered (shorted).** Note that **JP3 is for configuring channel 1** and **JP4 is for configuring channel 2**. Jumpers and pins are located next to the Power and 4-20 output terminals on the main terminal board. See Figure 7, also Figure 12 & Figure 13 for reference.

Figure 7: Non- Isolated and Isolated current jumpers

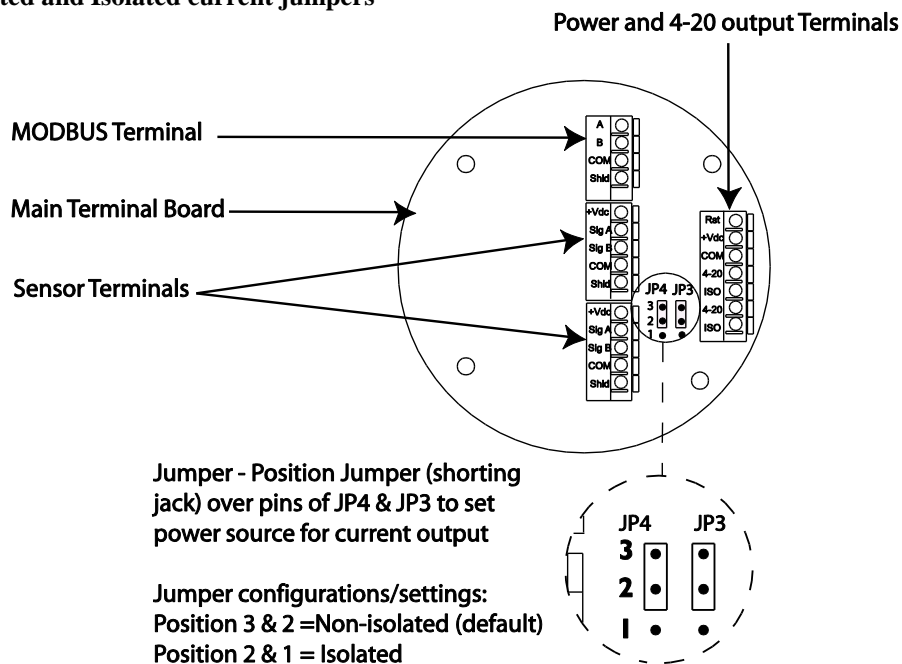

**Warning** ⚠ Always ensure that JP3 and JP4 jumpers are in the correct position depending on the current output configuration chosen.

## 2.1.4 Remotely mounted sensors jumper configuration

Sensor separation from the transmitter may extend up to 2000 feet in which case a junction box is required. When mounting sensor remotely (separating sensor from transmitter), Jumpers JP1 and JP2 should be installed over the pins. Jumpers and pins are located on the main terminal board near the sensor terminals. **JP1 is for channel 1 and JP2 is for channel 2.** Refer to Figure 8.

Figure 8: Separation Jumpers positions

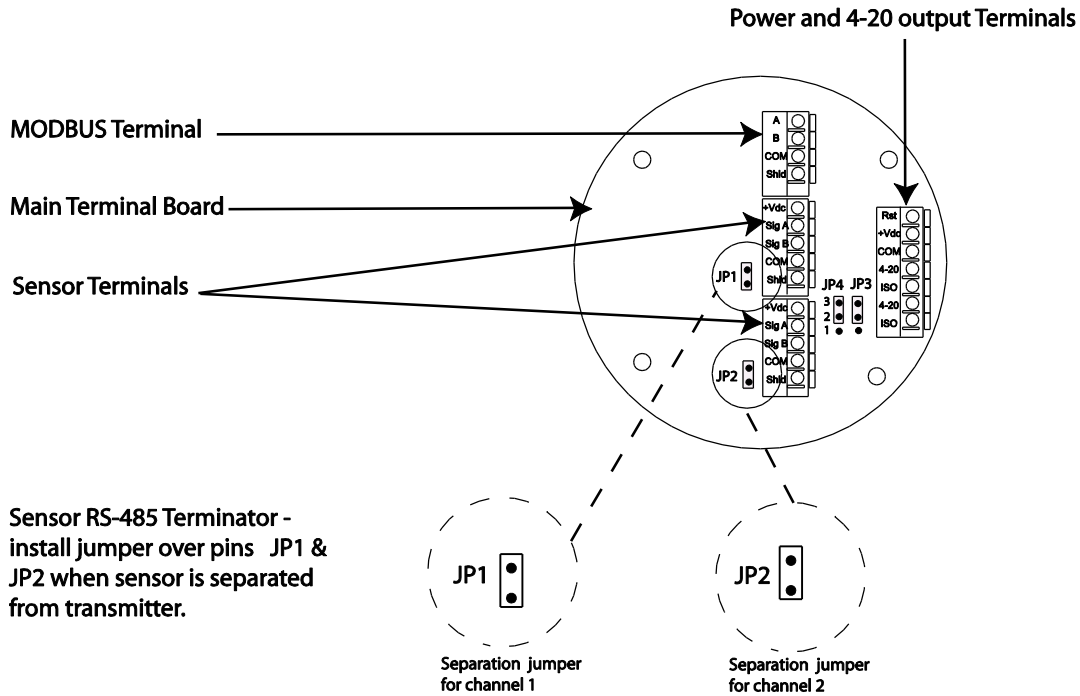

**Warning** ⚠ When separating sensor and transmitter, install JP1 and JP2 over pins.

## 2.1.5 Sensor and Transmitter terminals

**Warning** ⚠ Before wiring, ensure power to the unit is switched off. Connect the sensor wires to the sensor terminals of the transmitter and connect the transmitter's power and output terminals to the wiring leading to the Power source/panel. Refer to the configuration tables below for sensor as well as transmitter power and output terminal designations.

**Table 1: Sensor and Transmitter Terminals**

Sensor Terminals		Transmitter Power Terminals	
Sensor Wires	Transmitter Sensor Board Terminal designation	Transmitter terminal designation	Function
White	+Vdc(from transmitter)	RST	Remote Reset
Red	SigA	+Vdc(10.5-32)	Power(+)
Blue	SigB	COM	Power(-)
Black	Com	4-20(CH1)	Current loop output
Green	Earth Ground	ISO(CH1)	+Vdc isolated 4-20 power
		4-20(CH2)	Current loop output
		ISO(CH2)	+Vdc isolated 4-20 power

**Figure 9: Sensor wiring and terminal connections**

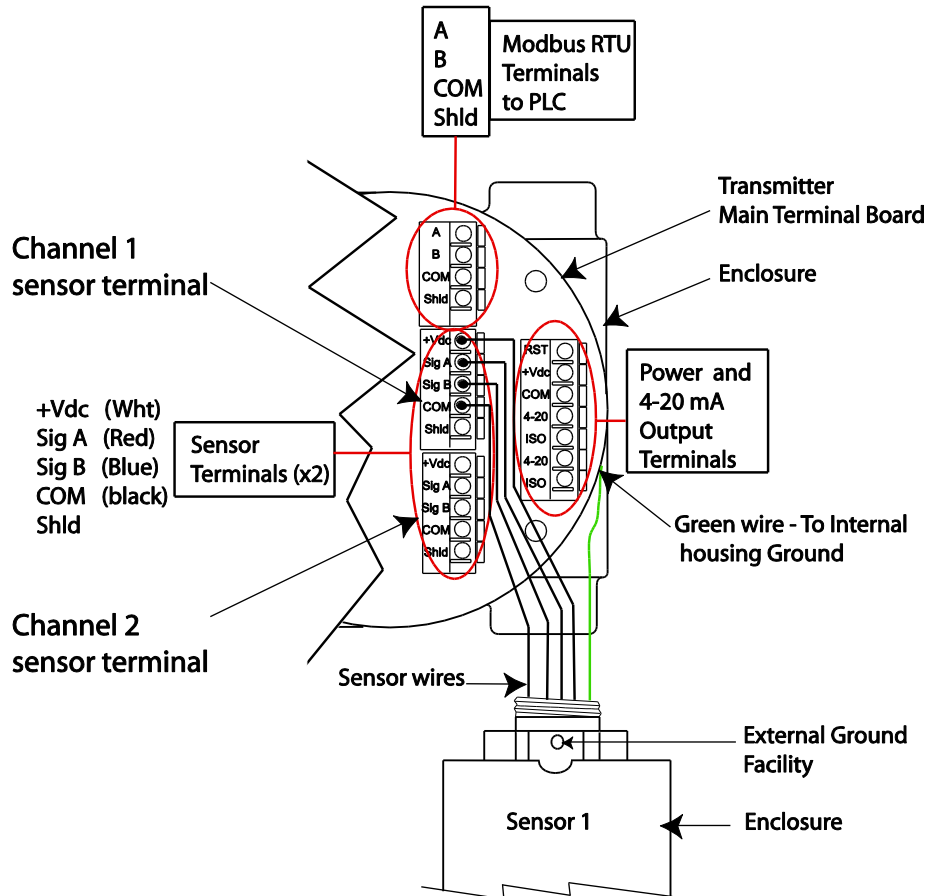

## 2.1.6 Remote Reset

If the alarm relays are configured for latching operation it may be desirable to reset latched alarms from a remote location. In this case a normally open, momentary push-button switch may be connected across terminals RST and COM.

Figure 10: Remote Reset wiring

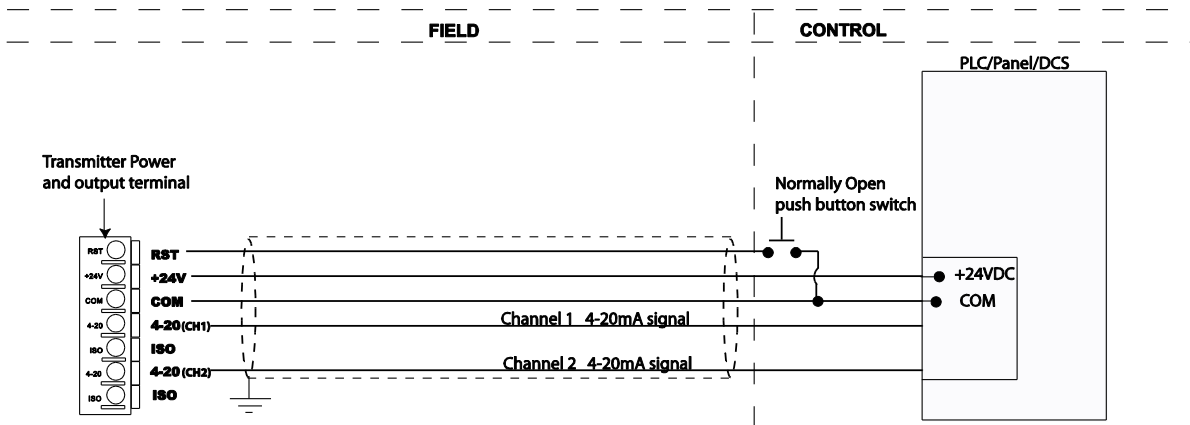

## 2.1.7 Sensor Separation/ Remote mounting of sensor

When necessary to mount sensor remotely (separated from transmitter) by way of junction box and conduit, it is important that the installer follow the necessary requirements and guidelines relating to sensor separation and cable selection. See Figure 11 for typical remote mounting of sensor. Also refer Section '2.1.2 Cable choice and guidelines' for cable selection and wiring guidelines.

When sensors are being mounted remotely, **consult the multi-purpose junction box manual (MAN-0081)** for wiring instructions. Always ensure that the transmitter is supplying 10.5 - 32Vdc across the sensor power terminals (Vdc + and Com (-) ) of Net Safety junction box (JB-MPD-A/S).

The maximum distance between the sensor and transmitter is limited by the resistance of the connecting wiring, which is a function of the gauge of the wire being used. For effective communication, Net Safety limits the separation distance between sensor and transmitter to 2000ft using 16 AWG wire. See Appendix B for information on wire gauge and resistance.

Figure 11: Sensor separation/remote mounting of sensor

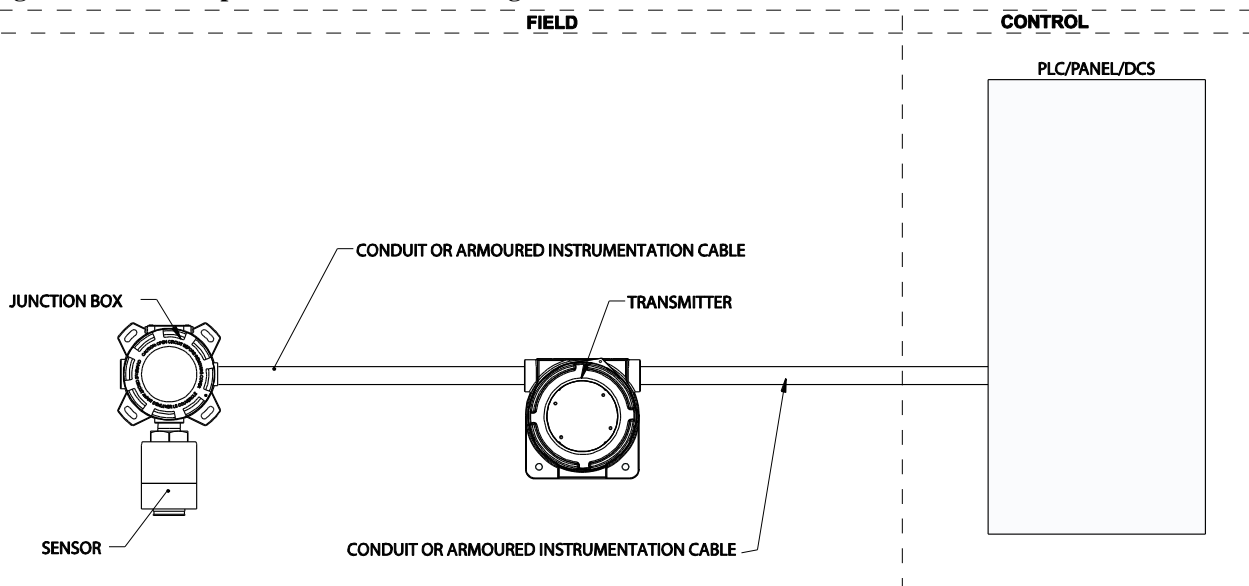



## 2.1.8 Wiring drawings

Wiring drawings show general ways in wiring the system for analog signal output. Consult qualified personnel on specific wiring requirements.

Figure 12: Non-isolated terminal connection

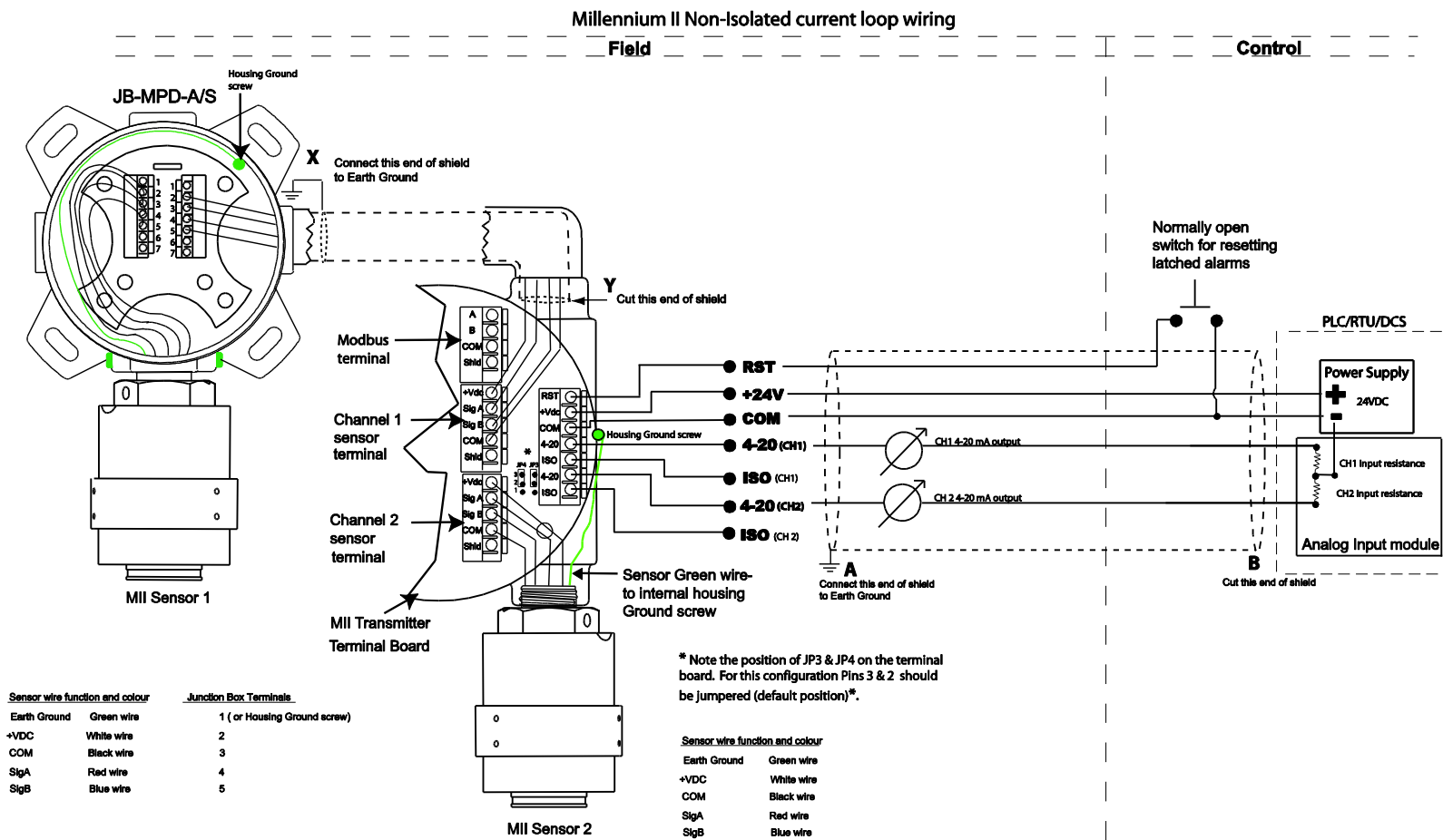
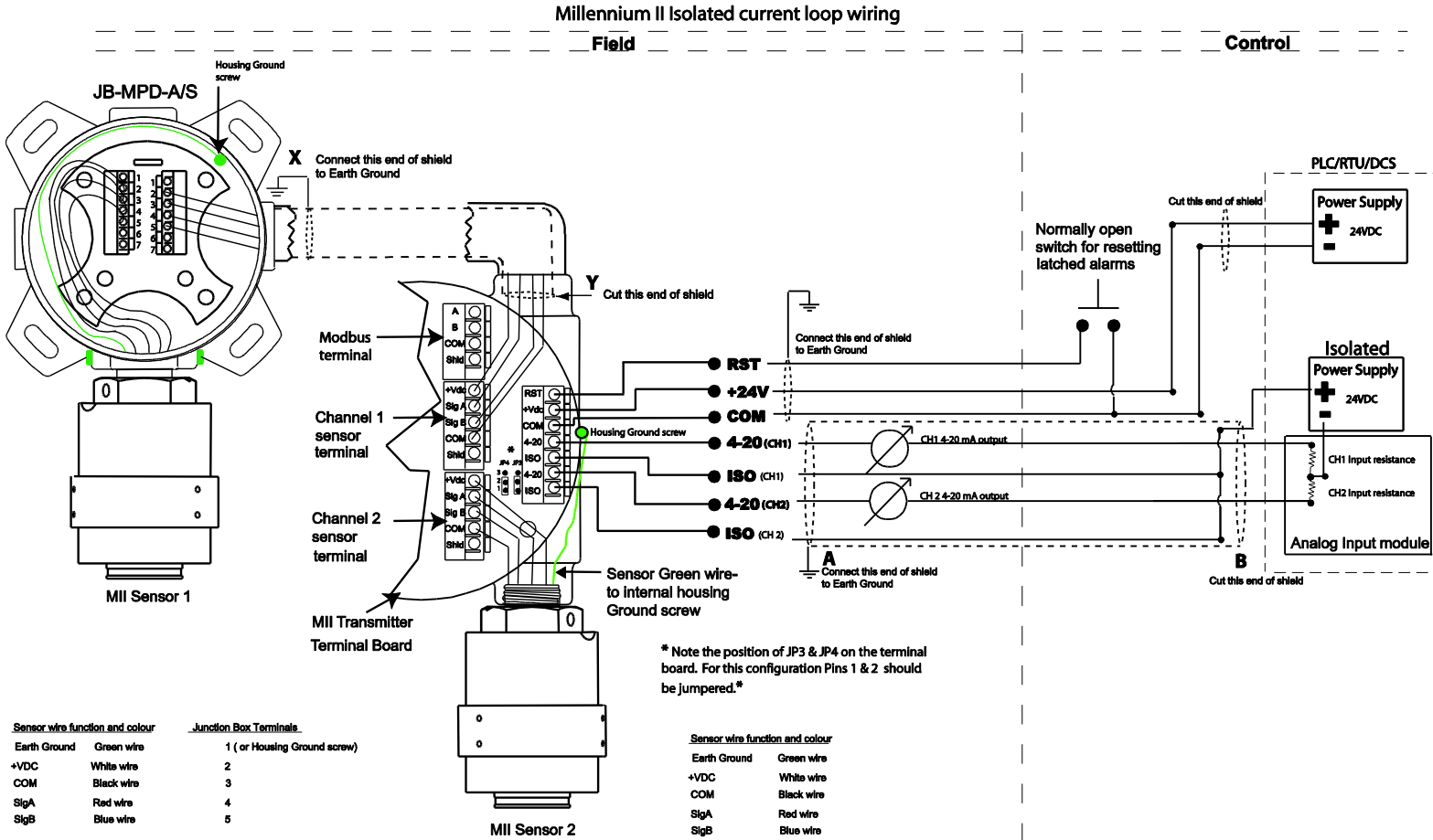



Figure 13: Isolated terminal connection



## 2.1.9 Installation Checklist

Prior to operation, it is important to do the following checks.

- Ensure transmitter and sensor are properly and firmly mounted.
- Ensure that the enclosure certified stopping plug is tightened to unused conduit entry/opening, to maintain ingress protection and flameproof type protection.
- Ensure transmitter and sensor are not being obstructed; transmitter and sensor are accessible and target gas is not inhibited from reaching sensor.
-  Remove sensor red protective plastic cap.
- If hydrophobic filters (IPF-001) are being used, check for damage or debris. See the IP 66/67 filter Instruction guide (MAN-0109) for instructions.
- If calibration cups (splash guards) are fitted to sensor, ensure a snug fit.
- Ensure adherence to applicable local guidelines and requirements on wiring and sealing of equipment in hazardous and non-hazardous areas.
- Ensure that proper shielding and grounding practices are adhered to, and local codes are being followed.
- Check system operational voltage and conditions. See Table 1 and Appendix C.
- Check wiring at all termination and junction points; wiring at transmitter terminals, junction box and at power supply. Refer to Table 1, also Figure 7, Figure 8, Figure 9, Figure 12 and Figure 13

## SECTION 3: Transmitter and faceplate description

### 3.1 Transmitter Power Up

After power is applied to the transmitter, a warm-up routine will begin, the duration of which depends on the sensor type. The display will indicate the sensor warming up and the Status LED will flash Slow Red and current output will be 3.0mA. After the warm-up period, the transmitter will enter normal operation and the screen will display: **“Channel 1 00 %LEL (or PPM), Channel 2 00 %LEL (or PPM).”** For dual channel models either channel can be disabled if not in use. If a channel is disabled, the screen will display: “Disabled” for that particular channel. The enabled channel analog output will be to 4.0 mA during normal operation.

Figure 14: Faceplate description

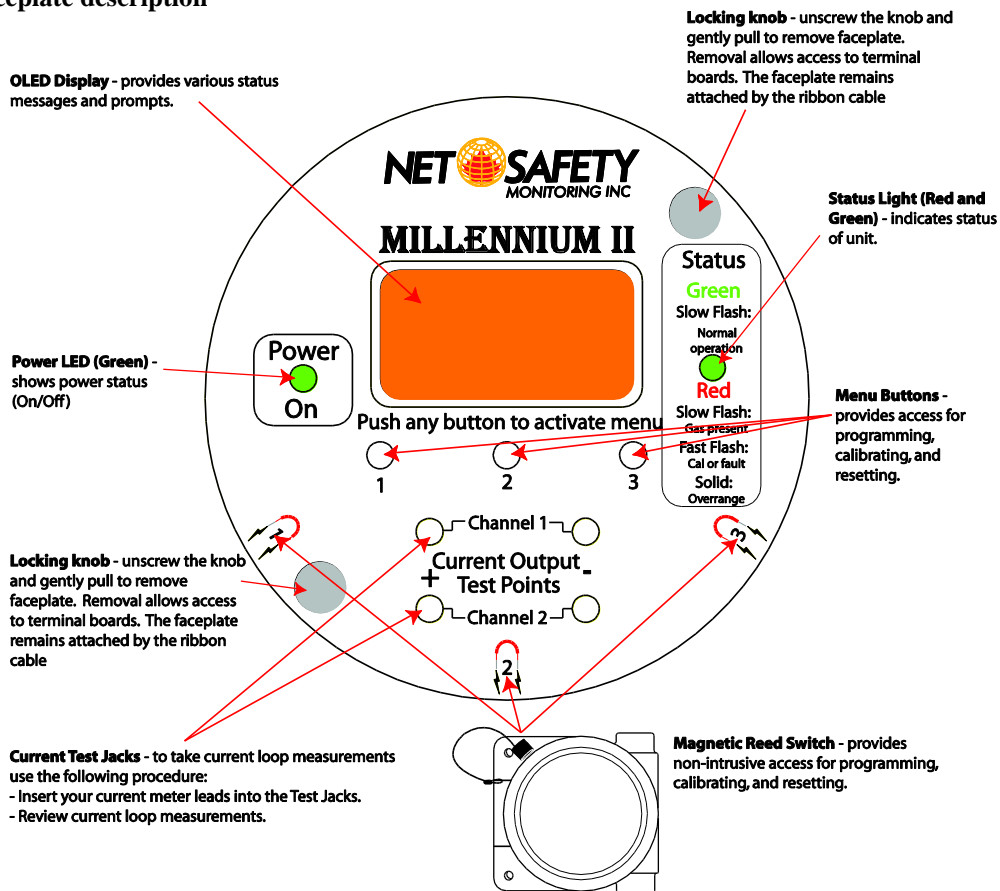

**Note:** A slow flash is defined as the Status LED being ‘ON’ for 50 milli-seconds and ‘OFF’ for 1 second, while a fast flash is the LED being ‘ON’ for 250 milli-seconds and ‘OFF’ for 250 milli-seconds and a very fast flash is the LED ‘ON’ for 50 milli-seconds and ‘OFF’ for 50 milli-seconds.

### 3.2 Display

The Millennium II is equipped with an Organic LED (O LED) display. It allows the user to see the concentration of gas present for each individual channel and the various options offered. The display has a wide temperature rating and will operate well in lowly lit conditions. In order to extend the life of the display, a screen saver is enabled if the menu is not in use. To exit the screen saver mode, move the magnet close to any of the three Reed switch locations (**8 o’ clock, 6 o’ clock or 4 o’ clock position**). See Figure 14 and Figure 15.

### 3.3 Status LED

The Status LED can be solid Red or Green, or flashing Red or Green to indicate various states of the transmitter and sensor. Refer to “Sensor Status Registers, Status LEDs, Current Loop, and Display Messages”.

### 3.4 Current loop measurement (Test jacks)

For convenience, a pair of test jacks for each analog output is provided on the front face of the display module. Attach mA meter probes to these jacks to check loop current without opening the circuit to insert the meter. Refer to Figure 14 and Figure 15 for test jacks location.

**Warning** ⚠ Do not open the transmitter enclosure in a classified area.

### 3.5 Menu buttons and access

The main menu can be accessed in two ways: Intrusive (opening the enclosure and pressing menu buttons) and Non-Intrusive (keeping the enclosure closed and using the magnet and reed switches).

#### 3.5.1 Intrusive Access

The menu buttons provide access to the Millennium II’s Main Menu options allowing the user to review and configure existing options under sub menus and perform calibration. **There are three visible main menu buttons that are located directly under the display screen. They are designated ‘1’, ‘2’ and ‘3’.** See Figure 14 and Figure 15.

#### 3.5.2 Non-Intrusive Access/Magnetic Reed switch Access

Accessing the main menu and making a selection can also be done via an attached magnet and Reed switches. The Reed switches are located in the *8 o’clock*, *6 o’clock* and *4 o’clock* positions on the face plate and indicated by horse shoe shape print magnets. To select a Reed switch, place and hold the magnet close to the transmitter enclosure at *8, 6* or *4 o’clock* position. See Figure 14 and Figure 15.

**Note:** Menu buttons and reed switches provide the same functions. The term ‘switch’ is used throughout to represent menu buttons and reed switches.

Figure 15: Switch positions

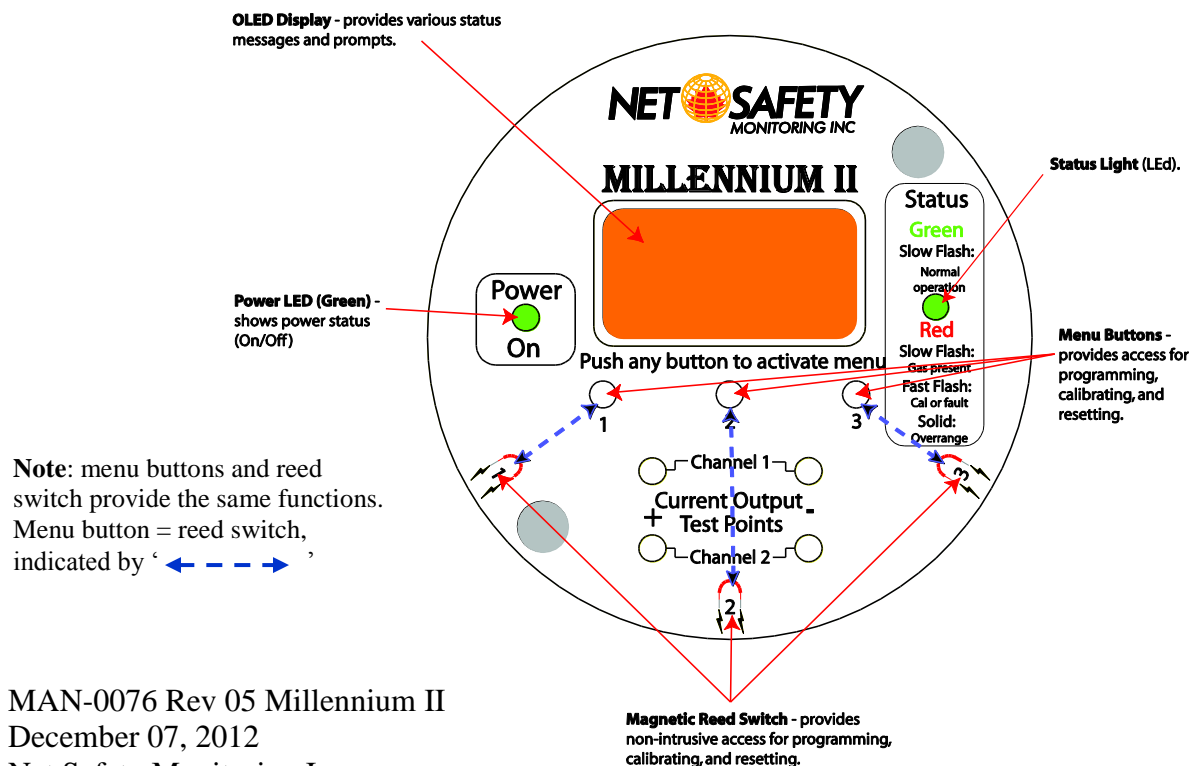

## SECTION 4: Operation

### 4.1 Menu options

The main menu provides access to various functional settings/options, as seen in the Table 2 below. Each menu option has a submenu, whereby configuration is done.

**Table 2: Main menu options**

Calibrate Sensor	Select Display Language	Self-test Relay
Enable/Disable Channels	Modbus Setup	Sensor Upper Limit(Range)
Set Alarm Level	Setup Current Date	Select Gas Type
Set Relay Option	Setup Current Time	Cal. Gas Value
Relay Assignment	View Events Log	Serial Number and Firmware version
Relay Alarm Mode setting	Manual Reset	Exit

### 4.2 Navigating main menu

Navigation through the menu options is done by activating *menu button 1 or 2*. The same function is provided using magnet to select *Reed switch 1* (indicated by printed magnet in the *8' o clock* position on the face plate) or *Reed switch 2* (indicated by printed magnet in the *6' o clock* position on the face plate).

1. Enter the main menu, either intrusive or non-intrusive (using the magnet), by selecting/activating any button then select “yes” by using *switch 1*.
2. The message “Calibrate Sensor?” will be displayed.
3. Activate up-down buttons (*switch 1*) or (*switch 2*) to scroll/navigate through main menu options.
4. Select/activate the enter key (*switch 3*) to display sub menu. See
5. Figure 16 and Figure 17.
6. To exit the main menu, continue using the navigation keys (up-down keys) and select “Exit” with enter key at each menu stage (sub menu and main menu).
7. The main menu will be exited automatically if no option is selected; it takes 50 seconds to exit to each of the previous options or stage entered. If left untouched, this continues until the main menu is fully exited.

**Figure 16: Main menu navigation**

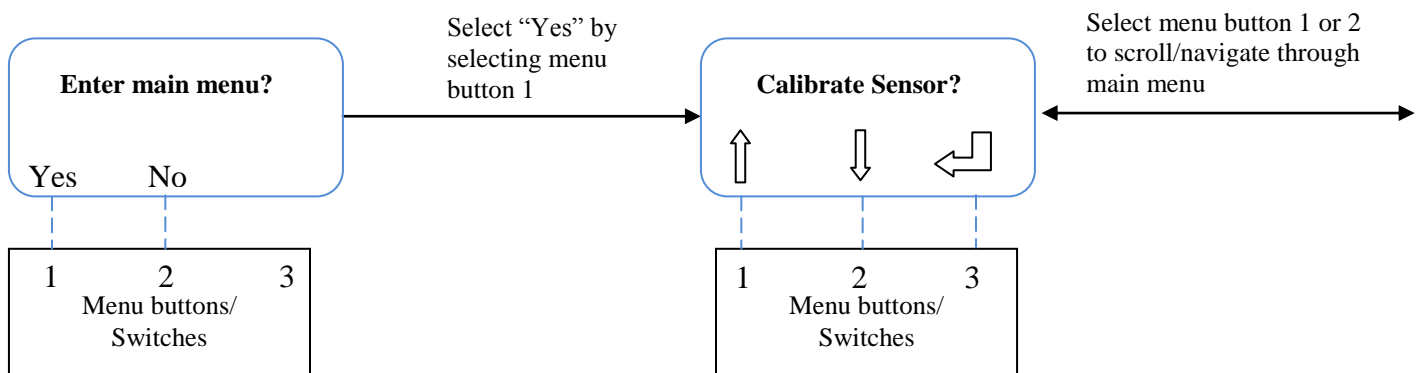

**Figure 17: Menu structure flow chart**

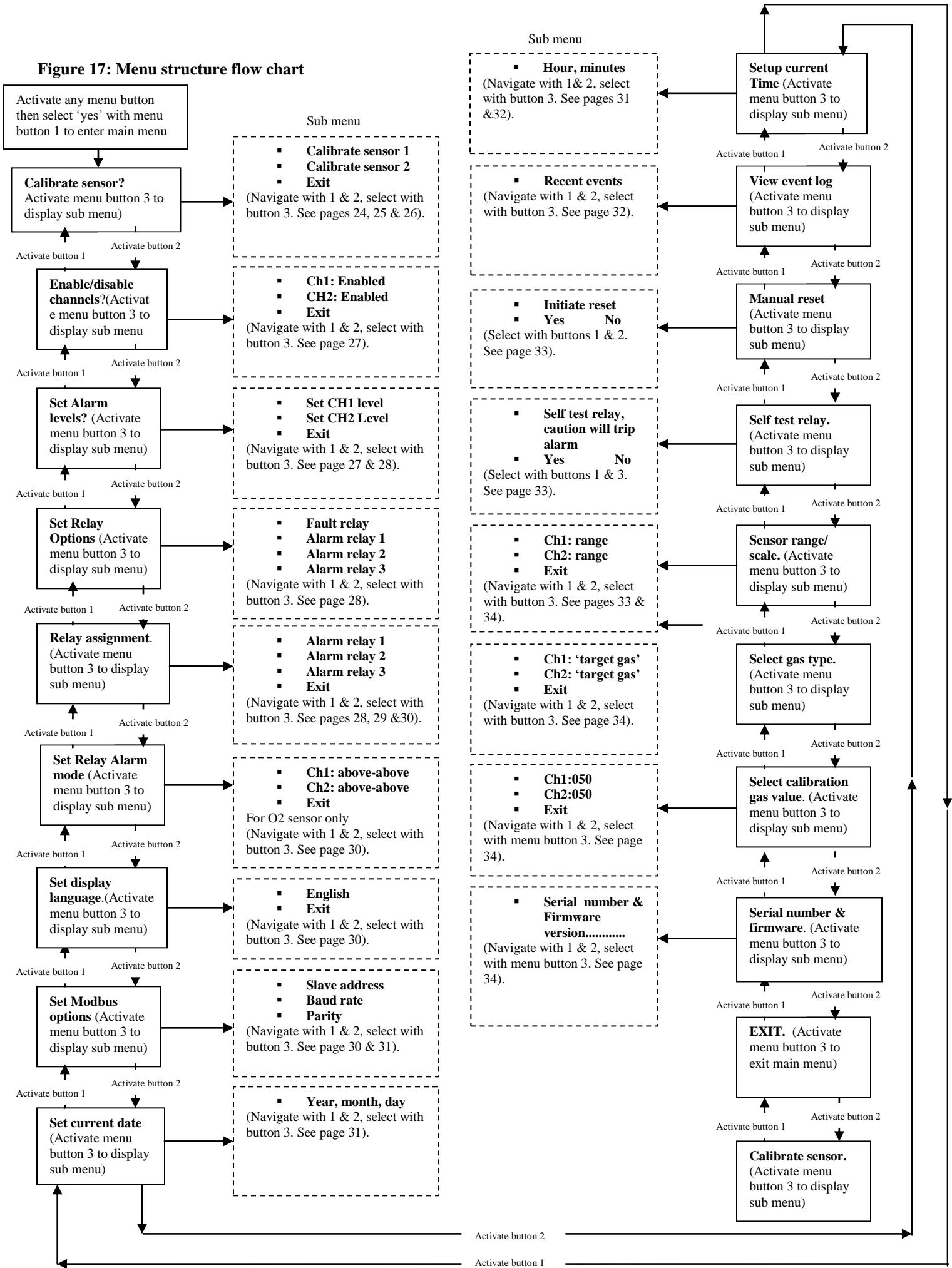

#### 4.2.1 Full calibration (Normal calibration) procedure

Prior to attempting calibration read and understand the calibration procedure below. Also see Figure 18 for additional reference.

The following calibration procedure should be followed to ensure an accurate correlation between the output signal and the gas concentration. For accurate performance, the Millennium II is calibrated using 50% span gas. The transmitter will however, allow some flexibility in the use of calibration gas with some sensors; calibration gas outside of 50 % span (10% - 60% span gas) will be allowed on specific sensor models (see specific sensor manual for details). The calibration gas value can be chosen by selecting it under “*cal. gas value*” in the main menu. A full calibration will take approximately 5 minutes to complete.

Ensure the transmitter is functioning properly as indicated by the status LED and current output.

1. Enter the main menu by selecting/activating any key to get the “*enter main menu*” prompt, then activate **switch 1** to select “*yes*”.
2. When “*Calibrate Sensor?*” is displayed, activate the enter key (**switch 3**).
3. When “*Calibrate Sensor #1?*” is highlighted, activate the enter key (**switch 3**) if this is the sensor to be calibrated.
4. If sensor #2 is to be calibrated, select the down arrow key (**switch 2**) to scroll to “*Calibrate Sensor #2?*”
5. Select the desired sensor to be calibrated (1 or 2) by activating the enter key (**switch 3**).
6. Select “*YES*” with **switch 1** to confirm the selection, and then apply clean air (zero gas) from canister when “*Apply Clean Air*” is displayed. Ensure no contaminant gases are around if ambient air is being used.
7. Select “*Z & Span*” using **switch 1** for normal (full) calibration. “*Setting zero*” will be displayed as the sensor is being zeroed.
8. Apply 50% calibration gas (\* or % *cal. gas value* chosen) when prompted.
9. The display will show “*Spanning*” with the gas value (%LEL or PPM depending on the sensor) as the gas is detected.
10. Remove the calibration gas when “*Remove Cal Gas*” is displayed.
11. “*Cal Complete*” will be displayed when calibration is complete.
12. Apply zero gas (clean air) to purge system. This is particularly important when using long tubing.

\* **Note:** Selectable calibration gas value (% cal. gas value) is only available for some sensor types.

**Warning**  Always apply test gas after any calibration to verify accuracy; do a bump test after calibration. When applying test gas, make sure the system is bypassed to avoid unwanted shutdowns.



#### 4.2.2 (Cont'd) Zero calibration option

The “**Zero**” calibration option is selected if the sensor is only being zeroed (this not a complete calibration) It does not require the application of span gas, as only the sensor’s zero point is adjusted. Ensure that no contaminants are present, if the surrounding air is to be used for Zeroing. If Zero calibration is needed, at step 7 above, select ‘Zero’ using *switch 3*).

**Warning**  Air movement, drafts and wind can cause dilution of calibration gas flow which can cause an erroneous calibration and inaccurate performance. To avoid this, use a Calibration Cup attached to the bottom of the sensor. The cup doesn’t have to be removed for normal operation. When the cup is in place, inject calibration gas at a rate of 0.5 – 1.0 liter per minute.

**Figure 18: Calibration Flow chart**

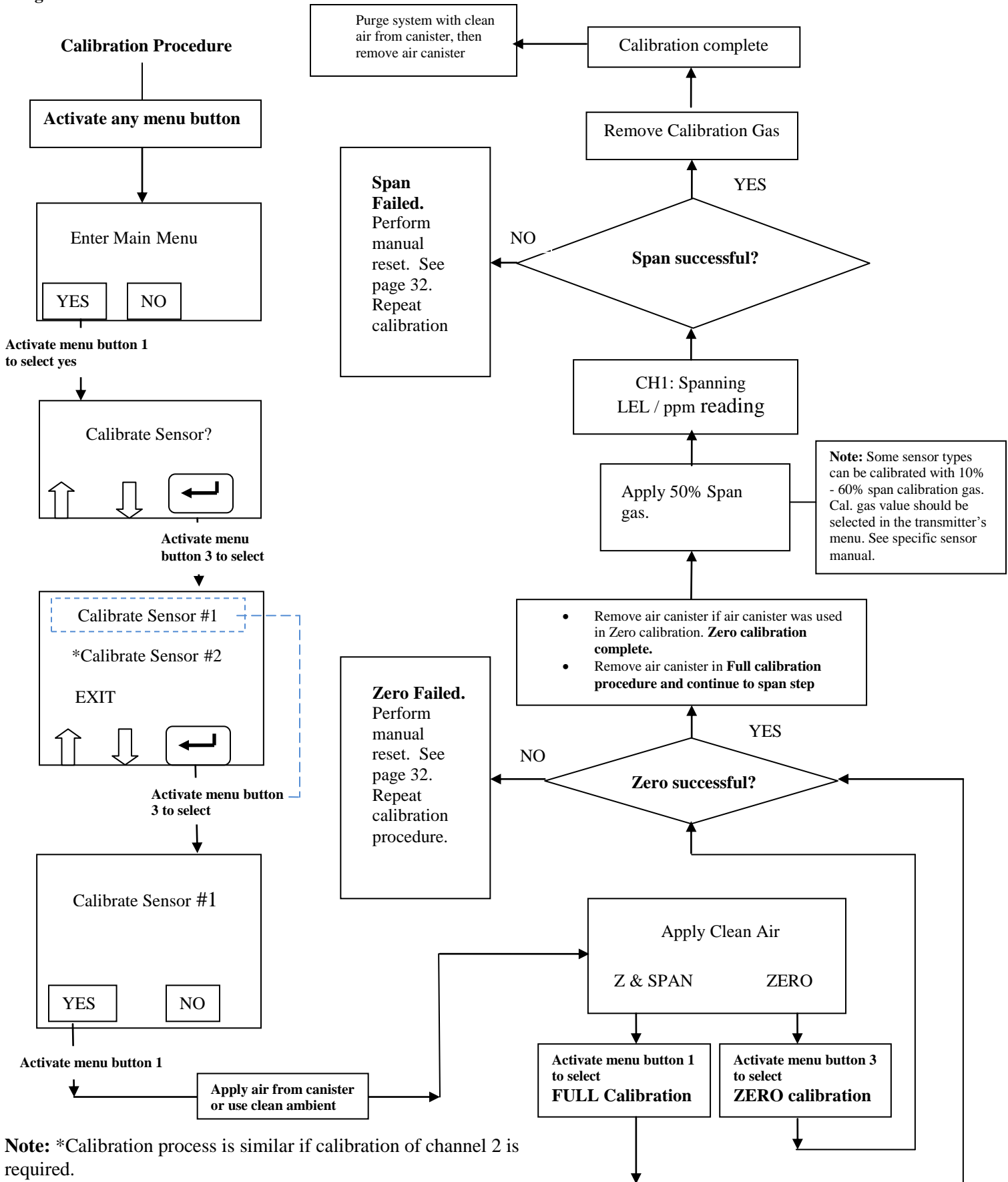

**Note:** \*Calibration process is similar if calibration of channel 2 is required.

### 4.2.3 Enable / Disable channels

This option allows the Millennium II Transmitter channels to be enabled or disabled. The default value is channel 1(CH1) enabled for single sensor models while channel 2(CH2) is permanently disabled. Both channels are enabled for two sensor models.

1. Enter the main menu by selecting/activating any key to get the “*enter main menu*” prompt, then activate **switch 1** to select “*yes*”.
2. Select the down arrow key (**switch 2**) with the magnet, and scroll to “*Enable/Disable Channel?*”
3. Activate the enter key (**switch 3**) to enter the option. The sub menu options: ‘*CH 1 Enabled*’ and ‘*CH 2 Enabled*’ will be highlighted.
4. **To disable a channel 1**, Activate the enter key (**switch 3**). “*CH1 disabled*” will now be highlighted / displayed.
5. **To disable channel 2**, highlight ‘*CH2 Enabled*’ use **switch 2**, then activate the enter key (**switch 3**) to configure to ‘*CH2 disabled*’.
6. To exit the main menu, select “*Exit*” with enter key at each menu stage (sub menu and main menu).

### 4.2.4 Viewing and setting alarm levels (points)

This option enables the channel low and high alarm levels to be viewed and set-up. Alarm levels (points) for each channel are user determined. Alarm Point 1 and Point 2 for channel 1 does not relate to Alarm Point 1 and Point 2 for channel 2.

1. Enter the main menu by selecting/activating any key to get the “*enter main menu*” prompt, then activate **switch 1** to select “*yes*”.
2. Activate the up key (**switch 1**) or the down key (**switch 2**) until “*Set Alarm Level?*” is highlighted / displayed.
3. Activate **switch 3** to enter the “*Set Alarm Level*” option. Sub menu options ‘*Set CH1 Level*’, ‘*Set CH2 Level*’ and ‘*Exit*’ will be displayed. ‘*Set CH1 Level*’ being highlighted.
4. **To view channel 1** alarm points, activate **switch 3**. ‘*CH1 Point 1*’ and ‘*CH1 Point 2*’ will be displayed.
5. **To view channel 2** alarm points use **switch 2**, at step 3, highlight ‘*Set CH2 Level*’, then activate **switch 3**. ‘*CH2 Point 1*’ and ‘*CH2 Point 2*’ will be displayed.
6. **To configure channel 1 alarm levels** (*Point 1* or *Point 2*), after step 4, use **switch 3** to select *CH 1 Point 1* (already highlighted) then proceed to step 8, or highlight *CH1 Point 2* using **switch 2**, then activate **switch 3** and proceed to step 8.
7. **To configure channel 2 alarm levels** (*Point 1* or *Point 2*), after step 5, use **switch 3** to select *CH2 Point 1* then proceed to step 8, or use **switch 2** to highlight *CH2 Point 2*, then activate **switch 3** to make a selection. Proceed to step 8.
8. Use **switch 1** to increase the existing values representing previously set alarm levels/points and **switch 2** to highlight and scroll across values.
9. After setting desired alarm points, select “*Exit*” at each menu stage (sub menu and main menu).

10. Apply test gas to confirm alarm level settings.

**Important:** Alarm Point 1 and Alarm Point 2 are values completely under the control of the user. If the user chooses, Alarm Point 1 can be assigned a value corresponding to a high alarm condition and Alarm Point 2 assigned a value corresponding to a low alarm condition.

To avoid confusion however, most users may want to assign Alarm Point 1 as the low alarm condition and Alarm point 2 as the high alarm condition.

#### 4.2.5 Setting Relay options

This option allows the Alarm relay coils to be configured as energized or de-energized and latching or non-latching.

- **FAULT RELAY:** The Fault relay is **Energized and Non-Latching. This relay is not configurable.**
- **ALARM RELAYS 1, 2 and 3:** Factory set as De-energized and Non-Latching. These relays are **configurable.**

1. Enter the main menu by activating any key to get the “*enter main menu*” prompt, then activate **switch 1** to select “yes”.
2. Activate the up key (**switch 1**) or down key (**switch 2**) until, “*Set Relay Options?*” is displayed.
3. Activate the enter key (**switch 3**) to enter the option. The sub menu options are: ‘*Fault relay*’, ‘*Alarm relay 1*’, ‘*Alarm relay 2*’, ‘*Alarm relay 3*’.
4. Activate the down key (**switch 2**) or up key (**switch 1**) to highlight configurable Alarm relays (‘*Alarm relay 1*’, ‘*Alarm relay 2*’, ‘*Alarm relay 3*’).
5. Activate the enter key (**switch 3**) to configure the desired Alarm relay.
6. ‘*Norm. Energized*’ or ‘*Norm.De-Energized*’ will be highlighted at the top of the display screen. To change the Energized or De-Energized setting, activate the enter key (**switch 3**).
7. To change the Latching or Non-Latching setting, activate the down key (**switch 2**) to highlight ‘*Latching*’ or ‘*Non- Latching*’, then activate the enter key (**switch 3**).
8. Once the desired relay settings have been made, select “*Exit*” at each menu stage (sub menu and main menu).

#### 4.2.6 Relay Assignment

This option allows the transmitter two (2) channels (with alarm levels/points) to be configured under the three (3) Alarm relays. When configuring under sub menu *Alarm relay 1*, “*RL1:CH1 (Point 1, Point 2, Disabled)*” and “*RL1:CH2 (Point 1, Point 2, Disabled)*” is displayed. Under sub menu *Alarm relay 2*, “*RL2:CH1 (Point 1, Point 2, Disabled)*” and “*RL2:CH2 (Point 1, Point 2, Disabled)*” is displayed, and under sub menu *Alarm relay 3*, “*RL3:CH1 (Point 1, Point 2, Disabled)*” and “*RL3:CH2 (Point 1, Point 2, Disabled)*” is displayed.

**Note 1:** RL1, RL2 and RL3 represents Alarm relays 1, 2 and 3. CH1 and CH2 represent channel1 and channel 2. Point 1 and Point 2 are Alarm level 1 and Alarm level 2. Alarm levels (points) are user determined and are unique to the specific channel.

**Note 2:** Prior to assigning relays, configure the alarm levels (points). See Section ‘4.2.4 Viewing and setting alarm levels (points)’, and then follow the steps and example below to configure the Alarm relays. Also see Table 3, Example and Table 4.

1. Enter the main menu by activating any key to get the “*enter main menu*” prompt, then activate **switch 1** to select “*yes*”.
2. Activate the up key (**switch 1**) or down key (**switch 2**) until “*Relay Assignment?*” is displayed.
3. Activate the enter key (**switch 3**) to enter the option. The sub menu: ‘*Alarm Relay 1*’, ‘*Alarm Relay 2*’, ‘*Alarm Relay 3*’ as well as ‘*Exit*’ will be displayed.
4. Choose the Alarm relay (*Alarm relay 1, Alarm relay 2, Alarm relay 3*) for configuration, by using the up-down arrow keys.
5. Activate the enter key (**switch 3**) to make the selection. The relay (RL) and channel (CH) with alarm level setting will be highlighted. The alarm level settings available are: Point 1, Point 2, and Disabled.
6. Under the specific relay with channel, activate the enter key (**switch 3**) to choose the appropriate setting. See Table 3 below.

Table 3: Available Millennium II Relay Options

	Relays and Assignment Options		
Channel # and Alarm points(levels)	ALARM RELAY 1 (RL1) with channel # and Alarm points (levels)	ALARM RELAY 2 (RL2) with channel # and Alarm points (levels)	ALARM RELAY 3 (RL3) with channel # and Alarm points (levels)
<b>CH1</b> POINT 1= Alarm level 1 POINT 2= Alarm level 2	<b>RL1:CH1</b> Point 1/Point 2/Disabled	<b>RL2:CH1</b> Point 1/Point 2/Disabled	<b>RL3:CH1</b> Point 1/Point 2/Disabled
<b>CH2</b> POINT 1= Alarm level 1 POINT 2= Alarm level 2	<b>RL1:CH2</b> Point 1/ Point 2/Disabled	<b>RL2:CH2</b> Point 1/ Point 2/Disabled	<b>RL3:CH2</b> Point 1/Point 2/Disabled

7. Once the appropriate settings are chosen, use the up or down arrow key (**switch 1**) or (**switch 2**) and **switch 3** to exit.

**Example:** LEL combustible sensor connected to channel 1 & H2S sensor connected to channel 2.

**Step 1-** Set Alarm Levels (points): Setup alarm levels for each channel, e.g. Channel 1 point 1 = 20% LEL, Channel 1 point 2 = 40% LEL, Channel 2 point 1 = 10 ppm, and Channel 2 point 2 = 20 ppm. Refer to Section ‘4.2.4: Viewing and setting alarm levels (points)’ when setting alarm levels.

**Step 2 -** Set Relay Options: Each alarm relay can be set up for energized or de-energized and latching or non-latching. Configure alarm relays options as desired. See ‘4.2.5 Setting Relay options’.

**Step 3 -** Relay Assignment: There are (3) alarm relays and (2) channels. Assign alarm relays to channels as desired, e.g.

- Alarm relay 1 assigned to Channel 1 Point 1 (20% LEL),
- Alarm relay 2 assigned to Channel 2 Point 1 (10 ppm) &
- Alarm relay 3 assigned to Channel 1 Point 2 (40% LEL)
- Alarm relay 3 assigned to Channel 2 Point 2 (20 ppm).

**Table 4: Typical Millennium II Relay Configurations**

Channel # and selected Alarm points (levels)	Relay Assignment Example		
	ALARM RELAY 1 (RL1)	ALARM RELAY 2 (RL2)	ALARM RELAY 3 (RL3)
<b>CH1</b> POINT 1=20% lel POINT 2=40% lel	<b>RL1:CH1</b> POINT 1=20% lel	<b>RL2:CH1</b> Disabled	<b>RL3:CH1</b> POINT 2=40% lel
<b>CH2</b> POINT 1=10 ppm POINT 2=20 ppm	<b>RL1:CH2</b> Disabled	<b>RL2:CH2</b> POINT 1=10 ppm	<b>RL3:CH2</b> POINT 2=20 ppm

**Note 1:** In above example, alarm relay 3 (RL3) will trigger whenever any alarm level 2(point 2) is reached.

**Note 2:** For the single channel relay model transmitter, all (3) alarm relays are available for channel 1.

#### 4.2.7 Relay Alarm Mode setting (for Oxygen sensors only)

**This option is available for detecting oxygen levels.** The user is allowed to set up two Alarm points/level (normal oxygen level is 20.9 %) under three available Alarm Modes. These Alarm Modes are: Above-Above, Below-Below and Below-Above. The Alarm Mode chosen by the user depends on the particular application/operation. If surrounding air is to be used for calibration, ensure that no contaminants are present. **Refer to the Oxygen Sensor Manual (MAN-0093) for detailed information.**

#### 4.2.8 Select Display Language

This option allows the display language to be selected. The default language is English. There are also options for Spanish, French, and Portuguese.

1. Enter the main menu by activating any key to get the “*enter main menu*” prompt then activate **switch 1** to select “*yes*”.
2. Activate the up key (**switch 1**) or down key (**switch 2**) until “*Select Display Language?*” is displayed.
3. Activate the enter key (**switch 3**). The default language, ‘*English*’, will be displayed.
4. Locate other languages by activating the enter key (**switch 3**).
5. Once the desired language is displayed, select “*Exit*” at each menu stage (sub menu and main menu).

#### 4.2.9 MODBUS Setup

This option enables the following MODBUS parameters to be set:

- Addressing: From 001 (**default**) to 247
- Baud Rate: 02400 bps, 04800 bps, 09600 bps (**default**), 19200 bps, and 57600 bps.
- Frame Format: EVEN Parity (**default**), ODD Parity, NO Parity.

1. Enter the main menu by activating any key to get the “*enter main menu*” prompt, then activate **switch 1** to select “*yes*”.
2. Select the up arrow key (**switch 1**) or down arrow key (**switch 2**) until “*Modbus Setup*” option is displayed.

3. Activate the enter key (**switch 3**) to display ‘*slave address*’ (default address: 001).
4. Use the up key (**switch 1**) to increase the address and the down key (**switch 2**) to decrease the value. The value range is 001-247.
5. Activate the enter key (**switch 3**) when the desired value is displayed.
6. After setting the Slave Address, exit to this sub menu option using **switch 3**.
7. Activate the down key (**switch 2**) to highlight ‘*baud rate*’, then activate the enter key (**switch 3**) to display the current baud rate.
8. Use the up key (**switch 1**) to increase the baud rate and the down key (**switch 2**) to decrease it.
9. Activate the enter key (**switch 3**) when the desired value is displayed.
10. After setting the baud rate, exit this sub menu option using **switch 3**, and then activate the down arrow key (**switch 2**) to highlight ‘*Parity Bit*’.
11. Activate **switch 3**, then activate the up key (**switch 2**), or the down key (**switch 1**) to choose a value.
12. Activate the exit key (**switch 3**) when the desired value is displayed, then select “*Exit*” at each menu stage (sub menu and main menu).

### 4.3.0 Setup Current Date

This option allows you to set the current date for event logging. The default date is set at the factory in Mountain Time (MT).

1. Enter the main menu by selecting/activating any key to get the “*enter main menu*” prompt, then activate **switch 1** to select “*yes*”.
2. Activate the up key (**switch 1**) or down key (**switch 2**) until “*Setup Current Date?*” option is displayed.
3. Activate the enter key (**switch 3**) to display the sub menu option ‘*year*’, ‘*month*’, ‘*day*’.
4. Activate the up key (**switch 1**) to change the current year/month/day settings and **switch 2** to cycle across ‘*year*’, ‘*month*’, ‘*day*’ values and ‘*OK*’.
13. After desired setting are made, navigate to “*OK?*” and activate the enter key (**switch 3**) to confirm. To exit main menu, select “*Exit*” at each menu stage (sub menu and main menu).

### 4.3.1 Setup Current Time

This option allows you to set the current time for event logging. The default time is in Mountain Time (MT)

1. Enter the main menu by activating any key to get the “*enter main menu*” prompt, then activate **switch 1** to select “*yes*”.
2. Activate the up key (**switch 1**) or down (**switch 2**) until “*Setup Current Time?*” option is displayed.

3. Activate the enter key (*switch 3*) to display the sub menu: *hour*, *minute*, *seconds*.
4. Activate the up arrow key (*switch 1*) to change the current hour/minute/second settings, then use *switch 2* to cycle across *hour*, *minute*, *seconds* values and *OK*.
5. After desired settings are made, navigate to *OK* and activate the enter key (*switch 3*) to confirm. To exit main menu, select *Exit* at each menu stage (sub menu and main menu).

### 4.3.2 View Event Log

The Millennium II Transmitter has the ability to store up to 980 events. Events can be viewed by navigating through this menu option. The most recent events are shown first.

1. Enter the main menu by activating any key to get the *“enter main menu”* prompt, then activate *switch 1* to select *“yes”*.
2. Navigate through the main menu using *switch1* or *switch 2* until *“View Event Log?”* is displayed.
3. Activate the enter key (*switch 3*) to display the sub menu. The most recent event will be displayed.
4. Select the up arrow key (*switch 1*) and the down arrow key (*switch 2*) to toggle through all past events.
6. After viewing, select *“Exit”* at each menu stage (sub menu and main menu).

The on-screen Events Format/host includes:

- **Channel Number:** **CH1**, **CH2**, or transmitter: **ML2**. Events that occurred under these formats will be logged.
- **Event Types:** There are a total of 11 events that are stored and displayed. See Table 5 for a list of the events, and how they are displayed on the Millennium II screen.
- **Date and Time:** Each event is date and time stamped.

**Table 5: Event Types**

Event Types	Display on Screen	Events Format /host
Power up or Reset	Power UP / RST	ML2
Communication Fault	Communication Err	CH1 or CH2
High Level Alarm	High Alarm	CH1 or CH2
Low Level Alarm	Low Alarm	CH1 or CH2
Calibration Completed	Cal Complete	CH1 or CH2
Calibration Zero Failed	Cal Zero fail	CH1 or CH2
Calibration Span Fail	Cal Span Fail	CH1 or CH2
Calibration Aborted	Cal Abort	CH1 or CH2
Sensor Fail	Sensor Fail	CH1 or CH2
Channel Enabled	Enabled	CH1 or CH2
Channel Disabled	Disabled	CH1 or CH2



### 4.3.3 Manual Reset

A Manual Reset is required after a calibration failure or to clear a latched Alarm relay. When a manual reset is done, the transmitter will return to normal operation.

1. Enter the main menu by activating any key to get the “*enter main menu*” prompt, then activate **switch 1** to select “yes”.
2. Activate the up key (**switch 1**) or down key (**switch 2**) until “*Manual Reset?*” option is displayed.
3. Activate the enter key (**switch 3**) to display the sub menu: ‘*Initiate Reset*’.
4. Select “yes” using **switch 1** to reset.

### 4.3.4 Self Test Relay

The Self test relay option continuously turns relays on and off to ensure that they are functioning properly. The Fault Relay is tested first, automatically followed tests on Relay 1, 2, and 3. After the relays have been tested, “*Relay Test Complete*” will be displayed. See steps to initiate relay self test below.

Proper functioning electromechanical relays have a clicking sound during this test. If the Millennium II Transmitter is equipped with Solid State relays, then an Ohm meter must be used to check the changes in resistance values between contacts.

**Warning**  When checking *self-test relay* function, ensure all external equipment is disabled to prevent unwanted alarm activation. Enable external equipment once testing is completed.

1. Enter the main menu by activating any key to get the “*enter main menu*” prompt, then activate **switch 1** to select “yes”.
2. Activate the up arrow key (**switch 1**) or down arrow key (**switch 2**) until “*Self test Relay?*” option is displayed.
3. Activate the enter key (**switch 3**) to display the sub menu: ‘*Self Test Relay. Caution, will trip alarm*’.
4. Select “yes” using **switch 1**. ‘*Ensure alarm response items are disconnected*’ will be displayed.
5. Ensure all external alarm devices are de-activated, and then select “yes” using **switch 1**.
6. After test is successfully completed, select “*Exit*”.

If a relay is malfunctioning, the transmitter should be sent to Net Safety’s Service Department for repair.

### 4.3.5 Sensor Upper Limit (Range)

This option is used to set the upper limit (range) of the gas being detected. The upper limit will vary depending on the sensor used and may not be selectable for all sensors.

1. Enter the main menu by activating any key to get the “*enter main menu*” prompt, then activate **switch 1** to select “yes”.
2. Activate the up key (**switch 1**) or down key (**switch 2**), until “*Sensor Upper Limit (Range)*” option is displayed.
3. Activate the enter key (**switch 3**) to display the sub menu: ‘*CH1: range*’, ‘*CH2: range*’.

4. Select the channel (sensor) to be configured and adjust the sensor's range using the up-down arrow keys (*switch 1*) or (*switch 2*). The specific sensor provides the upper limits/ranges.

**Note:** If no selections appear when activating the up/down arrow keys at this stage, the specific sensor only has one upper limit/range, which cannot be altered.

5. Activate the enter key (*switch 3*) when the desired upper limit/range is reached.
6. To exit, select "Exit" at each menu stage (sub menu and main menu).

### 4.3.6 Select Gas Type

"Select Gas Type" option allows the user to select a particular target gas and/or Correction ("K") Factor in the case of Catalytic Bead sensors or choose the type of LEL gas (gas curve) in the case of IR sensors. See specific sensor manual in relation to this menu option.

### 4.3.7 Calibration gas value

This option allows the user to select the calibration gas value in the transmitter main menu. Although it is recommended that 50% span gas should be used for calibration, for some sensors, the transmitter will allow tolerance/flexibility in the calibration gas available; 10% to 60% span gas allowed for some sensor types. See specific sensor manual.

1. Enter the main menu by activating any key to get the "enter main menu" prompt, then activate *switch 1* to select "yes".
2. Activate the up key (*switch 1*) or down key (*switch 2*), until "Cal. Gas value" option is displayed.
3. Activate the enter key (*switch 3*). Channel1 and channel 2 existing calibration gas values will be displayed in three numeric groups: 'hundreds', 'tens', and 'ones'. For example: **0 5 0** indicates a calibration gas value of 50% span.
4. Highlight the required channel with calibration gas value using the navigation keys (*switch1*) or (*switch 2*), then select using *switch 3*. *Switch 1* is used to increase /change a value in each numeric group, while *switch 2* is used to cycle across the numeric groups.
5. To exit, select "Exit" at each menu stage (sub menu and main menu).

### 4.3.8 Serial Number & Firmware Version

This option is used when the serial number or firmware version of the Millennium II Transmitter is required.

1. Enter the main menu by activating any key to get the "enter main menu" prompt, then activate *switch 1* to select "yes".
2. Activate the up key (*switch 1*) or down key (*switch 2*), until "Serial Number and Firmware Version" option is displayed.
3. Activate the enter key (*switch 3*). The firmware version and serial number will be displayed.
4. To exit, select "Exit" at each menu stage (sub menu and main menu).

## SECTION 5: Monitoring and outputs

### 5.1 Fault monitoring

Self-testing circuitry continuously checks for problems that could prevent proper response. When power is applied to the Millennium II Transmitter, a micro controller automatically tests the system to ensure that it is functioning properly. During normal operation, it continuously monitors the signal from the internal sensor source. In addition, a “watchdog” timer is maintained to ensure the program is running correctly. When a system fault is detected, the Status LED will have a Red fast flash and the fault signal will output a 2.5 mA signal. The transmitter’s event log may be viewed in order to distinguish the fault condition. Refer to the Event Log menu option.

**Warning**  The fault detection circuitry does not monitor the operation of external response equipment or external wiring to the transmitter. It is important that external equipment and wiring be checked periodically to ensure they are operational.

### 5.2 Relays

Standard electro-mechanical relays have Form C SPDT contacts rated 5 Amps at 30 VDC/ 250 VAC. There are four physical relays; one Fault and three Alarm relays. These relays have Normally Open and Normally Closed contacts at the output terminals. Solid State relays are Form A contacts rated 2.5 Amps at 60 VAC/DC. These relays also have one Fault and three Alarm relays.

Alarm relays are configurable and can be assigned values; the user is allowed to assign values corresponding to desired alarm conditions, under Relay 1, Relay 2 or Relay 3 for each channel. Relays can be selected to be ‘Energized’ or ‘De-energized’ and ‘Latching’ or ‘Non-latching’. See “*relay assignment*” option for reference.

**NOTE:** The fault relay output is not commonly used to imitate an automatic shutdown. The fault output indicates a potential problem with the transmitter not an alarm condition.

### 5.3 Analog 4-20mA

A 4-20 mA current output is used to transmit the transmitter and sensor status and fault codes to other devices. This output can be wired for isolated or non-isolated operation. A 4.0 mA output indicates normal operation; the transmitter’s output current range is 4.0 - 20.0 mA. For a full list of output current values and what they indicate, see “Sensor Status Registers, Status LEDs, Current Loop, and Display Messages”

## Sensor Status Registers, Transmitter Status LED, Current output and Meaning

Table 6 below, shows the sensor status registers, and the transmitter's current output, along with corresponding status LED and meaning.

**Note:** To differentiate between conditions resulting in 2.5 mA, view the Event Log. See Event Log menu option.

**Table 6: Current output and meaning**

Reg. Value	Current Output (mA)	Status LED		Meaning
		Red	Green	
0	4 – 20	Slow Flash (Gas found)	Flash (No Gas)	Normal Sensor operation – regularly calculates gas concentration.
1	3.0		Solid	Sensor is zeroing itself ( Cal Mode)
2	3.3	Very Fast Flash		Sensor is waiting until it detects application of cal gas.
3	3.3	Very Fast Flash		Sensor waits until gas level stabilizes, then begins spanning.
4	3.6		Solid	Spanning is complete, user asked to remove gas.
5	3.6		Solid	Displayed for 4 seconds once gas decreases to 3% FS after user asked to remove cal gas.
6	2.5	Very Fast Flash		Sensor is not calibrated, requires user to calibrate.
7	3.0	Slow Flash		Sensor is waiting for 90 seconds to allow the signal to stabilize ( Start Delay)
9	3.0/3.3	Solid	Solid	Signal was too unstable to acquire accurate zero after 90 seconds
10	3.0/3.3	Solid	Solid	Displayed for 4 seconds is the cal gas was removed prematurely <b>OR</b> is a 90 second time limit has elapsed and the signal was too unstable to acquire accurate data
11	4 – 20	Fast Flash		See Event Log in transmitter main menu.
12	4 – 20	Fast Flash		See Event Log in transmitter main menu.
13	2.5	Fast Flash		<b><u>FAULT DETECTED:</u></b> Input voltage <8V.
14	2.5	Fast Flash		<b><u>FAULT DETECTED:</u></b> Input voltage >33V.

**Table 6: Current output and meaning (cont'd)**

Reg. Value	Current Output (mA)	Status LED		Meaning
		Red	Green	
15	2.5	Fast Flash		Sensor Element Failure
16	20.0	Solid		The concentration value is greater than the allowed range; the sensor is displaying its maximum concentration value.
17	2.5	Fast Flash		<b>FAULT DETECTED:</b> Sensor baseline has drifted into a “Negative Gas Concentration” region (Zero Drift) and requires re-calibration.
18	4-20	Fast Flash		Sensor is nearing end of life. Replace at next calibration.
20	2.5	Fast Flash		<b>FAULT DETECTED:</b> A critical memory fault has occurred.
21	2.5	Fast Flash		<b>FAULT DETECTED:</b> A fault has occurred in the sensor’s onboard power supply.

**Note:** A slow flash is defined as the Status LED being ‘ON’ for 50 milli-seconds and ‘OFF’ for 1 second, while a fast flash is the LED being ‘ON’ for 250 milli-seconds and ‘OFF’ for 250 milli-seconds and a very fast flash is the LED ‘ON’ for 50 milli-seconds and ‘OFF’ for 50 milli-seconds.

### 5.4 RS-485 Modbus RTU

RS-485 Modbus RTU protocol is used. Tables 7 and 8 on the following pages give the detailed MODBUS registers and the bit values for the transmitter register.

The Millennium II Transmitter utilizes 2-wire Modbus RS-485 multi serial mode. This Modbus solution implements a 2-wire electrical interface in accordance with the EIA/TIA-485 standards. For this MODBUS configuration, it is important that a third wire be used for connecting all the ‘Common’ (COM) in the chain. Also a 120 Ohm line termination is required for the last device in the line. See Figure 19. The Instrument Engineer is responsible for calculating line length and adhering to MODBUS protocols.

**Figure 19: Two (2)-Wire Modbus configuration**

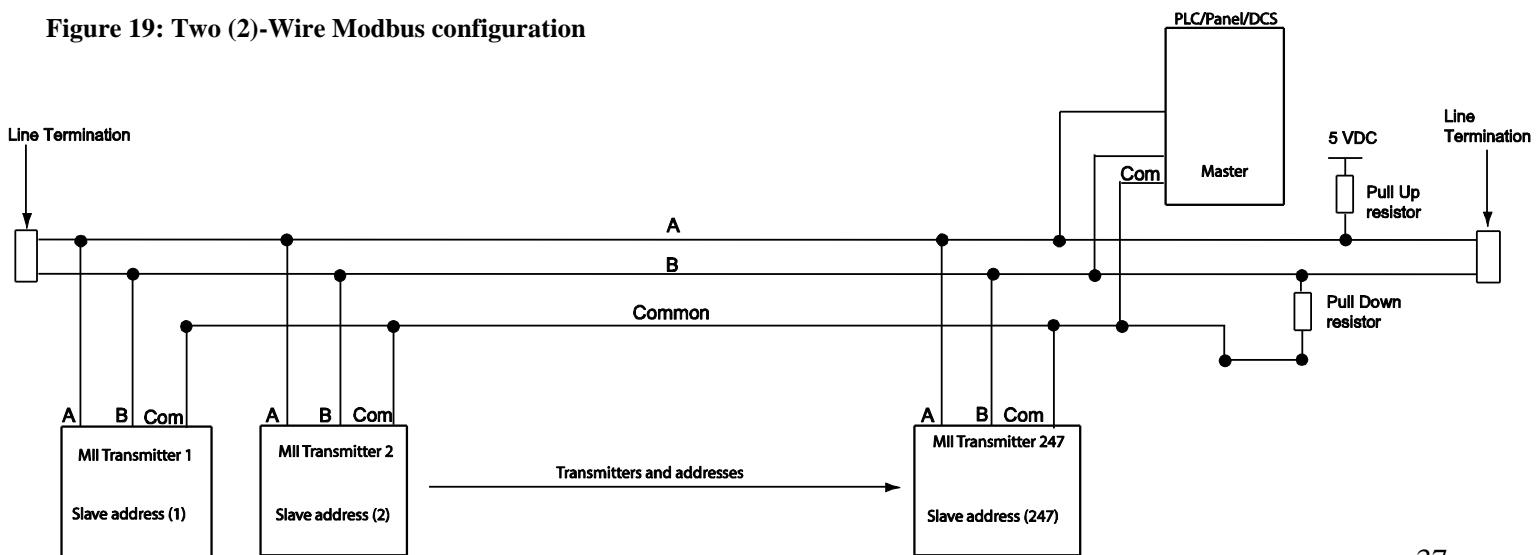

**Table 7: Modbus Registers**

Reg#	Meaning	Readable	Writeable
40001	Concentration value as calculated by sensor (RTUsensor_out), Channel 1	X	
40002	Sensor status (RTUsensor_stat), Channel 1	X	
40003	Temperature of sensor element housing in Kelvin (RTU temperature), Channel 1	X	
40004	RFU, Channel 1, always read as 0x0000	X	
40005	RFU, Channel 1, always read as 0x0000	X	
40006	Concentration value as calculated by sensor (RTUsensor_out), Channel 2	X	
40007	Sensor status (RTUsensor_stat), Channel 2	X	
40008	Temperature of sensor element housing in Kelvin (RTU temperature), Channel 2	X	
40009	RFU, Channel 2, always read as 0x0000	X	
40010	RFU, Channel 2, always read as 0x0000	X	
40011	Concentration value as calculated by sensor (RTUsensor_out), Channel 3	X	
40012	Sensor status (RTUsensor_stat), Channel 3	X	
40013	Temperature of sensor element housing in Kelvin (RTU temperature), Channel 3	X	
40014	RFU, Channel 3, always read as 0x0000		
40015	RFU, Channel 3, always read as 0x0000		
40016	Concentration value as calculated by sensor (RTUsensor_out), Channel 4	X	
40017	Sensor status (RTUsensor_stat), Channel 4	X	
40018	Temperature of sensor element housing in Kelvin (RTU temperature), Channel 4	X	
40019	RFU, Channel 4, always read as 0x0000	X	
40020	RFU, Channel 4, always read as 0x0000	X	
**40021	Transmitter Status	X	
40022 To 40090	RFU		
40091	Initialize Quick calibration, channel 1 to 4	X	X
40092	Initialize Normal Calibration, channel 1 to 4	X	X
NOTE: Alarm points can be set up through MPDBUS registers 40093 to 40096			
40093	Channel 1 high alarm limit	X	X
40094	Channel 1 low alarm limit	X	X
40095	Channel 2 high alarm limit	X	X
40096	Channel 2 low alarm limit	X	X
40097	RFU, Channel 3 high alarm limit	X	X
40098	RFU, Channel 3 low alarm limit	X	X
40099	RFU, Channel 4 high alarm limit	X	X
40100	RFU, Channel 4 low alarm limit	X	X
40101	Reset latch relays		X

*\*RFU – Reserved for future use*

*\*\* The transmitter Status register (Register 40021) is a bit flag register. Table 8 on next page, shows the detailed meaning of each bit in the register.*

**Table 8: Transmitter Status Register value and meaning**

Bit	Meaning
0x0000	Normal Sensor operation – no fault or alarm has happened
0x0001	Channel 1 sensor fault status tripped. Communication Fault, Calibration Fault, etc
0x0002	Channel 1 Low Alarm tripped
0x0004	Channel 1 High Alarm tripped
0x0008	Channel 2 sensor fault status tripped. Communication Fault, Calibration Fault, etc
0x0010	Channel 2 Low Alarm tripped
0x0020	Channel 2 High Alarm tripped
0x0040	Channel 1 needs Calibration
0x0080	Channel 2 needs Calibration

### 5.5 HART Communication

The HART protocol is a powerful communication technology enabling users to exploit the full functionality of the Millennium II Transmitter. **The HART communication option is only available with the single channel version of the Millennium II Transmitter.** The Millennium II Transmitter is a generic device that will work with other universal communication devices.

The HART Communicator may be connected to the single channel Analog/HART model Millennium II Transmitter via the HART Port connector (HPT-001) which provides the necessary interface for communication. The HART Port connector is fitted to one of the 3/4" NPT conduit entries and its communication wires fitted to the HART Pins located at J5 near the ribbon cable on the underside of the display/CPU assembly. The HART Communicator probe wires (leads) are then connected to HART Port connector contact points. HART Communication may also be done remotely using a designated Net Safety Multipurpose Junction box (JB-MPH-A/S). See the HART Port connector manual (MAN-0083) for more details. When remote HART Communication is being done, ensure the HART jumper is connected across pins at J5 near ribbon cable on display/CPU assembly. By default the jumper is connected across pins. The HART Communicator can be connected directly in the 4-20mA signal wiring across a 250 - 600 Ohm resistor. Do not install resistor within transmitter. See Figure 20.

**Figure 20: Analog/HART wiring**

**Analog/HART single channel model Millennium II**

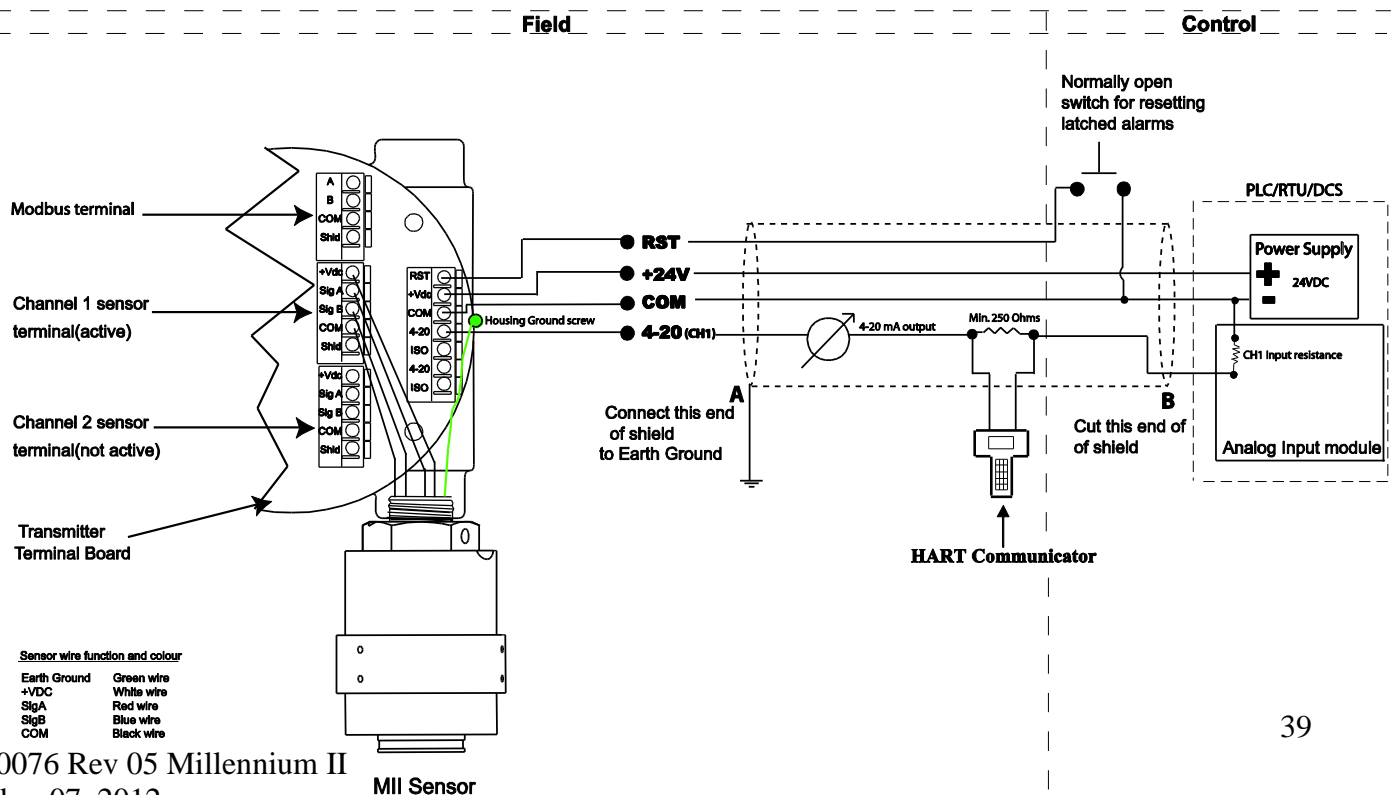

## **SECTION 6: Maintaining**

### ***6.1 Periodic response check***

Net Safety Monitoring recommends that a bump test be performed every 90 days to ensure continued functionality and accuracy of the detection system. Full calibration is recommended when the sensor fails to meet acceptable accuracy standards. This involves the application of calibration gas to the sensor, then the observation of the response LEDs, analog output, and external monitoring equipment. Be sure to prevent unwanted response of external monitoring devices and equipment during this procedure. If the Millennium II's response to calibration gas is within the specified accuracy then it is not necessary to perform a calibration.

Example:

When 50% of full scale is applied, the response is expected to be between 11.5 mA (47% of full scale) and 12.5 mA (53% of full scale). An additional consideration is the accuracy tolerance of the calibration gas which may be + or - a few percent. If the calibration gas is + or - 10% of full scale then the reading may be from 10.7 mA (42% of full scale) to 13.3 mA (58% of full scale).

### ***6.2 Troubleshooting***

Response to the input should be checked and, if necessary, calibration should be performed whenever the accuracy of this check is not satisfactory. The system should also be checked when sensor or transmitter is added or removed. If problems should develop, first check for faulty wiring, confirm proper voltage to transmitter and attempt a calibration. If problems persist, please contact Net Safety's Service Department first by phone to try and resolve any issues. If issues cannot be resolved, please follow the procedure on 'how to return equipment'.



### 6.3 Storage

The transmitter and its electronic components/parts should be stored in locations free from dust and moisture. The storage temperature should be well within the limits of the certified temperatures. See Appendix C for certified temperatures.

### 6.4 Spare Parts /Accessories

**Table 9: Spare Parts Numbering**

Net Safety Part Number	Description
CCS-1	Calibration Cup/Splash Guard
DSC-1	Dust Filter Assembly
IPF-001	IP66/67 Hydrophobic Filter
JB-MPD-A or JB-MPD-S	Separation Kit
TX-M21-A	Single channel transmitter w/analog output
TX-M21-AR	Single channel transmitter w/analog & mech. relay outputs
TX-M21-ARS	Single channel transmitter w/analog & solid state relay output
TX-M21-AD	Single channel transmitter w/analog & digital Modbus outputs
TX-M21-ARD	Single channel transmitter w/analog , mech. relay & digital Modbus output
TX-M21-AH	Single channel transmitter w/ analog / Hart communication output
TX-M21-AHR	Single channel transmitter w/analog /Hart communication & relay output
TX-M22-A	Dual channel transmitter w/analog output
TX-M22-AR	Dual channel transmitter w/analog and mech. relay output
TX-M22-ARS	Dual channel transmitter w/analog & solid state relay output
TX-M22-AD	Dual channel transmitter w/analog & digital Modbus output
TX-M22-ARD	Dual channel transmitter w/analog, relay & digital Modbus output

## ***6.5 How to Return Equipment***

A Material Return Authorization number is required in order to return equipment. Please contact Net Safety Monitoring at **(403) 219-0688**, before returning equipment or consult our Service Department to possibly avoid returning equipment.

If you are required to return equipment, include the following information:

1. A Material Return Authorization number (provided over the phone to you by Net Safety).
2. A detailed description of the problem. The more specific you are regarding the problem, the quicker our Service Department can determine and correct the problem.
3. A company name, contact name and telephone number.
4. A purchase order, from your company, authorizing repairs or request for quote.
5. Ship all equipment, prepaid to:  
**Net Safety Monitoring Inc.,  
2721 Hopewell Place NE,  
Calgary, Alberta, Canada, T1Y 7J7**
6. Mark all packages: **RETURN for REPAIR.**
7. Waybills, for shipment outside Canada, must state:  
**Equipment being returned for repair  
All charges to be billed to the sender**

Ensure a duplicate copy of the packing slip is enclosed inside the box indicating item 1 – 4 along with the courier and account number for returning the goods.

Pack items to protect them from damage and use anti-static bags or Aluminum-backed cardboard as protection from electro-static discharge.

**ALL equipment must be shipped prepaid. Collect shipments will not be accepted.**

# Appendix

## Appendix A: ELECTROSTATIC SENSITIVE DEVICE (ESD)

**Definition:** Electrostatic discharge (ESD) is the transfer, between bodies, of an electrostatic charge caused by direct contact or induced by an electrostatic field.

The most common cause of ESD is physical contact. Touching an object can cause a discharge of electrostatic energy—ESD! If the charge is sufficient and occurs near electronic components, it can damage or destroy those components.

In some cases, damage is instantaneous and an immediate malfunction occurs. However, symptoms are not always immediate—performance may be marginal or seemingly normal for an indefinite period of time, followed by a sudden failure.

To eliminate potential ESD damage, review the following guidelines:

- Handle boards by metal shields—taking care not to touch electronic components
- Wear grounded wrist or foot straps, or ESD shoes or heel grounders to dissipate unwanted static energy
- Prior to handling boards, dispel any charge in your body or equipment
- Ensure components are transported and stored in static safe packaging
- When returning boards, carefully package in the original carton and static protective wrapping
- Ensure ALL personnel are educated and trained in ESD Control Procedures

In general, exercise accepted and proven precautions normally observed when handling electrostatic sensitive devices. A warning label is placed on the packaging, identifying product using electrostatic sensitive semiconductor devices.





## Appendix B: Resistance Table<sup>1</sup>

Distance (Feet)	AWG #20 0.5mm <sup>2</sup>	AWG #18 0.8mm <sup>2</sup>	AWG #16 1.0mm <sup>2</sup>	AWG #14 2.0mm <sup>2</sup>
100	1.02	0.64	0.40	0.25
200	2.03	1.28	0.80	0.51
300	3.05	1.92	1.20	0.76
400	4.06	2.55	1.61	1.01
500	5.08	3.20	2.01	1.26
600	6.09	3.83	2.41	1.52
700	7.11	4.47	2.81	1.77
800	8.12	5.11	3.21	2.02
900	9.14	5.75	3.61	2.27
1000	10.20	6.39	4.02	2.53
1250	12.70	7.99	5.03	3.16
1500	15.20	9.58	6.02	3.79
1750	17.80	11.20	7.03	4.42
2000	20.30	12.80	8.03	5.05
2250	22.80	14.40	9.03	5.68
2500	25.40	16.00	10.00	6.31
3000	30.50	19.20	12.00	7.58
3500	35.50	22.40	14.10	8.84
4000	40.60	25.50	16.10	10.00
4500	45.70	28.70	18.10	11.40
5000	50.10	32.00	20.10	12.60
5500	55.80	35.10	22.10	13.91
6000	61.00	38.30	24.10	15.20
6500	66.00	41.50	26.10	16.40
7000	71.10	44.70	28.10	17.70
7500	76.10	47.90	30.10	19.00
8000	81.20	51.10	33.10	20.20
9000	91.40	57.50	36.10	22.70
10000	102.00	63.90	40.20	25.30

<sup>1</sup> Resistance shown is one way. This figure should be doubled when determining closed loop resistance.

## Appendix C: MILLENNIUM II Transmitter Specifications

Transmitter model	Analog-Relay	Analog	Analog/HART	Digital
<b>Electrical</b>				
Power Consumption (with sensor attached)	IR: <150 mA @ 24 VDC Solid State( H2S or Ammonia): 100mA @24VDC			
Voltage Range	10.5 – 32 VDC	10.5 – 32 VDC	18 – 32 VDC	10.5 – 32 VDC
RFI, EMC, Immunity	RFI: 150 to 170 MHz and 450 to 470 MHz, 5W FM radio at 1 meter away; EMC: IEC 61000-1-4 and IEC 61000-4-3 Severity Level 2			
<b>Display</b>				
Display	OLED and Status LED's (Separate status for Normal, Fault & Alarm)			
<b>Environmental</b>				
Temperature	Certified : -55°C to +85°C (Note: See sensor manuals for sensor certified temperatures).			
RH	0 – 99% RH non-condensing			
<b>Enclosure</b>				
Metallurgy	Copper Free Aluminum (AL6061) or Stainless Steel (SS316)			
IP/NEMA	IP67 / NEMA 4X			
<b>Mounting</b>				
Mounting	Surface Mount, Pipe Mount & other mounting options available.			
<b>Outputs</b>				
Outputs	(4) Mechanical Relays 5A Form C contacts 30VDC/250Vac OR (4) Solid State Relays 2.5A Form A contacts 60VDC/VAC	4 – 20 mA - into a maximum loop impedance of 800 Ohms @ 32VDC or 150 Ohms @ 10.5VDC. Isolated or non-isolated loop supply	4 – 20 mA with HART communication protocol	RS 485 Modbus RTU

Approvals	
Electronics Module	<div style="text-align: center;">  </div> <p>Class I, Div 2 Grps ABCD; Class I, Zone 2 AEx/Ex nA nC IIC, T5.            FM07ATEX0014X: <b>CE</b> 0575 <b>Ex</b> II 3G. Ex nAnC IIC, T5, Certified -55°C to +85°C.            Certified to FM 6320, CSA-C22.2 No. 152, ANSI/ISA-92.0.01, ANSI/ISA-92.03.01 FM6340, EN61779-1, EN61779-4.</p> <p style="text-align: center;"><b>TX-M2a-b, Millennium II Transmitter Electronic Module Only (w/o enclosure) Specific Conditions of Use:</b></p> <ol style="list-style-type: none"> <li>1. If the Millennium II Transmitter is installed as Category 3 equipment, then it shall be installed in an Enclosure which maintains an ingress protection rating of IP54 and meets the enclosure requirements of EN 50014 or EN 60079-0.</li> <li>2. In order to maintain the performance of the system, the sensor to which the instrument is connected to shall also comply with requirements of EN 61779-1 and EN 61779-4</li> </ol>
316SS Enclosure	<div style="text-align: center;">  </div> <p>Class I, Div I Grps BCD; Class I, Zone 1 AEx/Ex d IIB+H2, T5, IP67, Type 4X,            Certified -55°C to +85°C.            Certified to FM 6320, CSA-C22.2 No. 152, ANSI/ISA-92.0.01, ANSI/ISA-92.03.01 FM6340, EN61779-1, EN61779-4.</p> <p>FM07ATEX0013X: <b>CE</b> 0575 <b>Ex</b> II 2G, Ex d IIB+H2, T5, IP67, Certified -55°C to +85°C.</p> <p>IECEX</p> <p>Ex d IIB+H2 T5 Gb Ta = -55°C to +85°C            FMG12.0006X.            IEC 60079-0: 2007-10/IEC 60079-1:2007-04</p> <p>Condition of use: Consult the manufacturer if dimensional information on the flameproof joints is necessary.</p>
Aluminum Enclosure	<div style="text-align: center;">  </div> <p>Class I, Div I Grps BCD; Class I, Zone 1 AEx/Ex d IIB+H2, T5, IP67, Type 4X,            Certified -55°C to +85°C.            Certified to FM 6320, CSA-C22.2 No. 152, ANSI/ISA-92.0.01, ANSI/ISA-92.03.01 FM6340, EN61779-1, EN61779-4.</p> <p>DNV-2005-OSL-ATEX-0324: <b>CE</b> 0575 <b>Ex</b> II 2G, Ex d IIB+H2, T5, IP66, Certified -40°C to +85°C.</p> <p>IECEX</p> <p>Ex d IIB+H2 T6 Gb -55°C to +85°C            DNV 12.0014            IEC 60079-0: 2007-10/IEC 60079-1:2007-04</p>
Weight (without sensor)	Aluminum(AL6061) enclosure: 2.4 kg (5.3 lbs), Stainless Steel(SS316) enclosure: 2.6 kg (5.5 lbs)

Net Safety Monitoring Inc.

2721 Hopewell Place NE, Calgary, AB Canada T1Y 7J7

1-866-FIREGAS (347-3427) | ph. (403) 219-0688 | fx. (403) 219-0694

<http://www.net-safety.com> | Email: nsmsales@net-safety.com

PRODUCT SERVICES CONTACT INFORMATION

Telephone [ 8am - 5pm MDT ]: (403) 769-6074 | (403) 717-8219

Fax: (403) 219-0694 Email: [productservices@net-safety.com](mailto:productservices@net-safety.com)

[http://www.net-safety.com/service/product\\_services.html](http://www.net-safety.com/service/product_services.html)



December 07, 2012

Net Safety Monitoring Inc