

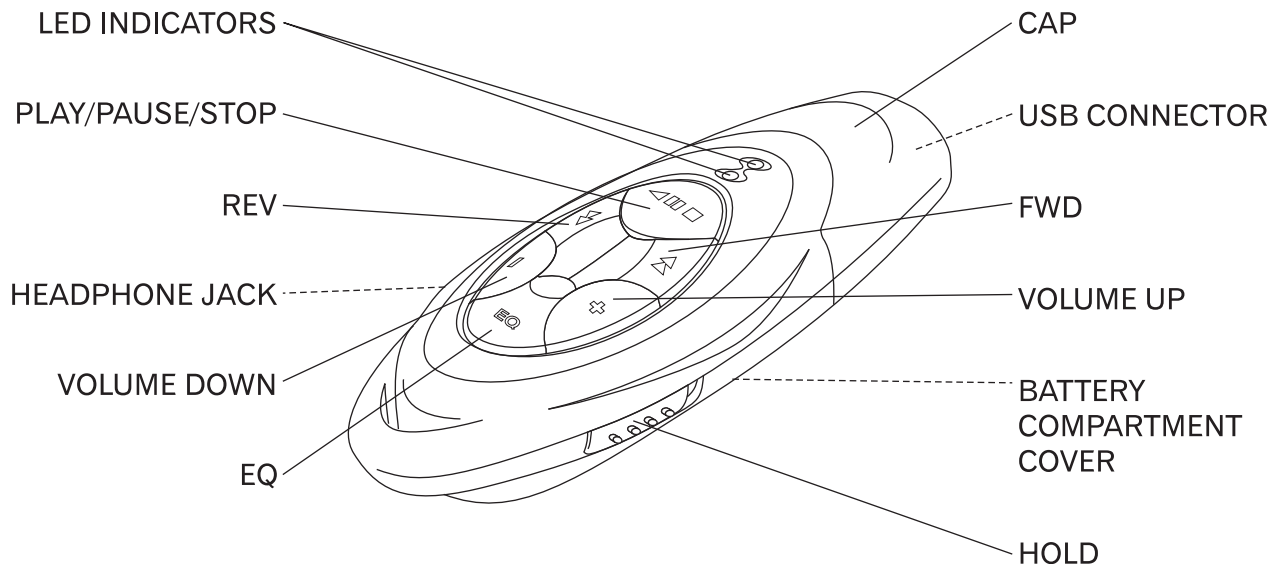

MP100

Controls



Copyright/Trademarks

© 2004 Emerson Radio Corp. All rights reserved.

Emerson Radio Corp. shall not be liable for any errors contained herein or for any damages arising out of or related to this document or the information contained herein, even if Emerson Radio Corp. has been advised of the possibility of such damages. This document is intended for informational and instructional purposes only. Emerson Radio Corp. reserves the right to make changes in the specifications and other information contained in this document without prior notification. Emerson Radio Corp. disclaims any obligation to update the information contained herein.

Microsoft, Windows Media and the Windows logo are trademarks or registered trademarks of Microsoft Corporation in the United States and/or other countries. Mac and the Mac logo are trademarks of Apple Computer, Inc. registered in the United States and/or other countries. Pentium is a registered trademark of Intel in the United States and/or other countries.

All other product names may be trademarks of the companies with which they are associated.

Emerson Radio Corp.
Parsippany, New Jersey 07054

Emerson Radio Corp. World Wide Web address:
<http://www.emersonradio.com>

Emerson Radio Corp. email address for customer inquiries: internet@emersonradio.com

Part No. 16-2953
404-01

Printed in China

Warning

To reduce the risk of shock hazard, do not expose this product to rain or any type of moisture, as well as do not disassemble the player. There are no user-serviceable parts inside.

Caution: Any changes or modifications not expressly approved by the party responsible for compliance could void the user's authority to operate this device.

Risk of explosion, damage or battery leakage is possible if battery is replaced or inserted incorrectly, as well as an incorrect type. Never attempt to charge a non-rechargeable alkaline battery. Please dispose of used batteries according to local laws.

Note: This equipment has been tested and found to comply with the limits for a Class B digital device, pursuant to Part 15 of the FCC Rules. These limits are designed to provide reasonable protection against harmful interference in a residential installation. This equipment generates, uses, and can radiate radio frequency energy and, if not installed and used in accordance with the instructions, may cause harmful interference to radio communications. However, there is no guarantee that interference will not occur in a particular installation. If this equipment does cause harmful interference to radio or television reception, which can be determined by turning the equipment off and on, the user is encouraged to try to correct the interference by one or more of the following measures:

- Reorient or relocate the receiving antenna.
- Increase the separation between the equipment and receiver.
- Connect the equipment into an outlet on a circuit different from that to which the receiver is connected.
- Consult the dealer or an experienced radio/TV technician for help.

Modifications not authorized by the manufacturer may void user's authority to operate this device.

Troubleshooting

Player is not recognized on my Windows® 98/98SE computer: Download and install the MP100 driver from the support section of www.emersonradio.com. Connect the player to your computer and follow your operating system's instructions to finish installing the driver.

After transferring files to the player, music did not play or data was not present: Make sure music is in the MP3 or WMA format. Do not disconnect the player until the red LED stops blinking.

Buttons do not work/player does not power up: Make sure the HOLD switch is in the off position. Make sure the battery is in the correct position. Replace the battery with a new one if necessary.

No sound is heard through the headphones: Check the headphone connection and adjust the volume level.

System Requirements

- Windows® 98, 98SE, ME, 2000 and XP (*Driver is required for Windows 98 / 98SE) / Mac OS 10 or higher / Linux 2.4 or higher
- IBM PC / Mac / Linux compatible machine with USB Port
- Pentium MMX® 233MHz or higher
- 64 MB minimum RAM
- 10 MB free space minimum on hard drive

1 Unpack box contents

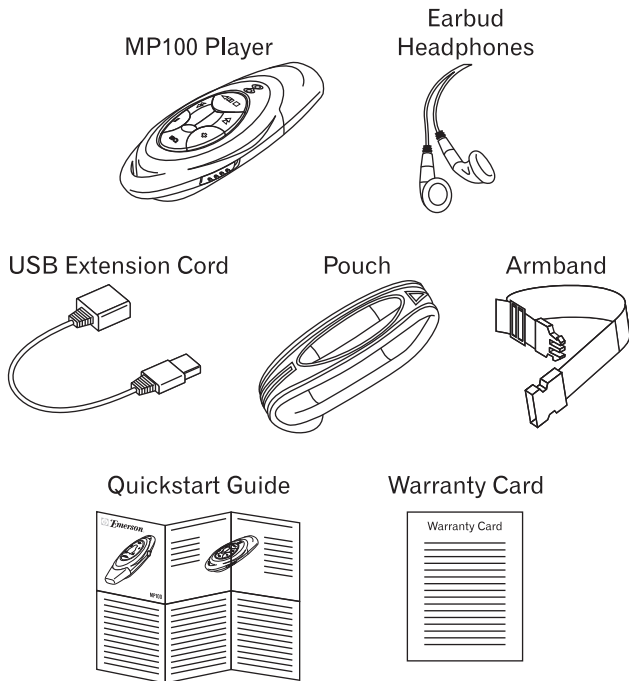

4 Transferring music and data files

1. Confirm player is connected to computer.
2. On your Desktop, double-click the "My Computer" icon.
3. Drag and drop files onto the MP100 drive ("Removable Disk"). The red LED indicator will blink when data is transferring to player. Do not disconnect until indicator is solid.

NOTE: The player stores all types of formatted files. However, it will only play MP3 and WMA formatted files.

NOTE: If you are using Windows®98 / 98SE, you must first download a driver from www.emersonradio.com. For more info, see the "Troubleshooting" section of this quickstart guide.

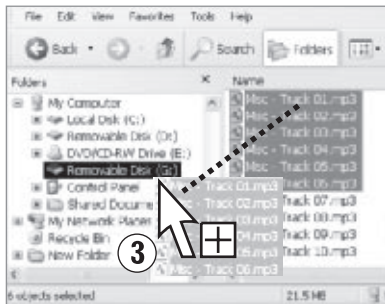

2 Insert the battery (not included)

1. Slide open the battery compartment cover.
2. Install one "AAA" battery, ensuring the "+" and "-" symbols on the battery match the symbols on the player.
3. Replace the battery compartment cover.

NOTE: The green LED indicator will be solid when the battery has full to 80% power remaining. It will blink fast at 80% power, then slower as the battery is drained.

NOTE: No battery is needed if the player is being used strictly as a USB storage device.

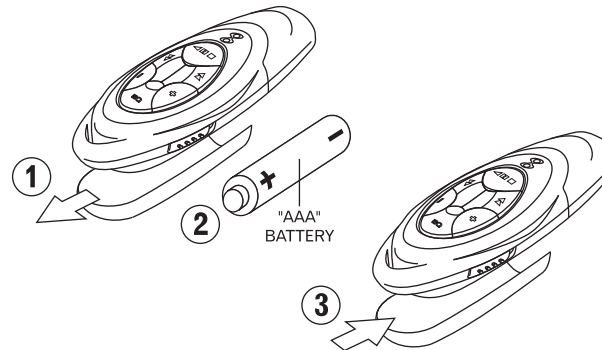

5 Use your MP100 as a MP3 player

1. Unplug player from the USB cord or computer. Make sure you have at least one MP3 or WMA file already stored on the player.
2. Slide the HOLD button to the off position (A) and power up your MP100 (B).
3. Connect the earbuds to the headphone jack.
4. Adjust volume to desired level.

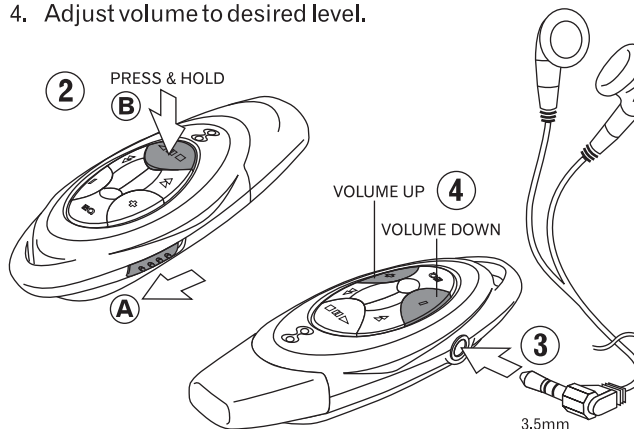

3 Connect player to your computer

1. Remove cap.
2. Place USB connector of player into female side of the USB extension cord (A). Plug the other end of the extension cord (B) into an open USB port in computer. The red LED indicator will light up when connected.

NOTE: Player can be connected directly to computer if space permits.

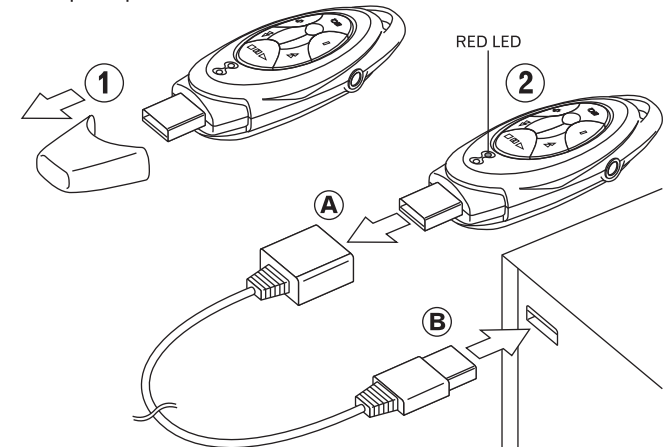

6 How to operate your player

Power on the unit: Press the PLAY/PAUSE/STOP button. The green LED indicator will light up.

To pause track: Press the PLAY/PAUSE/STOP button.

To resume track: Press the PLAY/PAUSE/STOP button when track is paused.

To select a different track: Press the FWD or REV buttons.

To adjust volume: Press the "+" or "-" buttons.

To select EQ setting: Press the EQ button repeatedly to cycle through the five preset equalizer settings.

To stop track: Press and hold the PLAY/PAUSE/STOP button for approximately 2 seconds when track is playing.

Power off the unit: Press and hold the PLAY/PAUSE/STOP button for approximately 2 seconds when tracks are stopped.

To lock the buttons from accidentally being pressed: Slide the HOLD switch to the on position.