

MR95 Series Industrial Pressure Regulators

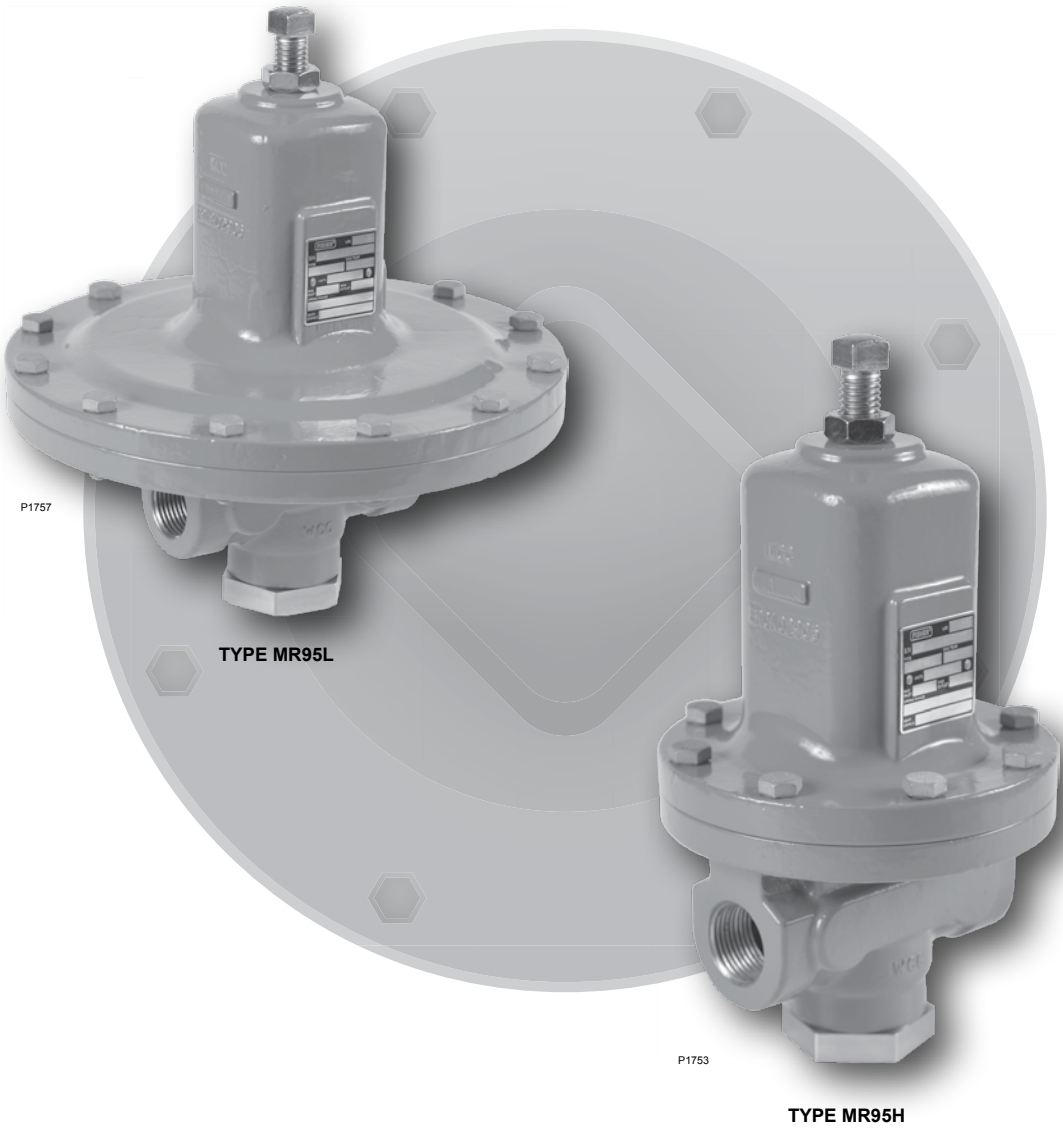

PRESSURE REDUCING REGULATORS

Figure 1. Typical MR95 Series Industrial Pressure Regulators



www.fisherregulators.com



Bulletin 71.1:MR95

Specifications

This section lists the specifications for the MR95 Series regulators. Factory specification such as type, maximum inlet pressure, maximum temperature, maximum outlet pressure, spring range, orifice size and seat material are stamped on the nameplate fastened on the regulator at the factory.

Available Constructions

Type MR95L: Low-pressure regulator for 2 to 30 psig / 0.14 to 2.1 bar outlet pressures

Type MR95H: High-pressure regulator for 5 to 150 psig / 0.34 to 10.3 bar outlet pressures

Type MR95HP: High-pressure regulator for 15 to 400 psig / 1.0 to 27.6 bar outlet pressures (soft-seated)

Type MR95HT: High-pressure/high-temperature regulator for 15 to 300 psig / 1.0 to 20.7 bar outlet pressures (metal seat) and up to 650°F / 343°C

Type MR95LD: Low-pressure differential regulator for 2 to 30 psi / 0.14 to 2.1 bar differential pressures with handwheel and packing box

Type MR95HD: High-pressure differential regulator for 5 to 150 psi / 0.34 to 10.3 bar differential pressures with handwheel and packing box

Body and Orifice Sizes

1/4 NPT body:

0.284 in. / 7.22 mm orifice

1/2 in. / DN 15 body:

0.416 in. / 10.56 mm orifice

3/4 and 1 in. / DN 20 and 25 bodies:

0.631 in. / 16.02 mm orifice

1-1/2 and 2 in. / DN 40 and 50 bodies

(not available for Types MR95L and MR95LD):

1.142 in. / 29 mm orifice

End Connection Styles

NPT, SWE and Welded and Integral CL150 RF, CL300 RF, CL600 RF and PN 16/25/40 RF; all sizes are fabricated with slip-on flanges (for welded end connections) and are 14 in. face-to-face (EN flanged-356 mm face-to-face)

See Tables 1 and 2

Maximum Cold Working Pressures of Body Size and Material⁽¹⁾

See Table 4

Outlet or Differential Pressure Ranges⁽¹⁾

See Table 3

Maximum Temperature Ranges of Diaphragm and Seat Materials⁽¹⁾⁽²⁾

MATERIAL	TEMPERATURE RANGE
Nitrile (NBR)	-40 to 180°F / -40 to 82°C
Neoprene (CR)	-40 to 180°F / -40 to 82°C
Fluorocarbon (FKM) ⁽³⁾	0 to 300°F / -18 to 149°C
Ethylenepropylene (EPDM)	20 to 275°F / -7 to 135°C
Perfluoroelastomer (FFKM)	0 to 425°F / -18 to 218°C
Polytetrafluoroethylene (PTFE)	-40 to 400°F / -40 to 204°C
Stainless steel (SST)	-40 to 650°F / -40 to 343°C

Maximum Temperature Ranges of Body Materials⁽¹⁾⁽²⁾

BODY AND SPRING CASE MATERIALS	TEMPERATURE RANGE
Gray Cast Iron	-20 to 406°F / -29 to 208°C
WCC steel ⁽⁴⁾	-20 to 650°F / -29 to 343°C
LCC steel ⁽⁴⁾	-40 to 650°F / -40 to 343°C
Stainless steel ⁽⁴⁾	-40 to 550°F / -40 to 288°C
Monel [®]	-40 to 550°F / -40 to 288°C
Hastelloy [®] C	-40 to 550°F / -40 to 288°C
Aluminum-Bronze	-40 to 500°F / -40 to 260°C

Spring Case Construction

Drilled Untapped Hole:

Standard for Types MR95L, MR95H, MR95HP and MR95HT

1/4 NPT Vent:

Standard for Types MR95LD and MR95HD
Optional for Types MR95L, MR95H, MR95HP and MR95HT

Pressure Setting Adjustment

Adjusting screw:

Standard for Types MR95L, MR95H, MR95HP and MR95HT only

Handwheel:

Standard for Types MR95LD and MR95HD
Optional for 1/2 in. / DN 15 body size of Types MR95L, MR95H, MR95HP and MR95HT

Tee handle:

Optional for other body sizes (except 1/2 in. / DN 15) of Types MR95L, MR95H, MR95HP and MR95HT

Pressure Registration

Internal or External

Typical Regulating Capacities

Air: See Tables 10, 11, 12, 13 and 14

Steam: See Tables 15, 16, 17, 18 and 19

Water: See Tables 20, 21, 22, 23 and 24

Shutoff Classification Per ANSI/FCI 70-3-2004

Metal Seats: Class IV

Elastomer Seats: Class VI or better

PTFE: Class IV

Flow and Sizing Coefficients

See Table 5

Relief Sizing Coefficients for MR95 Series Regulators with Reduced Flow Orifices

See Table 6

1. The pressure/temperature limits in this Bulletin, and any applicable standard or code limitation for this regulator should not be exceeded.
2. Pressures and/or the body end connection may decrease these maximum temperatures.
3. Fluorocarbon (FKM) is limited to 200°F / 93°C hot water.
4. Meets API 614 requirements (with Stainless steel trim).

- continued -

Specifications (continued)

Main Valve Construction Materials

See Table 8

Trim Materials

See Table 7

Product Dimension

See Figure 3

Common Services and Material Compatibility

See Table 9

Approximate Weights

MR95H Series

1/4 NPT body: 5 lbs / 2.3 kg

1/2 in. / DN 15 body: 10 lbs / 4.5 kg

3/4 and 1 in. / DN 20 and 25 bodies:

22 lbs / 10 kg

1-1/2 and 2 in. / DN 40 and 50 bodies:

55 lbs / 25 kg

MR95L Series

1/4 NPT body: 7 lbs / 3.2 kg

1/2 in. / DN 15 body: 15 lbs / 6.8 kg

3/4 and 1 in. / DN 20 and 25 bodies:

35 lbs / 16 kg

Introduction

The MR95 Series regulators are compact, large-capacity, direct-operated pressure regulators (see Figure 1). The units are available in 1/4 NPT through 2 in. / DN 50 sizes and are offered in several different end connection configurations. They are designed to handle pressures up to 1000 psig / 68.9 bar and temperatures up to 650°F / 343°C.

These products can help solve the toughest pressure control applications. Typical applications include superheated steam, steam injection, steam tracing, nitrogen purging, boiler feed water, process chemicals, cooling water, test fixtures, wash tanks, sterilizers/autoclaves, fuel lines, pneumatic supply and many others.

Features

- **Handwheels/Tee Handles**—Allow easy pressure setting changes and are standard on Types MR95LD and MR95HD, and optional on the Types MR95L, MR95H, MR95HP and MR95HT regulators.
- **Versatile**—Can be used with all process media including air, steam, gas, water, liquids (oils and process chemicals) and oxygen.
- **Tight Shutoff With Elastomer Seats**—Metal seats available for high temperatures.
- **Direct-Operated**—Design maximizes speed of response.
- **Robust**—Up to 1000 psig / 68.9 bar inlet pressure.
- **P₁ = P₂**—Inlet equals outlet rating in Types MR95H and MR95HD up to 300 psig / 20.7 bar.
- **Rugged Construction**—Available in a variety of body and spring case materials to address the toughest service conditions. Severe service elastomers and corrosion resistant trims are also available and provide excellent fluid compatibility.

- **Differential Pressure Capability**—Spring-loaded Polytetrafluoroethylene (PTFE) packing and tapped connections permit pressure loading of the Types MR95LD and MR95HD spring cases.
- **Special Service Capabilities**—Optional materials are available for applications handling sour gases, cryogenics and superheated steam.
- **Large Turndown Ratio**—No need for low C_v trims at low flows.
- **Graphite Gaskets**—For high temperature applications up to 650°F / 343°C (optional).
- **Set Pressures up to 400 psig / 27.6 bar**
- **Multiple End Connection Options**—To match your application.
- **Easy Maintenance**—Seating parts are easily accessible by removing the plug on the bottom of the regulator.
- **API 614 Compliant**—Steel and Stainless steel constructions meet API 614 requirements.

Principle of Operation

The MR95 Series (refer to Figure 2) is a direct-operated regulator. Downstream pressure is registered internally or externally through a control line to the under side of the diaphragm. When the downstream pressure is at or above the set pressure, the disk is held against the orifice, restricting fluid flow through the regulator. When demand increases, downstream pressure drops slightly allowing the spring to extend, moving the stem down and the disk away from the orifice. This allows fluid flow through the body to the downstream system. Types MR95H, MR95L, MR95HP and MR95HT use spring force to regulate outlet pressure. Types MR95HD and MR95LD use spring force to maintain a differential pressure between spring case loading pressure and outlet pressure.

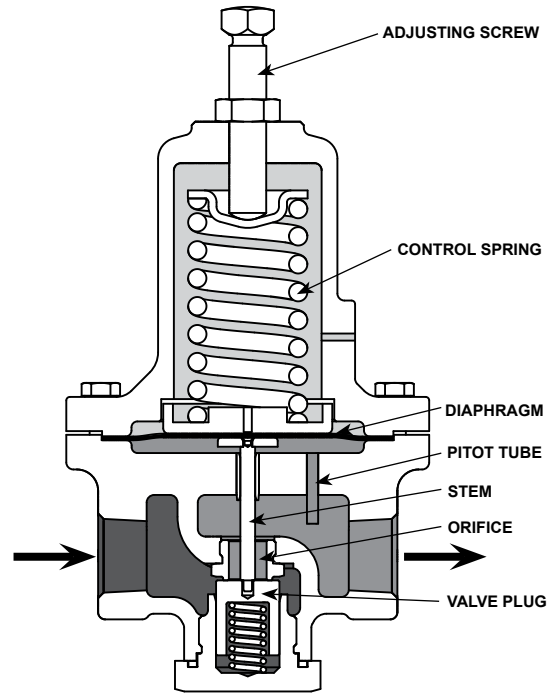

FRONT AND INTERNAL VIEW OF
TYPE MR95H WITH INTERNAL
PRESSURE REGISTRATION

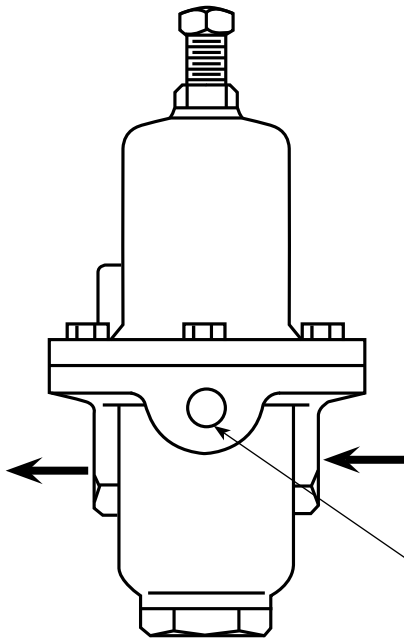

BACK VIEW OF
1/2 IN. / DN 15 TYPE MR95H
WITH EXTERNAL
PRESSURE REGISTRATION

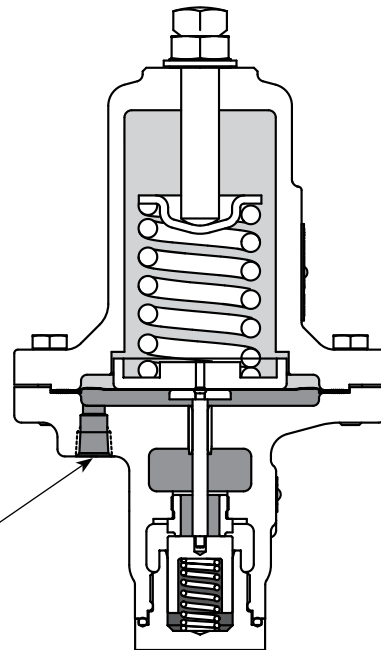

SIDE AND INTERNAL VIEW OF
3/4 TO 2 IN. / DN 20 TO 50
TYPE MR95H WITH EXTERNAL
PRESSURE REGISTRATION
(ALSO TYPICAL OF TYPE MR95L,
1/2 TO 2 IN. / DN 15 TO 50 BODIES)

- INLET PRESSURE
- OUTLET PRESSURE
- ATMOSPHERIC PRESSURE

Figure 2. MR95 Series Operational Schematics

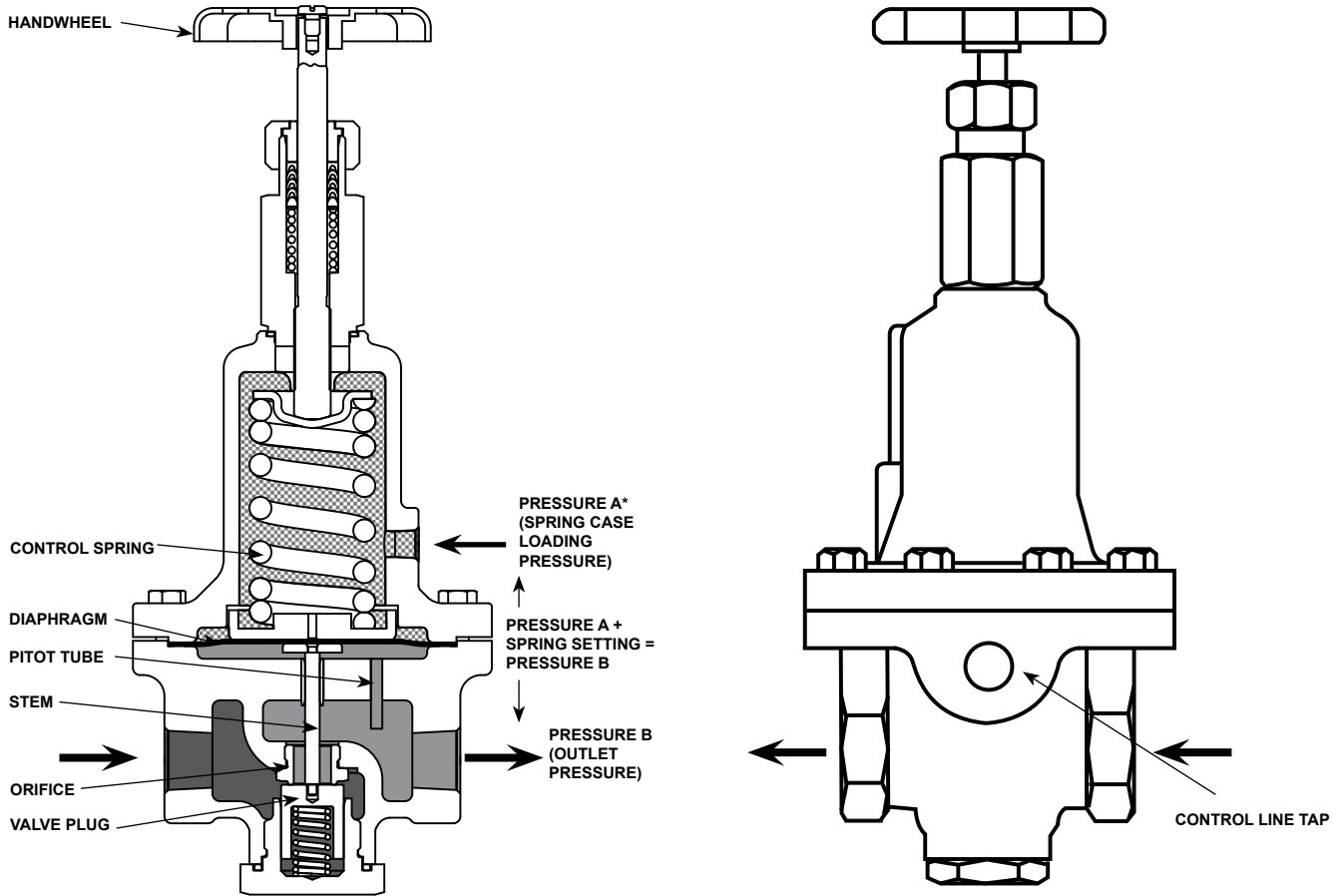

FRONT AND INTERNAL VIEW OF
TYPE MR95HD WITH INTERNAL PRESSURE REGISTRATION

BACK VIEW OF
TYPE MR95HD WITH EXTERNAL PRESSURE REGISTRATION

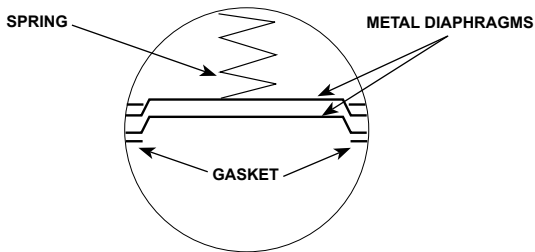

TYPE MR95H WITH 2 METAL DIAPHRAGMS (ALSO TYPICAL OF
TYPES MR95HT AND MR95L EXCEPT FOR TYPE MR95L WITH 1/4 NPT
BODY SIZE, 2 to 6 psi / 0.14 to 0.41 bar RANGE)

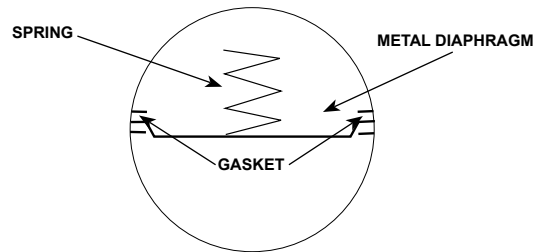

TYPE MR95L (1/4 NPT, 2 to 6 psi / 0.14 to 0.41 bar RANGE)
WITH METAL DIAPHRAGM

INLET PRESSURE
 OUTLET PRESSURE
 LOADING PRESSURE



*PRESSURE A MAY BE SUPPLIED BY ANOTHER PRESSURE SYSTEM OR A MANUAL LOADING REGULATOR.

Figure 2. MR95 Series Operational Schematics (continued)

Bulletin 71.1:MR95

Table 1. Types MR95L and MR95LD Regulators Body Constructions

BODY SIZE	BODY CONSTRUCTION	END CONNECTION	BODY MATERIAL				
			Gray Cast Iron	LCC or WCC Steel	CF8M Stainless Steel	CF3M Stainless Steel	Monel® or Hastelloy® C
1/4 NPT	Without Control Line and Gauge Port	NPT					
1/2 in. / DN 15	Without Control Line and Gauge Port	NPT					
		SWE					
		Welded CL150 RF					
		Welded CL300 RF					
		Welded PN 16/25/40 RF					
	With Control Line but Without Gauge Port	NPT					
		Welded CL150 RF					
		Welded CL300 RF					
		Welded PN 16/25/40 RF					
3/4 in. / DN 20	Without Control Line and Gauge Port	NPT					
		SWE					
		Welded CL150 RF					
		Welded CL300 RF					
	With Control Line but Without Gauge Port	NPT					
		Welded CL150 RF					
		Welded CL300 RF					
		Welded PN 16/25/40 RF					
	With Gauge Port but Without Control Line	NPT					
		Welded CL150 RF					
		Welded CL300 RF					
		Welded PN 16/25/40 RF					
	1 in. / DN 25	Without Control Line and Gauge Port	NPT				
SWE							
Welded CL150 RF							
Welded CL300 RF							
With Control Line but Without Gauge Port		NPT					
		Welded CL150 RF					
		Welded CL300 RF					
		Welded PN 16/25/40 RF					
With Gauge Port but Without Control Line		NPT					
		Welded CL150 RF					
		Welded CL300 RF					
		Welded PN 16/25/40 RF					

 - Shaded areas indicate that the construction is available.
 - Blank areas indicate that you need to contact your local Sales Office for the availability of the constructions.

Monel® is a mark owned by Special Metals Corporation.
 Hastelloy® C is a mark owned by Haynes International, Inc.

Table 2. Types MR95H, MR95HD, MR95HT and MR95HP Regulators Body Constructions

BODY SIZE	BODY CONSTRUCTION	END CONNECTION	BODY MATERIAL					
			Gray Cast Iron ⁽¹⁾	LCC or WCC Steel	CF8M Stainless Steel	CF3M Stainless Steel	Monel® or Hastelloy® C	Aluminum-Bronze
1/4 NPT	Without Gauge Port and Control Line	NPT						
1/2 in. / DN 15	Without Control Line and Gauge Port	NPT						
		SWE						
		Welded CL150 RF						
		Welded CL300 RF						
		Welded CL600 RF						
		Welded PN 16/25/40 RF						
		Integral CL150 RF						
		Integral CL300 RF						
		Integral CL600 RF						
		Integral PN 16/25/40 RF						
	With Control Line but Without Gauge Port	NPT						
		Welded CL150 RF						
		Welded CL300 RF						
		Welded CL600 RF						
Welded PN 16/25/60 RF								
3/4 in. / DN 20	Without Gauge Port and Control Line	NPT						
		SWE						
		Welded CL150 RF						
		Welded CL300 RF						
		Welded CL600 RF						
		Welded PN 16/25/40 RF						
	With Control Line but Without Gauge Port	NPT						
		Welded CL150 RF						
		Welded CL300 RF						
		Welded PN 16/25/60 RF						
	With Gauge Port but Without Control Line	NPT						
		Welded CL150 RF						
		Welded CL300 RF						
		Welded PN 16/25/60 RF						
1 in. / DN 25	Without Gauge Port and Control Line	NPT						
		SWE						
		Welded CL150 RF						
		Welded CL300 RF						
		Welded CL600 RF						
		Welded PN 16/25/40 RF						
		Integral CL150 RF						
		Integral CL300 RF						
		Integral CL600 RF						
		Integral PN 16/25/40 RF						

■ - Shaded areas indicate that the construction is available.

□ - Blank areas indicate that you need to contact your local Sales Office for the availability of the constructions.

1. Gray cast iron body material is available for Types MR95H and MR95HD only.



- continued -

Monel® is a mark owned by Special Metals Corporation.
Hastelloy® C is a mark owned by Haynes International, Inc.

Bulletin 71.1:MR95

Table 2. Types MR95H, MR95HD, MR95HT and MR95HP Regulators Body Constructions (continued)

BODY SIZE	BODY CONSTRUCTION	END CONNECTION	BODY MATERIAL						
			Gray Cast Iron ⁽¹⁾	LCC or WCC Steel	CF8M Stainless Steel	CF3M Stainless Steel	Monel® or Hastelloy® C	Aluminum-Bronze	
1 in. / DN 25	With Control Line but Without Gauge Port	NPT							
		Welded CL150 RF							
		Welded CL300 RF							
		Welded PN 16/25/40 RF							
	With Gauge Port but Without Control Line	NPT							
		Welded CL150 RF							
		Welded CL300 RF							
		Welded PN 16/25/40 RF							
1-1/2 in. / DN 40	Without Gauge Port and Control Line	NPT							
		SWE							
		Welded CL150 RF							
		Welded CL300 RF							
		Welded CL600 RF							
	Welded PN 16/25/40 RF								
	With Control line but Without Gauge Port	NPT							
		Welded CL150 RF							
		Welded CL300 RF							
	With Gauge Port but Without Control Line	Welded PN 16/25/40 RF							
		NPT							
		Welded CL150 RF							
		Welded CL300 RF							
	2 in. / DN 50	Without Gauge Port and Control Line	Welded PN 16/25/40 RF						
			NPT						
			SWE						
Welded CL150 RF									
Welded CL300 RF									
Welded CL600 RF									
Welded PN 16/25/40 RF									
Integral CL150 RF									
Integral CL300 RF									
Integral CL600 RF									
Integral PN 16/25/40 RF									
With Control Line but Without Gauge Port		NPT							
		Welded CL150 RF							
		Welded CL300 RF							
With Gauge Port but Without Control Line		Welded PN 16/25/40 RF							
		NPT							
	Welded CL150 RF								
	Welded CL300 RF								
Welded PN 16/25/40 RF									

 - Shaded areas indicate that the construction is available.
 - Blank areas indicate that you need to contact your local Sales Office for the availability of the constructions.
 1. Gray cast iron body material is available for Types MR95H and MR95HD only.

Monel® is a mark owned by Special Metals Corporation.
 Hastelloy® C is a mark owned by Haynes International, Inc.

Table 3. Body Sizes, Pressure Ranges and Spring Information

TYPE	BODY SIZE		OUTLET OR DIFFERENTIAL PRESSURE RANGE ⁽¹⁾		SPRING WIRE DIAMETER		SPRING FREE LENGTH		SPRING MATERIAL ⁽²⁾	SPRING PART NUMBER	SPRING COLOR
	In.	DN	psi/psig	bar	In.	mm	In.	mm			
MR95L and MR95LD	1/4	----	2 to 6	0.14 to 0.41	0.148	3.76	2.00	50.8	Zinc-plated steel	1E392527022	Yellow
			5 to 15	0.34 to 1.0	0.170	4.32	2.00	50.8	Zinc-plated steel	ERAA01888A0	Green
			13 to 30	0.90 to 2.1	0.207	5.26	1.94	49.2	Powder-coated steel	ERAA01889A0	Red
	1/2	15	2 to 6	0.14 to 0.41	0.207	5.26	2.50	63.5	Powder-coated steel	ERCA04288A0	Yellow
			5 to 15	0.34 to 1.0	0.234	5.94	2.60	65.9	Powder-coated steel	ERAA01910A0	Green
			13 to 30	0.90 to 2.1	0.283	7.19	2.44	62.0	Powder-coated steel	ERAA01911A0	Red
	3/4 and 1	20 and 25	2 to 6	0.14 to 0.41	0.306	7.77	4.00	102	Powder-coated steel	1E398927022	Yellow
			5 to 15	0.34 to 1.0	0.343	8.71	4.00	102	Powder-coated steel	1E399027142	Green
			13 to 30	0.90 to 2.1	0.406	10.31	4.00	102	Powder-coated steel	1E399127162	Red
	3/4 and 1	20 and 25	2 to 6	0.14 to 0.41	0.306	7.77	4.00	102	Powder-coated Stainless steel	1E3989X0052	Yellow
			5 to 15	0.34 to 1.0	0.375	9.53	3.88	98.6	Stainless steel	1K762537022	Unpainted
			13 to 30	0.90 to 2.1	0.437	11.1	4.00	102	Stainless steel	11A8269X012	Unpainted
MR95H and MR95HD	1/4	----	15 to 30	1.0 to 2.1	0.148	3.76	2.00	50.8	Zinc-plated steel	1E392527022	Yellow
			25 to 75	1.7 to 5.2	0.170	4.32	2.00	50.8	Zinc-plated steel	ERAA01888A0	Green
			70 to 150	4.8 to 10.3	0.207	5.26	1.94	49.2	Powder-coated steel	ERAA01889A0	Red
	1/2	15	15 to 30	1.0 to 2.1	0.207	5.26	2.50	63.5	Powder-coated steel	ERCA04288A0	Yellow
			25 to 75	1.7 to 5.2	0.234	5.94	2.60	65.9	Powder-coated steel	ERAA01910A0	Green
			70 to 150	4.8 to 10.3	0.283	7.19	2.44	62.0	Powder-coated steel	ERAA01911A0	Red
	3/4 and 1	20 and 25	15 to 30	1.0 to 2.1	0.306	7.77	4.00	102	Powder-coated steel	1E398927022	Yellow
			25 to 75	1.7 to 5.2	0.343	8.71	4.00	102	Powder-coated steel	1E399027142	Green
			70 to 150	4.8 to 10.3	0.406	10.31	4.00	102	Powder-coated steel	1E399127162	Red
	3/4 and 1	20 and 25	15 to 30	1.0 to 2.1	0.306	7.77	4.00	102	Powder-coated Stainless steel	1E3989X0052	Yellow
			25 to 75	1.7 to 5.2	0.375	9.53	3.88	98.6	Stainless steel	1K762537022	Unpainted
			70 to 150	4.8 to 10.3	0.437	11.1	4.00	102	Stainless steel	11A8269X012	Unpainted
1-1/2 and 2	40 and 50	5 to 80	0.34 to 5.5	0.500	12.7	6.50	165	Powder-coated steel	ERCA04290A0	Black with Light Blue Stripe	
		60 to 120	4.1 to 8.3	0.562	14.3	6.56	167	Powder-coated steel	ERAA01893A0	Light Gray	
		100 to 140	6.9 to 9.7	0.594	15.1	6.56	167	Enamel-coated steel	ERAA01894A0	Yellow	
		120 to 150	8.3 to 10.3	0.625	15.9	6.57	167	Powder-coated steel	1P7888X0022	Black	
MR95HT	1/4	----	15 to 100	1.0 to 6.9	0.192	4.88	2.00	50.8	Inconel®	ERCA04292A0	Unpainted
			80 to 300	5.5 to 20.7	0.281	7.14	2.00	50.8	Inconel®	ERCA04291A0	Unpainted
	1/2	15	15 to 100	1.0 to 6.9	0.281	7.14	2.50	63.5	Inconel®	ERCA04294A0	Unpainted
			80 to 300	5.5 to 20.7	0.375	9.53	2.60	66.0	Inconel®	ERCA04293A0	Unpainted
	3/4 and 1	20 and 25	15 to 100	1.0 to 6.9	0.437	11.1	4.08	104	17-4 PH Stainless steel	ERCA04295A0	Unpainted
			80 to 300	5.5 to 20.7	0.562	14.3	4.08	104	17-4 PH Stainless steel	ERCA04296A0	Unpainted
1-1/2 and 2	40 and 50	15 to 100	1.0 to 6.9	0.625	15.9	6.70	170	17-4 PH Stainless steel	ERCA04297A0	Unpainted	
60 to 260	4.1 to 17.9	0.812	20.6	6.70	170	17-4 PH Stainless steel	ERCA04298A0	Unpainted			
MR95HP	1/4	----	15 to 100	1.0 to 6.9	0.192	4.88	2.00	50.8	Inconel®	ERCA04292A0	Unpainted
			80 to 400	5.5 to 27.6	0.281	7.14	2.00	50.8	Inconel®	ERCA04291A0	Unpainted
	1/2	15	15 to 100	1.0 to 6.9	0.281	7.14	2.50	63.5	Inconel®	ERCA04294A0	Unpainted
			80 to 400	5.5 to 27.6	0.375	9.53	2.60	66.0	Inconel®	ERCA04293A0	Unpainted
	3/4 and 1	20 and 25	15 to 100	1.0 to 6.9	0.437	11.1	4.08	104	17-4 PH Stainless steel	ERCA04295A0	Unpainted
			80 to 400	5.5 to 27.6	0.562	14.3	4.08	104	17-4 PH Stainless steel	ERCA04296A0	Unpainted
1-1/2 and 2	40 and 50	15 to 100	1.0 to 6.9	0.625	15.9	6.70	170	17-4 PH Stainless steel	ERCA04297A0	Unpainted	
60 to 300	4.1 to 20.7	0.812	20.6	6.70	170	17-4 PH Stainless steel	ERCA04298A0	Unpainted			

1. For Types MR95LD and MR95HD regulators, the pressure ranges indicate the differential pressure that can be obtained with the indicated spring. The differential pressure (spring setting) is added to the spring case loading pressure to determine the actual outlet pressure.
 2. Springs meet NACE MR0175-2002 and NACE MR0103 requirements only for applications in which the spring is not exposed to the sour gas.

Bulletin 71.1:MR95

Table 4. Maximum Cold Working Pressures of Body Size and Material⁽¹⁾⁽²⁾

TYPE	BODY SIZE	BODY MATERIAL	MAXIMUM INLET PRESSURE		MAXIMUM OUTLET PRESSURE		MAXIMUM SPRING CASE PRESSURE	
			psig	bar	psig	bar	psig	bar
MR95L and MR95LD	All available sizes ⁽³⁾	Gray Cast Iron	250	17.2	50	3.4	50	3.4
		WCC Steel	300	20.7	125	8.6	125	8.6
		LCC Steel	300	20.7	125	8.6	125	8.6
		CF8M Stainless steel	300	20.7	125	8.6	125	8.6
		CF3M Stainless steel	300	20.7	125	8.6	125	8.6
		Monel ^{®(4)}	300	20.7	125	8.6	125	8.6
MR95H and MR95HD	All available sizes ⁽³⁾	Gray Cast Iron	250	17.2	250	17.2	250	17.2
		WCC Steel	300	20.7	300	20.7	300	20.7
		LCC Steel	300	20.7	300	20.7	300	20.7
		CF8M Stainless steel	300	20.7	300	20.7	300	20.7
		CF3M Stainless steel	300	20.7	300	20.7	300	20.7
		Monel ^{®(4)}	300	20.7	300	20.7	300	20.7
MR95HP	All available sizes ⁽³⁾	Hastelloy [®] C ⁽⁴⁾	300	20.7	300	20.7	300	20.7
		Aluminum-Bronze ⁽⁴⁾	300	20.7	300	20.7	300	20.7
		WCC Steel	1000	68.9	600	41.4	300	20.7
		LCC Steel	1000	68.9	600	41.4	300	20.7
		CF8M Stainless steel	1000	68.9	550	37.9	300	20.7
		CF3M Stainless steel	1000	68.9	550	37.9	300	20.7
MR95HT	1/4 NPT and 1/2 to 1 in. / DN 15 to 25	Monel ^{®(4)}	1000	68.9	550	37.9	300	20.7
		Hastelloy [®] C ⁽⁴⁾	1000	68.9	550	37.9	300	20.7
		Aluminum-Bronze ⁽⁴⁾	1000	68.9	550	37.9	300	20.7
		WCC Steel	600	41.4	600	41.4	300	20.7
		LCC Steel	600	41.4	600	41.4	300	20.7
		CF8M Stainless steel	600	41.4	550	37.9	300	20.7
	1-1/2 and 2 in. / DN 40 and 50	CF3M Stainless steel	600	41.4	550	37.9	300	20.7
		Monel [®]	600	41.4	550	37.9	300	20.7
		Hastelloy [®] C	600	41.4	450	31.0	300	20.7
		Aluminum-Bronze	600	41.4	450	31.0	300	20.7
		WCC Steel	600	41.4	450	31.0	300	20.7
		LCC Steel	600	41.4	450	31.0	300	20.7

1. The pressure/temperature limits in this Bulletin and any applicable standard or code limitation should not be exceeded.
2. The pressure limits given are based on the body size and body materials only. Actual pressure limits of the assembled regulator may decrease and vary depending on the temperature, body end connection, diaphragm, seat and/or trim material of the regulator.
3. See Tables 1 and 2 for all available body sizes.
4. Not available for 1/4 NPT body size.

Table 5. Flow and Sizing Coefficients for all MR95 Series Regulators

BODY SIZE		WIDE-OPEN COEFFICIENTS (FOR RELIEF SIZING)			C ₁	K _m	IEC SIZING COEFFICIENTS		
In.	DN	C _v	C _g	C _s			X _T	F _D	F _L
1/4	----	1.1	37	1.85	33.6	0.74	0.715	0.62	0.86
1/2	15	2.9	103	5.15	35.5	0.79	0.797	0.70	0.89
3/4 and 1	20 and 25	6.0	221	11.05	36.8	0.88	0.857	0.68	0.94
1-1/2 and 2	40 and 50	18.1	700	35.00	38.7	0.88	0.945	0.65	0.94

K_m = F_L²

Table 6. Relief Sizing Coefficients for MR95 Series Regulators with Reduced Flow Orifices⁽¹⁾

BODY SIZE		WIDE-OPEN COEFFICIENTS FOR MR95 SERIES REDUCED FLOW OPTION	WIDE-OPEN COEFFICIENTS FOR LEGACY 95 SERIES
In.	DN	C _g	C _g
1/4	----	28	28
1/2	15	70	67
3/4 and 1	20 and 25	156	156
1-1/2 and 2	40 and 50	482	475

1. The reduced flow orifice option offers similar flow capacity as the equivalent 95 series configuration.

Monel[®] is a mark owned by Special Metals Corporation.
Hastelloy[®] C is a mark owned by Haynes International, Inc.

Table 7. MR95 Series Trim Materials

TYPE	TRIM NUMBER	SEAT	ORIFICE / VALVE PLUG	VALVE PLUG GUIDE	STEM / STEM GUIDE	VALVE SPRING
MR95L, MR95LD, MR95H and MR95HD	1	416 Stainless steel	416 Stainless steel	Brass ⁽³⁾	416 Stainless steel	302 Stainless steel
	2	416 Stainless steel	416 Stainless steel	416 Stainless steel	416 Stainless steel	302 Stainless steel
	3	316 Stainless steel	316 Stainless steel	316 Stainless steel	316 Stainless steel	302 Stainless steel
	4	Alloy 6 ⁽¹⁾	Alloy 6 ⁽¹⁾	316 Stainless steel	316 Stainless steel	302 Stainless steel
	5	Hastelloy® C	Hastelloy® C	Hastelloy® C	Hastelloy® C	Inconel®
	6	Monel®	Monel®	Monel®	Monel®	Inconel®
	7	Nitrile (NBR)	Brass ⁽²⁾	Brass ⁽³⁾	416 Stainless steel	302 Stainless steel
	8	Nitrile (NBR)	Brass ⁽²⁾	416 Stainless steel	416 Stainless steel	302 Stainless steel
	9	Nitrile (NBR)	316 Stainless steel	316 Stainless steel	316 Stainless steel	302 Stainless steel
	10	Nitrile (NBR)	416 Stainless steel	416 Stainless steel	416 Stainless steel	302 Stainless steel
	11	Nitrile (NBR)	416 Stainless steel	Brass ⁽³⁾	416 Stainless steel	302 Stainless steel
	12	Fluorocarbon (FKM)	Brass ⁽²⁾	Brass ⁽³⁾	416 Stainless steel	302 Stainless steel
	13	Fluorocarbon (FKM)	316 Stainless steel	316 Stainless steel	316 Stainless steel	302 Stainless steel
	14	Fluorocarbon (FKM)	416 Stainless steel	416 Stainless steel	416 Stainless steel	302 Stainless steel
	15	Fluorocarbon (FKM)	Monel®	Monel®	Monel®	Inconel®
	16	Perfluoroelastomer (FFKM)	316 Stainless steel	316 Stainless steel	316 Stainless steel	302 Stainless steel
	17	Polytetrafluoroethylene (PTFE)	Brass ⁽²⁾	Brass ⁽³⁾	416 Stainless steel	302 Stainless steel
	18	Polytetrafluoroethylene (PTFE)	316 Stainless steel	316 Stainless steel	316 Stainless steel	302 Stainless steel
	19	Polytetrafluoroethylene (PTFE)	416 Stainless steel	416 Stainless steel	416 Stainless steel	302 Stainless steel
	20	Ethylenepropylene (EPDM)	416 Stainless steel	416 Stainless steel	416 Stainless steel	302 Stainless steel
MR95HT	22	416 Stainless steel	416 Stainless steel	416 Stainless steel	416 Stainless steel	Inconel®
	23	316 Stainless steel	316 Stainless steel	316 Stainless steel	316 Stainless steel	Inconel®
	24	Alloy 6 ⁽¹⁾	Alloy 6 ⁽¹⁾	316 Stainless steel	316 Stainless steel	Inconel®
MR95HP	10	Nitrile (NBR)	416 Stainless steel	416 Stainless steel	416 Stainless steel	302 Stainless steel
	14	Fluorocarbon (FKM)	416 Stainless steel	416 Stainless steel	416 Stainless steel	302 Stainless steel

1. Alloy 6 is not available for 1/4 NPT body.
2. 1/4 NPT has brass orifice and 316 Stainless steel valve plug.
3. 1-1/2 and 2 in. / DN 40 and 50 bodies have 416 Stainless steel valve plug guide.

Table 8. MR95 Series Construction Materials

MAIN VALVE MATERIAL		
Body	Spring Case	Regulator Spring
Gray Cast Iron LCC/WCC Steel CF8M/CF3M Stainless steel Hastelloy® C Monel® Aluminum-Bronze	Gray Cast Iron ⁽¹⁾ LCC/WCC Steel CF8M Stainless steel Hastelloy® C Monel®	Steel (standard) Inconel® 302 Stainless steel 17-4 PH Stainless steel

1. Gray cast iron spring case is not available for Types MR95LD and MR95HD.

TRIM MATERIAL		
Elastomer Seat		
Part Name	Standard	Optional
Diaphragm	Neoprene (CR)	302 Stainless steel ⁽¹⁾ , Fluorocarbon (FKM) ⁽²⁾ , Ethylenepropylene (EPDM) ⁽²⁾ , Monel ^{®(1)} , Hastelloy® C ⁽¹⁾ or PTFE protector available with Neoprene (CR) and Fluorocarbon (FKM) ⁽²⁾ diaphragm
Disk	Nitrile (NBR)	Fluorocarbon (FKM), Polytetrafluoroethylene (PTFE), Ethylenepropylene (EPDM) or Perfluoroelastomer (FFKM)
Disk Holder	Brass or 416 Stainless steel	316 Stainless steel, Monel® or Hastelloy® C
Valve Plug Guide	Brass or 416 Stainless steel	316 Stainless steel, Monel® or Hastelloy® C
Orifice	Brass or 416 Stainless steel	316 Stainless steel, Monel® or Hastelloy® C
Stem Assembly	416 Stainless steel	316 Stainless steel, Monel® or Hastelloy® C
Metal Seat		
Diaphragm	302 Stainless steel ⁽¹⁾	Monel ^{®(1)} , Hastelloy® C ⁽¹⁾ , Fluorocarbon (FKM) ⁽²⁾ , Ethylenepropylene (EPDM) ⁽²⁾ or PTFE protector available with Neoprene (CR) and Fluorocarbon (FKM) ⁽²⁾ diaphragm
Valve Plug	416 Stainless steel	316 Stainless steel, Monel®, Hastelloy® C or Alloy 6
Valve Plug Guide	Brass or 416 Stainless steel	316 Stainless steel, Monel® or Hastelloy® C
Orifice	416 Stainless steel	316 Stainless steel, Monel®, Hastelloy® C or Alloy 6
Stem Assembly	416 Stainless steel	316 Stainless steel, Monel® or Hastelloy® C
Gasket	Composition	Graphite

1. Two Diaphragms are used for metal diaphragm except Types MR95L and MR95LD 1/4 NPT Body, range 2 to 6 psig / 0.14 to 0.41 bar.
2. Two Diaphragms are used.

Inconel® is a mark owned by Special Metals Corporation.
 Monel® is a mark owned by Special Metals Corporation.
 Hastelloy® C is a mark owned by Haynes International, Inc.

Bulletin 71.1:MR95

Table 9. Chemical Compatibility

CORROSION INFORMATION															
Fluid	Material							Fluid	Material						
	Carbon Steel	Gray Cast Iron	302 or 304 Stainless Steel	316 Stainless Steel	416 Stainless Steel	Monel®	Hastelloy® C		Carbon Steel	Gray Cast Iron	302 or 304 Stainless Steel	316 Stainless Steel	416 Stainless Steel	Monel®	Hastelloy® C
Acetic Acid, Air Free	C	C	B	B	C	B	A	Hydrochloric Acid (Air free)	C	C	C	C	C	C	B
Acetic Acid Vapors	C	C	A	A	C	B	A	Hydrogen	A	A	A	A	A	A	A
Acetone	A	A	A	A	A	A	A	Hydrogen Peroxide	I.L.	A	A	A	B	A	A
Acetylene	A	A	A	A	A	A	A	Hydrogen Sulfide, Liquid	C	C	A	A	C	C	A
Alcohols	A	A	A	A	A	A	A	Magnesium Hydroxide	A	A	A	A	A	A	A
Aluminum Sulfate	C	C	A	A	C	B	A	Methanol	A	A	A	A	A	A	A
Ammonia	A	A	A	A	A	A	A	Methyl Ethyl Ketone	A	A	A	A	A	A	A
Ammonium Chloride	C	C	B	B	C	B	A	Natural Gas	A	A	A	A	A	A	A
Ammonium Nitrate	A	C	A	A	C	C	A	Nitric Acid	C	C	A	B	C	C	B
Ammonium Sulfate	C	C	B	A	C	A	A	Petroleum Oils, Refined	A	A	A	A	A	A	A
Ammonium Sulfite	C	C	A	A	B	C	A	Phosphoric Acid (Air Free)	C	C	A	A	C	B	A
Beer	B	B	A	A	B	A	A	Phosphoric Acid Vapors	C	C	B	B	C	C	I.L.
Benzene (Benzol)	A	A	A	A	A	A	A	Potassium Chloride	B	B	A	A	C	B	A
Benzoic Acid	C	C	A	A	A	A	A	Potassium Hydroxide	B	B	A	A	B	A	A
Boric Acid	C	C	A	A	B	A	A	Propane	A	A	A	A	A	A	A
Butane	A	A	A	A	A	A	A	Silver Nitrate	C	C	A	A	B	C	A
Calcium Chloride (Alkaline)	B	B	C	B	C	A	A	Sodium Acetate	A	A	B	A	A	A	A
Carbon Dioxide, Dry	A	A	A	A	A	A	A	Sodium Carbonate	A	A	A	A	B	A	A
Carbon Dioxide, Wet	C	C	A	A	A	A	A	Sodium Chloride	C	C	B	B	B	A	A
Carbon Disulfide	A	A	A	A	B	B	A	Sodium Chromate	A	A	A	A	A	A	A
Carbon Tetrachloride	B	B	B	B	C	A	A	Sodium Hydroxide	A	A	A	A	B	A	A
Carbonic Acid	C	C	B	B	A	A	A	Stearic Acid	A	C	A	A	B	B	A
Chlorine Gas, Dry	A	A	B	B	C	A	A	Sulfur	A	A	A	A	A	A	A
Chlorine Gas, Wet	C	C	C	C	C	C	B	Sulfur Dioxide, Dry	A	A	A	A	B	A	A
Chlorine, Liquid	C	C	C	C	C	C	A	Sulfur Trioxide, Dry	A	A	A	A	B	A	A
Chromic Acid	C	C	C	B	C	A	A	Sulfuric Acid (Aerated)	C	C	C	C	C	C	A
Citric Acid	I.L.	C	B	A	B	B	A	Sulfuric Acid (Air Free)	C	C	C	C	C	B	A
Coke Oven Gas	A	A	A	A	A	B	A	Sulfurous Acid	C	C	B	B	C	C	A
Copper Sulfate	C	C	B	B	A	C	A	Trichloroethylene	B	B	B	A	B	A	A
Ether	B	B	A	A	A	A	A	Water, Boiler Feed	B	C	A	A	B	A	A
Ethyl Chloride	C	C	A	A	B	A	A	Water, Distilled	A	A	A	A	A	A	A
Ethylene	A	A	A	A	A	A	A	Water, Sea	B	B	B	B	C	A	A
Ethylene Glycol	A	A	A	A	A	A	I.L.	Zinc Chloride	C	C	C	C	C	C	A
Formaldehyde	B	B	A	A	A	A	A	Zinc Sulfate	C	C	A	A	B	A	A
Formic Acid	I.L.	C	B	B	C	A	A								
Freon, Wet	B	B	B	A	I.L.	A	A								
Freon, Dry	B	B	A	A	I.L.	A	A								
Gasoline, Refined	A	A	A	A	A	A	A	----	----	----	----	----	----	----	----
Glucose	A	A	A	A	A	A	A								
Hydrochloric Acid (Aerated)	C	C	C	C	C	C	B								
FLUID INFORMATION															
Fluid	Neoprene (CR)	Nitrile (NBR)	Fluorocarbon (FKM)	EPDM	Fluid	Neoprene (CR)	Nitrile (NBR)	Fluorocarbon (FKM)	EPDM						
Acetic Acid (30%)	C	B	B	A	Freon 22	A+	C	C	A						
Acetone	B	C	C	A	Freon 114	A	A	B	A						
Alcohol, Ethyl	A	A	B	A	Gasoline	B	A+	A	C						
Alcohol, Methyl	A+	A	C	A	Hydrogen Gas	A	A	A	A						
Ammonia, Anhydrous	A	C	C	A	Hydrogen Sulfide (Dry)	A	C	C	A						
Ammonia, Gas, (Hot)	B	C	C	B	Hydrogen Sulfide (Wet)	B	C	C	A						
Benzene	C	C	A	C	Jet Fuel (JP-4)	C	A	A	I.L.						
Brine (Calcium Chloride)	A	A	B	A	Natural Gas	A	A+	A	C						
Butadiene Gas	B	C	B	C	Natural Gas + H ₂ S (Sour Gas)	A	B	C	C						
Butane, Gas	A	A+	A	C	Nitric Acid (10%)	B	C	A	C						
Butane, Liquid	B	A	A	C	Nitric Acid (50 to 100%)	C	C	A	C						
Carbon Tetrachloride	C	C	A	C	Nitrogen	A	A	A	A						
Chlorine, Dry	C	C	A	C	Oil (Fuel)	B	A+	A	C						
Chlorine, Wet	C	C	A	C	Propane	A	A	A	C						
Coke Oven Gas	C	B	A+	C	Sea Water	B	A	A	A						
Ethyl Acetate	C	C	C	B	Sulfur Dioxide	A	C	A	A						
Ethylene Glycol	A	A	A	A	Sulfuric Acid (to 50%)	B	C	A	B						
Freon 11	B	A	A+	C	Sulfuric Acid (50 to 100%)	C	C	A	B						
Freon 12	A+	A	B	B	Water (Ambient)	A	A	A	A						
					Water at 200°F / 93°C	C	B	B	A						

A+—Best possible selection
A—Recommended
B—Minor to moderate effect. Proceed with caution.
C—Unsatisfactory
I.L.—Information lacking

Monel® is a mark owned by Special Metals Corporation.
Hastelloy® C is a mark owned by Haynes International, Inc.

Installation

The MR95 Series regulators may be installed in any position, as long as flow will be in the same direction as that indicated by the body arrow. The Types MR95H, MR95L, MR95HT and MR95HP regulators should be installed so that their spring case vents are protected from anything that might clog them.

Emerson Process Management Regulator Technologies, Inc. (Emerson™) provides an instruction manual with every regulator shipped. Refer to this for complete installation, operation and maintenance instructions. Included is a complete list of individual parts and recommended spare parts.

Universal NACE Compliance

Optional materials are available for applications handling sour gases. These constructions comply with the recommendations of NACE International sour service standards.

The manufacturing processes and materials used by Emerson assure that all products specified for sour gas service comply with the chemical, physical and metallurgical requirements of NACE MR0175 ISO-2002 and/or NACE MR0103. Optional materials are available to meet ANSI/NACE MR0175/ISO 15156, please contact your local Sales Office for special ordering instructions. Customers have the responsibility to specify correct materials. Environmental limitations may apply and shall be determined by the user.

Capacity Data

The capacity information on the following pages is based on three droop factors, 10%, 20% and 40%. Droop is deviation from the setpoint of the regulator, and is usually stated in percentage of setpoint value.

For highest capacity and the most accurate control within a particular type of the MR95 Series regulators, use the lowest range spring that can be adjusted to the desired setpoint (see Table 3 for part numbers of appropriate springs for each body size).

If closer control is necessary, a regulator of larger capacity or different design should be selected, so that the necessary flow can be obtained with a smaller droop factor.

Sometimes it may be necessary to interpolate the capacity table data to determine capacity for outlet settings not given. To maintain accuracy, it is important when interpolating to stay within a spring range if possible. The following is a procedure for interpolating the data to calculate flow:

1. Determine which spring is to be used.
2. Find the two outlet settings (P_{2a} and P_{2b}) that bracket the actual outlet pressure P_2 .
3. For a given body size and inlet pressure, find the capacity Q_a for P_{2a} and Q_b for P_{2b} .

4. Use the following formula to determine the interpolated capacity (Q):

$$\frac{Q_b - Q_a}{P_{2b} - P_{2a}} = \frac{Q_b - Q}{P_{2b} - P_2}$$

Example:

$P_1 = 100$ psig / 6.9 bar

1/4 NPT Type MR95H with 15 to 30 psig / 1.0 to 2.1 bar spring range

$P_2 = 20$ psig / 1.4 bar

Determine air capacity, Q

Solution:

$Q_a = 1100$ SCFH / 28.8 Nm³/h

$P_{2a} = 15$ psig / 1.0 bar

$Q_b = 1700$ SCFH / 46.5 Nm³/h

$P_{2b} = 30$ psig / 2.1 bar

$$\frac{1700 - 1100}{30 - 15} = \frac{1700 - Q}{30 - 20}$$

$Q = 1300$ SCFH

$$\frac{46.5 - 28.8}{2.1 - 1.0} = \frac{46.5 - Q}{2.1 - 1.4}$$

$Q = 35$ Nm³/h

Note

The same interpolation procedure can be used for different inlet pressures.

Contact your local Sales Office if you should have any questions about selecting the proper regulator.

Air Capacities

Regulating capacities at selected pressures and outlet pressure flows are given in SCFH (60°F and 14.7 psia) of air. To determine the equivalent capacities for other gases, multiply the table capacities by the following appropriate conversion factors: 1.29 for 0.6 specific gravity natural gas, 0.808 for propane, 0.707 for butane or 1.018 for nitrogen. For gases of other specific gravities, divide by the square root of the appropriate specific gravity.

Then, if capacity is desired in Nm³/h at 0°C and 1.01325 bar, multiply SCFH by 0.0268.

Capacities in Tables 10, 11, 12, 13 and 14 are for regulators using elastomer diaphragms. Depending on regulator construction, a multiplier must be used to convert to capacities for regulators using metal diaphragms.

Bulletin 71.1:MR95

Table 10. Air Capacities⁽¹⁾⁽²⁾ in SCFH / Nm³/h for 1/4 NPT and 1/2 through 1 in. / DN 15 through 25 Types MR95L and MR95LD Regulators with Elastomer Diaphragm

RECOMMENDED OUTLET/ DIFFERENTIAL PRESSURE RANGE, psig/psi / bar	PRESSURE				REGULATOR BODY SIZE, IN. / DN															
	Outlet/ Differential Setting		Inlet		1/4 NPT				1/2 /15				3/4 / 20				1 / 25			
					Droop		Droop		Droop		Droop									
	psig	bar	psig	bar	10%		20%		10%		20%		10%		20%		10%		20%	
SCFH					Nm ³ /h	SCFH	Nm ³ /h	SCFH	Nm ³ /h	SCFH	Nm ³ /h	SCFH	Nm ³ /h	SCFH	Nm ³ /h	SCFH	Nm ³ /h	SCFH	Nm ³ /h	
2 to 6 / 0.14 to 0.41	5	0.34	20	1.4	740	19.8	910	24.5	1000	27.2	1500	41.2	1200	32.8	2200	59.5	2800	74.7	4600	124
			30	2.1	950	25.4	1100	30.2	1100	28.9	1600	42.7	1400	37.8	2500	67.9	3300	87.5	5200	139
			50	3.4	1400	36.5	1500	41.5	1200	32.4	1700	45.5	1800	47.7	3200	84.7	4200	113	6300	169
			75	5.2	1600	43.3	1700	46.9	1300	34.1	1800	47.5	2300	60.5	3500	94.7	4400	118	6700	180
			100	6.9	1800	48.3	1900	52.2	1300	35.9	1800	49.5	2700	73.3	3900	105	4600	123	7100	191
			150	10.3	1800	48.3	2000	53.6	1500	39	2000	52.6	2400	65	4000	106	4600	123	7400	197
			200	13.8	1800	48.3	2000	53.6	1600	42.1	2100	55.6	2100	56.7	4000	107	4600	122	7600	203
			250	17.2	1800	48.3	2000	53.6	1500	41	2100	56.4	2000	52.8	3800	102	4900	131	7900	212
5 to 15 / 0.34 to 1.0	10	0.69	20	1.4	670	18.1	930	24.9	1200	31.8	1900	50.6	1700	45.2	2700	72.7	3000	80.1	4700	127
			30	2.1	950	25.5	1200	31.6	1300	36	2000	54.9	1900	52.1	3100	82.8	3600	97.1	5800	156
			50	3.4	1500	40.4	1700	44.9	1700	44.3	2400	63.5	2500	66.1	3800	103	4900	131	8000	215
			75	5.2	1800	48.5	2000	53.3	1700	46.7	2500	67.7	2800	76	4300	115	5700	153	8700	234
			100	6.9	2100	56.6	2300	61.7	1800	49.1	2700	71.8	3200	85.9	4700	127	6500	175	9400	252
			150	10.3	2200	60.3	2300	62.9	2000	52.4	2900	76.5	3500	92.6	5200	139	6600	178	9800	264
			200	13.8	2400	64	2400	64	2100	55.7	3000	81.1	3700	99.2	5700	152	6700	180	10,000	275
			250	17.2	2400	64	2400	64	2300	61.2	3200	84.9	4300	116	6100	164	6900	184	11,000	292
	15	1.0	20	1.4	600	16.1	830	22.3	1500	41.3	2200	59.5	1600	42.8	2500	66.3	3200	85	4700	126
			30	2.1	930	25	1200	32	1800	47.9	2500	66.7	1900	51.4	3000	81.7	4300	115	6600	176
			50	3.4	1600	42.8	1900	51.4	2300	61.1	3000	81.2	2600	68.7	4200	112	6500	174	10,000	276
			75	5.2	2000	54.9	2300	62	2400	63.8	3300	87.1	3000	80.7	4800	127	7600	204	12,000	310
			100	6.9	2500	67	2700	72.7	2500	66.5	3500	93.1	3500	92.8	5300	142	8700	233	13,000	344
			150	10.3	2600	70.6	2800	74.1	2700	71.6	3800	101	3900	104	5900	159	8800	237	13,000	359
			200	13.8	2800	74.2	2800	75.6	2900	76.6	4100	109	4300	115	6600	177	9000	240	14,000	373
			250	17.2	2800	76	2800	76	2900	78.3	4100	110	4700	126	7200	193	9200	247	14,000	380
13 to 30 / 0.90 to 2.1	20	1.4	30	2.1	710	19	1100	29.1	1800	49	2900	77.2	2000	54.3	3400	90.8	4400	117	7000	188
			40	2.8	970	25.9	1400	37.5	2100	56.1	3200	86.9	2200	57.7	3600	97.8	5500	146	8800	237
			50	3.4	1200	32.9	1700	45.9	2400	63.2	3600	96.6	2300	61.2	3900	105	6500	176	11,000	286
			75	5.2	1700	44.6	2200	59	2600	68.6	3800	103	2900	77	4900	130	8000	215	13,000	338
			100	6.9	2100	56.3	2700	72	2800	74	4000	108	3500	92.8	5800	156	9500	254	15,000	391
			150	10.3	2500	66.5	2900	77.5	3000	80.1	4400	117	4000	107	6300	170	11,000	282	16,000	418
			200	13.8	2900	76.7	3100	83.1	3200	86.3	4700	125	4500	122	6800	184	12,000	309	17,000	446
			250	17.2	3000	80.5	3100	82.6	3500	93.1	4800	129	5000	134	7900	212	12,000	315	17,000	458
	30	2.1	40	2.8	880	23.6	1400	38.6	2700	71	4200	113	2400	63	3500	93.8	6500	174	9000	241
			50	3.4	1300	35.3	1800	48.7	2900	77.7	4500	121	2700	73.2	4100	110	7900	212	11,000	302
			75	5.2	1900	51.8	2500	67.2	3300	89.5	5000	134	3400	90.2	5200	141	10,000	272	15,000	415
			100	6.9	2500	68.2	3200	85.6	3800	101	5500	147	4000	107	6400	171	12,000	333	20,000	527
			150	10.3	3100	83.2	3600	96.2	4100	109	5900	159	4900	132	7700	205	14,000	376	21,000	565
			200	13.8	3700	98.1	4000	107	4400	117	6300	170	5900	157	8900	240	16,000	420	23,000	604
			250	17.2	3900	104	4000	108	4700	125	6600	176	6600	178	10,000	271	16,000	429	23,000	623

1. To obtain capacities for regulators using metal diaphragms, multiply the table values by 0.8.
2. To obtain capacities for regulators with reduced flow orifices, multiply the table values by 0.7.

To determine wide-open flow capacity for relief valve sizing of air at a temperature of 60°F, use the equation for critical pressure drops (absolute outlet pressure equal to one-half or less than one-half the absolute inlet pressure).

$$Q = P_{1(ABS)} C_g$$

where,

Q = Gas flow, SCFH (60°F and 14.7 psia)

P_{1(ABS)} = Absolute inlet pressure, psia (add 14.7 psi to gauge inlet pressure to obtain absolute inlet pressure)

C_g = Wide-open gas sizing coefficient from Table 5

For pressure drops lower than critical (absolute outlet pressure greater than one-half the absolute inlet pressure), use the sizing nomographs in Fisher® Catalog 10, or the Fisher Sizing Program.

To obtain capacities in Nm³/h at 0°C and 1.01325 bar, multiply the capacity determined in SCFH by 0.0268.

Steam Capacities

Capacities in Tables 15, 16, 17, 18 and 19 are in lbs/h of saturated steam. To obtain capacities in kg/h, multiply the capacities given in the table by 0.4535. Capacities have been calculated for stainless steel diaphragms only since steam service exceeds the elastomer diaphragm temperature limits.

To determine wide-open flow capacity for relief valve sizing of steam, use the equation for critical pressure drops (absolute outlet pressure equal to one-half or less than one-half absolute inlet pressure).

$$Q = P_{1(ABS)} C_s$$

where,

Q = Steam flow, lbs/h

P_{1(ABS)} = Absolute inlet pressure, psia (add 14.7 psi to gauge inlet pressure to obtain absolute inlet pressure)

C_s = Wide-open steam sizing coefficient from Table 5

Table 11. Air Capacities⁽¹⁾⁽²⁾ in SCFH / Nm³/h for 1/4 NPT and 1/2 through 1 in. / DN 15 through 25 Types MR95H and MR95HD Regulators with Elastomer Diaphragm

RECOMMENDED OUTLET/ DIFFERENTIAL PRESSURE RANGE, psig/psi / bar	PRESSURE				REGULATOR BODY SIZE, IN. / DN															
	Outlet / Differential Setting		Inlet		1/4 NPT				1/2 / 15				3/4 / 20				1 / 25			
					Droop				Droop				Droop				Droop			
					10%		20%		10%		20%		10%		20%		10%		20%	
	psig	bar	psig	bar	SCFH	Nm ³ /h	SCFH	Nm ³ /h	SCFH	Nm ³ /h	SCFH	Nm ³ /h	SCFH	Nm ³ /h	SCFH	Nm ³ /h	SCFH	Nm ³ /h	SCFH	Nm ³ /h
15 to 30 / 1.0 to 2.1	15	1.0	30	2.1	430	11.5	780	20.9	1000	27.2	1700	44.5	2100	56	3300	88.3	2300	62.8	4100	110
			40	2.8	530	14.2	940	25.3	1200	32.6	1900	51.4	2500	65.9	3900	104	3100	82.3	5300	143
			50	3.4	640	17	1100	29.7	1400	38	2200	58.4	2800	75.8	4500	120	3800	102	6600	176
			75	5.2	850	22.9	1500	40.1	1600	43.7	2400	64.8	3700	99.4	5500	147	5200	138	8300	223
			100	6.9	1100	28.8	1900	50.6	1800	49.3	2700	71.2	4600	123	6500	174	6500	174	10,000	269
			150	10.3	1600	44.1	2200	59.2	2500	68	3300	88.2	5700	154	7300	196	8400	226	12,000	327
	200	13.8	2200	59.4	2500	67.8	3200	86.6	3900	105	6900	185	8200	219	10,000	277	14,000	385		
	250	17.2	2300	61.4	2600	70.8	3700	99.1	4300	115	7200	192	8600	231	12,000	315	16,000	428		
	300	20.7	2400	63.3	2800	73.8	4200	112	4700	126	7400	198	9100	244	13,000	354	18,000	472		
	30	2.1	40	2.8	750	20.1	1400	36.2	1700	45.8	3000	81.5	3500	93.8	6000	161	4000	107	8000	214
	50		3.4	1000	27.4	1600	42.4	2000	53.7	3400	90.3	4100	110	7100	189	5600	149	10,000	269	
	75		5.2	1400	36.9	2200	58.3	2500	66.9	3900	104	5400	144	8500	227	7600	203	13,000	350	
100	6.9		1700	46.5	2800	74.2	3000	80.1	4400	117	6700	179	9900	264	9600	258	16,000	431		
150	10.3		2000	54.8	3200	85.4	3500	94.1	5100	137	6600	176	10,000	273	12,000	329	19,000	496		
200	13.8		2400	63.1	3600	96.5	4000	108	5800	157	6400	173	10,000	281	15,000	401	21,000	561		
250	17.2	2900	76.9	3900	104	4800	129	6400	172	6400	172	11,000	284	15,000	401	21,000	568			
300	20.7	3400	90.7	4100	111	5600	150	7000	186	6400	172	11,000	288	15,000	400	21,000	576			
25 to 75 / 1.7 to 5.2	50	3.4	60	4.1	1000	26.8	2000	53.6	2500	66.2	4500	121	5900	158	9500	255	5500	147	12,000	327
			75	5.2	1400	38.5	2500	68.1	3100	83.6	5200	140	6500	175	11,000	287	8500	228	14,000	385
			100	6.9	1800	48.8	3200	86.2	3800	101	6200	165	8100	218	13,000	340	10,000	272	18,000	488
			150	10.3	2500	66.7	4100	110	4800	128	7300	196	9500	255	15,000	394	14,000	382	22,000	595
			200	13.8	3200	84.6	5000	134	5800	156	8500	227	11,000	292	17,000	447	18,000	493	26,000	702
			250	17.2	3800	102	5300	142	6500	173	8900	238	12,000	310	17,000	465	18,000	471	28,000	740
	300	20.7	4400	119	5600	149	7100	191	9300	250	12,000	329	18,000	482	17,000	448	29,000	777		
	75	5.2	100	6.9	2400	65.4	3900	105	3000	80.6	6700	179	10,000	278	17,000	445	12,000	316	19,000	519
	125		8.6	3000	79.8	4700	127	4100	109	7700	205	12,000	313	18,000	491	15,000	393	24,000	636	
	150		10.3	3500	94.2	5500	149	5200	138	8600	231	13,000	349	20,000	537	18,000	470	28,000	752	
	200		13.8	4600	123	7200	192	7300	196	11,000	283	16,000	420	24,000	630	23,000	624	37,000	985	
	250		17.2	5300	141	7600	205	8300	222	12,000	313	16,000	438	25,000	657	24,000	650	38,000	1030	
300	20.7		5900	159	8100	217	9300	249	13,000	344	17,000	456	26,000	684	25,000	677	40,000	1070		
70 to 150 / 4.8 to 10.3	100	6.9	125	8.6	2200	58.7	3600	96.6	5400	144	8900	239	12,000	323	20,000	525	13,000	343	21,000	573
			150	10.3	2700	73.1	4500	122	6400	172	10,000	277	14,000	381	23,000	610	17,000	459	27,000	736
			175	12.1	3100	83.6	5200	139	7100	191	11,000	298	16,000	438	25,000	684	19,000	512	31,000	838
			200	13.8	3500	94.2	5800	157	7900	211	12,000	320	18,000	495	28,000	758	21,000	564	35,000	939
			250	17.2	4200	112	6700	179	8900	240	13,000	360	20,000	540	30,000	808	25,000	668	40,000	1080
			300	20.7	4800	129	7500	202	10,000	269	15,000	399	22,000	586	32,000	858	29,000	771	45,000	1210
	150	10.3	175	12.1	3400	91	5400	144	8900	238	14,000	371	13,000	357	26,000	709	18,000	481	30,000	793
	200		13.8	4200	114	6500	174	10,000	272	16,000	429	16,000	425	31,000	835	25,000	665	36,000	961	
	225		15.5	4900	132	7400	198	11,000	290	17,000	443	18,000	473	33,000	894	28,000	747	41,000	1110	
	250		17.2	5600	151	8200	221	12,000	309	17,000	457	19,000	521	36,000	954	31,000	829	47,000	1260	
	300		20.7	7000	188	10,000	267	13,000	346	18,000	485	23,000	616	40,000	1070	37,000	994	58,000	1560	

1. To obtain capacities for Type MR95HT (metal diaphragm), multiply the table values by 0.6.
 2. To obtain capacities for regulators with reduced flow orifices, multiply the table values by 0.7.

For pressure drops lower than critical (absolute outlet pressure greater than one-half absolute inlet pressure), use the sizing nomographs in the Fisher® Sizing Program.

Water Capacities

All water capacities in Tables 20, 21, 22, 23 and 24 are in gallons per minute (GPM). Capacities in Tables 20, 21 and 23 are for regulators using only elastomer diaphragms. Depending on regulator size, a multiplier, given in these

tables, must be used to convert to capacities for regulators using metal diaphragms.

To determine flow capacity for liquid relief valve sizing, refer to the Fisher Sizing Program using the C_v coefficients given in Table 5. The K_m values listed in Table 5 can be used to predict choked flow on liquid service.

To convert capacities to m³/h, multiply GPM by 0.2271.

Bulletin 71.1:MR95

Table 12. Air Capacities⁽¹⁾ in SCFH / Nm³/h for 1-1/2 through 2 in. / DN 40 through 50 Types MR95H and MR95HD Regulators with Elastomer or Stainless Steel Diaphragm

RECOMMENDED OUTLET/ DIFFERENTIAL PRESSURE RANGE, psig/psi / bar	PRESSURE				REGULATOR BODY SIZE, IN. / DN														
	Outlet/ Differential Setting		Inlet		1-1/2 / 40						2 / 50								
					Droop						Droop								
					10%		20%		40%		10%		20%		40%				
	psig	bar	psig	bar	SCFH	Nm ³ /h	SCFH	Nm ³ /h	SCFH	Nm ³ /h	SCFH	Nm ³ /h	SCFH	Nm ³ /h	SCFH	Nm ³ /h			
5 to 80 / 0.34 to 5.5	5	0.34	10	0.69	1000	27.5	1500	40.7	2500	68.2	1000	26.9	1400	38.6	2600	70.8			
			20	1.4	1600	41.7	2200	58.4	3700	99.8	1600	42.6	2300	61.7	4000	107			
			30	2.1	2100	56	2800	76.2	4900	131	2200	58.3	3200	84.9	5400	144			
			50	3.4	3200	84.5	4200	112	7300	195	3300	89.7	4900	131	8100	216			
			75	5.2	4100	109	5700	153	9800	264	5000	134	7200	193	15,000	392			
			100	6.9	5000	134	7200	194	12,000	333	6600	177	9500	256	21,000	568			
			150	10.3	5500	146	7900	213	13,000	347	10,000	270	26,000	695	36,000	959			
			200	13.8	5900	159	8600	231	13,000	360	14,000	363	42,000	1130	50,000	1350			
			250	17.2	7500	200	10,000	273	15,000	415	21,000	569	47,000	1250	51,000	1350			
			300	20.7	9000	241	12,000	315	18,000	471	29,000	775	51,000	1360	51,000	1360			
			5 to 80 / 0.34 to 5.5	30	2.1	40	2.8	7900	212	13,000	340	21,000	551	10,000	275	18,000	471	30,000	814
						50	3.4	8100	216	14,000	362	23,000	629	13,000	346	22,000	590	38,000	1010
75	5.2	14,000				372	22,000	585	37,000	987	19,000	516	43,000	1150	58,000	1560			
100	6.9	20,000				527	30,000	807	50,000	1340	26,000	687	64,000	1710	79,000	2110			
150	10.3	21,000				568	33,000	872	52,000	1380	57,000	1540	86,000	2300	93,000	2500			
200	13.8	23,000				610	35,000	937	53,000	1420	89,000	2390	110,000	2890	110,000	2890			
250	17.2	29,000				772	41,000	1100	57,000	1530	100,000	2700	110,000	2980	110,000	2980			
300	20.7	35,000				934	47,000	1260	61,000	1640	110,000	3010	110,000	3060	110,000	3060			
5 to 80 / 0.34 to 5.5	50	3.4				60	4.1	13,000	349	27,000	724	48,000	1290	14,000	383	32,000	869	50,000	1340
						75	5.2	19,000	516	33,000	873	52,000	1400	21,000	570	42,000	1120	55,000	1490
						100	6.9	26,000	697	41,000	1100	65,000	1750	34,000	925	67,000	1810	76,000	2030
						150	10.3	29,000	779	47,000	1250	72,000	1920	77,000	2050	110,000	2820	110,000	2960
			200	13.8	32,000	860	53,000	1410	78,000	2090	120,000	3180	140,000	3840	150,000	3900			
			250	17.2	42,000	1110	60,000	1620	87,000	2330	140,000	3700	150,000	4100	150,000	4120			
			300	20.7	51,000	1370	68,000	1820	96,000	2570	160,000	4220	160,000	4350	160,000	4350			
			5 to 80 / 0.34 to 5.5	75	5.2	100	6.9	28,000	753	48,000	1280	68,000	1830	33,000	875	62,000	1650	71,000	1910
						125	8.6	35,000	939	59,000	1590	82,000	2190	55,000	1480	82,000	2190	90,000	2410
						150	10.3	42,000	1120	71,000	1900	95,000	2560	78,000	2090	100,000	2730	110,000	2920
						200	13.8	56,000	1490	94,000	2530	120,000	3290	120,000	3300	140,000	3800	150,000	3930
						250	17.2	62,000	1660	97,000	2600	130,000	3560	170,000	4440	180,000	4750	180,000	4810
300	20.7	68,000				1830	100,000	2670	140,000	3840	210,000	5580	210,000	5690	210,000	5690			
60 to 120 / 4.1 to 8.3	100	6.9				125	8.6	33,000	881	60,000	1600	81,000	2160	38,000	1020	70,000	1880	86,000	2310
						150	10.3	37,000	987	65,000	1740	94,000	2520	60,000	1620	90,000	2420	110,000	2830
						175	12.1	41,000	1090	70,000	1880	110,000	2890	83,000	2230	110,000	2960	120,000	3340
						225	15.5	49,000	1300	81,000	2170	130,000	3610	130,000	3440	150,000	4050	160,000	4360
						250	17.2	48,000	1290	84,000	2260	140,000	3730	150,000	3920	170,000	4580	180,000	4820
						300	20.7	47,000	1270	91,000	2440	150,000	3980	180,000	4900	210,000	5650	210,000	5750
			100 to 140 / 6.9 to 9.7	125	8.6	150	10.3	40,000	1070	69,000	1840	94,000	2520	38,000	1020	76,000	2030	100,000	2710
						175	12.1	46,000	1240	83,000	2220	110,000	3020	44,000	1190	100,000	2670	120,000	3260
						200	13.8	53,000	1410	97,000	2600	130,000	3520	50,000	1350	120,000	3310	140,000	3800
						225	15.5	63,000	1700	110,000	2960	150,000	3910	81,000	2170	140,000	3870	160,000	4310
						250	17.2	74,000	1990	120,000	3310	160,000	4310	110,000	2990	160,000	4420	180,000	4830
						300	20.7	96,000	2560	150,000	4020	190,000	5110	170,000	4640	210,000	5530	220,000	5860
120 to 150 / 8.3 to 10.3	150	10.3				175	12.1	38,000	1030	70,000	1870	110,000	2980	38,000	1020	76,000	2040	110,000	3080
						200	13.8	46,000	1240	80,000	2150	130,000	3450	47,000	1270	93,000	2490	140,000	3650
						225	15.5	51,000	1360	87,000	2330	140,000	3770	54,000	1450	120,000	3160	160,000	4190
						250	17.2	55,000	1480	94,000	2520	150,000	4080	61,000	1630	140,000	3840	180,000	4730
						300	20.7	64,000	1710	110,000	2890	180,000	4710	74,000	1990	190,000	5190	220,000	5810

1. To obtain capacities for regulators with reduced flow orifices, multiply the table values by 0.7.

Table 13. Air Capacities⁽¹⁾⁽²⁾ in SCFH / Nm³/h for 1/4 NPT and 1/2 through 1 in. / DN 15 through 25 Type MR95HP (Elastomer Diaphragm) Regulator

RECOMMENDED OUTLET/ DIFFERENTIAL PRESSURE RANGE, psig/psi / bar	PRESSURE				REGULATOR BODY SIZE, IN. / DN																		
	Outlet/ Differential Setting		Inlet		1/4 NPT				1/2 / 15				3/4 / 20				1 / 25						
					Droop		Droop		Droop		Droop												
					10%	20%	10%	20%	10%	20%	10%	20%	10%	20%	10%	20%							
	psig	bar	psig	bar	SCFH	Nm ³ /h	SCFH	Nm ³ /h	SCFH	Nm ³ /h	SCFH	Nm ³ /h	SCFH	Nm ³ /h	SCFH	Nm ³ /h	SCFH	Nm ³ /h					
15 to 100 / 1.0 to 6.9	15	1.0	30	2.1	200	5.36	300	8.04	350	9.47	410	10.9	1100	29.6	2500	67.3	2000	54.1	3600	96.5			
			40	2.8	210	5.63	330	8.71	610	16.4	790	21.1	1500	39.3	2900	78	2200	59	3900	104			
			50	3.4	220	5.9	350	9.38	810	21.8	1100	29.1	1700	46.9	3200	86.3	2400	64	4100	111			
			75	5.2	230	6.17	400	10.7	1200	31.5	1600	43.6	2300	60.5	3800	101	2900	76.4	4800	129			
			100	6.9	250	6.62	450	11.9	1200	32	1900	50.5	2800	74.4	4300	115	3300	88.9	5500	147			
			150	10.3	370	10	610	16.2	1800	47.9	2600	69.3	3000	81	4700	125	4200	114	6900	184			
			200	13.8	500	13.5	770	20.5	2400	63.9	3300	88.2	3300	87.6	5000	135	5200	139	8200	220			
			250	17.2	510	13.7	830	22.3	2400	64.3	3300	87.8	3700	100	5400	146	5500	148	9100	245			
			300	20.7	520	13.9	900	24.1	2400	64.6	3300	87.5	4200	113	5800	156	5900	157	10,000	269			
			400	27.6	640	17.2	950	25.5	2700	71.1	3600	96.8	4400	117	6100	164	6700	179	11,000	298			
			500	34.5	780	20.8	1000	27.8	2800	75.1	4100	110	4600	124	6400	172	7200	194	12,000	323			
			600	41.4	910	24.4	1100	30.1	2900	79	4600	123	4900	131	6700	179	7700	205	13,000	343			
	1000	69.0	910	24.4	1100	30.1	3500	93.3	5000	135	5500	148	7400	198	8900	239	15,000	400					
	50	3.4	60	4.1	880	23.6	1500	40.4	3000	80.4	5100	137	6500	174	10,000	268	6000	161	11,000	295			
			75	5.2	920	24.7	1600	41.8	3200	85.5	5300	143	6800	182	10,000	276	6700	180	12,000	317			
			100	6.9	1000	26.9	1600	42.5	3500	94	5700	154	7300	195	11,000	290	7900	211	13,000	354			
			150	10.3	1100	30.5	1800	48.8	4300	115	6600	178	8200	221	12,000	328	10,000	277	17,000	450			
			200	13.8	1300	34	2100	55	5100	136	7500	201	9200	246	14,000	367	13,000	343	20,000	547			
			250	17.2	1400	38.2	2200	57.7	5700	152	8200	221	10,000	268	15,000	391	15,000	393	23,000	607			
			300	20.7	1600	42.4	2300	60.3	6200	167	9000	241	11,000	289	16,000	416	17,000	444	25,000	667			
			400	27.6	1700	46.3	2400	64.7	7000	188	9300	250	9300	248	14,000	379	19,000	510	29,000	778			
			500	34.5	1700	46.8	2500	65.7	7200	193	9500	254	10,000	272	15,000	405	21,000	564	31,000	835			
			600	41.4	1800	47.4	2500	66.7	7400	199	9600	258	11,000	296	16,000	430	23,000	617	33,000	893			
			1000	69.0	1800	48.3	2500	67	7300	195	10,000	273	13,000	353	18,000	478	28,000	741	38,000	1030			
			100	6.9	125	8.6	2000	54.4	3100	84.2	6600	176	10,000	277	12,000	314	19,000	499	13,000	361	22,000	583	
	150	10.3			2100	57.3	3300	89.1	7200	192	11,000	303	13,000	357	21,000	556	16,000	430	26,000	708			
	175	12.1			2200	60.3	3500	94	7800	208	12,000	328	15,000	399	23,000	613	19,000	499	31,000	834			
	200	13.8			2400	63.2	3700	99	8400	224	13,000	354	16,000	442	25,000	671	21,000	569	36,000	959			
	250	17.2			2600	69.1	3900	105	9800	262	15,000	396	19,000	497	27,000	724	25,000	670	40,000	1090			
	300	20.7			2800	75.1	4100	111	11,000	300	16,000	438	21,000	553	29,000	776	29,000	771	45,000	1210			
	400	27.6			3100	81.8	4300	116	12,000	312	18,000	480	16,000	439	25,000	673	33,000	896	50,000	1350			
	500	34.5			3100	83.6	4400	119	12,000	323	17,000	468	18,000	479	27,000	716	36,000	970	54,000	1450			
	600	41.4			3200	85.5	4500	122	12,000	333	17,000	456	19,000	518	28,000	759	39,000	1040	57,000	1540			
	1000	69.0			3200	85.8	4500	121	14,000	381	19,000	514	21,000	557	31,000	820	46,000	1230	66,000	1770			
	80 to 300 / 5.5 to 20.7	125			8.6	150	10.3	1400	37.1	2300	60.6	4500	119	7600	205	9600	257	16,000	424	9700	261	17,000	447
						175	12.1	1500	39.9	2400	64.9	5100	136	8400	226	11,000	287	17,000	468	11,000	305	19,000	507
200			13.8	1600		42.7	2600	69.3	5700	153	9200	247	12,000	317	19,000	513	13,000	348	21,000	568			
225			15.5	1700		45.2	2700	73.3	6000	162	9800	263	13,000	340	20,000	550	14,000	380	23,000	624			
250			17.2	1800		47.7	2900	77.3	6400	171	10,000	279	14,000	363	22,000	587	15,000	411	25,000	679			
300			20.7	2000		52.8	3200	85.4	7100	190	12,000	311	15,000	410	25,000	661	18,000	474	29,000	791			
400			27.6	2200		60	3500	93.1	8900	240	14,000	387	17,000	454	27,000	713	22,000	592	36,000	966			
500			34.5	2500		65.8	3900	104	10,000	270	16,000	427	19,000	499	29,000	765	26,000	700	41,000	1110			
600			41.4	2700		71.5	4300	114	11,000	301	17,000	467	20,000	543	30,000	817	30,000	807	46,000	1240			
1000			69.0	2000		53	4000	108	15,000	395	21,000	553	27,000	722	38,000	1020	40,000	1070	65,000	1750			
200			13.8	225		15.5	2300	62.3	4000	107	8000	216	14,000	362	16,000	435	27,000	714	18,000	479	31,000	830	
				250		17.2	2600	68.4	4200	113	9000	242	15,000	396	18,000	474	30,000	796	20,000	528	34,000	912	
		300		20.7	3000	80.6	4700	127	11,000	293	17,000	463	21,000	553	36,000	958	23,000	628	40,000	1080			
		350		24.1	3200	85.1	5100	136	12,000	330	20,000	523	24,000	637	42,000	1120	27,000	723	47,000	1250			
		400		27.6	3300	89.5	5400	144	14,000	368	22,000	583	27,000	721	48,000	1280	31,000	818	53,000	1430			
		450		31.0	3500	93.9	5600	150	15,000	391	23,000	619	27,000	736	47,000	1260	34,000	909	57,000	1540			
		500		34.5	3700	98.3	5800	156	15,000	414	24,000	655	28,000	752	46,000	1240	37,000	1000	61,000	1640			
		600		41.4	4000	107	6200	167	17,000	461	27,000	727	29,000	782	45,000	1210	44,000	1180	69,000	1860			
		1000		69.0	4500	120	6900	186	22,000	585	31,000	834	41,000	1090	59,000	1590	56,000	1510	87,000	2340			
		300		20.7	350	24.1	4000	106	6800	181	14,000	386	24,000	646	25,000	677	40,000	1080	32,000	850	56,000	1500	
					400	27.6	4400	118	7200	194	17,000	444	28,000	761	26,000	704	41,000	1100	37,000	987	65,000	1740	
					450	31.0	4700	126	7600	205	18,000	484	30,000	814	31,000	826	48,000	1290	42,000	1130	73,000	1950	
500			34.5		5000	135	8000	215	20,000	524	32,000	866	35,000	949	55,000	1480	47,000	1270	81,000	2160			
550			37.9		5300	143	8400	225	21,000	564	34,000	919	40,000	1070	62,000	1680	53,000	1410	89,000	2380			
600			41.4		5600	151	8800	236	23,000	604	36,000	971	44,000	1190	70,000	1870	58,000	1560	96,000	2590			
1000			69.0		6300	169	10,000	268	30,000	812	46,000	1230	57,000	1530	85,000	2290	80,000	2160	100,000	2750			
80 to 400 / 5.5 to 27.6 Type MR95HP Only			400		27.6	500	34.5	5700	152	9800	263	21,000	559	35,000	944	38,000	1010	64,000	1710	49,000	1320	86,000	2310
						600	41.4	6500	174	11,000	292	26,000	693	42,000	1130	45,000	1210	79,000	2120	59,000	1590	110,000	2860
						1000	69.0	9000	241	13,000	355	35,000	934	54,000	1450	61,000	1640	100,000	2700	80,000	2150	140,000	3650

1. To obtain capacities for Type MR95HT (metal diaphragm), multiply the table values by 0.6. Capacity data for 1000 psig / 69.0 bar inlet is not applicable for Type MR95HT (Type MR95HT max. inlet = 600 psig / 41.4 bar).
 2. To obtain capacities for regulators with reduced flow orifices, multiply the table values by 0.7.

Bulletin 71.1:MR95

Table 14. Air Capacities⁽¹⁾ in SCFH / Nm³/h for 1-1/2 through 2 in. / DN 40 through 50 Type MR95HP (Elastomer Diaphragm) Regulator

RECOMMENDED OUTLET/ DIFFERENTIAL PRESSURE RANGE, psig/psi / bar	PRESSURE				REGULATOR BODY SIZE, IN. / DN														
	Outlet/ Differential Setting		Inlet		1-1/2 / 40						2 / 50								
					Droop				Droop										
					10%		20%		40%		10%		20%		40%				
				SCFH	Nm ³ /h	SCFH	Nm ³ /h	SCFH	Nm ³ /h	SCFH	Nm ³ /h	SCFH	Nm ³ /h	SCFH	Nm ³ /h				
15 to 100 / 1.0 to 6.9	15	1.0	30	2.1	4000	108	6000	160	11,000	286	4000	107	6700	179	13,000	338			
			40	2.8	5000	134	7600	205	13,000	346	5700	152	9300	250	18,000	484			
			50	3.4	6000	161	9300	249	15,000	405	7400	198	12,000	322	23,000	629			
			75	5.2	8400	226	13,000	343	21,000	566	11,000	301	26,000	709	38,000	1020			
			100	6.9	11,000	292	16,000	437	27,000	727	15,000	404	41,000	1100	53,000	1420			
			150	10.3	12,000	321	20,000	524	31,000	820	43,000	1150	60,000	1620	66,000	1780			
			200	13.8	13,000	351	23,000	611	34,000	913	71,000	1890	80,000	2150	80,000	2150			
			250	17.2	14,000	379	22,000	596	34,000	924	45,000	1210	81,000	2180	81,000	2180			
			300	20.7	15,000	407	22,000	582	35,000	934	35,000	937	82,000	2210	82,000	2210			
			400	27.6	11,000	306	17,000	454	35,000	936	35,000	937	82,000	2210	82,000	2210			
			500	34.5	7700	205	12,000	327	35,000	938	35,000	937	82,000	2210	82,000	2210			
			600	41.4	11,000	282	14,000	363	35,000	938	35,000	937	82,000	2210	82,000	2210			
	1000	69.0	12,000	313	17,000	461	35,000	938	35,000	937	82,000	2210	82,000	2210					
	50	3.4	60	4.1	11,000	306	21,000	553	38,000	1020	13,000	361	24,000	642	44,000	1170			
			75	5.2	14,000	387	27,000	712	48,000	1280	19,000	496	39,000	1050	57,000	1540			
			100	6.9	19,000	521	36,000	978	63,000	1700	27,000	722	64,000	1720	80,000	2140			
			150	10.3	27,000	712	51,000	1370	80,000	2140	78,000	2100	100,000	2800	110,000	3080			
			200	13.8	34,000	902	66,000	1770	97,000	2590	130,000	3480	140,000	3880	150,000	4020			
			250	17.2	42,000	1120	70,000	1890	97,000	2600	92,000	2450	160,000	4340	160,000	4410			
			300	20.7	50,000	1340	75,000	2010	97,000	2600	92,000	2450	180,000	4800	180,000	4800			
			400	27.6	46,000	1240	70,000	1890	97,000	2600	92,000	2450	180,000	4800	180,000	4800			
			500	34.5	42,000	1140	66,000	1770	97,000	2600	92,000	2450	180,000	4800	180,000	4800			
			600	41.4	27,000	730	54,000	1450	98,000	2630	92,000	2450	180,000	4800	180,000	4800			
			1000	69.0	28,000	762	73,000	1960	100,000	2690	92,000	2450	180,000	4800	180,000	4800			
			100	6.9	125	8.6	29,000	791	56,000	1510	86,000	2290	40,000	1080	75,000	2010	89,000	2390	
	150	10.3			38,000	1010	75,000	2000	100,000	2760	72,000	1930	98,000	2640	110,000	2950			
	200	13.8			54,000	1440	110,000	2990	140,000	3700	140,000	3620	150,000	3890	150,000	4080			
	250	17.2			59,000	1580	110,000	3010	150,000	4100	180,000	4760	180,000	4950	190,000	5080			
	300	20.7			65,000	1730	110,000	3030	170,000	4500	220,000	5910	220,000	6020	230,000	6080			
	400	27.6			68,000	1810	120,000	3190	170,000	4610	230,000	6030	230,000	6170	240,000	6430			
	500	34.5			71,000	1890	120,000	3350	180,000	4720	230,000	6030	230,000	6170	240,000	6430			
	600	41.4			81,000	2160	130,000	3580	180,000	4710	230,000	6030	230,000	6170	240,000	6430			
	1000	69.0			100,000	2680	140,000	3840	180,000	4780	230,000	6030	230,000	6170	250,000	6700			
	60 to 260 / 4.1 to 17.9	125			8.6	150	10.3	23,000	616	37,000	1000	71,000	1900	26,000	697	46,000	1240	91,000	2440
						175	12.1	27,000	724	44,000	1190	83,000	2220	30,000	817	57,000	1520	110,000	2970
						200	13.8	31,000	831	51,000	1380	95,000	2550	35,000	938	67,000	1800	130,000	3510
225			15.5	34,000		920	56,000	1490	100,000	2750	41,000	1110	87,000	2340	150,000	4020			
250			17.2	38,000		1010	60,000	1600	110,000	2960	48,000	1290	110,000	2890	170,000	4540			
300			20.7	44,000		1190	68,000	1830	130,000	3360	61,000	1640	150,000	3980	210,000	5570			
400			27.6	54,000		1440	89,000	2370	140,000	3870	73,000	1940	180,000	4830	230,000	6190			
500			34.5	63,000		1680	110,000	2920	160,000	4380	84,000	2250	210,000	5710	260,000	7010			
600			41.4	75,000		2010	120,000	3290	180,000	4750	93,000	2490	240,000	6430	280,000	7600			
1000			69.0	77,000		2060	120,000	3290	190,000	5100	94,000	2520	240,000	6430	300,000	8040			
200			13.8	225		15.5	39,000	1040	68,000	1810	130,000	3380	43,000	1150	85,000	2270	150,000	4010	
				250		17.2	45,000	1200	76,000	2050	140,000	3770	49,000	1320	100,000	2810	170,000	4600	
		300		20.7	57,000	1520	94,000	2520	170,000	4570	62,000	1650	150,000	3900	220,000	5770			
		350		24.1	64,000	1710	110,000	2830	190,000	5100	72,000	1920	180,000	4770	250,000	6630			
		400		27.6	71,000	1910	120,000	3140	210,000	5630	80,000	2150	210,000	5530	270,000	7320			
		450		31.0	79,000	2110	130,000	3450	230,000	6160	88,000	2360	230,000	6200	300,000	8010			
		500		34.5	86,000	2300	140,000	3770	250,000	6690	95,000	2540	250,000	6800	320,000	8690			
		600		41.4	100,000	2710	170,000	4480	280,000	7390	110,000	2860	290,000	7850	360,000	9610			
		1000		69.0	130,000	3450	230,000	6090	290,000	7690	140,000	3760	350,000	9380	370,000	10,000			
		250		17.2	275	19.0	53,000	1430	94,000	2520	160,000	4400	51,000	1370	110,000	2820	180,000	4870	
					300	20.7	63,000	1680	110,000	2840	190,000	5000	63,000	1700	130,000	3550	200,000	5490	
					350	24.1	73,000	1960	120,000	3280	210,000	5670	81,000	2160	130,000	3610	230,000	6240	
400			27.6		84,000	2250	140,000	3720	240,000	6340	92,000	2470	150,000	4100	260,000	6970			
450			31.0		95,000	2540	160,000	4160	260,000	7000	100,000	2790	170,000	4580	290,000	7700			
500			34.5		110,000	2820	170,000	4600	290,000	7670	120,000	3100	190,000	5060	310,000	8440			
550			37.9		110,000	2950	180,000	4870	310,000	8200	120,000	3240	200,000	5360	340,000	9030			
600			41.4		110,000	3070	190,000	5150	330,000	8740	130,000	3380	210,000	5660	360,000	9610			
1000			69.0		160,000	4400	240,000	6320	390,000	10,500	180,000	4840	260,000	6950	430,000	11,500			
60 to 300 / 4.1 to 20.7 Type MR95HP Only			300		20.7	350	24.1	75,000	2010	140,000	3750	230,000	6030	80,000	2140	200,000	5360	250,000	6640
						400	27.6	89,000	2380	150,000	4040	260,000	6860	98,000	2620	170,000	4450	280,000	7540
						450	31.0	100,000	2690	170,000	4680	280,000	7640	110,000	2960	190,000	5150	310,000	8400
		500		34.5		110,000	2990	200,000	5320	310,000	8420	120,000	3290	220,000	5850	350,000	9260		
		550		37.9		120,000	3180	210,000	5510	330,000	8840	130,000	3490	230,000	6060	360,000	9730		
		600		41.4		130,000	3360	210,000	5690	350,000	9260	140,000	3700	230,000	6260	380,000	10,200		
		1000		69.0		190,000	5090	330,000	8770	460,000	12,400	210,000	5600	360,000	9650	510,000	13,600		

1. To obtain capacities for regulators with reduced flow orifices, multiply the table values by 0.7.
 - Denotes capacities limited by boost.

Table 15. Steam Capacities⁽¹⁾ for 1/4 NPT and 1/2 through 1 in. / DN 15 through 25 Types MR95L and MR95LD Regulators with Metal Diaphragm

RECOMMENDED OUTLET/ DIFFERENTIAL PRESSURE RANGE, psig/psi / bar	PRESSURE				REGULATOR BODY SIZE, IN. / DN															
	Outlet/ Differential Setting		Inlet		1/4 NPT				1/2 / 15				3/4 / 20				1 / 25			
					Droop		Droop		Droop		Droop									
					10%	20%	10%	20%	10%	20%	10%	20%	10%	20%	10%	20%				
	psig	bar	psig	bar	lb/h	kg/h	lb/h	kg/h	lb/h	kg/h	lb/h	kg/h	lb/h	kg/h	lb/h	kg/h	lb/h	kg/h		
2 to 6 / 0.14 to 0.41	5	0.34	20	1.4	26	11.8	32	14.5	35	16.1	53	24.1	43	19.3	78	35.4	99	45.1	160	74.1
			30	2.1	33	15	38	17.4	39	17.5	56	25.4	49	22.4	88	39.9	120	52.7	180	83
			50	3.4	48	21.9	52	23.5	41	18.9	59	26.7	63	28.4	110	50.5	150	66.3	220	99.4
			75	5.2	55	25	58	26.6	45	20.3	62	28.2	79	36.1	120	54.9	150	69	230	105
			100	6.9	62	28.1	65	29.7	45	20.3	62	28.2	93	42.3	130	61	160	72	240	111
			150	10.3	62	28.2	69	31.3	52	23.5	69	31.3	83	37.5	140	62.6	160	72	250	116
			200	13.8	62	28.2	69	31.3	55	25	72	32.8	72	32.9	140	62.6	160	72	260	119
			250	17.2	62	28.2	69	31.3	52	23.5	72	32.9	69	31.3	130	59.5	170	76.7	270	124
5 to 15 / 0.34 to 1.0	10	0.69	20	1.4	24	10.8	33	15	43	19.5	68	30.8	61	27.6	96	43.8	110	48.8	170	76.3
			30	2.1	33	15.2	42	19.1	46	20.9	71	32	67	30.6	110	49.8	130	57.9	210	93.2
			50	3.4	52	23.6	59	26.7	59	26.9	83	37.9	87	39.7	130	60.3	170	77.9	280	127
			75	5.2	62	28.1	69	31.3	59	26.7	86	39.2	97	44.1	150	67.7	200	89.8	300	137
			100	6.9	72	32.8	79	36	62	28.2	93	42.2	110	50.2	160	73.7	220	102	320	147
			150	10.3	76	34.4	79	36	69	31.3	100	45.4	120	54.8	180	81.3	230	103	340	153
			200	13.8	83	37.5	83	37.5	72	32.8	100	46.9	130	57.9	200	89.2	230	105	340	156
			250	17.2	83	37.5	83	37.5	79	36	110	50.1	150	67.3	210	95.4	240	108	380	172
	15	1.0	20	1.4	22	9.81	30	13.5	54	24.6	79	35.9	58	26.2	90	40.9	120	52.4	170	76.8
			30	2.1	33	15	42	19.3	64	29.1	89	40.3	68	30.8	110	48.5	150	69.7	230	107
			50	3.4	56	25.3	66	30	81	36.6	100	47.7	91	41.6	150	67	230	104	350	160
			75	5.2	69	31.3	79	36	83	37.8	110	51.9	100	47.5	170	75.8	260	120	420	190
			100	6.9	86	39.1	93	42.2	86	39.2	120	54.8	120	55	180	83.3	300	137	450	204
			150	10.3	89	40.7	96	43.8	93	42.2	130	59.4	130	61.1	200	92.4	300	138	450	203
			200	13.8	96	43.8	96	43.8	100	45.4	140	64.1	150	67.3	230	103	310	141	480	219
			250	17.2	96	43.8	96	43.8	100	45.4	140	64.1	160	73.5	250	113	320	144	480	219
13 to 30 / 0.90 to 2.1	20	1.4	30	2.1	25	11.5	39	17.8	65	29.3	100	47.1	72	32.6	120	55.3	160	71.8	250	114
			40	2.8	34	15.6	49	22.4	75	33.9	110	51.5	78	35.6	130	58.1	200	89	310	142
			50	3.4	42	19.1	59	27	85	38.5	130	57.5	81	37	140	62.5	230	104	390	176
			75	5.2	59	26.7	76	34.5	91	41.2	130	60	100	46.1	170	77.7	280	127	450	206
			100	6.9	72	32.8	93	42.2	97	44	140	62.7	120	55.2	200	91.4	330	150	520	236
			150	10.3	86	39.1	100	45.4	100	46.9	150	68.8	140	62.7	220	98.7	380	172	550	251
			200	13.8	100	45.4	110	48.5	110	50.1	160	73.5	150	70.4	230	106	410	188	590	266
			250	17.2	100	46.9	110	48.5	120	54.8	170	75.1	170	78.2	270	124	410	188	590	266
	30	2.1	40	2.76	32	14.3	50	22.7	97	44.1	150	68.3	86	39.2	130	57	230	106	320	147
			50	3.4	46	21	64	29	100	47	160	72.6	96	43.8	150	66.3	280	128	390	178
			75	5.2	66	30.2	87	39.6	120	52.7	180	79.6	120	54.5	180	83.1	350	160	530	240
			100	6.9	86	39.3	110	50.2	130	60.1	190	86.8	140	63.6	220	102	420	191	700	317
			150	10.3	110	48.5	120	56.3	140	64.3	200	92.4	170	77.1	270	121	480	220	730	330
			200	13.8	130	57.9	140	62.6	150	68.8	220	98.5	200	92.5	310	139	550	251	790	360
			250	17.2	130	61	140	62.6	160	73.5	230	103	230	103	340	157	550	250	790	360

1. Capacities are based in lbs/h / kg/h of saturated steam.

Bulletin 71.1:MR95

Table 16. Steam Capacities⁽¹⁾ for 1/4 NPT and 1/2 through 1 in. / DN 15 through 25 Types MR95H and MR95HD Regulators with Metal Diaphragm

RECOMMENDED OUTLET/ DIFFERENTIAL PRESSURE RANGE, psig/psi / bar	PRESSURE				REGULATOR BODY SIZE, IN. / DN															
	Outlet/ Differential Setting		Inlet		1/4 NPT				1/2 / 15				3/4 / 20				1 / 25			
					Droop				Droop				Droop				Droop			
					10%		20%		10%		20%		10%		20%		10%		20%	
	psig	bar	psig	bar	lb/h	kg/h	lb/h	kg/h	lb/h	kg/h	lb/h	kg/h	lb/h	kg/h	lb/h	kg/h	lb/h	kg/h	lb/h	kg/h
15 to 30 / 1.0 to 2.1	15	1.0	30	2.1	11	5.2	21	9.41	27	12.1	45	20.6	56	25.5	88	40	62	28	110	49.7
			40	2.8	14	6.34	25	11.2	32	14.4	50	22.8	66	30.2	100	46.9	82	37.4	140	63.8
			50	3.4	17	7.6	29	13	37	16.7	58	26.2	74	33.6	120	53.9	100	45.6	170	79
			75	5.2	22	9.98	39	17.6	42	18.9	62	28.3	97	43.9	140	65.2	140	61.7	220	98.4
			100	6.9	28	12.9	49	22.3	47	21.1	70	31.7	120	54.3	170	76.6	170	76.7	260	118
			150	10.3	41	18.8	57	25.8	65	29.3	85	38.7	150	66.9	190	85.7	220	98.6	310	141
			200	13.8	57	25.8	65	29.3	83	37.5	100	45.8	180	81	210	96.2	260	117	360	164
	250	17.2	59	27	67	30.5	96	43.4	110	50.5	190	84.5	220	101	310	141	410	188		
	300	20.7	62	28.2	72	32.8	110	49.3	120	55.1	190	86.8	230	107	340	153	460	211		
	30	2.1	40	2.8	20	9.17	37	17	46	20.8	81	36.6	94	42.9	160	73.3	110	49	220	97.7
			50	3.4	27	12.1	42	19.3	53	24.3	91	41.2	110	49.9	190	86.2	150	68.2	270	121
			75	5.2	37	16.7	57	26.1	66	30	100	46.6	140	64.9	220	102	200	91.4	340	156
			100	6.9	44	20	72	32.9	78	35.6	110	52.1	180	79.9	260	118	250	114	420	190
			150	10.3	52	23.5	83	37.5	91	41.1	130	59.9	170	77.9	260	118	310	142	490	224
200			13.8	62	28.2	93	42.2	100	46.9	150	68	170	75.2	260	117	390	176	540	247	
250			17.2	75	34	100	45.8	120	56.3	170	75.1	170	75.1	280	129	390	176	540	247	
300	20.7	88	39.9	110	48.1	140	65.7	180	82.1	170	75.1	280	129	390	176	540	246			
25 to 75 / 1.7 to 5.2	50	3.4	60	4.1	27	12.3	54	24.4	68	30.7	120	55	160	72.5	260	116	150	67.6	320	147
			75	5.2	37	17	66	30.2	83	37.7	140	63	170	79.2	290	134	230	104	370	170
			100	6.9	47	21.6	84	38.2	100	45.7	160	74.4	220	97.8	340	156	270	121	480	217
			150	10.3	65	29.5	110	48.2	130	57	190	86.4	250	113	390	178	370	167	580	262
			200	13.8	83	37.5	130	58.7	150	68.3	220	99.9	290	130	440	201	470	213	680	307
			250	17.2	98	44.6	140	62.2	170	76.3	230	104	310	141	440	200	470	212	720	329
			300	20.7	110	51.6	140	65.7	180	83.3	240	109	310	141	470	211	440	200	750	341
	75	5.2	100	6.9	64	29.2	99	45	81	36.6	180	81.5	270	122	460	207	320	147	510	231
			125	8.6	80	36.2	120	56.4	110	49.6	200	92.8	320	146	480	218	400	182	640	290
			150	10.3	92	41.9	140	65.5	140	62.5	230	103	340	157	530	240	480	217	740	336
			200	13.8	120	54.3	190	84.8	190	86.8	290	130	420	191	630	286	600	275	970	441
			250	17.2	140	62.2	200	89.2	220	98	310	141	420	190	650	296	630	285	990	450
			300	20.7	150	69.2	210	95	240	109	340	153	440	201	670	307	650	295	1000	472
			70 to 150 / 4.8 to 10.3	100	6.9	125	8.6	59	26.9	96	43.7	150	66.1	240	108	320	147	540	244	350
150	10.3	72				32.7	120	54.2	170	77.7	270	121	370	170	610	279	460	207	720	327
175	12.1	82				37.3	140	62.2	190	85.7	290	132	430	194	660	301	510	230	820	374
200	13.8	92				41.8	150	69	210	94.9	320	144	480	217	740	336	560	253	920	420
250	17.2	110				49.7	170	79	230	106	340	154	530	239	790	358	660	299	1000	477
300	20.7	120				56.4	190	88	260	118	390	177	580	262	840	380	760	345	1200	534
150	10.3	175				12.1	92	41.7	140	65.8	240	109	380	171	350	160	700	318	490	221
		200		13.8	110	51.1	170	78.7	270	122	430	194	430	195	830	377	670	305	960	438
		225		15.5	130	59.3	200	89	290	134	450	205	480	219	880	400	750	341	1100	497
		250		17.2	150	67.4	220	98.2	320	145	450	205	510	230	960	434	830	376	1200	567
		300		20.7	180	83.5	260	119	340	156	470	215	610	277	1100	480	980	445	1500	695

1. Capacities are based in lbs/h / kg/h of saturated steam.

Table 17. Steam Capacities⁽¹⁾ for 1-1/2 through 2 in. / DN 40 through 50 Types MR95H and MR95HD Regulators with Metal Diaphragm

RECOMMENDED OUTLET/ DIFFERENTIAL PRESSURE RANGE, psig/psi / bar	PRESSURE				REGULATOR BODY SIZE, IN. / DN													
	Outlet/ Differential Setting		Inlet		1-1/2 / 40						2 / 50							
					Droop						Droop							
					10%		20%		40%		10%		20%		40%			
psig	bar	psig	bar	lb/h	kg/h	lb/h	kg/h	lb/h	kg/h	lb/h	kg/h	lb/h	kg/h	lb/h	kg/h			
5 to 80 / 0.34 to 5.5	5	0.34	10	0.69	45	20.4	67	30.6	110	50.9	45	20.4	63	28.6	120	52.9		
			20	1.4	71	32.2	97	44.3	160	74.3	71	32.2	100	46.3	180	80.3		
			30	2.1	92	41.9	120	55.8	210	97.6	97	43.9	140	63.8	240	108		
			50	3.4	140	63.2	180	82.9	320	144	140	65.2	210	96.7	350	160		
			75	5.2	180	80.4	250	112	420	192	220	98	310	141	650	294		
			100	6.9	210	97.6	310	140	510	234	280	129	410	185	900	410		
			150	10.3	240	107	340	154	560	253	430	194	1100	505	1500	700		
			200	13.8	250	115	370	167	560	252	600	272	1800	816	2100	971		
			250	17.2	320	146	430	194	640	291	900	408	2000	912	2200	990		
			300	20.7	380	175	510	233	770	349	1200	563	2200	990	2200	990		
	30	2.1	40	2.8	350	161	580	265	930	424	450	204	810	366	1300	606		
			50	3.4	360	164	620	283	1000	462	580	264	980	445	1700	763		
			75	5.2	620	280	970	440	1600	735	840	381	1900	859	2500	1150		
			100	6.9	870	397	1300	595	2200	987	1100	517	2800	1270	3400	1550		
			150	10.3	910	413	1400	648	2200	1020	2500	1120	3700	1690	4000	1820		
			200	13.8	990	450	1500	684	2300	1030	3800	1740	4700	2150	4700	2150		
			250	17.2	1200	566	1800	799	2400	1110	4300	1950	4700	2140	4700	2140		
			300	20.7	1500	682	2000	915	2600	1190	4700	2140	4700	2140	4700	2140		
			50	3.4	60	4.1	590	266	1200	551	2000	887	630	287	1400	653	2000	887
					75	5.2	850	386	1500	668	2300	1040	940	427	1900	850	2400	1100
	100	6.9			1200	523	1800	822	2800	1290	1500	684	3000	1340	3300	1510		
	150	10.3			1300	576	2000	932	3100	1420	3400	1530	4800	2180	4800	2170		
	200	13.8			1400	631	2300	1040	3400	1530	5200	2370	6100	2760	6400	2930		
	250	17.2			1800	825	2600	1180	3700	1700	6000	2750	6500	2940	6400	2930		
	75	5.2	300	20.7	2200	998	2900	1330	4100	1870	6900	3130	6900	3130	6900	3120		
			100	6.9	1300	571	2100	974	3000	1370	1500	672	2800	1260	3100	1430		
			125	8.6	1600	707	2600	1190	3600	1640	2400	1110	3600	1650	4000	1800		
			150	10.3	1900	844	3100	1420	4200	1890	3400	1570	4400	2000	4800	2190		
			200	13.8	2500	1110	4100	1870	5200	2370	5300	2390	6100	2780	6400	2910		
			250	17.2	2700	1230	4200	1910	5600	2550	7400	3360	7800	3550	7800	3530		
	60 to 120 / 4.1 to 8.3	100	6.9	300	20.7	2100	932	4000	1800	6500	2950	7900	3570	9100	4150	9100	4130	
				125	8.6	1500	674	2700	1220	3600	1630	1700	776	3100	1420	3800	1730	
				150	10.3	1700	750	2900	1310	4100	1880	2700	1220	4000	1820	4700	2130	
				175	12.1	1800	827	3100	1410	4800	2190	3700	1670	4900	2210	5300	2390	
				225	15.5	2200	980	3600	1610	5700	2570	5700	2600	6600	2990	7000	3170	
				250	17.2	2100	957	3700	1670	6100	2760	6600	2990	7400	3380	7800	3550	
100 to 140 / 6.9 to 9.7	125	8.6	300	20.7	4200	1910	6600	2980	8300	3750	7500	3390	9200	4180	9400	4260		
			150	10.3	1800	818	3100	1400	4200	1890	1700	777	3400	1550	4400	2020		
			175	12.1	2100	935	3700	1680	4900	2210	2000	894	4500	2020	5300	2410		
			200	13.8	2400	1070	4300	1950	5700	2600	2200	1010	5300	2420	6100	2800		
			225	15.5	2800	1270	4900	2210	6600	2980	3600	1630	6200	2810	7000	3180		
			250	17.2	3300	1480	5300	2400	7000	3170	4900	2210	7000	3200	7800	3550		
120 to 150 / 8.3 to 10.3	150	10.3	300	20.7	2800	1280	4800	2200	7900	3570	3300	1480	8400	3800	9300	4230		
			175	12.1	1700	778	3100	1430	4900	2220	1700	778	3400	1550	4900	2220		
			200	13.8	2100	936	3600	1620	5700	2610	2100	957	4100	1880	6000	2740		
			225	15.5	2300	1030	3900	1760	6200	2800	2400	1090	5300	2420	6900	3120		
			250	17.2	2400	1110	4200	1890	6600	2990	2700	1230	6200	2810	7700	3500		
			300	20.7	2800	1280	4800	2200	7900	3570	3300	1480	8400	3800	9300	4230		

1. Capacities are based in lbs/h / kg/h of saturated steam.

Bulletin 71.1:MR95

Table 18. Steam Capacities⁽¹⁾ for 1/4 NPT and 1/2 through 1 in. / DN 15 through 25 Type MR95HT Regulators with Metal Diaphragm

RECOMMENDED OUTLET/ DIFFERENTIAL PRESSURE RANGE, psig/psi / bar	PRESSURE				REGULATOR BODY SIZE, IN. / DN																	
	Outlet/ Differential Setting		Inlet		1/4 NPT				1/2 / 15				3/4 / 20				1 / 25					
					Droop				Droop				Droop				Droop					
					10%		20%		10%		20%		10%		20%		10%		20%			
	psig	bar	psig	bar	lb/h	kg/h	lb/h	kg/h	lb/h	kg/h	lb/h	kg/h	lb/h	kg/h	lb/h	kg/h	lb/h	kg/h	lb/h	kg/h		
15 to 100 / 1.0 to 6.9	15	1.0	30	2.1	4.8	2.19	7.2	3.28	8.5	3.85	9.9	4.49	27	12.1	60	27.5	48	22	87	39.5		
			40	2.8	5	2.28	7.8	3.57	15	6.64	19	8.58	36	16.4	70	31.6	53	24	94	42.5		
			50	3.4	5.2	2.37	8.3	3.75	19	8.76	26	11.9	41	18.5	76	34.7	57	26.1	98	44.4		
			75	5.2	5.4	2.44	9.3	4.25	28	12.8	38	17.1	54	24.7	90	40.8	69	31.2	110	51.5		
			100	6.9	5.8	2.65	11	4.78	28	12.8	44	20.2	66	29.9	100	45.9	78	35.2	130	58.7		
			150	10.3	8.6	3.93	14	6.48	42	19.1	61	27.6	70	31.9	110	50	98	44.7	160	73.3		
			200	13.8	12	5.31	18	8.18	56	25.5	77	35.1	77	35.1	120	53.1	120	55.2	190	87.1		
			250	17.2	12	5.42	19	8.82	56	25.5	77	35.1	86	39.3	130	57.4	130	58.4	210	96.7		
			300	20.7	12	5.52	21	9.56	56	25.5	77	35.1	98	44.6	140	61.6	140	62.7	230	106		
			400	27.6	15	6.8	22	10.1	63	28.7	84	38.2	100	46.8	140	64.8	160	71.2	260	117		
			500	34.5	18	8.29	23	10.6	65	29.7	96	43.6	110	48.9	150	68	170	76.5	280	128		
			600	41.4	21	9.67	26	11.7	68	30.8	110	48.9	110	52.1	160	71.2	180	81.8	300	138		
	50	3.4	60	4.1	21	9.77	36	16.6	73	33.3	120	56.4	160	72.3	240	111	150	66.7	270	122		
			75	5.2	22	10.1	38	17.5	78	35.3	130	58.2	170	75.1	240	110	160	74	290	132		
			100	6.9	24	10.8	38	17.3	84	38.2	140	61.9	180	79.8	260	120	190	86.4	310	142		
			150	10.3	26	11.7	42	19.2	100	46.2	160	70.7	190	88.5	280	129	240	108	400	183		
			200	13.8	30	13.8	49	22.3	120	54.4	180	79.8	220	98.6	330	150	310	139	470	214		
			250	17.2	33	14.9	51	23.4	130	60.6	190	87.2	230	107	350	160	350	160	540	245		
			300	20.7	37	17	54	24.4	140	65.9	210	95.6	260	117	370	170	400	181	580	266		
			400	27.6	40	18.1	56	25.5	160	74.4	220	98.8	220	98.8	330	149	440	202	680	308		
			500	34.5	40	18.1	58	26.6	170	76.5	220	101	230	106	350	159	490	223	720	329		
			600	41.4	42	19.1	58	26.6	170	78.6	220	102	260	117	370	170	540	244	770	351		
			100	6.9	125	8.6	49	22.1	75	34.1	160	73.1	240	110	290	133	460	210	320	144	530	243
					150	10.3	51	23	79	36	170	79.2	260	120	320	143	510	230	390	176	630	285
175	12.1	53			23.9	83	37.9	190	85.3	290	131	360	164	550	251	460	208	740	338			
200	13.8	57			26	88	39.8	200	91.3	310	141	380	175	600	272	500	229	860	391			
250	17.2	61			27.8	92	41.6	230	106	350	161	450	206	640	291	600	271	950	432			
300	20.7	66			29.8	96	43.6	260	118	380	171	500	226	690	311	690	312	1100	483			
400	27.6	72			32.9	100	45.7	280	128	420	191	380	171	590	267	780	353	1200	534			
500	34.5	72			32.9	100	46.7	280	127	400	181	420	192	630	287	840	383	1300	575			
600	41.4	75			34	110	47.8	280	127	400	181	440	202	650	298	910	415	1300	606			
80 to 300 / 5.5 to 20.7	125	8.6			150	10.3	34	15.5	56	25.3	110	49.9	180	83.9	230	107	390	177	240	108	410	188
					175	12.1	36	16.5	58	26.2	120	56.2	200	92.2	270	121	410	187	270	121	460	209
					200	13.8	38	17.5	62	28.3	140	62.5	220	100	290	132	460	208	310	143	510	230
			225	15.5	41	18.5	64	29.2	140	65.5	230	106	310	142	480	218	340	153	550	251		
			250	17.2	43	19.5	69	31.2	150	69.6	240	108	340	153	530	239	360	164	600	272		
			300	20.7	47	21.4	75	34.2	170	76.6	280	129	360	163	590	270	430	195	690	313		
			400	27.6	51	23.4	82	37.2	210	95.2	330	149	400	183	640	289	520	236	850	386		
			500	34.5	58	26.6	91	41.4	230	106	370	170	450	203	680	309	610	278	960	437		
			600	41.4	63	28.7	100	45.7	260	117	400	181	470	213	700	319	700	320	1100	489		
			200	13.8	225	15.5	56	25.6	97	44.2	200	89	340	155	390	178	660	299	440	200	760	344
					250	17.2	63	28.7	100	46.1	220	99.7	360	165	440	200	730	331	490	222	830	375
					300	20.7	72	32.9	110	51.2	270	121	410	186	510	231	870	395	560	253	960	438
	350	24.1			77	34.8	120	55.1	290	131	480	217	580	263	1000	458	650	296	1100	512		
	400	27.6			78	35.6	130	58	330	152	520	238	650	294	1100	521	740	338	1300	575		
	450	31.0			83	37.6	130	59.9	360	162	540	248	640	293	1100	508	810	369	1400	616		
	500	34.5			87	39.6	140	61.8	360	162	570	257	670	303	1100	496	880	400	1400	657		
	600	41.4			94	42.5	140	65.9	400	182	630	288	690	312	1100	483	1000	473	1600	740		
	300	20.7			350	24.1	98	44.4	160	74.9	340	155	580	265	610	278	970	443	780	356	1400	620
					400	27.6	110	48.5	170	78.8	410	188	680	308	630	287	990	451	900	409	1600	715
					450	31.0	110	51.4	180	82.7	430	198	720	328	750	341	1200	526	1000	462	1800	800
					500	34.5	120	54.4	190	86.6	480	219	770	348	840	384	1300	600	1100	515	1900	884
			550	37.9	130	57.4	200	90.5	500	229	810	369	960	437	1500	674	1300	579	2100	968		
			600	41.4	130	60.4	210	94.5	550	250	860	389	1100	479	1700	759	1400	632	2300	1040		

1. Capacities are based in lbs/h / kg/h of saturated steam.

Table 19. Steam Capacities⁽¹⁾ for 1-1/2 through 2 in. / DN 40 through 50 Type MR95HT Regulators with Metal Diaphragm

RECOMMENDED OUTLET/ DIFFERENTIAL PRESSURE RANGE, psig/psi / bar	PRESSURE				REGULATOR BODY SIZE, IN. / DN																
	Outlet/ Differential Setting		Inlet		1-1/2 / 40						2 / 50										
					Droop						Droop										
					10%		20%		40%		10%		20%		40%						
psig	bar	psig	bar	lb/h	kg/h	lb/h	kg/h	lb/h	kg/h	lb/h	kg/h	lb/h	kg/h	lb/h	kg/h	lb/h	kg/h				
15 to 100 / 1.0 to 6.9	15	1.0	30	2.1	160	73.4	240	110	440	200	160	73.4	270	123	520	237					
			40	2.8	200	91	300	138	520	235	230	104	370	169	720	326					
			50	3.4	240	109	370	168	590	270	290	134	480	217	910	414					
			75	5.2	330	150	510	233	820	375	430	197	1000	465	1500	678					
			100	6.9	430	196	630	285	1100	479	590	267	1600	729	2100	940					
			150	10.3	470	212	780	353	1200	547	1700	760	2300	1060	2600	1160					
			200	13.8	500	229	890	405	1300	598	2800	1250	3100	1410	3100	1410					
			250	17.2	540	246	850	387	1300	598	1700	792	3100	1430	3100	1420					
			300	20.7	580	264	850	387	1400	615	1400	615	3200	1440	3200	1440					
			400	27.6	430	193	660	299	1400	615	1400	615	3200	1440	3200	1440					
	500	34.5	300	135	460	211	1400	615	1400	615	3200	1440	3200	1440							
	600	41.4	430	193	540	246	1400	615	1400	615	3200	1440	3200	1440							
	50	3.4	60	4.1	450	204	850	388	1500	696	530	241	970	443	1800	803					
			75	5.2	570	257	1100	495	1900	873	770	349	1600	715	2300	1030					
			100	6.9	760	346	1400	654	2500	1140	1100	492	2600	1160	3000	1370					
			150	10.3	1100	486	2000	915	3100	1430	3100	1400	3900	1790	4300	1960					
			200	13.8	1300	607	2600	1180	3800	1720	5100	2320	5500	2500	5800	2650					
			250	17.2	1600	747	2700	1240	3800	1720	3600	1640	6200	2840	6200	2830					
			300	20.7	1900	886	2900	1330	3800	1710	3600	1630	7000	3180	7000	3180					
			400	27.6	1800	812	2700	1230	3800	1710	3600	1620	7000	3170	7000	3170					
			500	34.5	1600	740	2600	1160	3800	1710	3600	1620	7000	3170	7000	3170					
			600	41.4	1000	475	2100	950	3800	1720	3600	1620	7000	3170	7000	3160					
	100	6.9	125	8.6	1200	536	2300	1030	3400	1570	1600	739	3000	1380	3500	1570					
			150	10.3	1500	698	3000	1370	4000	1810	2900	1320	3900	1790	4200	1930					
			200	13.8	2200	981	4400	1990	5500	2520	5400	2480	5600	2530	5700	2600					
			250	17.2	2300	1060	4400	1980	5900	2680	7000	3170	7000	3200	7100	3250					
			300	20.7	2600	1170	4300	1970	6700	3030	8400	3830	8500	3850	8500	3880					
			400	27.6	2700	1210	4700	2130	6600	3010	9000	4100	9000	4090	9300	4250					
			500	34.5	2800	1260	4700	2130	7000	3180	9000	4080	9000	4070	9300	4240					
			600	41.4	3200	1430	5100	2300	7000	3170	8900	4070	8900	4060	9300	4230					
			60 to 260 / 4.1 to 17.9	125	8.6	150	10.3	940	426	1500	682	2900	1300	1100	481	1900	848	3700	1660		
						175	12.1	1100	497	1800	806	3300	1510	1200	552	2300	1040	4400	2000		
	200	13.8				1200	568	2000	930	3800	1720	1400	641	2700	1220	5200	2350				
	225	15.5				1400	620	2200	1020	4000	1800	1600	747	3500	1580	5900	2700				
	250	17.2				1500	690	2400	1090	4300	1980	1900	872	4400	1990	6700	3050				
	300	20.7				1700	795	2700	1220	5100	2320	2400	1100	5900	2700	8300	3750				
400	27.6	2100				967	3500	1590	5500	2490	2900	1310	7100	3220	9000	4090					
500	34.5	2500				1120	4300	1960	6200	2830	3300	1500	8200	3730	10,000	4600					
600	41.4	2900				1330	4700	2130	7000	3180	3600	1650	9400	4250	11,000	4940					
200	13.8	225		15.5	1600	724	2800	1260	5200	2380	1800	798	3500	1570	5800	2650					
		250		17.2	1800	831	3100	1400	5600	2550	2000	905	4000	1840	6600	3020					
		300		20.7	2300	1050	3800	1720	6800	3080	2500	1140	6000	2740	8200	3720					
		350		24.1	2600	1170	4400	2000	7500	3420	2900	1310	7200	3270	9700	4400					
		400		27.6	2800	1290	4800	2170	8300	3770	3200	1450	8400	3800	11,000	4840					
		450		31.0	3100	1430	5200	2340	9100	4110	3500	1590	9100	4140	12,000	5370					
		500		34.5	3400	1550	5500	2520	9800	4460	3800	1710	9900	4490	13,000	5710					
		600		41.4	3900	1790	6700	3040	11,000	4980	4300	1970	11,000	5180	14,000	6400					
		250		17.2	275	19.0	2200	984	3800	1740	6400	2920	2100	947	4500	2030	7000	3190			
300	20.7				2600	1170	4500	2030	7600	3460	2600	1170	5300	2390	7800	3570					
350	24.1				3000	1340	4800	2200	8400	3810	3300	1490	7200	3290	9200	4170					
400	27.6				3400	1540	5600	2550	9500	4330	3700	1680	8400	3830	10,000	4690					
450	31.0				3800	1730	6400	2900	10,000	4680	4000	1820	9200	4170	11,000	5220					
500	34.5				4400	2000	6800	3070	11,000	5200	4800	2180	10,000	4700	12,000	5560					
550	37.9				4400	1990	7100	3240	12,000	5550	4800	2170	11,000	4870	13,000	6080					
600	41.4				4400	1980	7500	3420	13,000	5890	5200	2350	11,000	5210	14,000	6430					

1. Capacities are based in lbs/h / kg/h of saturated steam.
 - Denotes capacities limited by boost.

Table 21. Water Capacities⁽¹⁾⁽²⁾ in GPM / L/min for 1/4 NPT and 1/2 through 1 in. / DN 15 through 25 Types MR95H and MR95HD Regulators with Elastomer Diaphragm

RECOMMENDED OUTLET/ DIFFERENTIAL PRESSURE RANGE, psig/psi / bar	PRESSURE				REGULATOR BODY SIZE, IN. / DN																	
	Outlet/ Differential Setting		Inlet		1/4 NPT				1/2 / 15				3/4 / 20				1 / 25					
					Droop				Droop				Droop				Droop					
					10%		20%		10%		20%		10%		20%		10%		20%			
	psig	bar	psig	bar	GPM	l/min	GPM	l/min	GPM	l/min	GPM	l/min	GPM	l/min	GPM	l/min	GPM	l/min	GPM	l/min		
15 to 30 / 1.0 to 2.1	15	1.0	30	2.1	1.0	3.8	3.0	11.3	4.0	15.1	7.0	26.5	7.0	26.5	12.0	45.4	8.0	30.3	15.0	56.7		
			40	2.8	1.5	5.7	3.5	13.2	4.5	17.0	8.0	30.3	8.5	32.2	13.5	51.1	10.0	37.8	19.0	71.9		
			50	3.4	2.0	7.6	4.0	15.1	5.0	18.9	9.0	34.0	10.0	37.8	15.0	56.7	12.0	45.4	23.0	87.0		
			75	5.2	3.0	11.3	6.0	22.7	6.0	22.7	10.0	37.8	11.5	43.5	17.0	64.3	12.0	45.4	24.0	90.8		
			100	6.9	4.0	15.1	8.0	30.3	7.0	26.5	11.0	41.6	13.0	49.2	19.0	71.9	12.0	45.4	25.0	94.6		
			150	10.3	4.0	15.1	8.0	30.3	9.0	34.0	13.0	49.2	14.5	54.9	20.0	75.7	17.0	64.3	30.5	115		
			200	13.8					11.0	41.6	15.0	56.7	16.0	60.5	21.0	79.4	22.0	83.2	36.0	136		
	250	17.2					12.0	45.4	16.0	60.5	17.0	64.3	22.0	83.2	23.0	87.0	37.0	140				
	300	20.7					13.0	49.2	17.0	64.3												
	30	2.1	40	2.8	2.0	7.5	4.3	16.2	6.0	22.7	10.0	37.8	10.0	37.8	18.0	68.1	12.0	45.4	23.0	87.0		
			50	3.4	3.0	11.3	6.0	22.7	7.0	26.5	12.0	45.4	12.0	45.4	20.0	75.7	15.0	56.7	26.0	98.4		
			75	5.2	4.5	17.0	8.5	32.2	8.5	32.2	14.5	54.9	14.5	54.9	23.5	88.9	21.0	79.4	36.0	136		
			100	6.9	6.0	22.7	11.0	41.6	10.0	37.8	17.0	64.3	17.0	64.3	27.0	102	27.0	102	46.0	174		
			150	10.3	7.6	28.9	13.7	51.9	11.0	41.6	18.0	68.1	18.5	70.0	29.0	110	29.0	110	48.0	182		
200			13.8	8.9	33.6	15.8	59.7	12.0	45.4	19.0	71.9	20.0	75.7	31.0	117	31.0	117	50.0	189			
250			17.2	9.8	37.2	17.4	65.8	13.5	51.1	19.5	73.8	20.5	77.6	32.0	121	38.0	144	57.5	218			
300	20.7	10.6	40.1	18.7	70.7	15.0	56.7	20.0	75.7	21.0	79.4	33.0	125	45.0	170	65.0	246					
25 to 75 / 1.7 to 5.2	50	3.4	60	4.1	3.0	11.4	4.5	17.1	6.8	25.7	13.1	49.5	13.3	50.3	22.8	86.4	17.0	64.3	30.0	113		
			75	5.2	4.0	15.1	6.0	22.7	8.0	30.3	14.0	53.0	14.0	53.0	24.0	90.8	18.0	68.1	31.0	117		
			100	6.9	5.0	18.9	9.0	34.0	9.0	34.0	17.0	64.3	18.0	68.1	29.0	110	25.0	94.6	41.0	155		
			150	10.3	6.5	24.6	11.5	43.5	10.0	37.8	18.0	68.1	21.0	79.4	34.0	129	27.0	102	48.0	182		
			200	13.8	8.0	30.3	14.0	53.0	11.0	41.6	19.0	71.9	24.0	90.8	39.0	148	29.0	110	55.0	208		
			250	17.2	8.8	33.1	15.7	59.5	12.5	47.3	21.0	79.4	24.5	92.7	39.0	148	36.0	136	61.0	231		
			300	20.7	9.5	35.9	17.2	65.0	14.0	53.0	23.0	87.0	25.0	94.6	39.0	148	43.0	163	67.0	253		
	75	5.2	100	6.9	5.0	18.9	8.0	30.3	10.0	37.8	18.0	68.1	18.0	68.1	30.0	113	22.0	83.2	38.0	144		
			125	8.6	6.0	22.7	9.5	35.9	11.3	42.6	19.5	73.8	20.5	77.6	33.3	126	27.5	104	46.3	175		
			150	10.3	7.0	26.5	11.0	41.6	12.5	47.3	21.0	79.4	23.0	87.0	36.5	138	33.0	125	54.5	206		
			200	13.8	9.0	34.0	14.0	53.0	15.0	56.7	24.0	90.8	28.0	106	43.0	163	44.0	166	71.0	269		
			250	17.2	10.1	38.4	15.7	59.4	15.5	58.6	25.0	94.6	30.0	113	46.5	176	46.5	176	74.0	280		
			300	20.7	11.2	42.4	17.3	65.4	16.0	60.5	26.0	98.4	32.0	121	50.0	189	49.0	185	77.0	291		
			70 to 150 / 4.8 to 10.3	100	6.9	125	8.6	4.0	15.1	7.0	26.5	8.3	31.2	14.3	53.9	19.0	71.9	31.0	117	22.0	83.2	37.0
150	10.3	5.0				18.9	9.0	34.0	10.5	39.7	18.0	68.1	23.0	87.0	37.0	140	28.0	106	46.0	174		
175	12.1	6.0				22.7	11.0	41.6	11.6	44.0	20.3	76.6	26.0	98.4	40.5	153	33.0	125	54.0	204		
200	13.8	7.0				26.5	13.0	49.2	12.8	48.2	22.5	85.1	29.0	110	44.0	166	38.0	144	62.0	235		
250	17.2	8.3				31.5	15.7	59.3	13.5	51.1	22.5	85.1	31.0	117	47.5	180	43.0	163	73.0	276		
300	20.7	9.5				35.9	18.0	68.1	14.3	53.9	22.5	85.1	33.0	125	51.0	193	48.0	182	84.0	318		
150	10.3	175		12.1	5.0	18.9	9.0	34.0	9.0	34.0	16.5	62.4	23.0	87.0	39.0	148	30.0	113	44.0	166		
		200		13.8	7.0	26.5	12.0	45.4	12.8	48.2	20.3	76.6	28.0	106	45.0	170	36.0	136	52.0	197		
		225		15.5	8.0	30.3	13.5	51.1	13.9	52.5	22.1	83.7	30.5	115	48.3	183	41.3	156	59.5	225		
		250		17.2	9.0	34.0	15.0	56.7	15.0	56.7	24.0	90.8	33.0	125	51.5	195	46.5	176	67.0	253		
		300		20.7	11.0	41.6	18.0	68.1	17.3	65.3	27.8	105	38.0	144	58.0	219	57.0	216	82.0	310		

1. To obtain capacities for regulators with metal diaphragms, multiply the table values by 0.6.
2. To obtain capacities for regulators with reduced flow orifices, multiply the table values by 0.7.
■ - Capacities not tested due to cavitation regime.

Bulletin 71.1:MR95

Table 22. Water Capacities⁽¹⁾ in GPM / L/min for 1-1/2 through 2 in. / DN 40 through 50 Types MR95H and MR95HD Regulators with Elastomer Diaphragm

RECOMMENDED OUTLET/ DIFFERENTIAL PRESSURE RANGE, psig/psi / bar	PRESSURE				REGULATOR BODY SIZE, IN. / DN													
	Outlet/ Differential Setting		Inlet		1-1/2 / 40						2 / 50							
					Droop						Droop							
					10%		20%		40%		10%		20%		40%			
	psig	bar	psig	bar	GPM	l/min	GPM	l/min	GPM	l/min	GPM	l/min	GPM	l/min	GPM	l/min		
5 to 80 / 0.34 to 5.5	5	0.34	10	0.69	6.0	22.7	8.0	30.3	14.0	53.0	6.0	22.7	8.0	30.3	14.0	53.0		
			20	1.4	8.5	32.2	11.3	42.6	19.8	74.7	8.3	31.2	10.5	39.7	13.0	49.2	21.0	79.4
			30	2.1	11.0	41.6	14.5	54.9	25.5	96.5	10.5	39.7	13.0	49.2	21.0	79.4	28.0	106
			50	3.4	16.0	60.5	21.0	79.4	37.0	140	15.0	56.7	18.0	68.1	28.0	106	37.0	140
			75	5.2	27.5	104	38.0	144	52.5	199	19.0	71.9	25.0	94.6	37.0	140	43.1	164
			100	6.9	39.0	148	55.0	208	68.0	257	23.0	87.0	30.0	113	43.1	164	50.0	188
			150	10.3	47.0	178	98.5	373	119	448	40.5	153	79.0	299	99.5	376	138	522
			200	13.8	55.0	208	142	537	169	639	58.0	219	66.0	250	85.0	322	199	749
			250	17.2	72.5	274	159	600	174	658	52.5	199	59.5	225	75.0	284	200	762
			300	20.7	90.0	340	175	662	179	677	47.0	178	53.0	200	65.0	246	200	762
	15	1.0	30	2.1	14.0	53.0	27.0	102	47.0	178	14.0	53.0	22.0	83.2	42.0	159		
			40	2.8	19.5	73.8	33.0	125	53.5	202	18.0	68.1	28.5	108	52.0	197		
			50	3.4	25.0	94.6	39.0	148	60.0	227	22.0	83.2	35.0	132	62.0	235		
			75	5.2	31.5	119	49.5	187	74.0	280	25.0	94.6	40.0	151	118	445		
			100	6.9	38.0	144	60.0	227	88.0	333	30.0	113	49.0	188	140	530		
			150	10.3	67.5	255	84.5	320	148	560	40.5	153	79.0	299	99.5	376		
			200	13.8	97.0	367	109	412	208	787	58.0	219	66.0	250	85.0	322		
			250	17.2	115	433	184	694	235	889	82.0	310	107	403	132	497		
			300	20.7	132	499	258	976	262	991	73.0	276	97.0	367	130	492		
			50	3.4	60	4.1	27.9	106	63.7	241	95.0	359	25.5	96.7	50.7	192	100	378
75	5.2	34.0			129	66.0	250	111	420	37.0	140	68.0	257	127	480			
100	6.9	51.0			193	95.0	359	138	522	47.0	178	82.0	310	157	594			
150	10.3	62.0			235	103	390	169	639	64.0	242	108	407	198	747			
200	13.8	73.0			276	111	420	200	757	81.0	306	133	503	238	900			
250	17.2	99.5			376	179	677	236	891	85.0	322	140	530	267	1010			
300	20.7	126			477	247	934	271	1030	154	583	178	673	295	1120			
75	5.2	100			6.9	47.0	178	84.0	318	129	488	45.0	170	82.0	310	138	522	
		125			8.6	55.3	209	94.8	358	150	567	54.3	205	97.8	370	161	608	
		150			10.3	63.5	240	106	399	171	647	63.5	240	114	429	184	694	
		200	13.8	80.0	303	127	480	213	806	82.0	310	145	549	229	866			
		250	17.2	87.0	329	189	713	241	912	85.0	322	150	567	260	982			
		300	20.7	94.0	356	250	946	269	1020	191	723	276	1040	290	1100			
60 to 120 / 4.1 to 8.3	100	6.9	125	8.6	47.0	178	92.0	348	135	511	46.0	174	90.0	340	147	556		
			150	10.3	55.8	211	107	404	155	587	54.8	207	106	401	170	643		
			175	12.1	64.5	244	122	460	176	664	63.5	240	122	462	193	730		
			225	15.5	82.0	310	151	571	216	817	81.0	306	154	583	239	904		
			250	17.2	88.3	334	154	581	229	868	85.3	323	163	617	255	965		
			300	20.7	101	382	159	601	256	968	94.0	356	181	685	287	1090		
100 to 140 / 6.9 to 9.7	125	8.6	150	10.3	43.7	165	86.4	327	148	560	47.0	178	91.0	344	158	598		
			175	12.1	55.4	209	105	398	168	636	58.5	221	110	414	183	690		
			200	13.8	67.0	253	124	469	188	711	70.0	265	128	484	207	783		
			225	15.5	74.5	282	139	526	204	773	78.3	296	142	535	224	847		
			250	17.2	82.0	310	154	583	221	834	86.5	327	155	586	241	912		
			300	20.7	97.0	367	184	696	253	957	103	390	182	689	275	1040		
120 to 150 / 8.3 to 10.3	150	10.3	175	12.1	40.0	151	79.0	299	145	549	42.0	159	90.0	340	169	639		
			200	13.8	52.0	197	98.0	371	169	639	56.0	212	108	409	198	749		
			225	15.5	59.5	225	108	409	188	709	63.8	241	121	459	215	812		
			250	17.2	67.0	253	118	446	206	779	71.5	270	135	509	232	876		
			300	20.7	82.0	310	138	522	243	919	87.0	329	161	609	265	1000		

1. To obtain capacities for regulators with reduced flow orifices, multiply the table values by 0.7.

■ - Denotes capacities limited by boost.

Table 23. Water Capacities⁽¹⁾⁽²⁾ in GPM / L/min for 1/4 NPT and 1/2 through 1 in. / DN 15 through 25 Type MR95HP (Elastomer Diaphragm) Regulator

RECOMMENDED OUTLET/ DIFFERENTIAL PRESSURE RANGE, psig/psi / bar	PRESSURE				REGULATOR BODY SIZE, IN. / DN																
	Outlet/ Differential Setting		Inlet		1/4 NPT				1/2 / 15				3/4 / 20				1 / 25				
					Droop		Droop		Droop		Droop										
					10%		20%		10%		20%		10%		20%		10%		20%		
	psig	bar	psig	bar	GPM	l/min	GPM	l/min	GPM	l/min	GPM	l/min	GPM	l/min	GPM	l/min	GPM	l/min	GPM	l/min	
15 to 100 / 1.0 to 6.9	15	1.0	30	2.1	0.8	3.0	1.3	4.9	2.4	9.1	3.7	14.0	6.0	22.7	8.0	30.3	6.0	22.7	10.0	37.8	
			40	2.8	1.3	4.9	1.9	7.2	2.9	11.0	4.3	16.3	6.5	24.6	8.5	32.2	7.0	26.5	11.0	41.6	
			50	3.4	1.8	6.8	2.5	9.5	3.4	12.9	4.9	18.5	7.0	26.5	9.0	34.0	8.0	30.3	12.0	45.4	
			75	5.2	2.2	8.1	3.3	12.5	4.3	16.1	6.1	22.9	8.5	32.2	11.5	43.5	9.5	35.9	13.5	51.1	
			100	6.9	2.5	9.5	4.1	15.5	5.1	19.3	7.2	27.2	10.0	37.8	14.0	53.0	11.0	41.6	15.0	56.7	
			150	10.3	2.9	11.0	4.6	17.2	5.8	21.9	8.1	30.6	11.5	43.5	15.5	58.6	13.5	51.1	20.0	75.7	
			200	13.8	3.3	12.5	5.0	18.9	6.5	24.6	9.0	34.0	13.0	49.2	17.0	64.3	16.0	60.5	25.0	94.6	
			250	17.2	3.6	13.6	5.3	20.0	7.6	28.8	10.2	38.4	14.0	53.0	18.0	68.1	18.5	70.0	30.7	116	
			300	20.7	3.9	14.8	5.6	21.2	8.7	32.9	11.3	42.7	15.0	56.7	19.0	71.9	21.0	79.4	36.4	138	
			400	27.6											16.8	63.6	19.0	71.9	24.0	90.8	37.0
	500	34.5																			
	600	41.4																			
	1000	69.0																			
	15 to 100 / 1.0 to 6.9	75	5.2	100	6.9	4.2	15.9	7.0	26.5	8.0	30.3	14.0	53.0	16.0	60.5	25.0	94.6	18.0	68.1	31.0	117
				125	8.6	5.5	20.6	8.5	32.1	9.0	34.0	15.5	58.6	18.0	68.1	28.8	109	21.5	81.3	37.3	141
				150	10.3	6.7	25.3	10.0	37.6	10.0	37.8	17.0	64.3	20.0	75.7	32.5	123	25.0	94.6	43.5	165
				200	13.8	9.2	34.8	12.9	48.8	12.0	45.4	20.0	75.7	24.0	90.8	40.0	151	32.0	121	56.0	212
				250	17.2	10.2	38.4	14.7	55.4	13.0	49.2	21.5	81.3	26.5	100	43.0	163	35.5	134	62.5	236
				300	20.7	11.1	42.0	16.4	62.0	14.0	53.0	23.0	87.0	29.0	110	46.0	174	39.0	148	69.0	261
				400	27.6	12.5	47.3	17.0	64.3	14.5	54.9	23.0	87.0	30.3	115	53.0	200	41.0	155	80.0	303
				500	34.5	13.0	49.2	18.0	68.1	15.0	56.7	23.0	87.0	30.3	115	53.0	200	41.0	155	80.0	303
				600	41.4	14.0	53.0	18.0	68.1	15.0	56.7	23.0	87.0	30.3	115	53.0	200	41.0	155	80.0	303
				1000	69.0																
	15 to 100 / 1.0 to 6.9	100	6.9	125	8.6	4.9	18.5	7.0	26.5	9.0	34.0	16.0	60.5	19.0	71.9	32.0	121	21.0	79.4	36.0	136
				150	10.3	6.7	23.3	8.9	33.8	10.7	40.4	18.0	68.1	22.7	85.7	36.7	139	26.7	101	44.0	166
				175	12.1	7.4	28.1	10.9	41.1	12.3	46.7	20.0	75.7	26.3	99.6	41.3	156	32.3	122	52.0	197
				200	13.8	8.7	32.9	12.8	48.4	14.0	53.0	22.0	83.2	30.0	113	46.0	174	38.0	144	60.0	227
				250	17.2	10.3	39.0	14.9	56.4	15.0	56.7	23.5	88.9	31.0	117	50.0	189	42.0	159	68.5	259
				300	20.7	11.9	45.0	17.0	64.3	16.0	60.5	25.0	94.6	32.0	121	54.0	204	46.0	174	77.0	291
				400	27.6	14.2	53.6	20.4	77.2	16.0	60.5	26.0	98.4	33.5	127	56.7	214	51.5	195	81.0	306
500				34.5	16	60.4	23.0	86.9	16.0	60.5	27.0	102	37.1	140	59.5	225	57.0	216	85.0	322	
600				41.4	17.4	65.9	25.1	94.9	18.0	68.1	28.0	106	37.1	140	59.5	225	57.0	216	85.0	322	
1000				69.0					18.0	68.1	28.0	106	37.1	140	59.5	225	57.0	216	85.0	322	
80 to 300 / 5.5 to 20.7	125	8.6	150	10.3	1.9	7.2	3.5	13.2	6.0	22.7	10.0	37.8	10.0	37.8	19.0	71.9	12.0	45.4	25.0	94.6	
			175	12.1	2.4	9.1	4.1	15.5	7.0	26.5	12.0	45.4	13.5	51.1	24.0	90.8	16.0	60.5	30.0	113	
			200	13.8	2.9	11.0	4.7	17.8	8.0	30.3	14.0	53.0	17.0	64.3	29.0	110	20.0	75.7	35.0	132	
			225	15.5	3.2	12.1	5.2	19.5	8.8	33.1	15.0	56.7	18.5	70.0	31.0	117	22.0	83.2	38.0	144	
			250	17.2	3.5	13.2	5.6	21.2	9.5	35.9	16.0	60.5	20.0	75.7	33.0	125	24.0	90.8	41.0	155	
			300	20.7	4.1	15.5	6.5	24.6	11.0	41.6	18.0	68.1	23.0	87.0	37.0	140	28.0	106	47.0	178	
			400	27.6	5.0	18.9	7.7	29.0	11.5	43.5	19.0	71.9	26.0	98.4	39.5	149	36.0	136	57.5	218	
			500	34.5	5.7	21.6	8.6	32.6	12.0	45.4	20.0	75.7	29.0	110	42.0	159	44.0	166	68.0	257	
			600	41.4	6.3	23.8	9.4	35.6	14.0	53.0	22.0	83.2	29.3	111	43.2	163	45.0	170	72.0	272	
	1000	69.0					14.0	53.0	22.0	83.2	32.5	123	51.0	193	50.0	189	85.0	322			
	80 to 300 / 5.5 to 20.7	200	13.8	225	15.5	2.6	9.8	5.0	18.9	8.0	30.3	15.0	56.7	16.0	60.5	30.0	113	19.0	71.9	37.0	140
				250	17.2	3.1	11.6	5.7	21.4	9.3	35.3	17.0	64.3	19.0	71.9	34.7	131	23.0	87.0	42.3	160
				300	20.7	4.0	15.1	7.0	26.5	12.0	45.4	21.0	79.4	25.0	94.6	44.0	166	31.0	117	53.0	200
				400	27.6	5.4	20.4	9.0	34.0	15.0	56.7	25.0	94.6	29.5	112	49.0	185	37.5	142	65.0	246
				500	34.5	6.5	24.6	10.6	39.9	18.0	68.1	29.0	110	34.0	129	54.0	204	44.0	166	77.0	291
				600	41.4	7.4	27.9	11.8	44.8	19.0	71.9	31.0	117	37.0	140	57.0	216	45.0	170	82.0	310
	1000	69.0	9.9	37.4	15.4	58.3	20.0	75.7	32.0	121	40.0	151	60.0	227	75.0	284	125	473			
	80 to 300 / 5.5 to 20.7	300	20.7	350	24.1	4.6	17.2	8.1	30.5	13.0	49.2	23.0	87.0	24.0	90.8	44.0	166	27.0	102	53.0	200
400				27.6	5.3	19.9	9.1	34.4	15.0	56.7	26.0	98.4	28.0	106	49.0	185	33.0	125	63.3	240	
500				34.5	6.7	25.2	11.2	42.4	19.0	71.9	32.0	121	36.0	136	59.0	223	45.0	170	84.0	318	
600				41.4	7.4	27.8	12.3	46.3	21.0	79.4	35.0	132	42.0	159	65.0	246	59.0	223	98.0	371	
1000	69.0	9.1	34.4	15.8	59.6	26.0	98.4	45.0	170	50.0	189	77.0	291	70.0	265	127	480				
80 to 400 / 5.5 to 27.6 Type MR95HP Only	400	27.6	500	34.5	6.7	25.2	11.2	42.4	19.0	71.9	32.0	121	32.0	121	55.0	208	43.0	163	73.0	276	
			600	41.4	7.7	29.1	13.0	49.0	22.0	83.2	37.0	140	40.0	151	65.0	246	52.0	197	92.0	348	
			1000	69.0	10.6	40.3	17.9	67.5	30.4	115	51.0	193	53.0	200	84.0	318	84.0	318	135	511	

1. To obtain capacities for regulators with metal diaphragms or for Type MR95HT, multiply the table values by 0.6. Capacity data for 1000 psig / 69.0 bar inlet is not applicable for Type MR95HT (Type MR95HT max. inlet = 600 psig / 41.4 bar).

2. To obtain capacities for regulators with reduced flow orifices, multiply the table values by 0.7.

■ - Capacities not tested due to cavitation regime.

Bulletin 71.1:MR95

Table 24. Water Capacities⁽¹⁾⁽²⁾ in GPM / L/min for 1-1/2 through 2 in. / DN 40 through 50 Type MR95HP (Elastomer Diaphragm) Regulator

RECOMMENDED OUTLET/ DIFFERENTIAL PRESSURE RANGE, psig/psi / bar	PRESSURE				REGULATOR BODY SIZE, IN. / DN												
	Outlet/ Differential Setting		Inlet		1-1/2 / 40						2 / 50						
					Droop				Droop								
					10%		20%		40%		10%		20%		40%		
psig	bar	psig	bar	GPM	l/min	GPM	l/min	GPM	l/min	GPM	l/min	GPM	l/min	GPM	l/min		
15 to 100 / 1.0 to 6.9	15	1.0	30	2.1	12.0	45.4	20.0	75.7	36.0	136	11.0	41.6	18.0	68.1	33.0	125	
			40	2.8	15.5	58.6	25.0	94.6	41.5	157	15.5	58.6	23.0	87.0	40.5	153	
			50	3.4	19.0	71.9	30.0	113	47.0	178	20.0	75.7	28.0	106	48.0	182	
			75	5.2	23.0	87.0	36.5	138	59.5	225	22.5	85.1	32.0	121	59.0	223	
			100	6.9	27.0	102	43.0	163	72.0	272	25.0	94.6	36.0	136	70.0	265	
			150	10.3	41.0	155	62.0	235	134	505	35.0	132	139	526	158	596	
			200	13.8	55.0	208	81.0	306	195	738	45.0	170	242	915	245	927	
			250	17.2	76.5	289	148	560	217	819	98.0	371	115	435	132	499	
			300	20.7	98.0	371	215	813	238	900	98.0	371	115	435	132	499	
			400	27.6													
	500	34.5															
	600	41.4															
	1000	69.0															
	50	3.4	60	4.1	19.0	71.9	39.0	148	81.0	306	20.0	75.7	41.0	155	91.0	344	
			75	5.2	26.9	102	49.9	189	101	382	27.1	103	54.5	206	112	424	
			100	6.9	40.0	151	68.0	257	134	507	39.0	148	77.0	291	147	556	
			150	10.3	53.0	200	85.5	323	172	651	56.0	212	144	545	192	724	
			200	13.8	66.0	250	103	390	210	794	73.0	276	211	798	236	893	
			250	17.2	86.5	327	147	554	240	908	137	516	231	872	265	1000	
			300	20.7	107.0	405	190	719	270	1020	200	757	250	946	294	1110	
			400	27.6	107.0	405	190	719	270	1020	200	757	250	946	294	1110	
			500	34.5	107.0	405	190	719	270	1020	200	757	250	946	294	1110	
			600	41.4	107.0	405	190	719	270	1020	200	757	250	946	294	1110	
	1000	69.0															
	100	6.9	125	8.6	41.0	155	78.0	295	138	522	42.0	159	91.0	344	146	552	
			150	10.3	52.3	198	95.7	362	159	603	57.3	217	117	444	169	639	
			175	12.1	63.7	241	113	429	181	683	72.7	275	144	543	192	726	
			200	13.8	75.0	284	131	496	202	764	88.0	333	170	643	215	813	
			250	17.2	83.5	316	145	547	234	883	136	513	219	827	247	934	
			300	20.7	92.0	348	158	598	265	1000	183	692	267	1010	279	1060	
400			27.6	111	422	180	681	265	1000	183	692	267	1010	279	1060		
500			34.5	125	471	200	757	265	1000	183	692	267	1010	279	1060		
600			41.4	135	512	200	757	265	1000	183	692	267	1010	279	1060		
1000			69.0	166	626	200	757	265	1000	183	692	267	1010	279	1060		
60 to 260 / 4.1 to 17.9	125	8.6	150	10.3	28.0	106	55.0	208	111	420	31.0	117	56.0	212	119	450	
			175	12.1	36.5	138	66.5	252	131	496	38.0	144	70.0	265	144	545	
			200	13.8	45.0	170	78.0	295	151	571	45.0	170	84.0	318	169	639	
			225	15.5	51.0	193	85.5	323	168	636	50.8	192	93.3	353	188	711	
			250	17.2	57.0	216	93.0	352	186	702	56.5	214	103	388	207	783	
			300	20.7	69.0	261	108	409	220	832	68.0	257	121	458	245	927	
			400	27.6	75.0	284	125	473	250	946	78.8	298	138	520	275	1040	
			500	34.5	90.0	340	140	530	266	1010	94.5	357	154	583	293	1110	
			600	41.4	100	378	145	549	276	1040	105	397	160	603	303	1150	
			1000	69.0	105	397	150	567	285	1080	110	417	165	624	314	1190	
	200	13.8	225	15.5	38.0	144	76.0	288	160	605	31.0	117	69.0	261	154	583	
			250	17.2	47.7	180	90.0	340	179	677	42.0	159	86.0	325	178	673	
			300	20.7	67.0	253	118	446	217	821	64.0	242	120	454	226	855	
			350	24.1	70.3	266	121	458	220	833	73.8	279	133	504	242	916	
			400	27.6	73.5	278	124	469	226	854	77.2	292	136	516	248	939	
			450	31.0	76.8	290	127	480	231	874	80.6	305	140	528	254	962	
			500	34.5	80.0	303	130	492	237	895	84.0	318	143	541	260	985	
			600	41.4	85.0	322	135	511	246	929	89.3	338	149	562	270	1020	
			1000	69.0	105	397	150	567	273	1030	110	417	165	624	300	1140	
			250	17.2	275	19.0	43.0	163	91.0	344	185	700	45.0	170	95.0	359	194
	300	20.7			50.0	189	101	382	203	768	56.0	212	110	416	219	828	
	350	24.1			55.8	211	108	407	204	773	58.6	222	118	447	225	850	
	400	27.6			61.7	233	114	431	217	819	64.8	245	125	474	238	901	
	450	31.0			67.5	255	121	456	229	866	70.9	268	133	501	252	953	
	500	34.5			73.3	277	127	480	241	913	77.0	291	140	528	265	1000	
	550	37.9			79.2	299	134	505	254	960	83.1	314	147	556	279	1060	
	600	41.4			85.0	322	140	530	266	1010	89.3	338	154	583	293	1110	
	1000	69.0			95.0	359	155	586	295	1110	99.8	377	171	645	324	1230	
	60 to 300 / 4.1 to 20.7 Type MR95HP Only	300			20.7	350	24.1	55.0	208	110	416	209	791	57.8	218	121	458
			400	27.6		68.0	257	125	473	238	898	71.4	270	138	520	261	988
450			31.0	79.0		299	135	511	257	970	83.0	314	149	562	282	1070	
500			34.5	90.0		340	145	549	276	1040	94.5	357	160	603	303	1150	
550			37.9	92.5		350	148	558	280	1060	97.1	367	162	614	308	1170	
600			41.4	95.0		359	150	567	285	1080	99.8	377	165	624	314	1190	
1000	69.0	125	473	190	719	361	1370	131	497	209	791	397	1500				

1. To obtain capacities for Type MR95HT (metal diaphragm), multiply the table values by 0.6. Capacity data for 1000 psig / 69.0 bar inlet is not applicable for Type MR95HT (Type MR95HT max. inlet = 600 psig / 41.4 bar).

2. To obtain capacities for regulators with reduced flow orifices, multiply the table values by 0.7.

☐ - Denotes capacities limited by boost.

■ - Capacities not tested due to cavitation regime.

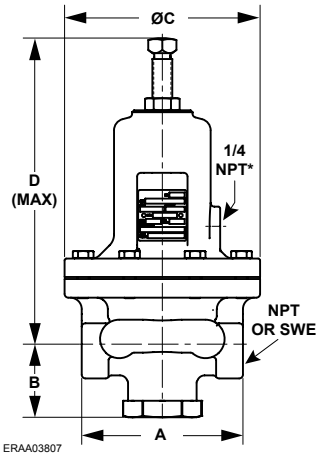

TYPE MR95H (DIMENSION ALSO APPLY TO TYPES MR95L, MR95HT AND MR95HP)

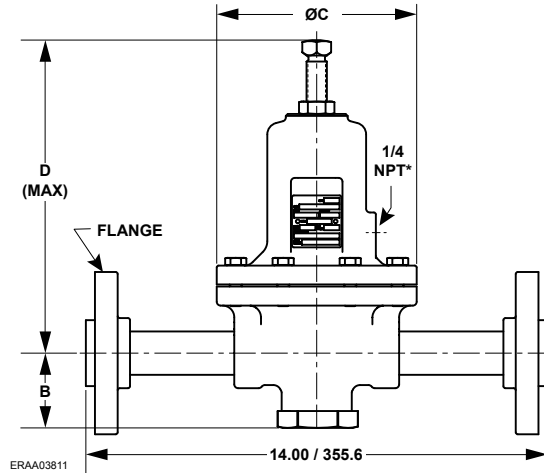

TYPE MR95H FLANGED BODIES AVAILABLE IN 1/2 TO 2 IN. / DN 15 TO 50 BODY SIZES (DIMENSIONS ALSO APPLY TO TYPES MR95L, MR95HT AND MR95HP)

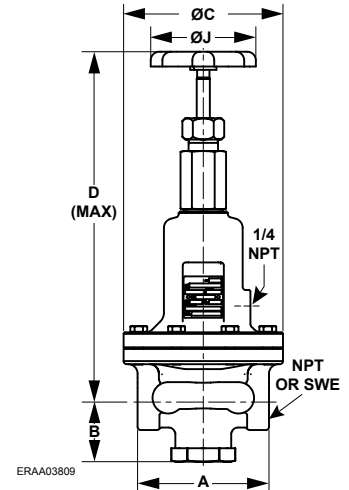

TYPE MR95HD (DIMENSIONS ALSO APPLY TO TYPE MR95LD)

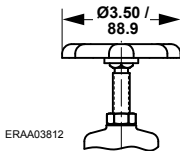

HANDLE DETAIL FOR SIZE 1/2 IN. / DN 15 ONLY

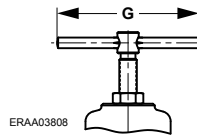

TEE HANDLE DETAIL FOR ALL SIZES EXCEPT 1/2 IN. / DN 15

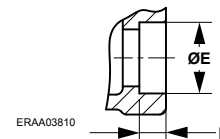

SWE DETAIL

IN. / mm

*Only when specified

Figure 3. Dimensions Drawing

Table 25. Dimensions

TYPE MR95L																
BODY SIZE, IN. / DN	A				B		C		D (Max)		SWE				Tee Handle	
	Gray Cast Iron		Steel/SST		In.	mm	In.	mm	In.	mm	E		F		In.	mm
	In.	mm	In.	mm							In.	mm	In.	mm		
1/4 NPT	2.75	69.9	2.75	69.9	2.04	51.9	5.06	128.5	6.17	156.7	----	----	----	----	3.00	76.2
1/2 / 15	3.88	98.6	4.00	101.6	1.85	47.1	7.00	177.8	7.84	199.2	0.86	21.8	0.38	9.7	----	----
3/4 / 20	4.88	124.0	5.00	127.0	2.27	57.6	10.19	258.8	9.86	250.4	1.07	27.2	0.50	12.7	5.00	127.0
1 / 25	4.88	124.0	5.00	127.0	2.27	57.6	10.19	258.8	9.86	250.4	1.34	34.0	0.50	12.7	5.00	127.0
TYPES MR95H, MR95HT AND MR95HP																
1/4 NPT	2.75	69.9	2.75	69.9	2.04	51.9	3.19	81.0	6.36	161.5	----	----	----	----	3.00	76.2
1/2 / 15	3.88	98.6	4.00	101.6	1.85	47.1	4.25	108.0	8.29	210.6	0.86	21.8	0.38	9.7	----	----
3/4 / 20	4.88	124.0	5.00	127	2.27	57.6	6.06	154.0	10.21	259.4	1.07	27.2	0.50	12.7	5.00	127.0
1 / 25	4.88	124.0	5.00	127	2.27	57.6	6.06	154.0	10.21	259.4	1.34	34.0	0.50	12.7	5.00	127.0
1-1/2 / 40	7.25	184.2	7.38	187.4	3.06	77.7	8.19	208.0	14.78	375.4	1.92	48.8	0.50	12.7	5.00	127.0
2 / 50	7.25	184.2	7.38	187.4	3.06	77.7	8.19	208.0	14.78	375.4	2.07	52.6	0.62	15.8	5.00	127.0
TYPE MR95LD																
BODY SIZE, IN. / DN	A				B		C		D (Max)		SWE				J	
	Gray Cast Iron		Steel/SST		In.	mm	In.	mm	In.	mm	E		F		In.	mm
	In.	mm	In.	mm							In.	mm	In.	mm		
1/4 NPT	2.75	69.9	2.75	69.9	2.04	51.9	5.06	128.5	10.46	265.6	----	----	----	----	4.00	101.6
1/2 / 15	3.88	98.6	4.00	101.6	1.85	47.1	7.00	177.8	11.62	295.2	0.86	21.8	0.38	9.7	4.00	101.6
3/4 / 20	4.88	124.0	5.00	127.0	2.27	57.6	10.19	258.8	13.89	352.8	1.07	27.2	0.50	12.7	4.00	101.6
1 / 25	4.88	124.0	5.00	127.0	2.27	57.6	10.19	258.8	13.89	352.8	1.34	34.0	0.50	12.7	4.00	101.6
TYPE MR95HD																
1/4 NPT	2.75	69.9	2.75	69.9	2.04	51.9	3.19	81.0	10.38	263.7	----	----	----	----	4.00	101.6
1/2 / 15	3.88	98.6	4.00	101.6	1.85	47.1	4.25	108.0	11.52	292.5	0.86	21.8	0.38	9.7	4.00	101.6
3/4 / 20	4.88	124	5.00	127.0	2.27	57.6	6.06	154.0	13.76	349.4	1.07	27.2	0.50	12.7	4.00	101.6
1 / 25	4.88	124	5.00	127.0	2.27	57.6	6.06	154.0	13.76	349.4	1.34	34.0	0.50	12.7	4.00	101.6
1-1/2 / 40	7.25	184.2	7.38	187.4	3.06	77.7	8.19	208.0	18.62	472.9	1.92	48.8	0.50	12.7	8.00	203.2
2 / 50	7.25	184.2	7.38	187.4	3.06	77.7	8.19	208.0	18.62	472.9	2.07	52.6	0.62	15.8	8.00	203.2

Bulletin 71.1:MR95

Ordering Information

When ordering, complete the ordering guide on this page. Refer to the Specifications section on pages 2 and 3.

Review the description to the right of each specification and the information in each referenced table or figure. Specify your choice whenever a selection is offered.

Ordering Guide

Type (Select One)

- MR95L (Low pressure)
- MR95LD (Low pressure differential)
- MR95H (High pressure)
- MR95HD (High pressure differential, must be Steel or Stainless steel construction)
- MR95HP (High pressure, soft-seated)
- MR95HT (High pressure/temperature, must be Steel or Stainless steel construction)

Body Size (Select One)

- 1/4 NPT⁽¹⁾
- 1/2 in. / DN 15
- 3/4 in. / DN 20
- 1 in. / DN 25
- 1-1/2 in. / DN 40 (not available for MR95L Series)
- 2 in. / DN 50 (not available for MR95L Series)

Body Material and End Connection Style⁽²⁾

(See Tables 1 and 2, Select One)

Gray Cast Iron

- NPT***

WCC Steel

- NPT***
- SWE**
- Welded CL150 RF***
- Welded CL300 RF***
- Welded CL600 RF***
- Welded PN 16/25/40 RF***

LCC Steel

- NPT***
- SWE**
- Welded CL150 RF***
- Welded CL300 RF***
- Welded CL600 RF***
- Welded PN 16/25/40 RF***

CF8M Stainless steel

- NPT***
- SWE**
- Welded CL150 RF***
- Welded CL300 RF***
- Welded CL600 RF***

CF3M Stainless steel

- NPT***
- SWE***
- Welded CL150 RF***
- Welded CL300 RF***

Body Material and End Connection Style⁽²⁾

(See Tables 1 and 2, Select One) (continued)

CF3M Stainless steel (continued)

- Welded CL600 RF***
- Welded PN 16/25/40 RF***
- Integral CL150 RF*
- Integral CL300 RF*
- Integral CL600 RF*
- Integral PN 16/25/40 RF*

Hastelloy® C

- NPT*
- Integral CL150 RF*
- Integral CL300 RF*
- Integral CL600 RF*
- Integral PN 16/25/40 RF*

Monel®

- NPT*
- Integral CL150 RF*
- Integral CL300 RF*
- Integral CL600 RF*
- Integral PN 16/25/40 RF*

Aluminum-Bronze

- Integral CL150 RF*
- Integral CL300 RF*
- Integral CL600 RF*
- Integral PN 16/25/40 RF*

Spring Case Material (Select One)

- Gray cast iron (**standard** for gray cast iron bodies)^{(3)***}
- WCC Steel (**standard** for steel or Stainless steel bodies)^{***}
- LCC Steel^{***}
- CF8M Stainless steel (optional for Stainless steel bodies)^{**}
- Hastelloy® C
- Monel®

Trim Material (See Table 7, Select One)

Metal Seat

416 Stainless steel

- Trim 1
- Trim 2
- Trim 22

316 Stainless steel

- Trim 3
- Trim 23

Hastelloy® C

- Trim 5

1. Available in threaded (NPT) end connection only.
2. Integral flanges are available for MR95H Series only.
3. Gray cast iron spring case not available for Types MR95LD and MR95HD.
Monel® is a mark owned by Special Metals Corporation.
Hastelloy® C is a mark owned by Haynes International, Inc.

- continued -

Ordering Guide (continued)

Trim Material (See Table 7, Select One) (continued)

Metal Seat (continued)

Monel®

- Trim 6

Alloy 6⁽¹⁾

- Trim 4
- Trim 24

Elastomer Seat

Nitrile (NBR)

- Trim 7
- Trim 8
- Trim 9
- Trim 10
- Trim 11

Fluorocarbon (FKM)

- Trim 12
- Trim 13
- Trim 14
- Trim 15

Perfluoroelastomer (FFKM)

- Trim 16

Polytetrafluoroethylene (PTFE)

- Trim 17
- Trim 18
- Trim 19

Ethylenepropylene (EPDM)

- Trim 20

Diaphragm (Select One)

- Neoprene (CR)
- Fluorocarbon (FKM)
- Ethylenepropylene (EPDM)
- Monel®
- Hastelloy® C
- 302 Stainless steel
- 302 Stainless steel (Steam Service)⁽²⁾

Outlet or Differential Pressure Range (Select One)

Type MR95L or MR95LD

Steel Spring

- 2 to 6 psig/psi / 0.14 to 0.41 bar, Yellow***
- 5 to 15 psig/psi / 0.34 to 1.0 bar, Green***
- 13 to 30 psig/psi / 0.90 to 2.1 bar, Red***

302 Stainless steel Spring

- 2 to 6 psig/psi / 0.14 to 0.41 bar, Yellow***
- 5 to 15 psig/psi / 0.34 to 1.0 bar, Unpainted***
- 13 to 30 psig/psi / 0.90 to 2.1 bar, Unpainted***

Outlet or Differential Pressure Range

(Select One) (continued)

Type MR95H or MR95HD

1/4 NPT and 1/2 to 1 in. / DN 15 to 25 body sizes

Steel Spring

- 15 to 30 psig/psi / 1.0 to 2.1 bar, Yellow***
- 25 to 75 psig/psi / 1.7 to 5.2 bar, Green***
- 70 to 150 psig/psi / 4.8 to 10.3 bar, Red***

302 Stainless steel Spring⁽³⁾

- 15 to 30 psig/psi / 1.0 to 2.1 bar, Yellow***
- 25 to 75 psig/psi / 1.7 to 5.2 bar, Unpainted***
- 70 to 150 psig/psi / 4.8 to 10.3 bar, Unpainted***

1-1/2 and 2 in. / DN 40 and 50 body sizes

Steel Spring

- 5 to 80 psig/psi / 0.34 to 5.5 bar, Black with light blue stripe***
- 60 to 120 psig/psi / 4.1 to 8.3 bar, Light Gray***
- 100 to 140 psig/psi / 6.9 to 9.7 bar, Yellow***
- 120 to 150 psig/psi / 8.3 to 10.3 bar, Black***

Type MR95HT

1/4 NPT and 1/2 in. / DN 15 body size

Inconel® Spring

- 15 to 100 psig / 1.0 to 6.9 bar, Unpainted***
- 80 to 300 psig / 5.5 to 20.7 bar, Unpainted***

3/4 and 1 in. and DN 20 and 25 body sizes

17-4 PH Stainless steel Spring

- 15 to 100 psig / 1.0 to 6.9 bar, Unpainted***
- 80 to 300 psig / 5.5 to 20.7 bar, Unpainted***

1-1/2 and 2 in. and DN 40 and 50 body sizes

17-4 PH Stainless steel Spring

- 15 to 100 psig / 1.0 to 6.9 bar, Unpainted***
- 60 to 260 psig / 4.1 to 17.9 bar, Unpainted***

Type MR95HP

1/4 NPT and 1/2 in. / DN 15 body size

Inconel® Spring

- 15 to 100 psig / 1.0 to 6.9 bar, Unpainted***
- 80 to 400 psig / 5.5 to 27.6 bar, Unpainted***

3/4 and 1 in. / DN 20 and 25 body sizes

17-4 PH Stainless steel Spring

- 15 to 100 psig / 1.0 to 6.9 bar, Unpainted***
- 80 to 400 psig / 5.5 to 27.6 bar, Unpainted***

1-1/2 and 2 in. / DN 40 and 50 body sizes

17-4 PH Stainless steel Spring

- 15 to 100 psig / 1.0 to 6.9 bar, Unpainted***
- 60 to 300 psig / 4.1 to 20.7 bar, Unpainted***

Replacement Parts Kit (Optional)

- Yes, send one replacement parts kit to match this order.

1. Alloy 6 is not available for 1/4 in. size.

2. Only available with Stainless steel seat, orifice/valve plug, valve plug guide and stem/stem guide.

3. Available for 3/4 and 1 in. / DN 20 and 25 body sizes only.

Monel® and Inconel® are marks owned by Special Metals Corporation.

Hastelloy® C is a mark owned by Haynes International, Inc.

- continued -

Bulletin 71.1:MR95

Ordering Guide (continued)

Regulators Quick Order Guide	
***	Readily Available for Shipment
**	Allow Additional Time for Shipment
*	Special Order, Constructed from Non-Stocked Parts. Consult your local Sales Office for Availability.
Availability of the product being ordered is determined by the component with the longest shipping time for the requested construction.	

Specification Worksheet

Application:
 Specific Use _____
 Line Size _____
 Fluid Type and Specific Gravity _____
 Fluid Temperature _____
 Does the Application Require Overpressure Protection?
 Yes No If yes, which is preferred:
 Relief Valve Monitor Regulator Shutoff Device
 Is overpressure protection equipment selection assistance desired? _____

Pressure:
 Maximum Inlet Pressure (P_{1max}) _____
 Minimum Inlet Pressure (P_{1min}) _____
 Downstream Pressure Setting(s) (P₂) _____
 Maximum Flow (Q_{max}) _____

Performance Required:
 Accuracy Requirements? _____
 Need for Extremely Fast Response? _____

Other Requirements: _____

Industrial Regulators

Emerson Process Management Regulator Technologies, Inc.

USA - Headquarters
 McKinney, Texas 75070 USA
 Tel: +1 800 558 5853
 Outside U.S. +1 972 548 3574

Asia-Pacific
 Shanghai 201206, China
 Tel: +86 21 2892 9000

Europe
 Bologna 40013, Italy
 Tel: +39 051 419 0611

Middle East and Africa
 Dubai, United Arab Emirates
 Tel: +971 4811 8100

Natural Gas Technologies

Emerson Process Management Regulator Technologies, Inc.

USA - Headquarters
 McKinney, Texas 75070 USA
 Tel: +1 800 558 5853
 Outside U.S. +1 972 548 3574

Asia-Pacific
 Singapore 128461, Singapore
 Tel: +65 6770 8337

Europe
 Bologna 40013, Italy
 Tel: +39 051 419 0611
 Chartres 28008, France
 Tel: +33 2 37 33 47 00

Middle East and Africa
 Dubai, United Arab Emirates
 Tel: +971 4811 8100

TESCOM

Emerson Process Management Tescom Corporation

USA - Headquarters
 Elk River, Minnesota 55330-2445, USA
 Tels: +1 763 241 3238
 +1 800 447 1250

Europe
 Selmsdorf 23923, Germany
 Tel: +49 38823 31 287

Asia-Pacific
 Shanghai 201206, China
 Tel: +86 21 2892 9499



The distinctive diamond shape cast into every spring case uniquely identifies the regulator as part of the Fisher® brand and assures you of the highest-quality engineering, durability, performance, and support.

For further information visit www.fisherregulators.com

The Emerson logo is a trademark and service mark of Emerson Electric Co. All other marks are the property of their prospective owners. Fisher is a mark owned by Fisher Controls International LLC, a business of Emerson Process Management.

The contents of this publication are presented for informational purposes only, and while every effort has been made to ensure their accuracy, they are not to be construed as warranties or guarantees, express or implied, regarding the products or services described herein or their use or applicability. We reserve the right to modify or improve the designs or specifications of such products at any time without notice.

Emerson Process Management Regulator Technologies, Inc. does not assume responsibility for the selection, use or maintenance of any product. Responsibility for proper selection, use and maintenance of any Emerson Process Management Regulator Technologies, Inc. product remains solely with the purchaser.