

# MR98 Series Backpressure Regulators, Relief and Differential Relief Valves

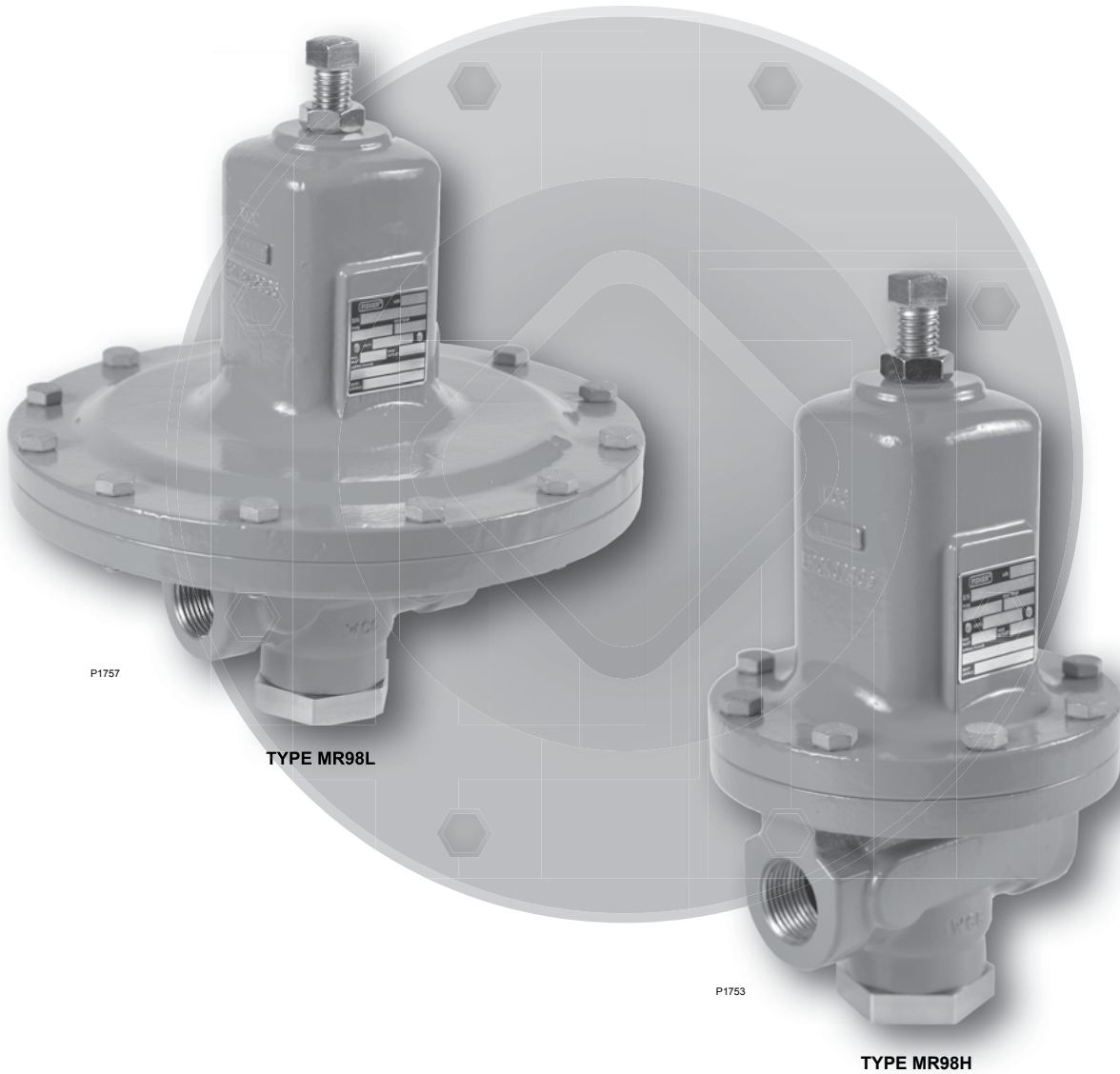

*Figure 1. Typical MR98 Series Backpressure Regulators, Relief and Differential Relief Valves*

# MR98 Series

## Specifications

This section lists the specifications for the MR98 Series regulators. Factory specification such as type, maximum inlet pressure, maximum temperature, maximum outlet pressure, spring range, orifice size and seat material are stamped on the nameplate fastened on the regulator at the factory.

### Available Constructions

**Type MR98L:** Direct-operated low pressure backpressure regulator/relief valve with 2 to 38 psig / 0.14 to 2.6 bar set pressure range

**Type MR98H:** Direct-operated high pressure backpressure regulator/relief valve with 5 to 200 psig / 0.34 to 13.8 bar set pressure range

**Type MR98HH:** Direct-operated high pressure backpressure/relief valve with 150 to 375 psig / 10.3 to 25.9 bar set pressure range

**Type MR98LD:** Pressure-loaded low pressure differential pressure relief valve with 2 to 38 psi / 0.14 to 2.6 bar set pressure range

**Type MR98HD:** Pressure-loaded high pressure differential pressure relief valve with 5 to 200 psi / 0.34 to 13.8 bar set pressure range

**Type MR98HHD:** Pressure-operated high pressure backpressure/relief valve with 150 to 375 psi / 10.3 to 25.9 bar differential set pressure range

### Body and Orifice Sizes

**1/4 NPT:** 0.284 in. / 7.22 mm

**1/2 in. / DN 15:** 0.416 in. / 10.56 mm

**3/4 and 1 in. / DN 20 and 25:**  
0.631 in. / 16.02 mm

**1-1/2 and 2 in. / DN 40 and 50:**  
1.142 in. / 29 mm

### Maximum Spring Case Loading Pressure for Types MR98LD, MR98HD and MR98HHD (Spring Setting Plus Loading Pressure)<sup>(1)(2)</sup>

#### Type MR98LD Spring Case

*Gray Cast Iron:* 50 psig / 3.4 bar

*Steel or Stainless steel:* 125 psig / 8.6 bar

#### Type MR98HD Spring Case

*Gray Cast Iron:* 250 psig / 17.2 bar

*Steel or Stainless steel:* 300 psig / 20.7 bar

#### Type MR98HHD Spring Case

*Steel or Stainless steel:* 300 psig / 20.7 bar

### Maximum Inlet and Outlet Pressure Rating

See Table 4

### Body Sizes and End Connection Styles

See Tables 1 and 2

### Maximum Cold Working Pressures of Body Size and Materials<sup>(1)(2)</sup>

See Table 4

### Flow Coefficients

BODY SIZE		C <sub>v</sub>	C <sub>g</sub>	C <sub>i</sub>
In.	DN			
1/4 NPT	----	1.4	48	34.3
1/2	15	3.4	120	35.3
3/4 and 1	20 and 25	6.5	250	38.5
1-1/2 and 2	40 and 50	20.0	780	39.0

### IEC Sizing Coefficients

BODY SIZE		X <sub>T</sub>	F <sub>d</sub>	F <sub>L</sub>	K <sub>m</sub>
In.	DN				
1/4 NPT	----	0.743	0.74	0.95	0.90
1/2	15	0.787	0.78	0.94	0.88
3/4 and 1	20 and 25	0.935	0.70	0.91	0.83
1-1/2 and 2	40 and 50	0.961	0.69	0.94	0.88

### Set Pressure Ranges

See Table 3

### Pressure Registration

Internal or External

### Shutoff Classification Per ANSI/FCI 70-3-2004

**Metal Seats:** Class IV

**Polytetrafluoroethylene (PTFE):** Class IV

**Elastomer Seats:** Class VI or better

### Temperature Capabilities for Elastomer Parts<sup>(1)(3)</sup>

See Table 5

### Temperature Capabilities for Metal Parts<sup>(1)(3)</sup>

See Table 5

### Approximate Weights

#### MR98H Series:

*1/4 NPT:* 5 lbs / 2.3 kg

*1/2 in. / DN 15:* 10 lbs / 4.5 kg

*3/4 and 1 in. / DN 20 and 25:* 22 lbs / 10 kg

*1-1/2 and 2 in. / DN 40 and 50:* 55 lbs / 25 kg

#### MR98L Series:

*1/4 NPT:* 7 lbs / 3.2 kg

*1/2 in. / DN 15:* 15 lbs / 6.8 kg

*3/4 and 1 in. / DN 20 and 25:* 35 lbs / 16 kg

1. The pressure/temperature limits in this Instruction Manual and any applicable standard limitation should not be exceeded.

2. Temperature and/or the body end connection may decrease these maximum pressures.

3. Pressure and/or the body end connection may decrease these maximum temperatures.



## WARNING

Failure to follow these instructions or to properly install and maintain this equipment could result in an explosion, fire and/or chemical contamination causing property damage and personal injury or death.

Fisher® backpressure regulators, relief and differential relief valves must be installed, operated and maintained in accordance with federal, state and local codes, rules and regulations and Emerson Process Management Regulator Technologies, Inc. (Emerson™) instructions.

If a leak develops or if the outlet continually vents gas, service to the unit may be required. Failure to correct trouble could result in a hazardous condition. Only a qualified person shall install or service the unit.

Installation, operation and maintenance procedures performed by unqualified person may result in improper adjustment and unsafe operation. Either condition may result in equipment damage or personal injury. Call a qualified person when installing, operating and maintaining the MR98 Series backpressure regulators, relief and differential relief valves.

## Introduction

### Scope of the Manual

This manual provides instructions for the installation, adjustment, maintenance and parts ordering information of MR98 Series backpressure regulators, relief and differential relief valves. Instructions and parts lists for other equipment mentioned in this Instruction Manual are found in separate manuals.

## Product Description

The MR98 Series backpressure regulator, relief and differential relieve valve are suitable for liquid, gas, air and steam service. Typical applications include use in wash tanks, small heaters, fuel and oil lines, air supply systems, test fixtures and sterilizers.

**Type MR98L**—Direct-operated, backpressure regulator or relief valve with relief set pressure range from 2 to 38 psig / 0.14 to 2.6 bar in four ranges. Body sizes are available from 1/4 NPT to 1 in. / DN 25.

**Type MR98H**—Basically the same as the Type MR98L but permits higher relief set pressure ranges from 5 to 200 psig / 0.34 to 13.8 bar, in four ranges. Body sizes are available from 1/4 NPT to 2 in. / DN 50.

**Type MR98HH**—Provides relief with higher set pressure range from 150 to 375 psig / 10.3 to 25.9 bar. Body sizes are available in 1/4 NPT to 1 in. / DN 25 sizes.

**Type MR98LD**—Differential pressure relief valve with set pressure range from 2 to 38 psig / 0.14 to 2.6 bar. Body sizes are available from 1/4 NPT to 1 in. / DN 25.

**Type MR98HD**—Basically the same as Type MR98LD but permits higher differential relief set pressure from 5 to 200 psig / 0.34 to 13.8 bar. Body sizes are available from 1/4 NPT to 2 in. / DN 50.

**Type MR98HHD**—Differential pressure relief valve with higher set pressure range from 150 to 375 psi / 10.3 to 25.9 bar. Bodies are available in 1/4 NPT to 1 in. / DN 25 sizes.

# MR98 Series

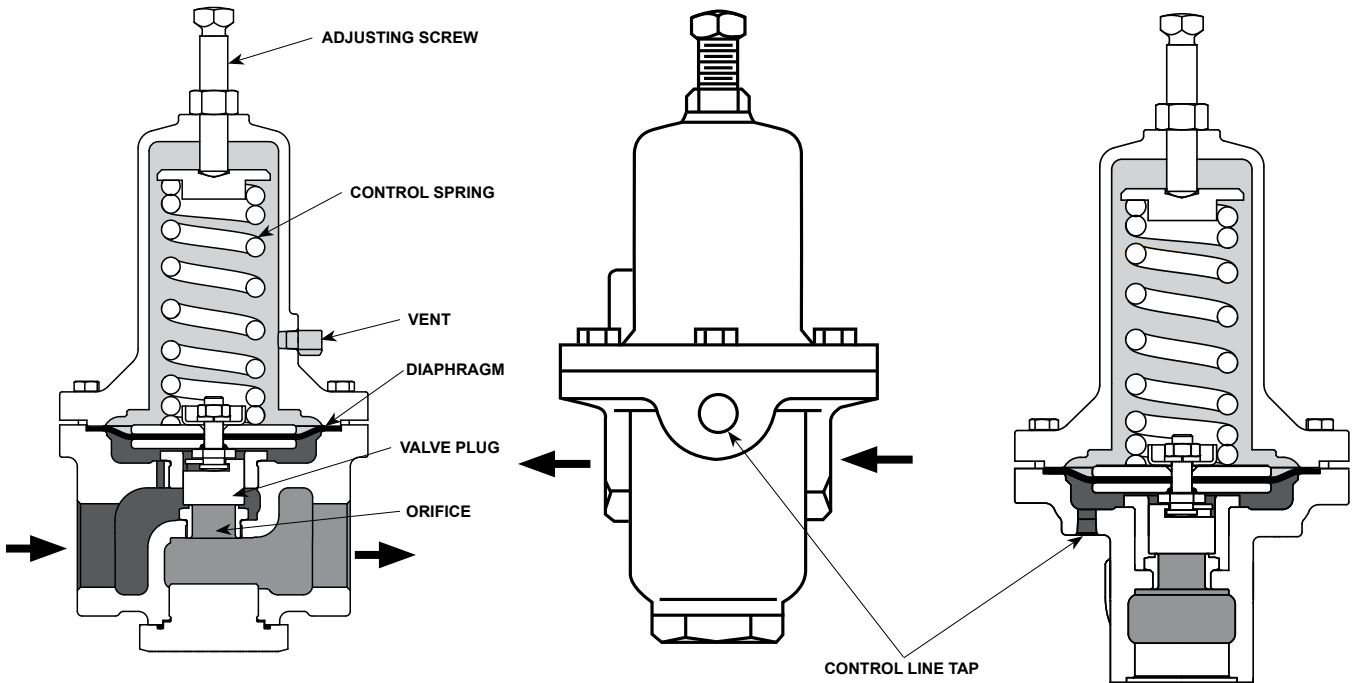

TYPE MR98H WITH INTERNAL PRESSURE REGISTRATION

BACK VIEW OF 1/2 IN. / DN 15 TYPE MR98H WITH EXTERNAL PRESSURE REGISTRATION

SIDE AND INTERNAL VIEW OF 3/4 TO 2 IN. / DN 20 TO 50 TYPE MR98H WITH EXTERNAL PRESSURE REGISTRATION (ALSO TYPICAL OF TYPE MR98L, 1/2 TO 2 IN. / DN 15 TO 50 BODIES)

- INLET PRESSURE
- OUTLET PRESSURE
- ATMOSPHERIC PRESSURE

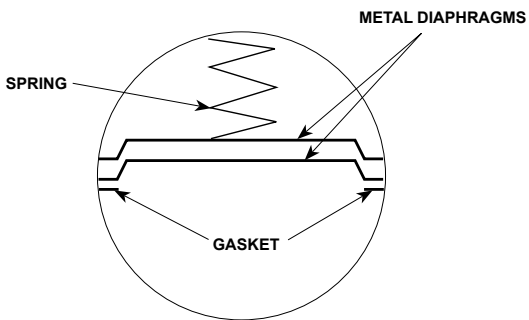

FOR TYPE MR98H WITH TWO METAL DIAPHRAGMS (ALSO TYPICAL OF TYPES MR98HH AND MR98L EXCEPT FOR TYPE MR98L, 1/4 NPT BODY, 2 TO 7 psi / 0.1 TO 0.48 bar RANGE)

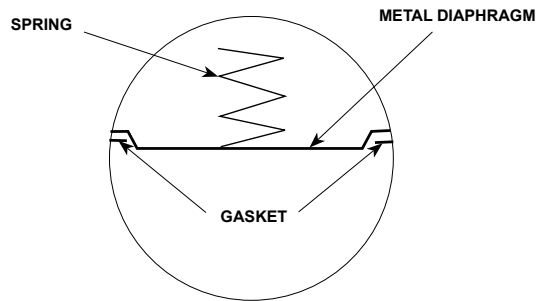

TYPE MR98L (1/4 NPT BODY, 2 TO 7 psi / 0.14 TO 0.48 bar RANGE) WITH ONE METAL DIAPHRAGM

Figure 2. MR98 Series Operational Schematics

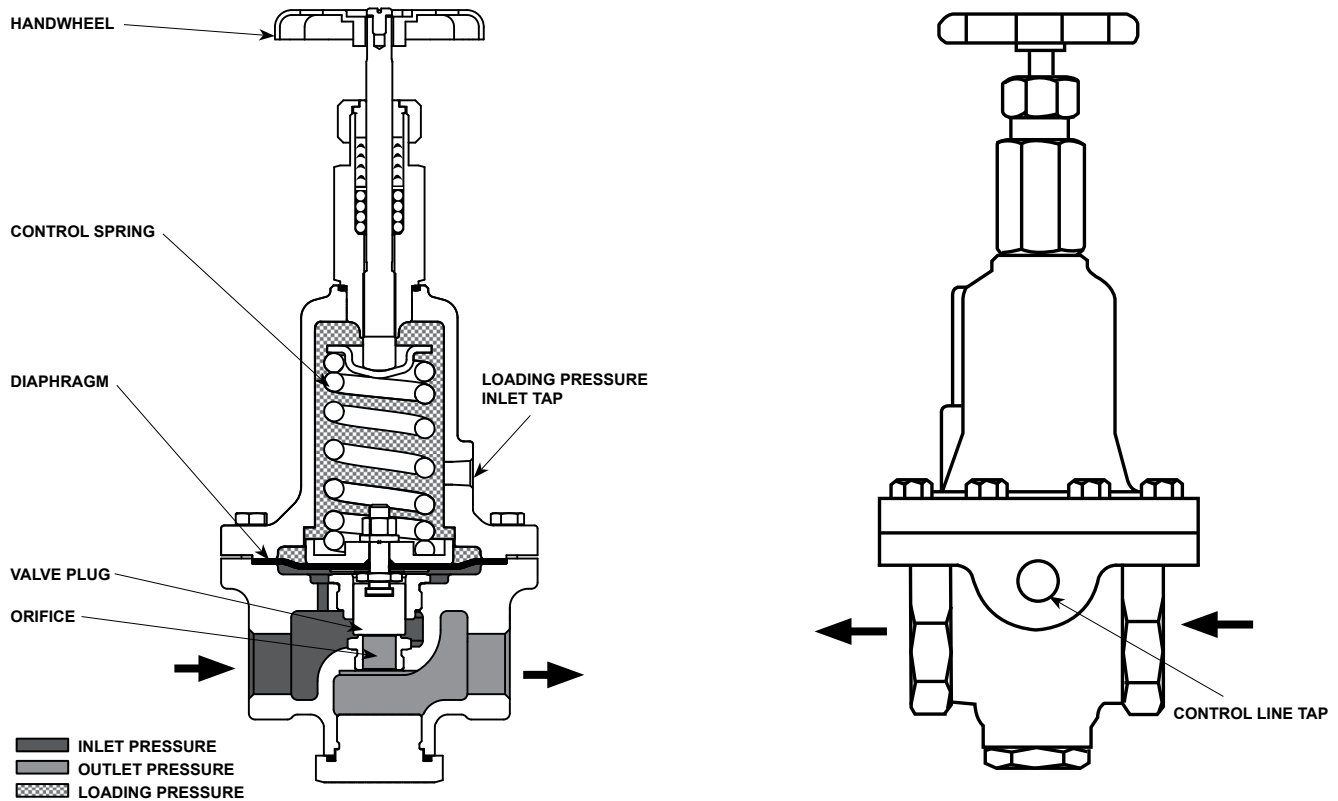

TYPE MR98HD WITH INTERNAL PRESSURE REGISTRATION

TYPE MR98HD WITH EXTERNAL PRESSURE REGISTRATION

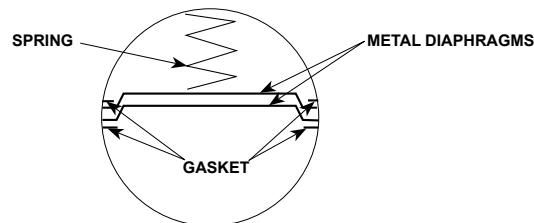

FOR TYPES MR98HD, MR98HHD AND MR98LD WITH TWO METAL DIAPHRAGMS, ASSEMBLE DIAPHRAGM GASKETS UNDER AND ABOVE THE METAL DIAPHRAGMS AS SHOWN ABOVE

Figure 2. MR98 Series Operational Schematics (continued)

## Principle of Operation

Relief or backpressure valves respond to changes in upstream pressure. Pressure changes register under the diaphragm (see Figure 2) through a registration hole in the valve body or through an external control line. When the pressure increases above the spring setting, the pressure underneath the diaphragm overcomes the spring compression. This causes the valve plug to move away from the orifice. The flow path through the valve is open and excess pressure is vented. When upstream pressure drops below setpoint, the valve closes.



Differential relief valves are used to maintain a differential pressure between the controlled pressure and loading pressure of a system. The spring setting determines the differential.

The differential relief valve responds to both controlled pressure and loading pressure and opens or closes as these pressures change. If the loading pressure increases, pressure on the upper side of the diaphragm increases. The valve plug moves closer to the orifice and restricts the flow through the relief valve. When loading pressure decreases, pressure on the upper side of the diaphragm decreases. This allows the valve plug to move away from the orifice and allow more flow through the differential relief valve (to atmosphere or back into the system). The differential relief valve opens and closes in response to changes in the controlled pressure. In this way, the differential pressure between the controlled and uncontrolled pressures is maintained.

# MR98 Series

**Table 1. Types MR98L and MR98LD Regulators Body Constructions**

BODY SIZE	BODY CONSTRUCTION	END CONNECTION STYLE	BODY MATERIAL				
			Gray Cast Iron	WCC or LCC Steel	CF8M Stainless Steel <sup>(1)</sup>	CF3M Stainless Steel <sup>(1)</sup>	Monel <sup>®</sup> or Hastelloy <sup>®</sup> C <sup>(1)</sup>
1/4 in.	Without Control Line and Gauge Port	NPT					
1/2 in. / DN 15	Without Control Line and Gauge Port	NPT					
		SWE					
		Welded CL150 RF					
		Welded CL300 RF					
		Welded PN 16/25/40 RF					
3/4 in. / DN 20	Without Control Line and Gauge Port	With Control Line but Without Gauge Port	NPT				
		NPT					
		SWE					
		Welded CL150 RF					
		Welded CL300 RF					
	Welded PN 16/25/40 RF						
	With Gauge Port but Without Control Line	With Control Line but Without Gauge Port	NPT				
		NPT					
		Welded CL150 RF					
		Welded CL300 RF					
Welded PN 16/25/40 RF							
1 in. / DN 25	Without Control Line and Gauge Port	Without Control Line and Gauge Port	NPT				
		SWE					
		Welded CL150 RF					
		Welded CL300 RF					
		Welded PN 16/25/40 RF					
	With Gauge Port but Without Control Line	With Control Line but Without Gauge Port	NPT				
		NPT					
		Welded CL150 RF					
		Welded PN 16/25/40 RF					

 - Shaded areas indicate that the construction is available.  
 - Blank areas indicate that you need to contact your local Sales Office for the availability of the constructions.  
 1. Meets the chemical and physical requirements of NACE MR0175-2002 and NACE MR0103.

Monel<sup>®</sup> is a mark owned by Special Metals Corporation.  
 Hastelloy<sup>®</sup> C is a mark owned by Haynes International, Inc.

# MR98 Series

**Table 2. Types MR98H, MR98HD, MR98HH and MR98HHD Regulators Body Constructions**

BODY SIZE	BODY CONSTRUCTION	END CONNECTION STYLE	BODY MATERIAL					
			Gray Cast Iron <sup>(2)</sup>	WCC or LCC Steel	CF8M Stainless Steel <sup>(1)</sup>	CF3M Stainless Steel <sup>(1)</sup>	Monel <sup>®</sup> or Hastelloy <sup>®</sup> C <sup>(1)</sup>	Aluminum-Bronze
1/4 in.	Without Control Line and Gauge Port	NPT						
1/2 in. / DN 15	Without Control Line and Gauge Port	NPT						
		SWE						
		Welded CL150 RF						
		Welded CL300 RF						
		Welded PN 16/25/40 RF						
		Integral CL150 RF						
		Integral CL300 RF						
		Integral PN 16/25/40 RF						
	With Control Line but Without Gauge Port	NPT						
		Welded CL150RF						
Welded CL300RF								
3/4 in. / DN 20	Without Control Line and Gauge Port	NPT						
		SWE						
		Welded CL150 RF						
		Welded CL300 RF						
		Welded PN 16/25/40 RF						
	With Control Line but Without Gauge Port	NPT						
		Welded CL150 RF						
		Welded CL300 RF						
	With Gauge Port but Without Control Line	NPT						
		Welded CL150 RF						
Welded CL300 RF								
Welded PN 16/25/40 RF								
1 in. / DN 25	Without Control Line and Gauge Port	NPT						
		SWE						
		Welded CL150 RF						
		Welded CL300 RF						
		Welded PN 16/25/40 RF						
		Integral CL150 RF						
		Integral CL300 RF						
		Integral PN 16/25/40 RF						
	With Control Line but Without Gauge Port	NPT						
		Welded CL150 RF						
		Welded CL300 RF						
	With Gauge Port but Without Control Line	NPT						
		Welded CL150 RF						
		Welded CL300 RF						
		Welded PN 16/25/40 RF						



- Shaded areas indicate that the construction is available.  
 - Blank areas indicate that you need to contact your local Sales Office for the availability of the constructions.  
 1. Meets the chemical and physical requirements of NACE MR0175-2002 and NACE MR0103.  
 2. Available for Types MR98H and MR98HD only.

- continued -

# MR98 Series

**Table 2. Types MR98H, MR98HD, MR98HH and MR98HHD Regulators Body Constructions (continued)**

BODY SIZE	BODY CONSTRUCTION	END CONNECTION STYLE	BODY MATERIAL					
			Gray Cast Iron	WCC or LCC Steel	CF8M Stainless Steel <sup>(1)</sup>	CF3M Stainless Steel <sup>(1)</sup>	Monel <sup>®</sup> or Hastelloy <sup>®</sup> C <sup>(1)</sup>	Aluminum-Bronze
1-1/2 in. / DN 40 Types MR98H and MR98HD only	Without Control Line and Gauge Port	NPT						
		SWE						
		Welded CL150 RF						
		Welded CL300 RF						
		Welded PN 16/25/40 RF						
	With Control Line but Without Gauge Port	NPT						
		Welded CL150 RF						
		Welded CL300 RF						
	With Gauge Port but Without Control Line	NPT						
		Welded CL150 RF						
		Welded CL300 RF						
		Welded PN 16/25/40 RF						
2 in. / DN 50 Types MR98H and MR98HD only	Without Control Line and Gauge Port	NPT						
		SWE						
		Welded CL150RF						
		Welded CL300RF						
		Welded PN 16/25/40 RF						
		Integral CL150 RF						
		Integral CL300 RF						
	Integral PN 16/25/40 RF							
	With Control Line but Without Gauge Port	NPT						
		Welded CL150 RF						
		Welded CL300 RF						
	With Gauge Port but Without Control Line	NPT						
		Welded CL150 RF						
		Welded CL300 RF						
		Welded PN 16/25/40 RF						

 - Shaded areas indicate that the construction is available.  
 - Blank areas indicate that you need to contact your local Sales Office for the availability of the constructions.  
 1. Meets the chemical and physical requirements of NACE MR0175-2002 and NACE MR0103.

Monel<sup>®</sup> is a mark owned by Special Metals Corporation.  
 Hastelloy<sup>®</sup> C is a mark owned by Haynes International, Inc.



# MR98 Series

**Table 3. MR98 Series Body Sizes, Pressure Ranges and Spring Information**

TYPE	BODY SIZE		CONTROL PRESSURE RANGE <sup>(1)</sup>		SPRING WIRE DIAMETER		SPRING FREE LENGTH		SPRING MATERIAL	SPRING PART NUMBER	SPRING COLOR
	In.	DN	psig	bar	In.	mm	In.	mm			
MR98L and MR98LD	1/4	----	2 to 7	0.14 to 0.48	0.148	3.76	2.00	50.8	Zinc-plated steel	1E392527022	Yellow
			6 to 14	0.41 to 0.97	0.170	4.32	2.00	50.8	Zinc-plated steel	ERAA01888A0	Green
			12 to 25	0.83 to 1.7	0.207	5.26	1.938	49.2	Powder-coated steel	ERAA01889A0	Red
			20 to 38	1.4 to 2.6	0.225	5.72	2.086	53.0	Powder-coated steel	ERAA01929A0	Blue
	1/2	15	2 to 7	0.14 to 0.48	0.207	5.26	2.50	63.5	Powder-coated steel	ERCA04288A0	Yellow
			6 to 14	0.41 to 0.97	0.234	5.94	2.595	65.9	Powder-coated steel	ERAA01910A0	Green
			12 to 25	0.83 to 1.7	0.283	7.19	2.44	62.0	Powder-coated steel	ERAA01911A0	Red
			20 to 38	1.4 to 2.6	0.331	8.41	2.250	57.2	Powder-coated steel	ERAA02889A0	Blue
	3/4 and 1	20 and 25	2 to 7	0.14 to 0.48	0.306	7.77	4.00	102	Powder-coated steel	1E398927022	Yellow
			6 to 14	0.41 to 0.97	0.343	8.71	4.00	102	Powder-coated steel	1E399027142	Green
			12 to 25	0.83 to 1.7	0.406	10.3	4.00	102	Powder-coated steel	1E399127162	Red
			20 to 38	1.4 to 2.6	0.468	11.9	3.75	95.3	Powder-coated steel	1L380127082	Blue
3/4 and 1	20 and 25	2 to 7	0.14 to 0.48	0.306	7.77	4.00	102	Powder-coated stainless steel	1E3989X0052	Yellow	
		6 to 14	0.41 to 0.97	0.375	9.53	3.88	98.6	Stainless steel	1K762537022	Unpainted	
		12 to 25	0.83 to 1.7	0.437	11.1	4.00	102	Stainless steel	11A8269X012	Unpainted	
MR98H and MR98HD	1/4	----	15 to 35	1.0 to 2.4	0.148	3.76	2.00	50.8	Zinc-plated steel	1E392527022	Yellow
			25 to 75	1.7 to 5.2	0.170	4.32	2.00	50.8	Zinc-plated steel	ERAA01888A0	Green
			70 to 140	4.8 to 9.7	0.207	5.26	1.938	49.2	Powder-coated steel	ERAA01889A0	Red
			130 to 200	9.0 to 13.8	0.225	5.72	2.086	53.0	Powder-coated steel	ERAA01929A0	Blue
	1/2	15	15 to 35	1.0 to 2.4	0.207	5.26	2.50	63.5	Powder-coated steel	ERCA04288A0	Yellow
			25 to 75	1.7 to 5.2	0.234	5.94	2.595	65.9	Powder-coated steel	ERAA01910A0	Green
			70 to 140	4.8 to 9.7	0.283	7.19	2.44	62.0	Powder-coated steel	ERAA01911A0	Red
			130 to 200	9.0 to 13.8	0.331	8.41	2.250	57.2	Powder-coated steel	ERAA02889A0	Blue
	3/4 and 1	20 and 25	15 to 35	1.0 to 2.4	0.306	7.77	4.00	102	Powder-coated steel	1E398927022	Yellow
			25 to 75	1.7 to 5.2	0.343	8.71	4.00	102	Powder-coated steel	1E399027142	Green
			70 to 140	4.8 to 9.7	0.406	10.3	4.00	102	Powder-coated steel	1E399127162	Red
			130 to 200	9.0 to 13.8	0.468	11.9	3.75	95.3	Powder-coated steel	1L380127082	Blue
	3/4 and 1	20 and 25	15 to 35	1.0 to 2.4	0.306	7.77	4.00	102	Powder-coated stainless steel	1E3989X0052	Yellow
			25 to 75	1.7 to 5.2	0.375	9.53	3.88	98.6	Stainless steel	1K762537022	Unpainted
			70 to 140	4.8 to 9.7	0.437	11.1	4.00	102	Stainless steel	11A8269X012	Unpainted
	1-1/2 and 2	40 and 50	5 to 35	0.34 to 2.4	0.468	11.9	6.562	167	Powder-coated steel	1E792327092	Dark gray
20 to 65			1.4 to 4.5	0.500	12.7	6.50	165	Powder-coated steel	ERCA04290A0	Black with light blue stripe	
50 to 100			3.4 to 6.9	0.562	14.3	6.562	167	Powder-coated steel	ERAA01893A0	Light gray	
75 to 170			5.2 to 11.7	0.625	15.9	6.565	167	Powder-coated steel	1P7888X0022	Black	
MR98HH and MR98HHD	1/4	----	150 to 375	10.3 to 25.9	0.281	7.14	4.125	105	Powder-coated steel	1N942227142	Unpainted
	1/2	15	150 to 375	10.3 to 25.9	0.394	10.0	5.063	129	Powder-coated steel	1N943427142	Unpainted
	3/4 and 1	20 and 25	150 to 375	10.3 to 25.9	0.593	15.1	6.380	162	Chromium-silicon steel	1N9441X0022	Light gray

1. All springs may be backed off to 0 psig / 0 bar. However, highest capacities and best performances are obtained by using these springs in their recommended ranges.

# MR98 Series

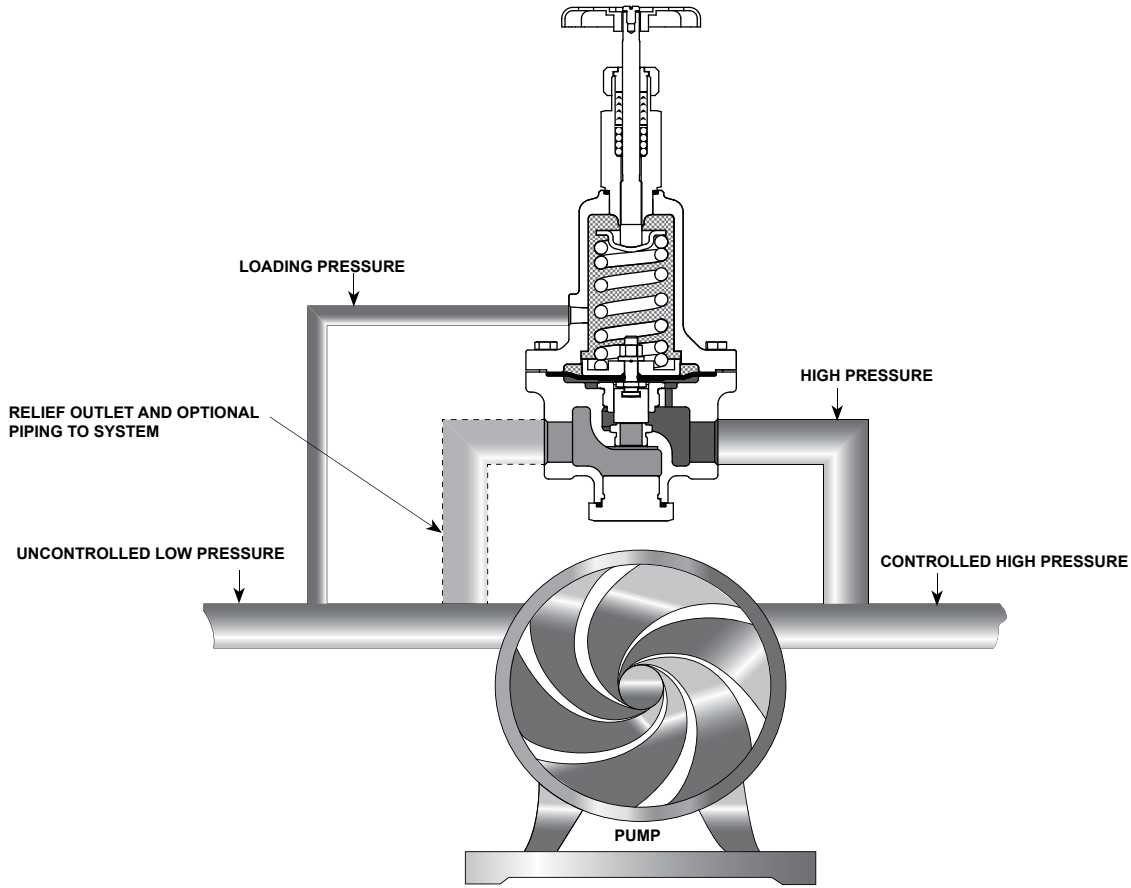

TYPE MR98HD

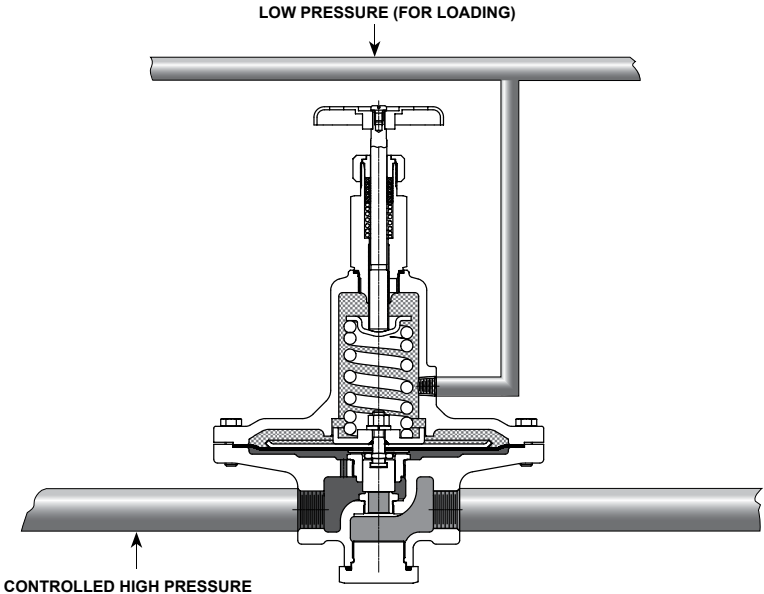

TYPE MR98LD

Figure 3. Installation Schematics for Types MR98LD and MR98HD Relief Valves

## Installation

### **WARNING**

**Personal injury or system damage may result if this backpressure regulator, relief or differential relief valve is installed where service conditions could exceed the limits given on the Specifications section and/or regulator nameplate.**

**Additionally, physical damage to the backpressure regulator or relief valve may result in personal injury or property damage due to escaping of accumulated gas. To avoid such injury and damage, install the backpressure regulator or relief valve in a safe location.**

**Under enclosed conditions or indoors, escaping gas may accumulate and be an explosion hazard. In this case, the vent should be piped outdoors.**

**For regulator constructions with a spring case vent, the vent should be kept open to permit free flow of gas to the atmosphere. Protect openings against entrance of rain, snow, insects or any other foreign material that may plug the spring case vent or vent line.**

Before installing the regulator:

- Unpack the backpressure regulator or relief valve and remove the protective shipping plugs from the end connections of the body and the pressure connection in the spring case.
- Check the backpressure regulator or relief valve and make sure it has not been damaged or collected foreign material during shipping.
- Remove any debris or dirt in the tubing and the pipeline.
- Apply pipe compound to the external pipe thread for NPT bodies or use appropriate gaskets for flanged bodies.
- Make sure gas flow through the backpressure regulator or relief valve is in the same direction as the arrow on the body.
- For a differential relief valve, the design of the valve isolates the diaphragm and pressure loading spring case from the main flow stream.

The higher pressure is measured inside the body through a registration hole on the inlet side of the body or through the external control line. If loading pressure is required, connect the loading pressure line to the 1/4 NPT connection in the spring case. If loading pressure is not required, vent this connection to the atmosphere.

## Overpressure Protection

### **WARNING**

**Overpressuring any portion of this equipment may result in equipment damage, leaks in the relief valve/ backpressure regulator or personal injury due to bursting of pressure-containing parts.**

Relief, differential relief or backpressure ranges are from 2 to 375 psig / 0.14 to 25.9 bar. The individual spring range of your valve is stamped on the nameplate.

Maximum inlet pressure depend upon body materials and temperatures. See Specifications section or the maximum inlet pressure of the valve and the maximum spring case loading pressures stamped on the nameplate of Types MR98LD, MR98HD and MR98HHD. The valve should be inspected for damage after any overpressure condition.

## Vents and Relief Valve Outlet

### **WARNING**

**If using an MR98 Series backpressure regulator, relief or differential relief valve on hazardous or flammable gas service, personal injury and property damage could occur due to fire or explosion of vented gas that may have accumulated.**

**To prevent such injury or damage, provide piping or tubing to vent the gas to a safe, well-ventilated area. All vents should be kept open to permit free flow of gas to the atmosphere. Protect openings against entrance of rain, snow, insects or any other foreign material that may plug the vent or vent line.**

# MR98 Series

**Table 4. Maximum Cold Working Pressures of Body Size and Materials<sup>(1)(2)</sup>**

REGULATOR TYPE	BODY SIZE	BODY AND SPRING CASE MATERIALS	MAXIMUM INLET PRESSURE <sup>(3)</sup>		MAXIMUM OUTLET PRESSURE		MAXIMUM SPRING CASE PRESSURE	
			psig	bar	psig	bar	psig	bar
MR98L	All Sizes	Gray Cast Iron	60	4.14	60	4.14	50	3.44
		Steel	150	10.3	150	10.3	125	8.61
		Stainless steel	150	10.3	150	10.3	125	8.61
		Monel <sup>®</sup>	150	10.3	150	10.3	125	8.61
		Hastelloy <sup>®</sup> C	150	10.3	150	10.3	125	8.61
MR98LD	All Sizes	Gray Cast Iron	60	4.14	60	4.14	50	3.44
		Steel	150	10.3	150	10.3	125	8.61
		Stainless steel	150	10.3	150	10.3	125	8.61
		Monel <sup>®</sup>	150	10.3	150	10.3	125	8.61
		Hastelloy <sup>®</sup> C	150	10.3	150	10.3	125	8.61
MR98H	All Sizes	Gray Cast Iron	300	20.7	300	20.7	250	17.2
		Steel	300	20.7	300	20.7	300	20.7
		Stainless steel	300	20.7	300	20.7	300	20.7
		Monel <sup>®</sup>	300	20.7	300	20.7	300	20.7
		Hastelloy <sup>®</sup> C	300	20.7	300	20.7	300	20.7
		Aluminum-Bronze	300	20.7	300	20.7	300	20.7
MR98HD	All Sizes	Gray Cast Iron	300	20.7	300	20.7	250	17.2
		Steel	300	20.7	300	20.7	300	20.7
		Stainless steel	300	20.7	300	20.7	300	20.7
		Monel <sup>®</sup>	300	20.7	300	20.7	300	20.7
		Hastelloy <sup>®</sup> C	300	20.7	300	20.7	300	20.7
		Aluminum-Bronze	300	20.7	300	20.7	300	20.7
MR98HH	All Sizes	Steel	400	27.6	400	27.6	300	20.7
		Stainless steel	400	27.6	400	27.6	300	20.7
		Monel <sup>®</sup>	400	27.6	400	27.6	300	20.7
		Hastelloy <sup>®</sup> C	400	27.6	400	27.6	300	20.7
		Aluminum-Bronze	400	27.6	400	27.6	300	20.7
MR98HHD	All Sizes	Steel	400	27.6	400	27.6	300	20.7
		Stainless steel	400	27.6	400	27.6	300	20.7
		Monel <sup>®</sup>	400	27.6	400	27.6	300	20.7
		Hastelloy <sup>®</sup> C	400	27.6	400	27.6	300	20.7
		Aluminum-Bronze	400	27.6	400	27.6	300	20.7

1. The pressure/temperature limits in this Instruction Manual and any applicable standard limitation should not be exceeded.
2. Temperature, trim material and/or the body end connection may decrease these maximum pressures.
3. Maximum inlet pressure equals set pressure plus build-up.

**Table 5. Temperature Capabilities<sup>(1)(2)</sup>**

MATERIAL	TEMPERATURE RANGE
Elastomer Part	
Nitrile (NBR)	-40 to 180°F / -40 to 82°C
Neoprene (CR)	-40 to 180°F / -40 to 82°C
Fluorocarbon (FKM)	0 to 300°F / -18 to 149°C, Limited to 200°F / 93°C for hot water
Ethylenepropylene (EPDM)	20 to 275°F / -7 to 135°C
Perfluoroelastomer (FFKM)	0 to 425°F / -18 to 218°C
PTFE Diaphragm protector	-40 to 400°F / -40 to 204°C
Body Material	
Gray Cast iron	-20 to 406°F / -29 to 208°C
WCC Steel <sup>(3)</sup>	-20 to 450°F / -29 to 232°C
LCC Steel <sup>(3)</sup>	-40 to 450°F / -40 to 232°C
Stainless steel <sup>(3)</sup> , Monel <sup>®</sup> or Hastelloy <sup>®</sup> C	-40 to 450°F / -40 to 232°C

1. The pressure/temperature limits in this Instruction Manual and any applicable standard limitation should not be exceeded.
2. Pressure and/or the body end connection may decrease these maximum temperatures.
3. Meets API 614 requirements (with stainless steel trim).

**Table 6. Torque Specifications**

BODY SIZE		SPRING CASE BOLTS <sup>(1)</sup>		ORIFICE		VALVE PLUG GUIDE		BOTTOM PLUG	
In.	DN	Ft-Lbs	N•m	Ft-Lbs	N•m	Ft-Lbs	N•m	Ft-Lbs	N•m
1/4	----	6 to 8	8 to 11	6 to 8	8 to 11	40 to 50	53 to 68	50 to 58	68 to 79
1/2	15	10 to 13	13 to 18	34 to 38	46 to 51	70 to 90	94 to 122	75 to 90	102 to 122
3/4 and 1	20 and 25	24 to 30	33 to 41	50 to 60	68 to 81	85 to 100	115 to 136	100 to 125	136 to 169
1-1/2 and 2	40 and 50	40 to 50	54 to 68	180 to 200	244 to 271	125 to 150	169 to 203	170 to 200	230 to 271

1. Reduce spring case bolt's torque by 30% when using Ethylenepropylene (EPDM) diaphragms.

Hastelloy<sup>®</sup> C is a mark owned by Haynes International, Inc.  
 Monel<sup>®</sup> is a mark owned by Special Metals Corporation.

If remote venting is necessary, an optional tapped vent in the spring case is available. Install remote vent lines in the spring case and outlet openings. The vent lines must have the largest practical diameter and be as short as possible with a minimum number of bends or elbows. Install the vent line according to applicable federal, state and local codes and regulations.

## Startup

### Note

**The Specifications section and Table 4 show the maximum inlet and the differential pressures for specific constructions. Use pressure gauges to monitor inlet pressure, outlet pressure and any loading pressure during startup.**

Key numbers are shown in Figures 4 through 10.

1. Check that proper installation is completed and downstream equipment has been properly adjusted.
2. Make sure all block and vent valves are closed.
3. Decompress the control spring by turning the adjusting screw (for Types MR98L, MR98H and MR98HH) or handwheel (for Types MR98LD, MR98HD and MR98HHD) counterclockwise.
4. Slowly open the valves in the following order:
  - a. Loading supply and control line valve(s), if used
  - b. Inlet block valve
  - c. Outlet block valve
5. Set the regulator to the desired set pressure according to the Adjustment procedure.

## Adjustment

Each unit is factory set for the pressure setting specified on the order or at the mid-point of the spring range. The allowable spring range is stamped on the nameplate. If a pressure setting beyond the indicated range is required, replace with the appropriate spring. Be sure to label the regulator/valve to indicate the new pressure range.

Always use a pressure gauge to monitor pressure when making adjustments.

All MR98 Series regulator springs can be backed off to zero pressure. Recommended set pressure ranges available, maximum inlet pressures and temperatures and color codes of the respective springs are shown in the Specifications section and Table 3.

## Types MR98L, MR98H and MR98HH

1. Loosen the jam nut (key 17, Figures 4, 6, 7 and 10).
2. To increase the set pressure or pressure setting, turn the adjusting screw (key 15) clockwise. Turn the adjusting screw counterclockwise to decrease the set pressure or pressure setting.
3. Tighten the jam nut (key 17).

## Types MR98LD, MR98HD and MR98HHD

Turn the handwheel (key 38, Figures 5, 8 and 9) clockwise to increase differential pressure setting. Turn the handwheel counterclockwise to decrease the differential pressure setting.

## Shutdown

### Relief Valve

1. Close the upstream shutoff valve to the regulator inlet.
2. Close the downstream shutoff valve to the regulator outlet.
3. Slowly open the downstream vent valve to vent downstream pressure.
4. Leave the downstream vent valve open to vent inlet pressure and to release all remaining pressure in the regulator by opening the upstream vent valve or by turning the adjusting screw fully counterclockwise.

### Differential Valve (Pressure-Loaded System)

1. Close the upstream shutoff valve to the regulator inlet.
2. Close the downstream shutoff valve to the regulator outlet.



## WARNING

**To avoid damage of internal parts from a pressure-loaded actuator, carefully vent the regulator spring case pressure prior to inlet pressure.**

3. Vent the loading pressure slowly to release pressure in the spring case.

# MR98 Series

**Table 7. Number of Diaphragms Required**

BODY SIZE	TYPE	SPRING RANGE	DIAPHRAGM MATERIAL	NUMBER OF DIAPHRAGM
1/4 NPT	MR98L and MR98LD	All	Neoprene (CR)	1
			Fluorocarbon (FKM)	2
		2 to 7 psi / 0.1 to 0.5 bar	Ethylene propylene (EPDM)	2
		All except 2 to 7 psi / 0.1 to 0.5 bar	Metal	1
	MR98H, MR98HH, MR98HD and MR98HHD	All	Metal	2
			Neoprene (CR)	1
		Fluorocarbon (FKM)	2	
		Ethylene propylene (EPDM)	2	
1/2 to 2 in. / DN 15 to 50	All	All	Metal	2
			Neoprene (CR)	1
			Fluorocarbon (FKM)	2
			Ethylene propylene (EPDM)	2

- Slowly open the downstream vent valve to vent downstream pressure.
- Leave the downstream vent valve open to vent inlet pressure and to release all remaining pressure in the regulator by opening the upstream vent valve or by turning the adjusting screw fully counterclockwise.

## Backpressure Regulator

- Close the upstream shutoff valve to the regulator inlet.
- Close the downstream shutoff valve to the regulator outlet.
- To avoid internal damage due to reverse pressurization of main valve components, bleed backpressure regulator inlet pressure first before bleeding outlet pressure.

## Maintenance



### WARNING

**To avoid personal injury, property damage or equipment damage caused by sudden release of pressure or explosion of accumulated gas, do not attempt any maintenance or disassembly without first isolating the relief valve or regulator from system pressure and relieving all internal pressure from the relief valve or regulator.**

**To avoid possible personal injury from spring or pressure-loaded actuator, make sure that the adjusting screw is completely backed off or the spring case pressure is vented prior to disassembly.**

**Otherwise, the spring load or loading pressure could forcefully eject the spring case.**

**Relief valves or regulators that have been disassembled for repair must be tested for proper operation before being returned to service. Only parts manufactured by Emerson™ should be used for repairing Fisher® relief valves and regulators.**

**Due to normal wear or damage that may occur from external sources, this relief valve or backpressure regulator should be inspected and maintained periodically. The frequency of inspection and replacement of parts depends upon the severity of service conditions or the requirement of local, state and federal rules and regulations.**

Due to normal wear and damage that may occur from external sources, relief valve parts such as the O-rings, gaskets, diaphragm, orifice and valve plug should be inspected periodically and replaced as necessary. The frequency of inspection and replacement depends upon the severity of service conditions or the requirements of state and federal laws.

Instructions are given below for disassembly of the MR98 Series. These valves do not have to be removed from the pipeline to inspect internal parts. Suitable lubricants are indicated on the assembly drawings. Apply the recommended lubricants as the relief valve is being reassembled. Refer to Figures 4 to 10 while servicing the relief valve.

## Flange Cap Screw Torque Inspection

Retorquing of spring case cap screws may be necessary for some MR98 Series regulators after a period of use. Retorque the cap screws as follows:

1. Shut down the relief valve or backpressure regulator. Refer to Shutdown section for the proper procedure.
2. Retighten the cap screws (key 16) in a crisscross pattern. See Table 6 for proper torque values.
3. Follow the Startup section to repressurize the relief valve or backpressure regulator.
4. Refer to the Disassembly to Replace Diaphragm and Seats section as needed.

## Disassembly to Replace Diaphragm and Seats



**Metal diaphragms have thin sharp edges. To avoid hand cuts, be careful when handling the diaphragm, particularly the diaphragm edge.**

If the relief valve is leaking, the diaphragm may be ruptured or the seating surfaces nicked or scratched. Proceed as follows to inspect or replace the diaphragm, orifice and valve plug.

1. Shut down the backpressure regulator or relief valve. Refer to Shutdown section for the proper procedure.
2. **For Types MR98LD, MR98HD and MR98HHD:** Release all spring compression by turning the adjusting screw or handwheel (key 33 or 38) counterclockwise until it turns freely without resistance from the spring.  
**For Types MR98L, MR98H and MR98HH:** Relieve the spring tension by loosening the jam nut (key 17) and turning the adjusting screw (key 15) counterclockwise.
3. Remove cap screws (key 16) and lift off the spring case (key 2), upper spring seat (key 9) and relief valve spring (key 11). Lift out the diaphragm unit which includes the lock nut (key 31), lock washer (key 28), pusher post (key 10), gasket (key 29), lower spring seat (key 8), diaphragm (key 12), diaphragm head (key 21 for Types MR98L and MR98LD, all body sizes and for Types MR98H and MR98HD, 1-1/2 and 2 in. / DN 40 and 50 body sizes), valve plug (key 4) and Type MR98HD has another washer (key 58) and an O-ring (key 45).
4. Check the orifice (key 3) for wear or damage. If it needs to be replaced, unscrew the valve plug guide (key 7) and then the orifice. The valve plug (key 4) can be removed by sliding it off of the pusher post (key 10).
5. Place a small amount of sealant on the threads of the orifice (key 3) and valve plug guide (key 7) and reinstall these to the body (key 1). See Table 6 for torque specifications.
6. To replace the valve plug O-ring (key 53), remove the machine screw (key 24) and O-ring retainer (key 25) from the plug. Remove and replace the O-ring.
7. Separate the remainder of the diaphragm unit parts. Take the lock nut (key 31) off of the pusher post (key 10). Slide off the lock washer (key 28), lower spring seat (key 8), diaphragm head (key 21) for Types MR98L and MR98LD, all body sizes and for Types MR98H and MR98HD, 1-1/2 and 2 in. / DN 40 and 50 body sizes), diaphragm (key 12), washer (key 58) and gasket (key 29).
8. Slip the valve plug (key 4) onto the pusher post (key 10). Place a gasket (key 29) on the shaft of the pusher post over the threaded portion until it rests on the base of the post. If elastomer diaphragm (key 12) is used, place a metal washer (key 58) on top of the gasket. For Type MR98H, 1-1/2 to 2 in. / DN 40 to 50 with metal diaphragm, place another gasket on the shaft of the pusher post until it rests on the bottom diaphragm head (key 21), see Figure 7.

### Note

**If a metal diaphragm is to be replaced by an elastomer diaphragm or an elastomer diaphragm by a metal diaphragm, a new pusher post is required. Each diaphragm material requires a different pusher post length and make sure the proper number of metal or elastomer diaphragm that will be used is followed. Refer to the Parts List section or Table 7 for the correct number of diaphragm to be used.**

9. See Figures 4 to 10. For the metal diaphragms (key 12), replace the large diaphragm gasket (key 19) on the surface of the body (key 1) that will support the diaphragms. There will be two diaphragms used per regulator, except for 1/4 NPT Types MR98L and MR98LD with 2 to 7 psi / 0.1 to 0.5 bar spring range, which use only one metal diaphragm. The raised surfaces of the metal diaphragms should be placed in the unit so that they are facing toward the assembler (toward the spring) except only when one diaphragm is being used then the raised surface should be facing down (towards the body) (see Figure 2). For elastomer diaphragms, the printed side should be facing upwards when installed.

# MR98 Series

---

10. Slip the lower spring seat (key 8) and lock washer (key 28) back onto the pusher post (key 10). Lubricate the threads of the pusher post and tighten the pusher post lock nut (key 31) until the lock washer is flat and then turn the nut an additional 1/8 to 1/4 turn. Return the diaphragm (key 12), spring seat and pusher post assembly to the body (key 1).
11. Set the relief valve spring (key 11) in the lower spring seat and place the upper spring seat (key 9) on the spring.
12. Put the spring case (key 2) over the spring (key 11) and onto the body (key 1). Tighten the cap screws (key 16) finger tight only.
13. To ensure proper slack in the diaphragm (key 12), apply some spring compression by turning the adjusting screw (key 15) or handwheel (key 38) clockwise. Finish tightening the cap screws. See Table 6 for recommended torque values.

## Replacement or Maintenance of Bottom Plug O-ring

If there is any external leakage from the bottom plug the bottom plug O-ring could be worn out or damaged. Proceed as follows to check and/or replace it.

1. Shut down the regulator. Refer to Shutdown section for the proper procedure.
2. Unscrew the bottom plug (key 5) from the body (key 1). Inspect the bottom plug seal (key 63) for damage. Replace the bottom plug seal if damage is noted. Lightly lubricate the bottom plug O-ring or graphite ring before installing it onto the bottom plug.
3. Reassemble the regulator in the reverse order of the above steps. When installing the bottom plug (key 5), coat the threads and sealing surface with anti-seize compound to ensure an adequate metal-to-metal seal. Reference Table 6 for proper torque values.

## Disassembly to Replace Packing (For Types MR98LD, MR98HD and MR98HHD)

Leakage around the adjusting screw may be caused by worn packing in the stuffing box. To check the packing, perform the following procedures.

1. Before returning the upper spring case (key 2) to the body (key 1), replace the packing (key 36) in the packing/stuffing box (key 32).

2. Take out the machine screw (key 41) and lift off the washer (key 44) and handwheel (key 38).
3. Unscrew the packing/stuffing box (key 32). Unscrew the packing/stuffing box nut (key 35) and take it and the packing follower (key 34) off of the adjusting screw (key 33).
4. Unscrew and pull the adjusting screw (key 33) out through the bottom of the packing/stuffing box (key 32).
5. Pull out the packing (key 36) and replace it. Replace the packing/stuffing box gasket (key 37).
6. Reassemble the packing/stuffing box (key 32) unit by returning the adjusting screw (key 33) to the inside of the stuffing box. Slip the packing follower (key 34) onto the adjusting screw and into the stuffing box. Screw on the packing nut (key 35). See Table 6 for torque specifications.
7. Put the packing/stuffing box (key 32) onto the spring case (key 2). Set the handwheel (key 38) and washer (key 44) on the adjusting screw (key 33) and screw in the machine screw (key 41).
8. Set the spring (key 11) and upper spring seat (key 9) over the lower spring seat (key 8). Place the spring case (key 2) on the body (key 1), tightening the cap screws (key 16) finger-tight only.
9. To ensure proper slack in the diaphragm (key 12), apply some spring compression by turning the adjusting screw (key 15) or handwheel (key 38) clockwise. Tighten the cap screws (key 16).

## Parts Ordering

When corresponding with your local Sales Office about this equipment, always reference the equipment serial number stamped on the nameplate.

When ordering replacement parts, specify the complete 11-character part number of each required part as found in the following parts list. Separate kits containing all recommended spare parts are available.

### Note

**In this parts list, parts marked NACE are intended for corrosion-resistant service as detailed in the NACE International Standard MR0175 and NACE MR0103.**

**Optional materials are available to meet ANSI/NACE MR0175/ISO 15156, please contact your local Sales Office for special ordering instructions.**



## Parts List

Key	Description	Part Number	Key	Description	Part Number
	Parts Kit (included are keys 3, 4, 12, 29, 59 and 63)		3*	Orifice (continued)	
	Types MR98H, MR98HH and MR98HD			Composition seat	
	With Stainless steel diaphragm and trim			1/4 NPT Body Size	
	1/4 NPT Body Size	RMR98HX0042		416 Stainless steel	GF05036X022
	1/2 in. / DN 15 Body Size	RMR98HX0052		316 Stainless steel, NACE, Oxygen Service	GF05036X032
	3/4 and 1 in. / DN 20 and 25 Body Sizes	RMR98HX0062		1/2 in. / DN 15 Body Size	
	1-1/2 and 2 in. / DN 40 and 50 Body Sizes	RMR98HX0082		416 Stainless steel	GF05552X022
	With Neoprene (CR) diaphragm and Nitrile (NBR)/416 Stainless steel trim			316 Stainless steel, NACE, Oxygen Service	GF05552X032
	1/4 NPT Body Size	RMR98HX0012		Hastelloy® C, NACE	GF05552X052
	1/2 in. / DN 15 Body Size	RMR98HX0022		3/4 and 1 in. / DN 20 and 25 Body Sizes	
	3/4 and 1 in. / DN 20 and 25 Body Sizes	RMR98HX0032		416 Stainless steel	GF04824X022
	1-1/2 and 2 in. / DN 40 and 50 Body Sizes	RMR98HX0072		316 Stainless steel, NACE, Oxygen Service	GF04824X032
	Types MR98L and MR98LD			Hastelloy® C, NACE	GF04824X052
	With Stainless steel diaphragm and plug			1-1/2 and 2 in. / DN 40 and 50 Body Sizes	
	1/4 NPT Body Size	RMR98LX0042		416 Stainless steel	GF05513X022
	1/2 in. / DN 15 Body Size	RMR98LX0052		316 Stainless steel, NACE, Oxygen Service	GF05513X032
	3/4 and 1 in. / DN 20 and 25 Body Sizes	RMR98LX0062		Hastelloy® C, NACE	GF05513X052
	With Neoprene (CR) and Nitrile (NBR)/Brass Disk		4*	Valve Plug	See Following Tables
	1/4 NPT Body Size	RMR98LX0012	5	Bottom Plug	
	1/2 in. / DN 15 Body Size	RMR98LX0022		1/4 NPT Body Size	
	3/4 and 1 in. / DN 20 and 25 Body Sizes	RMR98LX0032		416 Stainless steel	GF05500X022
1	Body	See Following Tables		316 Stainless steel, NACE, Oxygen Service	GF05500X032
2	Spring Case	See Following Tables		Hastelloy® C, NACE	GF05500X052
3*	Orifice			Monel®, NACE	GF05500X042
	Metal-to-metal seat			1/2 in. / DN 15 Body Size	
	1/4 NPT Body Size			416 Stainless steel	GF05532X022
	416 Stainless steel	GF04856X022		316 Stainless steel, NACE, Oxygen Service	GF05532X032
	316 Stainless steel, NACE	GF04856X032		Hastelloy® C, NACE	GF05532X052
	Hastelloy® C, NACE	GF04856X052		Monel®, NACE	GF05532X042
	Monel®, NACE	GF04856X042		3/4 and 1 in. / DN 20 and 25 Body Sizes	
	1/2 in. / DN 15 Body Size			416 Stainless steel	GF05496X022
	416 Stainless steel	GF04841X022		316 Stainless steel, NACE, Oxygen Service	GF05496X032
	316 Stainless steel, NACE	GF04841X032		Hastelloy® C, NACE	GF05496X052
	Alloy 6, NACE	GF04841X062		Monel®, NACE	GF05496X042
	Hastelloy® C, NACE	GF04841X052		1-1/2 and 2 in. / DN 40 and 50 Body Sizes	
	Monel®, NACE	GF04841X042		416 Stainless steel	GF05511X022
	3/4 and 1 in. / DN 20 and 25 Body Sizes			316 Stainless steel, NACE, Oxygen Service	GF05511X032
	416 Stainless steel	GF04821X022		Hastelloy® C, NACE	GF05511X052
	316 Stainless steel, NACE	GF04821X032		Monel®, NACE	GF05511X042
	Alloy 6, NACE	GF04821X062		7	Valve Plug Guide
	Hastelloy® C, NACE	GF04821X052		1/4 NPT Body Size	
	Monel®, NACE	GF04821X042		416 Stainless steel	GF04882X022
	1-1/2 and 2 in. / DN 40 and 50 Body Sizes			316 Stainless steel, NACE, Oxygen Service	GF04882X032
	416 Stainless steel	GF04896X022		Hastelloy® C, NACE	GF04882X052
	316 Stainless steel, NACE	GF04896X032		Monel®, NACE	GF04882X042
	Alloy 6, NACE	GF04896X062		1/2 in. / DN 15 Body Size	
	Hastelloy® C, NACE	GF04896X052		416 Stainless steel	GF05534X022
	Monel®, NACE	GF04896X042		316 Stainless steel, NACE, Oxygen Service	GF05534X032
				Hastelloy® C, NACE	GF05534X052
				Monel®, NACE	GF05534X042
				3/4 and 1 in. / DN 20 and 25 Body Sizes	
				416 Stainless steel	GF05529X022
				316 Stainless steel, NACE, Oxygen Service	GF05529X032
				Hastelloy® C, NACE	GF05529X052
				Monel®, NACE	GF05529X042

\*Recommended Spare Part  
 Monel® is a mark owned by Special Metals Corporation.  
 Hastelloy® C is a mark owned by Haynes International, Inc.

# MR98 Series

Key	Description	Part Number	Key	Description	Part Number
7	Valve Plug Guide (continued)		10	Pusher Post	
	1-1/2 and 2 in. / DN 40 and 50 Body Sizes			Composition Diaphragm	
	416 Stainless steel	GF05539X022		1/4 NPT Body Size	
	316 Stainless steel, NACE, Oxygen Service	GF05539X032		416 Stainless steel	1L345635132
	Hastelloy® C, NACE	GF05539X052		316 Stainless steel, NACE, Oxygen Service	1L345635072
	Monel®, NACE	GF05539X042		Hastelloy® C, NACE	1L3456X0032
8	Lower Spring Seat, NACE			Monel®, NACE	1L3456X0022
	Types MR98L, MR98LD, MR98H and MR98HD			1/2 in. / DN 15 Body Size	
	1/4 NPT Body Size			416 Stainless steel	ERCA01344A0
	Aluminum <sup>(1)</sup>	1L344609012		316 Stainless steel, NACE, Oxygen Service	ERCA01344A1
	Stainless steel	1L3446X0012		Hastelloy® C, NACE	ERCA01344A3
	1/2 in. / DN 15 Body Size			Monel®, NACE	ERCA01344A2
	Aluminum <sup>(1)</sup>	1L339708012		3/4 and 1 in. / DN 20 and 25 Body Sizes	
	Stainless steel	1L3397X0012		416 Stainless steel	1L343835132
	3/4 and 1 in. / DN 20 and 25 Body Sizes			316 Stainless steel, NACE, Oxygen Service	1L343835072
	Aluminum <sup>(1)</sup>	1L342708012		Hastelloy® C, NACE	1L3438X0012
	Stainless steel	1L3427X0012		Monel®, NACE	1L3438X0022
	1-1/2 and 2 in. / DN 40 and 50 Body Sizes			1-1/2 and 2 in. / DN 40 and 50 Body Sizes	
	Steel <sup>(1)</sup>	1P787724152		416 Stainless steel	1P788435132
	Stainless steel	1P7877X0012		316 Stainless steel, NACE, Oxygen Service	1P788435072
	Types MR98HH and MR98HHD			Hastelloy® C, NACE	1P7884X0012
	1/4 NPT Body Size			Monel®, NACE	1P7884X0022
	Aluminum <sup>(1)</sup>	1N942009012		Metal Diaphragm	
	Stainless steel	1N9420X0012		1/4 NPT Body Size	
	1/2 in. / DN 15 Body Size			416 Stainless steel	GF04910X022
	Aluminum <sup>(1)</sup>	1N943024272		316 Stainless steel, NACE, Oxygen Service	GF04910X032
	Stainless steel	1N9430X0012		Hastelloy® C, NACE	GF04910X052
	3/4 and 1 in. / DN 20 and 25 Body Sizes			Monel®, NACE	GF04910X042
	Steel <sup>(1)</sup>	1N943824272		1/2 in. / DN 15 Body Size	
	Stainless steel	1N9438X0012		416 Stainless steel	ERCA01343A0
9	Upper Spring Seat, NACE			316 Stainless steel, NACE, Oxygen Service	ERCA01343A1
	Types MR98L, MR98LD, MR98H and MR98HD			Hastelloy® C, NACE	ERCA01343A3
	1/4 NPT Body Size			Monel®, NACE	ERCA01343A2
	Steel <sup>(1)</sup>	ERCA00383A0		3/4 and 1 in. / DN 20 and 25 Body Sizes	
	Stainless steel	ERCA00383A1		416 Stainless steel	1L343935132
	1/2 in. / DN 15 Body Size			316 Stainless steel, NACE, Oxygen Service	1L343935072
	Steel <sup>(1)</sup>	ERCA00823A0		Hastelloy® C, NACE	1L343940152
	Stainless steel	ERCA00823A1		Monel®, NACE	1L343940032
	3/4 and 1 in. / DN 20 and 25 Body Sizes			1-1/2 and 2 in. / DN 40 and 50 Body Sizes	
	Steel <sup>(1)</sup>	1E398725072		416 Stainless steel	1P788335132
	Stainless steel	1E3987X0012		316 Stainless steel, NACE, Oxygen Service	1P788335072
	1-1/2 and 2 in. / DN 40 and 50 Body Sizes			Hastelloy® C, NACE	1P7883X0012
	Steel <sup>(1)</sup>	1P787624092		Monel®, NACE	1P7883X00A2
	Stainless steel	1P7876X0012	11	Control Spring, NACE <sup>(1)</sup>	See Table 3
	Types MR98HH and MR98HHD		12*	Diaphragm	See Following Tables
	1/4 NPT Body Size		13	Nameplate	-----
	Steel <sup>(1)</sup>	1N942124092	14	Diaphragm Protector, PTFE, NACE	
	Stainless steel	1N9421X0012		Types MR98L and MR98LD	
	1/2 in. / DN 15 Body Size			1/4 NPT Body Size	11A5132X012
	Steel <sup>(1)</sup>	ERCA00430A0		1/2 in. / DN 15 Body Size	11A5133X012
	Stainless steel	ERCA00430A1		3/4 and 1 in. / DN 20 and 25 Body Sizes	11A5137X012
	3/4 and 1 in. / DN 20 and 25 Body Sizes			Types MR98H, MR98HD, MR98HH and MR98HHD	
	Steel <sup>(1)</sup>	1N943924092		1/4 NPT Body Size	11A5135X012
	Stainless steel	1N9439X0012		1/2 in. / DN 15 Body Size	11A5136X012
				3/4 and 1 in. / DN 20 and 25 Body Sizes	11A5134X012
				1-1/2 and 2 in. / DN 40 and 50 Body Sizes	11A5527X012

\*Recommended Spare Part

1. Part meets NACE requirements only for applications in which the part is not exposed to sour gas.

Monel® is a mark owned by Special Metals Corporation.

Hastelloy® C is a mark owned by Haynes International, Inc.

# MR98 Series

Key	Description	Part Number	Key	Description	Part Number
15	Adjusting Screw, NACE <sup>(1)</sup> Square Head Adjustment 1/4 NPT Body Size 1/2 in. / DN 15 Body Size Types MR98L and MR98H Type MR98HH 3/4 and 1 in. / DN 20 and 25 Body Sizes Types MR98L and MR98H Type MR98HH 1-1/2 and 2 in. / DN 40 and 50 Body Sizes Sealed Square Head Adjustment 1/2 in. / DN 15 Body Size 3/4 and 1 in. / DN 20 and 25 Body Sizes 1-1/2 and 2 in. / DN 40 and 50 Body Sizes Stainless steel Square Head Adjustment 1/4 NPT Body Size 1/2 in. / DN 15 Body Size Types MR98L and MR98H Type MR98HH 3/4 and 1 in. / DN 20 and 25 Body Sizes Types MR98L and MR98H Type MR98HH 1-1/2 and 2 in. / DN 40 and 50 Body Sizes Handwheel 1/2 in. / DN 15 Body Size	GF05533X012 GF05553X012 ERAA02340A0 GF05543X012 ERCA01483A0 GF05522X012 GF05553X012 GF05543X012 GF05522X012 GF05533X022 GF05553X022 ERAA02340A1 GF05543X022 ERCA01483A1 GF05522X022 ERAA02331A0	17	Jam Nut, NACE <sup>(1)</sup> (continued) Stainless steel Square Head Adjustment 1/4 NPT Body Size 1/2 in. / DN 15 Body Size 3/4 and 1 in. / DN 20 and 25 Body Sizes 1-1/2 and 2 in. / DN 40 and 50 Body Sizes Sealed Square Head Adjustment 1/2 in. / DN 15 Body Size 3/4 and 1 in. / DN 20 and 25 Body Sizes 1-1/2 and 2 in. / DN 40 and 50 Body Sizes Tee Handle Adjustment 1/4 NPT Body Size 3/4 and 1 in. / DN 20 and 25 Body Sizes 1-1/2 and 2 in. / DN 40 and 50 Body Sizes Handwheel Adjustment 1/2 in. / DN 15 Body Size	ERCA00652A1 ERCA00380A1 GF05453X022 ERCA00633A1 ERCA00380A0 GF05453X012 ERCA00633A0 ERCA00380A0 ERAA01884A0
16	Cap Screws, NACE <sup>(1)</sup> Types MR98L and MR98LD 1/4 NPT Body Size Steel (10 required) Stainless steel (10 required) 1/2 in. / DN 15 Body Size Steel (10 required) Stainless steel (10 required) 3/4 and 1 in. / DN 20 and 25 Body Sizes Steel (12 required) Stainless steel (12 required) Types MR98H, MR98HD, MR98HH and MR98HHD 1/4 NPT Body Size Steel (6 required) Stainless steel (6 required) B8M Class 2 Stainless steel (6 required) 1/2 in. / DN 15 Body Size Steel (8 required) Stainless steel (8 required) 3/4 and 1 in. / DN 20 and 25 Body Sizes Steel (8 required) Stainless steel (8 required) 1-1/2 and 2 in. / DN 40 and 50 Body Sizes Steel (8 required) Stainless steel (8 required)	ERCA00651A0 ERCA00651A1 ERCA00100A0 ERCA00100A1 GF05446X012 GF05446X022 ERCA04149A0 ERCA04149A1 ERCA04149A3 ERCA00100A0 ERCA00100A1 GF05446X012 GF05446X022 ERCA00601A0 ERCA00601A3	18	Drive Screw (4 required), NACE	ERAA01884A0
			19*	Diaphragm Gasket (2 required for pressure loaded spring case) 302 Stainless steel diaphragm Types MR98L and MR98LD 1/4 NPT Body Size 1/2 in. / DN 15 Body Size 3/4 and 1 in. / DN 20 and 25 Body Sizes 1-1/2 and 2 in. / DN 40 and 50 Body Sizes 302 Stainless steel - Oxygen Service diaphragm Type MR98L 1/4 NPT Body Size 1/2 in. / DN 15 Body Size 3/4 and 1 in. / DN 20 and 25 Body Sizes Types MR98H and MR98HH 1/4 NPT Body Size 1/2 in. / DN 15 Body Size 3/4 and 1 in. / DN 20 and 25 Body Sizes 1-1/2 and 2 in. / DN 40 and 50 Body Sizes 302 Stainless steel - Steam Service, Monel <sup>®</sup> and Hastelloy <sup>®</sup> C Diaphragms Types MR98L and MR98LD 1/4 NPT Body Size 1/2 in. / DN 15 Body Size 3/4 and 1 in. / DN 20 and 25 Body Sizes Types MR98H, MR98HD, MR98HH and MR98HHD 1/4 NPT Body Size 1/2 in. / DN 15 Body Size 3/4 and 1 in. / DN 20 and 25 Body Sizes 1-1/2 and 2 in. / DN 40 and 50 Body Sizes	ERCA00655A0 ERCA00491A0 ERCA00556A0 1E393104022 ERCA00485A0 ERCA00510A0 ERCA00526A0 ERCA00655A2 ERCA00491A2 ERCA00556A2 1E3931X0022 ERCA00485A2 ERCA00510A2 ERCA00526A2 ERCA00655A1 ERCA00491A1 ERCA00556A1 1E3931X0012 ERCA00485A1 ERCA00510A1 ERCA00526A1
17	Jam Nut, NACE <sup>(1)</sup> Square Head Adjustment 1/4 NPT Body Size 1/2 in. / DN 15 Body Size 3/4 and 1 in. / DN 20 and 25 Body Sizes 1-1/2 and 2 in. / DN 40 and 50 Body Sizes	ERCA00652A0 ERCA00380A0 GF05453X012 ERCA00633A0	21	Diaphragm Head 1/4 NPT Body Size Steel, NACE <sup>(1)</sup> Stainless steel, NACE	1L345525072 1L3455X0012

\*Recommended Spare Part

1. Part meets NACE requirements only for applications in which the part is not exposed to sour gas.

Monel<sup>®</sup> is a mark owned by Special Metals Corporation.

Hastelloy<sup>®</sup> C is a mark owned by Haynes International, Inc.

# MR98 Series

Key	Description	Part Number	Key	Description	Part Number
21	Diaphragm Head (continued)		28	Lockwasher, NACE <sup>(1)</sup>	
	1/2 in. / DN 15 Body Size			1/4 NPT and 1/2 in. / DN 15 Body Sizes	
	Steel, NACE <sup>(1)</sup>	1L339625072		Steel	ERAA01919A0
	Stainless steel, NACE	1L3396X0012		Stainless steel	ERAA01919A1
	3/4 and 1 in. / DN 20 and 25 Body Sizes			3/4 and 1 in. / DN 20 and 25 Body Sizes	
	Steel, NACE <sup>(1)</sup>	1L342125072		Steel	1H624328992
	Stainless steel, NACE	1L3421X0012		Stainless Steel	1H6243X0012
	1-1/2 and 2 in. / DN 40 and 50 Body Sizes			1-1/2 and 2 in. / DN 40 and 50 Body Sizes	
	(2 required)			Steel	ERCA00379A0
	416 Stainless steel	ERCA00578A0		Stainless steel	ERCA00379A1
22	Adjusting Screw Assembly, NACE		29*	Gasket, NACE	
	Tee Handle Adjustment			Composition Diaphragm	
	1/4 NPT Body Size	ERAA01707A0		1/4 NPT Body Size	GF04913X012
	3/4 and 1 in. / DN 20 and 25 Body Sizes	ERAA01716A0		1/2 in. / DN 15 Body Size	
23	Handwheel, NACE, (1/2 in. / DN 15 Body)	ERAA01694A0	Not pressure loaded spring case	GF04913X012	
	Handwheel, NACE, (1/2 in. / DN 15 Body)	ERAA02088A0	Pressure loaded spring case	ERAA02651A0	
24	Machine Screw		3/4 and 1 in. / DN 20 and 25 Body Sizes	ERCA00502A0	
	1/4 NPT Body Size		Metal Diaphragm		
	416 Stainless steel	GF05033X012	1/4 NPT Body Size (2 required for pressure loaded spring case)		
	316 Stainless steel, NACE, Oxygen Service	GF05033X022	302 Stainless steel	GF04913X012	
	1/2 in. / DN 15 Body Size		302 Stainless steel - Oxygen Service	GF04913X032	
	416 Stainless steel	1J4159X0012	302 Stainless steel - Steam Service, Monel <sup>®</sup> and Hastelloy <sup>®</sup> C	GF04913X022	
	316 Stainless steel, NACE, Oxygen Service	1J4159X0012	1/2 in. / DN 15 Body Size (2 required for pressure loaded spring case)		
	Hastelloy <sup>®</sup> C, NACE	1J4159X0062	302 Stainless steel	ERAA02651A0	
	3/4 and 1 in. / DN 20 and 25 Body Sizes		302 Stainless steel - Oxygen Service	ERAA02651A2	
	416 Stainless steel	1L343538992	302 Stainless steel - Steam Service, Monel <sup>®</sup> and Hastelloy <sup>®</sup> C	ERAA02651A1	
25	O-ring Retainer		3/4 and 1 in. / DN 20 and 25 Body Sizes		
	1/4 NPT Body Size		(2 required for pressure loaded spring case)		
	416 Stainless steel	GF05031X022	302 Stainless steel	ERCA00502A0	
	316 Stainless steel, NACE, Oxygen Service	GF05031X032	302 Stainless steel - Oxygen Service	ERCA00502A2	
	1/2 in. / DN 15 Body Size		302 Stainless steel - Steam Service, Monel <sup>®</sup> and Hastelloy <sup>®</sup> C	ERCA00502A1	
	416 Stainless steel	GF05078X022	1-1/2 and 2 in. / DN 40 and 50 Body Sizes		
	316 Stainless steel, NACE, Oxygen Service	GF05078X032	(2 required)		
	Hastelloy <sup>®</sup> C, NACE	GF05078X052	302 Stainless steel	ERCA00579A0	
	3/4 and 1 in. / DN 20 and 25 Body Sizes		302 Stainless steel - Oxygen Service	ERCA00579A2	
	416 Stainless steel	1L343035132	302 Stainless steel - Steam Service, Monel <sup>®</sup> and Hastelloy <sup>®</sup> C	ERCA00579A1	
25	Seat Retainer		31	Locknut, NACE <sup>(1)</sup>	
	1-1/2 and 2 in. / DN 40 and 50 Body Sizes			1/4 NPT and 1/2 in. / DN 15 Body Sizes	ERCA00663A0
	416 Stainless steel	ERCA00377A0		3/4 and 1 in. / DN 20 and 25 Body Sizes	1L872224122
	316 Stainless steel, NACE, Oxygen Service	ERCA00377A1		1-1/2 and 2 in. / DN 40 and 50 Body Sizes	1P788724122
25	Hastelloy <sup>®</sup> C, NACE	ERCA00377A3	32	Stuffing Box	
				Handwheel adjustment	
				Types MR98LD and MR98HD	
			1/4 NPT Body Size	ERAA02699A0	
			1/2 in. / DN 15 Body Size	ERAA01655A0	
			3/4 and 1 in. / DN 20 and 25 Body Sizes	ERAA01655A0	
			1-1/2 and 2 in. / DN 40 and 50 Body Sizes	ERAA01662A0	

\*Recommended Spare Part

1. Part meets NACE requirements only for applications in which the part is not exposed to sour gas.

Monel<sup>®</sup> is a mark owned by Special Metals Corporation.

Hastelloy<sup>®</sup> C is a mark owned by Haynes International, Inc.

# MR98 Series

Key	Description	Part Number	Key	Description	Part Number
32	Stuffing Box (continued)		36	Packing V-Ring (3 required)	
	Handwheel adjustment (continued)			Types MR98LD and MR98HD	
	Type MR98HHD			1/4 NPT Body Size	ERAA01634A0
	1/4 NPT Body Size	ERAA02699A0		1/2 to 2 in. / DN 15 to 50 Body Sizes	ERAA01657A0
	1/2 in. / DN 15 Body Size	ERAA02700A0		Type MR98HHD	
	3/4 and 1 in. / DN 20 and 25 Body Sizes	ERAA02696A0		1/4 NPT Body Size	ERAA01634A0
	Handwheel adjustment with Stainless steel Trim			1/2 in. / DN 15 Body Size	ERAA01657A0
	Types MR98LD and MR98HD			3/4 and 1 in. / DN 20 and 25 Body Sizes	ERAA02108A0
	1/4 NPT Body Size	ERAA02699A1	37*	Stuff Box Gasket	
	1/2 in. / DN 15 Body Size	ERAA01655A1		1/4 NPT Body Size	ERAA01635A0
	3/4 and 1 in. / DN 20 and 25 Body Sizes	ERAA01655A1		1/2 to 2 in. / DN 15 to 50 Body Sizes	1P494106242
	1-1/2 and 2 in. / DN 40 and 50 Body Sizes	ERAA01662A1	38	Handwheel / Handle	
	Type MR98HHD			Handwheel adjustment	
	1/4 NPT Body Size	ERAA02699A1		Types MR98LD and MR98HD	
	1/2 in. / DN 15 Body Size	ERAA02700A1		1/4 NPT Body Size	ERAA01636A0
	3/4 and 1 in. / DN 20 and 25 Body Sizes	ERAA02696A1		1/2 in. / DN 15 Body Size	ERAA01669A0
33	Adjusting Screw			3/4 and 1 in. / DN 20 and 25 Body Sizes	ERAA01669A0
	Types MR98LD and MR98HD			1-1/2 and 2 in. / DN 40 and 50 Body Sizes	1J410819042
	1/4 NPT Body Size	ERAA01631A0		Type MR98HHD	
	1/2 in. / DN 15 Body Size	ERAA02333A0		1/4 NPT Body Size	ERAA01636A0
	3/4 and 1 in. / DN 20 and 25 Body Sizes	ERAA01673A0		1/2 in. / DN 15 Body Size	ERAA01669A0
	1-1/2 and 2 in. / DN 40 and 50 Body Sizes	ERAA01677A0		3/4 and 1 in. / DN 20 and 25 Body Sizes	ERAA02109A0
	Type MR98HHD			Handwheel adjustment with Stainless steel Trim	
	1/4 NPT Body Size	ERAA01631A0		Types MR98LD and MR98HD	
	1/2 in. / DN 15 Body Size	ERAA01874A0		1/4 NPT Body Size	ERAA02956A1
	3/4 and 1 in. / DN 20 and 25 Body Sizes	ERAA02107A0		1/2 in. / DN 15 Body Size	ERAA02957A1
34	Packing Follower			3/4 and 1 in. / DN 20 and 25 Body Sizes	ERAA02957A1
	Handwheel adjustment			1-1/2 and 2 in. / DN 40 and 50 Body Sizes	ERAA02959A1
	Types MR98LD and MR98HD			Type MR98HHD	
	1/4 NPT Body Size	ERAA01632A0		1/4 NPT Body Size	ERAA02956A1
	1/2 to 2 in. / DN 15 to 50 Body Sizes	1K884924092		1/2 in. / DN 15 Body Size	ERAA02957A1
	Type MR98HHD			3/4 and 1 in. / DN 20 and 25 Body Sizes	ERAA02958A1
	1/4 NPT and 1/2 in. / DN 15 Body Sizes	ERAA01632A0	39	Internal Adaptor	
	3/4 and 1 in. / DN 20 and 25 Body Sizes	1P144024092		Types MR98LD and MR98HD	
	Handwheel adjustment with Stainless steel trim			1/4 NPT Body Size	ERAA01637A0
	Types MR98LD and MR98HD			1/2 to 2 in. / DN 15 to 50 Body Sizes	ERAA01666A0
	1/4 NPT Body Size	ERAA01632A0		Type MR98HHD	
	1/2 to 2 in. / DN 15 to 50 Body Sizes	1K8849X0012		1/4 NPT Body Size	ERAA01637A0
	Type MR98HHD			1/2 in. / DN 15 Body Size	ERAA01666A0
	1/4 NPT and 1/2 in. / DN 15 Body Sizes	ERAA01632A0		3/4 and 1 in. / DN 20 and 25 Body Sizes	ERAA02111A0
	3/4 and 1 in. / DN 20 and 25 Body Sizes	1P1440X0012	40	External Adaptor	
35	Stuffing Box Nut			Types MR98LD and MR98HD	
	Handwheel adjustment			1/4 NPT Body Size	ERAA01638A0
	Types MR98LD and MR98HD	ERAA01633A0		1/2 to 2 in. / DN 15 to 50 Body Sizes	ERAA01667A0
	Type MR98HHD			Type MR98HHD	
	1/4 NPT and 1/2 in. / DN 15 Body Sizes	ERAA01633A0		1/4 NPT Body Size	ERAA01638A0
	3/4 and 1 in. / DN 20 and 25 Body Sizes	1P144124092		1/2 in. / DN 15 Body Size	ERAA01667A0
	Handwheel adjustment with Stainless steel trim			3/4 and 1 in. / DN 20 and 25 Body Sizes	ERAA02112A0
	Types MR98LD and MR98HD	ERAA01633A1	41	Machine Screw	
	Type MR98HHD			Handwheel adjustment	
	1/4 NPT and 1/2 in. / DN 15 Body Sizes	ERAA01633A1		1/4 NPT Body Size	ERAA01639A0
	3/4 and 1 in. / DN 20 and 25 Body Sizes	1P1441X0012		1/2 in. / DN 15 Body Size	ERAA01670A0
				3/4 and 1 in. / DN 20 and 25 Body Sizes	ERAA01670A0

\*Recommended Spare Part

# MR98 Series

Key	Description	Part Number	Key	Description	Part Number
41	Machine Screw (continued)		47	NACE Tag	-----
	Handwheel adjustment with Stainless steel Trim		48	Tag Wire	-----
	1/4 NPT Body Size	ERAA01639A1	49	Lockwasher, For Type MR98HHD,	
	1/2 in. / DN 15 Body Size	ERAA01670A1		3/4 and 1 in. / DN 20 and 25 Body Sizes	
	3/4 and 1 in. / DN 20 and 25 Body Sizes	ERAA01670A1		Steel	ERCA00379A0
41	Jam Nut			Stainless steel	ERCA00379A1
	1-1/2 and 2 in. / DN 40 and 50 Body Sizes		50*	Sealing Washer	
	Handwheel	ERAA01688A0		1/2 in. / DN 15 Body Size	1V205699012
	Handwheel adjustment with Stainless steel Trim	ERAA01688A1		3/4 and 1 in. / DN 20 and 25 Body Sizes	11A9681X012
42	Spring			1-1/2 and 2 in. / DN 40 and 50 Body Sizes	1V424699012
	Types MR98LD and MR98HD	ERAA01640A0	51	Vent	
	Type MR98HHD			Type MR98HH	
	1/4 NPT and 1/2 in. / DN 15 Body Sizes	ERAA01640A0		1/4 NPT Body	0L078343062
	3/4 and 1 in. / DN 20 and 25 Body Sizes	ERAA02110A0		1/2 to 1 in. / DN 15 to 25 Body Sizes	ERAA02123A0
43	Washer			Type MR98H	
	Types MR98LD and MR98HD			1-1/2 and 2 in. / DN 40 and 50 Body Sizes	ERAA02123A0
	1/4 NPT Body Size	ERAA01641A0	52	Plug, 1/2 to 2 in. / DN 15 to 50 Body Sizes	ERAA01942A0
	1/2 to 2 in. / DN 15 to 50 Body Sizes	ERAA01660A0	53*	Valve Plug O-ring	
	Type MR98HHD			1/2 in. / DN 15 Body Size	
	1/4 NPT Body Size	ERAA01641A0		Ethylene Propylene (EPDM)	ERCA02968A2
	1/2 in. / DN 15 Body Size	ERAA01660A0		Fluorocarbon (FKM)	ERCA02968A1
	3/4 and 1 in. / DN 20 and 25 Body Sizes	1H941736042		Perfluoroelastomer (FFKM)	ERCA02968A3
44	Washer			Nitrile (NBR)	ERCA02968A0
	Handwheel adjustment			3/4 and 1 in. / DN 20 and 25 Body Sizes	
	1/4 NPT Body Size	ERAA01642A0		Ethylene Propylene (EPDM)	ERCA00973A2
	1/2 in. / DN 15 Body Size	ERAA01671A0		Fluorocarbon (FKM)	ERCA00973A1
	3/4 and 1 in. / DN 20 and 25 Body Sizes	ERAA01671A0		Perfluoroelastomer (FFKM)	ERCA00973A3
	1-1/2 and 2 in. / DN 40 and 50 Body Sizes	ERAA01689A0		Nitrile (NBR)	ERCA00973A0
	Handwheel adjustment with Stainless steel Trim			1-1/2 and 2 in. / DN 40 and 50 Body Sizes	
	1/4 NPT Body Size	ERAA01642A1		Ethylene Propylene (EPDM)	ERCA01406A2
	1/2 in. / DN 15 Body Size	ERAA01671A1		Fluorocarbon (FKM)	ERCA01406A1
	3/4 and 1 in. / DN 20 and 25 Body Sizes	ERAA01671A1		Perfluoroelastomer (FFKM)	ERCA01406A3
	1-1/2 and 2 in. / DN 40 and 50 Body Sizes	ERAA01689A1		Nitrile (NBR)	ERCA01406A0
45*	O-ring		57	Jam Nut, Type MR98HHD,	
	1/4 NPT Body Size			3/4 and 1 in. / DN 20 and 25 Body Sizes	
	Nitrile (NBR)	ERAA01672A0		Handwheel adjustment	ERCA00380A0
	Fluorocarbon (FKM)	ERAA01672A1		Handwheel adjustment with Stainless steel Trim	ERCA00380A1
	Ethylene Propylene (EPDM)	ERAA01672A2	58	Washer	
	1/2 in. / DN 15 Body Size			1/4 NPT Body Size	
	Nitrile (NBR)	ERAA01672A0		416 Stainless steel	GF05050X012
	Fluorocarbon (FKM)	ERAA01672A1		316 Stainless steel, NACE, Oxygen Service	GF05050X022
	Ethylene Propylene (EPDM)	ERAA01672A2		Hastelloy® C, NACE	GF05050X032
	3/4 and 1 in. / DN 20 and 25 Body Sizes			Monel®, NACE	GF05050X042
	Nitrile (NBR)	ERAA02070A0		1/2 in. / DN 15 Body Size	
	1-1/2 and 2 in. / DN 40 and 50 Body Sizes			416 Stainless steel	GF05050X012
	Nitrile (NBR)	ERCA00664A0		316 Stainless steel, NACE, Oxygen Service	GF05050X022
	Fluorocarbon (FKM)	ERCA00664A1		Hastelloy® C, NACE	GF05050X042
	Ethylene Propylene (EPDM)	ERCA00664A2		Monel®, NACE	GF05050X032

\*Recommended Spare Part  
 Monel® is a mark owned by Special Metals Corporation.  
 Hastelloy® C is a mark owned by Haynes International, Inc.

# MR98 Series

Key	Description	Part Number	Key	Description	Part Number
58	Washer (continued) 3/4 and 1 in. / DN 20 and 25 Body Sizes		63*	Bottom Plug Seal (continued) 3/4 and 1 in. / DN 20 and 25 Body Sizes	
	416 Stainless steel	GF05525X012		Nitrile (NBR)	ERCA00628A0
	316 Stainless steel, NACE, Oxygen Service	GF05525X022		Perfluoroelastomer (FFKM)	ERCA00628A3
	Hastelloy® C, NACE	GF05525X042		Fluorocarbon (FKM)	ERCA00628A1
	Monel®, NACE	GF05525X032		Ethylenepropylene (EPDM)	ERCA00628A2
59*	O-ring			Graphite	ERCA00517A0
	1/4 NPT Body Size			1-1/2 and 2 in. / DN 40 and 50 Body Sizes	
	Nitrile (NBR) seat	ERCA02967A0		Nitrile (NBR)	ERCA00630A0
	Fluorocarbon (FKM) seat	ERCA02967A1		Fluorocarbon (FKM)	ERCA00630A1
	Ethylene Propylene (EPDM) seat	ERCA02967A2		Ethylenepropylene (EPDM)	ERCA00630A2
	1/2 in. / DN 15 Body Size			Graphite	ERCA01407A0
	Nitrile (NBR) seat	ERCA02974A0	64	Flow Arrow	-----
	Fluorocarbon (FKM) seat	ERCA02974A1	65	Pipe Plug	
	Ethylene Propylene (EPDM) seat	ERCA02974A2		3/4 to 2 in. / DN 20 to 50 Body Sizes	
	Perfluoroelastomer (FFKM) seat	ERCA02974A3		Steel	ERAA03130A0
	3/4 and 1 in. / DN 20 and 25 Body Sizes			Stainless steel	ERAA03131A0
	Nitrile (NBR) seat	ERCA00974A0	66	Pressure Gauge	
	Fluorocarbon (FKM) seat	ERCA00974A1		3/4 to 2 in. / DN 20 to 50 Body Sizes	
	Ethylene Propylene (EPDM) seat	ERCA00974A2		0 to 15 psig / 0 to 1.0 bar	
	Perfluoroelastomer (FFKM) seat	ERCA00974A3		Brass	11B8579X012
59*	L-ring			Stainless steel	ERAA03132A0
	1-1/2 and 2 in. / DN 40 and 50 Body Sizes			0 to 30 psig / 0 to 2.1 bar	
	Nitrile (NBR) seat	ERCA00668A1		Brass	11B8579X022
	Fluorocarbon (FKM) seat	ERCA00668A2		Stainless steel	ERAA03132A1
	Ethylene Propylene (EPDM) seat	ERCA00668A3		0 to 60 psig / 0 to 4.1 bar	
	Perfluoroelastomer (FFKM) seat	ERCA00668A5		Brass	11B8579X032
62	Adaptor, NACE			Stainless steel	ERAA03132A2
	Types MR98L and MR98LD,			0 to 160 psig / 0 to 11.0 bar	
	3/4 and 1 in. / DN 20 and 25 Body Sizes	ERAA01930A0		Brass	11B8579X042
63*	Bottom Plug Seal			Stainless steel	ERAA03132A3
	1/4 NPT Body Size			0 to 300 psig / 0 to 20.7 bar	
	Nitrile (NBR)	ERCA03017A0		Brass	11B8579X052
	Perfluoroelastomer (FFKM)	ERCA03017A3		Stainless steel	ERAA03132A4
	Fluorocarbon (FKM)	ERCA03017A1		0 to 1000 psig / 0 to 68.9 bar	
	Ethylenepropylene (EPDM)	ERCA03017A2		Brass	11B8579X102
	Graphite	ERCA02976A0		Stainless steel	ERAA03132A5
	1/2 in. / DN 15 Body Size		68	Restriction, NACE	
	Nitrile (NBR)	ERCA03016A0		Types MR98HH and MR98HHD,	
	Fluorocarbon (FKM)	ERCA03016A1		3/4 and 1 in. / DN 20 and 25 Body Sizes	ERAA03257A0
	Ethylenepropylene (EPDM)	ERCA03016A2	69	ATEX Tag	-----
	Graphite	ERCA02978A0	70	PED Tag	-----

\*Recommended Spare Part  
 Monel® is a mark owned by Special Metals Corporation.  
 Hastelloy® C is a mark owned by Haynes International, Inc.

# MR98 Series

Key 1, Types MR98L and MR98LD Body Part Numbers

BODY SIZE	END CONNECTION STYLE	BODY MATERIAL						
		Gray Cast Iron	WCC Steel	LCC Steel	CF8M Stainless Steel <sup>(1)</sup>	CF3M Stainless Steel <sup>(1)</sup>	Monel <sup>®(1)</sup>	Hastelloy <sup>®</sup> C <sup>(1)</sup>
1/4 in.	NPT	ERCA03713A0	ERCA03713A1	ERCA03713A7	ERCA03713A4	ERCA03713A3	-----	-----
1/2 in. / DN 15 Without Control Line	NPT	ERCA03819A0	ERCA03819A1	ERCA03819A7	ERCA03819A4	ERCA03819A3	ERCA03819A9	ERCA03819B1
	SWE	-----	ERAA01848A0	ERAA01848A4	ERAA01848A2	ERAA01848A1	-----	-----
	Welded CL150 RF	-----	ERAA01830A0	ERAA01830A3	ERAA01830A2	ERAA01830A1	-----	-----
	Welded CL300 RF	-----	ERAA01832A0	ERAA01832A3	ERAA01832A2	ERAA01832A1	-----	-----
	Welded PN 16/25/40 RF	-----	ERAA01834A0	ERAA01834A2	-----	ERAA01834A1	-----	-----
1/2 in. / DN 15 With Control Line	NPT	-----	ERAA01932A1	ERAA01932A4	ERAA01932A3	ERAA01932A2	-----	-----
3/4 in. / DN 20 Without Gauge Port and Control Line	NPT	ERCA01384A0	ERCA01384A1	ERCA01384A7	ERCA01384A4	ERCA01384A3	ERCA01384A9	ERCA01384B1
	SWE	-----	ERAA01785A1	ERAA01785A6	ERAA01785A4	ERAA01785A3	-----	-----
	Welded CL150 RF	-----	ERAA01797A0	ERAA01797A3	ERAA01797A2	ERAA01797A1	-----	-----
	Welded CL300 RF	-----	ERAA01799A0	ERAA01799A3	ERAA01799A2	ERAA01799A1	-----	-----
	Welded PN 16/25/40 RF	-----	ERAA01801A0	ERAA01801A2	-----	ERAA01801A1	-----	-----
3/4 in. / DN 20 With Control Line but Without Gauge Port	NPT	-----	ERAA02175A1	ERAA02175A4	ERAA02175A3	ERAA02175A2	-----	-----
3/4 in. / DN 20 With Gauge Port but Without Control Line	NPT	ERAA02176A0	ERAA02176A1	ERAA02176A4	ERAA02176A3	ERAA02176A2	-----	-----
	Welded CL150 RF	-----	ERAA02177A1	ERAA02177A4	ERAA02177A3	ERAA02177A2	-----	-----
	Welded CL300 RF	-----	ERAA02178A1	ERAA02178A4	ERAA02178A3	ERAA02178A2	-----	-----
	Welded PN 16/25/40 RF	-----	ERAA02179A1	ERAA02179A3	-----	ERAA02179A2	-----	-----
1 in. / DN 25 Without Gauge Port and Control Line	NPT	ERCA03676A0	ERCA03676A1	ERCA03676A7	ERCA03676A4	ERCA03676A3	ERCA03676A9	ERCA03676B1
	SWE	-----	ERAA01787A1	ERAA01787A6	ERAA01787A4	ERAA01787A3	-----	-----
	Welded CL150 RF	-----	ERAA01803A0	ERAA01803A3	ERAA01803A2	ERAA01803A1	-----	-----
	Welded CL300 RF	-----	ERAA01805A0	ERAA01805A3	ERAA01805A2	ERAA01805A1	-----	-----
	Welded PN 16/25/40 RF	-----	ERCA00553A0	ERCA00553A2	-----	ERCA00553A1	-----	-----
1 in. / DN 25 With Control Line but Without Gauge Port	NPT	-----	ERAA02218A1	ERAA02218A4	ERAA02218A3	ERAA02218A2	-----	-----
1 in. / DN 25 With Gauge Port but Without Control Line	NPT	ERAA02219A0	ERAA02219A1	ERAA02219A4	ERAA02219A3	ERAA02219A2	-----	-----
	Welded CL150 RF	-----	ERAA02220A1	ERAA02220A4	ERAA02220A3	ERAA02220A2	-----	-----
	Welded CL300 RF	-----	ERAA02221A1	ERAA02221A4	ERAA02221A3	ERAA02221A2	-----	-----
	Welded PN 16/25/40 RF	-----	ERAA02222A1	ERAA02222A3	-----	ERAA02222A2	-----	-----

1. Meets the chemical and physical requirements of NACE MR0175-2002 and NACE MR0103.  
NOTE: Contact your local Sales Office if additional gauge and control line options are needed.

- continued -

Monel<sup>®</sup> is a mark owned by Special Metals Corporation.  
Hastelloy<sup>®</sup> C is a mark owned by Haynes International, Inc.



# MR98 Series

Key 1, Types MR98H, MR98HD, MR98HH and MR98HHD Body Part Numbers (continued)

BODY SIZE	END CONNECTION STYLE	BODY MATERIAL							
		Gray Cast Iron <sup>(2)</sup>	WCC Steel	LCC Steel	CF8M Stainless Steel <sup>(1)</sup>	CF3M Stainless Steel <sup>(1)</sup>	Monel <sup>®</sup> (1)	Hastelloy <sup>®</sup> C <sup>(1)</sup>	Aluminum-Bronze
1/4 in.	NPT	ERCA03697A0	ERCA03697A1	ERCA03697A7	ERCA03697A4	ERCA03697A3	-----	-----	-----
1/2 in. / DN 15 Without Control Line	NPT	ERCA03818A0	ERCA03818A1	ERCA03818A7	ERCA03818A4	ERCA03818A3	ERCA03818A9	ERCA03818B1	-----
	SWE	-----	ERAA01829A0	ERAA01829A4	ERAA01829A2	ERAA01829A1	-----	-----	-----
	Welded CL150 RF	-----	ERAA01831A0	ERAA01831A3	ERAA01831A2	ERAA01831A1	-----	-----	-----
	Welded CL300 RF	-----	ERAA01833A0	ERAA01833A3	ERAA01833A2	ERAA01833A1	-----	-----	-----
	Welded PN 16/25/40 RF	-----	ERAA01835A0	ERAA01835A2	-----	ERAA01835A1	-----	-----	-----
	Integral CL150 RF	-----	-----	-----	-----	ERAA02400A0	ERAA02400A1	ERAA02400A2	ERAA02400A3
	Integral CL300 RF	-----	-----	-----	-----	ERAA02401A0	ERAA02401A1	ERAA02401A2	ERAA02401A3
1/2 in. / DN 15 With Control Line	NPT	-----	ERAA01934A1	ERAA01934A4	ERAA01934A3	ERAA01934A2	-----	-----	-----
	Welded CL150 RF	-----	ERAA01936A0	ERAA01936A3	ERAA01936A2	-----	-----	-----	-----
	Welded CL300 RF	-----	ERAA01937A0	ERAA01937A3	ERAA01937A2	-----	-----	-----	-----
3/4 in. / DN 20 Without Gauge Port and Control Line	NPT	ERCA01383A0	ERCA01383A1	ERCA01383A7	ERCA01383A4	ERCA01383A3	ERCA01383A9	ERCA01383B1	-----
	SWE	-----	ERAA01786A1	ERAA01786A6	ERAA01786A4	ERCA01786A3	-----	-----	-----
	Welded CL150 RF	-----	ERAA01798A0	ERAA01798A3	ERAA01798A2	ERAA01798A1	-----	-----	-----
	Welded CL300 RF	-----	ERAA01800A0	ERAA01800A3	ERAA01800A2	ERAA01800A1	-----	-----	-----
	Welded PN 16/25/40 RF	-----	ERAA01802A0	ERAA01802A2	-----	ERAA01802A1	-----	-----	-----
3/4 in. / DN 20 With Control Line but Without Gauge Port	NPT	-----	ERAA02211A1	ERAA02211A4	ERAA02211A3	ERAA02211A2	-----	-----	-----
	Welded CL150 RF	-----	ERAA02477A0	ERAA02477A3	ERAA02477A2	-----	-----	-----	-----
	Welded CL300 RF	-----	ERAA02478A0	ERAA02478A3	ERAA02478A2	-----	-----	-----	-----
3/4 in. / DN 20 With Gauge Port but Without Control Line	NPT	ERAA02212A0	ERAA02212A1	ERAA02212A4	ERAA02212A3	ERAA02212A2	-----	-----	-----
	Welded CL150 RF	-----	ERAA02215A1	ERAA02215A4	ERAA02215A3	ERAA02215A2	-----	-----	-----
	Welded CL300 RF	-----	ERAA02216A1	ERAA02216A4	ERAA02216A3	ERAA02216A2	-----	-----	-----
	Welded PN 16/25/40 RF	-----	ERAA02217A1	ERAA02217A3	-----	ERAA02217A2	-----	-----	-----
1 in. / DN 25 Without Gauge Port and Control Line	NPT	ERCA03673A0	ERCA03673A1	ERCA03673A7	ERCA03673A4	ERCA03673A3	ERCA03673A9	ERCA03673B1	-----
	SWE	-----	ERAA01788A1	ERAA01788A6	ERAA01788A4	ERAA01788A3	-----	-----	-----
	Welded CL150 RF	-----	ERAA01804A0	ERAA01804A3	ERAA01804A2	ERAA01804A1	-----	-----	-----
	Welded CL300 RF	-----	ERAA01806A0	ERAA01806A3	ERAA01806A2	ERAA01806A1	-----	-----	-----
	Welded PN 16/25/40 RF	-----	ERAA01793A0	ERAA01793A2	-----	ERAA01793A1	-----	-----	-----
	Integral CL150 RF	-----	-----	-----	-----	ERAA01792A0	ERAA01792A4	ERAA01792A5	ERAA01792A6
	Integral CL300 RF	-----	-----	-----	-----	ERCA04332A2	ERCA04332A4	ERCA04332A5	ERCA04332A6
1 in. / DN 25 With Control Line but Without Gauge Port	NPT	-----	ERAA02214A1	ERAA02214A4	ERAA02214A3	ERAA02214A2	-----	-----	-----
	Welded CL150 RF	-----	ERAA02479A0	ERAA02479A3	ERAA02479A2	-----	-----	-----	-----
	Welded CL300 RF	-----	ERAA02480A0	ERAA02480A3	ERAA02480A2	-----	-----	-----	-----
1 in. / DN 25 With Gauge Port but Without Control Line	NPT	ERAA02213A0	ERAA02213A1	ERAA02213A4	ERAA02213A3	ERAA02213A2	-----	-----	-----
	Welded CL150 RF	-----	ERAA02223A1	ERAA02223A4	ERAA02223A3	ERAA02223A2	-----	-----	-----
	Welded CL300 RF	-----	ERAA02224A1	ERAA02224A4	ERAA02224A3	ERAA02224A2	-----	-----	-----
	Welded PN 16/25/40 RF	-----	ERAA02225A1	ERAA02225A3	-----	ERAA02225A2	-----	-----	-----

1. Meets the chemical and physical requirements of NACE MR0175-2002 and NACE MR0103.  
2. Available for Types MR98H and MR98HD only.  
NOTE: Contact your local Sales Office if additional gauge and control line options are needed.

- continued -

Monel<sup>®</sup> is a mark owned by Special Metals Corporation.  
Hastelloy<sup>®</sup> C is a mark owned by Haynes International, Inc.

# MR98 Series

Key 1, Types MR98H and MR98HD Body Part Numbers (continued)

BODY SIZE	END CONNECTION STYLE	BODY MATERIAL							
		Gray Cast Iron	WCC Steel	LCC Steel	CF8M Stainless Steel <sup>(1)</sup>	CF3M Stainless Steel <sup>(1)</sup>	Monel <sup>(9)(1)</sup>	Hastelloy <sup>®</sup> C <sup>(1)</sup>	Aluminum-Bronze
1-1/2 in. / DN 40 Without Gauge Port and Control Line	NPT	ERCA01385A0	ERCA01385A1	ERCA01385A7	ERCA01385A3	ERCA01385A2	ERCA01385A4	ERCA01385A9	-----
	SWE	-----	ERAA01795A0	ERAA01795A4	ERAA01795A2	ERAA01795A1	-----	-----	-----
	Welded CL150 RF	-----	ERAA01770A0	ERAA01770A3	ERAA01770A2	ERAA01770A1	-----	-----	-----
	Welded CL300 RF	-----	ERAA01771A0	ERAA01771A3	ERAA01771A2	ERAA01771A1	-----	-----	-----
	Welded PN16/25/40 RF	-----	ERAA01772A0	ERAA01772A2	-----	ERAA01772A1	-----	-----	-----
1-1/2 in. / DN 40 With Control Line but Without Gauge Port	NPT	-----	ERAA01944A1	ERAA01944A4	ERAA01944A3	ERAA01944A2	-----	-----	-----
	Welded CL150 RF	-----	ERAA01948A0	ERAA01948A3	ERAA01948A2	-----	-----	-----	-----
	Welded CL300 RF	-----	ERAA01949A0	ERAA01949A3	ERAA01949A2	-----	-----	-----	-----
1-1/2 in. / DN 40 With Gauge Port but Without Control Line	NPT	ERAA02511A0	ERAA02511A1	ERAA02511A4	ERAA02511A3	ERAA02511A2	-----	-----	-----
	Welded CL150 RF	-----	ERAA02502A0	ERAA02502A3	ERAA02502A2	ERAA02502A1	-----	-----	-----
	Welded CL300 RF	-----	ERAA02503A0	ERAA02503A3	ERAA02503A2	ERAA02503A1	-----	-----	-----
	Welded PN 16/25/40 RF	-----	ERAA02504A0	ERAA02504A2	-----	ERAA02504A1	-----	-----	-----
2 in. / DN 50 Without Gauge Port and Control Line	NPT	ERCA03767A0	ERCA03767A1	ERCA03767A7	ERCA03767A4	ERCA03767A3	ERCA03767A9	ERCA03767B1	-----
	SWE	-----	ERAA01796A0	ERAA01796A4	ERAA01796A2	ERAA01796A1	-----	-----	-----
	Welded CL150 RF	-----	ERAA01773A0	ERAA01773A3	ERAA01773A2	ERAA01773A1	-----	-----	-----
	Welded CL300 RF	-----	ERAA01774A0	ERAA01774A3	ERAA01774A2	ERAA01774A1	-----	-----	-----
	Welded PN 16/25/40 RF	-----	ERAA01775A0	ERAA01775A2	-----	ERAA01775A1	-----	-----	-----
	Integral CL150 RF	-----	-----	-----	-----	ERAA01781A0	ERAA01781A1	ERAA01781A2	ERAA01781A3
	Integral CL300 RF	-----	-----	-----	-----	ERCA04258A0	ERCA04258A1	ERCA04258A2	ERCA04258A3
2 in. / DN 50 With Control Line but Without Gauge Port	NPT	-----	ERAA01945A1	ERAA01945A4	ERAA01945A3	ERAA01945A2	-----	-----	-----
	Welded CL150 RF	-----	ERAA01951A0	ERAA01951A3	ERAA01951A2	-----	-----	-----	-----
	Welded CL300 RF	-----	ERAA01952A0	ERAA01952A3	ERAA01952A2	-----	-----	-----	-----
2 in. / DN 50 With Gauge Port but Without Control Line	NPT	ERAA02512A0	ERAA02512A1	ERAA02512A4	ERAA02512A3	ERAA02512A2	-----	-----	-----
	Welded CL150 RF	-----	ERAA02505A0	ERAA02505A3	ERAA02505A2	ERAA02505A1	-----	-----	-----
	Welded CL300 RF	-----	ERAA02506A0	ERAA02506A3	ERAA02506A2	ERAA02506A1	-----	-----	-----
	Welded PN 16/25/40 RF	-----	ERAA02507A0	ERAA02507A2	-----	ERAA02507A1	-----	-----	-----

1. Meets the chemical and physical requirements of NACE MR0175-2002 and NACE MR0103.  
NOTE: Contact your local Sales Office if additional gauge and control line options are needed.

Monel<sup>®</sup> is a mark owned by Special Metals Corporation.  
Hastelloy<sup>®</sup> C is a mark owned by Haynes International, Inc.

# MR98 Series

## Key 2, Spring Case Part Numbers

TYPE	BODY SIZE		STYLE	SPRING CASE MATERIAL					
	In.	DN		Gray Cast Iron	WCC Steel	LCC Steel	CF8M Stainless Steel	Monel®	Hastelloy® C
MR98L	1/4 NPT	----	Drilled Hole (Standard)	ERCA03546A0	ERCA02874A0 <sup>(1)</sup>	ERCA02874A3 <sup>(1)</sup>	ERCA02874A2 <sup>(1)</sup>	-----	-----
			1/4 NPT Vent	ERCA00609A1	ERAA01872A2 <sup>(1)</sup>	ERAA01872A3 <sup>(1)</sup>	ERAA01872A3 <sup>(1)</sup>	-----	-----
	1/2	15	Drilled Hole (Standard)	ERCA03564A0	ERCA02883A0 <sup>(1)</sup>	ERCA02883A3 <sup>(1)</sup>	ERCA02883A2 <sup>(1)</sup>	-----	-----
			1/4 NPT Vent	ERCA00615A0	ERAA01885A0 <sup>(1)</sup>	ERAA01885A4 <sup>(1)</sup>	ERAA01885A1 <sup>(1)</sup>	ERAA01885A2 <sup>(1)</sup>	ERAA01885A3 <sup>(1)</sup>
	3/4 and 1	20 and 25	Drilled Hole (Standard)	ERCA03497A0	ERCA02908A0 <sup>(1)</sup>	ERCA02908A3 <sup>(1)</sup>	ERCA02908A2 <sup>(1)</sup>	-----	-----
			1/4 NPT Vent	ERCA00623A0	ERCA00621A2 <sup>(1)</sup>	ERCA00621A6 <sup>(1)</sup>	ERCA00621A3 <sup>(1)</sup>	ERCA00621A4 <sup>(1)</sup>	ERCA00621A5 <sup>(1)</sup>
MR98LD	1/4 NPT	----	1/4 NPT Vent (Standard)	-----	ERCA03517A0	ERCA03517A3	ERCA03517A2	-----	-----
	1/2	15	1/4 NPT Vent (Standard)	-----	ERCA03531A0	ERCA03531A3	ERCA03531A2	-----	-----
	3/4 and 1	20 and 25	1/4 NPT Vent (Standard)	-----	ERCA04405A0	ERCA04405A2	ERCA04405A1	-----	-----
MR98H	1/4 NPT	----	Drilled Hole (Standard)	ERCA03544A0	ERCA02872A0 <sup>(1)</sup>	ERCA02872A3 <sup>(1)</sup>	ERCA02872A2 <sup>(1)</sup>	-----	-----
			1/4 NPT Vent	ERCA00610A1	ERAA01873A2 <sup>(1)</sup>	ERAA01873A4 <sup>(1)</sup>	ERAA01873A3 <sup>(1)</sup>	-----	-----
	1/2	15	Drilled Hole (Standard)	ERCA03562A0	ERCA02881A0 <sup>(1)</sup>	ERCA02881A3 <sup>(1)</sup>	ERCA02881A2 <sup>(1)</sup>	-----	-----
			1/4 NPT Vent	ERCA00616A0	ERAA01886A0 <sup>(1)</sup>	ERAA01886A4 <sup>(1)</sup>	ERAA01886A1 <sup>(1)</sup>	ERAA01886A2 <sup>(1)</sup>	ERAA01886A3 <sup>(1)</sup>
	3/4 and 1	20 and 25	Drilled Hole (Standard)	ERCA03496A0	ERCA02907A0 <sup>(1)</sup>	ERCA02907A3 <sup>(1)</sup>	ERCA02907A2 <sup>(1)</sup>	-----	-----
			1/4 NPT Vent	ERCA00624A0	ERCA00622A2 <sup>(1)</sup>	ERCA00622A6 <sup>(1)</sup>	ERCA00622A3 <sup>(1)</sup>	ERCA00622A4 <sup>(1)</sup>	ERCA00622A5 <sup>(1)</sup>
1-1/2 and 2	40 and 50	1/4 NPT Vent	ERCA03641A0	ERCA02900A0 <sup>(1)</sup>	ERCA02900A5 <sup>(1)</sup>	ERCA02900A2 <sup>(1)</sup>	ERCA02900A3 <sup>(1)</sup>	ERCA02900A4 <sup>(1)</sup>	
MR98HD	1/4 NPT	----	1/4 NPT Vent (Standard)	-----	ERCA03515A0	ERCA03515A3	ERCA03515A2	-----	-----
	1/2	15	1/4 NPT Vent (Standard)	-----	ERCA03529A0	ERCA03529A3	ERCA03529A2	-----	-----
	3/4 and 1	20 and 25	1/4 NPT Vent (Standard)	-----	ERCA03499A0	ERCA03499A3	ERCA03499A2	-----	-----
	1-1/2 and 2	40 and 50	1/4 NPT Vent (Standard)	-----	ERCA03691A0	ERCA03691A3	ERCA03691A2	-----	-----
MR98HH	1/4 NPT	----	1/4 NPT Vent	-----	ERCA01262A0 <sup>(1)</sup>	ERCA01262A3 <sup>(1)</sup>	ERCA01262A2 <sup>(1)</sup>	-----	-----
	1/2	15	1/4 NPT Vent	-----	ERCA00619A0 <sup>(1)</sup>	ERCA00619A3 <sup>(1)</sup>	ERCA00619A2 <sup>(1)</sup>	-----	-----
	3/4 and 1	20 and 25	1/4 NPT Vent	-----	ERCA03279A0 <sup>(1)</sup>	ERCA03279A3 <sup>(1)</sup>	ERCA03279A2 <sup>(1)</sup>	-----	-----
MR98HHD	1/4 NPT	----	1/4 NPT Vent (Standard)	-----	ERCA01358A0	ERCA01358A3	ERCA01358A2	-----	-----
	1/2	15	1/4 NPT Vent (Standard)	-----	ERCA01381A0	ERCA01381A3	ERCA01381A2	-----	-----
	3/4 and 1	20 and 25	1/4 NPT Vent (Standard)	-----	ERCA01360A0	ERCA01360A3	ERCA01360A2	-----	-----

1. Meets the chemical and physical requirements of NACE MR0175-2002 and NACE MR0103.

## Key 4\*, Valve Plug, Metal Seat

BODY SIZE		BODY STYLE	VALVE PLUG MATERIAL				
In.	DN		416 Stainless Steel	316 Stainless Steel <sup>(1)</sup>	Alloy 6 <sup>(1)</sup>	Hastelloy® C <sup>(1)</sup>	Monel <sup>(1)</sup>
1/4 NPT	----	Without control line	GF04909X022	GF04909X032	-----	GF04909X052	GF04909X042
1/2	15	Without control line	ERCA01337A0	ERCA01337A1	ERCA01337A4	ERCA01337A3	ERCA01337A2
		With control line	ERCA01305A0	ERCA01305A1	-----	ERCA01305A3	ERCA01305A2
3/4 and 1	20 and 25	Without control line	GF04828X022	GF04828X032	GF04828X062	GF04828X052	GF04828X042
		With control line	GF05479X022	GF05479X032	-----	GF05479X052	GF05479X042
1-1/2 and 2	40 and 50	Without control line	GF04899X022	GF04899X032	GF04899X062	GF04899X052	GF04899X042
		With control line and with composition diaphragm	GF05514X022	GF05514X032	-----	GF05514X052	GF05514X042
		With control line and with metal diaphragm	GF05514X022	GF05514X032	-----	GF05518X052	GF05518X042

1. NACE MR0175-2002 and NACE MR0103

\*Recommended Spare Part

Monel® is a mark owned by Special Metals Corporation.  
Hastelloy® C is a mark owned by Haynes International, Inc.

# MR98 Series

Key 4\*, Valve Plug, Composition Seat

BODY SIZE		BODY STYLE	VALVE PLUG MATERIAL		
In.	DN		416 Stainless Steel	316 Stainless Steel <sup>(1)(2)</sup>	Hastelloy® C <sup>(1)</sup>
1/4 NPT	----	Without control line	GF05032X022	GF05032X032	-----
1/2	15	Without control line	ERCA01338A0	ERCA01338A1	-----
		With control line	ERCA01333A0	ERCA01333A1	ERCA01333A3
3/4 and 1	20 and 25	Without control line	GF04829X022	GF04829X032	-----
		With control line	GF05547X022	GF05547X032	GF05547X052
1-1/2 and 2	40 and 50	Without control line	GF05520X022	GF05520X032	-----
		With control line	GF05518X022	GF05518X032	GF05518X052

\*Recommended Spare Part  
1. NACE MR0175-2002 and NACE MR0103  
2. Oxygen Service

Key 12\* Composition Diaphragm, NACE

TYPE	BODY SIZE		DIAPHRAGM MATERIAL		
	In.	DN	Neoprene (CR)	Fluorocarbon (FKM) (2 required)	EPDM (2 required)
MR98L and MR98LD	1/4 NPT	----	GF05051X012	GF05051X022	GF05051X032
	1/2	15	ERCA00514A0	ERCA00514A1	ERCA00514A2
	3/4 and 1	20 and 25	ERCA00603A0	ERCA00603A1	ERCA00603A2
MR98H, MR98HH MR98HD and MR98HHD	1/4 NPT	----	GF05045X012	GF05045X022	GF05045X032
	1/2	15	ERCA00512A0	ERCA00512A1	ERCA00512A2
	3/4 and 1	20 and 25	ERCA00518A0	ERCA00518A1	ERCA00518A2
	1-1/2 and 2	40 and 50	ERCA00661A0	ERCA00661A1	ERCA00661A2

\*Recommended Spare Part

Key 12\* Metal Diaphragm

TYPE	BODY SIZE		BODY MATERIAL (2 REQUIRED)			
	In.	DN	302 Stainless Steel	302 Stainless Steel (Oxygen Service)	Monel®	Hastelloy® C
MR98L	1/4 NPT	----	GF05030X012 <sup>(1)</sup>	GF05030X022 <sup>(1)</sup>	GF05030X032 <sup>(1)</sup>	GF05030X042 <sup>(1)</sup>
	1/2	15	ERCA00506A0	ERCA00506A1	ERCA00506A2	ERCA00506A3
	3/4 and 1	20 and 25	ERCA00112A0	ERCA00112A1	ERCA00112A2	ERCA00112A3
MR98H	1/4 NPT	----	GF04912X012	GF04912X022	GF04912X032	GF04912X042
	1/2	15	ERCA00496A0	ERCA00496A1	ERCA00496A2	ERCA00496A3
	3/4 and 1	20 and 25	GF05737X022	GF05737X032	GF05737X042	GF05737X052
	1-1/2 and 2	40 and 50	ERCA00527A0	ERCA00527A1	ERCA00527A2	ERCA00527A3
MR98LD	1/4 NPT	----	GF05030X012 <sup>(1)</sup>	-----	GF05030X032 <sup>(1)</sup>	GF05030X042 <sup>(1)</sup>
	1/2	15	ERCA00506A0	-----	ERCA00506A2	ERCA00506A3
	3/4 and 1	20 and 25	ERCA00112A0	-----	ERCA00112A2	ERCA00112A3
MR98HD	1/4 NPT	----	GF04912X012	-----	GF04912X032	GF04912X042
	1/2	15	ERCA00496A0	-----	ERCA00496A2	ERCA00496A3
	3/4 and 1	20 and 25	GF05737X022	-----	GF05737X042	GF05737X052
	1-1/2 and 2	40 and 50	ERCA00527A0	-----	ERCA00527A2	ERCA00527A3
MR98HH	1/4 NPT	----	GF04912X012	GF04912X022	GF04912X032	GF04912X042
	1/2	15	ERCA00496A0	ERCA00496A1	ERCA00496A2	ERCA00496A3
	3/4 and 1	20 and 25	GF05737X022	GF05737X032	GF05737X042	GF05737X052
MR98HHD	1/4 NPT	----	GF04912X012	-----	GF04912X032	GF04912X042
	1/2	15	ERCA00496A0	-----	ERCA00496A2	ERCA00496A3
	3/4 and 1	20 and 25	GF05737X022	-----	GF05737X042	GF05737X052

\*Recommended Spare Part  
1. Only one metal diaphragm is needed for Types MR98L and MR98LD with 1/4 NPT body size and 2 to 7 psi / 0.14 to 0.48 bar spring range.

Monel® is a mark owned by Special Metals Corporation.  
Hastelloy® C is a mark owned by Haynes International, Inc.

# MR98 Series

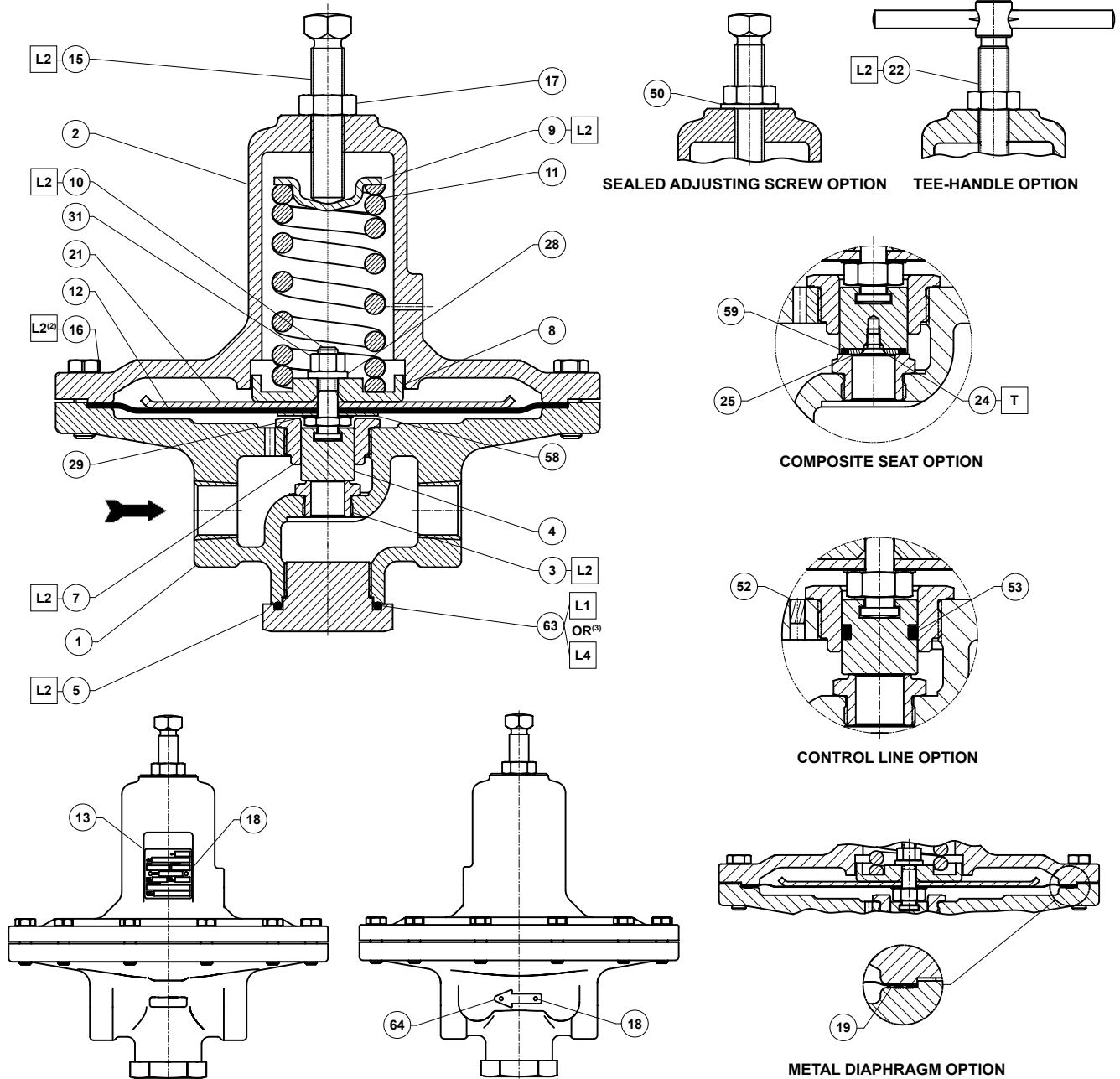

GF04917

**APPLY<sup>(1)</sup>:**

**T = THREAD LOCKER**

**L1 = GENERAL PURPOSE PTFE OR LITHIUM GREASE FOR O-RINGS**

**L2 = ANTI - SEIZE COMPOUND**

**L4 = GRAPHITE SEALANT FOR GRAPHITE RING**

1. Lubricants and sealants must be selected such that they meet the temperature requirements.
2. Apply L2 (anti-seize compound) on key 16 for stainless steel bolts.
3. Apply L4 (graphite sealant) instead of L1 (general purpose PTFE or lithium grease) on key 63 for graphite ring.

**Figure 4. Type MR98L Assembly**

# MR98 Series

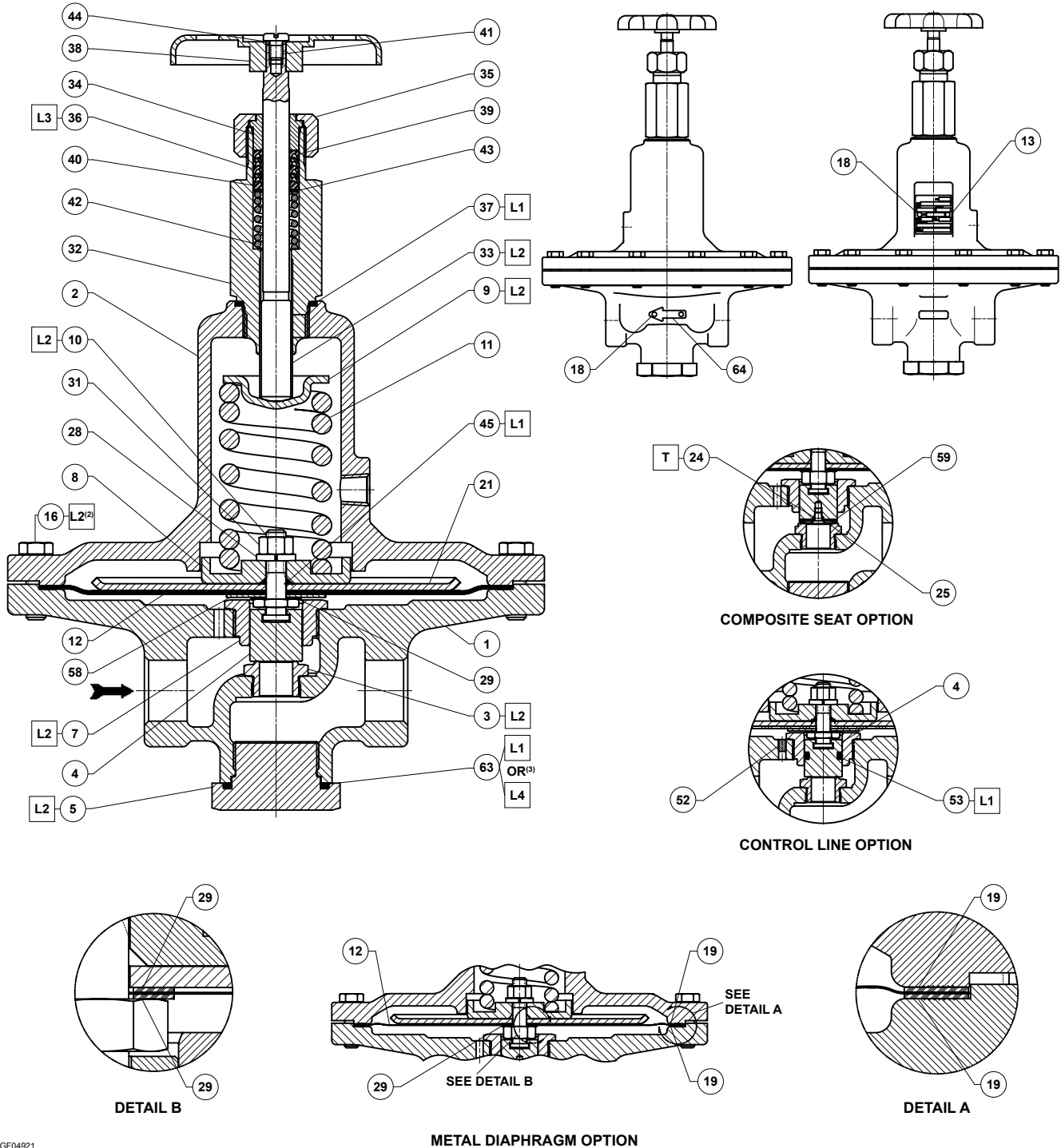

GF04921

□ APPLY<sup>(1)</sup>:

T = THREAD LOCKER

L1 = GENERAL PURPOSE PTFE OR LITHIUM GREASE FOR O-RINGS

L2 = ANTI - SEIZE COMPOUND

L3 = SILICONE GREASE

L4 = GRAPHITE SEALANT FOR GRAPHITE RING

1. Lubricants and sealants must be selected such that they meet the temperature requirements.

2. Apply L2 (anti-seize compound) on key 16 for stainless steel bolts.

3. Apply L4 (graphite sealant) instead of L1 (general purpose PTFE or lithium grease) on key 63 for graphite ring.

Figure 5. Type MR98LD Assembly

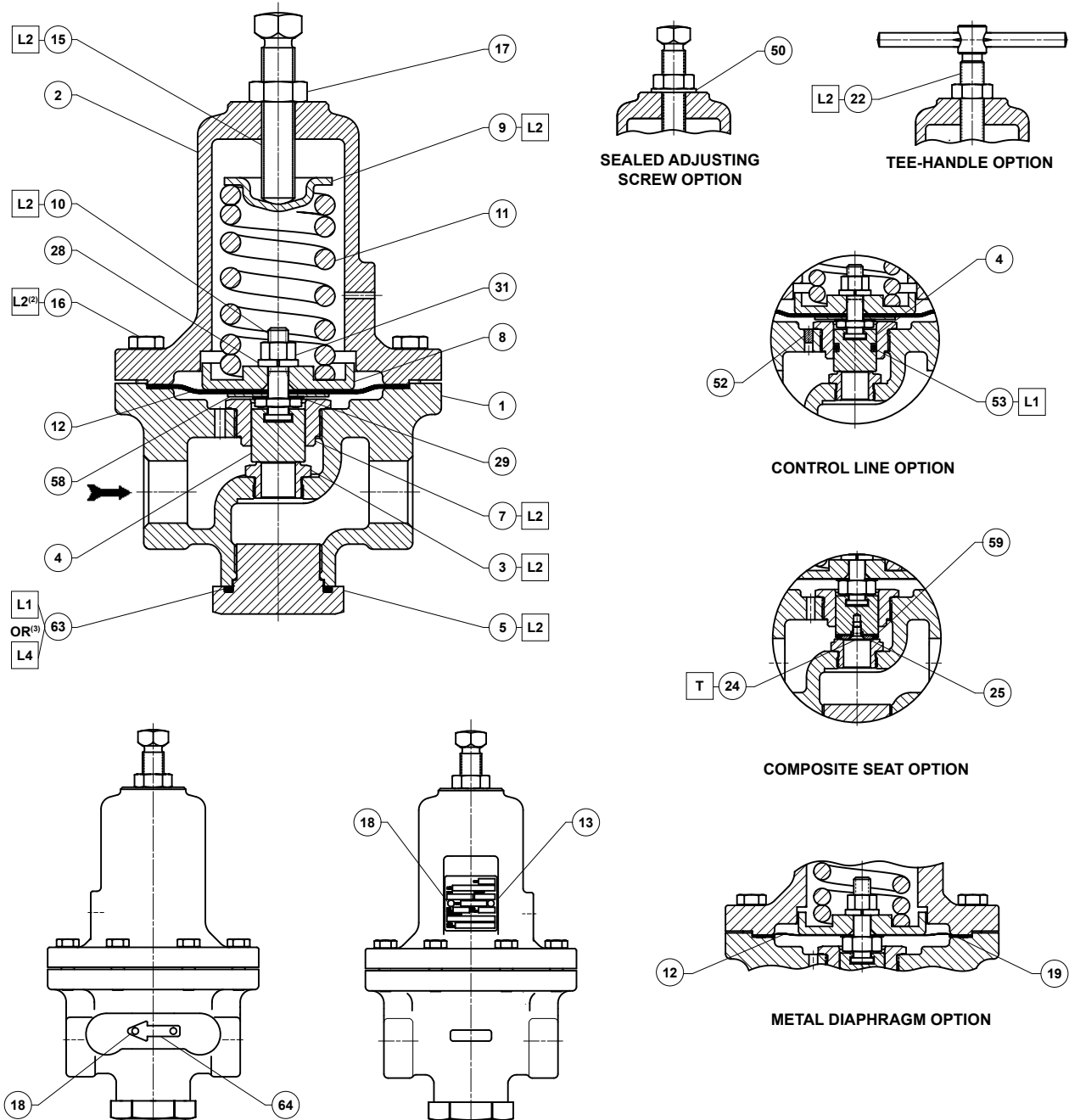

GF04916

□ APPLY<sup>(1)</sup>:

T = THREAD LOCKER

L1 = GENERAL PURPOSE PTFE OR LITHIUM GREASE FOR O-RINGS

L2 = ANTI - SEIZE COMPOUND

L4 = GRAPHITE SEALANT FOR GRAPHITE RING

1. Lubricants and sealants must be selected such that they meet the temperature requirements.

2. Apply L2 (anti-seize compound) on key 16 for stainless steel bolts.

3. Apply L4 (graphite sealant) instead of L1 (general purpose PTFE or lithium grease) on key 63 for graphite ring.

Figure 6. Type MR98H Assembly with 1/4 NPT to 1 in. / DN 25 Body Sizes

# MR98 Series

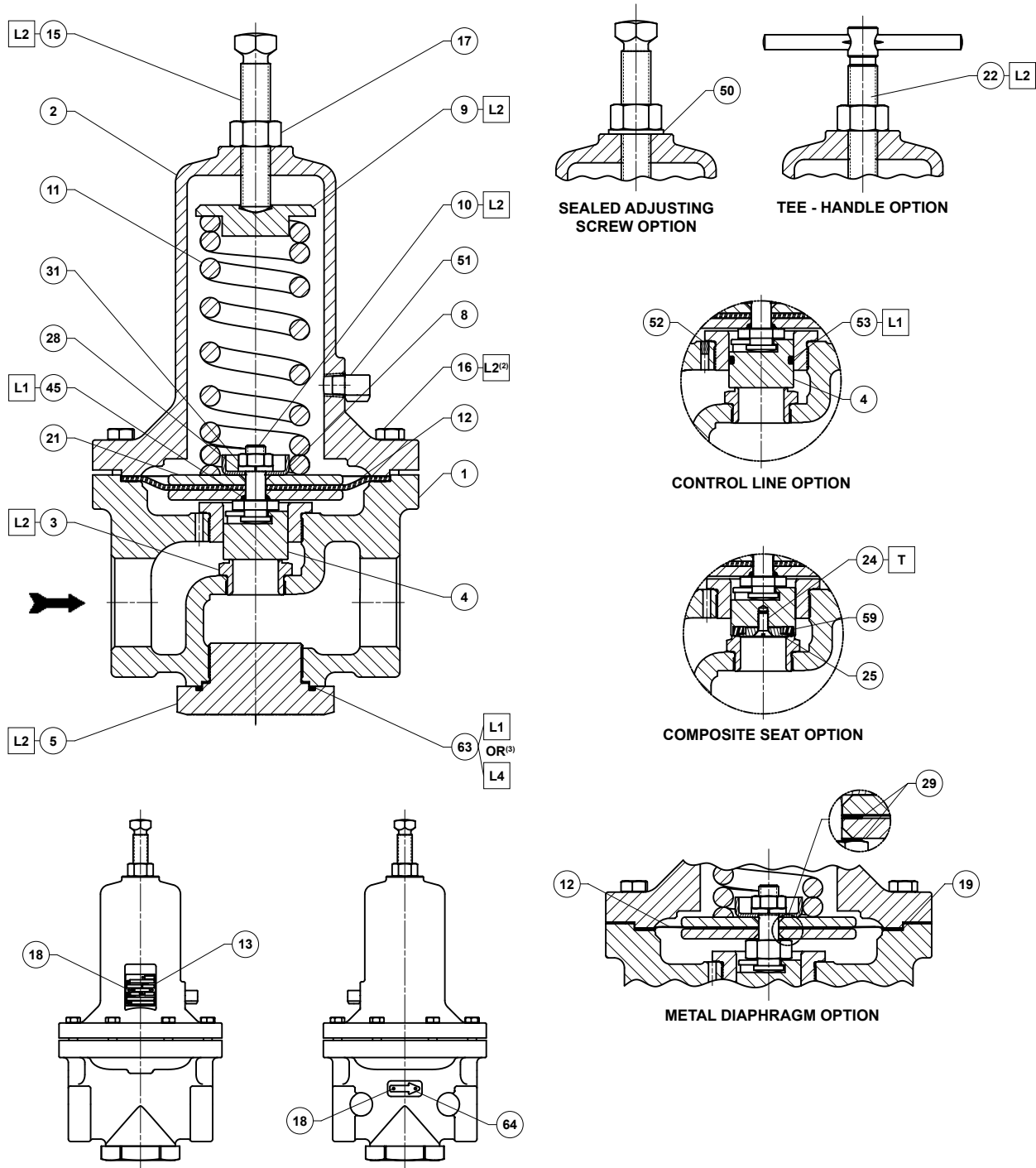

ERAA03248

**APPLY<sup>(1)</sup>:**

T = THREAD LOCKER

L1 = GENERAL PURPOSE PTFE OR LITHIUM GREASE FOR O-RINGS

L2 = ANTI - SEIZE COMPOUND

L4 = GRAPHITE SEALANT FOR GRAPHITE RING

1. Lubricants and sealants must be selected such that they meet the temperature requirements.

2. Apply L2 (anti-seize compound) on key 16 for stainless steel bolts.

3. Apply L4 (graphite sealant) instead of L1 (general purpose PTFE or lithium grease) on key 63 for graphite ring.

**Figure 7. Type MR98H Assembly with 1-1/2 to 2 in. / DN 40 to 50 Body Sizes**



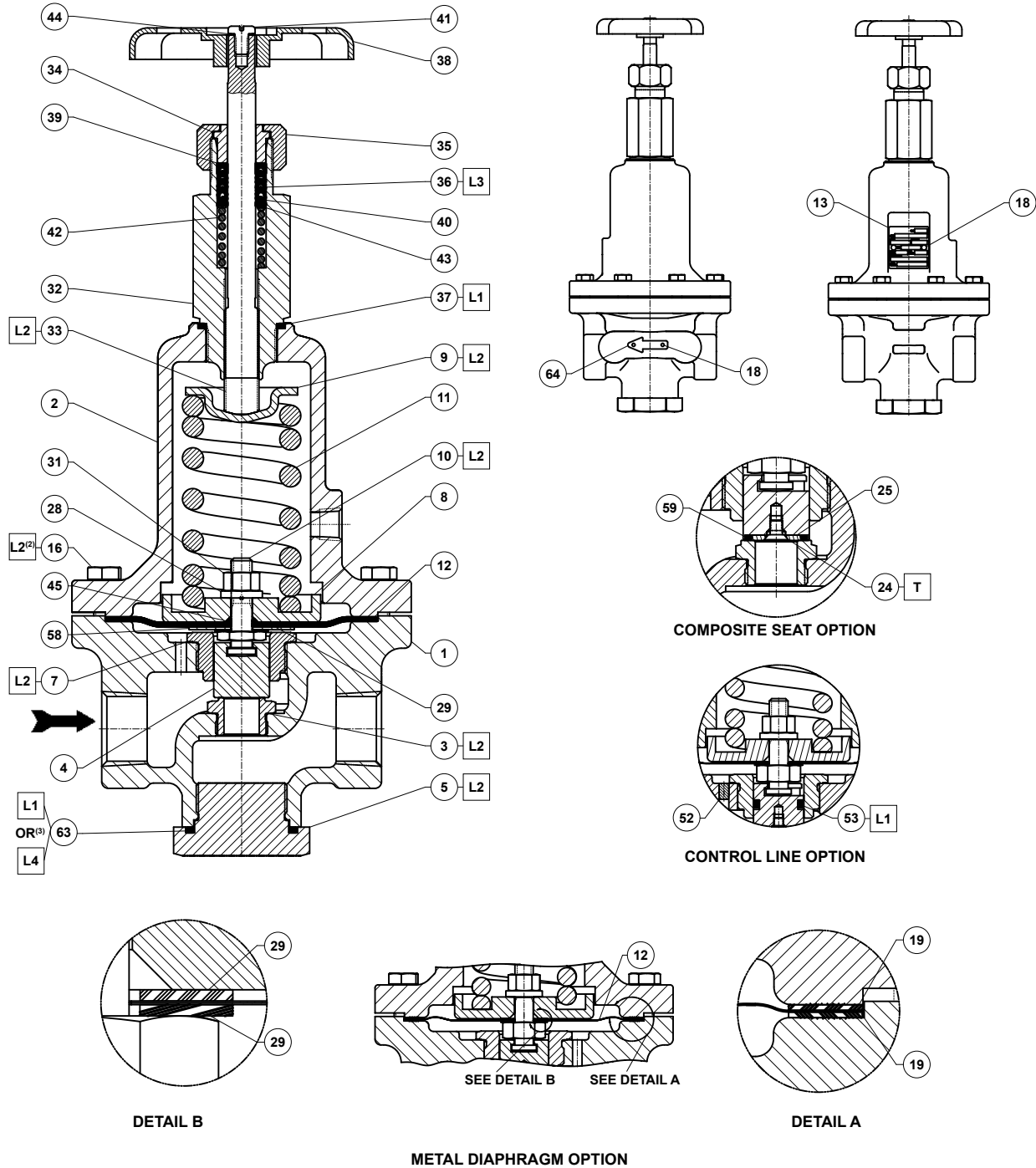

GF04920

**APPLY<sup>(1)</sup>:**

- T = THREAD LOCKER
- L1 = GENERAL PURPOSE PTFE OR LITHIUM GREASE FOR O-RINGS
- L2 = ANTI - SEIZE COMPOUND
- L3 = SILICONE GREASE
- L4 = GRAPHITE SEALANT FOR GRAPHITE RING

1. Lubricants and sealants must be selected such that they meet the temperature requirements.
2. Apply L2 (anti-seize compound) on key 16 for stainless steel bolts.
3. Apply L4 (graphite sealant) instead of L1 (general purpose PTFE or lithium grease) on key 63 for graphite ring.

**Figure 8. Type MR98HD Assembly with 1/4 NPT to 1 in. / DN 25 Body Sizes**

# MR98 Series

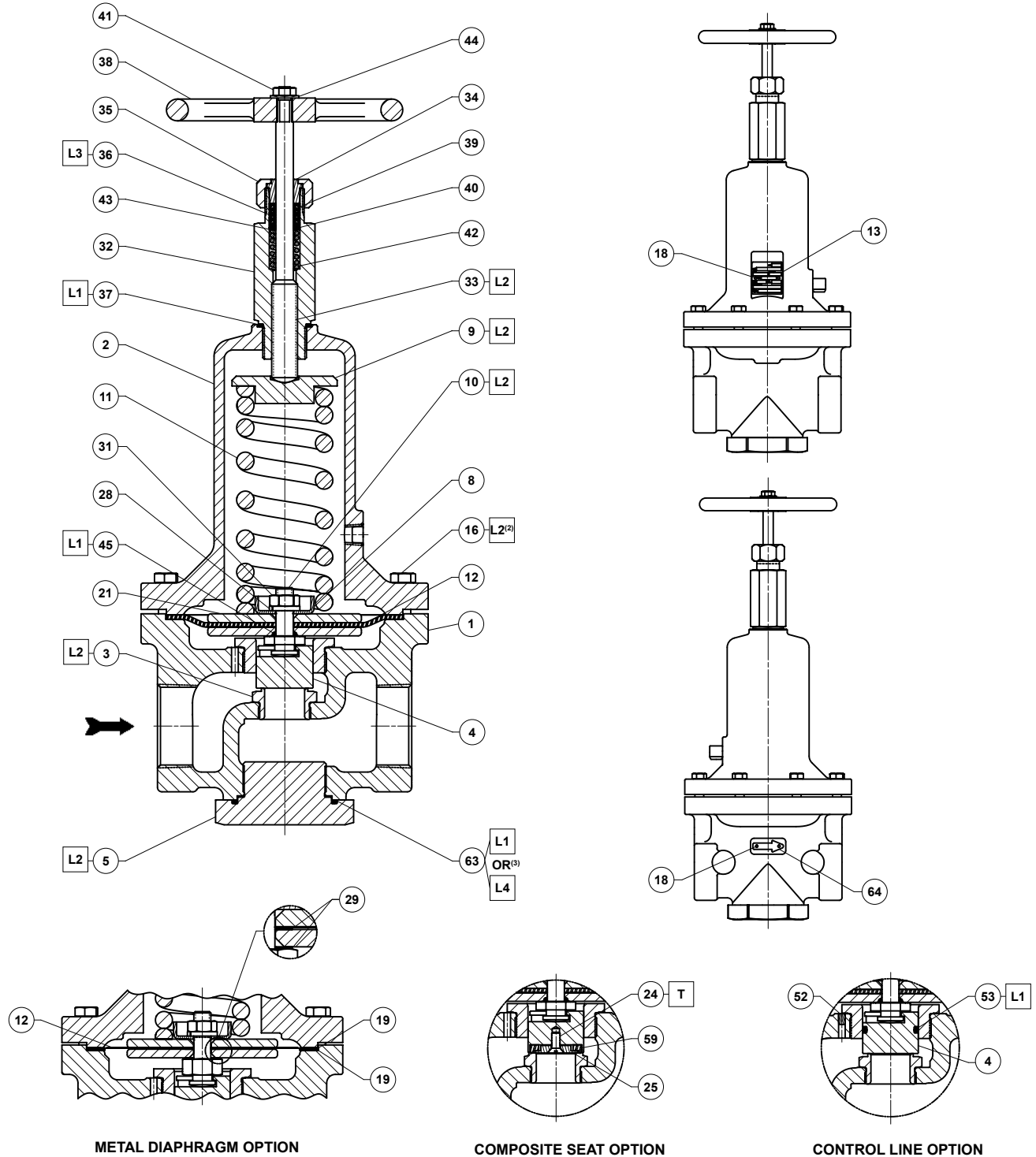

ERAA03271

- APPLY<sup>(1)</sup>:
- T = THREAD LOCKER
  - L1 = GENERAL PURPOSE PTFE OR LITHIUM GREASE FOR O-RINGS
  - L3 = SILICONE GREASE
  - L2 = ANTI - SEIZE COMPOUND
  - L4 = GRAPHITE SEALANT FOR GRAPHITE RING

1. Lubricants and sealants must be selected such that they meet the temperature requirements.
2. Apply L2 (anti-seize compound) on key 16 only for stainless steel bolts.
3. Apply L4 (graphite sealant) instead of L1 (general purpose PTFE or lithium grease) on key 63 for graphite ring.

**Figure 9. Type MR98HD Assembly with 1-1/2 to 2 in. / DN 40 to 50 Body Sizes**

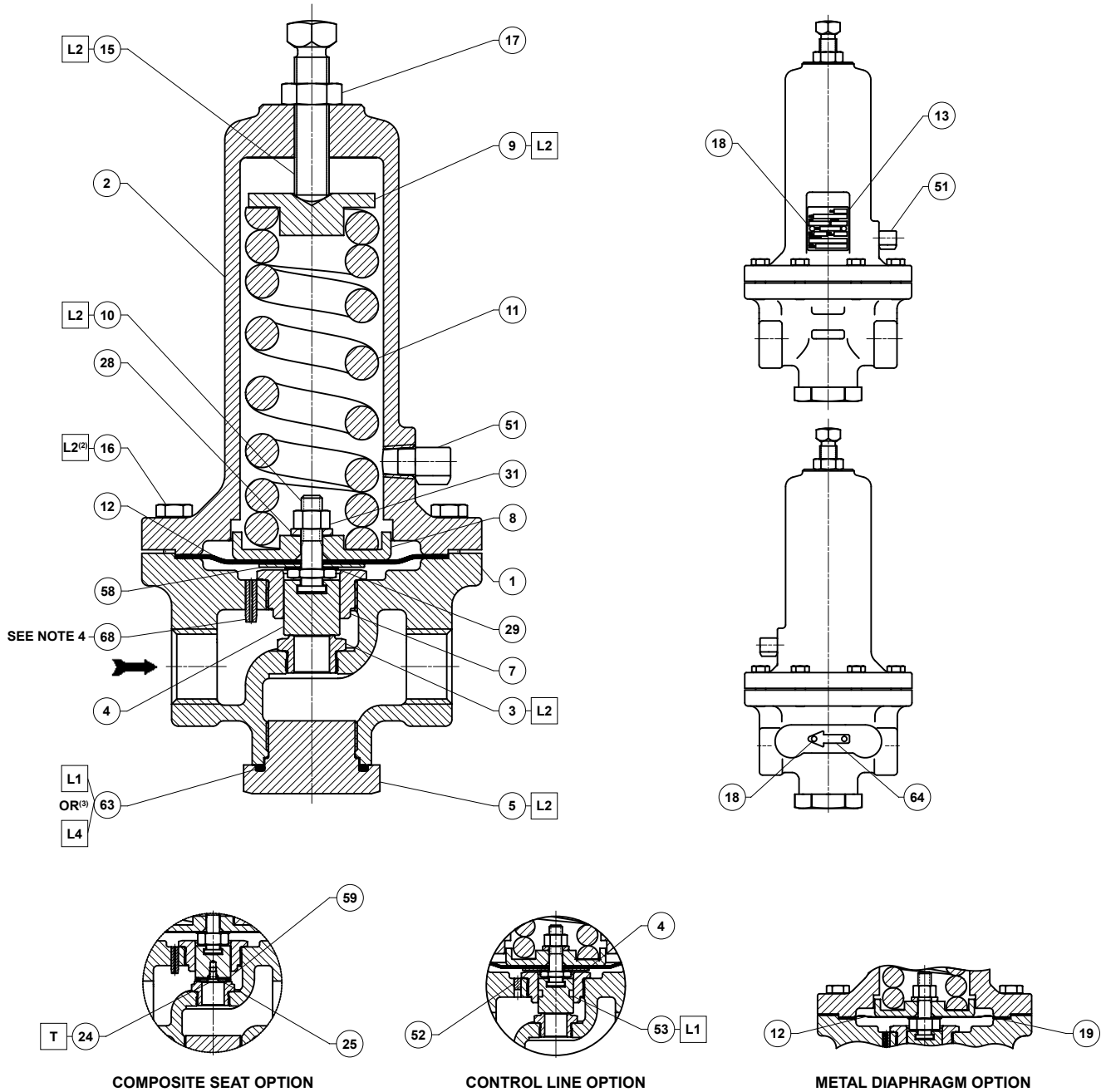

ERCA00605

- APPLY<sup>(1)</sup>:**  
**T = THREAD LOCKER**  
**L1 = GENERAL PURPOSE PTFE OR LITHIUM GREASE FOR O-RINGS**  
**L2 = ANTI - SEIZE COMPOUND**  
**L4 = GRAPHITE SEALANT FOR GRAPHITE RING**

1. Lubricants and sealants must be selected such that they meet the temperature requirements.
2. Apply L2 (anti-seize compound) on key 16 only for stainless steel bolts.
3. Apply L4 (graphite sealant) instead of L1 (general purpose PTFE or lithium grease) on key 63 for graphite ring.
4. Key 68 is available for Type MR98HH with 3/4 and 1 in. / DN 20 and 25 bodies only.

**Figure 10. Type MR98HH Assembly with 1/4 NPT to 1 in. / DN 25 Body Sizes**

# MR98 Series

---

## Industrial Regulators

### Emerson Process Management Regulator Technologies, Inc.

USA - Headquarters  
McKinney, Texas 75070 USA  
Tel: +1 800 558 5853  
Outside U.S. +1 972 548 3574

Asia-Pacific  
Shanghai 201206, China  
Tel: +86 21 2892 9000

Europe  
Bologna 40013, Italy  
Tel: +39 051 419 0611

Middle East and Africa  
Dubai, United Arab Emirates  
Tel: +971 4811 8100

## Natural Gas Technologies

### Emerson Process Management Regulator Technologies, Inc.

USA - Headquarters  
McKinney, Texas 75070 USA  
Tel: +1 800 558 5853  
Outside U.S. +1 972 548 3574

Asia-Pacific  
Singapore 128461, Singapore  
Tel: +65 6770 8337

Europe  
Bologna 40013, Italy  
Tel: +39 051 419 0611  
Chartres 28008, France  
Tel: +33 2 37 33 47 00

Middle East and Africa  
Dubai, United Arab Emirates  
Tel: +971 4811 8100

## TESCOM

### Emerson Process Management Tescom Corporation

USA - Headquarters  
Elk River, Minnesota 55330-2445, USA  
Tels: +1 763 241 3238  
+1 800 447 1250

Europe  
Selmsdorf 23923, Germany  
Tel: +49 38823 31 287

Asia-Pacific  
Shanghai 201206, China  
Tel: +86 21 2892 9499



The distinctive diamond shape cast into every spring case uniquely identifies the regulator as part of the Fisher® brand and assures you of the highest-quality engineering, durability, performance, and support.

For further information visit [www.fisherregulators.com](http://www.fisherregulators.com)

The Emerson logo is a trademark and service mark of Emerson Electric Co. All other marks are the property of their prospective owners. Fisher is a mark owned by Fisher Controls International LLC, a business of Emerson Process Management.

*The contents of this publication are presented for informational purposes only, and while every effort has been made to ensure their accuracy, they are not to be construed as warranties or guarantees, express or implied, regarding the products or services described herein or their use or applicability. We reserve the right to modify or improve the designs or specifications of such products at any time without notice.*

Emerson Process Management Regulator Technologies, Inc. does not assume responsibility for the selection, use or maintenance of any product. Responsibility for proper selection, use and maintenance of any Emerson Process Management Regulator Technologies, Inc. product remains solely with the purchaser.