

OPERATION

NOTE: Fan control knob turns fan on at maximum speed to assist motor start-up. Fan speed decreases with clockwise rotation.

Set the fans on their HIGH speed pull chain settings. Then use your speed control to select any of the 3-speeds, plus OFF.

NOTE: Fully counter-clockwise is OFF. The three fan speeds are selected by rotating the knob one position at a time clockwise.

IMPORTANT

Always have the fan switch set to HIGH speed before using the wall control. To avoid accidental pull chain use, shorten chain by cutting it 1" below switch body.

The SW93 Quietset Dual Fan Control turns any set of two Emerson CF Series Ceiling Fans into three-speed fans.

CAUTION: Read all instructions carefully before installation. Save this Owner's Manual for future reference.

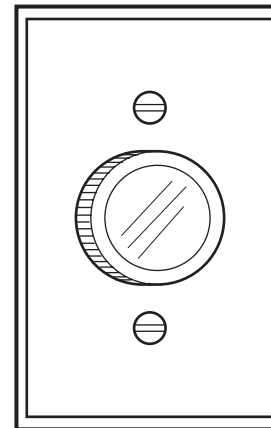

Model No.

SW93

WHITE/IVORY

QUIETSET DUAL FAN CONTROL

SINGLE-POLE, 3-SPEED FAN MOTOR CONTROL

MAXIMUM 3.0 AMP, 120VAC, 60HZ

LIMITED WARRANTY

What The Warranty Covers:

All products covered by this Owner's Manual are warranted against all defects in workmanship and materials. You must be the original purchaser or user of the product to be covered.

What The Period Of Coverage Is:

All components are covered by this warranty for one year from the date you purchased your fan control. ANY IMPLIED WARRANTY OF MERCHANTABILITY OR FITNESS FOR A PARTICULAR PURPOSE, MADE WITH RESPECT TO COMPONENTS AND ACCESSORIES IS ALSO LIMITED TO ONE YEAR.

What Will Emerson Company Do To Correct Problems:

Emerson Company will replace a defective Emerson Fan Control at no charge to you. We will ship the repaired product or replacement to you at no charge, but you are responsible for all costs or removal, reinstallation and shipping of the product to Emerson.

How Can You Get Service:

YOU MUST HAVE PROOF OF YOUR PURCHASE OF THE FAN CONTROL TO OBTAIN LIMITED WARRANTY SERVICE. KEEP YOUR RECEIPT OR OTHER PROOF OF PURCHASE. You can return the product to our factory or to your nearest authorized service center.

- To return the product to the factory, obtain a return authorization and service identification tag by writing to Air Comfort Products, Division of Emerson Company, 8100 W. Florissant Ave., St. Louis, MO 63136. Include all model numbers shown on the product with your request.
- To return the product to an authorized service center, call 1-800-654-3545 for the address of the nearest authorized service center. You will be responsible for all insurance, freight or other transportation charges to our factory or authorized service center. Your Emerson Fan Control should be properly packed to avoid damage in transit since we will not be responsible for any such damage.

What Is Not Covered:

This warranty also does not cover any defects, malfunctions or failures caused by:

- Repairs by persons not authorized by Emerson Company,
- Use of parts or accessories not authorized by Emerson Company,
- Mishandling, improper installation, modifications or damage to your wall control while in your possession, or
- Unreasonable use, misuse, abuse, including failing to do reasonable and necessary maintenance, and normal wear and tear.

Additionally, this warranty and any implied warranty of merchantability or fitness for a particular purpose are voided when:

- The original purchaser or user ceases to own the product, or
- The ceiling fan is moved from its original point of installation.

This warranty is only valid within the 50 states of the United States and the District of Columbia. No other written or oral warranties apply, and no employee, agent, dealer or other person is authorized to give any warranties on behalf of Emerson Company.

REPAIR, REPLACEMENT OR A REFUND ARE THE EXCLUSIVE REMEDIES AVAILABLE UNDER THIS WARRANTY AND EMERSON IS NOT RESPONSIBLE FOR DAMAGES OF ANY KIND, INCLUDING INCIDENTAL AND CONSEQUENTIAL DAMAGES. Incidental damages include but are not limited to such damages as loss of time and loss of use. Consequential damages include but are not limited to the cost of repairing or replacing other property which was damaged if this product does not work properly.

How State Law Relates To The Warranty:

Some states do not allow the exclusion or limitation of incidental or consequential damages so the above exclusion or limitation may not apply to you. This warranty gives you specific legal rights, and you may also have other rights which vary from state to state.



EMERSON®
FAN CONTROLS

SW93 Quietset Dual Fan Control Owner's Manual

Safety Instructions

WARNING: To avoid fire, shock, and serious personal injury, follow all instructions carefully.

1. Read your Owner's Manual carefully. Retain Owner's Manual for future reference.
2. To avoid possible electrical shock, be sure electricity is turned off at the main fuse or circuit breaker box before wiring.
3. Make certain no bare wires are exposed outside the wire connectors.
4. Do not mount speed control near heat producing equipment.
5. All wiring must conform to National and Local Electrical Codes. If you do not have enough electrical knowledge, have a licensed electrician install the control.

WARNING: Use of this control with some ceiling fans could result in fire, shock and serious personal injury. Use this speed control only with Emerson CF series ceiling fans.

General

This control is designed to operate two ceiling fans, and not any accessory light kits. This SW93 speed control is rated for 3.0 amps at 120 volts. To avoid erratic speeds and possible damage to your ceiling fan, use this control only with the fans pull chain switches set to their high speed settings.

Installation

1. Before disconnecting power, ensure that the fan is set at the highest speed.

NOTE: Electric connections should be in accordance with the National Electrical Codes and all Local Codes. Before starting, disconnect power to the circuit at the fuse box or circuit breaker panel.

2. Remove the faceplate and screws from the existing wall switch. Pull switch out from wall outlet box.
3. Disconnect wire from existing fan wall switch (Figure 1).

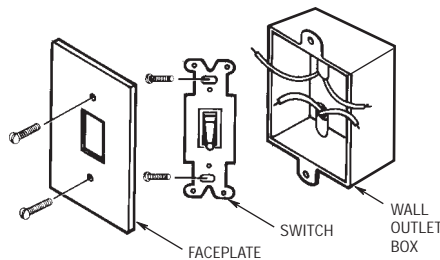

Figure 1

4. Set the SW93 Quietset Dual Fan Control in the off position (full counter-clockwise), and pull off the knob.

5. Connect the BLACK wire from the Quietset to the fan/motor lead with a wire connector (provided). (Figure 2.)

6. Connect the BLACK wire from the Quietset to the 120VAC hot wire with a wire connector (provided).

NOTE: Use wire connectors (supplied) to secure electrical connections.

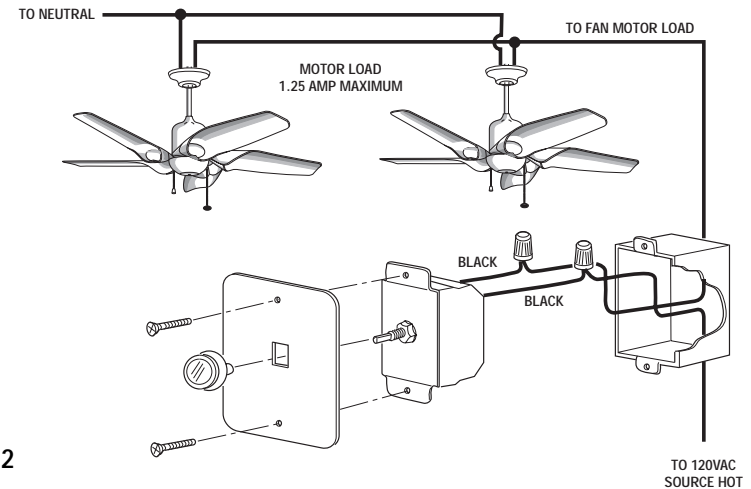

Figure 2

7. Position the faceplate (not provided) onto the speed control. Using the two 6-32 screws supplied with the faceplate, screw the faceplate and speed control to the wall outlet box (Figure 3).

8. Press knob onto the shaft and rotate counter-clockwise to the full-OFF position.
9. Restore power at the main fuse box or circuit breaker panel.

CAUTION

For fans equipped with built-in variable speed devices: These devices must be set at their MAXIMUM SPEED for proper operation. Adjustments to their setting must only be made with Quietset in the OFF position. Changing or switching these settings while the fan control is in operation could damage the control.

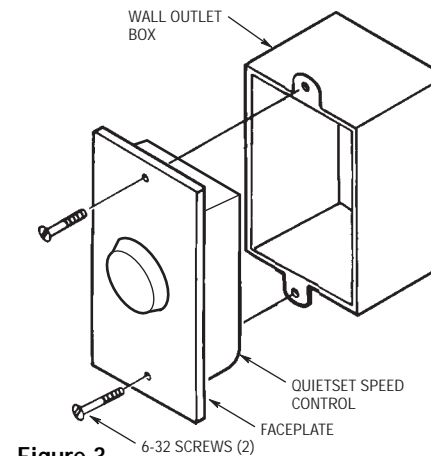

Figure 3