

Type 627F Pilot-Operated Pressure Reducing Regulator

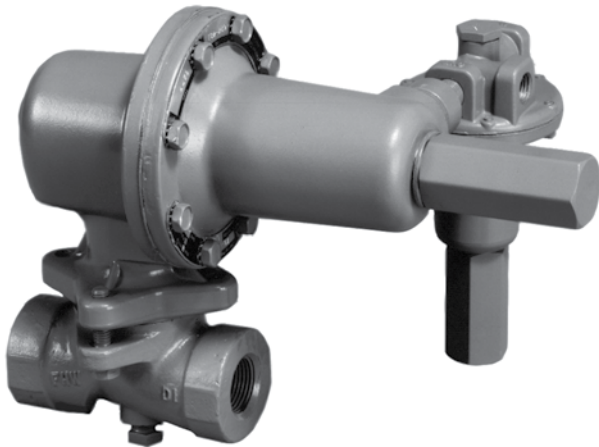

W5607-1

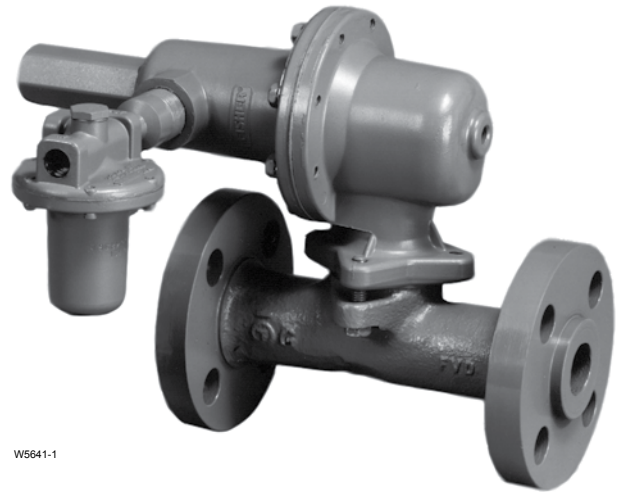

W5641-1

Figure 1. Type 627F Pressure Reducing Regulators

Introduction

The Type 627F pilot-operated (Type 6351F pilot) pressure reducing regulator (Figure 1) provides superior performance when used in pressure-factor measurement (fixed-factor billing) applications. The Type 627F includes a factory-installed Type 6351F pilot and has external registration that requires a downstream control line.

Features

- **Accurate for Pressure-Factor Measurement Applications**—Pilot action controls pressure to within ± 1 percent of the absolute outlet pressure (psia) setting at full valve disk travel, resulting in higher capacity than could be obtained without a pilot. This capability results in low-pressure variations over broad flow ranges and inlet pressure ranges.
- **Easy to Maintain**—Trim parts can be replaced without removing the regulator body from the

pipeline. A two-bolt connection between the body and diaphragm casing simplifies disassembly for maintenance.

- **Installation Adaptability**—The diaphragm case and/or regulator body can be rotated in any of four positions to allow regulator installation in locations with limited space. The regulator may be installed in any position without affecting operation as long as the spring case vent is protected from the elements.
- **Tamper-Resistant**—An adjusting screw locknut and protective cap (Figure 2) is standard on all Type 6351F pilots to discourage tampering with the pressure setting.
- **Wide Range of Flow Capabilities**—A selection of body and orifice sizes is available to satisfy various flow requirements.
- **Tight Shutoff Capability**—A flat-faced disk of Nitrile (NBR) provides excellent shutoff capability.



Bulletin 71.2:627F

Specifications

Body Sizes and End Connection Styles

Ductile iron: 3/4, 1, or 2 NPT

Steel: 3/4, 1, or 2 NPT;

NPS 1 or 2 / DN 25 or 50, CL150 RF,

CL300 RF, CL600 RF, PN 16/25/40 RF

Maximum Inlet and Differential Pressures⁽¹⁾

See Table 2

Minimum Pressure Differential

20 psid / 1.4 bar d

Outlet Pressure Ranges⁽¹⁾

5 to 100 psig / 0.34 to 6.9 bar

See Table 1

Maximum Emergency Outlet Pressure⁽¹⁾

250 psig / 17.2 bar for all Type 627F actuators and Type 6351F pilot components.

Outlet Pressure Accuracy

±1% of absolute pressure setting⁽¹⁾ (psia or bar absolute) when inlet pressure is held within allowable variations shown in Table 3; droop does not exceed 1% of absolute pressure setting for flow rates shown in Tables 6 through 8.

Flow Coefficients

See Table 4

IEC Sizing Coefficients

See Table 5

Typical Regulating Capacities

See Tables 6 through 8 and Capacity Information section

Typical Performance Curve

See Figure 3

Construction Materials

Type 627F Main Regulator

Body: Ductile iron (**standard**) or steel

Spring Case and Diaphragm Case: Die cast Aluminum (**standard**), Ductile iron, or Steel

Orifice: Aluminum (**standard**) or Stainless steel

Construction Materials (continued)

Disk Assembly: Aluminum (**standard**) or

Stainless steel holder with Nitrile (NBR) disk

O-Rings and Diaphragm: Nitrile (NBR)

Tension Spring: Plated steel

Type 6351F Pilot

Body: Stainless steel

Spring Case: Aluminum

Diaphragm: Nylon fabric coated with Nitrile (NBR)

Inner Valve Plug: Stainless steel/Nitrile (NBR) or

Stainless steel/Fluorocarbon (FKM)

Stem: Stainless steel

Control Spring: Zinc-plated steel

Valve Spring: Stainless steel

Pusher Post: Aluminum or Stainless steel

Diaphragm Plate, Lower Spring Guide, and

Adjusting Screw: Zinc-plated steel

Temperature Capabilities⁽¹⁾

-20 to 180°F / -29 to 82°C

Pressure Registration

External through 1/4 NPT (internal) control line connection (see Figure 2)

Pilot Spring Case Vent Connection

1/4 NPT (internal) with removable screened vent assembly

Pilot Connections

1/4 NPT (internal)

Approximate Weights

NPT body with Ductile Iron or Steel Casings:

10 pounds / 4.5 kg

NPT body with Aluminum Casings:

6.3 pounds / 2.9 kg

Flanged body with Steel Casings:

18 pounds / 8.2 kg

Flanged body with Ductile Iron Casings:

14 pounds / 6.4 kg

External Dimensions

See Figure 4

1. The pressure/temperature limits in this Bulletin and any applicable standard or code limitation should not be exceeded.

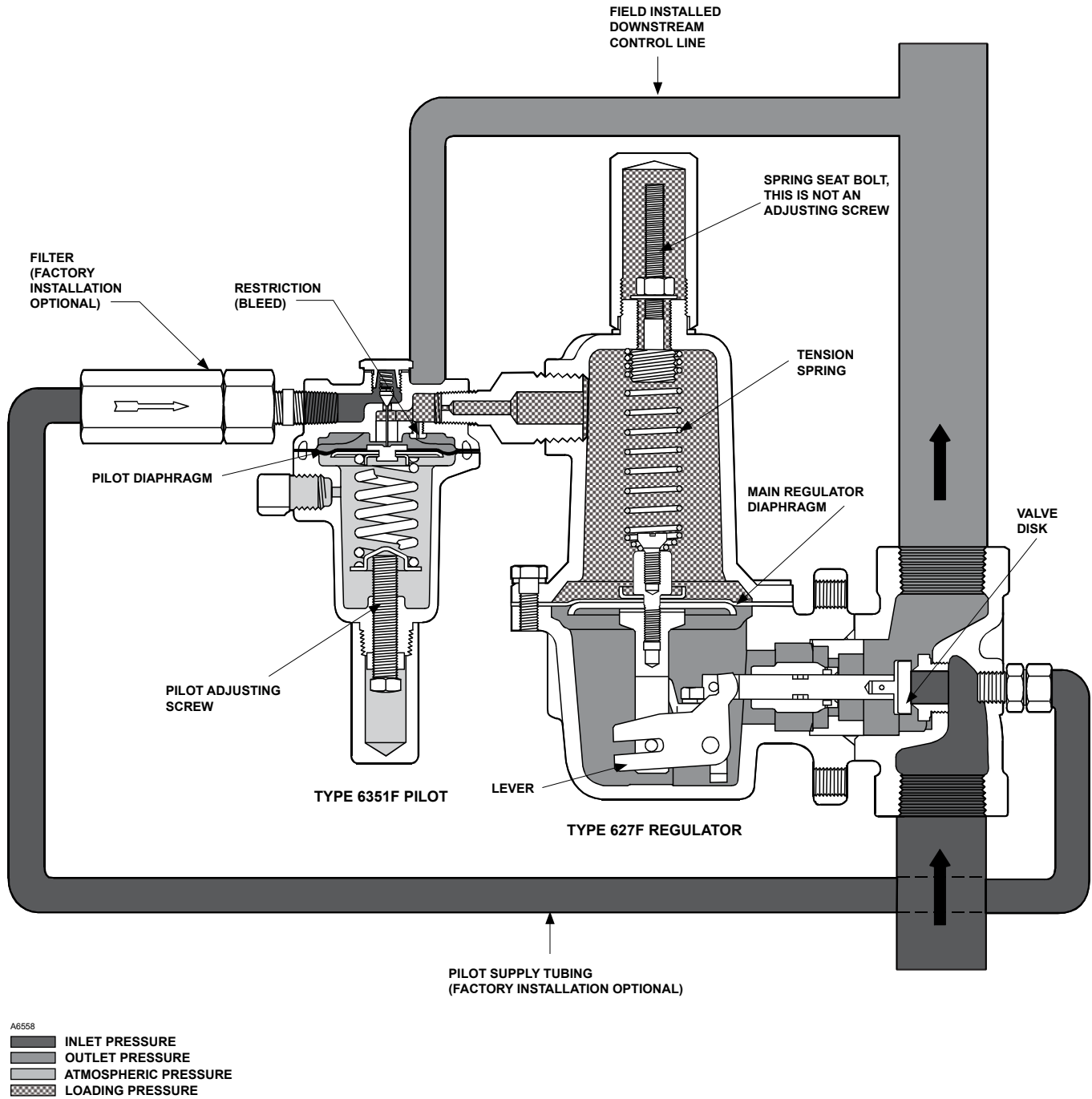

Figure 2. Type 627F Pilot-Operated Pressure Reducing Regulator Operational Schematic

Bulletin 71.2:627F

Table 1. Outlet Pressure Ranges

PILOT TYPE	OUTLET PRESSURE RANGE		PILOT CONTROL SPRING INFORMATION					
			Part Number	Color Code	Wire Diameter		Free Length	
	psig	bar			Inches	mm	Inches	mm
6351F	5 to 35	0.34 to 2.4	1B788327022 1K748527022	Unpainted Red	0.142	3.61	2.13	54.1
	35 to 100	2.4 to 6.9			0.192	4.88	2.19	55.6

Table 2. Maximum Allowable Inlet Pressures and Pressure Differential

ORIFICE SIZE		MAXIMUM INLET PRESSURE		MAXIMUM PRESSURE DIFFERENTIAL	
Inches	mm	psig	bar	psi	bar
3/8 x 1/8	9.5 x 3.2	250	17.2	250	17.2
3/8 x 1/4	9.5 x 6.4	250	17.2	250	17.2
3/8	9.5	250	17.2	250	17.2
1/2	13	125	8.6	125	8.6

Table 3. Additional Specifications

ORIFICE SIZE		ALLOWABLE INLET PRESSURE RANGE FOR MAINTAINING OUTLET PRESSURE WITHIN ±1% OF THE ABSOLUTE OUTLET PRESSURE SETTING ⁽¹⁾									
		5 psig / 0.34 bar		30 psig / 2.1 bar		40 psig / 2.8 bar		60 psig / 4.1 bar		100 psig / 6.9 bar	
Inches	mm	psig	bar	psig	bar	psig	bar	psig	bar	psig	bar
3/8 x 1/8	9.5 x 3.2	30 to 250	2.1 to 17.2	55 to 250	3.8 to 17.2	65 to 250	4.5 to 17.2	85 to 250	5.9 to 17.2	125 to 250	8.6 to 17.2
3/8 x 1/4	9.5 x 6.4	30 to 250	2.1 to 17.2	55 to 250	3.8 to 17.2	65 to 250	4.5 to 17.2	85 to 250	5.9 to 17.2	125 to 250	8.6 to 17.2
3/8	9.5	30 to 250	2.1 to 17.2	55 to 250	3.8 to 17.2	65 to 250	4.5 to 17.2	85 to 250	5.9 to 17.2	125 to 250	8.6 to 17.2
1/2	13	25 to 125	1.7 to 8.6	50 to 125	3.4 to 8.6	60 to 125	4.1 to 8.6	80 to 125	5.5 to 8.6	120 to 125	8.3 to 8.6

1. For best performance, outlet pressure setting should be made using an inlet pressure that is midway between the highest and lowest expected inlet pressure.

Table 4. Flow Coefficients

ORIFICE SIZE		3/4 NPT BODY			NPS 1 / DN 25 BODY			NPS 2 / DN 50 BODY		
		Wide-Open	Wide-Open	C ₁	Wide-Open	Wide-Open	C ₁	Wide-Open	Wide-Open	C ₁
Inches	mm	C _g	C _v		C _g	C _v		C _g	C _v	
3/8 x 1/8	9.5 x 3.2	12.5	0.43	29.1	12.5	0.43	29.4	12.5	0.43	29.2
3/8 x 1/4	9.5 x 6.4	50	1.63	30.6	50	1.71	29.3	52	1.66	31.3
3/8	9.5	108	2.99	36.1	108	3.42	31.6	115	3.39	33.9
1/2	13	190	4.87	39.0	190	5.29	35.9	200	5.01	39.9

Table 5. IEC Sizing Coefficients

ORIFICE SIZE		X _T			F _D	F _L
Inches	mm	3/4 NPT body	NPS 1 / DN 25 body	NPS 2 / DN 50 body		
1/8	3.2	0.54	0.55	0.54	0.50	0.79
1/4	6.4	0.59	0.54	0.62		0.87
3/8	9.5	0.82	0.63	0.73		0.89
1/2	13	0.96	0.82	1.01		0.86

Principle Operation

The superior performance of a Type 627F regulator is due to the amplifying effect of the pilot and the two-path control system (Figure 2). Changes in outlet pressure act quickly on the main regulator diaphragm which repositions the valve disk to provide fast response to system changes. Simultaneously, the pilot amplifies system pressure changes to position the main regulator valve disk for precise pressure control.

Inlet pressure is used for the pilot supply pressure. If downstream flow increases, lowering the outlet pressure below the regulator setpoint, pressure on the pilot diaphragm and the lever side of the main regulator diaphragm decreases. The pilot opens to supply the required loading pressure increase. The increased loading pressure from the pilot overcomes the main regulator spring force, and the main regulator valve disk moves farther open to supply the required flow. When downstream pressure increases due to lowered demand, greater pressure is registered on the pilot diaphragm and the lever side of the main regulator diaphragm. The pilot closes, and the excess loading pressure bleeds off to downstream, through the pilot restriction. With the lower loading pressure, the spring can move the main regulator disk closer to the orifice.

Under no flow conditions, the excess loading pressure bleeds through the pilot restriction to the downstream system until the loading pressure and outlet pressure equalize. The main valve is closed by the spring and the bleed stops.

Installation

The Type 627F regulators may be installed in any position, as long as flow will be in the same direction as that indicated by the body arrow. These regulators should be installed so that their spring case vents are protected from anything that might clog them.

Emerson™ provides an instruction manual with every regulator shipped. Refer to this for complete installation, operation, and maintenance instructions. Included is a complete listing of individual parts and recommended spare parts.

Overpressure Protection

Overpressurizing any portion of a regulator or associated equipment may cause personal injury, leakage, or property damage due to bursting of pressure-containing parts or explosion of accumulated gas.

To avoid overpressure, provide appropriate pressure relieving or pressure limiting devices to ensure that none of the limits in the specifications section is exceeded. Regulator operation within ratings does not prevent the possibility of damage from external sources such as debris in the pipeline. Inspect the regulator for damage after any overpressure condition.

Refer to the relief sizing coefficients in the specifications table and the Capacity Information section to determine the required external relief valve capacity.

Capacity Information

Natural gas regulating capacities at selected inlet pressures and outlet pressure settings are given in Tables 6 through 8. Flows are in SCFH (60°F and 14.7 psia) of 0.6 specific gravity natural gas. To determine the equivalent capacities for other gases, multiply the table capacity by the following appropriate conversion factor: 0.775 for air, 0.789 for nitrogen, 0.625 for propane, or 0.548 for butane. For gases of other specific gravities, multiply the given capacity by 0.775, and divide by the square root of the appropriate specific gravity.

Then, if capacity is desired in normal cubic meters per hour (Nm³/h) at 0°C and 1.01325 bar, multiply SCFH by 0.0268.

To determine wide-open flow capacities for relief sizing use the following formula:

$$Q = \sqrt{\frac{520}{GT}} C_g P_1 \text{SIN} \left(\frac{3417}{C_1} \sqrt{\frac{\Delta P}{P_1}} \right) \text{DEG}$$

where,

- C_1 = C_g/C_v (see Specifications table)
- C_g = Gas sizing coefficient (see Specifications table)
- G = Gas specific gravity (air = 1.0)
- P_1 = Valve inlet pressure, psia
- ΔP = Pressure drop across valve, psi
- Q = Gas flow rate, SCFH
- T = Absolute temperature of gas at inlet, °Rankine

To obtain the published capacities, the inlet and outlet piping should be the same as the regulator size.

Bulletin 71.2:627F

Table 6. Flow Capacities in SCFH / Nm³/h of 0.6 Specific Gravity Natural Gas at 1% Droop in Absolute Outlet Pressure for 3/4 NPT (Downstream Control Line in Body Size Piping)

PILOT SPRING RANGE, PART NUMBER, AND COLOR CODE	OUTLET PRESSURE SETTING		INLET PRESSURE		3/4 NPT BODY SIZE							
					Orifice Diameter, Inches / mm							
	psig	bar	psig	bar	3/8 x 1/8 / 9.5 x 3.2	3/8 x 1/4 / 9.5 x 6.4	3/8 / 9.5	1/2 / 13				
5 to 35 psig / 0.34 to 2.4 bar 1B788327022 Silver	5	0.34	30	2.1	700	18.8	2840	76.1	5780	155	9730	261
			40	2.8	860	23.1	3500	93.8	7480	200	13,100	351
			50	3.5	1020	27.3	4140	111	8850	237	15,400	413
			60	4.1	1170	31.4	4780	128	10,200	273	15,500	415
			80	5.5	1490	39.9	6060	162	12,900	346	15,500	415
			100	6.9	1800	48.2	7340	197	15,000	415	15,500	415
			125	8.6	2200	59.0	8940	240	15,500	415	15,500	415
			150	10.3	2580	69.1	10,500	281	15,500	415		
	200	13.8	3370	90.3	13,700	367	15,500	415				
	250	17.2	4170	112	15,500	415	15,500	415				
	10	0.69	30	2.1	690	18.5	2760	74.0	5480	147	8500	228
			40	2.8	860	23.1	3500	93.8	7480	200	13,100	351
			50	3.5	1020	27.3	4140	111	8850	237	15,400	413
			60	4.1	1170	31.4	4780	128	10,200	273	17,800	477
			80	5.5	1490	39.9	6060	192	12,900	346	19,500	523
			100	6.9	1800	48.2	7340	197	15,700	421	19,500	523
			125	8.6	2200	59.0	8940	240	17,500	469	19,500	523
			150	10.3	2580	69.1	10,500	281	19,500	523		
	200	13.8	3370	90.3	13,700	367	19,500	523				
	250	17.2	4170	112	16,900	453	19,500	523				
	20	1.4	30	2.1	590	15.8	2310	61.9	4360	117	6000	161
			40	2.8	820	22.0	3250	87.1	6320	169	10,000	268
			50	3.5	1000	26.8	4030	108	8010	215	13,400	359
			60	4.1	1170	31.4	4780	128	10,200	273	17,800	477
			80	5.5	1490	39.9	6060	162	12,900	346	22,600	606
			100	6.9	1800	48.2	7340	197	15,700	421	24,000	634
			125	8.6	2200	59.0	8940	240	19,100	512	28,000	750
			150	10.3	2580	69.1	10,500	281	22,500	603		
200	13.8	3370	90.3	13,700	367	28,000	750					
250	17.2	4170	112	16,900	453	28,000	750					
30	2.1	50	3.5	930	24.9	3680	98.6	7090	190	11,000	295	
		60	4.1	1140	30.6	4530	121	8880	238	14,800	397	
		80	5.5	1490	39.9	6060	162	12,900	346	22,600	606	
		100	6.9	1800	48.2	7340	197	15,700	421	27,400	734	
		125	8.6	2200	59.0	8940	240	19,100	512	33,300	892	
		150	10.3	2580	69.1	10,500	281	22,500	603			
		200	13.8	3370	90.3	13,700	367	28,000	750			
		250	17.2	4170	112	16,900	453	28,000	750			
35 to 100 psig / 2.4 to 6.9 bar 1K748527202 Red	40	2.8	60	4.1	1030	27.6	4070	109	7770	208	10,400	279
			80	5.5	1450	38.9	5790	155	11,400	306	19,000	509
			100	6.9	1790	48.0	7340	197	15,700	421	27,400	734
			125	8.6	2200	59.0	8940	240	19,100	512	33,300	892
			150	10.3	2580	69.1	10,400	279	20,000	536		
	200	13.8	3370	90.3	13,500	362	20,000	536				
	250	17.2	4170	112	16,900	453	20,000	536				
	50	3.5	60	4.1	820	22.0	3210	86.0	5970	160	7500	201
			70	4.8	1130	30.3	4450	119	8430	226	10,600	284
			80	5.5	1370	36.7	5420	145	10,500	281	17,000	456
			100	6.9	1770	47.4	7060	189	14,000	375	23,300	624
			125	8.6	2200	59.0	8940	240	19,100	512	33,300	892
	150	10.3	2590	69.4	10,400	279	22,500	603				
	200	13.8	3370	90.3	13,500	362	29,000	777				
	250	17.2	4170	112	16,900	453	29,000	777				
	60	4.1	80	5.5	1220	32.7	4790	128	9050	243	12,000	322
			100	6.9	1700	45.6	6730	180	13,100	351	21,600	579
			125	8.6	2170	58.2	8700	233	17,300	464	28,400	761
			150	10.3	2580	69.1	10,300	276	22,500	603		
			200	13.8	3370	90.3	13,500	362	29,400	788		
250	17.2	4170	112	16,900	453	32,000	858					
75	5.2	100	6.9	1490	39.9	5870	157	11,100	297	17,000	456	
		125	8.6	2080	55.7	8250	221	16,000	429	26,600	713	
		150	10.3	2550	68.3	10,200	273	20,300	544			
		200	13.8	3370	90.3	13,500	362	29,400	788			
		250	17.2	4170	112	16,900	453	36,200	970			

— Maximum operating inlet pressure is exceeded.

- continued -

Table 6. Flow Capacities in SCFH / Nm³/h of 0.6 Specific Gravity Natural Gas at 1% Droop in Absolute Outlet Pressure for 3/4 NPT (Downstream Control Line in Body Size Piping) (continued)

PILOT SPRING RANGE, PART NUMBER, AND COLOR CODE	OUTLET PRESSURE SETTING		INLET PRESSURE		3/4 NPT BODY SIZE							
					Orifice Diameter, Inches / mm							
	psig	bar	psig	bar	3/8 x 1/8 / 9.5 x 3.2	3/8 x 1/4 / 9.5 x 6.4	3/8 / 9.5		1/2 / 13			
35 to 100 psig / 2.4 to 6.9 bar 1K748527202 Red	100	6.9	125	8.6	1660	44.5	6680	179	12,500	335	18,000	482
			150	10.3	2360	63.3	9320	250	17,900	480		
			200	13.8	3330	89.2	13,400	359	26,600	713		
			250	17.2	4170	112	16,900	453	36,200	970		

Maximum operating inlet pressure is exceeded.

Table 7. Flow Capacities in SCFH / Nm³/h of 0.6 Specific Gravity Natural Gas at 1% Droop in Absolute Outlet Pressure for NPS 1 / DN 25 (Downstream Control Line in Body Size Piping)

PILOT SPRING RANGE, PART NUMBER, AND COLOR CODE	OUTLET PRESSURE SETTING		INLET PRESSURE		NPS 1 / DN 25 BODY SIZE							
					Orifice Diameter, Inches / mm							
	psig	bar	psig	bar	3/8 x 1/8 / 9.5 x 3.2	3/8 x 1/4 / 9.5 x 6.4	3/8 / 9.5		1/2 / 13			
5 to 35 psig / 0.34 to 2.4 bar 1B788327022 Silver	5	0.34	30	2.1	700	18.8	2840	76.1	6040	162	10,100	271
			40	2.8	860	23.1	3500	93.8	7480	200	13,100	351
			50	3.5	1020	27.3	4140	111	8850	237	15,400	413
			60	4.1	1170	31.4	4780	128	10,200	273	17,800	477
			80	5.5	1490	39.9	6060	162	12,900	346	18,500	496
			100	6.9	1800	48.2	7340	197	15,700	421	18,500	496
			125	8.6	2200	59.0	8940	240	18,500	496	18,500	496
			150	10.3	2580	69.1	10,500	281	18,500	496		
	200	13.8	3370	90.3	13,700	367	18,500	496				
	250	17.2	4170	112	16,900	453	18,500	496				
	10	6.9	30	2.1	690	18.5	2760	74.0	5840	157	8930	239
			40	2.8	860	23.1	3500	93.8	7480	200	13,100	351
			50	3.5	1020	27.3	4140	111	8850	237	15,400	413
			60	4.1	1170	31.4	4780	128	10,200	273	17,800	477
			80	5.5	1490	39.9	6060	162	12,900	346	22,600	606
			100	6.9	1800	48.2	7340	197	15,700	421	22,600	606
			125	8.6	2200	59.0	8940	240	19,100	512	22,600	606
			150	10.3	2580	69.1	10,500	281	22,500	603		
	200	13.8	3370	90.3	13,700	367	22,600	606				
	250	17.2	4170	112	16,900	453	22,600	606				
20	1.4	30	2.1	590	15.8	2310	61.9	4820	129	6400	172	
		40	2.8	820	22.0	3250	87.1	6830	183	10,500	281	
		50	3.5	1000	26.8	4030	108	8500	228	13,400	359	
		60	4.1	1170	31.4	4780	128	10,200	273	17,800	477	
		80	5.5	1490	39.9	6060	162	12,900	346	22,600	606	
		100	6.9	1800	48.2	7340	197	15,700	421	27,400	734	
		125	8.6	2200	59.0	8940	240	19,100	512	33,300	892	
		150	10.3	2580	69.1	10,500	281	22,500	603			
200	13.8	3370	90.3	13,700	367	29,400	788					
250	17.2	4170	112	16,900	453	33,300	892					
30	2.1	50	3.5	930	24.9	3680	98.6	7720	207	11,700	314	
		60	4.1	1140	30.6	4530	121	9540	256	15,600	418	
		80	5.5	1490	39.9	6060	162	12,900	346	22,600	606	
		100	6.9	1800	48.2	7340	197	15,700	421	27,400	734	
		125	8.6	2200	59.0	8940	240	19,100	512	33,300	892	
		150	10.3	2580	69.1	10,500	281	22,500	603			
		200	13.8	3370	90.3	13,700	367	29,400	788			
		250	17.2	4170	112	16,900	453	36,200	970			
35 to 100 psig / 2.4 to 6.9 bar 1K748527202 Red	40	2.8	60	4.1	1030	27.6	4070	109	8530	229	11,000	300
			80	5.5	1450	38.9	5790	155	12,200	327	20,000	536
			100	6.9	1790	48.0	7340	197	15,700	421	27,400	734
			125	8.6	2200	59.0	8940	240	19,100	512	33,300	892
			150	10.3	2580	69.1	10,400	279	22,500	603		
			200	13.8	3370	90.3	13,500	362	29,400	788		
250	17.2	4170	112	16,900	453	36,200	970					

Maximum operating inlet pressure is exceeded.

- continued -

Bulletin 71.2:627F

Table 7. Flow Capacities in SCFH / Nm³/h of 0.6 Specific Gravity Natural Gas at 1% Droop in Absolute Outlet Pressure for NPS 1 / DN 25 (Downstream Control Line in Body Size Piping) (continued)

PILOT SPRING RANGE, PART NUMBER, AND COLOR CODE	OUTLET PRESSURE SETTING		INLET PRESSURE		NPS 1 / DN 25 BODY SIZE							
					Orifice Diameter, Inches / mm							
	psig	bar	psig	bar	3/8 x 1/8 / 9.5 x 3.2	3/8 x 1/4 / 9.5 x 6.4	3/8 / 9.5		1/2 / 13			
35 to 100 psig / 2.4 to 6.9 bar 1K748527202 Red	50	3.4	70	4.8	1130	30.3	4450	119	9300	249	11,200	300
			80	5.5	1370	36.7	5420	145	11,400	306	18,300	490
			100	6.9	1770	47.4	7060	189	14,900	399	24,400	654
			125	8.6	2200	59.0	8940	240	19,100	512	33,300	892
			150	10.3	2590	69.4	10,400	279	22,500	603		
			200	13.8	3370	90.3	13,500	362	29,400	788		
			250	17.2	4170	112	16,900	453	36,200	970		
			80	5.5	1220	82.7	4790	128	10,000	268	12,900	346
	100	6.9	1700	45.6	6730	180	14,200	381	22,900	614		
	125	8.6	2170	58.2	8700	233	18,400	493	30,300	812		
	150	10.3	2580	69.1	10,300	276	22,500	603				
	200	13.8	3370	90.3	13,500	362	29,400	788				
	250	17.2	4170	112	16,900	453	36,200	970				
	100	6.9	1490	39.9	5870	157	12,300	330	18,000	482		
	125	8.6	2080	55.7	8250	221	16,900	453	28,100	753		
	150	10.3	2550	68.3	10,200	273	20,300	544				
	200	13.8	3370	90.3	13,500	362	29,400	788				
	250	17.2	4170	112	16,900	453	36,200	970				
	125	8.6	1660	44.5	6680	179	13,900	373	19,400	520		
	150	10.3	2360	63.3	9320	250	20,000	536				
	200	13.8	3330	89.2	13,400	359	28,300	758				
	250	17.2	4170	112	16,900	453	36,200	970				

☐ – Maximum operating inlet pressure is exceeded.

Table 8. Flow Capacities in SCFH / Nm³/h of 0.6 Specific Gravity Natural Gas at 1% Droop in Absolute Outlet Pressure for NPS 2 / DN 50 (Downstream Control Line in Body Size Piping)

PILOT SPRING RANGE, PART NUMBER, AND COLOR CODE	OUTLET PRESSURE SETTING		INLET PRESSURE		NPS 2 / DN 50 BODY SIZE							
					Orifice Diameter, Inches / mm							
	psig	bar	psig	bar	3/8 x 1/8 / 9.5 x 3.2	3/8 x 1/4 / 9.5 x 6.4	3/8 / 9.5		1/2 / 13			
5 to 35 psig / 0.34 to 2.4 bar 1B788327022 Silver	5	0.34	30	2.1	700	18.8	2840	76.1	6150	165	10,100	271
			40	2.8	860	23.1	3500	93.8	7760	208	13,800	370
			50	3.5	1020	27.3	4140	111	9180	246	16,300	437
			60	4.1	1170	31.4	4780	128	10,600	284	18,800	504
			80	5.5	1490	39.9	6060	162	13,400	359	23,800	638
			100	6.9	1800	48.2	7340	197	16,300	437	28,900	775
			125	8.6	2200	59.0	8940	240	19,800	531	30,000	804
			150	10.3	2580	69.1	10,500	281	23,400	627		
			200	13.8	3370	90.3	13,700	367	30,000	804		
			250	17.2	4170	112	16,900	453	30,000	804		
			30	2.1	690	18.5	2760	74.0	5870	157	9500	255
			40	2.8	860	23.1	3500	93.8	7760	208	13,800	370
	50	3.5	1020	27.3	4140	111	9130	246	16,300	437		
	60	4.1	1170	31.4	4780	128	10,600	284	18,800	504		
	80	5.5	1490	39.9	6060	162	13,400	359	23,800	638		
	100	6.9	1800	48.2	7340	197	16,300	437	28,900	775		
	125	8.6	2200	59.0	8940	240	19,800	531	35,100	941		
	150	10.3	2580	69.1	10,500	281	23,400	627				
	200	13.8	3370	90.3	13,700	367	30,500	817				
	250	17.2	4170	112	16,900	453	37,600	1008				
	30	2.1	590	15.8	2310	61.9	4750	127	7000	188		
	40	2.8	820	22.0	3250	97.1	6820	183	10,900	292		
	50	3.5	1000	26.8	4030	108	8570	230	13,900	373		
	60	4.1	1170	31.4	4780	128	10,600	284	18,800	410		
	80	5.5	1490	39.9	6060	162	13,400	359	23,800	638		
	100	6.9	1800	48.2	7340	197	16,300	437	28,900	775		
	125	8.6	2200	59.0	8940	240	19,800	531	35,100	941		
	150	10.3	2580	69.1	10,500	281	23,400	627				
	200	13.8	3370	90.3	13,700	367	30,500	817				
	250	17.2	4170	112	16,900	453	37,600	1008				

☐ – Maximum operating inlet pressure is exceeded.

- continued -

Table 8. Flow Capacities in SCFH / Nm³/h of 0.6 Specific Gravity Natural Gas at 1% Droop in Absolute Outlet Pressure for NPS 2 / DN 50 (Downstream Control Line in Body Size Piping) (continued)

PILOT SPRING RANGE, PART NUMBER, AND COLOR CODE	OUTLET PRESSURE SETTING		INLET PRESSURE		NPS 2 / DN 50 BODY SIZE							
					Orifice Diameter, Inches / mm							
	psig	bar	psig	bar	3/8 x 1/8 / 9.5 x 3.2	3/8 x 1/4 / 9.5 x 6.4	3/8 / 9.5	1/2 / 13				
5 to 35 psig / 0.34 to 2.4 bar 1B788327022 Silver	30	2.1	50	3.5	930	24.9	3680	98.6	7670	206	12,100	324
			60	4.1	1140	30.6	4530	121	9540	256	15,300	410
			80	5.5	1490	39.9	6060	162	13,500	362	23,800	638
			100	6.9	1800	48.2	7340	197	16,300	437	28,900	775
			125	8.6	2200	59.0	8940	240	19,800	531	35,100	941
			150	10.3	2580	69.1	10,500	281	23,400	627		
			200	13.8	3370	90.3	13,700	367	30,500	817		
250	17.2	4170	112	16,900	453	37,600	1008					
35 to 100 psig / 2.4 to 6.9 bar 1K748527202 Red	40	2.8	60	4.1	1030	27.6	4070	109	8440	226	12,000	322
			80	5.5	1450	38.9	5790	155	12,300	330	19,700	528
			100	6.9	1790	48.0	7340	197	16,300	437	28,900	775
			125	8.6	2200	59.0	8940	240	19,800	531	35,100	941
			150	10.3	2580	69.1	10,400	279	23,400	627		
			200	13.8	3370	90.3	13,500	362	30,500	817		
	250	17.2	4170	112	16,900	453	37,600	1008				
	50	3.4	70	4.8	1130	30.3	4450	119	8460	227	14,000	375
			80	5.5	1370	36.7	5420	145	11,300	303	17,900	480
			100	6.9	1770	47.4	7060	189	15,000	402	24,200	649
			125	8.6	2200	59.0	8940	240	19,800	531	35,100	941
			150	10.3	2590	69.4	10,400	279	23,400	627		
			200	13.8	3370	90.3	13,500	362	30,500	817		
	250	17.2	4170	112	16,900	453	37,600	1008				
	60	4.1	80	5.5	1220	32.7	4790	128	9860	264	14,000	375
			100	6.9	1700	45.6	6730	180	14,100	378	22,400	600
			125	8.6	2170	58.2	8700	233	18,500	496	30,000	804
			150	10.3	2580	69.1	10,300	276	23,400	627		
			200	13.8	3370	90.3	13,500	362	30,500	817		
			250	17.2	4170	112	16,900	453	37,600	1008		
	75	5.2	100	6.9	1490	39.9	5870	157	12,100	324	18,800	504
			125	8.6	2080	55.7	8250	221	17,300	464	27,600	740
			150	10.3	2550	68.3	10,200	273	21,700	582		
			200	13.8	3370	90.3	13,500	362	30,500	817		
250			17.2	4170	112	16,900	453	37,600	1008			
100			6.9	1660	44.5	6680	179	13,700	367	21,200	568	
150	10.3	2360	63.3	9320	250	19,400	520					
200	13.8	3330	89.2	13,400	359	28,500	764					
250	17.2	4170	112	16,900	453	37,600	1008					

— Maximum operating inlet pressure is exceeded.

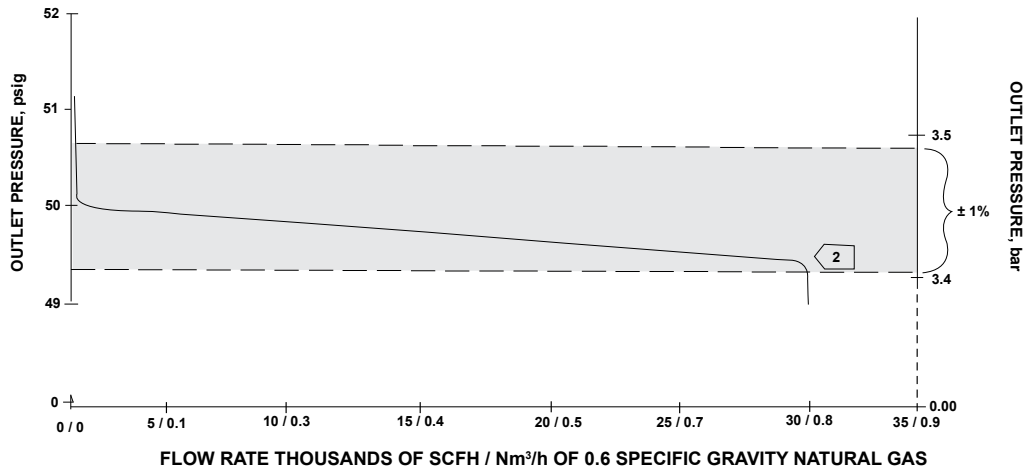

2 3/8-INCH / 9.5 mm ORIFICE. ACTUATOR SPRING 35 to 100 psig / 2.4 to 6.9 bar RANGE (RED COLOR CODE) PILOT SPRING 200 psig / 13.8 bar INLET PRESSURE

Figure 3. Typical Performance Curve for 3/4 NPT Type 627F Regulator

Bulletin 71.2:627F

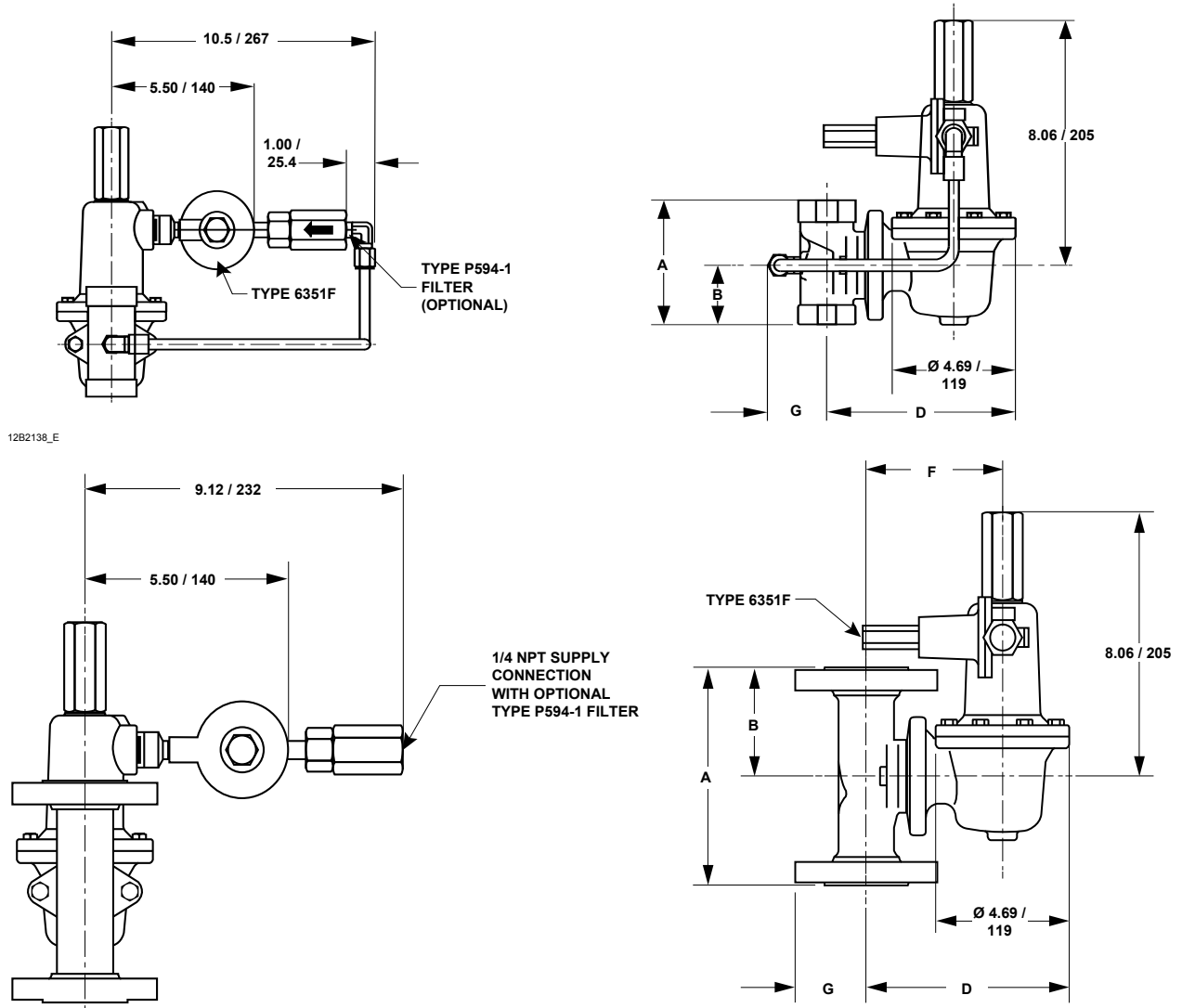

12B2138_E

12B7144_C

INCHES / mm

Figure 4. Dimensions

Table 9. Dimensions

BODY SIZE		END CONNECTION STYLE	DIMENSIONS, Inches / mm									
Inches	DN		A		B		D		F		G	
3/4	----	NPT	4.06	103	1.94	49	6.75	171	----	----	2.00	51
1	----	NPT	4.06	103	1.94	49	6.75	171	----	----	2.00	51
1	25	CL150 RF	7.25	184	3.62	92	6.75	171	4.38	111	2.12	54
		CL300 RF	7.75	197	3.88	99					2.44	62
		CL600 RF	8.25	210	4.12	105					2.44	62
		PN 16/25/40	7.80	198	3.90	99					2.31	59
2	50	NPT	5.00	127	2.50	64	7.12	181	----	----	2.62	67
		CL150 RF	10.00	254	5.00	127	7.12	181	4.75	121	3.00	76
		CL300 RF	10.50	267	5.25	133					3.25	83
		CL600 RF	11.25	286	5.62	143					3.25	83
		PN 16/25/40	10.31	262	5.16	131					3.25	83

Ordering Information

Application

When ordering, specify:

1. Type of regulator
2. Body size
3. Body material and trim material
4. Orifice size in inches / mm
5. Control spring range in psig / bar

Construction

Refer to the specifications and to each referenced table; specify the desired selection whenever there is a choice to be made. The standard assembly position is shown in Figure 1, but an alternate assembly position may be factory-ordered or can be accomplished in the field by unbolting the body or spring case using the instructions in the appropriate section of the instruction manual. For installation dimensions, refer to Figure 4.

Ordering Guide

Body Material, Body Size, and End Connection Style (Select One)

Ductile Iron

- 3/4 NPT***
- 1 NPT***
- 2 NPT***

WCC Steel

- 3/4 NPT***
- 1 NPT***
- NPS 1 / DN 25, CL150 RF**
- NPS 1 / DN 25, CL300 RF**
- NPS 1 / DN 25, CL600 RF**
- NPS 1 / DN 25, PN 16/25/40**
- 2 NPT***
- NPS 2 / DN 50, CL150 RF**
- NPS 2 / DN 50, CL300 RF**
- NPS 2 / DN 50, CL600 RF**
- NPS 2 / DN 50, PN 16/25/40**

Spring Case and Diaphragm Casing Material (Select One)

- Aluminum***
- Ductile iron***
- WCC steel***

Trim Material (Select One)

- Aluminum***
- Stainless steel***

Orifice Size (Select One)

- 3/8 x 1/8-inch / 9.5 x 3.2 mm**
- 3/8 x 1/4-inch / 9.5 x 6.4 mm**
- 3/8-inch / 9.5 mm***
- 1/2-inch / 13 mm***

Outlet Pressure Range (Select One)

- 5 to 35 psig / 0.34 to 2.4 bar, Unpainted***
- 35 to 100 psig / 2.4 to 6.9 bar, Red***

Pilot Supply Filter (Optional)

- Type P594-1

Pilot Supply Steel Tubing (Optional)

- With Type P594-1 Filter
- Without Filter

Replacement Parts Kit (Optional)

- Yes, send one replacement parts kit to match this order.

Regulators Quick Order Guide	
***	Readily Available for Shipment
**	Allow Additional Time for Shipment
*	Special Order, Constructed from Non-Stocked Parts. Consult Your local Sales Office for Availability.
Availability of the product being ordered is determined by the component with the longest shipping time for the requested construction.	

Specification Worksheet

Application:
 Specific Use _____
 Line Size _____
 Gas Type and Specific Gravity _____
 Gas Temperature _____
 Does the Application Require Overpressure Protection?
 Yes No If yes, which is preferred:
 Relief Valve Monitor Regulator Shutoff Device
 Is overpressure protection equipment selection assistance desired? _____

Pressure:
 Maximum Inlet Pressure (P_{1max}) _____
 Minimum Inlet Pressure (P_{1min}) _____
 Downstream Pressure Setting(s) (P_2) _____
 Maximum Flow (Q_{max}) _____

Performance Required:
 Accuracy Requirements? _____
 Need for Extremely Fast Response? _____

Other Requirements: _____

Industrial Regulators

Emerson Process Management Regulator Technologies, Inc.

USA - Headquarters
 McKinney, Texas 75069-1872, USA
 Tel: +1 800 558 5853
 Outside U.S. +1 972 548 3574

Asia-Pacific
 Shanghai 201206, China
 Tel: +86 21 2892 9000

Europe
 Bologna 40013, Italy
 Tel: +39 051 419 0611

Middle East and Africa
 Dubai, United Arab Emirates
 Tel: +971 4811 8100

Natural Gas Technologies

Emerson Process Management Regulator Technologies, Inc.

USA - Headquarters
 McKinney, Texas 75069-1872, USA
 Tel: +1 800 558 5853
 Outside U.S. +1 972 548 3574

Asia-Pacific
 Singapore 128461, Singapore
 Tel: +65 6770 8337

Europe
 Bologna 40013, Italy
 Tel: +39 051 419 0611
 Chartres 28008, France
 Tel: +33 2 37 33 47 00

TESCOM

Emerson Process Management Tescom Corporation

USA - Headquarters
 Elk River, Minnesota 55330-2445, USA
 Tels: +1 763 241 3238
 +1 800 447 1250

Europe
 Selmsdorf 23923, Germany
 Tel: +49 38823 31 287

Asia-Pacific
 Shanghai 201206, China
 Tel: +86 21 2892 9499

For further information visit www.fisherregulators.com

The Emerson logo is a trademark and service mark of Emerson Electric Co. All other marks are the property of their prospective owners. Fisher is a mark owned by Fisher Controls International LLC, a business of Emerson Process Management.

The contents of this publication are presented for informational purposes only, and while every effort has been made to ensure their accuracy, they are not to be construed as warranties or guarantees, express or implied, regarding the products or services described herein or their use or applicability. We reserve the right to modify or improve the designs or specifications of such products at any time without notice.

Emerson Process Management Regulator Technologies Inc. does not assume responsibility for the selection, use or maintenance of any product. Responsibility for proper selection, use and maintenance of any Emerson Process Management Regulator Technologies Inc. product remains solely with the purchaser.