

October 2014

Type MR108 Direct-Operated Backpressure Regulator

Contents

| | |
|------------------------------|----|
| Introduction..... | 3 |
| Specifications | 2 |
| Principle of Operation | 3 |
| Installation | 6 |
| Overpressure Protection..... | 8 |
| Startup..... | 8 |
| Adjustment | 8 |
| Shutdown..... | 9 |
| Maintenance..... | 10 |
| Parts List..... | 16 |

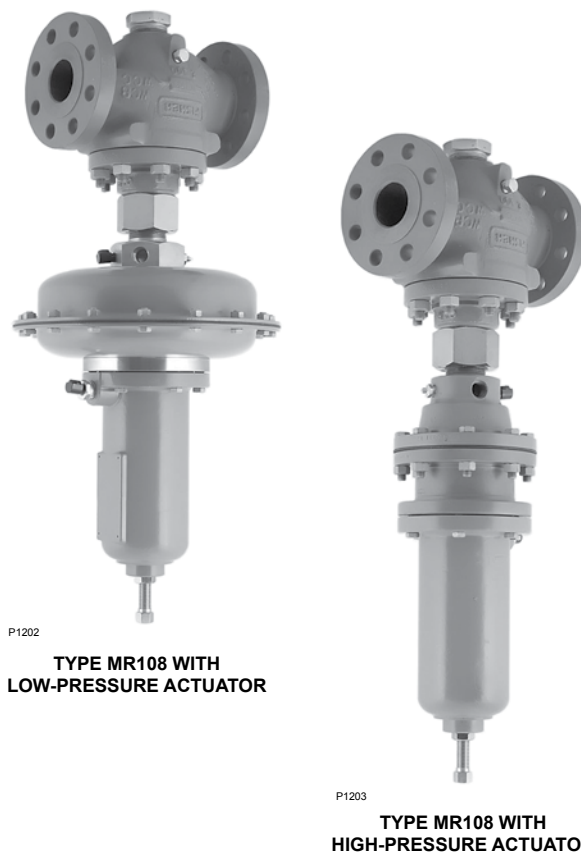

P1202
TYPE MR108 WITH
LOW-PRESSURE ACTUATOR

P1203
TYPE MR108 WITH
HIGH-PRESSURE ACTUATOR

Figure 1. Type MR108 Direct-Operated Backpressure Regulators

WARNING

Failure to follow these instructions or to properly install and maintain this equipment could result in an explosion, fire and/or chemical contamination causing property damage and personal injury or death.

Fisher® backpressure regulators must be installed, operated and maintained in accordance with federal, state and local codes, rules and regulations and Emerson Process Management Regulator Technologies, Inc. (Emerson™) instructions.

If a leak develops or if the outlet continually vents gas, service to the unit may be required. Failure to correct trouble could result in a hazardous condition. Only a qualified person must install or service the unit.

Installation, operation and maintenance procedures performed by unqualified personnel may result in improper adjustment and unsafe operation. Either condition may result in equipment damage or personal injury. Use qualified personnel when installing, operating and maintaining the Type MR108 backpressure regulator.

Note

To avoid cavitation, it is recommended that the customer follow the bulletin capacity sizing guidelines found in Bulletin 71.4:MR108.



Type MR108

Specifications

The Specifications section on this page provides the ratings and other specifications for the Type MR108. The following information is stamped on the nameplate fastened on the regulator at the factory: type; body size; maximum inlet, outlet and differential pressure; maximum pressure above setpoint; maximum casing pressure; maximum temperature; spring range; cage type; and trim and diaphragm material.

Body Sizes and End Connection Styles

See Table 1

Shutoff Classification Per ANSI/FCI 70-3-2004

Class VI (Soft Seat)

Maximum Inlet, Outlet and Emergency

Casing Pressure⁽¹⁾

See Table 4

Backpressure Control Range⁽¹⁾

5 to 300 psig / 0.34 to 20.7 bar; See Table 2

Maximum Setpoint

Low-Pressure Actuator: 35 psig / 2.4 bar

High-Pressure Actuator:

Nitrile (NBR) and Ethylene Propylene (EPDM)

Diaphragm: 300 psig / 20.7 bar

Fluorocarbon (FKM) Diaphragm: 150 psig / 10.3 bar

Maximum Pressure Over Setpoint to Avoid Internal Parts Damage⁽¹⁾

Low-Pressure Actuator: 20 psig / 1.4 bar

High-Pressure Actuator: 120 psig / 8.3 bar

Maximum Differential Pressures

Low-Pressure Actuator: 70 psig / 4.8 bar

High-Pressure Actuator: 400 psig / 27.6 bar or maximum inlet pressure, whichever is lower

Material Temperature Capabilities⁽¹⁾

Nitrile (NBR): -20 to 180°F / -29 to 82°C

Fluorocarbon (FKM): 20 to 250°F / -7 to 121°C⁽²⁾

Ethylene Propylene (EPDM): -20 to 225°F / -29 to 107°C⁽³⁾

Flow and Sizing Coefficients

See Table 3

Pressure Registration

External

Upstream Control Line Connection Size

1/2 NPT

Spring Case Vent

Type Y602-12

Pressure-Loaded Spring Case Vent Connection

1/2 NPT

Approximate Weights

For Type MR108 with Low-Pressure Actuator

NPS 1 / DN 25: 88 lbs / 40 kg

NPS 2 / DN 50: 118 lbs / 54 kg

NPS 3 / DN 80: 167 lbs / 76 kg

NPS 4 / DN 100: 176 lbs / 80 kg

For Type MR108 with High-Pressure Actuator

NPS 1 / DN 25: 78 lbs / 35 kg

NPS 2 / DN 50: 107 lbs / 49 kg

NPS 3 / DN 80: 156 lbs / 71 kg

NPS 4 / DN 100: 166 lbs / 75 kg

Options

- Inlet Pressure Gauge Tap on Body
- Pressure-Loaded Actuator
- Drain Valve
- NACE Construction
- Bleed Valve (for High-Pressure Actuator Only)
- Ethylene Propylene (EPDM) Elastomer Trim Parts

1. The pressure/temperature limits in this Instruction Manual or any applicable standard limitation should not be exceeded.

2. Fluorocarbon (FKM) is limited to 200°F / 93°C in hot water.

3. Ethylene Propylene (EPDM) is limited to 20 to 225°F / -7 to 107°C when used with Low Pressure Actuator.

Table 1. Body Sizes and End Connection Styles

| BODY MATERIAL | END CONNECTION STYLES | |
|--|--|---|
| | NPS 1 and 2 / DN 25 and 50 Body Sizes | NPS 3 and 4 / DN 80 and 100 Body Sizes |
| Cast Iron | NPT, CL125 FF or CL250 RF | CL125 FF or CL250 RF |
| WCC Steel ⁽¹⁾⁽²⁾ | NPT, CL150 RF, CL300 RF, CL600 RF or PN 16/25/40 RF | CL150 RF, CL300 RF, CL600 RF or PN 16 RF |
| CF8M Stainless steel ⁽¹⁾⁽²⁾ | NPT, CL150 RF, CL300 RF, CL600 RF or PN 16/25/40 RF | CL150 RF, CL300 RF, CL600 RF or PN 16 RF |
| CF3M Stainless steel ⁽¹⁾⁽²⁾ | NPT, CL150 RF, CL300 RF, CL600 RF or PN 16/25/40 RF | CL150 RF, CL300 RF, CL600 RF or PN 16 RF |

1. Optional NACE construction available.

2. Constructions meet API 614 requirements.

Table 2. Backpressure Control Ranges

| ACTUATOR TYPE | SPRING RANGE | | SPRING PART NUMBER | SPRING COLOR CODE | SPRING WIRE DIAMETER | | SPRING FREE LENGTH | | MAXIMUM PRESSURE OVER SETPOINT TO AVOID INTERNAL PARTS DAMAGE | |
|---------------|---------------------------|-----------------------------|--------------------|-------------------|----------------------|------|--------------------|-----|---|-----|
| | psig | bar | | | in. | mm | in. | mm | psig | bar |
| Low Pressure | 5 to 14 | 0.34 to 0.97 | GE42909X012 | White | 0.44 | 11.2 | 9.70 | 246 | 20 | 1.4 |
| | 8 to 24 | 0.55 to 1.7 | GE42910X012 | Silver | 0.50 | 12.7 | | | | |
| | 12 to 30 | 0.83 to 2.1 | GE42911X012 | Orange | 0.56 | 14.2 | | | | |
| | 15 to 35 | 1.0 to 2.4 | GE43002X012 | Red | 0.63 | 16.0 | | | | |
| High Pressure | 25 to 40 | 1.7 to 2.8 | GE42906X012 | Blue | 0.33 | 8.38 | | | 120 | 8.3 |
| | 35 to 70 | 2.4 to 4.8 | GE42907X012 | Green | 0.38 | 9.65 | | | | |
| | 55 to 120 | 3.8 to 8.3 | GE42909X012 | White | 0.44 | 11.2 | | | | |
| | 90 to 200 ⁽¹⁾ | 6.2 to 13.8 ⁽¹⁾ | GE42910X012 | Silver | 0.50 | 12.7 | | | | |
| | 175 to 300 ⁽²⁾ | 12.1 to 20.7 ⁽²⁾ | GE43002X012 | Red | 0.63 | 16.0 | | | | |

1. Maximum setpoint is limited to 150 psig / 10.3 bar for constructions with Fluorocarbon (FKM) diaphragm.
2. Not applicable for constructions with Fluorocarbon (FKM) diaphragm.

Table 3. Wide-Open Flow and IEC Sizing Coefficients

| BODY SIZE | | WIDE-OPEN COEFFICIENTS | | IEC SIZING COEFFICIENTS | | | | |
|--|-----|----------------------------|----------------|-------------------------|----------------|----------------|----------------|----------------|
| NPS | DN | Line Size Equals Body Size | | C ₁ | K _m | F _L | X _T | F _d |
| | | C _g | C _v | | | | | |
| Quick Opening Cage | | | | | | | | |
| 1 | 25 | 597 | 17.5 | 34.1 | 0.81 | 0.90 | 0.73 | 0.43 |
| 2 | 50 | 1740 | 48.2 | 36.1 | 0.81 | 0.90 | 0.82 | 0.34 |
| 3 | 80 | 3540 | 103.1 | 34.4 | 0.76 | 0.87 | 0.75 | 0.32 |
| 4 | 100 | 4300 | 135.9 | 31.6 | 0.72 | 0.85 | 0.65 | 0.3 |
| Reduced Port Quick Opening Cage | | | | | | | | |
| 2 | 50 | 1570 | 43.8 | 35.9 | 0.81 | 0.90 | 0.72 | 0.36 |

Introduction

Scope of the Manual

This instruction manual provides installation, adjustment, maintenance and parts ordering information for Type MR108 backpressure regulators.

Description

The Type MR108 regulators are direct-operated, backpressure, high-capacity, multi-purpose regulators. They are designed to handle pressures of up to 400 psig / 27.6 bar and temperatures of up to 250°F / 121°C. Large multi-purpose regulators provide fast, simple, reliable and economical pressure control for a number of applications and are suitable for different flow media such as liquid, air and gas. In addition, the drain valve option allows you to drain the system without expensive spool pieces saving you time and space. Also, the bleed valve option allows you to purge the air trapped underneath the diaphragm when the high-pressure regulator is installed in the upright position. Typical applications include lube oil, cooling water and natural gas district stations. Type MR108 backpressure regulators are typically used in lube

oil installations or any application where speed of response is critical, minimum differential pressure is a concern or fluid is not free of impurities.

Principle of Operation

Refer to Figure 2. The Type MR108 is a multi-purpose backpressure regulator. Inlet pressure is registered externally through a 1/2 NPT control line connection located at the low-pressure actuator bonnet or high-pressure actuator lower casing. When inlet pressure rises above the set pressure, the pressure under the actuator diaphragm increases and opens the regulator. This pressure overcomes the regulator setting (which is set by the regulator control spring). Through the action of the actuator stem, the valve plug is pulled upward moving away from the seat ring and allowing fluid to escape through the cage into the downstream system. When inlet pressure drops back to set pressure, pressure under the actuator diaphragm decreases. The control spring and valve spring forces push the actuator stem downward, the valve plug moves closer to the seat ring and the flow decreases downstream as the regulator closes in response to the decreased pressure underneath the diaphragm.

Type MR108

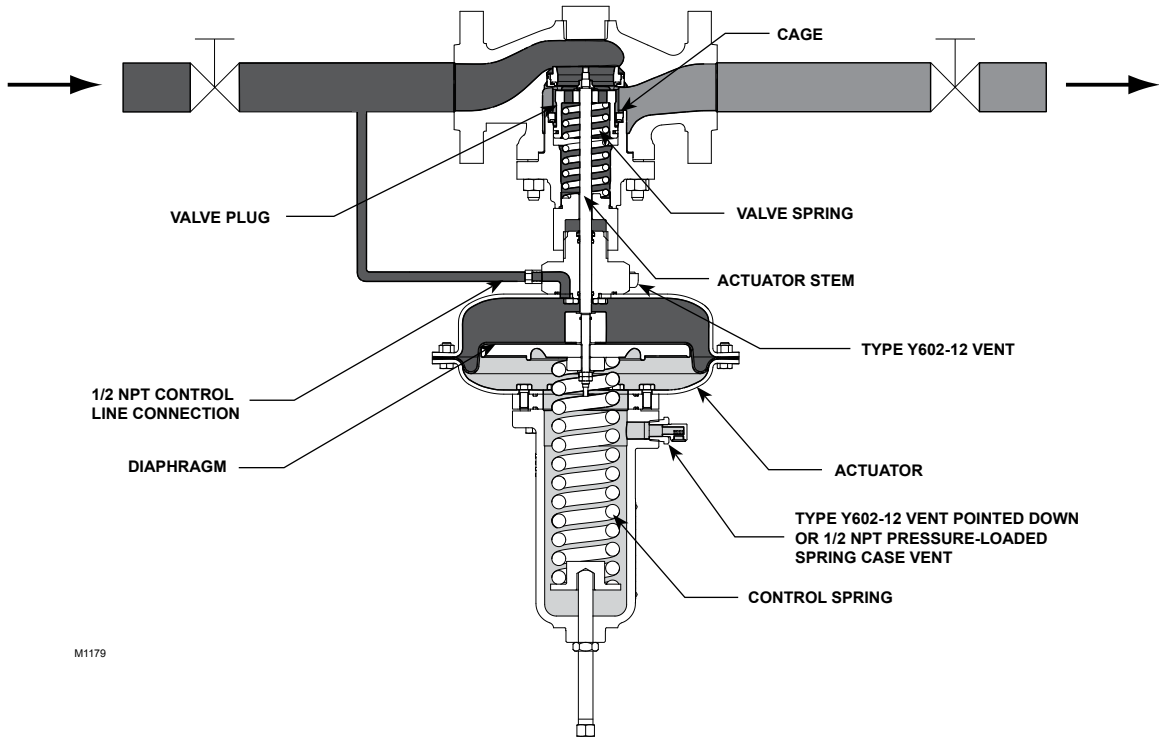

TYPE MR108 WITH LOW-PRESSURE ACTUATOR

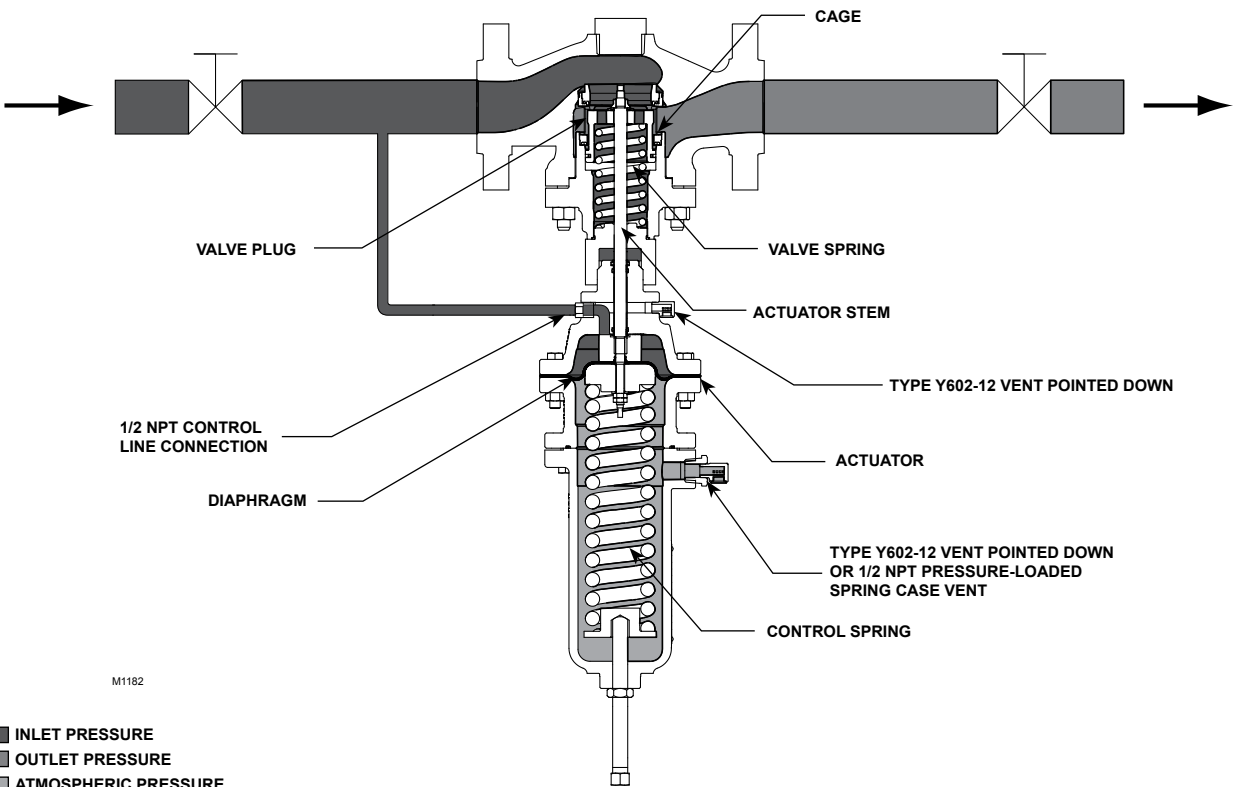

TYPE MR108 WITH HIGH-PRESSURE ACTUATOR

- INLET PRESSURE
- OUTLET PRESSURE
- ATMOSPHERIC PRESSURE

Figure 2. Type MR108 Direct-Operated Backpressure Regulator Operational Schematic

Table 4. Maximum Inlet, Outlet and Emergency Casing Pressures⁽¹⁾

| BODY MATERIAL | END CONNECTION | MAXIMUM INLET PRESSURE | | | | MAXIMUM OUTLET PRESSURE | | | | MAXIMUM EMERGENCY CASING PRESSURE | | | |
|----------------------|----------------|------------------------|-----|---------------------------------------|------|-------------------------|-----|---------------------------------------|------|-----------------------------------|-----|---------------------------------------|------|
| | | Low-Pressure Actuator | | High-Pressure Actuator ⁽²⁾ | | Low-Pressure Actuator | | High-Pressure Actuator ⁽²⁾ | | Low-Pressure Actuator | | High-Pressure Actuator ⁽²⁾ | |
| | | psig | bar | psig | bar | psig | bar | psig | bar | psig | bar | psig | bar |
| Cast Iron | NPT | 70 | 4.8 | 340 | 23.4 | 70 | 4.8 | 340 | 23.4 | 70 | 4.8 | 340 | 23.4 |
| | CL125 FF | | | 175 | 12.1 | | | 175 | 12.1 | | | 175 | 12.1 |
| | CL250 RF | | | 400 | 27.6 | | | 400 | 27.6 | | | 400 | 27.6 |
| WCC Steel | NPT | 70 | 4.8 | 400 | 27.6 | 70 | 4.8 | 400 | 27.6 | 70 | 4.8 | 400 | 27.6 |
| | CL150 RF | | | 245 | 16.9 | | | 245 | 16.9 | | | 245 | 16.9 |
| | CL300 RF | | | 400 | 27.6 | | | 400 | 27.6 | | | 400 | 27.6 |
| | CL600 RF | | | 245 | 16.9 | | | 245 | 16.9 | | | 245 | 16.9 |
| | PN 16 RF | | | 400 | 27.6 | | | 400 | 27.6 | | | 400 | 27.6 |
| | PN 16/25/40 RF | | | 245 | 16.9 | | | 245 | 16.9 | | | 245 | 16.9 |
| CF8M Stainless steel | NPT | 70 | 4.8 | 400 | 27.6 | 70 | 4.8 | 400 | 27.6 | 70 | 4.8 | 400 | 27.6 |
| | CL150 RF | | | 225 | 15.5 | | | 225 | 15.5 | | | 225 | 15.5 |
| | CL300 RF | | | 400 | 27.6 | | | 400 | 27.6 | | | 400 | 27.6 |
| | CL600 RF | | | 225 | 15.5 | | | 225 | 15.5 | | | 225 | 15.5 |
| | PN 16 RF | | | 400 | 27.6 | | | 400 | 27.6 | | | 400 | 27.6 |
| | PN 16/25/40 RF | | | 225 | 15.5 | | | 225 | 15.5 | | | 225 | 15.5 |
| CF3M Stainless steel | NPT | 70 | 4.8 | 400 | 27.6 | 70 | 4.8 | 400 | 27.6 | 70 | 4.8 | 400 | 27.6 |
| | CL150 RF | | | 185 | 12.7 | | | 185 | 12.7 | | | 185 | 12.7 |
| | CL300 RF | | | 400 | 27.6 | | | 400 | 27.6 | | | 400 | 27.6 |
| | CL600 RF | | | 185 | 12.7 | | | 185 | 12.7 | | | 185 | 12.7 |
| | PN 16 RF | | | 400 | 27.6 | | | 400 | 27.6 | | | 400 | 27.6 |
| | PN 16/25/40 RF | | | 225 | 15.5 | | | 225 | 15.5 | | | 225 | 15.5 |

1. Pressure ratings are based on a maximum operating temperature of 250°F / 121°C.
2. Maximum inlet, outlet and emergency pressures for constructions with Fluorocarbon (FKM) diaphragm are limited to 230 psig / 15.8 bar or the body rating limit, whichever is lower.

Table 5. Type MR108 Product Assembly Torques

| PART NAME AND KEY NUMBER | TORQUE | | | | | | | |
|---|-------------------------|------------|-------------------------|------------|-------------------------|------------|--------------------------|------------|
| | NPS 1 / DN 25 Body Size | | NPS 2 / DN 50 Body Size | | NPS 3 / DN 80 Body Size | | NPS 4 / DN 100 Body Size | |
| | Ft-Lbs | N•m | Ft-Lbs | N•m | Ft-Lbs | N•m | Ft-Lbs | N•m |
| Body Flange Studs and Nuts (keys 3 and 29) | 75 to 95 | 102 to 129 | 50 to 65 | 68 to 88 | 100 to 130 | 136 to 176 | 160 to 210 | 217 to 285 |
| Adaptor (key 74) | 90 to 130 | 122 to 176 | 90 to 130 | 122 to 176 | 90 to 130 | 122 to 176 | 90 to 130 | 122 to 176 |
| Actuator Stem Flanged Hex Nut (key 41) | 16 to 18 | 22 to 24 | 16 to 18 | 22 to 24 | 16 to 18 | 22 to 24 | 16 to 18 | 22 to 24 |
| Actuator Stem Jam Nuts (key 48) | 12 to 14 | 16 to 19 | 12 to 14 | 16 to 19 | 12 to 14 | 16 to 19 | 12 to 14 | 16 to 19 |
| Low Pressure: Actuator Flange Cap Screws and Nuts (keys 57 and 58) | 27 to 29 | 37 to 39 | 27 to 29 | 37 to 39 | 27 to 29 | 37 to 39 | 27 to 29 | 37 to 39 |
| High Pressure: Actuator Flange Studs and Nuts (keys 57 and 58) | 45 to 55 | 61 to 75 | 45 to 55 | 61 to 75 | 45 to 55 | 61 to 75 | 45 to 55 | 61 to 75 |
| Bonnet and Spring Case Spacer Cap Screws (key 65) | 10 to 12 | 14 to 16 | 10 to 12 | 14 to 16 | 10 to 12 | 14 to 16 | 10 to 12 | 14 to 16 |
| Spring Case Cap Screws (key 67) | 25 to 28 | 34 to 38 | 25 to 28 | 34 to 38 | 25 to 28 | 34 to 38 | 25 to 28 | 34 to 38 |

Note: All studs, screws and nuts should be lubricated. All final torque values should be verified with a calibrated torque wrench.

Installation

WARNING

Personal injury or system damage may result if this regulator is installed, without appropriate overpressure protection, where service conditions could exceed the limits given in the Specifications section and/or regulator nameplate. Refer to Overpressure Protection section for recommendations on how to prevent service conditions from exceeding those limits.

Additionally, physical damage to the regulator may result in personal injury or property damage due to escaping of accumulated gas. To avoid such injury and damage, install the regulator in a safe location.

All vents should be kept open to permit free flow of gas to the atmosphere. Protect openings against entrance of rain, snow, insects or any other foreign material that may plug the vent or vent line. On outdoor installations, point the spring case vent downward to allow condensate to drain.

Under enclosed conditions or indoors, escaping gas may accumulate and be an explosion hazard. In these cases, the vent should be piped away from the regulator to the outdoors.

Note

To avoid premature wear of internal parts, it is recommended that the actuator be oriented up or down in liquid service as shown in Figures 2 and 3.

General Installation Instructions

WARNING

Escaping process fluid from an open bleed valve may result in regulator damage, personal injury and property

damage. To avoid such injury and damage, make certain the bleed valve (if used) is properly closed after venting air.

Always open bleed valves slowly. These valves contain no packing, so some fluid weepage will occur when the valves are opened. Operating personnel must protect themselves from exposure to system fluids.

Note

A linear cage is recommended for applications where low flow stability is a concern but it will limit the overall capacity of the regulator.

Vertical installation with the actuator installed directly above or below the main valve is recommended but for optimal performance, the actuator should be installed below the main valve. The use of a bleed valve is recommended for liquid installations that require the high pressure actuator to be mounted above the main valve. The unit will operate in horizontal installations with the actuator on the side, however, this could result in premature wear of parts. Make sure that flow will be in the same direction as that indicated by the body arrow. Orientation of the two vents should always be down. Vents may be rotated after regulator installation so that the vent screens are down.

Before installing the regulator:

- Check for damage which might have occurred during shipment.
- Check for and remove any dirt or foreign material which may have accumulated in the regulator body.
- Blow out any debris, dirt or copper sulfate in the tubing and the pipeline.
- Apply pipe compound to the external threads of the pipe before installing the regulator.
- Make sure gas flow through the regulator is in the same direction as the arrow on the body. "Inlet" and "Outlet" connections are clearly marked.

Note

For proper regulator control and operation, make certain the flow arrow matches the flow direction.

Installation Location



This regulator can be installed in a pit, which is prone to flooding. The vents of the spring case and lower diaphragm casing (High-Pressure Actuator) or bonnet (Low-Pressure Actuator) should be above the expected flood level or vent lines should be installed to terminate above the water level so that they are exposed to atmospheric pressure.

- The installed regulator should be adequately protected from vehicular traffic and damage from other external sources.
- Install the regulator with the vent pointed vertically down, see Figures 2 and 3. If the vent cannot be installed in a vertically down position, the regulator must be installed under a separate protective cover. Installing the regulator with the vent down allows condensate to drain, minimizes the entry of water or other debris from entering the vent and minimizes vent blockage from freezing precipitation.
- Do not install the Type MR108 in a location where there can be excessive water accumulation or ice formation, such as directly beneath a downspout, gutter or roof line of building. Even a protective hood may not provide adequate protection in these instances.
- Install the regulator so that any gas discharge through the vent or vent assembly is over 3 ft. / 0.9 m away from any building opening. Periodically check all vent openings to be sure that they are not plugged.

Regulators Subjected to Heavy Snow Conditions



To protect against precipitation, make certain that the vents are oriented such that the opening does not allow precipitation to enter vents.

Some installations, such as in areas with heavy snowfall, may require a hood or enclosure to protect the regulator from snow load and vent freeze over.

Upstream Control Line Installation



Personal injury, equipment damage or leakage due to escaping fluid may result if the bonnet (key 61, Low-Pressure Actuator) or lower diaphragm casing (key 62, High-Pressure Actuator) is backed off or loosened when installing control line.

The Type MR108 backpressure regulator requires an upstream control line to allow inlet pressure to register on the actuator's diaphragm to ensure proper pressure control. A 1/2 NPT control line connection is located on the bonnet (for low-pressure actuator, see Figure 2) or on the lower diaphragm casing (for high-pressure actuator, see Figure 2). The control line should be installed four to eight pipe diameter before the backpressure regulator and in an area of pipe that is free of turbulence.

Connect the upstream control line tubing to the bonnet or lower casing and run the tubing approximately 20 in. / 0.5 m upstream. For best results, the outer diameter of the control line tubing should be 3/8 in. / 9.5 mm or larger.

Vent Line Installation

The Type MR108 backpressure regulator has a 1/2 NPT vent opening in the spring case. When installed inside a building or if it is necessary to vent escaping gas away from the regulator, install a remote vent line in the spring case tapping. Vent piping should be as short and direct as possible with a minimum number of bends and elbows. The remote vent line should be at least 1/2 in. / 13 mm outer diameter tubing or 1/2 NPT pipe.

Remove the Type Y602-12 vent and the pipe bushing (key 76, Figure 4) and attach the vent line at this location. The other end of the vent line should be located outside with a screened vent (Type Y602-12 vent connector). The Type Y602-12 vent connector should be pointed down and protected as described in the Installation Location section.

Overpressure Protection

WARNING

Personal injury, equipment damage or leakage due to escaping accumulated gas or bursting of pressure-containing parts may result if this regulator is:

- **Overpressured;**
- **Used with incompatible process fluid;**
- **Installed where service conditions could exceed the limits given in the Specifications section and on the appropriate nameplate; or**
- **Where conditions exceed any ratings of adjacent piping or piping connections.**

To avoid such injury or damage, provide pressure-relieving or pressure-limiting devices to prevent service conditions from exceeding those limits.

Overpressuring any portion of this equipment may result in equipment damage, leaks in the backpressure regulator or personal injury due to bursting of pressure-containing parts. The system should be inspected after any overpressure condition.

Backpressure control ranges are from 5 to 300 psig / 0.35 to 20.7 bar. The individual spring range of your backpressure regulator is stamped on the nameplate. Maximum inlet pressures depend upon body materials and temperatures. See the Specifications section for the maximum inlet pressure of the valve. The valve should be inspected for damage after any overpressure condition.

Startup

WARNING

To avoid possible personal injury, equipment damage or leakage due to escaping fluid, make certain the regulator is installed as instructed in the Installation section.

CAUTION

Pressure gauges must always be used to monitor downstream pressure during Startup.

1. Check that proper installation is completed and downstream equipment has been properly adjusted.
2. Make sure all block and vent valves are closed.
3. Slowly open the valves in the following order:
 - a. Loading supply and control line valve(s), if used
 - b. Inlet shut-off valve
 - c. Outlet shut-off valve
4. If the regulator has the bleed valve option, slowly open valve to allow air to escape from lower casing. Once fluid starts to bleed out, close valve.

CAUTION

The regulator is factory-set as specified on the order or at the midpoint of the spring range. The allowable spring range is stamped on the nameplate. If a pressure setting other than the one specified is desired, be sure to change the pressure setting by following the Adjustment procedure.

4. If resetting setpoint, then set the regulator to the desired set pressure according to the Adjustment procedure.

Adjustment

Key numbers are referenced in Figure 4.

WARNING

Personal injury, equipment damage or leakage due to escaping fluid may result if adjusting screw (key 73) and jam nut (key 72) are not installed properly. Also, spring (key 68) may go solid resulting in the backpressure regulator not opening if jam nut is not installed and adjusting screw is adjusted completely down.

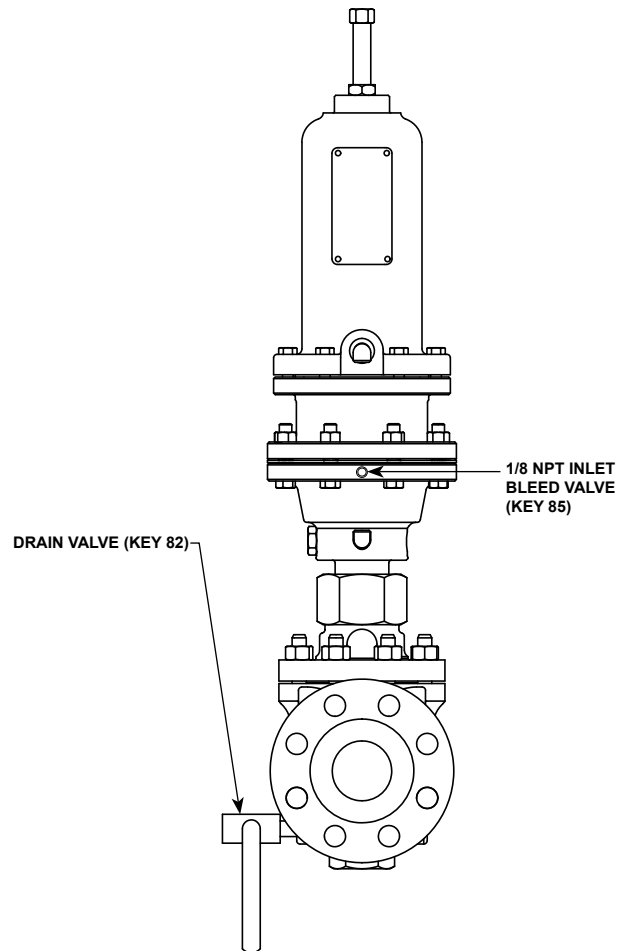

Figure 3. Type MR108 with High-Pressure Actuator, Drain Valve and Bleed Valve Option

The factory setting of the backpressure regulator is the midpoint of the spring range unless otherwise specified on order. The allowable spring range is stamped on the nameplate. If a pressure setting beyond the indicated range is required, substitute the appropriate spring. Be sure to relabel the valve to indicate the new pressure range.

Always use a pressure gauge to monitor pressure when making adjustments.

All regulator springs can be backed off to 0 psig / 0 bar. Recommended backpressure control ranges available, maximum inlet pressures and temperatures and color codes of the respective springs are shown in the Specifications section and Table 2. Loosen the jam nut (key 72). To increase the setting, turn the adjusting screw (key 73) clockwise. Turn the adjusting screw counterclockwise to decrease the setting. Tighten the jam nut to maintain the desired setting.

Shutdown



Escaping process fluid from an open drain valve may result in regulator damage, personal injury and property damage. To avoid such injury and damage, make certain the drain valve (if used) is properly closed after bleeding process fluid.

1. Isolate the regulator from the system in steps 2 and 3.
2. Close the upstream shutoff valve to the regulator inlet.
3. Close the downstream shutoff valve to the regulator outlet.

Type MR108

Table 6. Type MR108 Trim Weights

| TYPE | BODY SIZE | | TRIM WEIGHT | |
|------------------------------|-----------|-----|-------------|----|
| | NPS | DN | lbs | kg |
| MR108 Low-Pressure Actuator | 1 | 25 | 74 | 34 |
| | 2 | 50 | 79 | 36 |
| | 3 | 80 | 93 | 42 |
| | 4 | 100 | 113 | 51 |
| MR108 High-Pressure Actuator | 1 | 25 | 63 | 29 |
| | 2 | 50 | 69 | 31 |
| | 3 | 80 | 83 | 38 |
| | 4 | 100 | 102 | 46 |



WARNING

To avoid personal injury or damage of internal parts from a pressure-loaded actuator, carefully vent the regulator spring case pressure prior to inlet pressure.

- If the actuator is pressure loaded, vent the loading pressure slowly to release pressure in the spring case.

Note

To avoid internal damage due to reverse pressurization of main valve components, make certain backpressure regulator inlet pressure is bled prior to outlet pressure.

- Slowly open the downstream vent valve to vent downstream pressure.
- Leave the downstream vent valve open to vent inlet pressure and to release all remaining pressure in the regulator.
- If the regulator has the drain valve option, slowly open valve to drain fluid inside valve body. Make sure to close valve after fluid has been drained.

Maintenance



WARNING

Personal injury, equipment damage or leakage due to escaping fluid may result if seals are not properly lubricated or maintained. Due to normal part wear or damage that

may occur from external sources, this regulator should be inspected and maintained periodically. The frequency of inspection, maintenance and replacement of parts depends upon the severity of service conditions or the requirements of local, state and federal regulations.

Regulators that have been disassembled for repair must be tested for proper operation before being returned to service. Only parts manufactured by Emerson™ should be used for repairing Fisher® regulators. Restart gas utilization equipment according to normal startup procedures.

Note

To protect against reduced performance, ensure vents are not plugged when conducting routine maintenance.

Annual Maintenance

The stem O-rings on the Type MR108 actuator can be lubricated during regularly scheduled maintenance, using the grease fitting (key 44). Stem O-rings can be checked for damage during normal operation. If line pressure leakage or unexpected grease extrusion from the actuator vent (key 26) is observed during normal operation the stem O-ring needs to be replaced.

Change Nameplate

Be certain that the nameplates are updated to accurately indicate any field changes in equipment, materials, service conditions or pressure settings.

Disassembly



WARNING

To avoid personal injury resulting from sudden release of pressure, isolate the regulator from all pressure and cautiously release trapped pressure from the regulator before attempting disassembly.

Instructions are given below for disassembly of the Type MR108 backpressure regulators. Suitable lubricants are indicated on the assembly drawings. Apply the lubricants as the backpressure regulator is being reassembled.

All O-rings, gaskets and seals should be lubricated with a good grade of general-purpose lubricant and installed gently rather than forced into position. Refer to Figure 4 while servicing the backpressure regulator. For a summary of maximum torque values required for all studs, screws and nuts, refer to Table 5.



WARNING

Failure to properly follow maintenance installation procedures when replacing parts could result in regulator damage, personal injury and property damage from escaping process fluid or regulators separation during testing or after reinstallation in the pipe line.

Replacing Trim Parts

Perform this procedure when inspecting, cleaning or replacing individual trim package parts.

Note

All disassembly, trim change and reassembly steps in this section may be performed with the regulator in the main line.

The trim for the NPS 3 and NPS 4 / DN 80 and 100 body sizes (see Table 6) is heavy and may be awkward to remove or reinstall in some valve/

pipeline orientations. Follow your company policy for lifting and handling heavy parts.

1. Loosen the hex nuts (key 29) and stud bolts (key 3), remove the body flange (key 2) from the valve body (key 1) and lift out the trim package.
2. Perform any required inspection, cleaning or maintenance on the exposed surfaces of the valve body (key 1) or trim package. Replace the gasket (key 4) or cage O-ring (key 17) as necessary.
3. To gain access to the port seal (key 12), upper seal (key 15, detail Y) or valve plug parts, unscrew the flange nut (key 41, detail W) from the stem (key 40). Use the wrench flats on the stem to keep the stem from rotating. Unscrew the adaptor (key 74) from the body flange (key 2). Lift the actuator off the body flange and remove the valve spring (key 9). Unscrew the seat ring (key 13) from the cage (key 11) and the cage from the body flange (key 2). For leverage, a wrench handle or similar tool may be inserted into the seat ring slots and a strap wrench may be wrapped around the cage or a soft bar may be inserted through the windows of a standard cage. To remove the piston ring (key 14) and/or plug O-ring (key 20), remove the valve plug (key 16) from the body flange, insert a screwdriver into the pre-cut fold over area of the piston ring and unfold the piston ring.
4. Replace parts such as the gasket (key 4) and cage O-ring (key 17) if worn or damaged. Making sure that the port seal (key 12) and upper seal (key 15) were removed, install new port seal (key 12) and upper seal (key 15) in their retaining slots with the grooved sides facing out. Lightly lubricate seating surfaces and parts as necessary for ease of installation.
5. Install the plug O-ring (key 20) and piston ring (key 14) onto the valve plug (key 16). Insert the valve plug into the body flange (key 2), install the cage (key 11) plus upper seal (key 15) and cage O-ring (key 17) into the body flange and then install the seat ring (key 13) plus port seal (key 12) into the cage. Use the valve body (key 1) as a holding fixture if desired. Flip the body flange (key 2) over and anchor it on the valve body. Insert a wrench handle or similar tool into the seat ring slots for leverage when tightening the seat ring and cage.
6. Remove the upside-down body flange (key 2) if it was anchored on the body. Lightly lubricate the cage seating surfaces of the valve body web and

Type MR108

the body flange. Install the valve spring (key 9) and install the actuator on the body flange by screwing the adaptor (90 to 130 ft-lbs / 122 to 176 N•m) into the body flange. The stem will protrude through the center hole of the valve plug (key 16). Install and tighten (16 to 18 ft-lbs / 22 to 24 N•m) the flange nut (key 41) to the stem. Use the wrench flats on the stem to keep the stem from rotating.



WARNING

Personal injury, equipment damage or leakage due to escaping fluid may result if regulator bolts are not tightened to proper load. Always tighten bolts in an alternating pattern.

7. Install the body flange on the body (key 1) and secure it evenly with the stud bolts (key 3). Tighten to torque value specified in Table 5.

Actuator Maintenance



WARNING

Equipment damage, leakage and personal injury from escaping fluid may occur if external side forces are applied to the actuator. Do not stand on the actuator or apply external loads to the actuator.

Perform this procedure if it is desired to inspect or replace the diaphragm or other internal parts or if it is desired to change the set pressure range of the regulator by changing the control spring.



WARNING

To avoid possible personal injury from spring or pressure-loaded actuator, make certain the adjusting screw is completely backed off or the spring case pressure is vented prior to disassembly. Otherwise, the spring load or loading pressure could forcefully eject the spring case.

Replacing Main Spring

1. Loosen the jam nut (key 72). If a pressure-loaded actuator is used, remove the sealing washer (key 71). Using a hand wrench (not an impact gun), unscrew the adjusting screw (key 73) and remove it from the spring case(key 70).
2. Loosen and remove the cap screws (key 67) and lift off the spring case (key 70) from the spring case spacer (key 66 for Low-Pressure Actuator), upper casing welding assembly (key 87 for Low-Pressure Pressure-Loaded Actuator) or upper diaphragm casing (key 63 for High-Pressure Actuator).
3. Remove the upper spring seat (key 69) and control spring (key 68). Replace the control spring if desired.
4. For pressure-loaded spring case, replace the upper casing welding assembly top O-ring (Low-Pressure Actuator) or diaphragm casing (High-Pressure Actuator) O-ring (key 64) if necessary. Install the new O-ring in the groove on the top surface of the upper casing welding assembly (key 87) for Low-Pressure Actuator or upper diaphragm casing (key 63) for High-Pressure Actuator. If this is performed only for spring (key 68) and spring case spacer/upper diaphragm casing O-ring replacement and no further maintenance in the actuator and its internal parts is necessary, proceed to step 23 for Low-Pressure Actuator or step 20 for High-Pressure Actuator.

For Low-Pressure Actuator Diaphragm Replacement

5. Remove the cap screws (key 57) and hex nuts (key 58) connecting the casings (key 63 or 87 and 62) and diaphragm (key 56). Lift off the upper diaphragm casing (key 63) or upper casing welding assembly (key 87).
6. Unscrew the jam nuts (key 48) and remove them from the actuator stem (key 40).
7. Remove the Belleville spring washer (key 49), lower spring guide (key 52) and diaphragm plate (key 55) from the actuator stem (key 40).
8. Lift off the diaphragm (key 56) from the actuator stem (key 40) and inspect it for damage. Replace if necessary. If no further maintenance or inspection is required, proceed to step 18 to reassemble the actuator.

Note

Exercise care to ensure that the actuator stem (key 40) enters and exits the lower diaphragm head bore without pinching, cutting or damaging in any way the lower diaphragm head O-ring (key 51).

9. Carefully remove the lower diaphragm head (key 53) from the actuator stem (key 40) so that the actuator stem threads do not damage the O-ring inside the lower diaphragm head. Replace the lower diaphragm head O-ring (key 51) if necessary.
10. Remove the cap screws (key 65) connecting the lower diaphragm casing (key 62) and the internal stiffener plate (key 84) to the bonnet (key 61). Lift the lower casing off of the bonnet.
11. If it is desired to replace the bonnet and stem O-rings (keys 60 and 47) and bearings (key 46), disconnect the control line attached to bonnet (key 61). Unscrew the bonnet (key 61) from the adaptor (key 74). Remove stem (key 40) from the bonnet by pulling on the end of the stem without threads.
12. Remove the wiper (key 45, detail Z) on the threaded (orifice side) end of the bonnet (key 61) to reach the bearing (key 46) and stem O-ring (key 47). Install the new stem O-ring and bearing and put back the wiper.
13. Turn the bonnet (key 61) over and install another stem O-ring (key 47) and bearing (key 46, detail X) in the top side of the bonnet. Inspect the bonnet O-ring (key 60) installed in the groove located on the top surface of the bonnet (key 61) for any damage and replace if necessary.



WARNING

Personal injury, equipment damage or leakage due to escaping fluid may result if the bonnet (key 61) is backed off when installing control line.

14. Lubricate the bore on both ends of the bonnet (key 61). Install it over the actuator stem (key 40) and thread into the adaptor (key 74). Tighten the bonnet into the body until the connecting pipe holes in the bonnet are located 90° from the valve body ends for correct tubing alignment. Do not loosen the bonnet thread to align the pipe holes. Always tighten the bonnet to make alignment for the control line.

Note

Position the bonnet (key 61) such that the vent (key 26) is facing valve body (key 1) inlet, the lube fitting (key 44) is facing body outlet end and the 1/2 NPT control line connection (key 30) is located 90° from the valve body ends.

Note

Exercise care to ensure that the actuator stem (key 40) enters and exits the bonnet bore without pinching, cutting or damaging the actuator stem O-rings (key 47).

15. Lubricate the cap screws (key 65) and use it to position and secure the lower diaphragm casing (key 62) and internal stiffener plate (key 84) to the bonnet (key 61). Tighten the cap screws to a torque of 10 to 12 ft-lbs / 14 to 16 N•m.
16. The serrated side of the lower diaphragm head (key 53) should be facing up toward the threaded end of the actuator stem. Carefully install the lower diaphragm head (key 53) over the actuator stem (key 40).

Note

Exercise care to ensure that the actuator stem (key 40) enters and exits the lower diaphragm head bore without pinching, cutting or damaging in any way the lower diaphragm head O-ring (key 51).

17. Place the diaphragm (key 56) over the actuator stem (key 40) and on top of the lower diaphragm head (key 53). The convolutions of the diaphragm should be pointing up.
18. Place the following over the actuator stem (key 40) and on top of the diaphragm (key 56) in the following order: diaphragm plate (key 55), lower spring guide (key 52) and Belleville spring washer (key 49). The raised inner diameter of the Belleville spring washer should be pointing toward the threaded end of the actuator stem.
19. Lubricate the threads of the actuator stem (key 40) and thread the two jam nuts (key 48) onto it. Using wreckflats, hold the stem and torque the jam nuts individually. Tighten to a torque of 12 to 14 ft-lbs / 16 to 19 N•m.

Note

For pressure-loaded actuator option skip steps 20 and 21 and proceed to step 22 with upper casing welding assembly (key 87).

20. Install the upper diaphragm casing (key 63) or spring case spacer (key 66) assembly while aligning the bolt circle holes in the upper diaphragm casing, diaphragm (key 56) and lower diaphragm casing (key 62).

Note

Exercise care to ensure that the diaphragm (key 56) is not pinched, twisted or wrinkled while compressing between the upper and lower diaphragm casings (keys 62 and 63).

21. Lubricate the cap screws (key 57) and nuts (key 58) and carefully insert through holes in the outer flange of the diaphragm casings (keys 62 and 63) and diaphragm (key 56). Tighten the cap screws to the hex nuts to a final torque value of 27 to 29 ft-lbs / 37 to 39 N•m.
22. Place the control spring (key 68) inside the hole in the upper diaphragm casing (key 63) or upper casing welding assembly (key 87) and over the lower spring guide (key 52). The spring should be sitting on top of the diaphragm plate (key 55).
23. Lubricate the bore on the top of the upper spring seat (key 69) where the adjusting screw (key 73) will make contact. Place the upper spring seat on top of the control spring (key 68).
24. Install the spring case (key 70) over the control spring (key 68) and upper spring seat (key 69) and on top of the spring case spacer (key 66) or upper casing welding assembly (key 87). Align the holes in the spring case with the holes in the spring case spacer or upper casing welding assembly while ensuring the vent assembly (key 26) is aligned with valve body inlet.
25. Lubricate cap screws (key 67) and use them to secure the spring case (key 70) to the spring case spacer (key 66) or upper casing welding assembly (key 87). Tighten the cap screws to a final torque of 25 to 28 ft-lbs / 34 to 38 N•m.



WARNING

Personal injury, equipment damage or leakage due to escaping fluid may result if adjusting screw (key 73) and jam nut (key 72) are not installed properly. Also, main spring (key 68) may go solid resulting in the backpressure regulator not opening if jam nut is not installed and adjusting screw is adjusted completely down.

26. Lubricate the adjusting screw (key 73) and thread on the jam nut (key 72). If a pressure-loaded actuator is used, install the sealing washer (key 71). Lubricate the adjusting screw and place it into the spring case (key 70). Thread the adjusting screw using a hand wrench (not an impact gun) until it touches the upper spring seat (key 69). Set the regulator to the desired set pressure according to the Adjustment procedure.

For High-Pressure Actuator Diaphragm Replacement

5. Remove the cap screws (key 57) and hex nuts (key 58) connecting the diaphragm casings (keys 62 and 63) and diaphragm (key 56). Lift off the upper diaphragm casing (key 63).
6. Unscrew the jam nuts (key 48, detail V) and remove them from the actuator stem (key 40).
7. Remove the Belleville spring washer (key 49) and lower spring seat (key 54) from the actuator stem (key 40).
8. Lift off the diaphragm (key 56) from the actuator stem (key 40) and inspect it for damage. Replace if necessary. If no further maintenance or inspection is required, proceed to step 15.

Note

Exercise care to ensure that the actuator stem (key 40) enters and exits the lower diaphragm head bore without pinching, cutting or damaging in any way the lower diaphragm head O-ring (key 51).

9. Carefully remove the lower diaphragm head (key 53) from the actuator stem (key 40). Replace the lower diaphragm head O-ring (key 51) if necessary.

10. If it is desired to replace the stem O-rings and bearings (keys 47 and 46, details X and Z), disconnect the control line tubing. Remove the lower diaphragm casing (key 62) by unthreading it from the adaptor (key 74). Remove stem (key 40) from the lower casing by pulling on the end of the stem without threads.
11. Remove the wiper ring (key 45, detail Z) on the threaded end of the lower diaphragm casing (key 62) to reach the bearing and stem O-ring (keys 46 and 47). Install the new stem O-ring and bearing and put back the wiper.
12. Turn the lower diaphragm casing (key 62) over and install another stem O-ring and bearing (keys 47 and 46) in the top side of the lower casing.
13. Lubricate the bore on both ends of the lower diaphragm casing (key 62). Install the lower casing over the actuator stem (key 40) and thread into the valve body (key 1). Tighten the lower casing into the body until the connecting pipe holes in the casing are located 90° from the valve body ends for correct tubing alignment. Do not loosen the bonnet thread to align the pipe holes. Always tighten the lower casing to make alignment for the control line.

Note

Position the lower diaphragm casing (key 62) such that the vent (key 26) is facing valve body (key 1) inlet, the lube fitting (key 44) is facing body outlet end and the 1/2 NPT control line connection (key 30) is located 90° from the valve body ends.

Note

Exercise care to ensure that the actuator stem (key 40) enters and exits the casing bore without pinching, cutting or damaging the actuator stem O-rings (key 47).

14. The serrated side of the lower diaphragm head (key 53) should be facing up toward the threaded end of the actuator stem (key 40). Carefully install the lower diaphragm head over the actuator stem.

Note

Exercise care to ensure that the actuator stem (key 40) enters and exits the lower diaphragm head bore without pinching, cutting or damaging in any way the lower diaphragm head O-ring (key 51).

15. Lubricate the convoluted side of the diaphragm (key 56) and place over the actuator stem (key 40) and on top of the lower diaphragm head (key 53). The convolutions of the diaphragm should be pointing up.
16. Place the lower spring seat (key 54) and Belleville spring washer (key 49) over the actuator stem (key 40) and on top of the diaphragm (key 56). The raised inner diameter of the spring washer should be pointing toward the threaded end of the actuator stem.
17. Lubricate the threads of the actuator stem (key 40) and thread the two jam nuts (key 48) onto it. Using wreckflats, hold the stem and torque the jam nuts individually. Tighten to a torque of 12 to 14 ft-lbs / 16 to 19 N•m.
18. Install the upper diaphragm casing (key 63) while aligning the bolt circle holes in the upper diaphragm casing, diaphragm (key 56) and lower diaphragm casing (key 62).

Note

Exercise care to ensure that the diaphragm (key 56) is not pinched, twisted or wrinkled while compressing between the upper and lower diaphragm casings (keys 62 and 63).

19. Lubricate the cap screws (key 57) and nuts (key 58) and carefully insert through holes in the outer flange of the diaphragm casings (keys 62 and 63) and diaphragm (key 56). Tighten the cap screws to the hex nuts to a final torque value of 45 to 55 ft-lbs / 61 to 75 N•m.
20. Place the control spring (key 68) inside the hole in the upper diaphragm casing (key 63) and over the lower spring seat (key 54). The spring should be sitting on top of the lower spring seat.
21. Lubricate the bore on the top of the upper spring seat (key 69) where the adjusting screw (key 73) will make contact. Place the upper spring seat on top of the control spring (key 68).

Type MR108

22. Install the spring case (key 70) over the control spring (key 68) and upper spring seat (key 69) and on top of the upper diaphragm casing (key 63). Align the holes in the spring case with the holes in the upper casing while ensuring the vent assembly (key 26) is aligned with valve body inlet.
23. Lubricate cap screws (key 67) and use to secure the spring case (key 70) to the spring case spacer (key 66). Tighten the cap screws to a final torque of 25 to 28 ft-lbs / 34 to 38 N•m.

WARNING

Personal injury, equipment damage or leakage due to escaping fluid may result if adjusting screw (key 73) and jam nut (key 72) are not installed properly. Also, spring (key 68) may go solid resulting in the backpressure regulator not opening if jam nut is not installed and adjusting screw is adjusted completely down.

24. Lubricate the adjusting screw (key 73) and thread on the jam nut (key 72). If a pressure-loaded actuator is used, install the sealing washer (key 71). Lubricate the adjusting screw and place it into the spring case (key 70). Thread the adjusting screw using a hand wrench (not an impact gun) until it touches the upper spring seat (key 69).

Regulator Reassembly

As indicated by the square callouts in Figure 4, it is recommended that a good quality pipe thread sealant be applied to pressure connections and fittings and a good quality lubricant be applied to O-rings. Also apply an anti-seize compound to the adjusting screw threads and other areas as needed.

After repair, the back pressure regulator should be tested for proper operation before being put back into service.

Parts Ordering

When corresponding with your local Sales Office about this regulator, always reference the equipment serial number or FS number found on the nameplate.

When ordering replacement parts, reference the key number of each needed part as found in the following parts list. Separate kits containing all recommended spare parts are available.

Parts List

WARNING

Use only genuine Fisher® replacement parts. Components that are not supplied by Emerson™. should not, under any circumstances, be used in any Fisher regulator, because they will void your warranty, might adversely affect the performance of the valve and could give rise to personal injury and property damage.

Note

In this parts list, parts marked NACE are intended for corrosion-resistant service as detailed in the NACE International Standard MR0175-2003 and MR0103.

| Key | Description | Part Number |
|-----|---|---------------------|
| | Elastomer Trim Parts kit (included are keys 4, 12, 14, 15, 17, 20 and 21) | |
| | Nitrile (NBR) | |
| | NPS 1 / DN 25 Body Size | RMR1058XN12 |
| | NPS 2 / DN 50 Body Size | RMR1058XN22 |
| | NPS 3 / DN 80 Body Size | RMR1058XN32 |
| | NPS 4 / DN 100 Body Size | RMR1058XN42 |
| | Elastomer Trim Parts kit (included are keys 4, 12, 14, 15, 17, 20 and 21) | |
| | Fluorocarbon (FKM) | |
| | NPS 1 / DN 25 Body Size | RMR1058XF12 |
| | NPS 2 / DN 50 Body Size | RMR1058XF22 |
| | NPS 3 / DN 80 Body Size | RMR1058XF32 |
| | NPS 4 / DN 100 Body Size | RMR1058XF42 |
| | Ethylene Propylene (EPDM) | |
| | NPS 1 / DN 25 Body Size | RMR1058XE12 |
| | NPS 2 / DN 50 Body Size | RMR1058XE22 |
| | NPS 3 / DN 80 Body Size | RMR1058XE32 |
| | NPS 4 / DN 100 Body Size | RMR1058XE42 |
| | Actuator Parts kit (keys 45 and 46 requires 2, key 47 requires 2, key 48 requires 2, keys 49, 51, 56 and 60 Low-Pressure Actuator only) | |
| | Nitrile (NBR) | |
| | Low-Pressure Actuator | RMR1058XNL2 |
| | High-Pressure Actuator | RMR1058XNH2 |
| | Fluorocarbon (FKM) | |
| | Low-Pressure Actuator | RMR1058XFL2 |
| | High-Pressure Actuator | RMR1058XFH2 |
| | Ethylene Propylene (EPDM) | |
| | Low Pressure Actuator | RMR1058XEL2 |
| | High-Pressure Actuator | RMR1058XEH2 |
| 1 | Valve Body | See following table |
| 2 | Body Flange | |
| | For NPS 1 / DN 25 Body Size | |
| | WCC Steel | GE39061X012 |
| | CF8M Stainless steel (NACE) | GE39061X022 |
| | CF3M Stainless steel (NACE) | GE39061X032 |
| | For NPS 2 / DN 50 Body Size | |
| | WCC Steel | GE39060X012 |
| | CF8M Stainless steel (NACE) | GE39060X022 |
| | CF3M Stainless steel (NACE) | GE39060X032 |
| | For NPS 3 / DN 80 Body Size | |
| | WCC Steel | GE39059X012 |
| | CF8M Stainless steel (NACE) | GE39059X022 |
| | CF3M Stainless steel (NACE) | GE39059X032 |

Key 1, Type MR108 Valve Bodies

| MATERIAL | END CONNECTION | BODY SIZE, NPS / DN | | | |
|-----------------------------|--------------------|---------------------|-------------|-------------|-------------|
| | | 1 / 25 | 2 / 50 | 3 / 80 | 4 / 100 |
| Cast Iron | NPT | 34B7611X012 | 38A8845X012 | ----- | ----- |
| | CL125 FF | 34B8630X012 | 38A8847X012 | 38A8851X012 | 38A8865X012 |
| | CL250 RF | 37B5950X012 | 38A8846X012 | 38A8850X012 | 38A8854X012 |
| WCC Steel | NPT | 37B5946X012 | 38A8848X012 | ----- | ----- |
| | CL150 RF | 37B5947X012 | 38A8853X012 | 38A8872X012 | 38A8867X012 |
| | CL300 RF | 37B5948X012 | 38A8849X012 | 38A8871X012 | 38A8869X012 |
| | CL600 RF | 37B5949X012 | 38A8844X012 | 38A8852X012 | 38A8866X012 |
| | DIN PN 16/25/40 RF | GE05956X012 | GE05960X012 | GE05965X012 | GE05969X012 |
| CF8M Stainless steel (NACE) | NPT | 37B5946X032 | 38A8848X032 | ----- | ----- |
| | CL150 RF | 37B5947X032 | 38A8853X072 | 38A8872X052 | 38A8867X042 |
| | CL300 RF | 37B5948X032 | 38A8849X032 | 38A8871X052 | 38A8869X032 |
| | CL600 RF | 37B5949X032 | 38A8844X032 | 38A8852X042 | 38A8866X032 |
| | DIN PN 16/25/40 RF | GE05956X022 | GE05960X022 | GE05965X022 | GE05969X022 |
| CF3M Stainless steel (NACE) | CL150 RF | 37B5947X102 | 38A8853X082 | ----- | ----- |
| | CL300 RF | 37B5948X102 | 38A8849X122 | 38A8871X122 | ----- |
| WCC Steel (NACE) | NPT | 37B5946X022 | 38A8848X022 | ----- | ----- |
| | CL150 RF | 37B5947X022 | 38A8853X052 | 38A8872X062 | 38A8867X032 |
| | CL300 RF | 37B5948X022 | 38A8849X022 | 38A8871X042 | 38A8869X022 |
| | CL600 RF | 37B5949X022 | 38A8844X022 | 38A8852X032 | 38A8866X022 |

| Key | Description | Part Number | Key | Description | Part Number |
|-----|--|--|-----|--|--|
| 2 | Body Flange (continued) For NPS 4 / DN 100 Body Size WCC Steel CF8M Stainless steel (NACE) | GE39058X012 GE39058X022 | 12* | Port Seal (NACE) For NPS 1 / DN 25 Body Size Nitrile (NBR) Fluorocarbon (FKM) | 14A6788X012 14A8186X012 |
| 3 | Stud Bolt For NPS 1 / DN 25 Body Size (4 required) Steel Stainless steel (NACE) For NPS 2 / DN 50 Body Size (8 required) Steel Stainless steel (NACE) For NPS 3 / DN 80 Body Size (8 required) Steel Stainless steel (NACE) For NPS 4 / DN 100 Body Size (8 required) Steel Stainless steel (NACE) | 1R2848X0752 1R284835222 1K2429X0782 1K242935222 1A3781X0562 1A378135222 1R3690X0592 1R369035222 | | For NPS 2 / DN 50 Body Size Nitrile (NBR) Fluorocarbon (FKM) For NPS 3 / DN 80 Body Size Nitrile (NBR) Fluorocarbon (FKM) For NPS 4 / DN 100 Body Size Nitrile (NBR) Fluorocarbon (FKM) Ethylene Propylene (EPDM) NPS 1 / DN 25 Body Size NPS 2 / DN 50 Body Size NPS 3 / DN 80 Body Size NPS 4 / DN 100 Body Size | 24A5673X012 25A7412X012 24A5658X012 25A7375X012 24A5643X012 25A7469X012 14A6788X022 24A5673X062 24A5658X062 24A5643X052 |
| 4* | Gasket (NACE) Composition For NPS 1 / DN 25 Body Size For NPS 2 / DN 50 Body Size For NPS 3 / DN 80 Body Size For NPS 4 / DN 100 Body Size | 14A6785X012 14A5685X012 14A5665X012 14A5650X012 | 13* | Seat Ring For NPS 1 / DN 25 Body Size 410/416 Stainless steel 316 Stainless steel (NACE) 316L Stainless steel (NACE) For NPS 2 / DN 50 Body Size 410/416 Stainless steel 316 Stainless steel (NACE) 316L Stainless steel (NACE) For NPS 3 / DN 80 Body Size 410/416 Stainless steel 316 Stainless steel (NACE) 316L Stainless steel (NACE) For NPS 4 / DN 100 Body Size 410/416 Stainless steel 316 Stainless steel (NACE) 316L Stainless steel (NACE) | 24A6781X012 24A6781X022 24A6781X052 24A5670X012 24A5670X022 24A5670X042 24A5655X012 24A5655X022 24A5655X042 |
| 9 | Valve Spring (NACE) Inconel® X750 For NPS 1 / DN 25 Body Size For NPS 2 / DN 50 Body Size For NPS 3 / DN 80 Body Size For NPS 4 / DN 100 Body Size | 11B6769X012 16A5501X012 16A5503X012 16A5506X012 | 14* | Piston Ring (NACE) PTFE For NPS 1 / DN 25 Body Size For NPS 2 / DN 50 Body Size For NPS 3 / DN 80 Body Size For NPS 4 / DN 100 Body Size | 14A6786X012 14A5675X012 14A5660X012 14A5645X012 |
| 11 | Cage (NACE) For NPS 1 / DN 25 Body Size CF3M/CF8M Stainless steel For NPS 2 / DN 50 Body Size For Quick Open Cage Type For Quick Open, Reduced Capacity Cage Type For NPS 3 / DN 80 Body Size CF3M/CF8M Stainless steel For NPS 4 / DN 100 Body Size CF3M/CF8M Stainless steel | GF03315X012 GF03319X012 GG00814X012 GF03311X012 GF03314X012 | | | |

*Recommended spare part.
Inconel® is a mark owned by Special Metals Corporation.

Type MR108

| Key | Description | Part Number | Key | Description | Part Number |
|-----|---|--|-----|--|---|
| 15* | Upper Seal (NACE) For NPS 1 / DN 25 Body Size Nitrile (NBR) Fluorocarbon (FKM) For NPS 2 / DN 50 Body Size Nitrile (NBR) Fluorocarbon (FKM) For NPS 3 / DN 80 Body Size Nitrile (NBR) Fluorocarbon (FKM) For NPS 4 / DN 100 Body Size Nitrile (NBR) Fluorocarbon (FKM) Ethylene Propylene (EPDM) NPS 1 / DN 25 Body Size NPS 2 / DN 50 Body Size NPS 3 / DN 80 Body Size NPS 4 / DN 100 Body Size | 14A6789X012 14A8187X012 24A5674X012 25A7413X012 24A5659X012 25A7376X012 24A5644X012 25A7468X012 14A6789X022 24A5674X062 24A5659X062 24A5644X052 | 21* | Adaptor O-ring (NACE) For NPS 1 / DN 25 Body Size Nitrile (NBR) Fluorocarbon (FKM) For NPS 2, 3 and 4 / DN 50, 80 and 100 Body Sizes Nitrile (NBR) Fluorocarbon (FKM) Ethylene Propylene (EPDM) NPS 1 / DN 25 Body Size NPS 2, 3 and 4 / DN 50, 80 and 100 Body Sizes 24 Drive Screw (NACE) (6 required) 18-8 Stainless steel 25 Flow Arrow (NACE) 18-8 Stainless steel 26 Vent Assembly (NACE), Type Y602-12 (2 required/ 1 required for Pressure-Loaded Actuator) 29 Hex Nut For NPS 1 / DN 25 Body Size (4 required) Steel Stainless steel (NACE) For NPS 2 / DN 50 Body Size (8 required) Steel Stainless steel (NACE) For NPS 3 / DN 80 Body Size (8 required) Steel Stainless steel (NACE) For NPS 4 / DN 100 Body Size (8 required) Steel Stainless steel (NACE) 30 Pipe Plug, 1/2 NPT Steel Stainless steel (NACE) 33 NACE Tag, 18-8 Stainless steel 34 Wire Seal, 304 Stainless steel (NACE) 38 Pipe Plug, 1/4 NPT Steel Stainless steel (NACE) 39 Pipe Plug, 1/2 NPT For All Body Sizes Zinc 316 Stainless steel (NACE) For NPS 1, 2 and 3 / DN 25, 50 and 80 Body Sizes 316L Stainless steel (NACE) 40 Stem Actuator For NPS 1 / DN 25 Body Size S17400 Stainless steel S20910 Stainless steel (NACE) For NPS 1 / DN 25 Body Size For NPS 2 / DN 50 Body Size S17400 Stainless steel S20910 Stainless steel (NACE) For NPS 3 / DN 80 Body Size S17400 Stainless steel S20910 Stainless steel (NACE) For NPS 4 / DN 100 Body Size S17400 Stainless steel S20910 Stainless steel (NACE) 41 Flange Nut S17400 Stainless steel S20910 Stainless steel (NACE) 43 Nameplate 44 Lube Fitting (NACE) Carbon-plated steel 45 Wiper Ring (NACE) 46* Bearing (NACE) (2 required) Nylon (PA) Nyliner 47* Valve Stem O-ring (NACE) (2 required) Nitrile (NBR) Fluorocarbon (FKM) Ethylene Propylene (EPDM) | 10A8931X012 10A0811X012 10A3800X012 1R727606382 10A8931X022 10A3800X042 1A368228982 ----- Y602X1-A12 1C3306X0832 1C330635252 1A3772X0892 1A377235252 1A3760X0832 1A376035252 1A3520X0922 1A352035252 1A369224492 1A369235072 ----- 1U7581X0022 1A767524662 1A767535072 1A398524182 1A398535072 1A398535082 GE39105X012 GE39105X022 GE39106X012 GE39106X022 GE39107X012 GE39107X022 GE39108X012 GE39108X022 GG01972X012 GG01972X022 ----- 1L847828992 15A6002XN12 17A7112X012 17A7112X022 1C782206992 1K756106382 1C7822X0052 |
| 16 | Valve Plug For NPS 1 / DN 25 Body Size 416 Stainless steel 316 Stainless steel (NACE) 316L Stainless steel (NACE) For NPS 2 / DN 50 Body Size 416 Stainless steel 316 Stainless steel (NACE) 316L Stainless steel (NACE) For NPS 3 / DN 80 Body Size 416 Stainless steel 316 Stainless steel (NACE) 316L Stainless steel (NACE) For NPS 4 / DN 100 Body Size 416 Stainless steel 316 Stainless steel (NACE) 316L Stainless steel (NACE) | GE39093X012 GE39093X022 GE39093X032 GE39094X012 GE39094X022 GE39094X032 GE39095X012 GE39095X022 GE39095X032 GE39096X012 GE39096X022 GE39096X032 | 31 | Stainless steel (NACE) For NPS 3 / DN 80 Body Size (8 required) Steel Stainless steel (NACE) For NPS 4 / DN 100 Body Size (8 required) Steel Stainless steel (NACE) | 1A3772X0892 1A377235252 1A3760X0832 1A376035252 1A3520X0922 1A352035252 |
| 17* | Cage O-ring (NACE) For NPS 1 / DN 25 Body Size Nitrile (NBR) Fluorocarbon (FKM) For NPS 2 / DN 50 Body Size Nitrile (NBR) Fluorocarbon (FKM) For NPS 3 / DN 80 Body Size Nitrile (NBR) Fluorocarbon (FKM) For NPS 4 / DN 100 Body Size Nitrile (NBR) Fluorocarbon (FKM) Ethylene Propylene (EPDM) NPS 1 / DN 25 Body Size NPS 2 / DN 50 Body Size NPS 3 / DN 80 Body Size NPS 4 / DN 100 Body Size | 10A7777X012 10A7778X012 10A7779X012 10A7779X022 14A5688X012 14A5688X022 10A3481X012 10A3483X012 10A7777X022 10A7779X052 14A5688X082 10A3481X052 | 42 | Stainless steel (NACE) For NPS 1 / DN 25 Body Size S17400 Stainless steel S20910 Stainless steel (NACE) For NPS 2 / DN 50 Body Size S17400 Stainless steel S20910 Stainless steel (NACE) For NPS 3 / DN 80 Body Size S17400 Stainless steel S20910 Stainless steel (NACE) For NPS 4 / DN 100 Body Size S17400 Stainless steel S20910 Stainless steel (NACE) | 1A398524182 1A398535072 1A398535082 GE39105X012 GE39105X022 GE39106X012 GE39106X022 GE39107X012 GE39107X022 GE39108X012 GE39108X022 |
| 20* | Valve Plug O-ring (NACE) For NPS 1 / DN 25 Body Size Nitrile (NBR) Fluorocarbon (FKM) For NPS 2 / DN 50 Body Size Nitrile (NBR) Fluorocarbon (FKM) For NPS 3 / DN 80 Body Size Nitrile (NBR) Fluorocarbon (FKM) For NPS 4 / DN 100 Body Size Nitrile (NBR) Fluorocarbon (FKM) Ethylene Propylene (EPDM) NPS 1 / DN 25 Body Size NPS 2 / DN 50 Body Size NPS 3 / DN 80 Body Size NPS 4 / DN 100 Body Size | 14A6981X012 14A8188X012 14A5686X012 14A5686X022 1V326906562 1V3269X0042 14A5688X012 14A5688X022 14A6981X032 14A5686X052 1V3269X0062 14A5688X082 | 46 | Nylon (PA) Nyliner 47* Valve Stem O-ring (NACE) (2 required) Nitrile (NBR) Fluorocarbon (FKM) Ethylene Propylene (EPDM) | 17A7112X012 17A7112X022 1C782206992 1K756106382 1C7822X0052 |

* Recommended spare part.

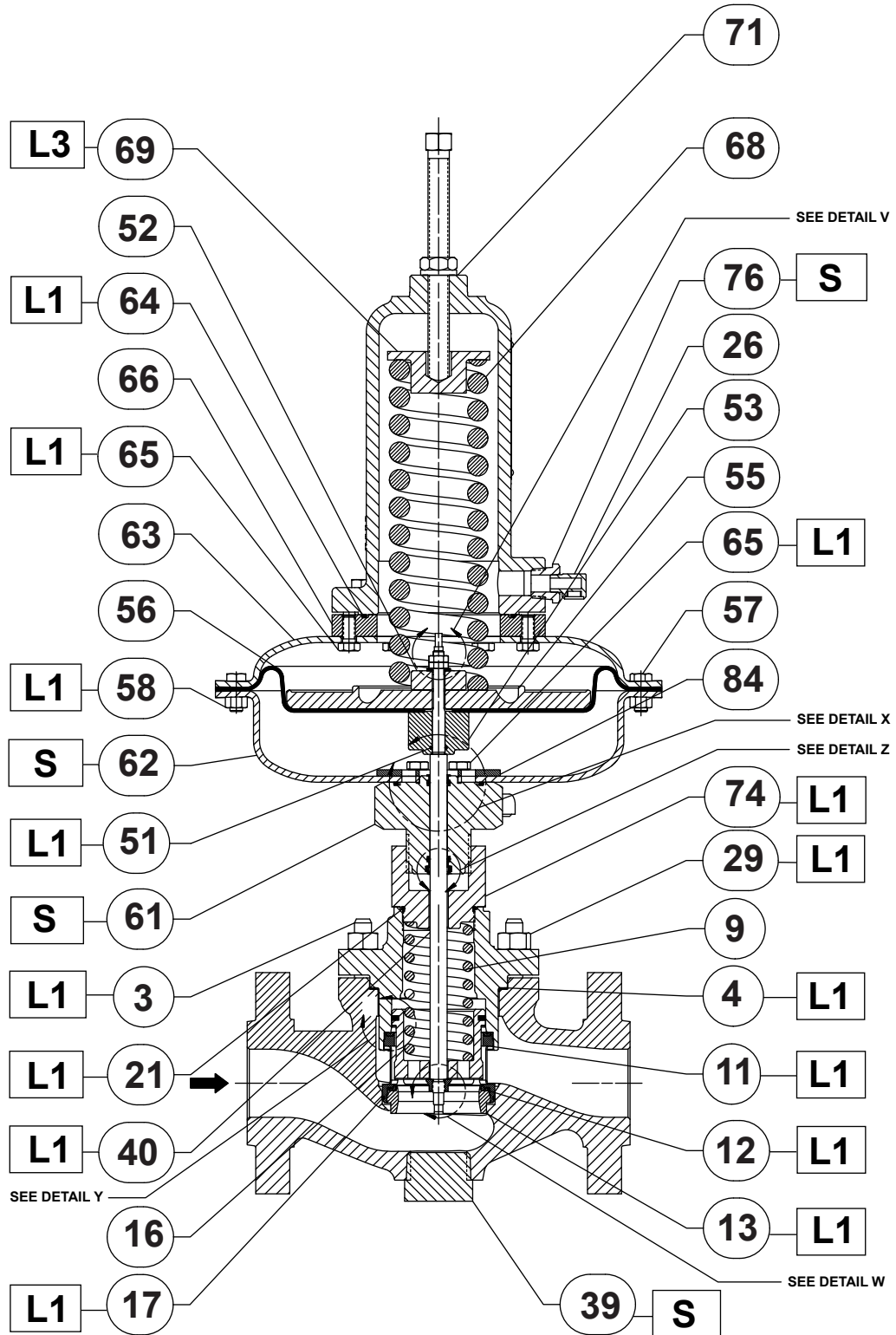

GE38436

NOTE: KEYS 64 AND 71 ARE USED ONLY FOR PRESSURE-LOADED ACTUATORS.

- APPLY LUBRICANT OR SEALANT⁽¹⁾:
 - L1 = MULTI-PURPOSE POLYTETRAFLUOROETHYLENE (PTFE) LUBRICANT
 - L3 = ANTI-SEIZE COMPOUND
 - S = MULTI-PURPOSE PTFE THREAD SEALANT

1. Lubricants and sealants must be selected such that they meet the temperature requirements.

Figure 4. Type MR108 Direct-Operated Backpressure Regulator Assemblies

Type MR108

| Key | Description | Part Number | Key | Description | Part Number |
|-----|---|-------------|-----|---|-------------|
| 48* | Jam Nut (NACE) (2 required) Zinc-plated steel | 1A946324122 | 64* | Upper Casing O-ring (For Low and High-Pressure Actuator) | |
| 49* | Belleville Spring Washer (NACE) | GG04933X012 | | Nitrile (NBR) | 1P233206992 |
| 51* | Lower Diaphragm Head O-ring (NACE) Nitrile (NBR) | 1P420706992 | | Fluorocarbon (FKM) | 1P2332X0012 |
| | Fluorocarbon (FKM) | 1L949306382 | 65 | Cap Screw (10 required) | |
| | Ethylene Propylene (EPDM) | 1P4207X0032 | | Steel | 1A368424052 |
| 52 | Lower Spring Guide (NACE) ⁽¹⁾ Zinc-plated steel | GE39171X012 | | Stainless steel (NACE) | 1A3684X0102 |
| 53 | Lower Diaphragm Head (NACE) S17400 Stainless steel | | 66 | Spring Case Spacer | |
| | For Low-Pressure Actuator | GE39137X012 | | Steel | GG00877X012 |
| | For High-Pressure Actuator | GG02195X012 | | Stainless steel (NACE) | GG00877X022 |
| 54 | Lower Spring Seat (NACE) ⁽¹⁾ Zinc-plated steel | GE39174X012 | 67 | Cap Screw (6 required) | |
| 55 | Diaphragm Plate (NACE) ⁽¹⁾ Cast Iron | GG02994X012 | | Steel | 1C4038X0062 |
| 56* | Diaphragm (NACE) For Low-Pressure Actuator | | | Stainless steel (NACE) | 1C4038X0032 |
| | Nitrile (NBR)/Nylon (PA) | GG02995X012 | 68 | Control Spring, Steel Alloy ⁽¹⁾ | |
| | Fluorocarbon (FKM)/Nylon (PA) | GG02995X022 | | For Low-Pressure Actuator | |
| | Ethylene Propylene (EPDM) | GG02995X052 | | 5 to 14 psig / 0.35 to 0.97 bar, White | GE42909X012 |
| | For High-Pressure Actuator | | | 8 to 24 psig / 0.55 to 1.7 bar, Silver | GE42910X012 |
| | Nitrile (NBR)/Nylon (PA) | GE39329X012 | | 12 to 30 psig / 0.83 to 2.1 bar, Orange | GE42911X012 |
| | Fluorocarbon (FKM)/Nomex® | GE39329X022 | | 15 to 35 psig / 1.0 to 2.4 bar, Red | GE43002X012 |
| | Ethylene Propylene (EPDM) | GE39329X052 | | For High-Pressure Actuator | |
| 57 | Cap Screw For Low-Pressure Actuator (16 required) | | | 25 to 40 psig / 1.7 to 2.8 bar, Blue | GE42906X012 |
| | Steel | 1E7603X0062 | | 35 to 70 psig / 2.4 to 4.8 bar, Green | GE42907X012 |
| | Stainless steel (NACE) | 1E7603X0072 | | 55 to 120 psig / 3.8 to 8.3 bar, White | GE42909X012 |
| | For High-Pressure Actuator (8 required) | | | 90 to 200 psig / 6.2 to 13.8 bar, Silver | GE42910X012 |
| | Steel | T10990X0012 | | 175 to 300 psig / 12.1 to 20.7 bar, Red | GE43002X012 |
| | Stainless steel (NACE) | 1A219235222 | 69 | Upper Spring Seat (NACE) ⁽¹⁾ | |
| 58 | Hex Nut For Low-Pressure Actuator (16 required) | | | Zinc-plated steel | GG02175X012 |
| | Steel | 1A3465X0092 | 70 | Spring Case | |
| | Stainless steel (NACE) | 1A3465X0102 | | Steel | GG00917X012 |
| | For High-Pressure Actuator | | | Stainless steel (NACE) | GG00917X022 |
| | Steel (8 required) | 1E9445X0502 | 71* | Sealing Washer | |
| | Stainless steel (16 required) (NACE) | 1A337435252 | | Steel/Nitrile (NBR) | 11A9681X012 |
| 60* | Bonnet O-ring (NACE) Nitrile (NBR) | 1F358106992 | | Steel/Fluorocarbon (FKM) | 11A9681X022 |
| | Fluorocarbon (FKM) | 1F3581X0022 | 72 | Jam Nut (NACE) | |
| 61 | Bonnet | | | Steel | 1A319224122 |
| | Steel | 33B0301X012 | | Stainless steel | 1A3192X0012 |
| | Stainless steel (NACE) | 33B0301X072 | 73 | Square Head Adjusting Screw (NACE) | |
| 62 | Lower Diaphragm Casing For Low-Pressure Actuator | | | Steel | GG03609X012 |
| | Steel | 24A5680X012 | | Stainless steel | GG03609X022 |
| | Stainless steel (NACE) | 24A5680X072 | 74 | Adaptor | |
| | High-Pressure Actuator | | | For NPS 1 / DN 25 Body Size | |
| | Steel | GG00833X012 | | Steel | GG03677X012 |
| | CF3M/CF8M Stainless steel (NACE) | GG00833X022 | | Stainless steel (NACE) | GG03677X022 |
| | High-Pressure Actuator with 1/8 NPT Tap for Bleed Valve (optional) | | | For NPS 2, 3 and 4 / DN 50, 80 and 100 Body Sizes | |
| | Steel | ERSA01471A0 | | Steel | GG03679X012 |
| | CF3M/CF8M Stainless steel (NACE) | ERSA01471A1 | | Stainless steel (NACE) | GG03679X022 |
| 63 | Upper Diaphragm Casing For Low-Pressure Actuator | | 76 | Pipe Bushing | |
| | Steel | GG02988X012 | | Steel | 1C379026232 |
| | Stainless steel (NACE) | GG02988X022 | | Stainless steel (NACE) | 1C3790X0012 |
| | For High-Pressure Actuator | | 81 | Pipe Nipple (NACE) | |
| | Steel | GG00884X012 | | Stainless steel | 1C488238982 |
| | Stainless steel (NACE) | GG00884X022 | 82 | Drain Valve (NACE) | |
| | | | | Stainless steel | 13B2392X082 |
| | | | 84 | Internal Stiffener Plate | |
| | | | | Steel | ERSA00169A0 |
| | | | | 316 Stainless steel (NACE) | ERSA00169A1 |
| | | | 85 | Bleed Valve, Stainless steel (NACE) (see Figure 3), 1/8 NPT | 15A6011XDG2 |
| | | | 87 | Upper Casing Welding Assembly (Low-Pressure Actuator only) (not shown) | |
| | | | | Steel | ERSA02584A0 |
| | | | | Stainless Steel | ERSA02584A1 |

* Recommended spare part.

Nomex® is a mark owned by E.I. du Pont de Nemours and Co.

1. Meets chemical and physical requirements of NACE MR0175-2003 and NACE MR103 for non-pressure loaded applications only. It is assumed that this part is not "exposed" to the sour gas.

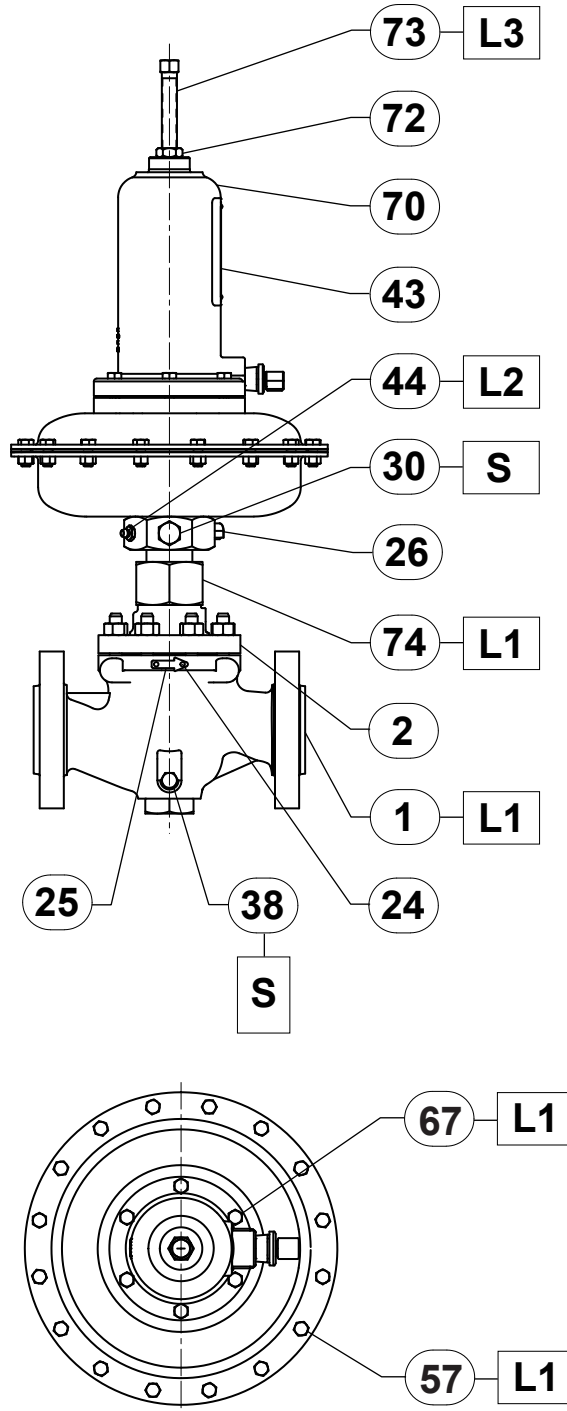

GE38436

- APPLY LUBRICANT OR SEALANT⁽¹⁾:**
L1 = MULTI-PURPOSE PTFE LUBRICANT
L2 = MULTI-PURPOSE NLGI⁽²⁾ GRADE 1 GREASE
L3 = ANTI-SEIZE COMPOUND
S = MULTI-PURPOSE PTFE THREAD SEALANT

1. Lubricants and sealants must be selected such that they meet the temperature requirements.
2. National Lubricating Grease Institute.

Figure 4. Type MR108 Direct-Operated Backpressure Regulator Assemblies (continued)

Type MR108

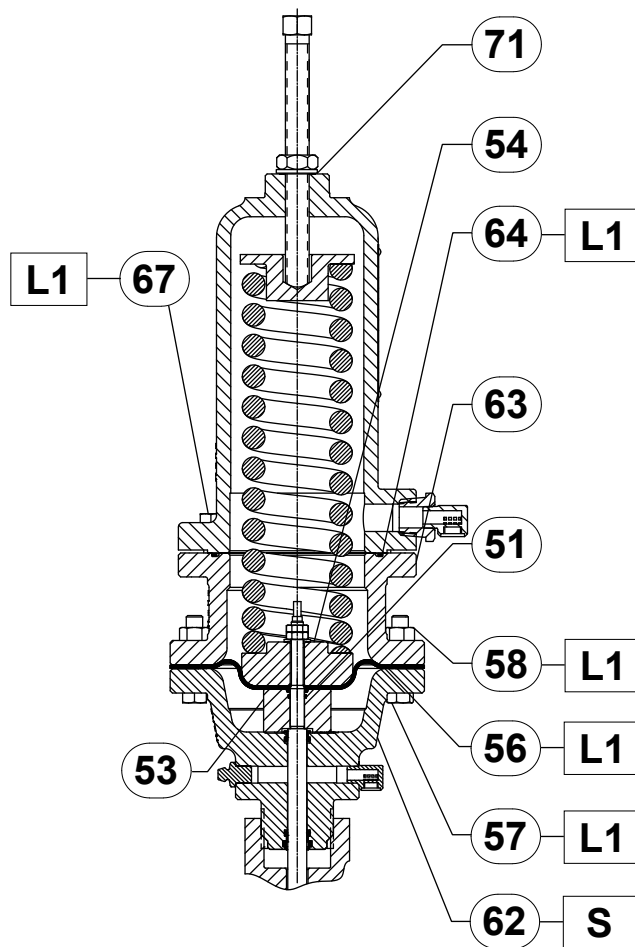

HIGH-PRESSURE ACTUATOR OPTION

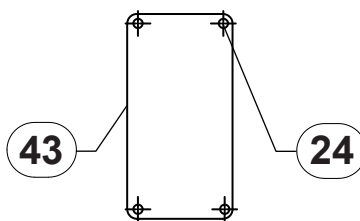

GE38436

NOTE: KEYS 64 AND 71 ARE USED ONLY FOR PRESSURE-LOADED ACTUATORS.

- APPLY LUBRICANT OR SEALANT⁽¹⁾:
 - L1 = MULTI-PURPOSE PTFE LUBRICANT
 - S = MULTI-PURPOSE PTFE THREAD SEALANT

1. Lubricants and sealants must be selected such that they meet the temperature requirements.

Figure 4. Type MR108 Direct-Operated Backpressure Regulator Assemblies (continued)

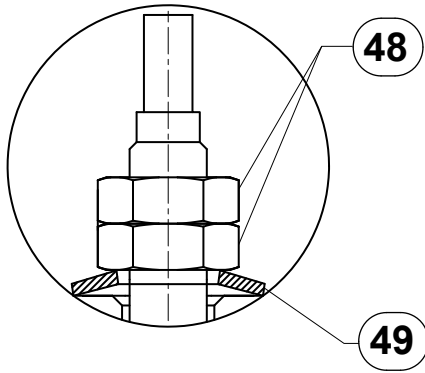

DETAIL V

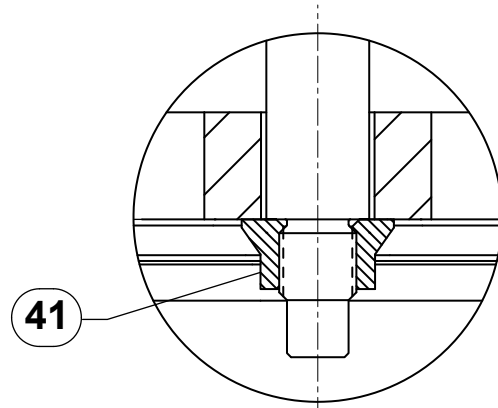

DETAIL W

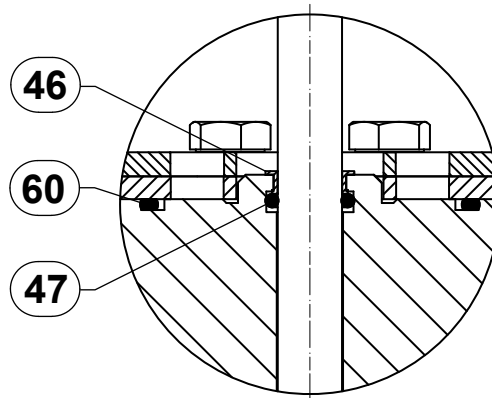

DETAIL X

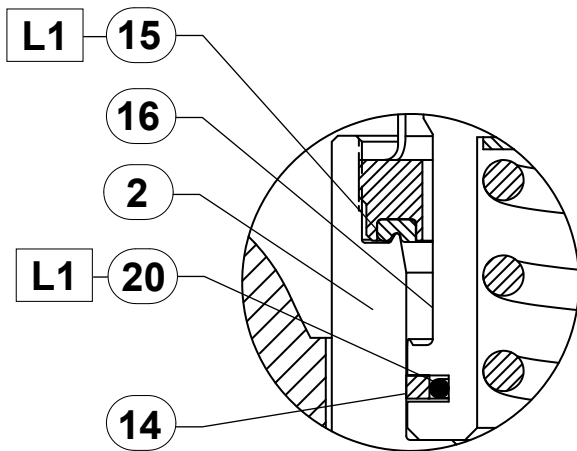

DETAIL Y

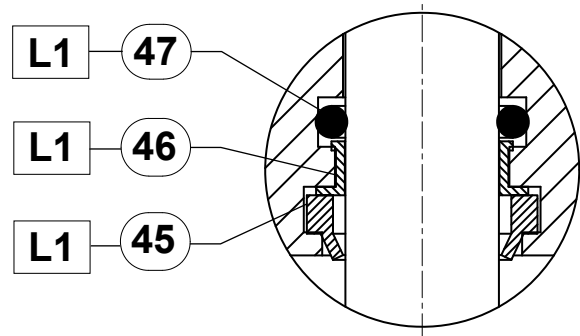

DETAIL Z

GE38436

□ APPLY LUBRICANT⁽¹⁾:
L1 = MULTI-PURPOSE PTFE LUBRICANT

1. Lubricants must be selected such that they meet the temperature requirements.

Figure 4. Type MR108 Direct-Operated Backpressure Regulator Assemblies (continued)

Type MR108

Industrial Regulators

Emerson Process Management Regulator Technologies, Inc.

USA - Headquarters
McKinney, Texas 75070 USA
Tel: +1 800 558 5853
Outside U.S. +1 972 548 3574

Asia-Pacific
Shanghai 201206, China
Tel: +86 21 2892 9000

Europe
Bologna 40013, Italy
Tel: +39 051 419 0611

Middle East and Africa
Dubai, United Arab Emirates
Tel: +971 4811 8100

Natural Gas Technologies

Emerson Process Management Regulator Technologies, Inc.

USA - Headquarters
McKinney, Texas 75070 USA
Tel: +1 800 558 5853
Outside U.S. +1 972 548 3574

Asia-Pacific
Singapore 128461, Singapore
Tel: +65 6770 8337

Europe
Bologna 40013, Italy
Tel: +39 051 419 0611
Chartres 28008, France
Tel: +33 2 37 33 47 00

Middle East and Africa
Dubai, United Arab Emirates
Tel: +971 4811 8100

TESCOM

Emerson Process Management Tescom Corporation

USA - Headquarters
Elk River, Minnesota 55330-2445, USA
Tels: +1 763 241 3238
+1 800 447 1250

Europe
Selmsdorf 23923, Germany
Tel: +49 38823 31 287

Asia-Pacific
Shanghai 201206, China
Tel: +86 21 2892 9499

For further information visit www.fisherregulators.com

The Emerson logo is a trademark and service mark of Emerson Electric Co. All other marks are the property of their prospective owners. Fisher is a mark owned by Fisher Controls International LLC, a business of Emerson Process Management.

The contents of this publication are presented for informational purposes only, and while every effort has been made to ensure their accuracy, they are not to be construed as warranties or guarantees, express or implied, regarding the products or services described herein or their use or applicability. We reserve the right to modify or improve the designs or specifications of such products at any time without notice.

Emerson Process Management Regulator Technologies, Inc. does not assume responsibility for the selection, use or maintenance of any product. Responsibility for proper selection, use and maintenance of any Emerson Process Management Regulator Technologies, Inc. product remains solely with the purchaser.