



COMPACT REFRIGERATOR

OWNER'S MANUAL **CR188WE/CR185E**

Visit our Web site at www.emersonradio.com

UNAUTHORIZED MODIFICATIONS TO THIS DEVICE COULD VOID MANUFACTURER'S WARRANTY.

THIS PAGE INTENTIONALLY LEFT BLANK

IMPORTANT SAFETY INSTRUCTIONS

Please follow the precautions below for your new refrigerator:

1. This refrigerator must be properly installed and located in accordance with the Installation Instructions before it is used.
2. Do not allow children to climb, stand or hang on the shelves in the refrigerator. They could damage the refrigerator and seriously injure themselves.
3. Do not store or use gasoline or other flammable vapors and liquids in the vicinity of this or any other appliance.
4. Keep fingers out of the clearances between the doors and cabinet. Be careful closing doors when children are in the area.
5. Unplug the refrigerator before cleaning and making repairs.
6. We strongly recommend that any servicing be performed by a qualified individual.
7. Turning the temperature control dial to the "0" position stops cooling but does not shut off power to the refrigerator.
8. Do not leave refrigerator in extreme cold or warm temperatures.
9. Do not place refrigerator near heat sources or open flames.
10. Clean the refrigerator with a soft, damp cloth. Remove stains with a mild soap. Do not clean the unit with industrial grade solvents, or abrasive chemicals.
11. Do not place heavy items on top of the refrigerator.
12. Never install the refrigerator where there is a lot of moisture and water can splash.
13. Do not allow children to hang on the doors; the refrigerator may be tipped over and hurt children.
14. Never eat spoiled food stored too long in the refrigerator or in an out-of-order refrigerator.
15. Do not use sharp tools inside the refrigerator - for example - to remove ice as damage may occur.
16. Unplug and remove food from the refrigerator if not used for a long period of time.

PROPER DISPOSAL

An empty refrigerator is an extremely dangerous attraction to children. If you are getting rid of your old refrigerator, please follow the instructions in the Child Entrapment Warning.

CHILD ENTRAPMENT WARNING:

Risk of child entrapment. Before you throw away your old refrigerator or freezer:

1. Take off the doors.
2. Leave the shelves in place so that children may not easily climb inside.

CAUTION: USE OF AN EXTENSION CORD IS NOT RECOMMENDED.

**FOR HOUSEHOLD USE ONLY
SAVE THESE INSTRUCTIONS**

GROUNDING INSTRUCTIONS

This appliance must be grounded. In the event of an electrical short circuit, grounding reduces the risk of electric shock by providing an escape wire for the electric current. This appliance is equipped with a cord having a grounding wire with a grounding plug. The plug must be inserted into an outlet that is properly installed and grounded.

WARNING: Improper use of the grounding plug can result in a risk of electric shock. Consult a qualified electrician or service person if the grounding instructions are not completely understood, or if doubt exists as to whether the appliance is properly grounded.

If it is necessary to use an extension cord, use only a three wire extension cord that has a three blade grounding plug, and a three slot receptacle that will accept the plug on the appliance. The marked rating of the extension cord should be equal to or greater than the electrical rating of the appliance.

INSTALLATION

1. Steady, flat location:

If the refrigerator is not leveled during installation, the doors may not close or seal properly, causing cooling, frost, or moisture problems. It is very important for the refrigerator to be level in order to function properly. To level your refrigerator, you may either turn the level leg clockwise to raise that side to the refrigerator or turn counter-clockwise to lower that side. Having someone push against the top of the refrigerator will take some weight off the leveling leg. This makes it easier to adjust the leveling leg.

2. Ventilation:

Do not block air vents. Place refrigerator approximately 5 inches from the wall to ensure proper airflow to the compressor. Do not place refrigerator near any heat resources such as a heater or stove as it will put a strain on the compressor.

3. Power supply:

- Check your local power source. This refrigerator requires a 110V-120V, 60Hz power supply.
- Use a receptacle that will accept the ground prong. The power cord of this appliance is equipped with a 3-prong (grounding) plug which mates with a standard 3-prong (grounding) wall outlet to minimize the possibility of electric shock hazard from this appliance.
 - (a) Longer cord sets or extension cords are available and may be used if care is exercised in their use.
 - (b) If a long cord or extension cord is used, (1) the marked electrical rating of the cord set or extension cord should be at least as great as the electrical rating of the appliance, (2) the extension cord must be a grounding-type 3-wire cord, and (3) the longer cord should be arranged so that it will not drape over the counter top or table top where it can be pulled on by children or tripped over unintentionally.

NOTES:

The refrigerator should always be plugged into its own individual electrical outlet which has a voltage rating that matches the rating plate.

If you have only a standard 2-prong wall outlet, it is your personal responsibility and obligation to have it replaced with a properly grounded 3-prong wall outlet.

Never unplug your refrigerator by pulling on the power cord. Always grip plug firmly and pull straight out from the outlet.

When using a 3-pronged plug

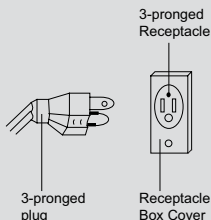

When using a grounding adapter, make sure the receptacle box is fully grounded.

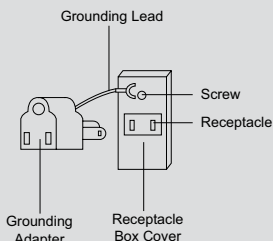

LOCATION OF CONTROLS

DOOR CLOSED

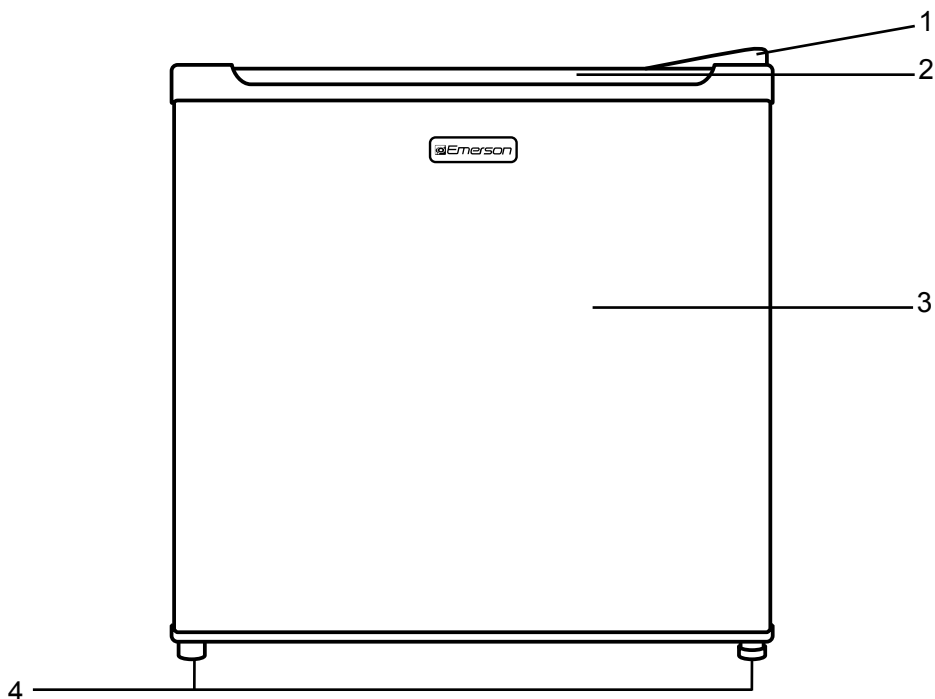

1. Top Hinge
2. The Handle
3. Refrigerator Door
4. Leveling Feet

LOCATION OF CONTROLS (CONTINUED)

DOOR OPEN

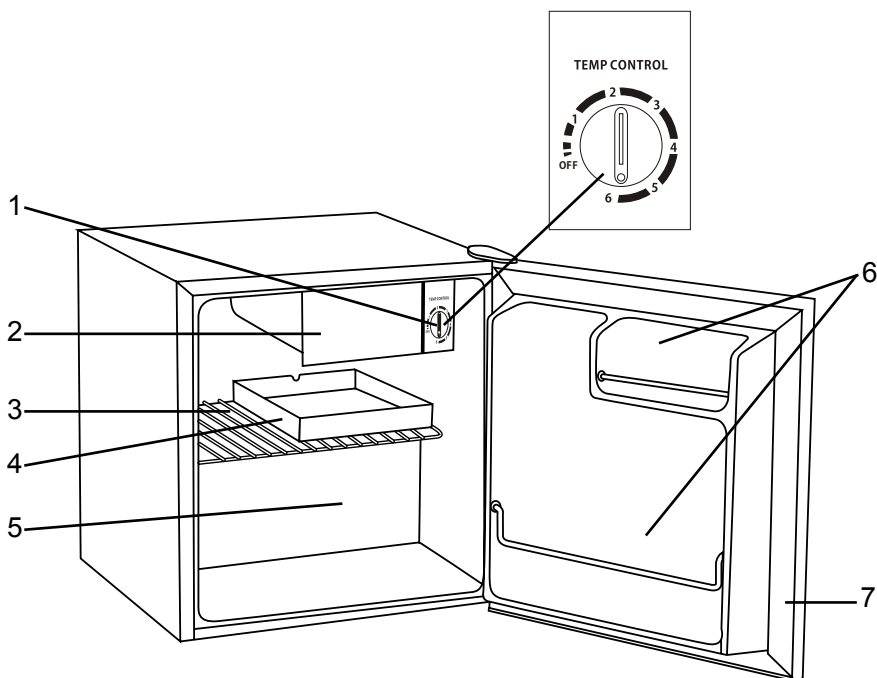

1. Thermostat Control Knob
2. Chiller Compartment
3. Wire Shelf
4. Drip Tray
5. Refrigerator Compartment
6. Bottle Storage
7. Door Gasket

OPERATION

NOTES: Temperature range of the chiller compartment is 30°F to 48°F at room temperature of 77°F (25°C). Ice cream and Popsicles must be kept cool at -5°F to 0°F, hence this chiller compartment is not suitable to store these types of items.

USING THE THERMOSTAT

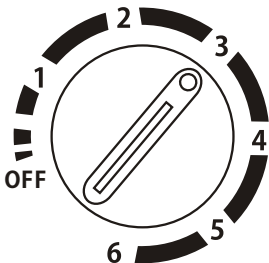
<p style="text-align: center;">TEMP CONTROL</p> 	<p>The thermostat control knob for the refrigerator and chiller is located beside the chiller compartment.</p> <p>The first time you turn the unit on, adjust the thermostat control knob to “3” and give your refrigerator time to cool down completely before adding food; a full 24 hours is recommended.</p> <p>After it is fully cooled, test it and adjust towards “1” to make less cool or towards “6” to cool more to best suit your needs. However, the setting of “3” should be appropriate for home or office refrigerator use.</p> <p>NOTE: Turning the thermostat control knob to the “OFF” position will stop the cooling cycle but does not shut off the power to the unit.</p>
--	---

DEFROSTING

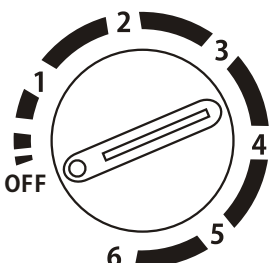
<p style="text-align: center;">TEMP CONTROL</p> 	<p>Defrosting process is manual:</p> <ol style="list-style-type: none">1. Turn the thermostat knob to the “OFF” position and leave the refrigerator door open.2. Remove all food from the chiller and refrigerator compartment.3. Clean and wipe out the melted frost with a cloth.4. After defrosting, turn thermostat knob to original position. <p>NOTE: If the chiller has accumulated excessive frost/ice, please do the following:</p> <ol style="list-style-type: none">1. Remove all food from the chiller and refrigerator compartment.2. Turn the thermostat knob to the “OFF” position and unplug from the outlet.3. Place towel under compact refrigerator or move refrigerator outdoors where no water damage can occur.4. Follow steps 3 & 4 from above section.
--	---

OPERATION (CONTINUED)

REVERSING THE DOOR POSITION

CAUTION:

To avoid to injury yourself and/or property, we recommend someone assist you during the door reversal process.

- Ensure the Appliance is unplugged and empty.
- Adjust the two leveling feet to their highest position.
- We recommend you have someone to assist you.

NOTE:

To take the door off it is necessary to tilt the Appliance backward. You should rest the Appliance on something solid, e.g. a chair just below the top panel.

DO NOT lay the Appliance completely flat as this may damage the coolant system.

TOOLS REQUIRED

- 10 mm socket screw driver
 - Phillips style screw driver
1. Upper Hinge Bracket
 2. Leveling foot

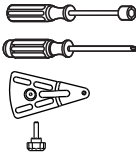

3. Machine Screw



4. Bottom Hinge Bracket



1

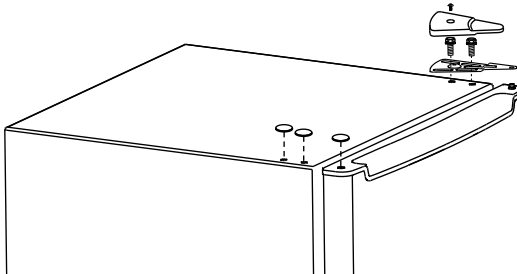

Unscrew the screw of top hinge cover, Remove the upper hinge cover, then unscrew the upper screws of metal hinge bracket and take off the hinge. Then take off the left side screw covers. Pull the appliance door upward to take it off.

2

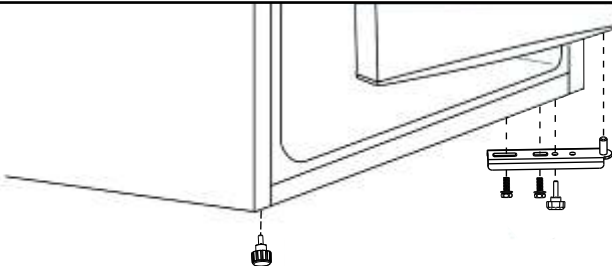

Remove left leveling foot and the bottom hinge bracket by unscrewing the mounting screws.

OPERATION (CONTINUED)

3



Install the leveling foot and the bottom hinge bracket on the new bottom side. Then tighten the screws of the bottom hinge bracket.

4

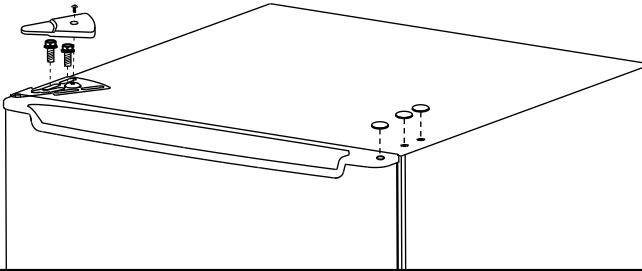

Slot the appliance door into the bottom hinge pin. Replace the upper hinge bracket on the new side and check the fitting between the door/ hinge moving smoothly. Then tighten the screws of the upper hinge bracket. Replace the hinge cover and the right side screw covers, tighten the screw of top hinge cover.

5

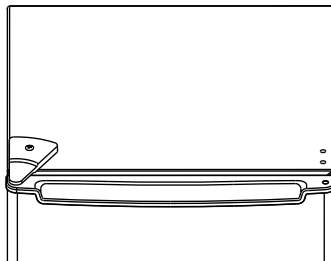

Check that the door is aligned horizontally and vertically and that the seals are closed on all sides before finally tightening the upper hinge. Re-adjust the leveling feet.

TROUBLE SHOOTING GUIDE

The refrigerator will not operate

- The power supply cord is unplugged.
- The thermostat knob is set to the "OFF" position.
- A household fuse or circuit breaker has tripped.

Food in the refrigerator compartment is freezing

- The thermostat knob is set too cold.
- The position of food stored touches the refrigerator back wall.

Food in the refrigerator compartment is not cold

- The air vents are blocked in the compartment; this prevents the movement of cold air.
- The door is opened too often or not closed properly.
- A large amount of food has just been added to the refrigerator or chiller compartment.
- The position of thermostat knob is adjusted too low.

The refrigerator seems to make unusual noise

- The refrigerator is not leveled on the floor.
- The body of the refrigerator touches a wall.
- The drip tray is not placed properly.

There is interior moisture build-up

- The air vents are blocked in the refrigerator.
- The door is opened too often or not closed properly.
- The room is humid.
- The food is not packaged correctly.

The door will not close completely

- Food packages are keeping the door from closing properly.
- The shelves are out of position
- The gaskets are dirty.
- The refrigerator is not level.

TECHNICAL SPECIFICATION

Unit Dimension (WxDxH) (inches)	17.4 x 18.9 x 19.5
Power Supply	AC115V~60Hz 90W
Current	1.5A
Power consumption per year	253 kwh

LIMITED WARRANTY

Emerson Radio Corp. warrants manufacturing defects in original material, including original parts and workmanship, under normal use and conditions, for a period of one year from the date of original purchase in the U.S. With your dated proof of purchase, we will provide repair service at no charge for labor and parts at an authorized Depot Repair Facility, or replace the product in our discretion. For repair or replacement, pack your unit in a padded box, enclose your check or money order payable to Emerson Radio Corp. in the amount of \$10.00 (not required by California residents) to cover shipping and handling costs, and enclose a copy of your proof of purchase. Send your unit to:

Emerson Returns Warehouse,
11500 Philadelphia Street,
Mira Loma Ca. 91752

AU898N

This warranty does not cover damage from negligence, misuse, abuse, accident, failure to follow operating instructions, commercial use, rental, repairs by an unauthorized facility, or products purchased, used, serviced or damaged outside of the United States.

THIS WARRANTY GIVES YOU SPECIFIC LEGAL RIGHTS AND YOU MAY ALSO HAVE OTHER RIGHTS WHICH VARY FROM STATE TO STATE.

The serial number can be found on the rear of the unit. We suggest that you record the serial number of your unit in the space below for future reference.

Model Number: CR188WE

Serial Number: _____



***** S E R V I C E *****

FOR ADDITIONAL SET-UP OR OPERATING ASSISTANCE
PLEASE CALL:
1-800-898-9020

FOR CUSTOMER SERVICE, PLEASE E-MAIL TO:
internet@emersonradio.com

OR WRITE TO:
Emerson Radio Corp.
Consumer Affairs Dept.
3 University Plaza,
Suite 405
Hackensack, NJ 07601

