

Portable CD-R/RW Player with AM/FM Stereo Radio and Cassette Recorder

OWNER'S MANUAL DTE288

Copyright 2005 Viacom International Inc. All Rights Reserved. Nickelodeon, Nick Jr., Nicktronic, Dora the Explorer and all related titles, characters and logos are trademarks of Viacom International Inc.

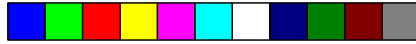

WARNING:

Choking Hazard – Small Parts and Packing Materials.

Not for children under 8 years.

- All materials for fastening or packing purposes are not part of the unit and should be discarded for children's safety.
- Please keep all information for future reference.
- This is not a toy.

CAUTION !

ELECTRICALLY OPERATED PRODUCT: Not recommended for children under 8 years old. As with all electric product, precautions should be observed during handling and use to prevent electric shock.

Ages 8+

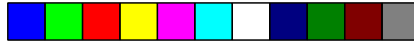

CAUTION

TO PREVENT FIRE OR SHOCK HAZARD, DO NOT USE THIS PLUG WITH AN EXTENSION CORD, RECEPTACLE OR OTHER OUTLET UNLESS THE BLADES CAN BE FULLY INSERTED TO PREVENT BLADE EXPOSURE. TO PREVENT FIRE OR SHOCK HAZARD, DO NOT EXPOSE THIS APPLIANCE TO RAIN OR MOISTURE.



The lightning flash with arrow-head symbol, within an equilateral triangle is intended to alert the user to the presence of uninsulated 'dangerous voltage' within the product's enclosure that may be of sufficient magnitude to constitute a risk of electric shock to persons.

CAUTION

RISK OF ELECTRIC SHOCK
DO NOT OPEN

WARNING: TO REDUCE THE RISK OF ELECTRIC SHOCK DO NOT REMOVE COVER (OR BACK), NO USER SERVICEABLE PARTS INSIDE REFER SERVICING TO QUALIFIED SERVICE PERSONNEL.



The exclamation point within an equilateral triangle is intended to alert the user to the presence of important operating and maintenance (servicing) instructions in the literature accompanying the appliance.

IMPORTANT SAFETY INSTRUCTIONS

- 1.) Read these instructions.
- 2.) Keep these instructions.
- 3.) Heed all warnings.
- 4.) Follow all instructions.
- 5.) Do not use this apparatus near water.
- 6.) Clean only with dry cloth.
- 7.) Do not block any ventilation openings. Install in accordance with the manufacturer's instructions.
- 8.) Do not install near any heat sources such as radiators, heat registers, stoves, or other apparatus (including amplifiers) that produce heat.
- 9.) Do not defeat the safety purpose of the polarized or grounding-type plug. A polarized plug has two blades with one wider than the other. A grounding type plug has two blades and a third grounding prong. The wide blade or the third prong is provided for your safety. If the provided plug does not fit into your outlet, consult an electrician for replacement of the obsolete outlet.
- 10.) Protect the power cord from being walked on or pinched particularly at plugs, convenience receptacles, and the point where they exit from the apparatus.
- 11.) Only use attachments / accessories specified by the manufacturer.
- 12.) Unplug this apparatus during lightning storms or when unused for long periods of time.
- 13.) Refer all servicing to qualified service personnel. Servicing is required when the apparatus has been damaged in any way, such as power-supply cord or plug is damaged, liquid has been spilled or objects have fallen into the apparatus, the apparatus has been exposed to rain or moisture, does not operate normally, or has been dropped.
- 14.) This appliance shall not be exposed to dripping or splashing water and no object filled with liquids such as vases shall be placed on the apparatus.
- 15.) Do not overload wall outlet. Use only power source as indicated.
- 16.) Use replacement parts as specified by the manufacturer.
- 17.) The product may be mounted to a wall only if recommended by the manufacturer.
- 18.) Upon completion of any service or repairs to this product, ask the service technician to perform safety checks.



Emerson Radio Corp. has produced this audio product under licence from Nickelodeon. We have taken great care to make sure your unit was in perfect working order when it left our factory.

It has been designed to give you many years of enjoyment and trouble free operation. Read this manual before operating this unit to become familiar with its features.

In the event you require technical assistance, please contact the Emerson Radio Customer Service hotline at 1-800-898-9020.

Retain this manual for future reference.



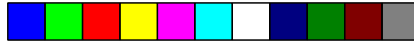

IMPORTANT NOTES

- Avoid installing this unit in places exposed to direct sunlight or close to heat radiating appliances such as electric heaters, on top of other stereo equipment that radiates too much heat, places lacking ventilation or dusty areas, places subject to constant vibration and/or humid or moist areas.
- Do not attempt to clean this unit with chemical solvents as this might damage the finish. Use a clean dry cloth.
- Operate controls and switches as described in the manual.
- Before turning 'On' the power, make certain that power cord is properly installed.
- Store your CDs, cassettes in a cool area to avoid damage from heat.
- When moving the set, be sure to first disconnect the power cord.

CLASS 1 LASER PRODUCT

CLASS 1 LASER PRODUCT
APPAREIL À LASER DE CLASSE 1
PRODUCTO LASER DE CLASE 1

CAUTION
INVISIBLE LASER RADIATION
WHEN OPEN AND INTERLOCKS
DEFEATED.
AVOID EXPOSURE TO BEAM



This product contains a low power Laser Device.

FCC Information

This equipment has been tested and found to comply with the limits for a Class B digital device, pursuant to Part 15 of the FCC Rules. These limits are designed to provide reasonable protection against harmful interference in a residential installation. This equipment generates, uses, and can radiate radio frequency energy and, if not installed and used in accordance with the instructions, may cause harmful interference to radio communications. However, there is no guarantee that interference will not occur in a particular installation. If this equipment does cause harmful interference to radio or television reception, which can be determined by turning the equipment off and on, the user is encouraged to try to correct the interference by one or more of the following measures:

- Reorient or relocate the receiving antenna.
- Increase the separation between the equipment and receiver.
- Connect the equipment into an outlet on a circuit different from that to which the receiver is connected.
- Consult the dealer or an experienced radio/TV technician for help.

This device complies with Part 15 of the FCC Rules. Operation is subject to the following two conditions:

- (1) This device may not cause harmful interference, and
- (2) This device must accept any interference received, including interference that may cause undesired operation.

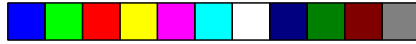

PREPARATION FOR USE

Unpacking and Set Up

- Carefully remove the unit from the carton and remove all packing materials from the unit.
- Carefully remove any small strips of tape which may have been used to keep the CD and Cassette doors closed during shipment.
- Open the CD compartment by lifting on the **OPEN** tab. Inside the CD compartment you will see a dummy CD protection card which is used to prevent the laser pick-up from moving during shipment. Carefully remove this card and close the CD compartment door.
- Please save the carton and packing materials in the event that your unit ever needs to be returned for service. The original carton and packing materials are the only way to protect the unit from damage during shipment.

Power Sources

This unit is designed to operate on 8 "C" batteries, not included, or on normal 120V 60Hz AC house current.

Operating this unit from any other power source may cause damage to the unit, and such damage is not covered by your warranty.



AC Operation

Connect the small end of the AC Power Cord to the AC socket on the back cabinet, then insert the plug in any convenient household 120V 60Hz AC outlet.

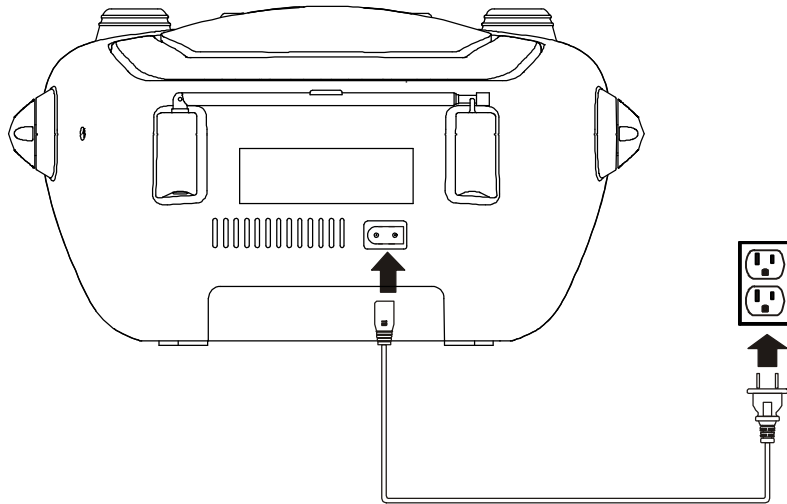

Note:

This unit has a polarized AC plug with one wide blade and one narrow blade. This plug will only fit into a matching polarized AC outlet. This is a safety feature to reduce the possibility of electric shock. If this plug will not fit in your AC outlet, you probably have an outdated non-polarized outlet. You should have your outdated outlet changed by a qualified, licensed electrician. Do not file the wide blade on the plug, or use an adapter to make the plug fit into your outlet. This defeats the safety feature and could expose you to electric shock.

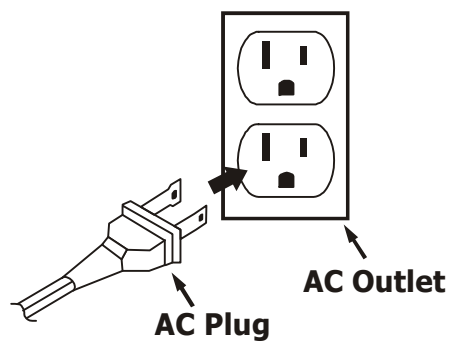

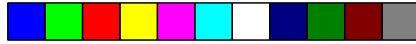

Battery Operation

- 1.) Remove the battery compartment door on the back of the cabinet by pressing down on the “≡” marks and slide it to open.

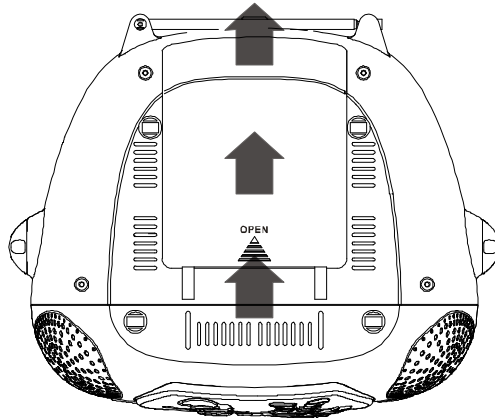

- 2.) Insert 8 “C” size batteries into the battery compartment according to the polarity diagram engraved inside the compartment. If the batteries are inserted incorrectly the unit will not work.

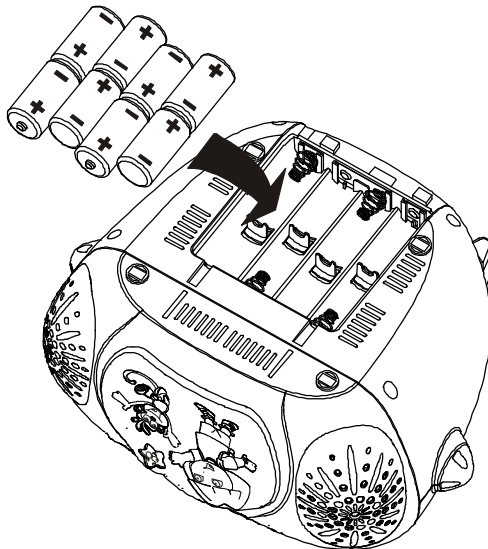

- 3.) Replace the battery compartment door.

Note: In order to operate the unit on battery power the AC cord must be disconnected from the AC socket on the back cabinet.

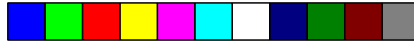











Battery Precautions

- Replacement of batteries must be done by an adult.
- Do not mix old and new batteries.
- Do not mix alkaline, standard (carbon-zinc) or rechargeable (nickel-cadmium) batteries.
- The supply terminals are not to be short-circuited.
- Non-rechargeable batteries are not to be recharged.
- Exhausted batteries are to be removed.
- Only batteries of the equivalent type are to be used.
- Batteries are to be inserted with the correct polarity.
- Dispose of batteries properly. Do not dispose of batteries in fire. The batteries may explode or leak.

Protect Your Furniture

This model is equipped with non-skid rubber 'feet' to prevent the product from moving when you operate the controls. These 'feet' are made from non-migrating rubber material specially formulated to avoid leaving any marks or stains on your furniture. However certain types of oil based furniture polishes, wood preservatives, or cleaning sprays may cause the rubber 'feet' to soften, and leave marks or a rubber residue on the furniture. To prevent any damage to your furniture we strongly recommend that you purchase small self-adhesive felt pads, available at hardware stores and home improvement centers everywhere, and apply these pads to the bottom of the rubber 'feet' before you place the product on fine wooden furniture.



- 1.) **Cassette Control Keys.**
(**PAUSE**  / **STOP-EJECT**  / **F.FWD**  / **REWIND**  / **PLAY** 
/ **RECORD** 
- 2.) **VOLUME** Control.
- 3.) **FUNCTION (RADIO / OFF-TAPE / CD)** Selector Switch.
- 4.) CD Door.
- 5.) AC Cord Socket (Back Cabinet).
- 6.) FM Telescopic Antenna.
- 7.) Battery Compartment (Bottom Cabinet).
- 8.) Carrying Handle.
- 9.) **PHONES** (Stereo Headphone) Jack.
- 10.) **BAND (AM / FM / FM ST.)** Selector Switch.
- 11.) **TUNING** Control.
- 12.) CD Door **OPEN** tab.
- 13.) Cassette Door.
- 14.) Speakers.
- 15.) **DORA** Phrase Button.
- 16.) CD **PROGRAM** Button.
- 17.) CD **REV.** Skip Search  Button.
- 18.) CD **FWD.** Skip Search  Button.
- 19.) **FM ST.** Indicator.
- 20.) **POWER** 'On' Indicator.
- 21.) CD Track LED Display.
- 22.) CD **REPEAT** Button.
- 23.) CD **STOP**  Button.
- 24.) CD **PLAY/PAUSE**  Button.



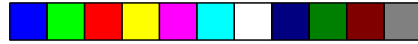

OPERATING INSTRUCTIONS

DORA Phrase Button

Press the **DORA** Button repeatedly in any mode to hear Dora phrases.

Listening To The Radio

- 1.) Move the **FUNCTION** selector to the **RADIO** position. The **POWER** indicator comes 'On'.
- 2.) Move the **BAND** selector to the desired band, **AM**, **FM** or **FM ST.**
- 3.) Tune to your desired station with the **TUNING** control. If you have set the **BAND** selector to **FM ST.** and you tune to a FM Stereo station the **FM ST.** LED Indicator will light.

***Note:** If you are listening to a weak FM Stereo station you can usually improve the reception by moving the **BAND** selector from the **FM ST.** position to the **FM** position, however the sound will now be mono.*

- 4.) Set the **VOLUME** control to the desired level.
- 5.) When you are finished listening move the **FUNCTION** selector back to the **OFF-TAPE** (Power Off) position to shut the power 'Off' and extend the battery life. The **POWER** indicator goes 'Off'.

Antenna Information

AM

The AM antenna is inside the cabinet. If AM reception is unsatisfactory try rotating the entire unit until you find the position that provides the best reception.

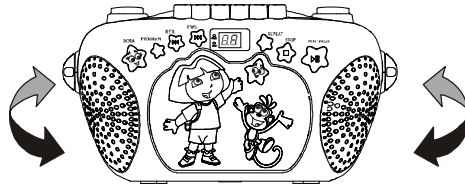

FM

Extend and vary the direction of the FM telescopic antenna to find the position that provides the best reception.

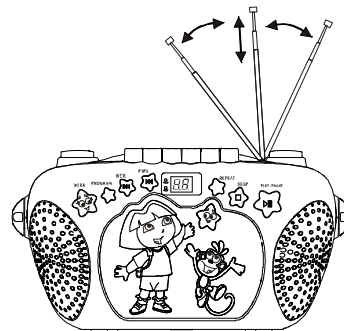

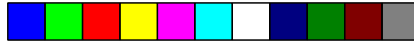

Playing Compact Discs

Note: Although this portable CD player can read CD-R and CD-RW discs, in addition to normal CDs, the playability of CD-R/RW discs may be affected by the type of software that was used to create the discs, as well as the quality and condition of the blank media you are using. 100% playability cannot be guaranteed. This is not an indication of a problem with the player.

Normal Playback

- 1.) Move the **FUNCTION** selector to the **CD** position. The **POWER** indicator comes 'On'.
- 2.) Open the CD door by lifting the **OPEN** tab on the top panel. If you have not already removed the 'dummy' transit card from the CD player, please remove it now.
- 3.) Place your CD on the center spindle with the printed label side facing up. Close the CD door.

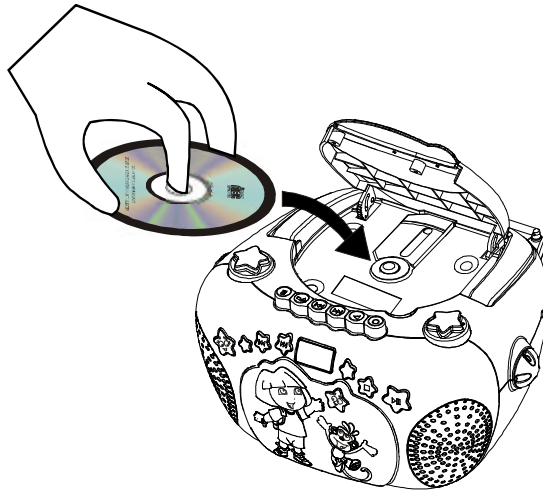

The player will read the Table of Contents and the display will show the total number of tracks on the disc.

If the disc is damaged or up side down, display shows "no".

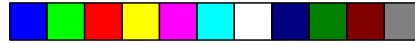

- 4.) Press the **PLAY/PAUSE ►II** button to begin playback on Track number “1”. The Play “dot” indicator appears in the display.



- To skip to higher or lower numbered tracks during playback press the **FWD ►►** or **REV ◄◄** button repeatedly until the desired track number appears in the display. Playback will begin on the selected track.
- To search rapidly forward or backward during playback to locate a specific portion of a track, depress and hold the **FWD ►►** or **REV ◄◄** button.

The player will search rapidly forward or backward as long as the buttons are depressed. Normal speed playback will resume when the buttons are released.

- To Pause momentarily during playback press the **PLAY/PAUSE ►II** button again.

The sound stops and the “Track number” flashes, however the disc continues to spin.



To cancel Pause and resume normal playback press the **PLAY/PAUSE ►II** button once more. Normal playback resumes and the “Track number” stops flashing.

- 5.) Adjust the **VOLUME** control as desired.
- 6.) To Stop playback at any time press the **STOP ■** button. The disc stops and the display again shows the total number of tracks on the disc.
- After the last track has played the disc stops automatically and the display again shows the total number of tracks on the disc.
- 7.) Open the CD door, remove your disc, and close the CD door again.
- 8.) Move the **FUNCTION** selector to the **OFF-TAPE** position to shut the power ‘Off’. The **POWER** indicator goes ‘Off’.

To Start Playback From A Specific Track

Insert your disc in the player, close the door, and wait until the display shows the total tracks.

Press either the **►►** or **◄◄** buttons until the desired track number appears in the display, then press the **►II** button to begin playback on that track.



Repeat Playback

You can program the player to repeat either a single track or all tracks on the disc continuously. The Repeat feature can be activated while the disc is playing or while the disc is stopped.

One Track Repeat

Press the **REPEAT** button once.

The Repeat “dot” indicator flashes.



Select the track you wish to repeat with the **▶▶** or **◀◀** buttons and then press the **▶||** button. The selected track will be repeated continuously.

All Tracks Repeat

Press the **REPEAT** button twice.

The Repeat “dot” indicator remains ‘On’.



Press the **▶||** button to begin playback. The entire disc will be repeated continuously.

To cancel Repeat playback, press the **REPEAT** button repeatedly until the Repeat “dot” Indicator goes ‘Off’.



Programmed Playback

You can program up to **20** tracks on a disc to playback in any desired order. You may also program a specific track to play several times within the same program.

Note: *The player cannot be programmed while a disc is playing. If a disc is playing press the **STOP** ■ button to stop playback before you begin the programming steps below.*

1.) Move the **FUNCTION** selector to **CD** position, insert your disc in the player, close the door, and wait until the total track number appears in the display.

2.) Press the **PROGRAM** button once.

The “01.” Indicator begins flashing in the display.

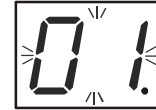

3.) Use the **FWD.** ►► or **REV.** ◄◄ buttons to select the first track to be programmed.

Example: Track “8”.



4.) Press the **PROGRAM** button once again to enter the track “8” in program memory number “01”.

Track number “8” disappears and the program number advances to flashing “02.”, indicating that you may now select a track to be entered in program memory number “02”.



5.) Use the ►► or ◄◄ buttons to select the next track to be programmed. When the desired track number appears in the display press the **PROGRAM** button again to enter that track in the program memory.

6.) Repeat Step 5 until you have entered up to 20 tracks in the program memory.

7.) To begin programmed playback press the **PLAY/PAUSE** ►|| button.

The LED display will show the first programmed track and playback will begin on that track. The “dot” Indicator flashes.



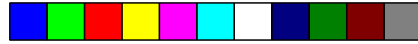

After the last programmed track has played the player stops but the programmed tracks remain in the memory.

The “dot” remains flashing.



To play the programmed tracks again, press the the **PLAY/PAUSE** ►|| button.

To cancel the programmed sequence from memory, press the **STOP** ■ button at Stop mode.

Program Repeat Playback

You can use the Program and Repeat features together to continuously repeat a programmed sequence of tracks.

First, program the desired tracks according to Steps 1 through 7 on page 15.

When Programmed Playback begins press the **REPEAT** button twice to activate the All Tracks Repeat feature.

The Repeat “dot” indicator appears in LED display and all the tracks in your programmed sequence will be repeated continuously.





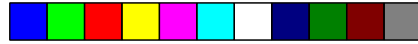



To cancel Programmed Repeat Playback press the **STOP** ■ button at Stop mode until both the “dot” indicators go ‘Off’.

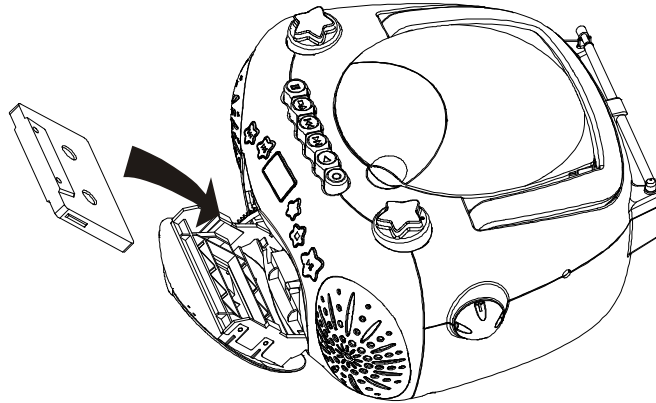

Playing Cassette Tapes

- 1.) Open the cassette door by pressing the **STOP/EJECT**  key.
- 2.) Place a pre-recorded cassette tape with the exposed tape facing up and the full reel on the right side.







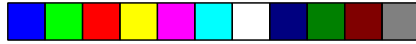

- 3.) Move the **FUNCTION** selector to the **OFF-TAPE** position.
- 4.) Press the cassette **PLAY**  key to begin playback.
- 5.) Set the **VOLUME** control as desired.
- 6.) To advance the tape rapidly press the **F. FWD**  key. To stop the tape before it ends press the **STOP/EJECT**  key.
- 7.) To rewind the tape rapidly press the **REWIND**  key. To stop the tape before it ends press the **STOP/EJECT**  key.
- 8.) When the tape ends the Automatic Stop System releases the **PLAY**  key and shuts off the tape motor. You may then open the cassette door, remove your tape, turn it over and play the other side if desired.
- 9.) When you are finished listening stop the tape, open the door, remove the tape and close the door.

If you are playing a tape and then switch to the **RADIO** or **CD** function be sure to press the **STOP/EJECT**  key to disengage the tape mechanism. This prevents excess wear and tear on the mechanism.







IMPORTANT:

Always press the **STOP/EJECT**  key to shut off the tape motor before opening the cassette door to remove your tape. The Automatic Stop System does not function in the **F.FWD**  and **REWIND**  modes. When the tape ends in the **F.FWD**  and **REWIND**  modes the motor continues to run. You must press the **STOP/EJECT**  key to shut off the motor before opening the door to remove your tape.

Making A Tape Recording

This model allows you to make tape recordings directly from the CD player, or the radio.

- Refer to “**Playing Compact Discs**” if necessary to operate the CD player.
- Refer to “**Listening To The Radio**” if necessary to tune in the station you wish to record from radio.

- 1.) Press the **STOP/EJECT**  key to open the cassette door.
- 2.) Insert a good quality blank cassette tape into the slots on the cassette door with the open end facing up and the full reel on the right. Use normal tape only. Do not use tape identified as “CrO₂” (Chrome) or “Metal” tape formulations. For best results use tapes of 60 minutes (C-60) or less. Do not use 90 minute or 120 minute tapes as these thinner tapes are more likely to jam in the mechanism.
- 3.) Close the cassette door.
- 4.) When you are ready to start recording press the **RECORD**  key. The **PLAY**  key will also engage. The CD you are playing, or radio program you selected will be recorded directly on to the tape.
- 5.) Press the **PAUSE**  key during recording to stop the tape temporarily and avoid recording unwanted material such as radio commercials.
- 6.) When you have finished recording press the **STOP/EJECT**  key to stop and remove the tape.



Automatic Recording Volume Level Control

This unit has an Automatic Level Control (ALC) circuit which controls the recording volume level and prevents overloaded and distorted recordings.

The **VOLUME** control has no effect on recording volume level. You may change the **VOLUME** control setting during the recording or even reduce the volume level to "Minimum". This will not effect the level of the recording.

Stereo Headphone Jack

Connect a set of stereo headphones (not included) with a 3.5mm mini plug to the **PHONES** jack (located at right side cabinet) for private listening without disturbing others.

Before putting on the headphones reduce the **VOLUME** control to a low level, then put the headphones on and gradually increase the **VOLUME** control to a comfortable listening level.

The built in speakers are automatically disconnected when headphones are connected to the **PHONES** jack.

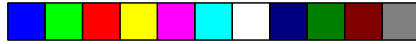

CARE AND MAINTENANCE

About Cassette Tapes

Whenever you record on a cassette any previously recorded material is erased as the new material is recorded. To prevent you from accidentally erasing material which you wish to save, blank cassettes are equipped with erase prevention tabs for each side of the tape. If the erase prevention tab for side A is removed, you cannot accidentally record on side A. The record key cannot be depressed if the erase prevention tab on the cassette has been removed.

To prevent accidental erasing on side A of a cassette use a small screw driver or similar tool to break off the erase prevention tab for side A. This prevents the record key from locking.

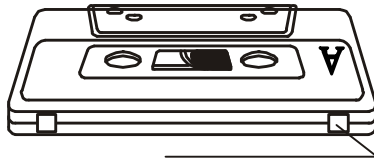

TAB FOR SIDE A
BREAK OUT TO PREVENT RECORDING

If later you do wish to record on side A of the cassette, cover the tab opening with a piece of cellophane tape. This will allow the record key to function again.

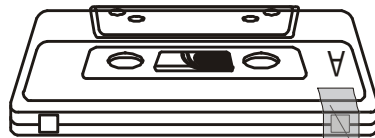

COVER OPENING WITH TAPE
IN ORDER TO RECORD AGAIN.

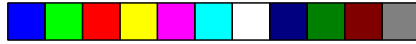

Cassette Care

Two common causes of trouble experienced when using cassettes are:

- 1.) Tape jamming — Leading to uneven speed in playback, and
- 2.) Tape tangling — Where the tape wraps itself around vital parts of the mechanism.

To reduce the likelihood of these problems occurring, the following precautions should be observed:

- Check that there are no loose layers of tape visible through the cassette center window (see Fig. 1). Take up any loose layers, using a pencil or hexagonal barrelled ballpoint pen, before inserting the cassette into the machine (see Fig. 2).
- If the cassette feels “tight” while performing operation shown (see Fig. 2), the tape may be jamming due to “ridges” formed in the winding of the tape (visible through the center window). These may be removed, in most cases, by fast winding of the cassette from one end to the other and back again.

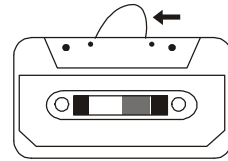

Fig. 1

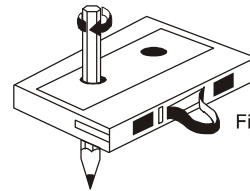
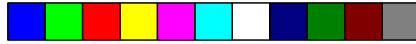

Fig. 2

- Use only well-known brands of tape. Avoid use of C-120 cassettes.

Furthermore, do not expose cassettes to direct sunlight, dust or oil, and do not touch the tape surfaces.



Head Cleaning

The tape heads, pinch roller and capstan require periodic cleaning. This removes particles of the metal oxide coating that wear off the tape and accumulate on these parts and impair performance.

Disconnect the AC power cord, press the **STOP/EJECT** ■▲ key to open the cassette door, and press the **PLAY** ◀ key. Clean the tape heads, pinch roller and capstan with a soft cloth or cotton pad dampened in isopropyl alcohol or special tape head cleaner.

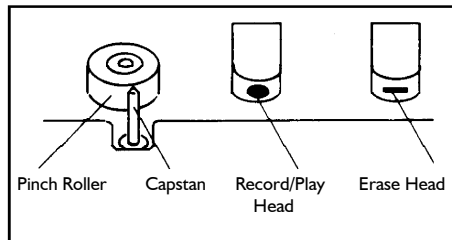

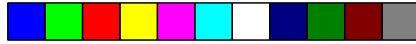

Compact Disc Care

- To remove a disc from its storage case, press down on the center of the case and lift the disc out, holding it carefully by the edges.

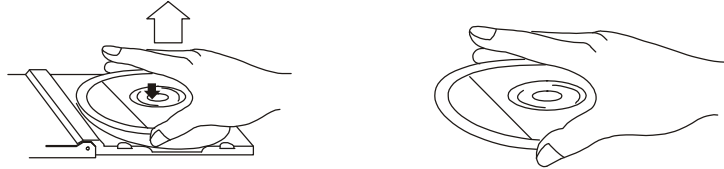

- Fingerprints and dust should be carefully wiped off the disc's recorded surface with a soft cloth. Unlike conventional records, compact discs have no grooves to collect dust and microscopic debris, so gently wiping with a soft cloth should remove most particles. Wipe in a straight line from the inside to the outside of the disc. Small dust particles and light stains will have absolutely no effect on reproduction quality.

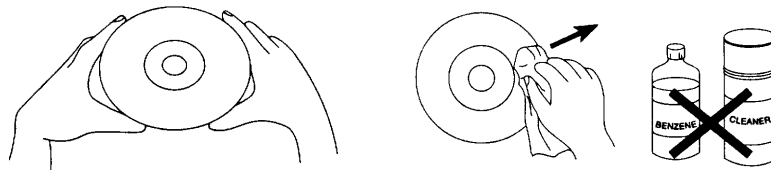

- Clean the disc periodically with a soft, lint-free, dry cloth. Never use detergents or abrasive cleaners to clean the disc. If necessary, use a CD cleaning kit.
- Never write on or affix labels to the surface of compact discs.

Care Of The Cabinet

If the cabinet becomes dusty wipe it with a soft dry dust cloth. Do not use any wax, polish sprays, or abrasive cleaners on the cabinet.

Caution

Never allow any water or other liquids to get inside the unit while cleaning.

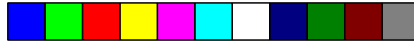

TROUBLESHOOTING GUIDE

Should this unit exhibit a problem, check the following before seeking service.

Symptom	Possible Cause	Solution
Radio		
Noise or sound distorted on AM or FM broadcasts.	Station not tuned properly for AM or FM.	Retune the AM, FM or FM ST. broadcast station.
	FM: Telescopic antenna is not extended.	Extend FM Telescopic antenna.
	AM: The bar antenna is not positioned correctly.	Reposition the unit until best reception is obtained.
FM STEREO indicator does not light.	The BAND selector is switched to FM position.	Switch the BAND selector to FM ST. position.
AM or FM, no sound.	FUNCTION switch is not set to RADIO.	Set FUNCTION switch to RADIO.
	Volume at minimum.	Increase Volume.
Compact Disc Player		
CD Player will not play.	FUNCTION switch is not set to CD.	Set FUNCTION switch to CD.
	CD is not installed or installed incorrectly.	Insert CD with label side up.
CD skips while playing.	Disc is dirty or scratched.	Wipe disc with cloth or use another disc.



Emerson[®]
SERVICE

TO FIND THE LOCATION AND PHONE NUMBER OF YOUR NEAREST SERVICE CENTER PERMITTED TO PERFORM WARRANTY...

CALL TOLL FREE: 1-800-695-0098

FOR ADDITIONAL SET-UP OR OPERATING ASSISTANCE
PLEASE CALL:
1-800-898-9020

FOR CUSTOMER SERVICE, PLEASE WRITE TO:
Emerson Radio Corp.
Consumer Affairs Dept.,
5101 Statesman Drive,
Irving, TX 75063.

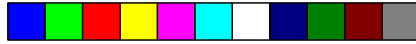

LIMITED WARRANTY

Emerson Radio Corp. warrants manufacturing defects in original material, including original parts and workmanship, under normal use and conditions, for a period of ninety (90) days from the date of original purchase in the U.S. With your dated proof of purchase, we will provide repair service at no charge for labor and parts at an authorized Depot Repair Facility, or replace the product in our discretion. For repair or replacement, pack your unit in a padded box, enclose your check or money order payable to Emerson Radio Corp. in the amount of \$9.00 (not required by California residents) to cover shipping and handling costs, and enclose a copy of your proof of purchase. Send your unit to:

Emerson Radio Corp.,
5101 Statesman Drive,
Irving, TX 75063.

This warranty does not cover damage from negligence, misuse, abuse, accident, failure to follow operating instructions, commercial use, rental, repairs by an unauthorized facility, or products purchased, used, serviced or damaged outside of the United States.

THIS WARRANTY GIVES YOU SPECIFIC LEGAL RIGHTS, AND YOU MAY ALSO HAVE OTHER RIGHTS WHICH VARY FROM STATE TO STATE.

AU898M

The serial number can be found on the back cabinet. We suggest that you record the serial number of your unit in the space below for future reference.

Model Number: DTE288

Serial Number: _____





EMERSON
Part No. 21-2084
508-01

Printed in China