



COMPACT REFRIGERATOR

OWNER'S MANUAL **ER103002**

[http:// www.emersonradio.com](http://www.emersonradio.com)

UNAUTHORIZED MODIFICATIONS TO THIS DEVICE COULD VOID MANUFACTURER'S WARRANTY.

THIS PAGE INTENTIONALLY LEFT BLANK

IMPORTANT SAFETY INSTRUCTION

Please follow the precautions below for your new refrigerator:

1. This refrigerator must be properly installed and located in accordance with the Installation Instructions before it is used.
2. Do not allow children to climb, stand or hang on the shelves in the refrigerator. They could damage the refrigerator and seriously injure themselves.
3. Do not store or use gasoline or other flammable vapors and liquids in the vicinity of this or any other appliance.
4. Keep fingers out of the clearances between the doors and cabinet. Be careful closing doors when children are in the area.
5. Unplug the refrigerator before cleaning and making repairs.
6. We strongly recommend that any servicing be performed by a qualified individual.
7. Turning the temperature control dial to the 0 position stops cooling but does not shut off power to the refrigerator.
8. Do not leave refrigerator in extreme cold or warm temperatures.
9. Do not place refrigerator near heat sources or open flames.
10. Clean the refrigerator with a soft, damp cloth. Remove stains with a mild soap. Do not clean the unit with industrial grade solvents, or abrasive chemicals.
11. Do not place heavy items on top of the refrigerator.
12. Never install the refrigerator where there is a lot of moisture and water can splash.
13. Do not allow children to hang on the doors; the refrigerator may be tipped over and hurt children.
14. Never eat spoiled food stored too long in the refrigerator or in an out-of-order refrigerator.
15. Do not use sharp tools inside the refrigerator - for example - to remove ice as damage may occur.
16. Unplug and remove food from the refrigerator if not used for a long period of time.
17. Caution: flammable refrigerant used! When handling, moving and use of the refrigerator, make sure to avoid either damaging the refrigerant tubing, or increasing the risk of a leak.
18. The refrigerant isobutene (R600a) is contained within the refrigerant circuit of the appliance, a natural gas with a high level of environmental compatibility, which is nevertheless flammable. During transportation and installation of the appliance, ensure that none of the components of the refrigerant circuit becomes damaged. The refrigerant (R600a) is flammable.

PROPER DISPOSAL

An empty refrigerator is an extremely dangerous attraction to children. If you are getting rid of your old refrigerator. Please follow the instructions in the Child Entrapment Warning.

CHILD ENTRAPMENT WARNING:

Risk of child entrapment. Before you throw away your old refrigerator or freezer:

1. Take off the doors.
2. Leave the shelves in place so that children may not easily climb inside.

CAUTIONS: USE OF AN EXTENSION CORD IS NOT RECOMMENDED.

FOR HOUSEHOLD USE ONLY
SAVE THESE INSTRUCTIONS

GROUNDING INSTRUCTIONS

This appliance must be grounded. In the event of an electrical short circuit, grounding reduces the risk of electric shock by providing an escape wire for the electric current. This appliance is equipped with a cord having a grounding wire with a grounding plug. The plug must be inserted into an outlet that is properly installed and grounded.

WARNING: Improper use of the grounding plug can result in a risk of electric shock. Consult a qualified electrician or service person if the grounding instructions are not completely understood, or if doubt exists as to whether the appliance is properly grounded. If it is necessary to use an extension cord, use only a three wire extension cord that has a three blade grounding plug, and a three slot receptacle that will accept the plug on the appliance. The marked rating of the extension cord should be equal to or greater than the electrical rating of the appliance.

INSTALLATION

1. Steady, flat location:

If the refrigerator is not leveled during installation, the doors may not close or seal properly, causing cooling, frost, or moisture problems. It is very important for the refrigerator to be level in order to function properly.

To level your refrigerator, you may either turn the level leg clockwise to raise that side to the refrigerator or turn counter-clockwise to lower that side. Having someone push against the top of the refrigerator, it will take some weight off the leveling leg. This makes it easier to adjust the leveling leg.

2. Ventilation:

Place refrigerator approximately 5 inches from the wall to ensure proper airflow to the compressor. Do not place refrigerator near any heat resources such as a heater or stove as it will put a strain on the compressor.

3. Power supply:

- Check your local power source. This refrigerator requires a 110V - 120V, 60Hz power supply.

- Use a receptacle that will accept the ground prong. The power cord of this appliance is equipped with a 3-prong (grounding) plug which mates with a standard 3-prong (grounding) wall outlet to minimize the possibility of electric shock hazard from this appliance.

A. Longer cord sets or extension cords are available and may be used if care is exercised in their use.

B. If a long cord or extension cord is used, (1) the marked electrical rating of the cord set or extension cord should be at least as great as the electrical rating of the appliance, (2) the extension cord must be a grounding-type 3-wire cord, and (3) the longer cord should be arranged so that it will not drape over the counter top or table top where it can be pulled on by children or tripped over unintentionally.

NOTES:

The refrigerator should always be plugged into its own individual electrical outlet which has a voltage rating that matches the rating plate.

If you have only a standard 2-prong wall outlet, it is your personal responsibility and obligation to have it replaced with a properly grounded 3-prong wall outlet.

Never unplug your refrigerator by pulling on the power cord. Always grip plug firmly and pull straight out from the outlet.

When using a 3 pronged plug

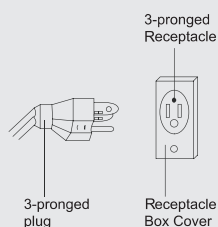

When using a grounding adapter, make sure the receptacle box is fully grounded.

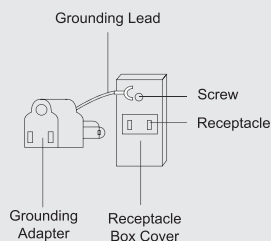

LOCATION OF CONTROLS

DOOR CLOSED

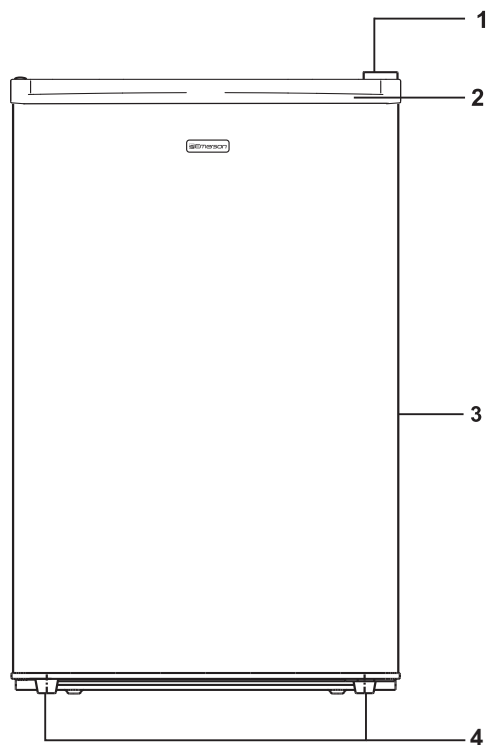

1. Top Hinge
2. The Handle
3. Refrigerator Door
4. Leveling Feet

LOCATION OF CONTROLS (CONTINUED)

DOOR OPEN

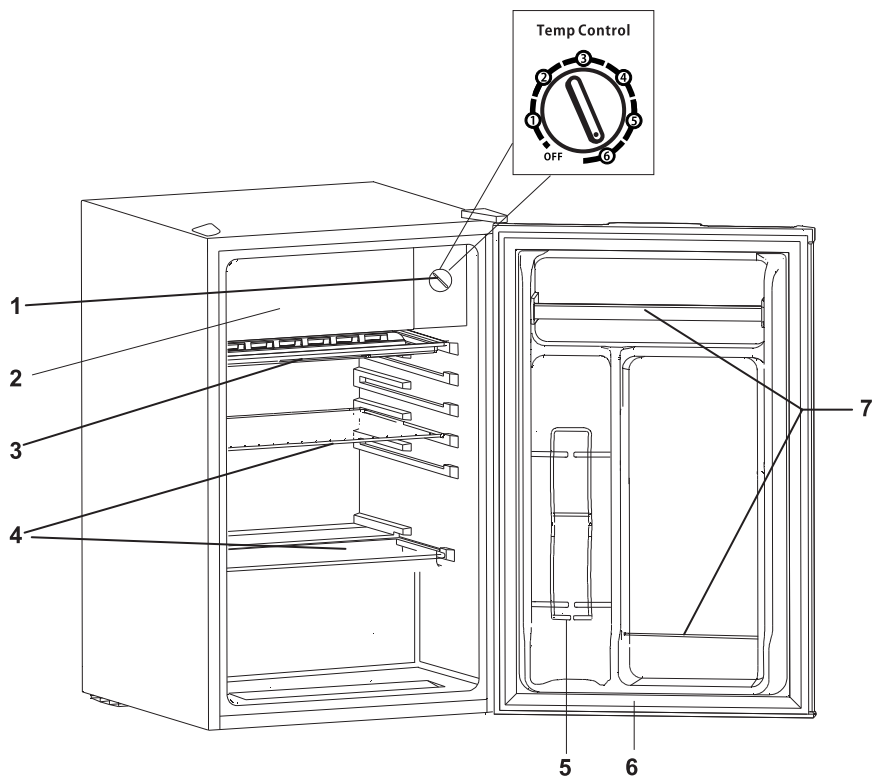

1. Thermostat Control Knob
2. Chiller Compartment
3. Drip Tray
4. Shelf
5. Bottle Storage
6. Door Gasket
7. Soda Can Storage

OPERATION

NOTES: Temperature range of the chiller compartment is 30°F to 48°F at room temperature of 77°F (25°C). Ice cream and Popsicles must be kept cool at -5°F to 0°F, hence this chiller compartment is not suitable to store these types of items.

USING THE THERMOSTAT

Thermostat control dial

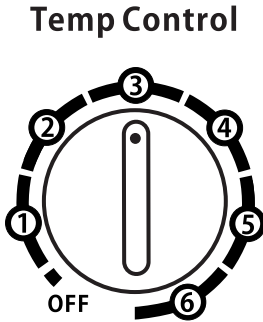

Temp Control

chiller is located at the upper right hand corner of the chiller compartment.

The first time you turn the unit on, adjust the thermostat control knob to 3 and give your refrigerator time to cool down completely before adding food; a full 24 hours is recommended.

After it is fully cooled, test it and adjust towards 1 to make less cool or towards 6 to cool more to best suit your needs. However, the setting of 3 should be appropriate for home or office refrigerator use.

NOTE: Turning the thermostat control knob to the "OFF" position will stop the cooling cycle but does not shut off the power to the unit.

DEFROSTING

Thermostat control dial

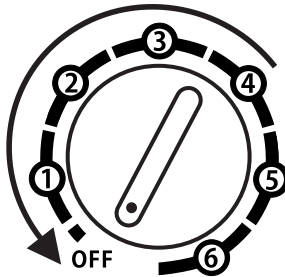

Temp Control

Defrosting process is manual:

1. Turn the thermostat knob to the "OFF" position and leave the refrigerator door open.
2. Remove all food from the chiller and refrigerator compartment.
3. Clean and wipe out the melted frost with a cloth.
4. After defrosting, turn thermostat knob to original position.

NOTE: If the chiller has accumulated excessive frost/ice, please do the following:

1. Remove all food from the chiller and refrigerator compartment.
2. Turn the thermostat knob to the "OFF" position and unplug from the outlet.
3. Place towel under compact refrigerator or move refrigerator outdoors where no water damage can occur.
4. Follow steps 3 & 4 from above section.

OPERATION (CONTINUED)

REVERSING THE DOOR POSITION

CAUTION:

To avoid injury to yourself and/or property, we recommend someone assist you during the door reversal process.

- Ensure the Appliance is unplugged and empty.
- Adjust the two leveling feet to their highest position.
- We recommend you have someone to assist you.

TOOLS REQUIRED

- 8mm socket screw driver
- Phillips style screw driver

1. Upper Hinge Bracket

2. Adjustable Leveling Foot

3. Machine Screw



NOTE:

To take the door off it is necessary to tilt the Appliance backward. You should rest the Appliance on something solid, e.g. a chair just below the top panel.

DO NOT lay the Appliance completely flat as this may damage the coolant system.

4. Bottom Hinge Bracket



5. Level Foot



1

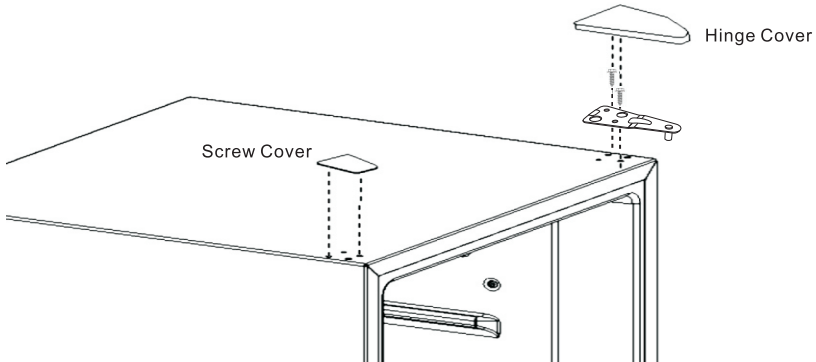

Remove the upper hinge cover, then unscrew the upper screws of metal hinge bracket and take off the hinge. Then take off the left side screw cover. Pull the appliance door upward to take it off.

2

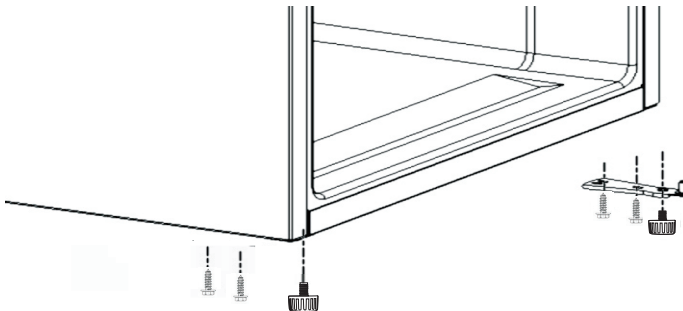

Remove left leveling foot and the bottom hinge bracket by unscrewing the mounting screws. At the same time, remove the mounting screws next to left leveling foot.

OPERATION (CONTINUED)

3

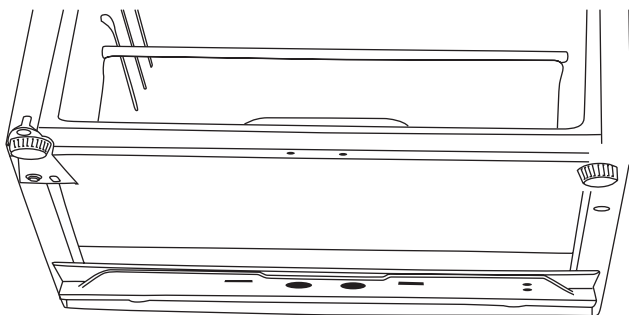

BOTTOM VIEW

Install the leveling foot and the bottom hinge bracket on the new bottom side. Then tighten the screws of the bottom hinge bracket.

4

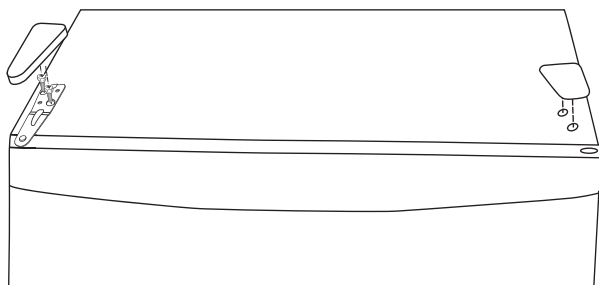

Slot in the appliance door into the bottom hinge pin. Replace the upper hinge bracket on the new side and check the fitting between the door/ hinge moving smoothly. Then tighten the screws of upper hinge bracket. Replace the hinge cover and the right side screw cover.

5

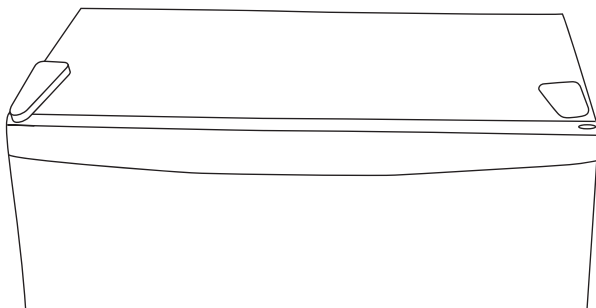

Check that the door is aligned horizontally and vertically and that the seals are closed on all sides before finally tightening the upper hinge. Re-adjust the leveling feet.

TROUBLE SHOOTING GUIDE

The refrigerator will not operate

- The power supply cord is unplugged.
- The thermostat knob is set to the OFF position.
- A household fuse or circuit breaker has tripped.

Food in the refrigerator compartment is freezing

- The thermostat knob is set too cold.

Food in the refrigerator compartment is not cold

- The air vents on the drip tray are blocked in the compartment; this prevents the movement of cold air.
- The door is opened too often or not closed properly.
- A large amount of food has just been added to the refrigerator or chiller compartment.
- The position of thermostat knob is adjusted too low.

The refrigerator seems to make unusual noise

- The refrigerator is not leveled on the floor.
- The body of the refrigerator touches a wall.
- The drip tray is not placed properly.

There is interior moisture build-up

- The door is opened too often or not closed properly.
- The room is humid.
- The food is not packaged correctly.

The door will not close completely

- Food packages are keeping the door from closing properly.
- The shelves are out of position
- The gaskets are dirty.
- The refrigerator is not level.

TECHNICAL SPECIFICATION

Unit Dimension (WxDxH) (inches)	17.3 x 20.2 x 27.0
Power Supply	AC115V 60Hz 84W
Current	0.8A
Power consumption per year	214 kwh

LIMITED WARRANTY

Emerson Radio Corp. warrants this product to be free from manufacturing defects in original material, including original parts, and workmanship under normal home use and conditions ("manufacturing defect") for a period of one (1) year from date of original purchase in, and if used in the United States. Should service be necessary under this warranty, Emerson will provide the following at our Return Repair Facility provided the manufacturing defect is verified along with the date of purchase:

* Repair service for one (1) year from date of original purchase at no charge for labor and parts.

To Receive Authorization to Return a Defective Item, please contact Emerson Customer Service at 1-800-898-9020. Have your Model number, Serial Number and dated Proof of Purchase with you when you call.

In the event the product must be returned to Emerson:

- * Pack the unit in a well-padded heavy corrugated box. Please insure the item is well padded to avoid damage while in transit back to our facility. If the item incurs damage, it will NOT be replaced and the consumer will be responsible for return freight costs to receive their same unit back.
- * Enclose your check or money order payable to Emerson Radio in the amount of \$15 to cover return shipping and handling costs.
- * Enclose a note with your name, address, phone number, Return Authorization number and brief reason for returning the unit.
- * Enclose a copy of your proof of purchase (warranty service will not be provided without dated proof of purchase).
- * Ship the unit prepaid via UPS or parcel post (SHIP INSURED and obtain a tracking number).

NOTE: This warranty does not cover:

- (a) Damage to equipment not properly connected to the product.
- (b) Cost incurred in the shipping of the product to and from Emerson's Return Facility.
- (c) Damage or improper operation of unit caused by customer abuse, misuse, negligence or failure to follow operating instructions (including cleaning instructions) provided with the product.
- (d) Ordinary adjustments to the product which can be performed by customer as outlined in the owner's manual.
- (e) Products not purchased in the United States.
- (f) Damage to product if used outside the United States.

THIS WARRANTY IS NON-TRANSFERABLE AND APPLIES ONLY TO THE ORIGINAL PURCHASER AND DOES NOT EXTEND TO SUBSEQUENT OWNERS OF THE PRODUCT. ANY APPLICABLE IMPLIED WARRANTIES, INCLUDING THE WARRANTY OF MERCHANTABILITY, ARE LIMITED IN DURATION TO A PERIOD OF THE EXPRESSED WARRANTY AS PROVIDED HEREIN BEGINNING WITH THE DATE OF ORIGINAL PURCHASE AT RETAIL AND NO WARRANTIES, WHETHER EXPRESSED OR IMPLIED, SHALL APPLY TO THE PRODUCT THEREAFTER. EMERSON MAKES NO WARRANTY AS TO THE FITNESS OF THE PRODUCT FOR ANY PARTICULAR PURPOSE OR USE.

THE EXTENT OF EMERSON RADIO CORP'S LIABILITY UNDER THIS LIMITED WARRANTY IS THE REPAIR OR REPLACEMENT PROVIDED ABOVE AND, IN NO EVENT, SHALL EMERSON RADIO CORP'S LIABILITY EXCEED THE PURCHASE PRICE PAID BY THE PURCHASER OF THE PRODUCT. UNDER NO CIRCUMSTANCES SHALL EMERSON RADIO CORP. BE LIABLE FOR ANY LOSS, DIRECT, INDIRECT, INCIDENTAL, SPECIAL, OR CONSEQUENTIAL DAMAGE ARISING OUT OF OR IN CONNECTION WITH THE USE OF THIS PRODUCT. THIS WARRANTY IS VALID ONLY IN THE UNITED STATES OF AMERICA.

THIS WARRANTY GIVES YOU SPECIFIC LEGAL RIGHTS. HOWEVER, YOU MAY HAVE OTHER RIGHTS WHICH MAY VARY FROM STATE TO STATE. SOME STATES DO NOT ALLOW LIMITATIONS ON IMPLIED WARRANTIES OR EXCLUSION OF CONSEQUENTIAL DAMAGE, THEREFORE THESE RESTRICTIONS MAY NOT APPLY TO YOU.

15-01-1402

The serial number can be found on the back cabinet. We suggest that you record the serial number of your unit in the space below for future reference.

Model Number: ER103002

Serial Number: _____



***** SERVICE *****

FOR ADDITIONAL SET-UP OR OPERATING ASSISTANCE

PLEASE CALL:

1-800-898-9020

FOR CUSTOMER SERVICE, PLEASE E-MAIL TO:

internet@emersonradio.com

OR WRITE TO:

Emerson Radio Corp.

Consumer Affairs Dept.

3 University Plaza

Suite 405

Hackensack, NJ 07601



EMERSON

PART NO.: ER103002-20170623-0

Printed in China

4071099