

# EnGenius®



WIRELESS 11N LONG RANGE OUTDOOR AP / CB  
ENS500EXT User Guide

V1.0

# TABLE OF CONTENTS

## Product Overview

Package Contents	1-1
Product Overview	1-2
Hardware Features . . . . .	1-2
Software Features . . . . .	1-2
Benefits . . . . .	1-3
Technical Specification . . . . .	1-4
Hardware Specification . . . . .	1-4
Software Specification . . . . .	1-4
Environment & Mechanical . . . . .	1-4
Wireless Specification . . . . .	1-5
Product Layout	1-6

## Installation

System Requirements	2-1
Installing the Device	2-2
Pre-Installation Guidelines . . . . .	2-2
Installing the Device . . . . .	2-2

## Web Configuration

Logging In	3-1
Best Practices . . . . .	3-2

## Basic Network Settings

System Status	4-1
Using Save/Reload	4-1
Viewing System Information	4-2
Viewing Wireless Client List	4-4
Viewing System Log	4-5
Viewing Connection Status	4-6
Viewing DHCP Client Table	4-7
Viewing WDS Link List	4-8

System Setup	4-9
Configuring Operation Mode	4-9
Configuring IP Settings	4-10
Configuring Spanning Tree Settings	4-11
Router Setup	4-12
Configuring WAN Settings	4-12
Static IP . . . . .	4-12
Dynamic IP . . . . .	4-13
Point-to-Point Protocol over Ethernet (PPPoE) . . . . .	4-14
Point-to-Point Tunnelling Protocol (PPTP) . . . . .	4-15
Configuring LAN Settings	4-17
Configuring VPN Pass-Through	4-18
Configuring Port Forwarding	4-19
Configuring Demilitarized Zone	4-21
Configuring Wireless LAN	4-22
Configuring Wireless Settings	4-22
Access Point Mode . . . . .	4-22
Client Bridge Mode . . . . .	4-24
WDS Bridge Mode . . . . .	4-25
Client Router Mode . . . . .	4-27

Configuring Wireless Security	4-28
Wired Equivalent Privacy (WEP) . . . . .	4-28
Wi-Fi Protected Access Pre-Shared Key (WPA-PSK) . . . . .	4-29
Wi-Fi Protected Access 2 Pre-Shared Key (WPA2-PSK) . . . . .	4-30
Wi-Fi Protected Access Pre-Shared Key (WPA-PSK) Mixed . . . . .	4-31
Wi-Fi Protected Access (WPA) . . . . .	4-32
Wi-Fi Protected Access 2 (WPA2) . . . . .	4-33
Wi-Fi Protected Access (WPA) Mixed . . . . .	4-34
Configuring Wireless MAC Filter	4-35
Configuring WDS Link Settings	4-36
Configuring Wireless Advanced Settings	4-37
Management Setup	4-39
Configuring Administrator Account	4-39
Configuring Management VLAN	4-40
Configuring SNMP	4-41
Configuring Backup/Restore Settings	4-43
Configuring Firmware Upgrade	4-44
Configuring System Time	4-45
Configuring Wi-Fi Schedule	4-46
Add a Schedule Service . . . . .	4-46
Schedule Services Table. . . . .	4-47

Configuring Command Line Interface	4-48
Configuring Logging	4-49
Configuring Diagnostics	4-50
Viewing Device Discovery	4-51
Configure Denial of Service Protection	4-52
Logging Out	4-53

## Appendix A

Federal Communication Commission Interference Statement	A-1
---	-----

## Appendix B

Industry Canada Statement	B-1
---------------------------	-----

## Appendix C

WorldWide Technical Support	C-1
-----------------------------	-----

# Conventions

The following conventions are used to give the user additional information about specific procedures or content. It is important to pay attention to these conventions as they provide information to prevent damage to equipment or personal injury.

## General Conventions

The following general conventions are used in this document.



### **CAUTION!**

CAUTIONS APPEAR BEFORE THE TEXT IT REFERENCES. CAUTIONS APPEAR IN CAPITAL LETTERS TO EMPHASIZE THAT THE MESSAGE CONTAINS VITAL HEALTH AND SAFETY INFORMATION.



### **WARNING!**

Warning information appears before the text it references to emphasize that the content may prevent damage to the device or equipment.



### **Important:**

Indicates information that is important to know for the proper completion of a procedure, choice of an option, or completing a task.



### **Note:**

Indicates additional information that is relevant to the current process or procedure.



### **Example:**

Indicates information used to demonstrate or explain an associated concept.

### **N/A:**

Indicates that a component or a procedure is not applicable to this model.

### **Prerequisite:**

Indicates a requirement that must be addressed before proceeding with the current function or procedure.

## Typographical Conventions

The following typographical conventions are used in this document:

### *Italics*

Indicates book titles, directory names, file names, path names, and program/process names.

### Constant width

Indicates computer output shown on a computer screen, including menus, prompts, responses to input, and error messages.

### **Constant width bold**

Indicates commands lines as entered on the computer. Variables contained within user input are shown in angle brackets (< >).

### **Bold**

Indicates keyboard keys that are pressed by the user.



# Copyright

This user guide and its content is copyright of © EnGenius Networks, 2012. All rights reserved.

Any redistribution or reproduction in part or in whole in any form is prohibited.

Do not distribute, transmit, store in any form of electronic retrieval system or commercially exploit the content without the expressed written permission of EnGenius Networks.

# Product Overview

Chapter 1

# 1.1 Package Contents

- ENS500EXT
- Quick Start Guide
- Technical Support Card
- Pole Mounting Strap x2
- Wall Mounting Screw Set
- PoE Injector (EPE1212) with Power Adapter
- Two detachable 5 dBi high gain omni-directional antennas

## 1.2 Product Overview

The ENS500EXT Wireless Outdoor unit provides not only detachable antenna connectors for antenna upgrade, but also high output power and high sensitivity can extend the transmission range to deliver a stable wireless connection. ENS500EXT integrates 4 operation modes: Access Point, Client Bridge, Client Router and WDS.

Advanced multi-function operation modes offer flexibility in constructing scalable wireless networks for all possible applications. ENS500EXT is designed to deliver reliable service under harsh outdoor environment with certified IP65 protection and tailored to accommodate multimedia streaming services with data-rate up to 300Mbps. Most importantly, it is built-in encryption standards (WEP, WPA, WPA2, TKIP/AES and IEEE802.1x) ensure maximum security and compatibility.

### Hardware Features

- **High output power:** Transmit high output power for great coverage
- **High Data Rate:** High speed transmitting rate up to 300Mbps with 2T2R 802.11n
- **Long range transmitting:** Transmit power control and distance control (ACK timeout)
- **Signal Strength Display:** Indicate RF signal strength to be shown as LEDs of 3 colors, making network build-up

easier. LED indicators have the best transmit and receive signal for traffic communication

- **PoE Support:** Support proprietary 24V passive power over Ethernet

### Software Features

- **Multiple SSID:** 4 SSID supported. Each SSID can set itself wireless or WAN access setting
- **PPPoE:** Point-to-Point Protocol over Ethernet at Client Router mode. This function will keep trying when failed or disconnected
- **PPTP:** Point-to-Point Tunneling Protocol (PPTP) is a method for implementing virtual private networks
- **VLAN Pass-through:** Support VLAN Pass-through
- **Firmware Upgrade:** Upgrading firmware via web browser, setting are reserved after upgrade
- **Reset & Backup:** Reset to factory default. User can export all setting into a file via WEB
- **Ping & Trace Route:** Built-in PING function & Trace Route function in Web GUI
- **MIB:** MIB I, MIB II(RFC1213), Private MIB
- **SNMP:** V1, V2c, V3

## Benefits

The ENS500EXT is the ideal product around which you can build your WLAN. The following list summarizes a few key advantages that WLANs have over wired networks:

### **Ideal for hard-to-wire environments**

There are many scenarios where cables cannot be used to connect networking devices. Historic and older buildings, open areas, and busy streets, for example, make wired LAN installations difficult, expensive, or impossible.

### **Temporary workgroups**

WLANs make it easy to provide connectivity to temporary workgroups that will later be removed. Examples include parks, athletic arenas, exhibition centers, disaster-recovery shelters, temporary offices, and construction sites.

### **Ability to access real-time information**

With a WLAN, workers who rely on access to real-time information, such as doctors and nurses, point-of-sale employees, mobile workers, and warehouse personnel, can access the data they need and increase productivity, without having to look for a place to plug into the network.

### **Frequently changed environments**

WLANs are well suited for showrooms, meeting rooms, retail stores, and manufacturing sites where workplaces are rearranged frequently.

### **Wireless extensions to Ethernet networks**

WLANs enable network managers in dynamic environments to minimize overhead caused by moves, extensions to networks, and other changes.

### **Wired LAN backup**

Network managers can implement WLANs to provide backup for mission-critical applications running on wired networks.

### **Mobility within training/educational facilities**

Training sites at corporations and students at universities are a few examples where wireless connectivity can be used to facilitate access to information, information exchanges, and learning.

# Technical Specification

## Hardware Specification

- **Physical Interface:**
  - 2 x RJ-45 for 10/100 Fast Ethernet; one port is compatible with PoE
  - 1 x Reset Button
- **Power Requirements:**
  - Active Ethernet (Power over Ethernet)
  - Proprietary PoE design
  - Power Adapter 24V / 0.6A

## Software Specification

- **Operation Mode:** Client Bridge, Access Point, Client Router, WDS AP, WDS Bridge, WDS Station
- **Wireless/Network:**
  - Auto Channel Selection (Setting varies by Regular Domains)
  - Obey Regulatory Power
  - Distance Control (802.1x ACK (acknowledgement) timeout)
  - CLI Supported
  - 802.1x Supplicant (CB Mode)
  - 4 SSIDs

- WDS AP / WDS Bridge / WDS Station
- Multicast Supported
- RADIUS Accounting
- VLAN Tag / VLAN Pass-through
- Auto Reboot
- WiFi Scheduling
- **Security:**
  - WEP Encryption-64/128/152 bit
  - WPA/WPA2 Personal (WPA-PSK using TKIP or AES)
  - WPA/WPA2 Enterprise (WPA-EAP using TKIP)
  - Hide SSID in beacons
  - MAC address filtering, up to 50 field
  - Wireless STA (Client) connected list
- **QoS:** WMM

## Environment & Mechanical

- **Temperature Range:**
  - Operating -20°C~70°C
  - Storage -30°C to 80°C
- **Humidity (non-condensing):** 0%~90% typical
- **Dimensions**

- **with antenna:** 100mm (4") x 37.5mm (1.375") x 205mm (8") (W x D x H)
- **without antenna:** 100mm (4") x 37.5mm (1.37") x 189mm (7.375") (W x D x H)
- **Weight**
  - **with antenna:** 242g (0.11 lbs) ± 2g
  - **without antenna:** 275g (0.125lbs) ±2g

## Wireless Specification

- **Frequency Band:** 802.11a/n
- **Data rate:** 300 Mbps
- **Antenna:** 2 x Detachable SMA Connector



### Note:

The maximum power of the radio frequency band may be different depending on local regulations.

# 1.3 Product Layout

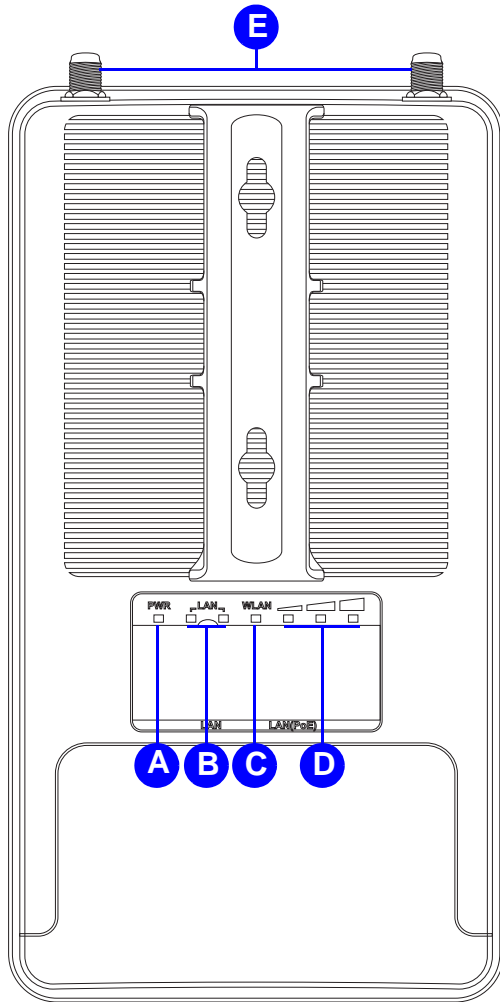
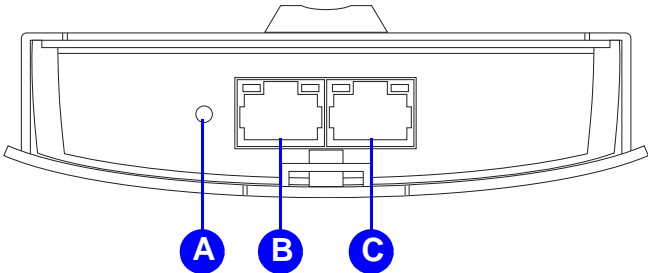

Figure 1-1: Back Panel View

BACK PANEL VIEW		DESCRIPTION
A	Power LED	OFF = ENS500EXT is not receiving power ON = ENS500EXT is receiving power
B	LAN (2) LEDs	OFF = ENS500EXT is not connected to the network. ON = ENS500EXT is connected to the network, but not sending or receiving data Blink = ENS500EXT is sending or receiving data
C	WLAN LED	(Access Point or Client Bridge Mode) OFF = ENS500EXT radio is off and the device is not sending or receiving data over the wireless LAN. ON = ENS500EXT radio is on, and the device is not sending or receiving data over the wireless LAN. Blinking = ENS500EXT radio is on, and the device is sending or receiving data over the wireless LAN.
D	Signal Indicator LED	(Client Bridge or WDS Station Mode) Green - Signal is good Orange - Signal is normal Red - Signal is weak or non-existent
E	Antenna Connectors	





BOTTOM VIEW		DESCRIPTION
A	Reset Button	To reset to factory settings, press button for > 10 seconds.
B	LAN Connector	To configure the ENS500EXT, connect an Ethernet cable to an Ethernet adapter on a computer. For more information about configuring individual features, see <i>Logging In</i> .
C	PoE LAN Connector	The PoE interface allows the ENS500EXT to be powered using the supplied PoE injector

# Installation

Chapter 2

## 2.1 System Requirements

To install the ENS500EXT, you need the following:

- Computer (Windows, Linux, Mac OS X Operating System)
- Web Browser (Internet Explorer, FireFox, Chrome, Safari)
- Network Interface equipped: (one of the following)
  - **Wired connectivity:** Network Interface with an open RJ-45 Ethernet Port
  - **Wireless Connectivity:**
    - Embedded 802.11n Wi-Fi wireless networking, IEEE 802.11a/b/g compatible
    - Wi-Fi Card, USB Wi-Fi Dongle (802.11 a/n)
- An existing router or access point (AP) with SSID broadcast
- 1x CAT5e Ethernet Cable

**Note:**

The minimum requirement for Ethernet cable power supply usage is CAT5e.

## 2.2 Installing the Device

Installing the ENS500EXT on a pole or wall optimizes the wireless access range.

**Note:**

Only experienced installation professionals who are familiar with local building and safety codes and, wherever applicable, are licensed by the appropriate government regulatory authorities should install the ENS500EXT.

### Pre-Installation Guidelines

Select the optimal location for the equipment using the following guidelines:

- The ENS500EXT should be mounted on a pole 1" to 4" (2.54cm to 10.16cm) in diameter. Its location should enable easy access to the unit and its connectors for installation and testing.
- The higher the placement of the antenna, the better the achievable link quality.
- The antenna should be installed to provide a direct, or near line of sight with the Base Station antenna. The antenna should be aligned to face the general direction of the Base Station.

### Installing the Device

To install the ENS500EXT, use the following procedure to mount the device on a pole and refer to the figure below.

1. Remove the bottom cover protecting the RJ-45 connectors.

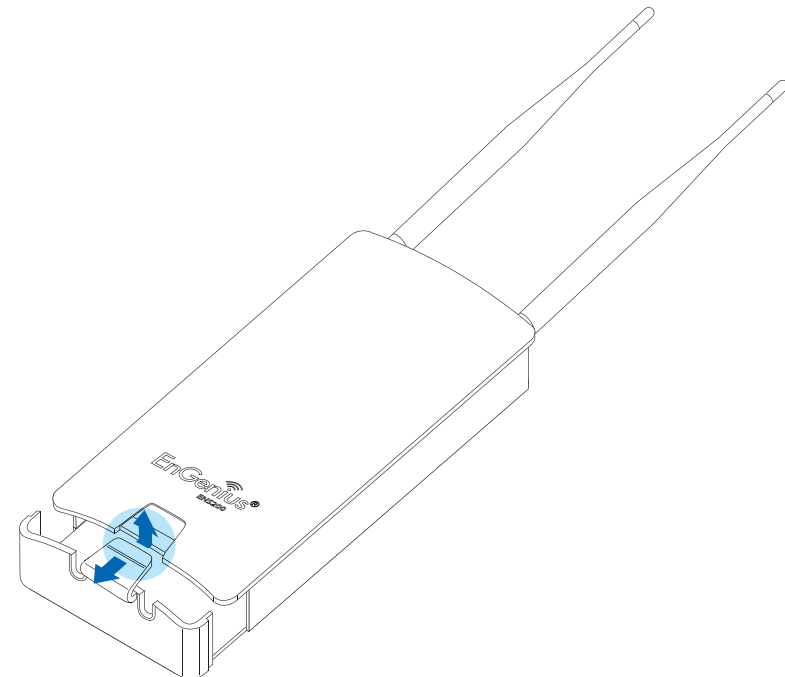

**Figure 2-1: Removing the RJ-45 Port Cover**

2. Insert an Ethernet cable into the RJ-45 port labeled LAN (PoE) on the ENS500EXT.
3. Plug the other end of the Ethernet cable into the PoE port of the PoE injector.
4. Remove the power cord and PoE injector from the box and plug the power cord into the DC port of the PoE injector.

**CAUTION!**

ONLY USE THE POWER ADAPTER SUPPLIED WITH THE ENS500EXT. USING A DIFFERENT POWER ADAPTER MIGHT DAMAGE THE ENS500EXT.

5. Plug another Ethernet cable into the LAN port of the PoE injector and connect the other end of Ethernet cable to the LAN port of the PC.

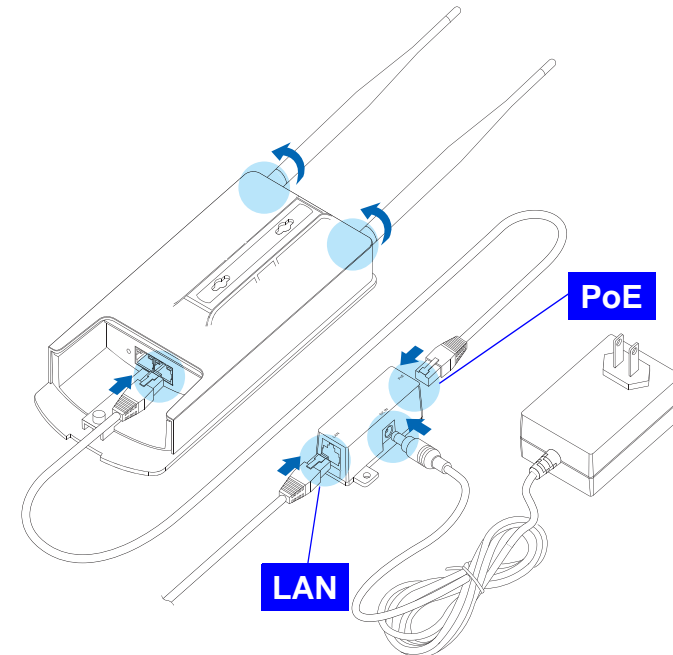

**Figure 2-2: Installing the ENS500EXT**

6. Attach and secure the two antennas to the top of the ENS500EXT.

7. Install the bottom cover securely to protect the RJ-45 connectors.

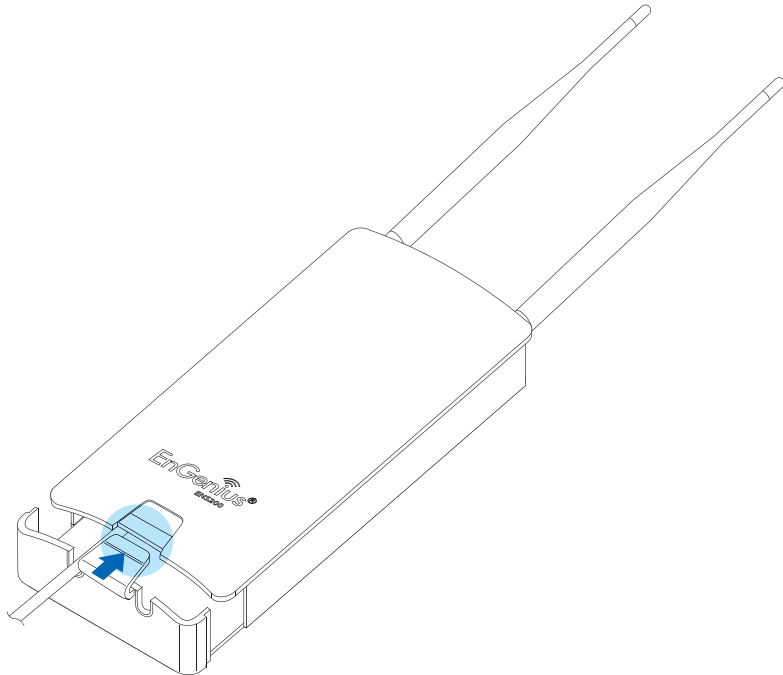

**Figure 2-3: Installing the RJ-45 Port Cover**

8. Turn over the ENS500EXT.

To mount the ENS500EXT on a wall or a pole, follow these steps:



**Note:**

Find a position for the ENS500EXT that provides the best signal.

**Wall mount:**

1. Secure the adhesive label to a position on the wall where you would like to install the ENS500EXT.

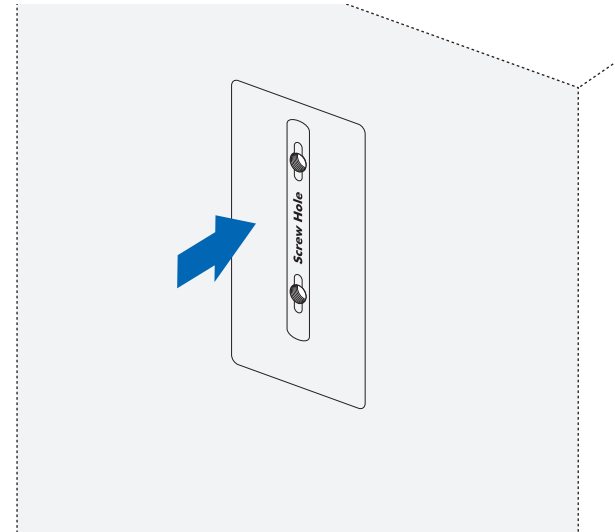

**Figure 2-4: Screw Layout Adhesive Label**

2. Follow the plotting sticker, drill two holes, and secure the plastic anchors.

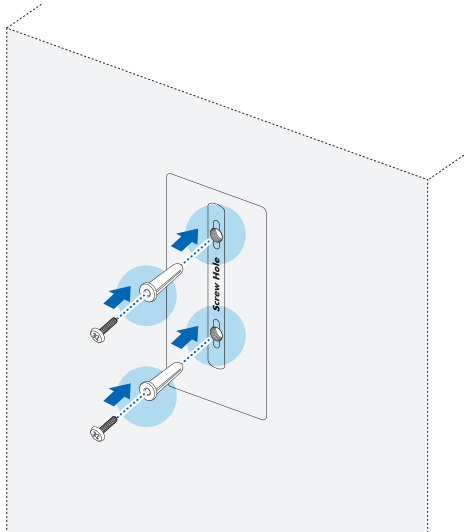

**Figure 2-5: Wall Mount (1 of 2)**

3. Install two screws into the plastic anchors, leaving enough of the screw protruding out to hang the ENS500EXT on.

4. Align the screw holes on the mounting bracket with the screws and then install the device on the wall.

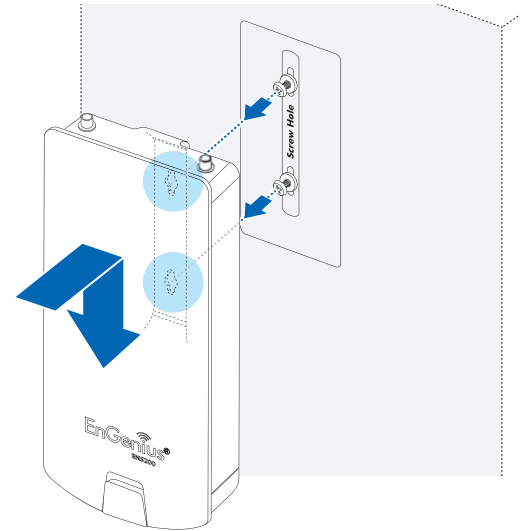

**Figure 2-6: Wall Mount (2 of 2)**

**Pole mount:**

1. Thread two cable ties through the mounting bracket on the back of the ENS500EXT.

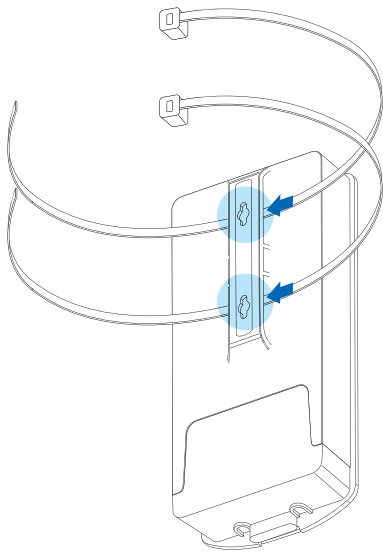

**Figure 2-7: Pole Mount (1 of 2)**

2. Position the ENS500EXT on a pole and secure both cable ties.

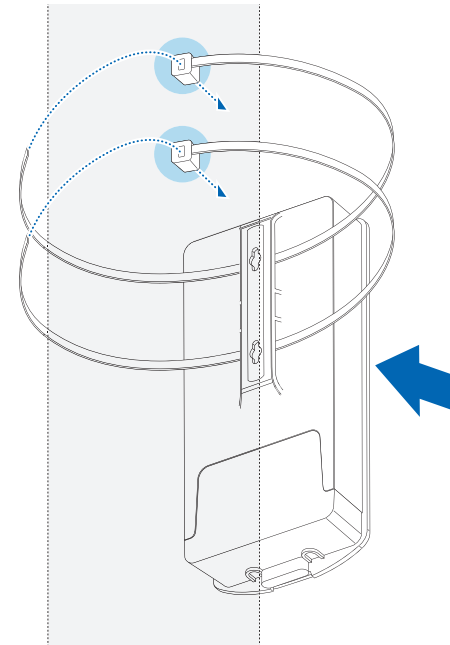

**Figure 2-8: Pole Mount (2 of 2)**

This completes the installation procedure.



# Web Configuration

Chapter 3

## 3.1 Logging In

The ENS500EXT has a built-in Web Configurator that lets you manage the unit from any location using a Web browser that supports HTTP and has Javascript installed.

After configuring the computer for TCP/IP using the procedure appropriate for your operating system, use that computer's Web browser to log in to the ENS500EXT Web Configurator.

1. Launch your Web browser.
2. In the browser address bar, type **192.168.1.1** and press the Enter key.

**Note:**

If you changed the ENS500EXT LAN IP address, enter the correct IP address.

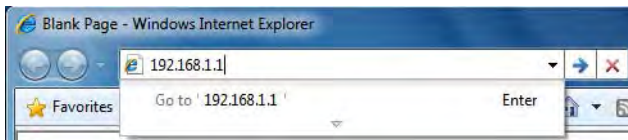

**Figure 3-1: Web Browser Address Bar**

3. When the login screen appears, enter **admin** for the user-name in the top field and **admin** for the password in the bottom field.

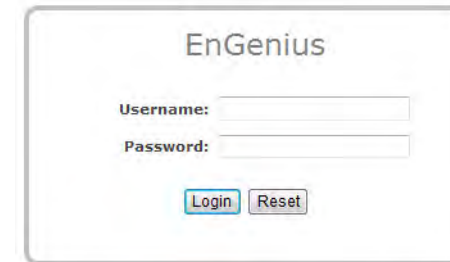

**Figure 3-2: Windows Security Login Dialog**

4. Click **Login** to continue or **Reset** to abort the login.

You are now ready to use the instructions in the following chapters to configure the ENS500EXT.

## Best Practices

Perform the following procedures regularly to make the ENS500EXT more secure and manage the ENS500EXT more effectively.

- **Change the default password** Use a password that is not easy to guess and that contains different characters, such as numbers and letters. The ENS500EXT username cannot be changed. For more information, see *Configuring Administrator Account*.
- **Back up the configuration** and be sure you know how to restore it. Restoring an earlier working configuration can be useful if the ENS500EXT becomes unstable or crashes. If you forget your password, you will have to reset the ENS500EXT to its factory default settings and lose any customized override settings you configured. However, if you back up an earlier configuration, you will not have to completely reconfigure the ENS500EXT. You can simply restore your last configuration. For more information, see *Configuring Backup/Restore Settings*.

# Basic Network Settings

Chapter 4

## 4.1 System Status

View the summary of the current system status including system (hardware/software version, date/time), wired network (LAN) and wireless network (WLAN) information.

### 4.1.1 Using Save/Reload

Save and apply the settings shown in the Unsaved changes list, or cancel the unsaved changes and revert to the previous settings that were in effect.



The screenshot displays a web interface for saving and reloading settings. At the top right, there are two buttons: "Home" and "Reset". Below these is a horizontal line. The main heading is "Save/Reload". Underneath, there is a section titled "Unsaved changes list" with a blue header. The list contains two entries: "network.sys.opmode=ap'" and "wireless.wifi0.countryName=N/A". Below the list is a red warning box with the text "Caution: Network Setting changed, redirect IP to 192.168.1.1". At the bottom, there are two buttons: "Save & Apply" and "Revert".

## 4.1.2 Viewing System Information

Displays status information about the current operating mode.

**System Information** shows the general system information such as operating mode, system up time, firmware version, serial number, kernel version, and application version.

**LAN Settings** shows Local Area Network settings such as the LAN IP address, subnet mask, and MAC address.

### System Information

Device Name	ENS500EXT
Ethernet Main MAC Address	00:02:6F:FF:FF:FF
Ethernet Secondary MAC Address	00:02:6F:FF:FF:FF
Wireless MAC Address	00:02:6F:EC:30:C4
Country	N/A
Current Time	Mon Jan 7 09:47:32 UTC 2013
Firmware Version	1.2.9

### LAN Settings

IP Address	192.168.1.1
Subnet Mask	255.255.255.0
Default Gateway	192.168.1.1
Primary DNS	0.0.0.0
Secondary DNS	0.0.0.0
DHCP Client	Disabled
IPv6 IP Address	None
IPv6 Link-Local Address	FE80::202:6FFF:FE11:2207
IPv6 Default Gateway	
IPv6 Primary DNS	
IPv6 Secondary DNS	
RX(Packets)	588.181 KB (4270 PKts.)
TX(Packets)	671.421 KB (5395 PKts.)

**WAN Settings** shows Wide Area Network settings such as the MAC address, connection type, connection status, WAN IP address, subnet mask, primary and secondary DNS.

WAN Settings	
MAC Address	00:02:6F:11:22:07
Connection Type	DHCP
Connection Status	Down
IP Address	
IP Subnet Mask	255.255.255.0
Primary DNS	
Secondary DNS	
RX(Packets)	0 B (0 PKts.)
TX(Packets)	32.3955 KB (678 PKts.)

**Current Wireless Settings** shows wireless information such as frequency and channel. Since the ENS500EXT supports multiple-SSIDs, information about each SSID, such as its ESSID and security settings, are displayed.

Current Wireless Settings	
Operation Mode	Client Router
Wireless Mode	802.11 A/N Mixed
Channel Bandwidth	20/40 MHz
Frequency/Channel	5.32 GHz (Channel 64)
Wireless Network Name (SSID)	AP SSID
Security	None
Distance	1 Km
RX(Packets)	0 B (0 PKts.)
TX(Packets)	10.1621 KB (242 PKts.)

## 4.1.3 Viewing Wireless Client List

### Client List

[Home](#)[Reset](#)

SSID:#	MAC Address	TX(Bytes)	RX(Bytes)	RSSI(dBm)	Kick and Ban
--------	-------------	-----------	-----------	-----------	--------------

[Refresh](#)

Displays a list of clients associated to the ENS500EXT, along with the MAC addresses and signal strength for each client. To remove an SSID client from the list, click the button that appears in the Kick and Ban column.

Click the `Refresh` button to update the client list.



## 4.1.4 Viewing System Log

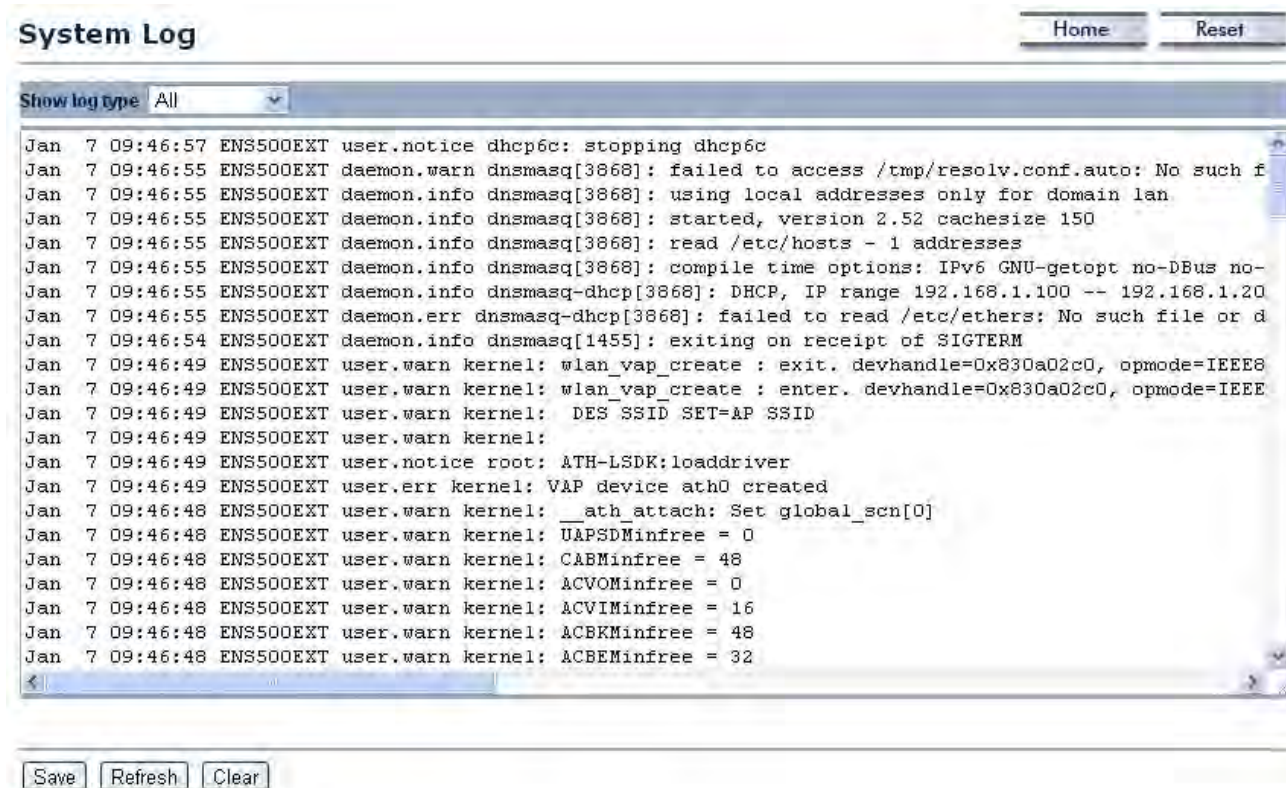

The ENS500EXT automatically logs events to internal memory.

### Note:

The oldest events are deleted from the log when memory is full.

Click the **Save** button to save the log information to a text file, click the **Refresh** button to update the client list, or the **Clear** button to remove all events.

## 4.1.5 Viewing Connection Status

Displays the current status of the network.

The WLAN information shown includes network type, SSID, BSSID, connection status, wireless mode, current channel, security, data rate, noise level, and signal strength.

Wireless	
Network Type	Client Router
SSID	AP SSID
BSSID	N/A
Connection Status	N/A
Wireless Mode	N/A
Current Channel	N/A
Security	N/A
Tx Data Rates(Mbps)	N/A
Current noise level	N/A
Signal strength	N/A

The WAN information shown includes the MAC address, connection type, connection status, IP address, IP subnet mask, primary DNS and secondary DNS.

WAN	
MAC Address	00:02:6F:E4:61:C0
Connection Type	DHCP <input type="button" value="Renew"/> <input type="button" value="Release"/>
Connection Status	Down
IP Address	
IP Subnet Mask	255.255.255.0
Primary DNS	
Secondary DNS	

Click the Refresh button to update connections status.

## 4.1.6 Viewing DHCP Client Table

**DHCP Client List**

---

MAC addr	IP	Expires
<input type="button" value="Refresh"/>		

Displays the clients that are associated to the ENS500EXT through DHCP. The MAC addresses, IP addresses, and expiry times period for each client are shown in separate rows.

Click the `Refresh` button to update the client table.

## 4.1.7 Viewing WDS Link List

### WDS Link Status

Home

Reset

WDS Link ID	MAC Address	Link Status	RSSI (dBm)
-------------	-------------	-------------	------------

Refresh

Displays the clients that are associated to the ENS500EXT through WDS. The MAC addresses, link status and signal strength for each client are also shown.

Click the Refresh button to update the client list.

## 4.2 System Setup

The following sections explain the features and functionality of the ENS500EXT in access point mode, client bridge mode, WDS access point mode, WDS bridge mode, WDS station mode and client router mode.

### 4.2.1 Configuring Operation Mode

Set the primary function of the device. The function that is selected affects which items are available in the main menu.

**Device Name** Enter a name for the device. The name you type appears in SNMP management. This name is not the SSID and is not broadcast to other devices.

**Country/Region** United States

**Operation Mode** Use the radio button to select an operating mode.

Click **Save & Apply** to save changes or **Cancel** to abort.

#### System Properties

##### System Properties

Device Name	ENS500EXT ( 1 to 32 characters )
Country/Region	United States
Operation Mode	<input type="radio"/> Access Point <input type="radio"/> Client Bridge <input checked="" type="radio"/> WDS <input checked="" type="radio"/> Access Point <input type="radio"/> Bridge <input type="radio"/> Station <input type="radio"/> Client Router

Save & Apply

Cancel

## 4.2.2 Configuring IP Settings

Configure the ENS500EXT LAN settings for the ENS500EXT using a static or dynamic IP address.

**IP Network Setting** Configure the network connection type using either a static IP or dynamic IP.

**IP Address** Enter the LAN IP address of the ENS500EXT.

**Subnet Mask** Enter the subnet mask of the ENS500EXT.

**Default Gateway** Enter the default gateway of the ENS500EXT.

**Primary DNS** Enter the primary DNS address of the ENS500EXT.

**Secondary DNS** Enter the secondary DNS address of the ENS500EXT.

**Use Link-Local Address** Click to enable a link-local address for the device.

**IPv6 IP Address** Enter the IPv6 LAN IP address of the ENS500EXT.

**IPv6 Subnet Prefix Length** Enter the IPv6 subnet prefix length of the ENS500EXT.

**IPv6 Default Gateway** Enter the IPv6 default gateway of the ENS500EXT.

**IPv6 Primary DNS** Enter the IPv6 primary DNS of the ENS500EXT.

**IPv6 Secondary DNS** Enter the IPv6 secondary DNS of the ENS500EXT.

Click **Apply** to save the settings or **Cancel** to discard changes.

### IP Settings

System Information	
IP Network Setting	<input type="radio"/> Obtain an IP address automatically (DHCP) <input checked="" type="radio"/> Specify an IP address
IP Address	192 . 168 . 1 . 220
IP Subnet Mask	255 . 255 . 255 . 0
Default Gateway	192 . 168 . 1 . 1
Primary DNS	0 . 0 . 0 . 0
Secondary DNS	0 . 0 . 0 . 0
Use Link-Local Address	<input checked="" type="checkbox"/>
IPv6 IP Address	<input type="text"/>
IPv6 Subnet Prefix Length	<input type="text"/>
IPv6 Default Gateway	<input type="text"/>
IPv6 Primary DNS	<input type="text"/>
IPv6 Secondary DNS	<input type="text"/>

## 4.2.3 Configuring Spanning Tree Settings

**Spanning Tree Status** Enable or disable the ENS500EXT Spanning Tree function.

**Bridge Hello Time** Specify Bridge Hello Time, in seconds. This value determines how often the ENS500EXT sends hello packets to communicate information about the topology throughout the entire Bridged Local Area Network

**Bridge Max Age** Specify Bridge Max Age, in seconds. If another bridge in the spanning tree does not send a hello packet for a long period of time, it is assumed to be dead.

**Bridge Forward Delay** Specify Bridge Forward Delay, in seconds. Forwarding delay time is the time spent in each of the Listening and Learning states before the Forwarding state is entered. This delay is provided so that when a new bridge comes onto a busy network, it looks at some traffic before participating.

**Priority** Specify the Priority number. Smaller numbers have greater priority.

Click `Accept` to confirm the changes or `Cancel` to cancel and return previous settings.

### Spanning Tree Settings

Spanning Tree Status	<input type="radio"/> On <input checked="" type="radio"/> Off
Bridge Hello Time	2 seconds (1-10)
Bridge Max Age	20 seconds (6-40)
Bridge Forward Delay	4 seconds (4-30)
Priority	32768 (0-65535)

Accept

Cancel

## 4.3 Router Setup

### 4.3.1 Configuring WAN Settings

Configure the WAN settings for the ENS500EXT using a static or dynamic IP address, PPPoE or PPTP.

#### Static IP

Setting a static IP address allows an administrator to set a specific IP address for the router and guarantees that it can not be assigned a different address.

**Account Name** Enter the account name provided by your ISP.

**Domain Name** Enter the domain name provided by your ISP.

**MTU** The maximum transmission unit (MTU) specifies the largest packet size permitted for an internet transmission. The factory default MTU size for static IP is 1500. The MTU size can be set between 512 and 1500.

**IP Address** Enter the router's WAN IP address.

**Subnet Mask** Enter the router's WAN subnet mask.

**Default Gateway** Enter the WAN gateway address.

**Primary DNS** Enter the primary DNS server address.

**WAN Settings** Home Reset

Internet Connection Type: Static IP

Options

Account Name (if required):

Domain Name (if required):

MTU: Auto 1500 ( 576 - 1500 )

Internet IP Address

IP Address: 192 . 168 . 10 . 1

IP Subnet Mask: 255 . 255 . 255 . 0

Gateway IP Address: 0 . 0 . 0 . 0

Domain Name Server (DNS) Address

Primary DNS: 0 . 0 . 0 . 0

Secondary DNS: 0 . 0 . 0 . 0

WAN Ping

Discard Ping on WAN:

Accept Cancel