

# User Manual



EnStation5-ACv2



ENS500-ACv2



ENS500EXT-ACv2

version 1.0

AC867 5GHz  
Outdoor Long Range Wireless Access Point

# IMPORTANT

To install this Access Point please refer to the **Quick Installation Guide** included in the product packaging.

# Table of Contents

<b>Chapter 1 Product Overview.....</b>	<b>4</b>	Wireless Security.....	45
Key Features/Introduction.....	5	Fast Roaming.....	46
System Requirements.....	6	Wireless MAC Filtering.....	47
Package Contents.....	7	Wireless Traffic Shaping.....	45
Technical Specifications.....	8	Guest Network Settings.....	49
Physical Interface.....	10	Management VLAN Setting.....	50
<b>Chapter 2 Before You Begin.....</b>	<b>12</b>	<b>Chapter 8 Management .....</b>	<b>51</b>
Computer Settings.....	13	Advanced Settings.....	52
Hardware Installation.....	17/21	CLI Settings/Email Alert.....	53
Mounting the Device.....	18/22	Time Zone.....	55
<b>Chapter 3 Configuring Your Access Point.....</b>	<b>24</b>	Auto Reboot Settings.....	56
Default Settings./Web Configuration.....	25	Wi-Fi Scheduler.....	57
<b>Chapter 4 Building a Wireless Network.....</b>	<b>26</b>	Tools.....	58
Access Point .....	27	Account/Firmware.....	60
Client Bridge Mode.....	28	Backup/Restore .....	61
WDS AP Mode.....	29	Log.....	63
WDS Bridge Mode.....	30	Logout/Reset.....	64
WDS Station Mode.....	31	<b>Appendix.....</b>	<b>65</b>
<b>Chapter 5 Status.....</b>	<b>32</b>	FCC Interference Statement.....	66
Main Status.....	33	Professional Installation Instruction (FCC).....	67
Connection.....	35	IC Interference Statement.....	68
<b>Chapter 6 Network .....</b>	<b>37</b>	Professional installation instruction (IC).....	70
Basic IP Settings.....	38		
Spanning Tree Protocol Setting.....	38		
<b>Chapter 7 Wireless.....</b>	<b>40</b>		
Wireless Settings.....	41		
Wireless Network.....	42		
SSID Profile.....	43		

# Chapter 1

# **Product Overview**



# Introduction

## Key Features

- Supports IEEE802.11ac/a/n wireless standards with up to 867 Mbps data rate.
- Internal 15.5dBi high gain directional antenna(EnStation5-ACv2);Internal 13.42dBi high gain directional antenna(ENS500-ACv2);
- External 5.17dBi dipole antenna(ENS500EXT-ACv2)
- Can be used with included 24V PoE adapter
- Secured Guest Network option available
- Advanced 256-QAM technology to achieve optimal performance throughout ultra-long distance

## Introduction

The EnStation5-ACv2/ENS500-ACv2/ENS500EXT-ACv2 is a high-powered, ultra long-range 2x2 Wireless 802.11ac/a/n Outdoor Access Point with speeds up to 867 Mbps on both its high-powered 5 GHz radios. Built in EnGenius EnJet solution, AP can transmit data more efficiently, avoid collisions, and reduce latency and packet losses. It can be configured as an: Access Point, Client Bridge or WDS (AP & Station) when EnJet enable, or Access Point, Client Bridge or WDS (AP, Station & Bridge) when EnJet disable. The EnStation5-ACv2/ENS500-ACv2/ENS500EXT-ACv2 is designed to operate in a variety of outdoor environments. Its high-powered, long-range characteristics make it a cost



EnStation5-ACv2



ENS500-ACv2/ETD500EXT

effective alternative to ordinary Access Points that don't have the range and reach to connect to a growing number of wireless CPEs who wish to connect to a business network. The EnStation5-ACv2/ENS500-ACv2/ENS500EXT-ACv2 supports the 5 GHz frequency band for communicating to other 5GHz frequency bands Access Points concurrently.

Maximum data rates are based on IEEE 802.11 standards. Actual throughput and range may vary depending on many factors including environmental conditions, distance between devices, radio interference in the operating environment, and mix of devices in the network. Features and specifications subject to change without notice. Trademarks and registered trademarks are the property of their respective owners. For United States of America: Copyright © 2018 EnGenius Technologies, Inc. All rights reserved.

Several EnStation5-ACv2/ENS500-ACv2/ENS500EXT-ACv2s can be networked in a campus setting using the 5 GHz band between countries, which is easy to be installed in virtually any location with its included PoE (Power over Ethernet) Adapter for quick outdoor installation. The EnStation5-ACv2/ENS500-ACv2/ENS500EXT-ACv2 enables network administrators to control its transmit power and features settings for selecting VHT80 bandwidth to perform true AC transmission. When EnJet enable, administrators can adjust the AP time slot and Station Priority to maximize transmission efficiency. It also supports wireless encryption including Wi-Fi Protected Access (WPA2-PSK) Encryption and IEEE 802.1X with RADIUS.)

## System Requirements

The following are the Minimum System Requirements in order to configure the device.

- Computer with an Ethernet interface or wireless network capability
- Windows OS (XP, Vista, 7, 8, 10), Mac OS, or Linux-based operating systems
- Web-Browsing Application (i.e.: Internet Explorer, Firefox, Safari, or another similar browser application)

## Package Contents

The EnStation5-ACv2 package contains the following items:\*

- EnStation5-ACv2 Customer Premises Equipment
- PoE Adapter (EPA2406GP)
- Power Cord
- Pole Mount Strap
- Wall Mount Bracket Base
- Screw Sets Kit
- Rubber
- Sealing Nut
- Dynamic Stick
- Quick Installation Guide

\*(all items must be in package to issue a refund):

# Technical Specifications

## Standard:

IEEE802.11ac wave2/a/n on 5 GHz

## Antenna

Internal 15.5dBi high gain directional antenna (EnStation5-ACv2)

Internal 13.42dBi high gain directional antenna (ENS500-ACv2)

External 2\*5.17dBi detachable antenna (ENS500EXT-ACv2)

## Physical Interface

2 x 10/100/1000 Gigabit Ethernet Port with PoE support

LAN(PoE) Port supports 24V PoE Input

## LED Indicator

Power

LAN 1

LAN 2

WLAN

WLAN LED (Weak, Medium, Strong)

## Power Requirements

Include PoE Adapter, 24V/0.6A

## Operation Modes-EnJet enable

Access Point

Client Bridge

WDS AP

WDS Station

## Operation Modes-EnJet disable

Access Point

Client Bridge

WDS AP

WDS Bridge

WDS Station

## Optimal Performance

Distance Control (Ack Timeout)

Multicast Supported

Data Rate Selection

Auto Channel Selection

BSSID Support

AP Time Slot

Station Priority

## Easily Management

VLAN Tag / VLAN Pass-through

Guest Network

QoS: Complaint with IEEE 802.11e /WMM

RADIUS Accounting

Wireless STA (Client) connection list

Traffic Shaping (Per SSID)

## Intuitive Tools

SNMP v1/v2c/v3 support

MIB I/II, Private MIB

Save Configuration as Default

CLI Support

WiFi-Scheduler/Auto Reboot

E-mail Alert

## Reinforcement Security

WPA2 Enterprise

Hide SSID in beacons

MAC address filtering, up to 32 MACs per SSID

Wireless STA (Client) connection list

Https Support

SSH Support



## **QoS (Quality of Service)**

Compliant with IEEE 802.11e standard

## **Physical/Environment Conditions**

Operating:

Temperature: -20 °C to 60 °C (-4 °F to 140 °F)

Humidity (non-condensing): 90% or less

Storage:

Temperature: -30 °C to 80 °C (-22 °F to 176 °F)

Humidity (non-condensing): 90% or less

# Physical Interface-EnStation5-ACv2

## Dimensions and Weights

### EnStation5-ACv2

Dimension: 190mm (7.48")

Height: 38mm (1.9")

Weight: 527g (1.16 lbs)

### 1 WLAN Signal LED: Applied on Client Bridge/WDS

(1) Red: Weak Signal: Connecting quality is bad.

(2) Yellow: Connecting quality is Normal.

(3) Green: Connection quality is Good.

### 2 LAN(PoE) Signal LED

### 3 LAN Signal LED of the 2nd Port

### 4 Power Signal:

5 LAN Port 1: Gigabit Ethernet port for RJ-45 cable.

6 LAN Port 2: Gigabit Ethernet port for RJ-45 cable.



# Physical Interface - ENS500-ACv2/ENS500EXT-ACv2

## Dimensions

Length: 186 mm (7.32")

Width: 100 (3.94")

Depth: 29mm (1.14")

- 1 **5 GHz Antennas** Detachable 5 dBi 5 GHz Omni-directional Antennas (ENS500EXT-ACv2 Only)
- 2 **LAN Port 1 (Proprietary 24V PoE)**: Ethernet port for RJ-45 cable.
- 3 **LAN Port 2** : Ethernet port for RJ-45 cable.
- 4 **LED Indicators**: LED lights for Power, LAN Port 1, LAN Port 2, 2.4 GHz Connection and 5 GHz Connection.
- 5 **Mounting Holes**: Using the provided hardware, the AP can be attached to a wall or pole.

\*The installation angle of antenna must be vertical to the ground.

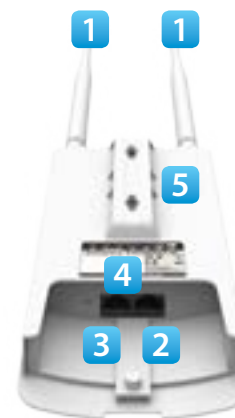

# Chapter 2

## **Before You Begin**



# Computer Settings

## Windows XP/Windows 7/Windows 8/Windows 10

In order to use the Access Point, you must first configure the TCP/IPv4 connection of your Windows OS computer system.

1a. Click the **Start** button and open the **Control Panel**



Windows XP



Windows 7

1b. Move your mouse to the lower right hot corner to display the Charms Bar and select the **Control Panel** in Windows 8 OS.



Windows 8

1c. In Windows 10, click **Start** to select **All APPs** to enter the folder of **Windows system** for selecting **Control Panel**.

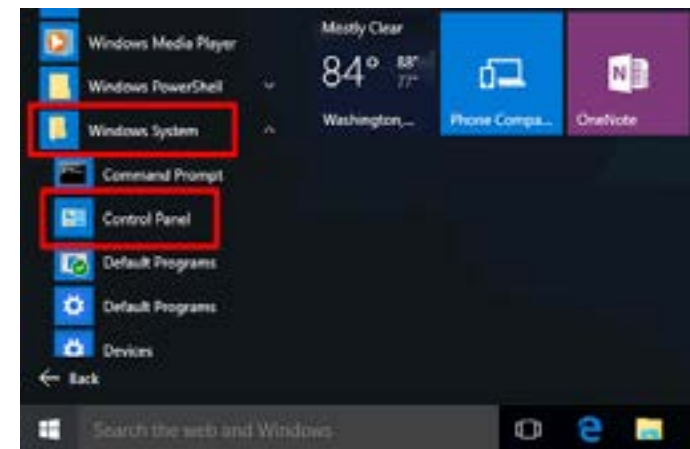

Windows 10

2a. In Windows XP, click **Network Connections**.



2b. In Windows 7/Windows 8/Windows 10, click **View Network Status and Tasks** in the **Network and Internet** section, then select **Change adapter settings**.



3. Right click on **Local Area Connection** and select **Properties**.

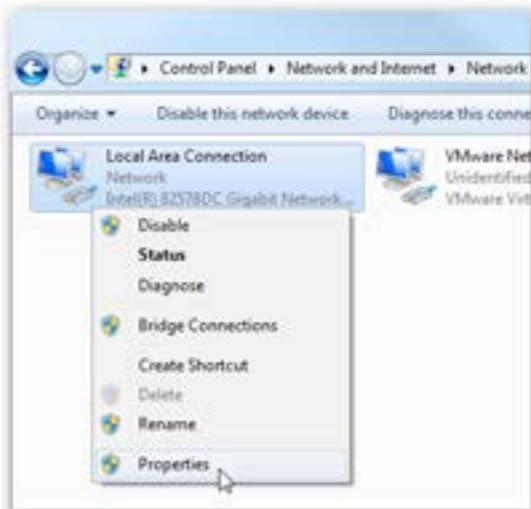

4. Select **Internet Protocol Version 4 (TCP/IPv4)** and then select **Properties**.

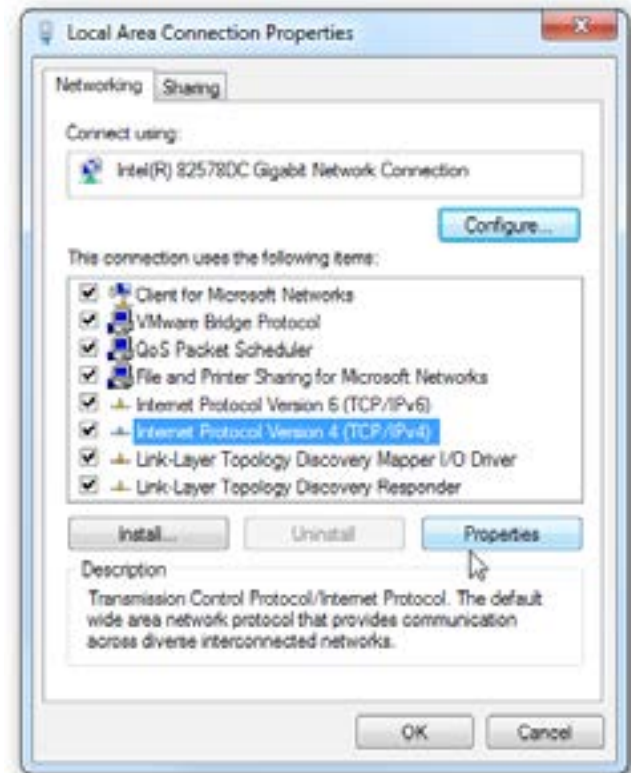

5. Select **Use the following IP address** and enter an IP address that is different from the Access Point and Subnet mask, then click **OK**.

**Note:** Ensure that the IP address and Subnet mask are on the same subnet as the device.

For example: ENH220EXT IP address: 192.168.1.1

PC IP address: 192.168.1.2 - 192.168.1.255

PC Subnet mask: 255.255.255.0



## Apple Mac OS X

1. Go to **System Preferences** (Which can be opened in the Applications folder or selecting it in the Apple Menu).
2. Select **Network** in the **Internet & Network** section.



3. Highlight **Ethernet**.

4. In **Configure IPv4**, select **Manually**.
5. Enter an IP address that is different from the Access Point and Subnet mask then press **OK**.

**Note:** Ensure that the IP address and Subnet mask are on the same subnet as the device.

For example: ENH900EXT IP address: 192.168.1.1

PC IP address: 192.168.1.2 - 192.168.1.255

PC Subnet mask: 255.255.255.0

6. Click **Apply** when done.

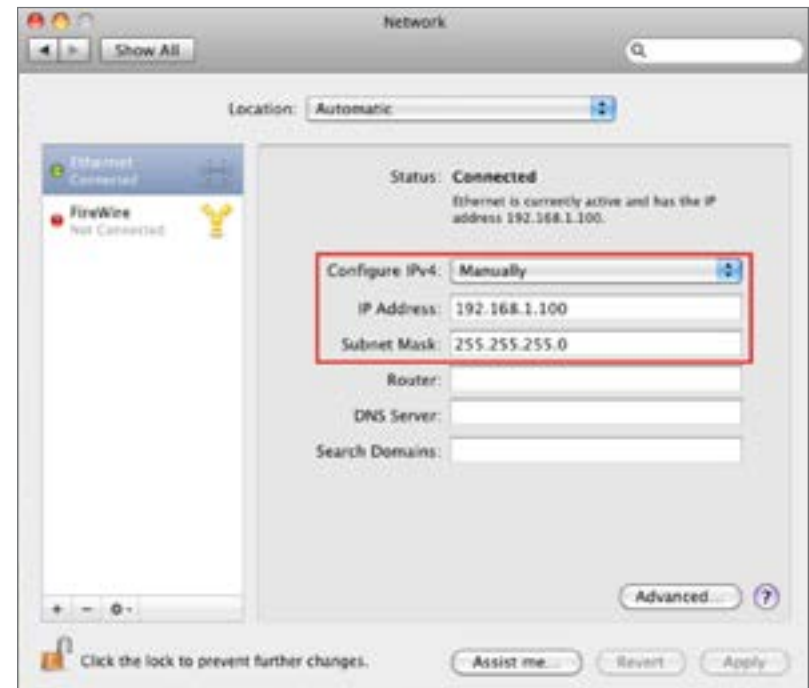



# Hardware Installation

## EnStation5-ACv2

1. Remove the rear bottom panel.
2. Connect one end of the Ethernet cable into the main LAN port (PoE) of the Access Point and the other end to the AP Ethernet port on the PoE Adapter.
3. Connect the Power cord to the **PoE Adapter** and plug the other end in to an electrical outlet.
4. Connect the second Ethernet cable into the **LAN port** of the PoE Adapter and the other end to the Ethernet port on the computer.
5. Place the panel back into device

**Note:** The EnStation5-ACv2 should ONLY be powered via Ethernet cable connected to included supports both IEEE 802.3at PoE (Power over Ethernet) or the included PoE Adapter. You may use either one as the power source. **Do NOT use both at the same time.**

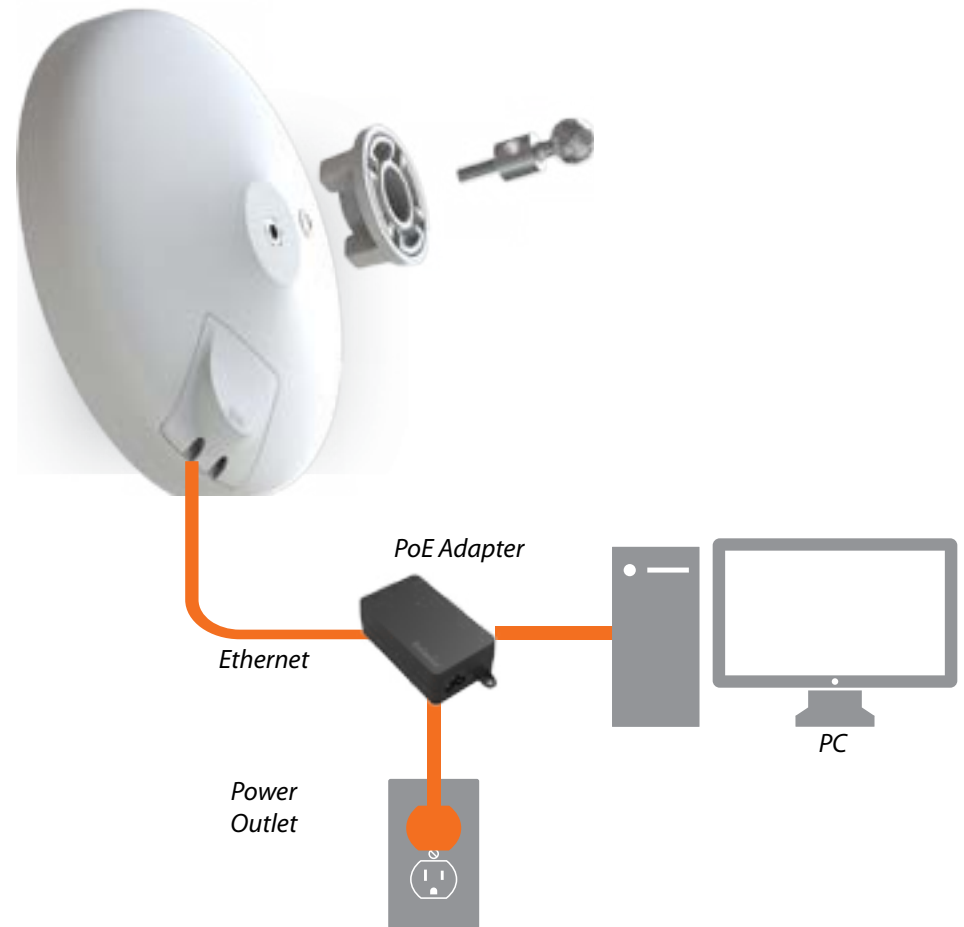

# Mounting the EnStation5-ACv2

Using the provided hardware, the EnStation5-ACv2 can be attached to a wall or a pole.

1. ETD

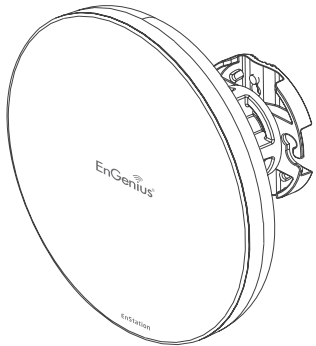

2. PoE Adapter & Power Cord



3. Bracket

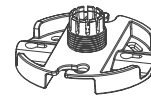

4. Pole Mounting Strap



5. Screw Set Kit

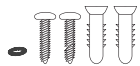

6. Sealing Nut

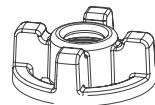

7. Dynamic Stick



8. Rubber



## Wall mounting the EnStation5-ACv2

1. Put the included rubber into the bracket.
2. Plug the dynamic stick into the bracket.
3. Screw the sealing nut and assembled parts, as well as tighten it.
4. Put the nock washer on the dynamic stick.
5. Assemble the mounting parts to the EnStation.

6. Determine the mounting location. Mark and drill two pilot holes aligning to the screw holes of the bracket.
7. Put wall anchors into the holes and insert screw into the wall anchor.
8. Screw and secure the bracket in the place.

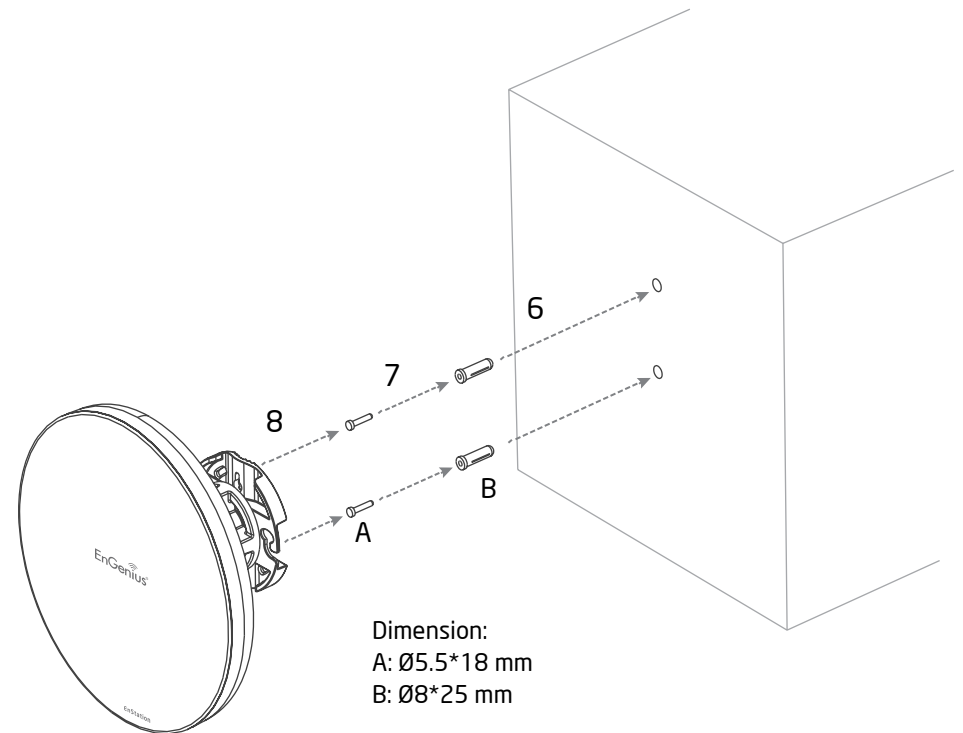
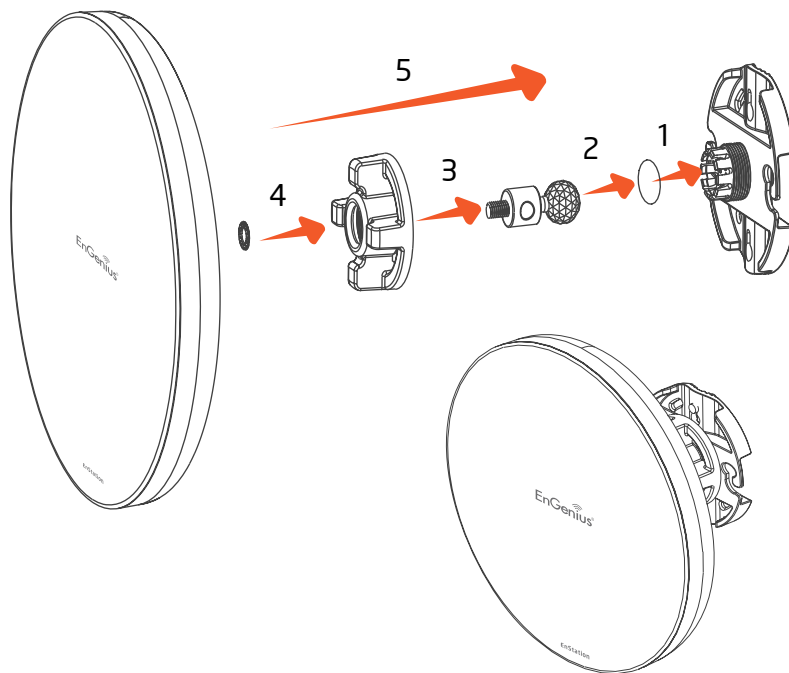

## Pole mounting the EnStation5-ACv2

1. Put the included rubber into the bracket.
2. Plug the dynamic stick into the bracket.
3. Screw the sealing nut and assembled parts, as well as tighten it.
4. Put the nock washer on the dynamic stick.
5. Assemble the mounting parts to the EnStation.

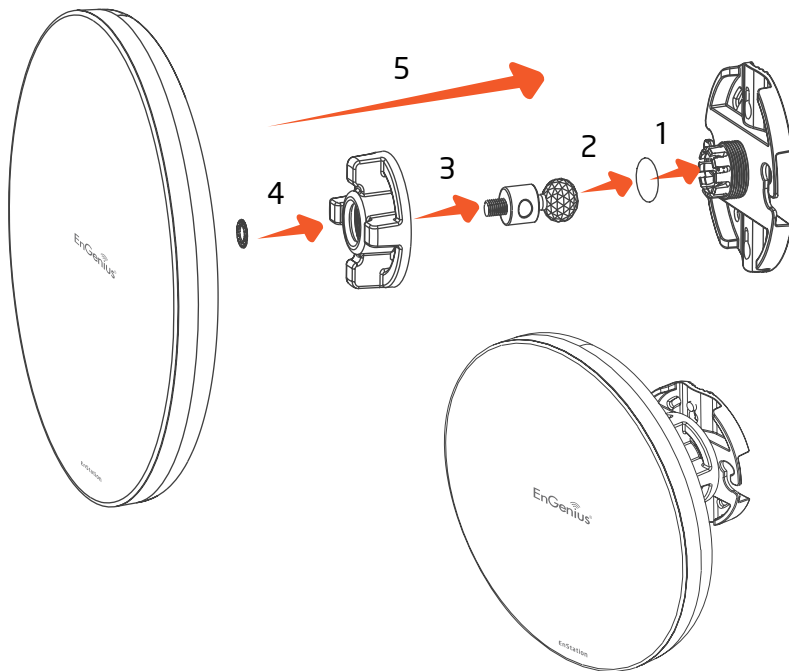

6. Thread the open end of the pole strap through the two tabs on the bracket.
7. Lock and tighten pole strap to secure bracket to the pole.

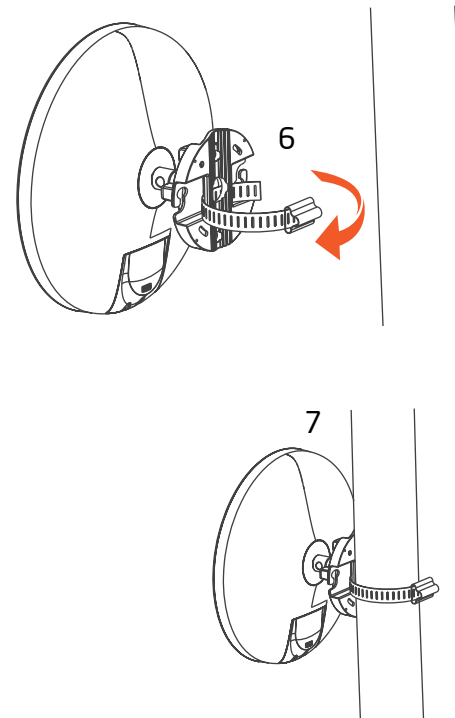

# Hardware Installation

## ENS500-ACv2/ENS500EXT-ACv2

1. Connect one end of the Ethernet cable into the LAN port (PoE) of the AP/ Bridge and the other end to the PoE port on the PoE adapter.
2. Connect the Power cord with the PoE Adapter and plug the other end into an electrical outlet.
3. Connect the second Ethernet cable into the LAN port of the PoE adapter and the other end to the Ethernet port on the computer.
4. Screw on the provided antennas to the top of this device.

Note: The AP/Bridge should ONLY be powered via Ethernet cable connected to the included PoE Adapter.

This diagram depicts the hardware configuration.

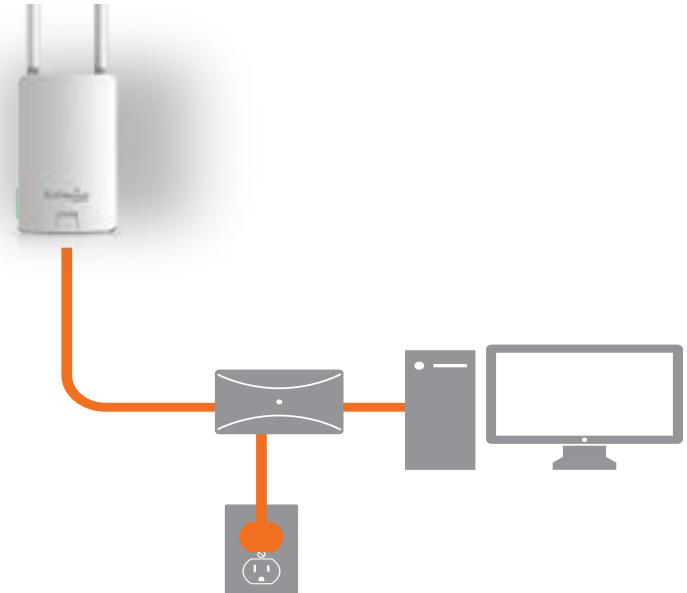

**Note:** The AP/Bridge should ONLY be powered via Ethernet cable connected to the included PoE Adapter.

# Mounting the ENS500-ACv2/ENS500EXT-ACv2

Using the provided hardware, the ENS202EXT can be attached to a wall or a pole. The height should not exceed 2 meter.

## 1. Wall Mounting Kit

(Anchors:  $\Phi 5.5 \times 18 \text{ mm}$  & Bolts:  $\Phi 8 \times 25 \text{ mm}$ )



## 2. Pole Mounting Strap

( $\Phi 66 \times 12.6 \text{ mm}$ )



**To attach the ENS500-ACv2/ENS500EXT-ACv2 to a wall using wall mounting kit.**

- A.** Determine where the Access Point to be placed and stick the Adhesive label on the surface.
- B.** Use the appropriate drill bit to drill two 8.1mm diameter and 26mm depth holes on the markings of the label.
- C.** Remove the label and screw the anchors into the holes until they are flush with the wall.
- D.** Screw the included screws into the anchors. Place the Access Point against wall with the mounting screw heads.

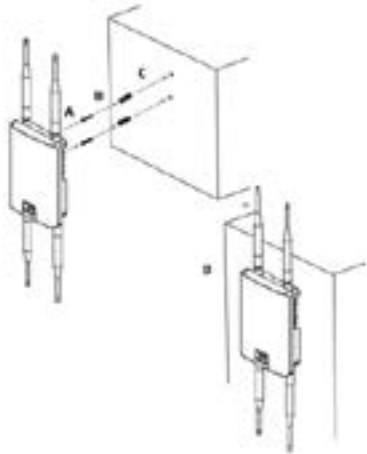

**To attach the ENS500EXT-ACv2 to a pole using the provided pole mounting kit:**

- A.** Thread the open end of the Pole Strap through the two tabs on the Pole Mount Bracket.
- B.** Lock and tighten Pole Strap to secure Pole Mount Bracket to the pole.

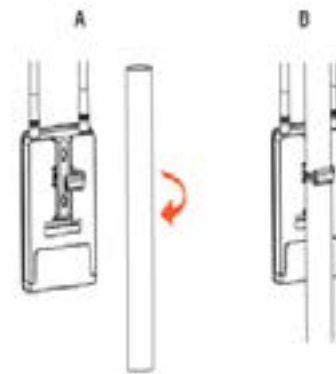

# Chapter 3

# **Configuring Your Access Point**





# Configuring Your Access Point

This section will show you how to configure the device using the web-based configuration interface.

## Default Settings

Please use your Ethernet port or wireless network adapter to connect the Access Point.

IP Address	192.168.1.1
Username / Password	admin / admin

## Web Configuration

1. Open a web browser (Internet Explorer/Firefox/Safari/Chrome) and enter the IP Address **http://192.168.1.1**

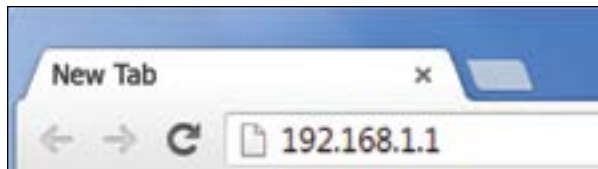

**Note:** If you have changed the default LAN IP Address of the Access Point, ensure you enter the correct IP Address.

2. The default username and password are **admin**. Once you have entered the correct username and password, click the **Login** button to open the web-base configuration page.



- \* The model name will be varied by different models
3. If successful, you will be logged in and see the EnStationAC User Interface.



# Chapter 4

# **Building a Wireless Network**



Before starting to configure this Access Point, you may realize the used scenario under varied operating modes. ETD series product is built in EnGenius EnJet solution, AP can transmit data more efficiently, avoid collisions, and reduce latency and packet losses. It can be configured as an: Access Point, Client Bridge or WDS (AP & Station) when EnJet enable, or Access Point, Client Bridge or WDS (AP, Station & Bridge) when EnJet disable. This chapter describes purpose of different operating modes and lists down the operating modes for outdoor Access Points or Client Premise Equipments (CPE).

## Access Point Mode

In Access Point Mode, AP/CPE behaves like a central connection for stations or clients that support IEEE 802.11a/b/g/n networks. The stations and clients must be configured to use the same SSID (Service Set Identifier) and security password to

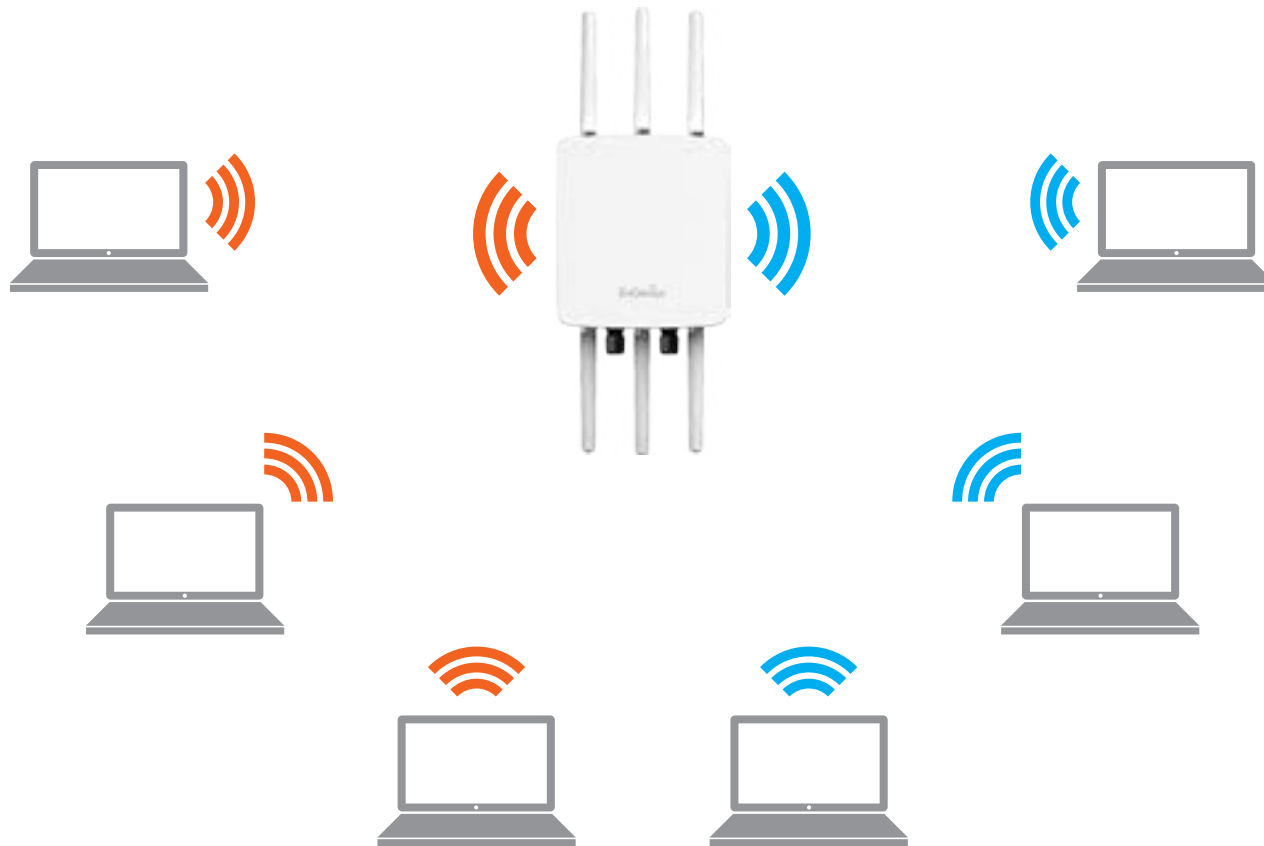

## Client Bridge Mode

The AP/CPE essentially acts as a wireless adapter that connects to an access point to allow a system of wireless access to the network in the Client Bridge mode. Since the computers are on the same subnet, the AP/CPE can broadcast to reach all end-devices.

If you use the client bridge mode in the AP/CPE, you can use the AP Detection feature to scan for Access Points within range. When you find an Access Point, configure the AP/CPE to use the same SSID and Security Password as the Access Point to associate with it.

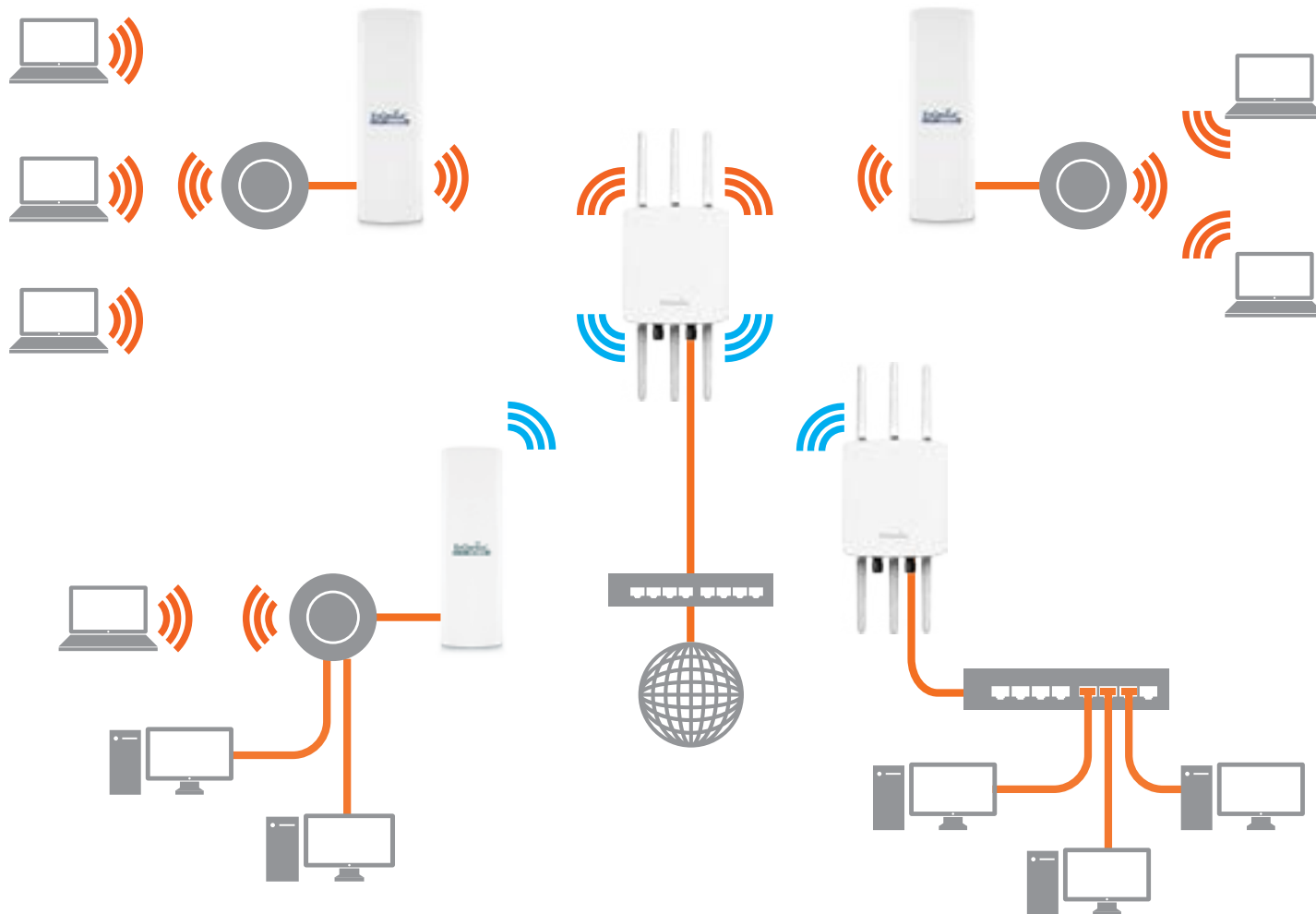

associate with the EnStationAC. The EnStationAC supports up to eight (8) SSIDs per band at the same time for secure access.

## WDS AP Mode

The AP/CPE also supports WDS AP mode. This operating mode allows wireless connections to the AP/CPE using WDS technology. In this mode, configure the MAC addresses in both Access Points to enlarge the wireless area by enabling

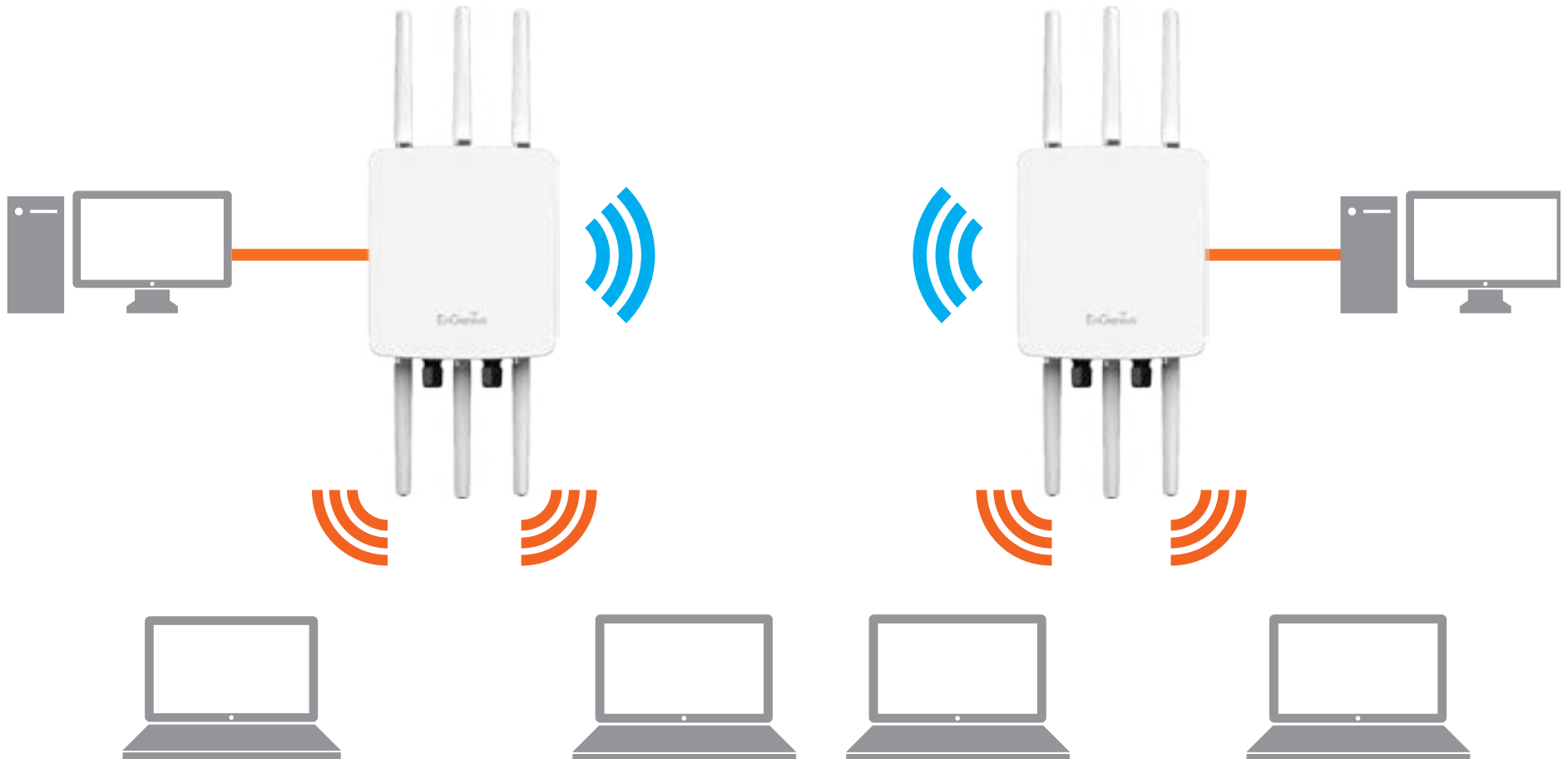

WDS Link settings. WDS supports up to four (4) AP MAC addresses.

## WDS Bridge Mode

In WDS Bridge Mode, the AP/CPE can wirelessly connect different LANs by configuring the MAC address and security settings of each AP/CPE device. Use this mode when two wired LANs located a small distance apart want to communicate with each other. The best solution is to use the AP/CPE to wirelessly connect two wired LANs, as shown in the following diagram.

WDS Bridge Mode can establish up to four WDS links, creating a star-like network.

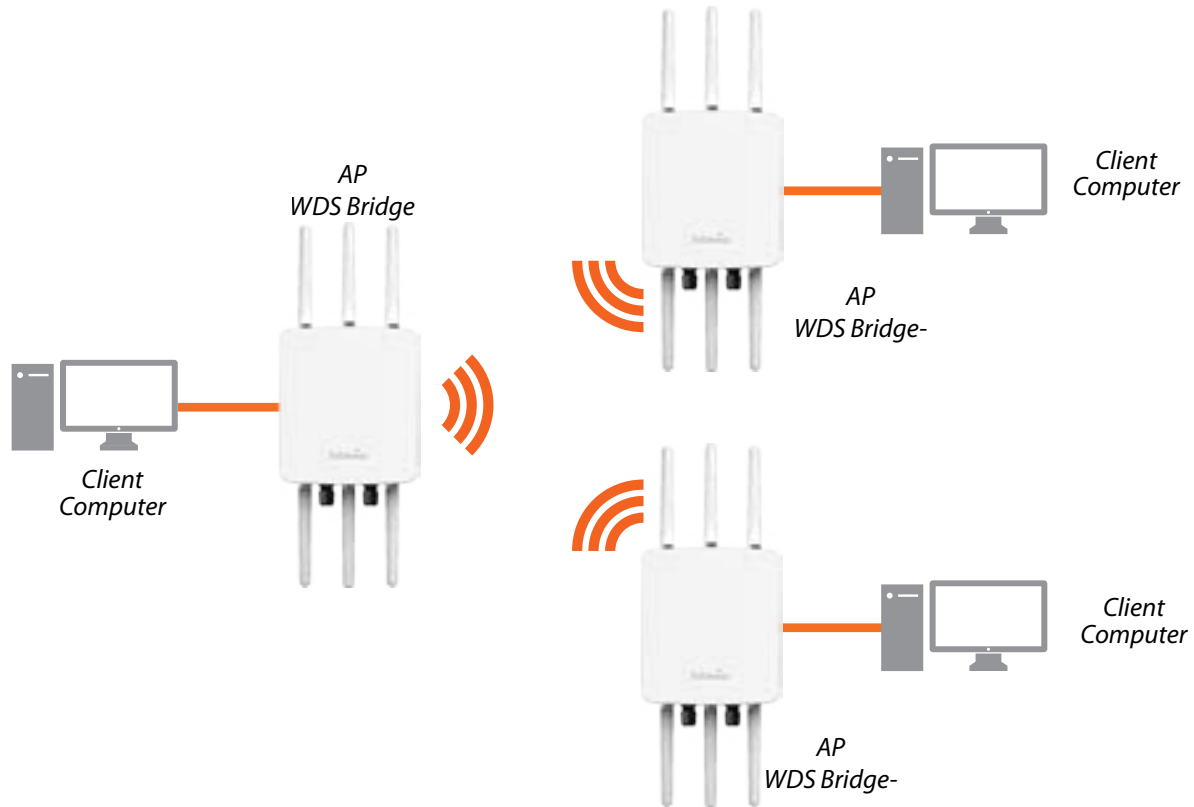

## WDS Station Mode

Station mode expands the WDS by receiving a wireless signal/service and sharing it through the Ethernet port.

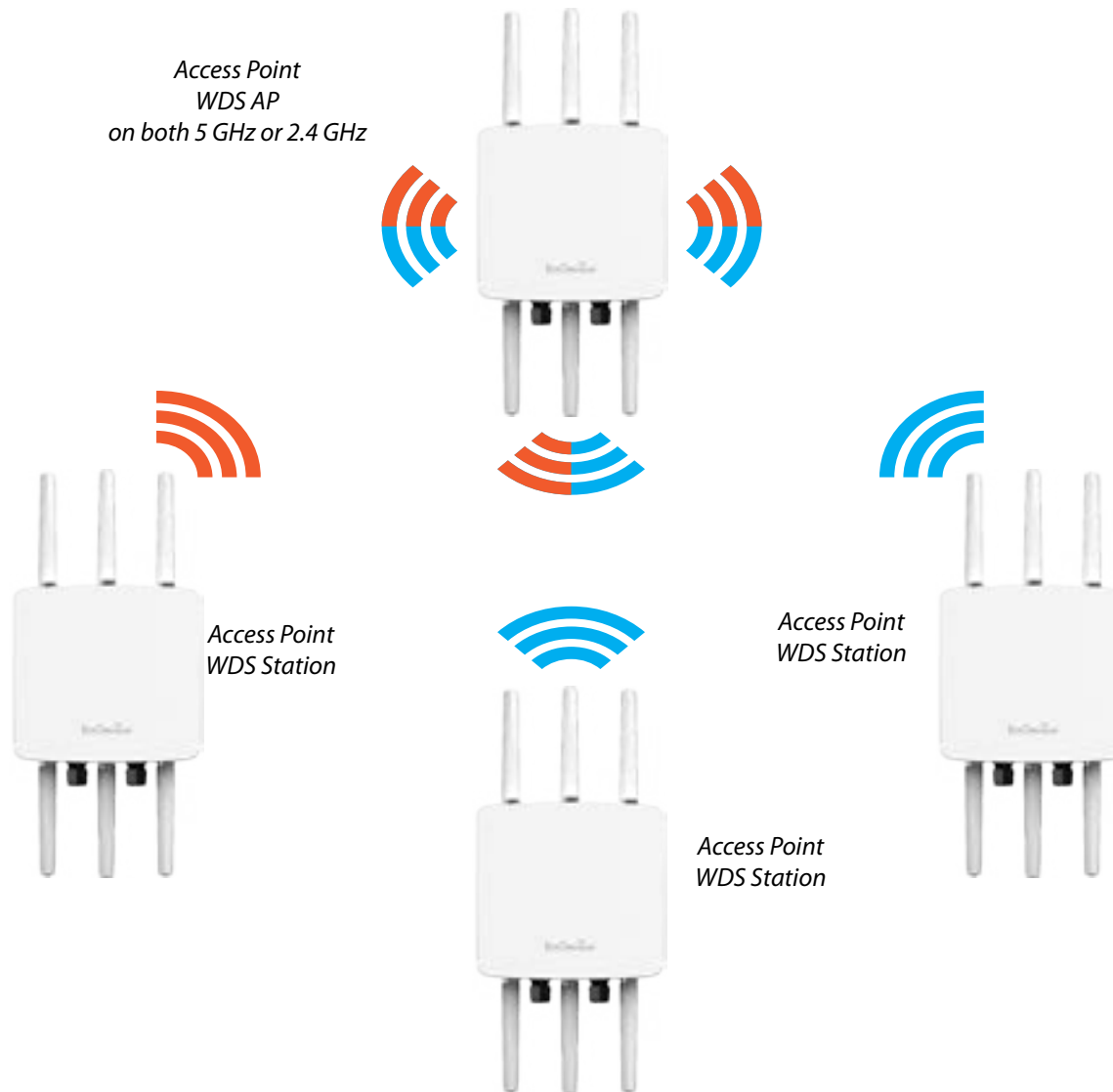

# Chapter 5

# Status





# Main Status

## Save Changes

This page lets you save and apply the settings shown under **Unsaved changes list**, or cancel the unsaved changes and revert to the previous settings that were in effect.



\*The model name will be varied by different models.

## Device Status

Clicking the **Device Status** link under the **Overview** menu shows the status information about the current operating mode.

- The **Device Information** section shows general system information such as Device Name, MAC Address, Current Time, Firmware Version, and Management VLAN ID

**Note:** VLAN ID information is only applicable in Access Point or WDS AP mode.

### Device Information

Device Name	ENG620EXT
MAC Address	
- LAN1	88-DC-96-00-00-10
- LAN2	88-DC-96-00-00-11
- Wireless LAN - 2.4GHz	88-DC-96-00-00-12
- Wireless LAN - 5GHz	88-DC-96-00-00-13
Country	USA
Current Local Time	Tue Jul 12 11:45:00 2016
Uptime	0h 4m 57s
Firmware Version	1.0.0
Management VLAN ID	Untagged

\*The model name will be varied by different models.

- The **Memory Information** section shows usage of memory such as Total Available, Free, Cached, Buffered

### Memory Information

Total Available	128884 kB / 336136 kB (34%)
Free	89352 kB / 236136 kB (40%)
Cached	24108 kB / 236136 kB (10%)
Buffered	8624 kB / 236136 kB (9%)

- The **LAN Information** section shows the Local Area Network settings such as the LAN IP Address, Subnet

LAN Information - IPv4	
IP Address	192.168.1.1
Subnet Mask	255.255.255.0
Gateway	192.168.1.1
Primary DNS	0.0.0.0
Secondary DNS	0.0.0.0
DHCP Client	Disable
Spanning Tree Protocol (STP)	Disable

- The **Wireless LAN Information 5 GHz** section shows wireless information such as Operating Mode, Frequency, and Channel. Since the AP/CPE supports multiple-SSIDs, information about each SSID, the ESSID, and security settings, are displayed

**Note:** Profile Settings are only applicable in Access Point and WDS AP modes.

Wireless LAN Information - 5GHz				
Operation Mode	AP			
Wireless Mode	802.11a/n			
Channel Bandwidth	40 MHz			
Channel	5.86 GHz (Channel 130)			
Distance	1000 M			
Profile	SSID	Security	VID	802.1Q
41	EnGenius063C97_1-5GHz	None	51	Disable
42	EnGenius063C97_2-5GHz	None	52	Disable
43	EnGenius063C97_3-5GHz	None	53	Disable
44	EnGenius063C97_4-5GHz	None	54	Disable
45	EnGenius063C97_5-5GHz	None	55	Disable
46	EnGenius063C97_6-5GHz	None	56	Disable
47	EnGenius063C97_7-5GHz	None	57	Disable
48	EnGenius063C97_8-5GHz	None	58	Disable

- The **Statistics** section shows Mac information such as SSID, MAC address, RX and TX.

Statistics				
	SSID	MAC	RX(Packets)	TX(Packets)
Ethernet		00:02:6F:FF:FF:FF	75.57KB(356 PKts.)	455.92KB(399 PKts.)
EnGenius063C96_1-2.4GHz		88:DC:96:06:3C:96	0KB(0 PKts.)	0.750KB(4 PKts.)
EnGenius063C97_1-5GHz		68:DC:96:06:3C:97	0KB(0 PKts.)	0KB(0 PKts.)

# Connection

## 5 GHz Connection List

Click the connection link under the Overview menu displays the connection list of clients associated to the AP/CPE's 5 GHz, along with the MAC addresses and signal strength for each client. Clicking **Refresh** updates the client list.

**Note:** Only applicable in Access Point and WDS AP modes.

## WDS Link List

Click the connection link under the Overview menu. This page displays the current status of the WDS link, including WDS Link ID, MAC Address, Link Status and RSSI.

**Note:** Only applicable in WDS AP and WDS Bridge modes.



# Realtime

The Realtime section contains the following options:

**CPU Loading:** 3 minutes CPU loading percentage information, it displays current loading, average loading and peak loading status. Left bar is loading percentage; button is time tracing. Interval is every 3 seconds

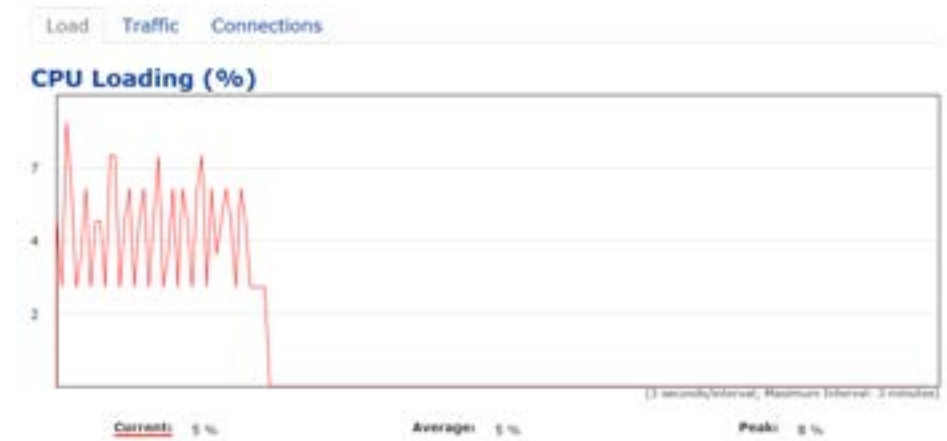

**Traffic Loading:** 5GHz and Ethernet port inbound and outbound traffic by current, average and peak time.



**Realtime Connection (Pkts):** Overview on current active network connections. It displays UDP and TCP packets information and other connection status. UDP connections curve is in blue; TCP connection curve is in green; others curve is in red. Below of chart shows connections source and destination.

# Chapter 6

# **Network**



# Basic IP Settings

## IPv4/IPv6 Settings

This page allows you to modify the device's IP settings.

IPv4 Settings	
IP Network Setting	Static IP
IP Address	192.168.1.1
Subnet Mask	255.255.255.0
Gateway	192.168.1.1
Primary DNS	0.0.0.0
Secondary DNS	0.0.0.0

IPv6 Settings	
IP Address	<input type="checkbox"/> Link-local Address
Subnet Prefix Length	
Gateway	
Primary DNS	
Secondary DNS	

**IP Network Settings:** Select whether the device IP address will use a static IP address specified in the IP address field or be obtained automatically when the device connects to a DHCP server.

**IP Address:** The IP address of this device.

**Subnet Mask:** The IP Subnet mask of this device.

**Gateway:** The Default Gateway of this device. Leave it blank if you are unsure of this setting.

**Primary/Secondary DNS:** The primary/secondary DNS address for this device.

**Save:** Click **Save** to confirm the changes.

## Spanning Tree Protocol (STP) Settings

This page allows you to modify the Spanning Tree settings. Enabling the Spanning Tree protocol will prevent network loops in your LAN network.

Spanning Tree Protocol (STP) Settings		
Status	Disable	
Hello Time	2	seconds (1-10)
Max Age	20	seconds (6-40)
Forward Delay	4	seconds (4-30)
Priority	32768	(0-65535)

**Spanning Tree Status:** Enables or disables the Spanning Tree function.

**Hello Time:** Specifies Bridge Hello Time in seconds. This value determines how often the device sends handshake packets to communicate information about the topology throughout the entire Bridged Local Area Network.

**Max Age:** Specifies Bridge Max Age in seconds. If another bridge in the spanning tree does not send a hello packet for a long period of time, it is assumed to be inactive.

**Forward Delay:** Specifies Bridge Forward Delay in seconds. Forwarding delay time is the time spent in each of the Listening and Learning states before the Forwarding state is entered. This delay is provided so that when a new bridge comes onto a busy network, it analyzes data traffic before participating in the network.

**Priority:** Specifies the Priority Number. A smaller number has a greater priority than a larger number.

**Save:** Click **Save** to confirm the changes.

# Chapter 7

# **Wireless**





# Wireless

## Wireless Settings

Wireless Settings	
Device Name	EnStation5-AC
Country / Region	Canada

\*The model name will be varied by different models.

**Device Name:** Enter a name for the device. The name you type appears in SNMP management. This name is not the SSID and is not broadcast to other devices.

**Save:** Click **Save** to confirm the changes.

## EnJet

The AP/CPE is default EnJet enable. When enable the EnGenius EnJet system, the AP/CPE can then transmit data more efficiently, avoid collisions, and reduce latency and packet losses. (If you do not enable EnJet, data will be sent via traditional CSMA.)

EnJet	
<input type="radio"/> Disable	<input checked="" type="radio"/> Enable

This page displays the current status of the Wireless settings of the AP/CPE.

## Wireless Network

### EnStation5-ACv2/ENS500-ACv2/ENS500EXT-ACv2

**Wireless:** The AP/CPE supports 802.11ac/n mixed mode in

5GHz -802.11 AC/N

Operation Mode	Access Point ▼	<input checked="" type="checkbox"/> Green
Channel HT Mode	40MHz ▼	
Channel	Configuration	
Transmit Power	Auto ▼	
Bit Rate	Configuration	
Client Limits	127	<input checked="" type="checkbox"/> Enable <input type="checkbox"/> Disable
AP Detection	Scan	
Distance (0-30km)	1	(0.6miles)
AP Time Slot	Auto ▼	
Station Priority	High ▼	

**Operation Mode:** Select **Operation Mode**. When Enjet enable, The AP/CPE can be seted as Access Point, Client Bridge or WDS (AP & Station) or Access Point, Client Bridge or WDS (AP, Station & Bridge) when Enjet disable.

**Channel HT Mode:** The default channel bandwidth is 20 MHz/ 40 /80 MHz. The larger the channel, the greater the transmission quality and speed.

**Channel:** Click Configuration button to open a new windows to configure channels for performing wireless service.

5GHz

Auto	None
U-NII-1	U-NII-2A
U-NII-2B	U-NII-3
Ch 36 : 5.180 GHz	Ch 40 : 5.200 GHz
Ch 44 : 5.220 GHz	Ch 48 : 5.240 GHz
Ch 52 : 5.260 GHz	Ch 56 : 5.280 GHz
Ch 60 : 5.300 GHz	Ch 64 : 5.320 GHz
Ch100 : 5.500 GHz	Ch104 : 5.520 GHz
Ch108 : 5.540 GHz	Ch112 : 5.560 GHz
Ch132 : 5.660 GHz	Ch136 : 5.680 GHz
Ch149 : 5.745 GHz	Ch153 : 5.765 GHz
Ch157 : 5.785 GHz	Ch161 : 5.805 GHz

**Transmit Power:** Sets the power output of the wireless signal.

**Bit Rate:** 5GHz is default 6 Mbps, the range can control by BAR via scroll from 6Mbps to 54Mbps.

**Client Limits:** When Enjet enable, limits the total number of clients. Once setting the ceiling of client numbers, the maximum associated client devices will be restricted at this number.

**AP Detection:** AP Detection can select the best channel to

use by scanning nearby areas for Access Points.

**Distance:** Specifies the distance between Access Points and client devices. The proper setting for this parameter may assist Access Points to avoid the improper operation when transmitting data under a filed application.

**AP Time Slot:**In Enjet mode, the AP will assign time slots for each client’s data transmission. The larger the slot, the faster the data transmission.

**Station Priority:**In Enjet mode, the client bridge/WDS station’s data transmission is prioritized by data. High level means a longer transmission time. (The time ratio is 10:5:1.)

## Wireless Setting-5GHz

**Current Profile:** You can configure up to seven(7)different SSIDs when Enjet disable or 1 SSID when Enjet enable. If multiple client devices will be accessing the network, you can arrange the devices into SSID groups. Click **Edit** to configure the profile and check whether you want to enable extra SSID.

Wireless Settings - 5GHz

No.	Enable	SSID	Edit	Security	Suppressed SSID	Station Separation	Isolation	VID
1	<input checked="" type="checkbox"/>	EnGenius063C97_1-5GHz	Edit	None	<input type="checkbox"/>	<input type="checkbox"/>	<input type="checkbox"/>	51
2	<input type="checkbox"/>	EnGenius063C97_2-5GHz	Edit	None	<input type="checkbox"/>	<input type="checkbox"/>	<input type="checkbox"/>	52
3	<input type="checkbox"/>	EnGenius063C97_3-5GHz	Edit	None	<input type="checkbox"/>	<input type="checkbox"/>	<input type="checkbox"/>	53
4	<input type="checkbox"/>	EnGenius063C97_4-5GHz	Edit	None	<input type="checkbox"/>	<input type="checkbox"/>	<input type="checkbox"/>	54
5	<input type="checkbox"/>	EnGenius063C97_5-5GHz	Edit	None	<input type="checkbox"/>	<input type="checkbox"/>	<input type="checkbox"/>	55
6	<input type="checkbox"/>	EnGenius063C97_6-5GHz	Edit	None	<input type="checkbox"/>	<input type="checkbox"/>	<input type="checkbox"/>	56
7	<input type="checkbox"/>	EnGenius063C97_7-5GHz	Edit	None	<input type="checkbox"/>	<input type="checkbox"/>	<input type="checkbox"/>	57

SS Wireless Settings - 5GHz

Purpose	SSID	Edit	Security	Hidden SSID	Client Isolation	VLAN Isolation	L2 Isolation	VLAN ID
TDMA	EnGenius70905D_1-5GHz	Edit	None	<input type="checkbox"/>	<input type="checkbox"/>	<input type="checkbox"/>	<input type="checkbox"/>	51

**Management Interface:** This Management interface make you can to get on and change the configuration of the

Management interface

Purpose	SSID	Edit	Security	Hidden SSID	Client Isolation	VLAN Isolation	L2 Isolation	VLAN ID
w	EnJat70905D	Edit	WPA2/PSK AES	<input type="checkbox"/>	<input checked="" type="checkbox"/>	<input checked="" type="checkbox"/>	<input type="checkbox"/>	58

**Enable:** Click this check box to enable this SSID interface. The default SSIDs are enable on the first 5GHz SSID.

**SSID:** Specifies the SSID for the current profile.

**Hidden SSID:** Check this option to hide the SSID from clients. If checked, the SSID will not appear in the site survey.

**Client Isolation:** Click the appropriate radio button to enable this function for allowing or preventing communication between client devices.

**VLAN Isolation:** Restrict clients communicating with different VLANs by selecting the radio button.

**L2 Isolation:** Enable this function prevent client devices to communicate on the both WLAN and LAN.

**VLAN ID:** Specifies the VLAN tag for each profile. If your network includes VLANs, you can specify a VLAN ID for packets pass through the Access Point with a tag.

**Wireless Security:** See the Wireless Security section.

**Save:** Click **Save** to accept the changes.

## Wireless Security

The *Wireless Security* section lets you configure the AP's security modes

Wireless Security - 5GHz	
Security Mode	WPA-PSK ▼
Encryption	AES ▼
Passphrase	<input type="text"/>
Group Key Update Interval	3600

**Security Mode:** Including WPA2-PSK, WPA2-Enterprise. We strongly recommend you to use WPA2-PSK mode.

Wireless Security	
Security Mode	WPA2-Enterprise ▼
Encryption	AES ▼
Group Key Update Interval	3600 (30~3600; 0:Disable)
Radius Server	192.168.100.38
Radius Port	1812
Radius Secret	1234567890123456789012345

**Encryption:** Default is AES. Please ensure that your wireless clients use the same settings.

**Group Key Update Interval:** Specifies how often, in

seconds, the Group Key changes. The default value is 3600

**Radius Server:** Enter the IP address of the Radius server.

**Radius Port:** Enter the port number used for connections to the Radius server.

**Radius Secret:** Enter the secret required to connect to the Radius server.

## Radius Settings

**NAS-ID:** Enable or disable accounting feature.

**NAS-Port:** Enable or disable accounting feature.

**NAS-IP:** Enable or disable accounting feature.

## Radius Accounting

**Radius Accounting:** Enable or disable accounting feature.

**Radius Accounting Server:** Enter the IP address of the Radius accounting server.

**Radius Accounting Port** Enter the port number used for connections to the Radius accounting server.

**Radius Accounting Secret:** Enter the secret required to connect to the Radius accounting server.

**Interim Accounting Interval:** Specifies how often, in seconds, the accounting data sends.

**Note:** 802.11n does not allow WPA2-PSK TKIP security mode. The connection mode will automatically change from 802.11n to 802.11g.

## Fast Roaming

Enable the function to serve mobile client devices that roam from Access Point to Access Point. Some applications running on Client devices require fast re-association when they roam to a different Access Point



Please enter the settings of the SSID and initialize the Security mode to WPA2 enterprise, as well as to set the Radius Server firstly. Users can enable the Fast Roaming and implement the advanced search.

Please also set the same enterprise Encryption under the same SSID on other Access Points and enable the Fast Roaming. When the configuration is realized on different Access Point, the mobile client devices can run the voice service and require seamless roaming to prevent delay in conversation from Access Point to Access Point.

## Wireless MAC Filtering

Wireless MAC Filtering is used to allow or deny network access to wireless clients (computers, tablet PCs, NAS, smartphones, etc.) according to their MAC addresses. You can manually add a MAC address to restrict permission to access the AP/CPE. The default setting is: **Disable Wireless MAC Filter**.

**Note:** Only applicable in Access Point and WDS AP modes.



The screenshot shows the 'Wireless MAC Filter' configuration interface. At the top, the title 'Wireless MAC Filter' is displayed. Below it, the 'ACL Mode' is set to 'Disabled' in a dropdown menu. To the right of the dropdown is an 'Add' button. Below the 'Add' button is a table with two columns: '#' and 'MAC Address'. The table is currently empty.

**ACL Mode:** Determines whether network access is granted or denied to clients whose MAC addresses appear in the MAC address table on this page. Your choices are: Disabled, Deny MAC in the list, or Allow MAC in the list.

**MAC Address:** Enter the MAC address of the wireless client.

**Add:** Click **Add** to add the MAC address to the MAC address table.

**Delete:** Delete the selected entries.

**Save:** Click **Save** to apply the changes.

## Wireless Traffic Shaping

Traffic shaping regulates the flow of packets leaving an interface to deliver improved Quality of Service. The function will allow administrators to restrict the wireless bandwidth per SSID.

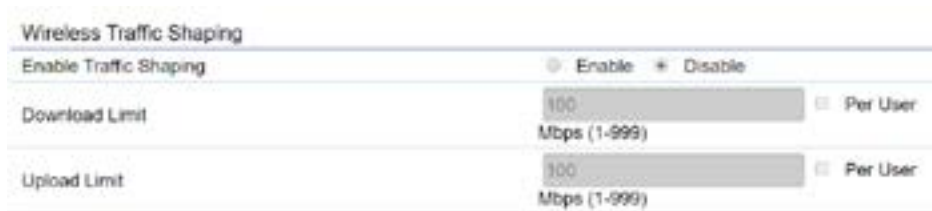

The screenshot shows a configuration page titled "Wireless Traffic Shaping". It features a section for "Enable Traffic Shaping" with radio buttons for "Enable" (selected) and "Disable". Below this are two rows for bandwidth limits: "Download Limit" and "Upload Limit". Each row has a text input field containing "100", a unit dropdown menu set to "Mbps (1-999)", and a "Per User" checkbox which is checked.

Wireless Traffic Shaping		
Enable Traffic Shaping	<input checked="" type="radio"/> Enable <input type="radio"/> Disable	
Download Limit	<input type="text" value="100"/> <input type="text" value="Mbps (1-999)"/>	<input checked="" type="checkbox"/> Per User
Upload Limit	<input type="text" value="100"/> <input type="text" value="Mbps (1-999)"/>	<input checked="" type="checkbox"/> Per User

**Enable Traffic Shaping:** Check this option to enable Wireless Traffic Shaping.

**Download Limit:** Specifies the wireless transmission bandwidth used for downloading.

**Upload Limit:** Specifies the wireless transmission bandwidth used for uploading.

**Save:** Click **Save** to confirm the changes.



## Guest Network Settings

Adding a guest network when EnJet disable allows visitors to use the Internet without giving out your office or company wireless security key. You can add a guest network to each wireless network in the 5 GHz ac/a/n



The screenshot shows the 'Guest Network Settings' interface. It includes a table with columns for 'Enable', 'SSID', 'Edit', 'Security', 'Hidden SSID', and 'Client Isolation'. Below the table, there are sections for 'Manual IP Settings' and 'Automatic DHCP Server Settings'. The 'Manual IP Settings' section includes fields for IP Address (192.168.200.1) and Subnet Mask (255.255.255.0). The 'Automatic DHCP Server Settings' section includes fields for Starting IP Address (192.168.200.100), Ending IP Address (192.168.200.200), and WINS Server IP (0.0.0.0).

**SSID:** Specifies the SSID for the current profile.

**Suppressed SSID:** Check this option to hide the SSID from clients. If checked, the SSID will not appear in the site survey.

**Station Separation:** Click the appropriate radio button to allow or prevent communication between client devices.

**IP Address:** The IP Address of this device.

**Subnet Mask:** The IP Subnet mask of this device.

**Starting IP Address:** The first IP Address in the range of

the addresses by the DHCP server.

**Ending IP Address:** The last IP Address in the range of addresses assigned by the DHCP server.

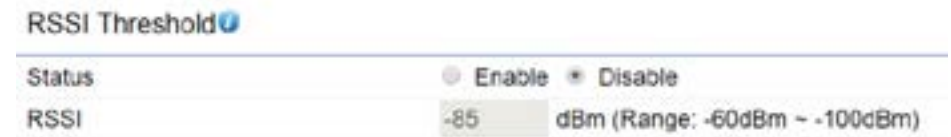

The screenshot shows the 'RSSI Threshold' settings. It includes a 'Status' section with radio buttons for 'Enable' and 'Disable'. Below that, there is a field for 'RSSI' with a value of '-85' and a label 'dBm (Range: -60dBm ~ -100dBm)'. The 'Disable' radio button is selected.

**RSSI Threshold:** Enable the Fast Handover feature when EnJet disable by ensuring that each client is served by at least one Access Point at any time. Access Points continuously monitor the connectivity quality of any client in their range and efficiently share this information with other Access Points in the vicinity of that client to coordinate which of them should serve the client best.

**RSSI:** Enter the RSSI (Received Signal Strength Index) in order to determine the handover procedure which the current wireless link will terminate. RSSI is an indication of the power level being received by the antenna. Therefore, the higher the RSSI number, the stronger the signal.

## Management VLAN Settings

This page allows you to assign a VLAN tag to packets sent over the network. A VLAN is a group of computers on a network whose software has been configured so that they behave as if they were on a separate Local Area Network (LAN). Computers on VLAN do not have to be physically located next to one another on the LAN.

**Note:** Only applicable in Access Point and WDS AP modes.

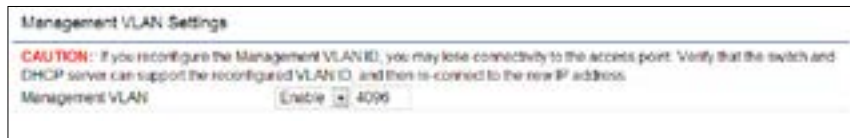

Management VLAN Settings

**CAUTION:** If you reconfigure the Management VLAN ID, you may lose connectivity to the access point. Verify that the switch and DHCP server can support the reconfigured VLAN ID, and then is connected to the new IP address.

Management VLAN  Enable

**Management VLAN:** If your network includes VLANs, you can enable **Management VLAN ID** for packets passing through the Access Point with a tag.

**Save:** Click **Save** to confirm the changes or **Cancel** to cancel and return to previous settings.

**Note:** If you reconfigure the Management VLAN ID, you may lose your connection to the EnStationAC. Verify that the DHCP server supports the reconfigured VLAN ID and then reconnect to the EnStationAC using the new IP address.

# Chapter 8

# Management



# Advanced Settings

## SNMP Settings

This page allows you to assign the Contact Details, Location, Community Name, and Trap Settings for a Simple Network Management Protocol (SNMP). SNMP is a networking management protocol used to monitor network attached devices. SNMP allows messages (called protocol data units) to be sent to various parts of the network. Upon receiving these messages, SNMP compatible devices (called agents) returns the data stored in their Management Information Bases.

SNMP Settings	
Status	Enable
Contact	
Location	
Port	161
Community Name (Read Only)	public
Community Name (Read Write)	private
Trap Destination	
- Port	162
- IP Address	
- Community Name	public
SNMPv3 Settings	
- Status	Enable
- Username	admin (1-31 Characters)
- Authorized Protocol	MDS
- Authorized Key	12345678 (8-32 Characters)
- Private Protocol	DES
- Private Key	12345678 (8-32 Characters)
- Engine ID	

**SNMP Enable/Disable:** Enables or disables the SNMP feature.

**Contact:** Specifies the contact details of the device.

**Location:** Specifies the location of the device.

**Community Name (Read Only):** Specifies the password for the SNMP community for read only access.

**Community Name (Read/Write):** Specifies the password for the SNMP community with read/write access.

**Trap Destination Address:** Specifies the IP address of the computer that will receive the SNMP traps.

**Trap Destination Community Name:** Specifies the password for the SNMP trap community.

**SNMPv3:** Enables or disables the SNMPv3 feature.

**User Name:** Specifies the username for SNMPv3.

**Auth Protocol:** Selects the authentication protocol type: MDS or SHA.

**Auth Key:** Specifies the authentication key.

**Priv Protocol:** Selects the privacy protocol type: DES.

**Priv Key:** Specifies the privacy key for privacy.

**Engine ID:** Specifies the engine ID for SNMPv3.

**Apply Save:** Click **Apply Save** to apply the changes.

## CLI Settings



The screenshot shows a configuration page with three sections: CLI Setting, SSH Setting, and HTTPS Setting. Each section has a label and a dropdown menu. The CLI dropdown is set to 'Enable', the SSH dropdown is set to 'Disable', and the HTTPS dropdown is set to 'Enable'. Below the HTTPS dropdown, there is a label 'HTTPS forward' with a dropdown menu set to 'Disable'.

**CLI:** The Command Line Interface (CLI) allows you to type commands instead of choosing them from a menu or selecting an icon.

**SSH:** Enable Secure Shell (SSH) to make secure, encrypted connections in the network. Secure Shell is a network protocol that allows data to be exchanged using a secure channel between two network devices.

**HTTPS:** Enable HTTPS to transfer and display web content securely. The Hypertext Transfer Protocol over SSL (Secure Socket Layer) is a TCP/IP protocol used by web servers to transfer and display web content securely.

## Email Alert

You can use the Email Alert feature to send messages to the configured email address when particular system events occur.

Note: Do **NOT** use your personal email address as it can unnecessarily expose your personal email login credentials. Use a separate email account made for this feature instead

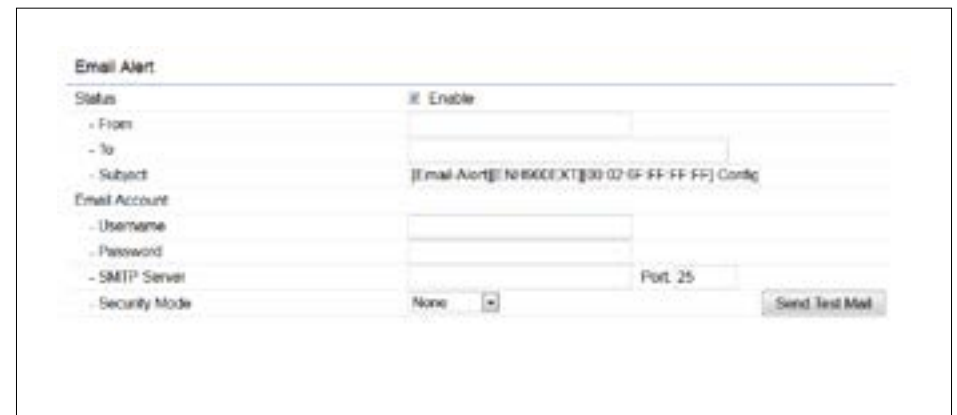

The screenshot shows an 'Email Alert' configuration page. It has a 'Status' dropdown set to 'Enable'. Below it are fields for 'From', 'To', and 'Subject'. The 'Subject' field contains the text '[Email Alert]: [Hexadecimal IP Address] Config'. Underneath is an 'Email Account' section with fields for 'Username', 'Password', and 'SMTP Server' (set to 'Port. 25'). There is also a 'Security Mode' dropdown set to 'None' and a 'Send Test Mail' button.

**From:** Enter the email address to show the sender of the email.

**To:** Enter the address that you wish to send emails to.

**Subject:** Enter the text that you wish to appear in the email's subject line.

**Username:** Enter the username for the email account that will be used to send emails.

**Password:** Enter the password for the email account that will be used to send emails.

**SMTP Server:** Enter the IP address or hostname of the outgoing SMTP server.

**Port:** Enter the SMTP port number to use for outbound emails.

**Security Mode:** Selects the security mode: SSL/TLS or STARTTLS or None.

**Apply:** To save setting and take effect.

# Time Zone

## Time Setting

This page allows you to set the internal clock of the EnStationAC.

The screenshot shows two sections of a configuration page. The top section, titled "Date and Time Settings", has two radio buttons. The first, "Manually Set Date and Time", is selected and shows input fields for "Date" (2013 / 08 / 25) and "Time" (08 : 10 (24-Hour)), along with a "Synchronize with PC" button. The second radio button, "Automatically Get Date and Time", is unselected and shows an "NTP Server" field with the value "209.81.9.7". The bottom section, titled "Time Zone", shows a dropdown menu for "Time Zone" set to "UTC+00:00 Gambia, Liberia, Morocco". Below it is a checkbox for "Enable Daylight Saving" which is checked. Underneath are two rows of dropdown menus for "Start" and "End", both currently set to "January", "1st", and "12 am".

**Start:** Select the day, month, and time when daylight savings time starts.

**End:** Select the day, month, and time when daylight savings times ends.

**Manually Set Date and Time:** Manually specify the date and time.

**Automatically Get Date and Time:** Select and check whether you wish to enter the IP address of an NTP server or use the default NTP server to have the internal clock set automatically.

**Enable Daylight Saving:** Check whether daylight savings applies to your area.

# Auto Reboot Settings

You can specify how often you wish to reboot the EnStationAC.



The screenshot shows a configuration window titled "Auto Reboot Setting". It contains the following elements:

- Auto Reboot Status:** A dropdown menu currently set to "Disable".
- Timer:** A row of checkboxes for each day of the week: Sunday, Monday, Tuesday, Wednesday, Thursday, Friday, and Saturday. All checkboxes are currently unchecked.
- Time Input:** Two input fields for time, both containing the number "0".

**Auto Reboot Setting:** Enables or disables the Auto Reboot function.

**Frequency of Auto Reboot:** Specifies how often you wish to reboot the EnStationAC by Min, Hour, Day or Week.

**Timer:** Select the day and enter the time you would like to reboot automatically.

**Save:** Click **Save** to apply the changes.



# Wi-Fi Scheduler

The Wi-Fi Scheduler can be created for use in enforcing rules. For example, if you wish to restrict web access to Mon-Fri from 3pm to 8pm, you could create a schedule selecting Mon, Tue, Wed, Thu and Fri while entering a Start time of 3pm and End Time of 8pm to limit access to these times.

Day	Availability	Duration
Sunday	available	00 : 00 ~ 24 : 00
Monday	available	00 : 00 ~ 24 : 00
Tuesday	available	00 : 00 ~ 24 : 00
Wednesday	available	00 : 00 ~ 24 : 00
Thursday	available	00 : 00 ~ 24 : 00
Friday	available	00 : 00 ~ 24 : 00
Saturday	available	00 : 00 ~ 24 : 00

**Status:** Enables or disables the Wi-Fi scheduler function.

**Wireless Radio:** Select 2.4 GHz or 5 GHz from the drop-down list for the preferred band type.

**SSID Selection:** Select a SSID from the drop-down list.

**Schedule Templates:** Select a schedule template from the

drop-down list.

**Day(s):** Place a checkmark in the boxes for the desired days or select the **All Week** radio button to select all seven days of the week.

**Duration:** The Start Time is entered in two fields. The first box is for hours and the second box is for minutes. The End Time is entered in the same format as the Start time.

# Tools

## Ping Test Parameters

This page allows you to analyze the connection quality of the EnStationAC and trace the routing table to a target in the network.

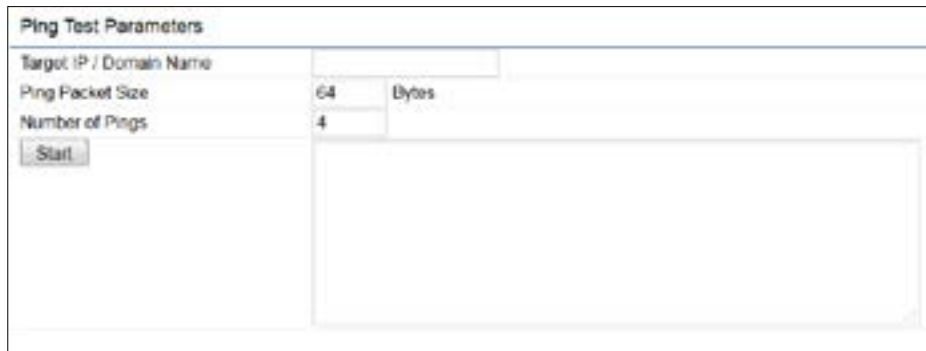

The screenshot shows a web form titled "Ping Test Parameters". It has a text input field for "Target IP / Domain Name". Below it are two rows: "Ping Packet Size" with a value of "64" and a unit of "Bytes", and "Number of Pings" with a value of "4". At the bottom left is a "Start" button.

**Target IP:** Enter the IP address you would like to search.

**Ping Packet Size:** Enter the packet size of each ping.

**Number of Pings:** Enter the number of times you wish to ping.

## Traceroute Test Parameter



The screenshot shows a web form titled "Traceroute Test Parameters". It has a text input field for "Target IP / Domain Name". Below it are two buttons: "Start" and "Stop".

**Target IP:** Enter the IP address you would like to trace

## Nslookup Test Parameter

**Target IP/Domain Name:** Enter the IP address or domain name you wish to do Nslookup test.

## Speed Test Parameters



The screenshot shows a web form titled "Speed Test Parameters". It has a text input field for "Target IP / Domain Name". Below it are four rows: "Time Period" with a value of "20" and a unit of "Sec", "Check Interval" with a value of "5" and a unit of "Sec", "IPv4Port" with a value of "5001", and "IPv6Port" with a value of "5002". At the bottom left is a "Start" button.

**Target IP / Domain Name:** Enter an IP address or domain name you wish to implement a speed test for realizing the variance on wireless speed.

**Time Period:** Enter the time in seconds that you would like the test to implement for and in how many intervals.

**IPv4/IPv6 Port:** This Access Points uses IPv4 5001 and IPv6 60001 port for the speed test.

**Start:** Click start to implement speed test.

## Device Discovery

This page allows you to discover devices from network for Operation Mode, IP Address, System MAC Address and Firmware version.

Device Discovery				
Device Name	Operation Mode	IP Address	System MAC Address	Firmware Version
<input type="button" value="Scan"/>				

# Account

This page allows you to change the EnStationAC username and password. By default, the username is: **admin** and the password is: **admin**. The password can contain from 0 to 12 alphanumeric characters and is case sensitive.

## Account Settings



Account Settings	
Administrator Username	admin
Current Password	
New Password	
Verify Password	

Apply saved settings to take effect

**Administrator Username:** Enter a new username for logging in to the New Name entry box.

**Current Password:** Enter the old password for logging in to the Old Password entry box.

**New Password:** Enter the new password for logging in to the New Password entry box.

**Verify Password:** Re-enter the new password in the Confirm Password entry box for confirmation.

**Apply:** Click **Apply** to apply the changes.

# Firmware

## Firmware Upgrade

This page allows you to upgrade the firmware of the EnStationAC.



Firmware Upgrade

Current Firmware Version: 2.0.0

Select the new firmware from your hard disk.

No file selected

### To Perform the Firmware Upgrade:

1. Click the **Choose File** button and navigate the OS file system to the location of the upgrade file.
2. Select the upgrade file. The name of the file will appear in the Upgrade File field.
3. Click the **Upload** button to commence the firmware upgrade.

**Note:** The device is unavailable during the Firmware upgrade process and must restart when the upgrade is completed. Any connections to or through the device will be lost.

# Backup/Restore

## Backup/Restore

This page allows you to save the current device configurations. When you save your configurations, you also can reload the saved configurations into the device through the Restore Saved Settings from a file section. If extreme problems occur, or if you have set the AP incorrectly, you can use the **Reset** button in the Revert to Factory Default Settings section to restore all the configurations of the AP to the original default settings.

**Backup Setting:** Click **Export** to save the current configured settings.

**Restore New Setting:** To restore settings that have been previously backed up, click **Browse**, select the file, and click **Restore**.

**Restore to Default:** Click **Reset** button to restore the AP to its factory default settings.

**Backup/Restore Settings**

---

Factory Setting

- Backup Setting ⓘ
- Restore New Setting
- Reset to Default ⓘ

User Setting

- Back Up Setting as Default
- Restore to User Default ⓘ

- **Caution:** Please write down your account number and password before saving. The user settings will now become the new default settings at the next successful login.

## User Setting

The function allows you to backup the current device configurations into the EnStationAC as the default value. If extreme problems occur, or if you have set the EnStationAC incorrectly, you can push the Reset button to revert all the configurations of the EnStationAC to the user default.

**Back Up Setting as Default:** Click **Backup** to backup the user settings you would like to the device's memory for the default settings.

**Restore to User Default:** Click **Restore** to restore user settings to the factory standard settings.

**Note1:** After setting the current settings as the default, you should click the **Restore to Default** on the web interface for reverting the settings into the factory default instead of pushing the reset button.

**Note2:** Please **write down** your account and password before saving. The user settings will now become the new default settings at the next successful login.

# Log

## System Log

The EnStationAC automatically logs (records) events of possible interest in its internal memory. To view the logged information, click the **Log** link under the System Manager menu. If there is not enough internal memory to log all events, older events are deleted from the log. When powered down or rebooted, the log will be cleared.

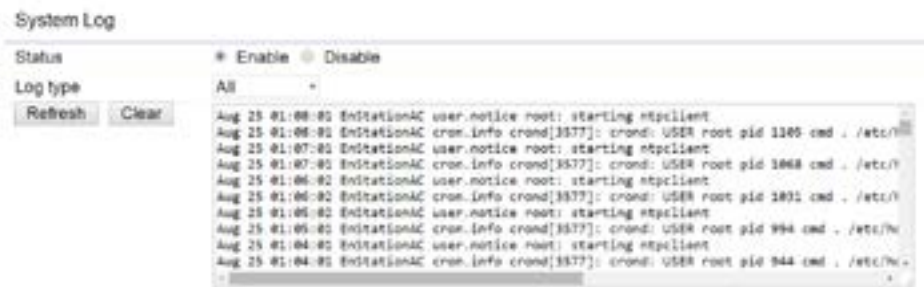

**Status:** Enable/Disable this function.

**Traffic Log:** Enable/Disable this function.

**Log type:** You may choose one of log types to display logs in the following window. The default log types is All.

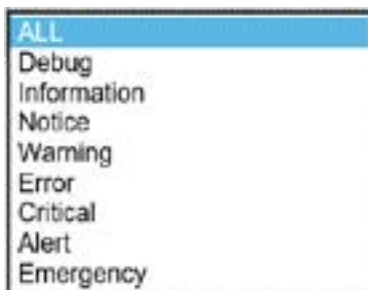

## Remote Log

This page allows you to setup the Remote Log functions for the AP/CPE.



**Syslog:** Enables or disables the syslog function.

**Log Server IP Address:** Enter the IP address of the log server.

**Remote Log: Enable** or disable the remote log service.

**Apply:** Click **Apply** to apply the changes.

## Logout

Click **Logout** in Management menu to logout.



\*The model name will be varied by different models.

Please confirm again to logout the system or not.



## Reset

In some circumstances, it may be required to force the device to reboot. Click on **Reset** to reboot or to reset the AP/CPE.



\*The model name will be varied by different models.

Once you click reset button, you will see the options for reboot or restore this AP.

Reboot the device: Click it to reboot this device.

Restore to Factory Default: Click it to reset this device to factory default setting.

Restore to User Default: Click it to reset this device to user default settings. For realizing the setting method, you may refer page 62.

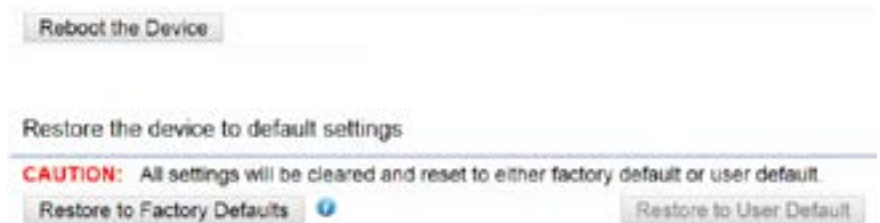



# Appendix



# Appendix A - FCC Interference Statement

## Federal Communication Commission Interference Statement

This device complies with Part 15 of the FCC Rules. Operation is subject to the following two conditions: (1) This device may not cause harmful interference, and (2) this device must accept any interference received, including interference that may cause undesired operation.

This equipment has been tested and found to comply with the limits for a Class B digital device, pursuant to Part 15 of the FCC Rules. These limits are designed to provide reasonable protection against harmful interference in a residential installation. This equipment generates, uses and can radiate radio frequency energy and, if not installed and used in accordance with the instructions, may cause harmful interference to radio communications. However, there is no guarantee that interference will not occur in a particular installation. If this equipment does cause harmful interference to radio or television reception, which can be determined by turning the equipment off and on, the user is encouraged to try to correct the interference by one of the following measures:

- Reorient or relocate the receiving antenna.
- Increase the separation between the equipment and receiver.
- Connect the equipment into an outlet on a circuit different from that to which the receiver is connected.
- Consult the dealer or an experienced radio/TV technician for help



### **FCC Caution:**

Any changes or modifications not expressly approved by the party responsible for compliance could void the user's authority to operate this equipment.

This transmitter must not be co-located or operating in conjunction with any other antenna or transmitter.

## **IMPORTANT NOTE: Radiation Exposure Statement**

This equipment complies with FCC radiation exposure limits set forth for an uncontrolled environment. This equipment should be installed and operated with a minimum distance of 25 cm between the radiator & your body.

# Appendix B - Professional Installation Instruction (FCC)

## Installation Personal

This product is designed for specific application and needs to be installed by a qualified personal who has RF and related rule knowledge. The general user shall not attempt to install or change the setting.

## Installation Location

The product shall be installed at a location where the radiating antenna can be kept 25cm from nearby person in normal operation condition to meet regulatory RF exposure requirement.

## External Antenna

Use only the antennas which have been approved by the applicant. The non-approved antenna(s) may produce unwanted spurious or excessive RF transmitting power which may lead to the violation of FCC limit and is prohibited.

## Installation Procedure

Please refer to user's manual for the detail.



### **Warning:**

Please carefully select the installation position and make sure that the final output power does not exceed the limit set force in relevant rules. The violation of the rule could lead to serious federal penalty.

# Appendix C - IC Interference Statement

## Industry Canada statement

This device complies with RSS-247 of the Industry Canada Rules. Operation is subject to the following two conditions: (1) This device may not cause harmful interference, and (2) this device must accept any interference received, including interference that may cause undesired operation.

Ce dispositif est conforme à la norme CNR-247 d'Industrie Canada applicable aux appareils radio exempts de licence. Son fonctionnement est sujet aux deux conditions suivantes: (1) le dispositif ne doit pas produire de brouillage préjudiciable, et (2) ce dispositif doit accepter tout brouillage reçu, y compris un brouillage susceptible de provoquer un fonctionnement indésirable.

### Caution:



- (i) the device for operation in the band 5150-5250 MHz is only for indoor use to reduce the potential for harmful interference to co-channel mobile satellite systems;
- (ii) high-power radars are allocated as primary users (i.e. priority users) of the bands 5250-5350 MHz and 5650-5850 MHz and that these radars could cause interference and/or damage to LE-LAN devices.
- (iii) Users should also be advised that high-power radars are allocated as primary users (i.e. priority users) of the bands 5650-5850 MHz and that these radars could cause interference and/or damage to LE-LAN devices.

### Avertissement:



- (i) les dispositifs fonctionnant dans la bande 5150-5250 MHz sont réservés uniquement pour une utilisation à l'intérieur afin de réduire les risques de brouillage préjudiciable aux systèmes de satellites mobiles utilisant les mêmes canaux;
- (ii) De plus, les utilisateurs devraient aussi être avisés que les utilisateurs de radars de haute puissance sont désignés utilisateurs principaux (c.-à-d., qu'ils ont la priorité) pour les bandes 5250-5350 MHz et 5650-5850 MHz et que ces radars pourraient causer du brouillage et/ou des dommages aux dispositifs LAN-EL.
- (iii) De plus, les utilisateurs devraient aussi être avisés que les utilisateurs de radars de haute puissance sont désignés utilisateurs principaux (c.-à-d., qu'ils ont la priorité) pour les bandes 5650-5850 MHz et que ces radars pourraient causer du brouillage et/ou des dommages aux dispositifs LAN-EL.

## Radiation Exposure Statement:

This equipment complies with ISED radiation exposure limits set forth for an uncontrolled environment. This equipment should be installed and operated with minimum distance 26cm between the radiator & your body.

## Déclaration d'exposition aux radiations:

Cet équipement est conforme aux limites d'exposition aux rayonnements ISED établies pour un environnement non contrôlé. Cet équipement doit être installé et utilisé avec un minimum de 20 cm de distance entre la source de rayonnement et votre corps.

## DETACHABLE ANTENNA USAGE

This radio transmitter (IC: A8J-ENSTA5-ACV2 / Model: EnStation5-ACv2, ENS500EXT-ACv2, ENS500-ACv2, EAS100-14, EAS100EXT, EAS100-19) has been approved by ISED to operate with the antenna type listed below with maximum permissible gain indicated. Antenna types not included in this list, having a gain greater than the maximum gain indicated for that type, are strictly prohibited for use with this device.

Le présent émetteur radio (IC: A8J-ENSTA5-ACV2/ Model: EnStation5-ACv2, ENS500EXT-ACv2, ENS500-ACv2, EAS100-14, EAS100EXT, EAS100-19) a été approuvé par ISED pour fonctionner avec les types d'antenne énumérés ci-dessous et ayant un gain admissible maximal. Les types d'antenne non inclus dans cette liste, et dont le gain est supérieur au gain maximal indiqué, sont strictement interdits pour l'exploitation de l'émetteur.

Approved antenna(s) list

No.	Type	Connector	Gain (dBi)			Remark
			Ant. 1 (5150-5850MHz)	Ant. 2 (5150-5850MHz)		
1	Patch	I-PEX	13.35	13.42	For Model: ENS500-ACv2 and EAS100-14 use only	
2	Dipole	RSMA	5.12	5.09	For Model: ENS500EXT-ACv2 and EAS100EXT use only	
			5.15	5.17		
3	Patch	I-PEX	15.5	15.5	For Model: EnStation5-ACv2 and EAS100-19 use only	

# Appendix D

## Professional installation instruction (IC)

### 1. Installation personal

This product is designed for specific application and needs to be installed by a qualified personal who has RF and related rule knowledge. The general user shall not attempt to install or change the setting.

### 2. Installation location

The product shall be installed at a location where the radiating antenna can be kept 26cm from nearby person in normal operation condition to meet regulatory RF exposure requirement.

### 3. External antenna

Use only the antennas which have been approved by the applicant. The non-approved antenna(s) may produce unwanted spurious or excessive RF transmitting power which may lead to the violation of ISED limit and is prohibited.

### 4. Installation procedure

Please refer to user's manual for the detail.

### 5. Warning

Please carefully select the installation position and make sure that the final output power does not exceed the limit set force in relevant rules. The violation of the rule could lead to serious federal penalty.

# Instructions d'installation professionnelle

## 1. Installation

Ce produit est destiné à un usage spécifique et doit être installé par un personnel qualifié maîtrisant les radiofréquences et les règles s'y rapportant. L'installation et les réglages ne doivent pas être modifiés par l'utilisateur final.

## 2. Emplacement d'installation

En usage normal, afin de respecter les exigences réglementaires concernant l'exposition aux radiofréquences, ce produit doit être installé de façon à respecter une distance de 26cm entre l'antenne émettrice et les personnes.

## 3. Antenne externe.

Utiliser uniquement les antennes approuvées par le fabricant. L'utilisation d'autres antennes peut conduire à un niveau de rayonnement essentiel ou non essentiel dépassant les niveaux limites définis par ISED, ce qui est interdit.

## 4. Procédure d'installation

Consulter le manuel d'utilisation.

## 5. Avertissement

Choisir avec soin la position d'installation et s'assurer que la puissance de sortie ne dépasse pas les limites en vigueur. La violation de cette règle peut conduire à de sérieuses pénalités fédérales.