

EnGenius®

# User Manual

Ultra-long range

**EnStation6/ENH500-AX**

# IMPORTANT

To install this Access Point please refer to the Quick Installation Guide included in the product packaging.

# Table of Contents

Chapter 1 Product Overview.....	4
Chapter 2 Before You Begin.....	12
Chapter 3 Configuring Your Access Point.....	24
Chapter 4 Building a Wireless Network. ....	27
Chapter 5 Status. ....	33
Chapter 6 Network.....	38
Chapter 7 Wireless. ....	41
Chapter 8 Management .....	52
Chapter 9 EnWiFi App .....	66
Appendix .....	79

Chapter 1

# **Product Overview**

## Key Features

- Supports IEEE802.11ax wireless standards
- Antennas
  - EnStation6: Internal 15.2dBi high gain directional antenna.
  - ENH500-AX: Internal 13.26dBi high gain directional antenna.
- Power Source
  - ENH500-AX Can be used with included 54V PoE adapter
  - EnStation6 Can be used with included 54V PoE adapter
- Device can be reset from remote PoE adapter
- Advanced 1024-QAM technology to achieve optimal performance throughout ultra-long distance



EnStation6



ENH500-AX

- In conjunction with 2.4GHz management interface and EnGenius EnWiFi App can help device configuration and monitoring more easily on smartphone or tablet.

## Introduction

The EnStation6/ENH500-AX is a high-powered, ultra long-range 2x2 Wireless 802.11ax/ac/a/n Outdoor Access Point with speeds up to 1184 Mbps on both its high-powered 5 GHz radios. It can be configured as an:

Access Point, Client Bridge or WDS (AP, Station & Bridge) . The EnStation6/ENH500-AX is designed to operate in a variety of outdoor environments. Its high- powered, long-range characteristics make it a cost effective alternative to **ordinary Access Points that don't have the** range and reach to connect to a growing number of wireless CPEs who wish to connect to a business network. The EnStation6/ENH500-AX supports the 5 GHz frequency band for communicating to other 5GHz frequency bands Access Points concurrently. Several EnStation6/ENH500-AX can be networked in a campus setting using the 5 GHz band between countries, which is easy to be installed in virtually any location with its included PoE (Power over Ethernet) Adapter for quick outdoor installation. It also supports wireless encryption including Wi-Fi Protected Access (WPA2-PSK) Encryption and IEEE 802.1AX with RADIUS.)

## System Requirements

The following are the Minimum System Requirements in order to configure the device.

- Computer with an Ethernet interface or wireless network capability
- Windows OS (XP, Vista, 7, 8, 10), Mac OS, or Linux-based operating systems
- Web-Browsing Application (i.e.: Internet Explorer, Firefox, Safari, or another similar browser application)

## Package Contents

The EnStation6 package contains the following items: \*

- EnStation6 Customer Premises Equipment
- EnStation6 with PoE Adapter EPA5006GR
- Power Cord
- Pole Mount Strap
- Wall Mount Bracket Base
- Screw Sets Kit
- Sealing Nut
- Dynamic Stick
- Quick Installation Guide

\*(all items must be in package to issue a refund):

The ENH500-AX package contains the following items: \*

- ENH500-AX
- PoE Adapter (EPA5006GR)
- Power Cord
- Pole Mount Strap
- Wall Mount Screw Set
- Quick Installation Guide

\*(all items must be in package to issue a refund):

# Technical Specifications

## Standard

IEEE802.11ax/ac/a/n on 5 GHz

## Antenna

EnStation6: Internal 15.2dBi high gain directional antenna.

ENH500-AX: Internal 13.26dBi high gain directional antenna

## Physical Interface

2 x 10/100/1000 Gigabit Ethernet Port with PoE support

LAN(PoE) Port supports 54V PoE Input

## LED Indicator

Power

LAN 1

LAN 2

WLAN

WLAN LED (Weak, Medium, Strong)

## Power Requirements

ENH500-AX Include PoE Adapter, 54V 0.6A

EnStation6 Include PoE Adapter, 54V 0.6A

## Optimal Performance

Distance Control (Ack Timeout)

Multicast Supported

Data Rate Selection

Auto Channel Selection

BSSID Support

AP Time Slot

Station Priority

## Easily Management

VLAN Tag / VLAN Pass-through

Guest Network

QoS: Complaint with IEEE 802.11e /WMM

RADIUS Accounting

Wireless STA (Client) connection list

Traffic Shaping (Per SSID)

## Intuitive Tools

SNMP v1/v2c/v3 support

MIB I/II, Private MIB

Save Configuration as Default

CLI Support

WiFi-Scheduler/Auto Reboot

E-mail Alert



## Reinforcement Security

WPA2 Enterprise

Hide SSID in beacons

MAC address filtering, up to 32 MACs per SSID

Wireless STA (Client) connection list

Https Support

SSH Support

## QoS (Quality of Service)

Compliant with IEEE 802.11e standard

## Physical/Environment Conditions

Operating:

Temperature: -20 °C to 60 °C (-4 °F to 140 °F)

Humidity (non-condensing): 90% or less

Storage:

Temperature: -30 °C to 80 °C (-22 °F to 176 °F )

Humidity (non-condensing): 90% or less

# Physical Interface - EnStation6

## Dimensions and Weights

EnStation6

Dimension: 190mm (7.48")

**Height: 38mm (1.9")**

Weight: 527g (1.16 lbs)

- 1 WLAN Signal LED: Applied on Client Bridge/WDS
  - (1) Red: Weak Signal: Connecting quality is bad.
  - (2) Yellow: Connecting quality is Normal.
  - (3) Green: Connection quality is Good.
- 2 LAN(PoE) Signal LED
- 3 LAN Signal LED of the 2nd Port
- 4 Power Signal:
- 5 LAN Port 1: Gigabit Ethernet port for RJ-45 cable.
- 6 LAN Port 2: Gigabit Ethernet port for RJ-45 cable.



# Physical Interface – ENH500-AX

## Dimensions

Length: 260mm (10.24")

Width: 84 (3.31")

Depth: 55mm (2.17")

- 1 LAN Port 1 (Proprietary 54V PoE): Ethernet port for RJ-45 cable.
- 2 LAN Port 2 : Ethernet port for RJ-45 cable.
- 3 Reset Button

\*The installation angle of antenna must be vertical to the ground.



Chapter 2

# **Before You Begin**

# Computer Settings

Windows XP/Windows 7/Windows 8/Windows 10

In order to use the Access Point, you must first configure the TCP/IPv4 connection of your Windows OS computer system.

1a. Click the Start button and open the Control Panel



Windows XP

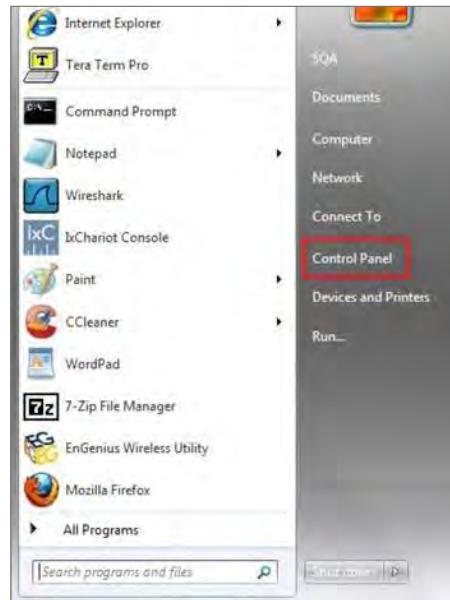

Windows 7

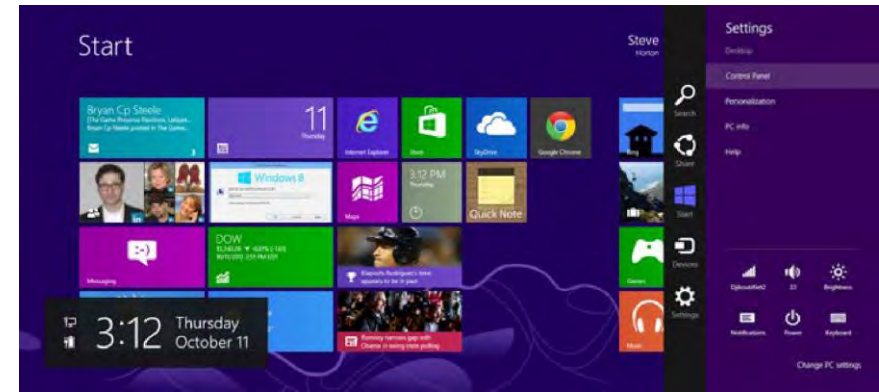

Windows 8

1c. In Windows 10, click Start to select All APPs to enter the folder of Windows system for selecting Control Panel.

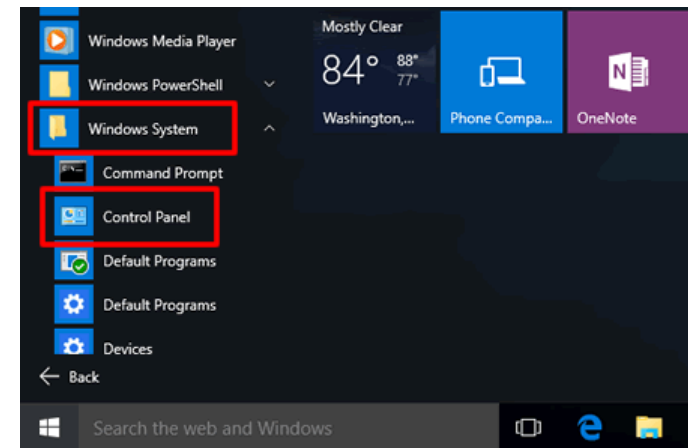

Windows 10

1b. Move your mouse to the lower right hot corner to display the Charms Bar and select the Control Panel in Windows 8 OS.

2a. In Windows XP, click Network Connections.



2b. In Windows 7/Windows 8/Windows 10, click View Network Status and Tasks in the Network and Internet section, then select Change adapter settings.

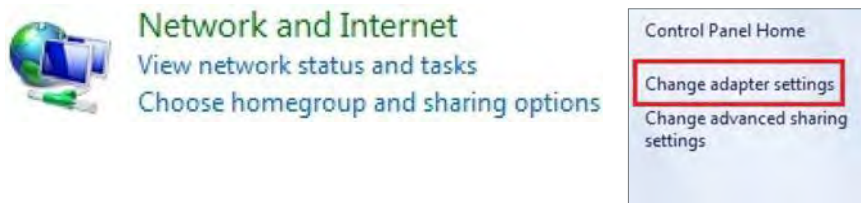

3. Right click on Local Area Connection and select Properties.

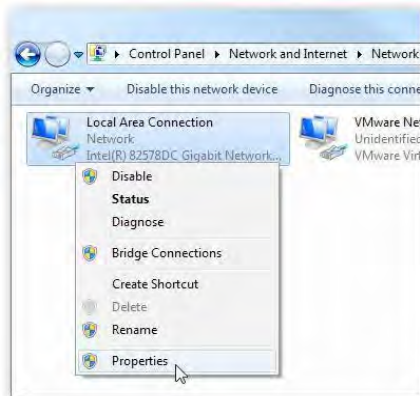

4. Select Internet Protocol Version 4 (TCP/IPv4) and then select Properties.

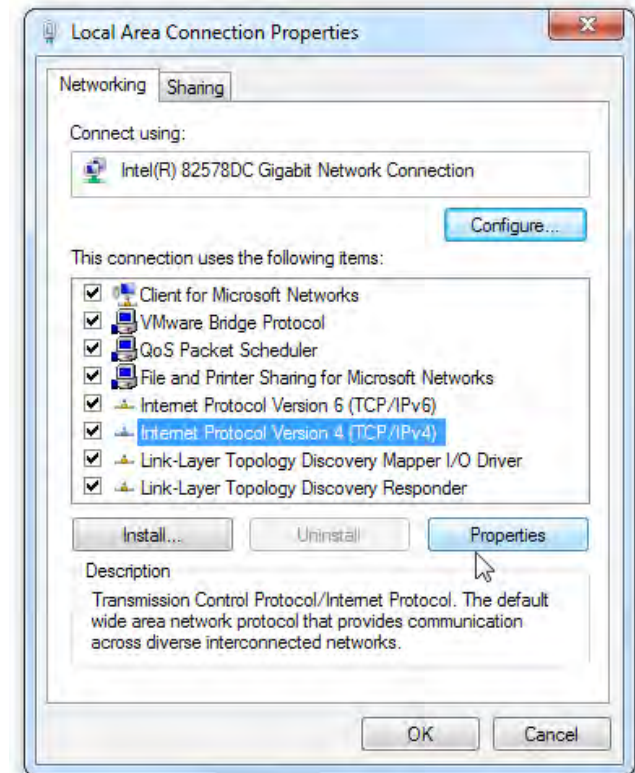

5. Select Use the following IP address and enter an IP address that is different from the Access Point and Subnet mask, then click OK.

Note: Ensure that the IP address and Subnet mask are on the same subnet as the device.

For example: EnStation6 IP address: 192.168.1.1

PC IP address: 192.168.1.2–192.168.1.255

PC Subnet mask: 255.255.255.0

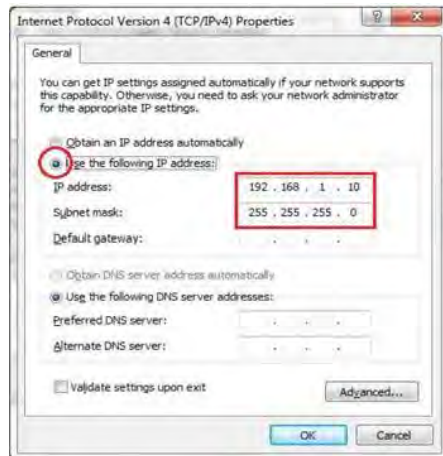

## Apple Mac OS X

1. Go to System Preferences (Which can be opened in the Applications folder or selecting it in the Apple Menu).
2. Select Network in the Internet & Network section.



3. Highlight Ethernet.
4. In Configure IPv4, select Manually.
5. Enter an IP address that is different from the Access Point and Subnet mask then press OK.

Note: Ensure that the IP address and Subnet mask are on the same subnet as the device.

For example: ENH500-AX IP address: 192.168.1.1

PC IP address: 192.168.1.2–192.168.1.255

PC Subnet mask: 255.255.255.0

. Click Apply when done.





# Hardware Installation - EnStation6

1. Remove the rear bottom panel.
2. Connect one end of the Ethernet cable into the main LAN port (PoE) of the Access Point and the other end to the AP Ethernet port on the PoE Adapter.
3. Connect the Power cord to the PoE Adapter and plug the other end in to an electrical outlet.
4. Connect the second Ethernet cable into the LAN port of the PoE Adapter and the other end to the Ethernet port on the computer.
5. Place the panel back into device

Note: The EnStation6 should ONLY be powered via Ethernet cable connected to included supports the included PoE Adapter. You may use either one as the power source.

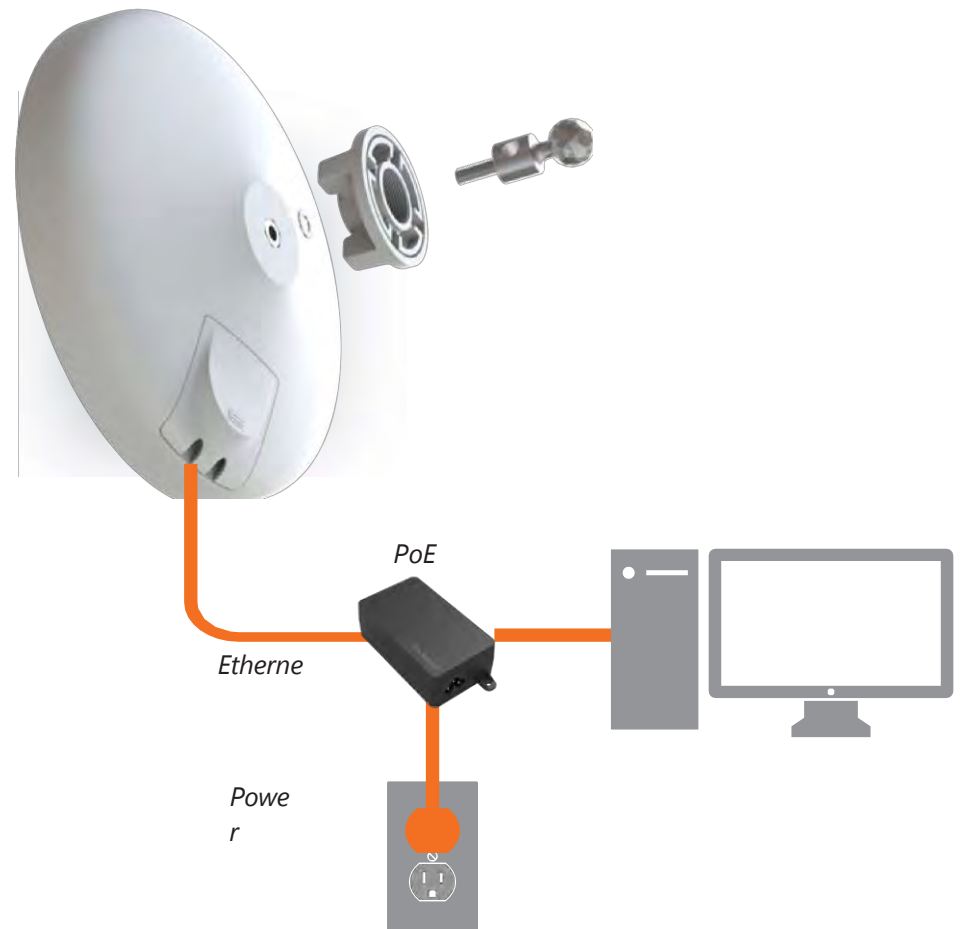

# Mounting the EnStation6

Using the provided hardware, the can be attached to a wall or a pole.

1. Device

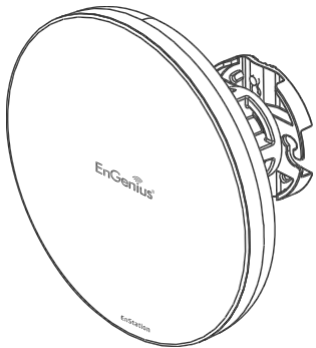

2. PoE Adapter & Power Cord



3. Bracket



4. Pole Mounting Strap



5. Screw Set Kit

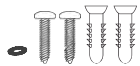

6. Sealing Nut

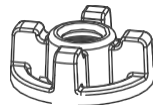

7. Dynamic Stick



## Wall mounting the EnStation6

1. Plug the dynamic stick into the bracket.
2. Screw the sealing nut and assembled parts, as well as tighten it.
3. Put the nock washer on the dynamic stick.
4. Assemble the mounting parts to the EnStation.
5. Determine the mounting location. Mark and drill two pilot holes aligning to the screw holes of the bracket.
6. Put wall anchors into the holes and insert screw into the wall anchor.
7. Screw and secure the bracket in the place.

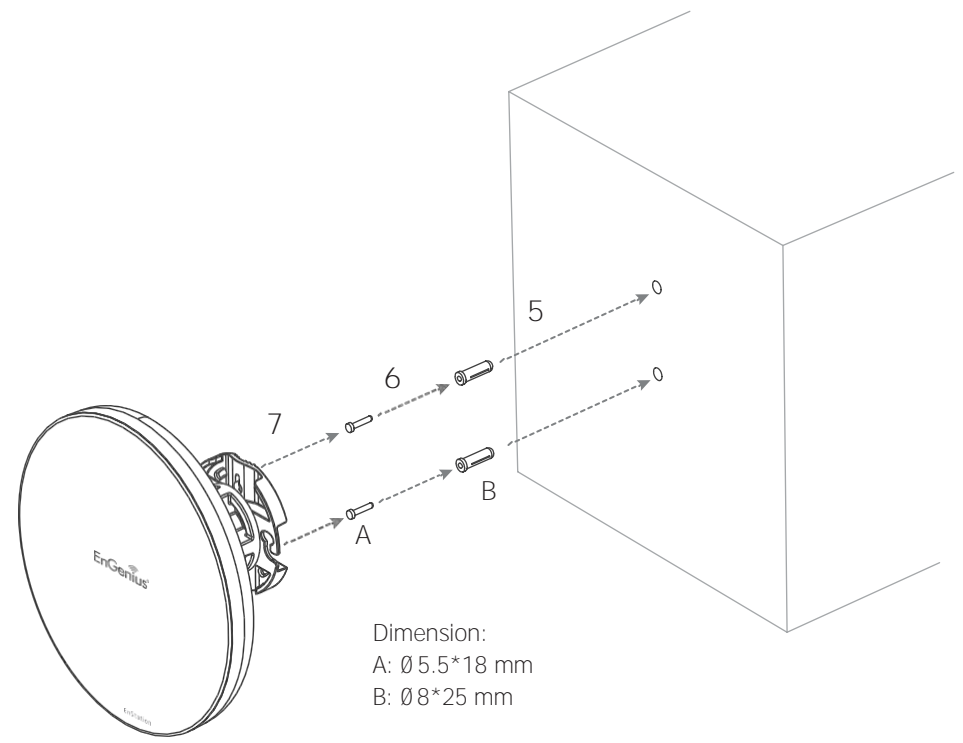
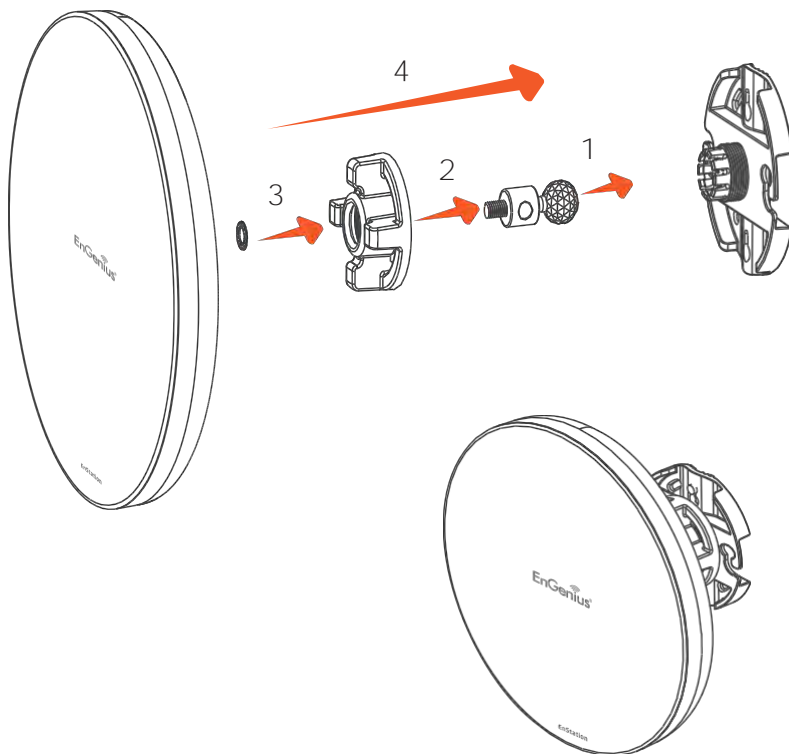

## Pole mounting the EnStation6

1. Plug the dynamic stick into the bracket.
2. Screw the sealing nut and assembled parts, as well as tighten it.
3. Put the nock washer on the dynamic stick.
4. Assemble the mounting parts to the EnStation.
5. Thread the open end of the pole strap through the two tabs on the bracket.
6. Lock and tighten pole strap to secure bracket to the pole.

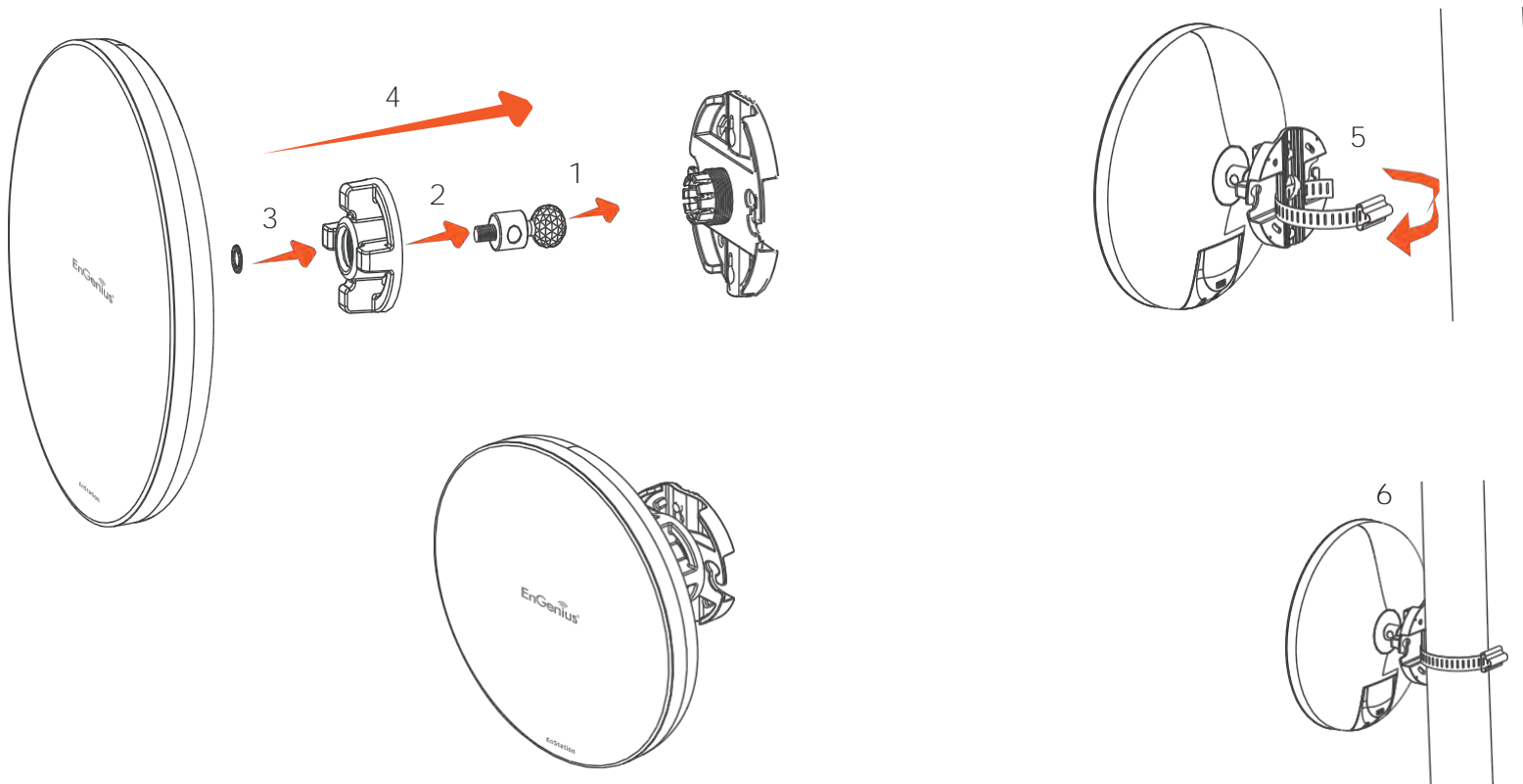

# Mounting the ENH500-AX

Using the provided hardware, the device can be attached to a wall or a pole. The height should not exceed 2 meter.

## 1. Wall Mounting Kit

(Anchors:  $\Phi 5.5 \times 18$  mm & Bolts:  $\Phi 8 \times 25$  mm)



## 2. Pole Mounting Strap

( $\Phi 66 \times 12.6$  mm)

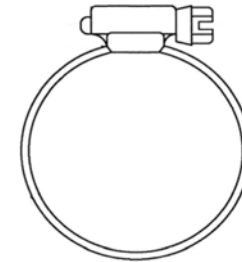

## Wall mounting the ENH500-AX

- A. Determine where the Access Point to be placed and stick the Adhesive label on the surface.
- B. Use the appropriate drill bit to drill two 8.1mm diameter and 26mm depth holes on the markings of the label.
- C. Remove the label and screw the anchors into the holes until they are flush with the wall.
- D. Screw the included screws into the anchors. Place the Access Point against wall with the mounting screw heads.

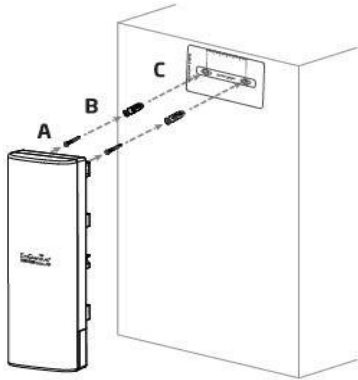

## Pole mounting the ENH500-AX

- A. Thread the open end of the Pole Strap through the two tabs on the Pole Mount Bracket.
- B. Lock and tighten Pole Strap to secure Pole Mount Bracket to the pole.

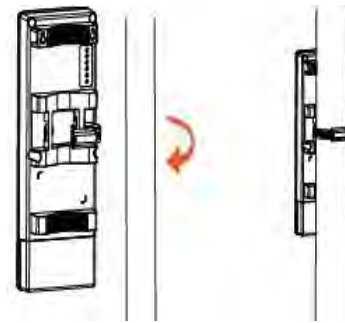

Chapter 3

# **Configuring Your Access Point**

# Configuring Your Access Point

This section will show you how to configure the device by using the web-based configuration interface or EnGenius EnWiFi App, which is a management tool to enable easy deployment on outdoor APs/CPEs. In conjunction with the EnWiFi App, outdoor APs/CPEs can perform configuration changes en-masse, monitoring, firmware upgrades, and data backups from a smart phone or tablet.

## Web Interface Configuration

### Default Setting

Please use your Ethernet port or wireless network adapter to connect the Access Point.

IP Address	192.168.1.1
Username / Password	admin / admin

1. Open a web browser (Internet Explorer/Firefox/Safari/Chrome) and enter the IP Address `http://192.168.1.1`

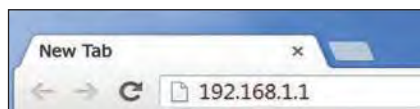

Note: If you have changed the default LAN IP Address of the Access Point, ensure you enter the correct IP Address.

2. The default username and password are admin. Once you have entered the correct username and password, click the Login button to open the web-based configuration page.

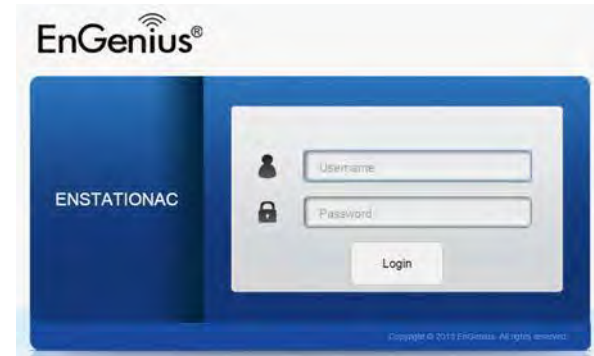

\* The model name will be varied by different models

3. If successful, you will be logged in and see the **device's** User Interface.





# EnWiFi App Configuration

## Download EnWiFi App

1. Please download and install EnWiFi App from Google Play or iOS App Market .



Android



iOS

2. Before access to device, you need to find Management SSID and connect to it first. Then you can see your device in the Device List.

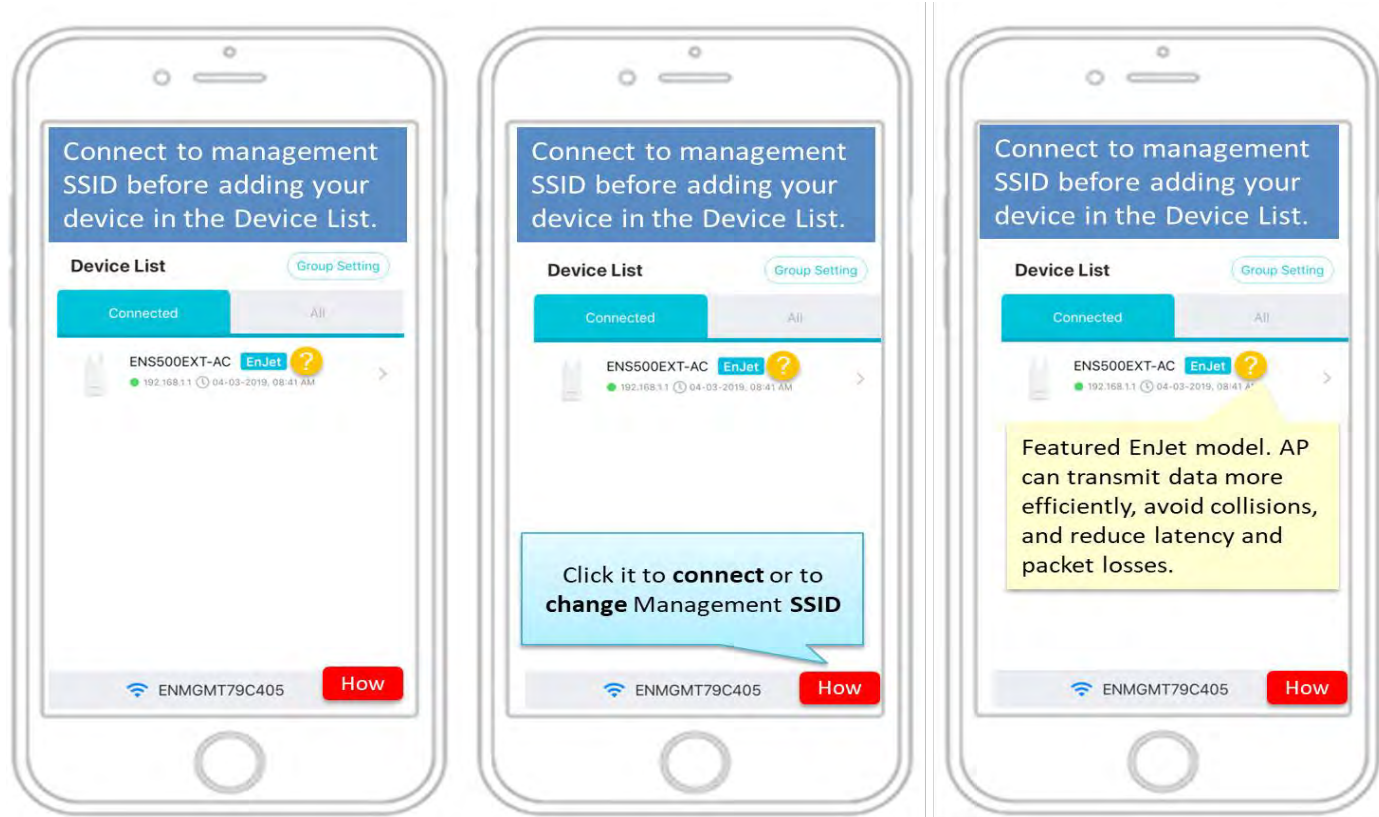

3. For more details of how to configure and management device via EnWiFi App, please see Chpater 9 EnWiFi App.

Chapter 4

# **Building a Wireless Network**

Before starting to configure this Access Point, you may realize the used scenario under varied operating modes. It can be configured as an: Access Point, Client Bridge or WDS (AP, Station & Bridge). This chapter describes purpose of different operating modes and lists down the operation modes for EnStation6/ENH500-AX.

## Access Point Mode

In Access Point Mode, device behaves like a central connection for stations or clients that support IEEE 802.11ac/a/n networks. The stations and clients must be configured to use the same SSID (Service Set Identifier) and security password to associate with the EnStationAC. The EnStationAC supports up to one (1)/eight (8) SSIDs per band when EnJet enabled/disabled at the same time for secure access.

## Client Bridge Mode

The device essentially acts as a wireless adapter that connects to an access point to allow a system of wireless access to the network in the Client Bridge mode. Since the client is on the same subnet, the device can broadcast to reach the client device.

If you use the client bridge mode in the device, you can use the AP Detection feature to scan for Access Points within range. When you find an Access Point, configure the device to use the same SSID and Security Password as the Access Point to associate with it.



## WDS AP Mode

The device also supports WDS AP mode. This operating mode allows wireless connect to the other device via using WDS technology. In this mode, configure the MAC addresses in both Access Points to enlarge the wireless area by enabling WDS Link settings. WDS supports up to four (4) AP MAC addresses.

## WDS Bridge Mode

In WDS Bridge Mode, the device can wirelessly connect different LANs by configuring the MAC address and security settings of each device. Use this mode when two wired LANs located a small distance apart want to communicate with each other. The best solution is to use the device to wirelessly connect two wired LANs, as shown in the following diagram.

WDS Bridge Mode can establish up to four WDS links, creating a star-like network.

Note: WDS Bridge Mode does not act as an Access Point. Access Points linked by WDS are using the same frequency channel. More Access Points connected together may lower throughput.



## WDS Station Mode

Station mode expands the WDS by receiving a wireless signal/service and sharing it through the Ethernet port.



# Chapter 5

# **Status**



# Main Status

## Save Changes

This page lets you save and apply the settings shown under Unsaved changes list, or cancel the unsaved changes and revert to the previous settings that were in effect.



\*The model name will be varied by different models.

## Device Status

Clicking the Device Status link under the Overview menu shows the status information about the current operating mode.

- The Device Information section shows general system information such as Device Name, MAC Address, Current Time, Firmware Version, and Management VLAN ID

Note: VLAN ID information is only applicable in Access Point or WDS AP mode.

### Device Information

Device Name	ENS620EXT
MAC Address	
- LAN1	88:DC:96:00:00:10
- LAN2	88:DC:96:00:00:11
- Wireless LAN - 2.4GHz	88:DC:96:00:00:12
- Wireless LAN - 5GHz	88:DC:96:00:00:13
Country	USA
Current Local Time	Tue Jul 12 11:45:00 2016
Uptime	0h 4m 57s
Firmware Version	1.0.0
Management VLAN ID	Untagged

\*The model name will be varied by different models.

- The Memory Information section shows usage of memory such as Total Available, Free, Cached, Buffered

### Memory Information

Total Available	128884 kB / 236336 kB (54%)
Free	95352 kB / 236336 kB (40%)
Cached	24908 kB / 236336 kB (10%)
Buffered	8624 kB / 236336 kB (3%)

- The LAN Information section shows the Local Area Network settings such as the LAN IP Address, Subnet mask, and DNS Address.

LAN Information - IPv4	
IP Address	192.168.1.1
Subnet Mask	255.255.255.0
Gateway	192.168.1.1
Primary DNS	0.0.0.0
Secondary DNS	0.0.0.0
DHCP Client	Disable
Spanning Tree Protocol (STP)	Disable
LAN Information - IPv6	
IP Address	N/A
Link-Local Address	fe80::8adc:96ff:fe06:3c94
Gateway	N/A
Primary DNS	N/A
Secondary DNS	N/A

- The Wireless LAN Information 5 GHz section shows wireless information such as Operating Mode, Frequency, and Channel. Since the AP/CPE supports multiple-SSIDs, information about each SSID, the ESSID, and security settings, are displayed

Note: Profile Settings are only applicable in Access Point and WDS AP modes.

Wireless LAN Information - 5GHz				
Operation Mode	AP			
Wireless Mode	802.11 A/N			
Channel Bandwidth	40 MHz			
Channel	5.66 GHz (Channel 132)			
Distance	1000 M			
Profile	SSID	Security	VID	802.1Q
#1	EnGenius063C97_1-5GHz	None	51	Disable
#2	EnGenius063C97_2-5GHz	None	52	Disable
#3	EnGenius063C97_3-5GHz	None	53	Disable
#4	EnGenius063C97_4-5GHz	None	54	Disable
#5	EnGenius063C97_5-5GHz	None	55	Disable
#6	EnGenius063C97_6-5GHz	None	56	Disable
#7	EnGenius063C97_7-5GHz	None	57	Disable
#8	EnGenius063C97_8-5GHz	None	58	Disable

- The Statistics section shows Mac information such as SSID, MAC address, RX and TX.

Statistics				
	SSID	MAC	RX(Packets)	TX(Packets)
Ethernet		00:02:8F:FF:FF:FF	75.57KB(856 PKts.)	455.926KB(399 PKts.)
	EnGenius063C96_1-2.4GHz	88:DC:96:06:3C:96	0KB(0 PKts.)	0.792KB(4 PKts.)
	EnGenius063C97_1-5GHz	88:DC:96:06:3C:97	0KB(0 PKts.)	0KB(0 PKts.)

# Connection

## 5 GHz Connection List

Click the connection link under the Overview menu displays the connection list of clients associated to the **AP/CPE's** 5 GHz, along with the MAC addresses and signal strength for each client. Clicking Refresh updates the client list.

Note: Only applicable in Access Point and WDS AP modes.

## WDS Link List

Click the connection link under the Overview menu. This page displays the current status of the WDS link, including WDS Link ID, MAC Address, Link Status and RSSI.

Note: Only applicable in WDS AP and WDS Bridge modes.



# Realtime

The Realtime section contains the following options:

CPU Loading: 3 minutes CPU loading percentage information, it displays current loading, average loading and peak loading status. Left bar is loading percentage; button is time tracing. Interval is every 3 seconds

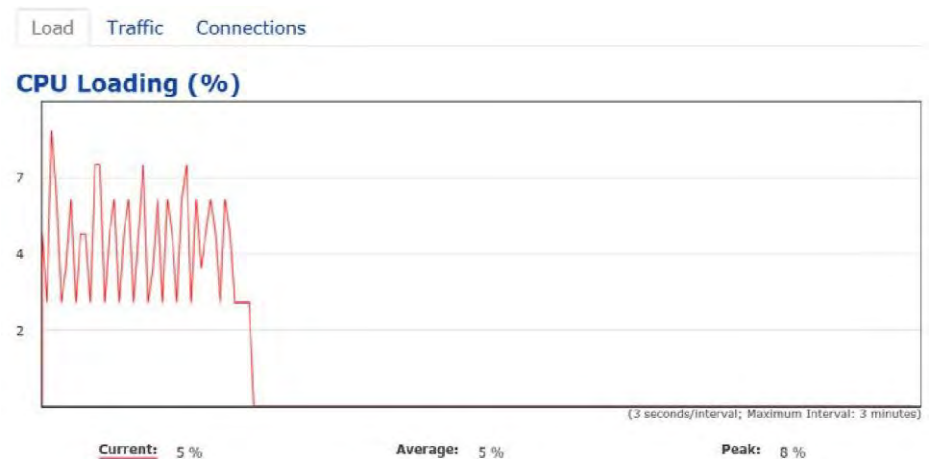

Traffic Loading: 5GHz and Ethernet port inbound and outbound traffic by current, average and peak time.

Realtime Connection (Pkts): Overview on current active network connections. It displays UDP and TCP packets information and other connection status. UDP connections curve is in blue; TCP connection curve is in green; others curve is in red. Below of chart shows connections source and destination.

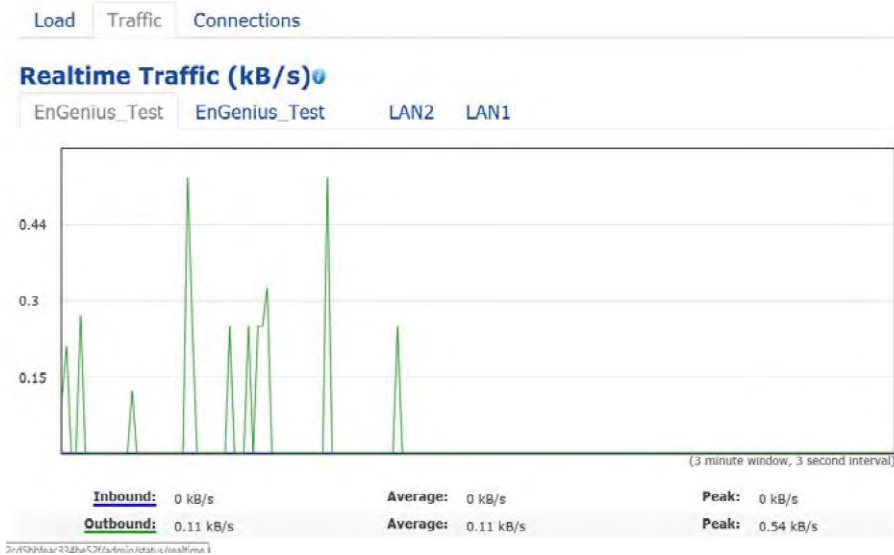

# Chapter 6

# **Network**

# Basic IP Settings

## IPv4/IPv6 Settings

This page allows you to modify the **device's** IP settings.

IPv4 Settings	
IP Network Setting	Static IP ▾
IP Address	192.168.1.1
Subnet Mask	255.255.255.0
Gateway	192.168.1.1
Primary DNS	0.0.0.0
Secondary DNS	0.0.0.0
IPv6 Settings	<input checked="" type="checkbox"/> Link-local Address
IP Address	
Subnet Prefix Length	
Gateway	
Primary DNS	
Secondary DNS	

**IP Network Settings:** Select whether the device IP address will use a static IP address specified in the IP address field or be obtained automatically when the device connects to a DHCP server.

**IP Address:** The IP address of this device.

**Subnet Mask:** The IP Subnet mask of this device.

**Gateway:** The Default Gateway of this device. Leave it blank if you are unsure of this setting.

**Primary/Secondary DNS:** The primary/secondary DNS address for this device.

**Save:** Click Save to confirm the changes.

## Spanning Tree Protocol (STP) Settings

This page allows you to modify the Spanning Tree settings. Enabling the Spanning Tree protocol will prevent network loops in your LAN network.

Spanning Tree Protocol (STP) Settings		
Status	Disable ▾	
Hello Time	2	seconds (1-10)
Max Age	20	seconds (6-40)
Forward Delay	4	seconds (4-30)
Priority	32768	(0-65535)

**Spanning Tree Status:** Enables or disables the Spanning Tree function.

**Hello Time:** Specifies Bridge Hello Time in seconds. This value determines how often the device sends handshake packets to communicate information about the topology throughout the entire Bridged Local Area Network.

**Max Age:** Specifies Bridge Max Age in seconds. If another bridge in the spanning tree does not send a hello packet for a long period of time, it is assumed to be inactive.

Forward Delay: Specifies Bridge Forward Delay in seconds. Forwarding delay time is the time spent in each of the Listening and Learning states before the Forwarding state is entered. This delay is provided so that when a new bridge comes onto a busy network, it analyzes data traffic before participating in the network.

Priority: Specifies the Priority Number. A smaller number has a greater priority than a larger number.

Save: Click Save to confirm the changes.

# Chapter 7

# **Wireless**



# Wireless

## Wireless Settings

Wireless Settings	
Device Name	<input type="text" value="EnStation5-AC"/>
Country / Region	<input type="text" value="Canada"/>

\*The model name will be varied by different models.

Device Name: Enter a name for the device. The name you type appears in SNMP management. This name is not the SSID and is not broadcast to other devices.

Save: Click Save to confirm the changes.

This page displays the current status of the Wireless service settings of the AP/CPE.

## Wireless Network

EnStation6/ENH500-AX supports 802.11ax/ac/n mixed mode in 5 GHz.

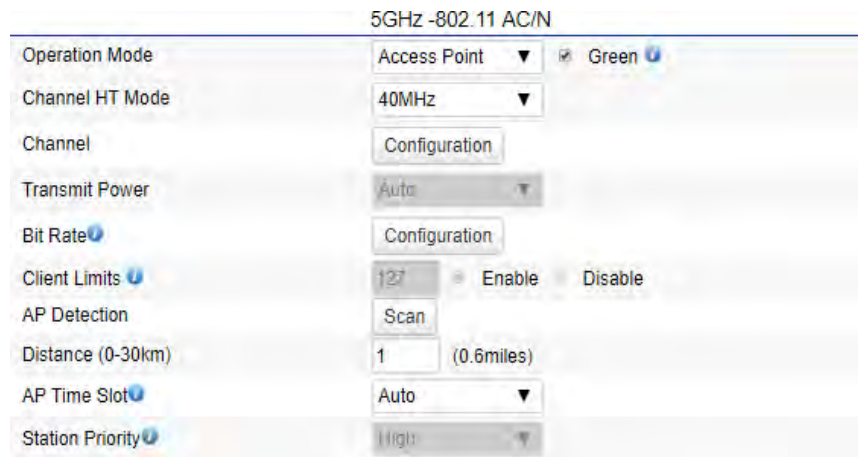

**5GHz -802.11 AC/N**

- Operation Mode: Access Point  Green
- Channel HT Mode: 40MHz
- Channel: Configuration
- Transmit Power: Auto
- Bit Rate: Configuration
- Client Limits: 127  Enable  Disable
- AP Detection: Scan
- Distance (0-30km): 1 (0.6miles)
- AP Time Slot: Auto
- Station Priority: High

**Operation Mode:** Select Operation Mode. Access Point, Client Bridge or WDS (AP, Station & Bridge)

**Channel HT Mode:** The default channel bandwidth is 20 MHz/ 40 /80 MHz. The larger the channel, the greater the transmission quality and speed.

**Channel:** Click Configuration button to open a new windows to configure channels for performing wireless

**5GHz**

All	None
U-NII-1	U-NII-2A
U-NII-2B	U-NII-3
Ch 36 : 5.180 GHz	Ch 40 : 5.200 GHz
Ch 44 : 5.220 GHz	Ch 48 : 5.240 GHz
Ch 52 : 5.260 GHz	Ch 56 : 5.280 GHz
Ch 60 : 5.300 GHz	Ch 64 : 5.320 GHz
Ch100 : 5.500 GHz	Ch104 : 5.520 GHz
Ch108 : 5.540 GHz	Ch112 : 5.560 GHz
Ch132 : 5.660 GHz	Ch136 : 5.680 GHz
Ch149 : 5.745 GHz	Ch153 : 5.765 GHz
Ch157 : 5.785 GHz	Ch161 : 5.805 GHz

**Transmit Power:** Sets the power output of the wireless signal.

**Bit Rate:** 5GHz is default 6 Mbps, the range can control by BAR via scroll from 6Mbps to 54Mbps.

**2.4GHz**

Minimum bitrate (Mbps)

Lower Data Rate Higher Data Rate

1 2 5.56 9 11 12 18 24 36 48 54

Save Save current setting(s)

**AP Detection:** AP Detection can select the best channel to

use by scanning nearby areas for Access Points.

Distance: Specifies the distance between Access Points and client devices. The proper setting for this parameter may assist Access Points to avoid the improper operation when transmitting data under a filed application.

\*High level means this client will get 10/16 of **AP's** time resource.

Client Limits: 127  
AP Detection: Scan  
Distance (0-30km): 1 (0.6miles)  
AP Time Slot: Auto  
Station Priority: High

## Wireless Setting-5GHz

Current Profile: You can configure up to eight(8)different SSIDs If multiple client devices will be accessing the network, you can arrange the devices into SSID groups. Click Edit

to configure the profile and check whether you want to enable extra SSID.

## SSID Profile

Wireless Settings - Access Point					
Enabled	SSID	Edit	Security	Guest Network	VLAN ID
<input checked="" type="checkbox"/>	EnGenius79C393_1	Edit	None	<input type="checkbox"/>	-
<input checked="" type="checkbox"/>	EnGenius79C393_2	Edit	None	<input type="checkbox"/>	-
<input checked="" type="checkbox"/>	EnGenius79C393_3	Edit	None	<input type="checkbox"/>	-
<input checked="" type="checkbox"/>	EnGenius79C393_4	Edit	None	<input type="checkbox"/>	-
<input checked="" type="checkbox"/>	EnGenius79C393_5	Edit	None	<input type="checkbox"/>	-
<input checked="" type="checkbox"/>	EnGenius79C393_6	Edit	None	<input type="checkbox"/>	-
<input checked="" type="checkbox"/>	EnGenius79C393_7	Edit	None	<input type="checkbox"/>	-
<input checked="" type="checkbox"/>	EnGenius79C393_8	Edit	None	<input type="checkbox"/>	-

Management Interface: This Management interface make you can change the configuration via EnWiFi App instead of using the GUI. Management SSID will be turned off in this two situation. (1)When the device is powered up in the first time and there is no connection in 30 minutes. (2)When the setting is done and idle in 15 minutes. If you need to turn on management SSID please reboot the device.You can set to always on or turn off if idle in 15 minutes.

Management Interface - 2.4G

Enabled	SSID	Edit	Security
<input checked="" type="checkbox"/>	ENMGMT79C393	Edit	WPA2/PSK AES

Always on  Turn off if idle in 15 minutes

**Enable:** Click this check box to enable this SSID interface.  
The default SSIDs are enabled on the first 5GHz SSID.

**SSID:** Specifies the SSID for the current profile.

**Hidden SSID:** Check this option to hide the SSID from clients.  
If checked, the SSID will not appear in the site survey.

**Client Isolation:** Click the appropriate radio button to enable this function for allowing or preventing communication between client devices.

**VLAN Isolation:** Restrict clients communicating with different VLANs by selecting the radio button.

**L2 Isolation:** Enable this function prevent client devices to communicate on the both WLAN and LAN.

**VLAN ID:** Specifies the VLAN tag for each profile. If your network includes VLANs, you can specify a VLAN ID for packets pass through the Access Point with a tag.

**Wireless Security:** See the Wireless Security section.

**Save:** Click Save to accept the changes.

## Wireless Security

The Wireless Security section lets you configure the **AP's** security modes

Wireless Security - 5GHz	
Security Mode	WPA-PSK ▼
Encryption	AES ▼
Passphrase	<input type="text"/>
Group Key Update Interval	3600

Security Mode: Including WPA2-PSK, WPA2-Enterprise. We strongly recommend you to use WPA2-PSK mode.

Wireless Security	
Security Mode	WPA2-Enterprise ▼
Encryption	AES ▼
Group Key Update Interval	3600 (30~3600; 0:Disable)
Radius Server	192.165.100.36
Radius Port	1812
Radius Secret	1234567890123456789012345

Encryption: Default is AES. Please ensure that your wireless clients use the same settings.

Group Key Update Interval: Specifies how often, in

seconds, the Group Key changes. The default value is 3600

Radius Server: Enter the IP address of the Radius server.

Radius Port: Enter the port number used for connections to the Radius server.

Radius Secret: Enter the secret required to connect to the Radius server.

## Radius Settings

NAS-IP: Configure you NAS server address to assign traffic to the destination.

NAS-Ports: Configure your port No. if you would like to enable Network Address Servecie (NAS) under a SSID.

NAS-ID: Configure a NAS ID which is mapped with the SSID. The traffic will be forwarded via the different SSIDs if these SSIDs configured as different ID.

## Radius Accounting

RadiusAccounting: Choose to enable or disable accounting feature.

Radius Accounting Server: Enter the IP address of the Radius accounting server.

Radius Accounting Port Enter the port number used for connections to the Radius accounting server.

Radius Accounting Secret: Enter the secret required to connect to the Radius accounting server.

Interim Accounting Interval: Specifies how often, in seconds, the accounting data sends.

Note: 802.11n does not allow WPA2-PSK TKIP security mode.

## Fast Roaming

Enable the function to serve mobile client devices that roam from Access Point to Access Point. Some applications running on Client devices require fast re-association when they roam to a different Access Point



Please enter the settings of the SSID and initialize the Security mode to WPA2 enterprise, as well as to set the Radius Server firstly. Users can enable the Fast Roaming and implement the advanced search.

Please also set the same enterprise Encryption under the same SSID on other Access Points and enable the Fast Roaming. When the configuration is realized on different Access Point, the mobile client devices can run the voice service and require seamless roaming to prevent delay in conversation from Access Point to Access Point.

## Wireless MAC Filtering

Wireless MAC Filtering is used to allow or deny network access to wireless clients (computers, tablet PCs, NAS, smartphones, etc.) according to their MAC addresses. You can manually add a MAC address to restrict permission to access the AP/CPE. The default setting is: Disable Wireless MAC Filter.

Note: Only applicable in Access Point and WDS AP modes.

ACL Mode: Determines whether network access is granted or denied to clients whose MAC addresses appear in the MAC address table on this page. Your choices are: Disabled, Deny MAC in the list, or Allow MAC in the list.

MAC Address: Enter the MAC address of the wireless client.

Add: Click Add to add the MAC address to the MAC address table.

Delete: Delete the selected entries.

Save: Click Save to apply the changes.

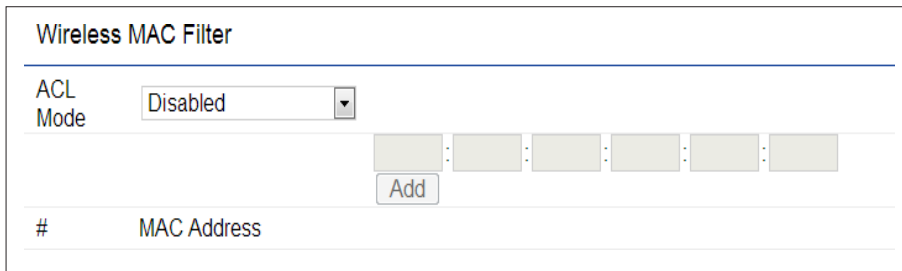

The screenshot shows the 'Wireless MAC Filter' configuration interface. At the top, there is a title 'Wireless MAC Filter'. Below the title, the 'ACL Mode' is set to 'Disabled' in a dropdown menu. Underneath, there is a row of six empty input boxes for entering a MAC address, separated by dots. Below these boxes is an 'Add' button. At the bottom, there is a table header with two columns: '#' and 'MAC Address'.

## Wireless Traffic Shaping

Traffic shaping regulates the flow of packets leaving an interface to deliver improved Quality of Service(QoS). The function will allow administrators to restrict the wireless bandwidth per SSID or per user.

Wireless Traffic Shaping	
Enable Traffic Shaping	<input checked="" type="radio"/> Enable <input type="radio"/> Disable
Download Limit	<input type="text" value="100"/> <input type="checkbox"/> Per User Mbps (1-999)
Upload Limit	<input type="text" value="100"/> <input type="checkbox"/> Per User Mbps (1-999)

Enable Traffic Shaping: Check this option to enable Wireless Traffic Shaping.

Download Limit: Specifies the wireless transmission bandwidth used for downloading.

Upload Limit: Specifies the wireless transmission bandwidth used for uploading.

Save: Click Save to confirm the changes.



## Guest Network Settings

When EnJet disabled, you can add a guest network which allows visitors to use the Internet without giving out your office or company wireless security key. You can add a guest network to each wireless network in the 5 GHz ac/a/n frequencies.



The screenshot shows the 'Guest Network Settings' configuration page. At the top, there is a table with columns: Enable, SSID, Edit, Security, Hidden SSID, and Client Isolation. Below this table, there are sections for 'Manual IP Settings' and 'Automatic DHCP Server Settings'. The 'Manual IP Settings' section includes fields for IP Address (192.168.200.1) and Subnet Mask (255.255.255.0). The 'Automatic DHCP Server Settings' section includes fields for Starting IP Address (192.168.200.100), Ending IP Address (192.168.200.200), and WINS Server IP (0.0.0.0).

SSID: Specifies the SSID for the current profile.

Suppressed SSID: Check this option to hide the SSID from clients. If checked, the SSID will not appear in the site survey.

Station Separation: Click the appropriate radio button to allow or prevent communication between client devices.

IP Address: The IP Address of this device.

Subnet Mask: The IP Subnet mask of this device.

Starting IP Address: The first IP Address in the range of

the addresses by the DHCP server.

Ending IP Address: The last IP Address in the range of addresses assigned by the DHCP server.

## RSSI Threshold

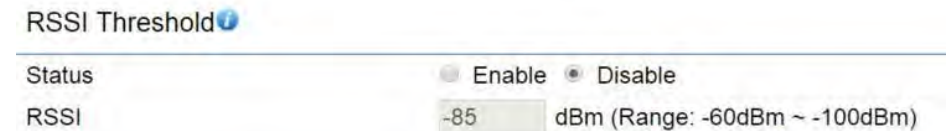

The screenshot shows the 'RSSI Threshold' configuration page. It features a 'Status' section with radio buttons for 'Enable' and 'Disable', where 'Disable' is selected. Below this, there is an 'RSSI' field with a value of '-85' and a label 'dBm (Range: -60dBm ~ -100dBm)'.

RSSI Threshold: Enable the Fast Handover feature when EnJet disable by ensuring that each client is served by at least one Access Point at any time. Access Points continuously monitor the connectivity quality of any client in their range and efficiently share this information with other Access Points in the vicinity of that client to coordinate which of them should serve the client best.

RSSI: Enter the RSSI (Received Signal Strength Index) in order to determine the handover procedure which the current wireless link will terminate. RSSI is an indication of the power level being received by the antenna. Therefore, the higher the RSSI number, the stronger the signal.

## Management VLAN Settings

This page allows you to assign a VLAN tag to packets sent over the network. A VLAN is a group of computers on a network whose software has been configured so that they behave as if they were on a separate Local Area Network (LAN). Computers on VLAN do not have to be physically located next to one another on the LAN.

Note: Only applicable in Access Point and WDS AP modes.

Management VLAN: If your network includes VLANs, you can enable Management VLAN ID for packets passing through the Access Point with a tag.

Save: Click Save to confirm the changes or Cancel to cancel and return to previous settings.

Note: If you reconfigure the Management VLAN ID, you may lose your connection to the EnStationAC. Verify that the DHCP server supports the reconfigured VLAN ID and then reconnect to the EnStationAC using the new IP address.

Management VLAN Settings	
<b>CAUTION:</b> If you reconfigure the Management VLAN ID, you may lose connectivity to the access point. Verify that the switch and DHCP server can support the reconfigured VLAN ID, and then re-connect to the new IP address.	
Management VLAN	Enable <input type="checkbox"/> 4096

Chapter 8

# **Management**

# Advanced Settings

## SNMP Settings

This page allows you to assign the Contact Details, Location, Community Name, and Trap Settings for a Simple Network Management Protocol (SNMP). SNMP is a networking management protocol used to monitor network attached devices. SNMP allows messages (called protocol data units) to be sent to various parts of the network. Upon receiving these messages, SNMP compatible devices (called agents) returns the data stored in their Management Information Bases.

SNMP Settings	
Status	Enable ▾
Contact	<input type="text"/>
Location	<input type="text"/>
Port	161 <input type="text"/>
Community Name (Read Only)	public <input type="text"/>
Community Name (Read Write)	private <input type="text"/>
Trap Destination	
- Port	162 <input type="text"/>
- IP Address	<input type="text"/>
- Community Name	public <input type="text"/>
SNMPv3 Settings	
- Status	Enable ▾
- Username	admin <input type="text"/> (1-31 Characters)
- Authorized Protocol	MD5 ▾
- Authorized Key	12345678 <input type="text"/> (8-32 Characters)
- Private Protocol	DES ▾
- Private Key	12345678 <input type="text"/> (8-32 Characters)
- Engine ID	<input type="text"/>

SNMP Enable/Disable: Enables or disables the SNMP feature.

Contact: Specifies the contact details of the device.

Location: Specifies the location of the device.

Community Name (Read Only): Specifies the password for the SNMP community for read only access.

Community Name (Read/Write): Specifies the password for the SNMP community with read/write access.

Trap Destination Address: Specifies the IP address of the computer that will receive the SNMP traps.

Trap Destination Community Name: Specifies the password for the SNMP trap community.

SNMPv3: Enables or disables the SNMPv3 feature.

User Name: Specifies the username for SNMPv3.

Auth Protocol: Selects the authentication protocol type: MDS or SHA.

Auth Key: Specifies the authentication key.

Priv Protocol: Selects the privacy protocol type: DES.

Priv Key: Specifies the privacy key for privacy.

Engine ID: Specifies the engine ID for SNMPv3.

Apply Save: Click Apply Save to apply the changes.

## CLI Settings

CLI Setting	
CLI	Enable
SSH Setting	
SSH	Disable
HTTPS Setting	
HTTPS	Enable
HTTPS forward	Disable

CLI: The Command Line Interface (CLI) allows you to type commands instead of choosing them from a menu or selecting an icon.

SSH: Enable Secure Shell (SSH) to make secure, encrypted connections in the network. Secure Shell is a network protocol that allows data to be exchanged using a secure channel between two network devices.

HTTPS: Enable HTTPS to transfer and display web content securely. The Hypertext Transfer Protocol over SSL (Secure Socket Layer) is a TCP/IP protocol used by web servers to transfer and display web content securely.

## Email Alert

You can use the Email Alert feature to send messages to the configured email address when particular system events occur.

Note: Do NOT use your personal email address as it can unnecessarily expose your personal email login credentials. Use a separate email account made for this feature instead

Email Alert	
Status	<input checked="" type="checkbox"/> Enable
- From	<input type="text"/>
- To	<input type="text"/>
- Subject	[Email-Alert][ENH900EXT][00:02:6F:FF:FF:FF] Config
Email Account	
- Username	<input type="text"/>
- Password	<input type="password"/>
- SMTP Server	<input type="text"/> Port: 25
- Security Mode	None <input type="button" value="Send Test Mail"/>

From: Enter the email address to show the sender of the email.

To: Enter the address that you wish to send emails to.

Subject: Enter the text that you wish to appear in the **email's** subject line.

Username: Enter the username for the email account that will be used to send emails.

Password: Enter the password for the email account that will be used to send emails.

SMTP Server: Enter the IP address or hostname of the outgoing SMTP server.

Port: Enter the SMTP port number to use for outbound emails.

Security Mode: Selects the security mode: SSL/TLS or STARTTLS or None.

Apply: To save setting and take effect.

# Time Zone

## Date and Time Setting

This page allows you to set the internal clock of the device.

**Date and Time Settings**

Manually Set Date and Time

Date: 2019 / 07 / 09

Time: 15 : 03 (24-Hour)

Automatically Get Date and Time

NTP Server: pool.ntp.org

Manually Set Date and Time: Manually specify the date and time.

Automatically Get Date and Time: Select and check whether you wish to enter the IP address of an NTP server or use the default NTP server to have the internal clock set automatically.

## Time Zone

You can click Auto Detect or select Time Zone from the

menu.

Enable Daylight Saving: Check whether daylight savings applies to your area.

Start: Select the day, month, and time when daylight savings time starts.

End: Select the day, month, and time when daylight savings times ends.

**Time Zone**

Auto Detect

Time Zone: UTC+00:00 England ▼

Enable Daylight Saving

Start: January ▼ 1s ▼ Sun ▼ 00:00 ▼

End: January ▼ 1s ▼ Mon ▼ 00:00 ▼

# Auto Reboot Settings

You can specify how often you wish to reboot the EnStationAC.

Auto Reboot Setting	
Auto Reboot Status	<input type="button" value="Disable"/>
Timer	<input type="checkbox"/> Sunday <input type="checkbox"/> Monday <input type="checkbox"/> Tuesday <input type="checkbox"/> Wednesday <input type="checkbox"/> Thursday <input type="checkbox"/> Friday <input type="checkbox"/> Saturday
	0 : 0

Auto Reboot Setting: Enables or disables the Auto Reboot function.

Frequency of Auto Reboot: Specifies how often you wish to reboot the EnStationAC by Min, Hour, Day or Week.

Timer: Select the day and enter the time you would like to reboot automatically.

Save: Click Save to apply the changes.



# Wi-Fi Scheduler

The Wi-Fi Scheduler can be created for use in enforcing rules. For example, if you wish to restrict web access to Mon-Fri from 3pm to 8pm, you could create a schedule selecting Mon, Tue, Wed, Thu and Fri while entering a Start time of 3pm and End Time of 8pm to limit access to these times.

Day	Availability	Duration
Sunday	available ▾	00 : 00 ~ 24 : 00
Monday	available ▾	00 : 00 ~ 24 : 00
Tuesday	available ▾	00 : 00 ~ 24 : 00
Wednesday	available ▾	00 : 00 ~ 24 : 00
Thursday	available ▾	00 : 00 ~ 24 : 00
Friday	available ▾	00 : 00 ~ 24 : 00
Saturday	available ▾	00 : 00 ~ 24 : 00

Status: Enables or disables the Wi-Fi scheduler function.

Wireless Radio: Select 2.4 GHz or 5 GHz from the drop-down list for the preferred band type.

SSID Selection: Select a SSID from the drop-down list.

Schedule Templates: Select a schedule template from the

drop-down list.

Day(s): Place a checkmark in the boxes for the desired days or select the All Week radio button to select all seven days of the week.

Duration: The Start Time is entered in two fields. The first box is for hours and the second box is for minutes. The End Time is entered in the same format as the Start time.

# Tools

## Ping Test Parameters

This page allows you to analyze the connection quality of the EnStationAC and trace the routing table to a target in the network.

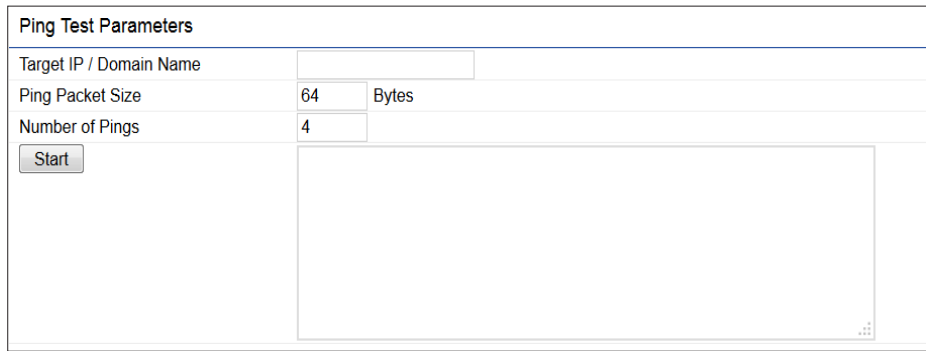

The screenshot shows a web form titled "Ping Test Parameters". It contains three input fields: "Target IP / Domain Name" (empty), "Ping Packet Size" (set to 64 Bytes), and "Number of Pings" (set to 4). Below these fields is a "Start" button and a large empty text area for results.

Target IP: Enter the IP address you would like to search.

Ping Packet Size: Enter the packet size of each ping.

Number of Pings: Enter the number of times you wish to ping.

## Traceroute Test Parameter

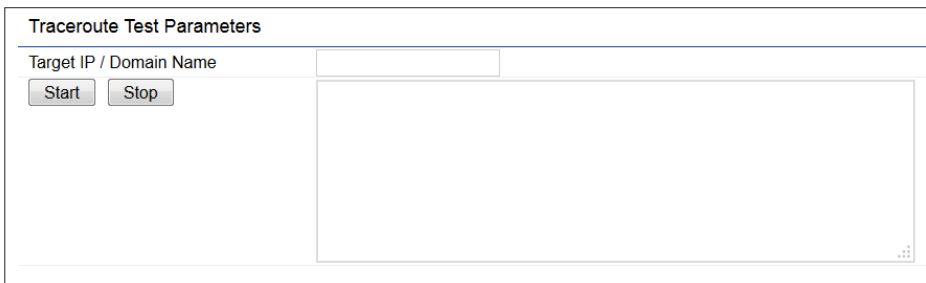

The screenshot shows a web form titled "Traceroute Test Parameters". It contains one input field: "Target IP / Domain Name" (empty). Below this field are "Start" and "Stop" buttons and a large empty text area for results.

Target IP: Enter the IP address you would like to trace

## Nslookup Test Parameter

Target IP/Domain Name: Enter the IP address or domain name you wish to do Nslookup test.

## Speed Test Parameters

### Speed Test Parameters

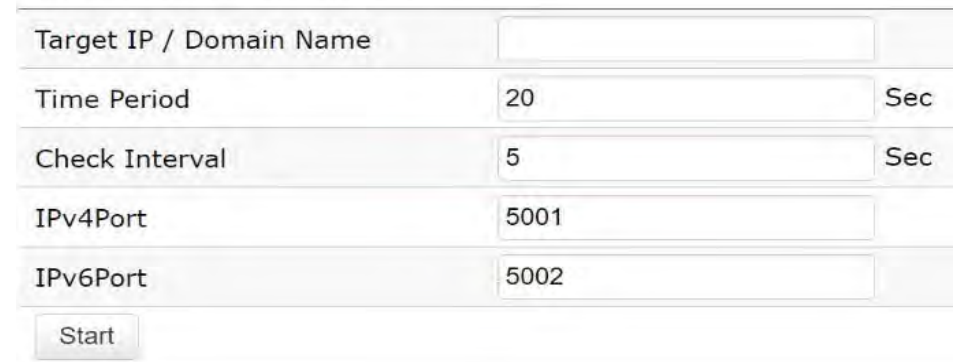

The screenshot shows a web form titled "Speed Test Parameters". It contains five input fields: "Target IP / Domain Name" (empty), "Time Period" (set to 20 Sec), "Check Interval" (set to 5 Sec), "IPv4Port" (set to 5001), and "IPv6Port" (set to 5002). Below these fields is a "Start" button.

Target IP / Domain Name: Enter an IP address or domain name you wish to implement a speed test for realizing the variance on wireless speed.

Time Period: Enter the time in seconds that you would like the test to implement for and in how many intervals.

IPv4/IPv6 Port: This Access Points uses IPv4 5001 and IPv6 60001 port for the speed test.

Start: Click start to implement speed test.

## Device Discovery

This page allows you to discover devices from network for Operation Mode, IP Address, System MAC Address and Firmware version.

Device Discovery				
Device Name	Operation Mode	IP Address	System MAC Address	Firmware Version
<input type="button" value="Scan"/>				

# Account

This page allows you to change the device username and password. By default, the username is: admin and the password is: admin. The password can contain from 0 to 12 alphanumeric characters and is case sensitive. After this changes applies, you need to login again.

## Account Settings

Administrator Username: Enter a new username for logging in to the New Name entry box.

Current Password: Enter the old password for logging in to the Old Password entry box.

New Password: Enter the new password for logging in to the New Password entry box.

Verify Password: Re-enter the new password in the Confirm Password entry box for confirmation.

Apply: Click Apply to apply the changes.

# Firmware

## Firmware Upgrade

This page allows you to upgrade the firmware of the device.

To Perform the Firmware Upgrade:

1. Click the Choose File button and navigate the OS file system to the location of the upgrade file.
2. Select the upgrade file. The name of the file will appear in the Upgrade File field.
3. Click the Upload button to commence the firmware upgrade.

Note: The device is unavailable during the Firmware upgrade process and must restart when the upgrade is completed. Any connections to or through the device will be lost.

# Backup/Restore

This page allows you to save the current device configurations. When you save your configurations, you also can reload the saved configurations into the device through the Restore Saved Settings from a file section. If extreme problems occur, or if you have set the AP incorrectly, you can use the Reset button in the Revert to Factory Default Settings section to restore all the configurations of the AP to the original default settings.

**Backup Setting:** Click Export to save the current configured settings.

**Restore New Setting:** To restore settings that have been previously backed up, click Browse, select the file, and click Restore.

**Restore to Default:** Click Reset button to restore the AP to its factory default settings.

**Backup/Restore Settings**

---

**Factory Setting**

- Backup Setting ⓘ	Export
- Restore New Setting	選擇檔案 未選擇任何檔案 Import
- Reset to Default ⓘ	Reset

---

**User Setting**

- Back Up Setting as Default	Backup
- Restore to User Default ⓘ	Restore

- **Caution:** Please write down your account number and password before saving. The user settings will now become the new default settings at the next successful login.

## User Setting

The function allows you to backup the current device configurations into the EnStationAC as the default value. If extreme problems occur, or if you have set the EnStationAC incorrectly, you can push the Reset button to revert all the configurations of the EnStationAC to the user default.

Back Up Setting as Default: Click Backup to backup **the user settings you would like to the device's memory** for the default settings.

Restore to User Default: Click Restore to restore user settings to the factory standard settings.

Note1: After setting the current settings as the default, you should click the Restore to Default on the web interface for reverting the settings into the factory default instead of pushing the reset button.

Note2: Please write down your account and password before saving. The user settings will now become the new default settings at the next successful login.

# Log

## System Log

The EnStationAC automatically logs (records) events of possible interest in its internal memory. To view the logged information, click the Log link under the System Manager menu. If there is not enough internal memory to log all events, older events are deleted from the log. When powered down or rebooted, the log will be cleared.

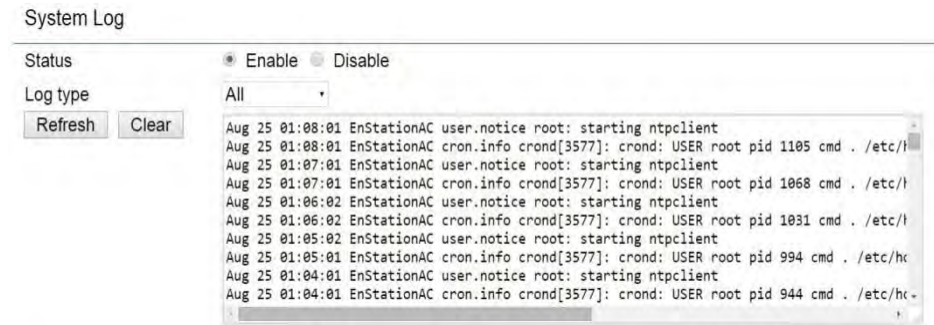

Status: Enable/Disable this function.

Traffic Log: Enable/Disable this function.

Log type: You may choose one of log types to display logs in the following window. The default log types is All.

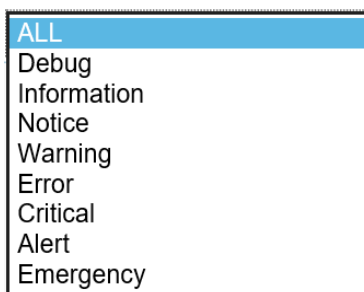

## Remote Log

This page allows you to setup the Remote Log functions for the AP/CPE.



Syslog: Enables or disables the syslog function.

Log Server IP Address: Enter the IP address of the log server.

Remote Log: Enable or disable the remote log service.

Apply: Click Apply to apply the changes.

## Logout

Click Logout in Management menu to logout.



\*The model name will be varied by different models.

Please confirm again to logout the system or not.

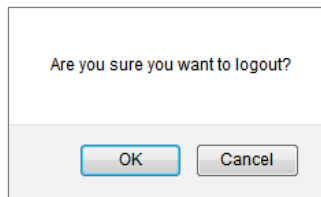

## Reset

In some circumstances, it may be required to force the device to reboot. Click on Reset to reboot or to reset the AP/CPE.



\*The model name will be varied by different models.

Once you click reset button, you will see the options for reboot or restore this AP.

Reboot the device: Click it to reboot this device.

Restore to Factory Default: Click it to reset this device to factory default setting.

Restore to User Default: Click it to reset this device to user default settings. For realizing the setting method, you may refer page 62.

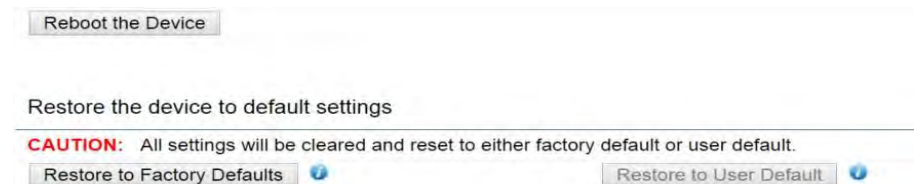



Chapter 9

# EnWiFi App



## About EnWiFi App

EnWiFi is a convenient Wi-Fi management tool for EnGenius-brand outdoor and indoor Wi-Fi devices. Configure and monitor EnGenius Wi-Fi device from a smartphone or tablet. EnWifi offers single or group device configuration and updates on your **network's latest status. You can access to EnGenius devices anytime via EnWiFi.**

## Features

### Single Configuration

Proceed single device configuration throughout EnWiFi App. The Configuration could be assisted users to fulfill settings on Wireless, Network and Systems.

### Group Configuration

Users can create a group configuration for multiple wireless access points and change between Client Bridge, WDS AP, WDS Bridge, WDS Station modes and EnGenius ERP easily.

### Device Management

Realize status of an Access Point on RF information and real time throughput on Tx and Rx ways to make maximum PtP connecting performance or remove device with weak signal.

### Discover Device

Discover EnGenius Device nearby and access to it to do management quickly.

### Connected Status Monitor

Monitor connected devices on signal level (RSSI), transmit / receive performance, and firmware version. Users can enhance device settings base on these connected information.

### Backup and Restore

Backup current configuring file and restore to other devices quickly.

# Configuring Device in EnWiFi App

Before access to device, you need to find Management SSID and connect to it first. Then you can see your device in the Device List.

## Single Configuration

Proceed Wireless Settings, Network and System Configuration to setup value on RF parameters, DHCP/Spanning Tree, and time zone for a device.

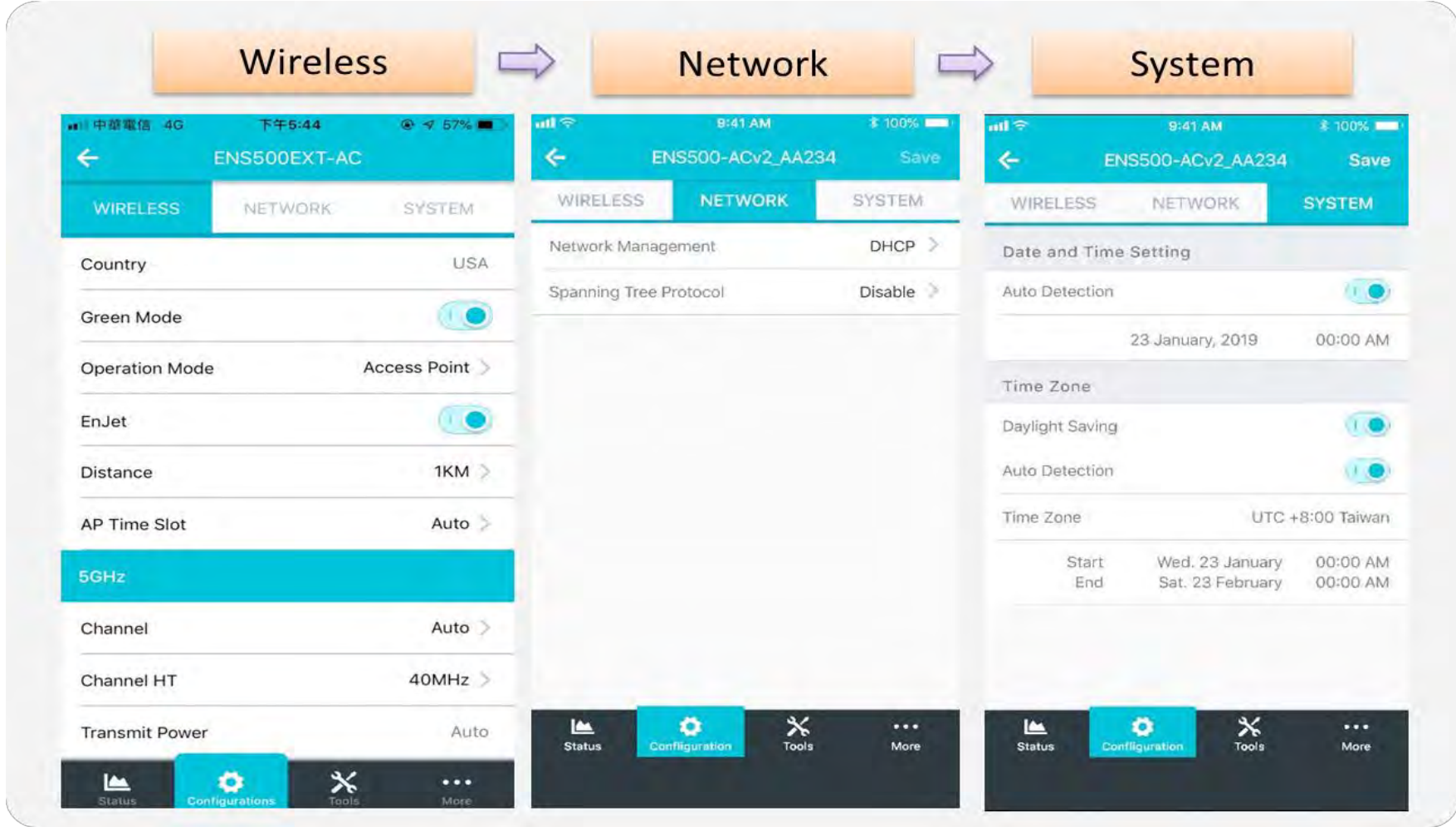

# WDS Link

Setting WDS links will assist users to setup peer-to-peer connection easily.

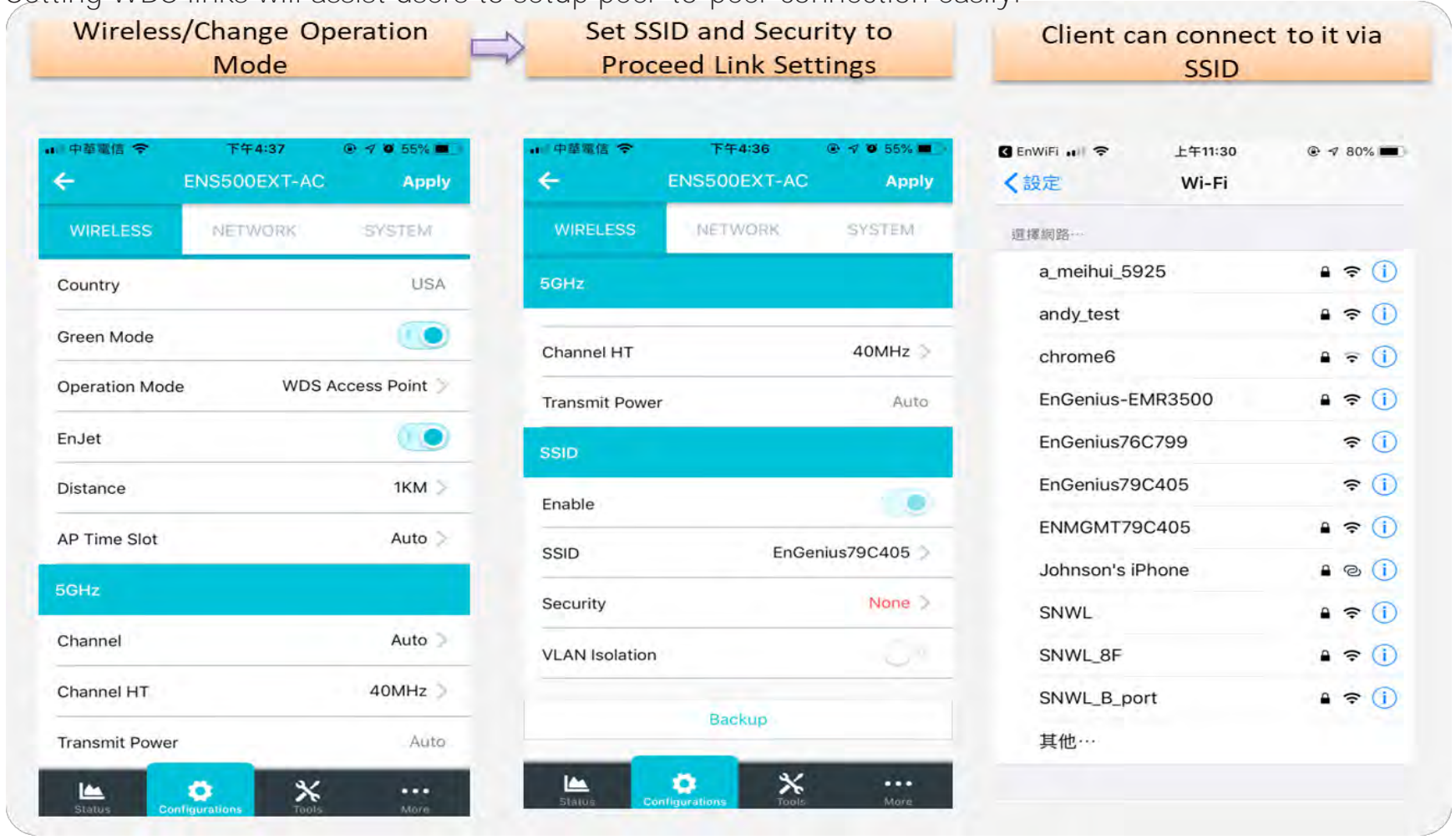

# Group Configuration

Proceed Wireless Settings including EnJet, Operation mode, distance and time slot, channel used, channel HT, Tx power and Security

The image displays a three-panel workflow for configuring a group of access points. The top navigation bar contains three orange boxes with arrows pointing right: "Select Operation Modes, EnJet and Radio Firstly.", "Check Status for Access Points", and "Proceed Wireless Setting".

- Panel 1 (Left):** "Device List" screen. It shows a list of devices under the "Connected" tab. The devices are: ENS500-AC (192.168.0.106), ENS500-AC (192.168.0.114), ENS500EXT-AC (192.168.0.113), and EnStation5-AC (192.168.0.111). Each device has an "EnJet" button. A "Group Setting" button is at the top right. A "NEXT" button is at the bottom.
- Panel 2 (Middle):** "Check Status for Access Points" screen. It shows a list of devices with their status: EnStation5-AC (Done), ENS500-AC (Done), and a list of FCC devices including ENS500-AC, ENS500EXT-AC, ENS500-AC, and EnStation5-AC, all with "EnJet" buttons. A "Done" button is at the bottom.
- Panel 3 (Right):** "Wireless Setting" screen. It shows configuration options: Country (USA), Green Mode (toggle on), Operation Mode (Access Point), EnJet (toggle on), Distance (1KM), AP Time Slot (Auto), 5GHz (selected), Channel (Auto), Channel HT (40MHz), and Transmit Power (Auto). A "NEXT" button is at the bottom.



# Group Configuration

Proceed Wireless Settings including EnJet, Operation mode, distance and time slot, channel used, channel HT, Tx power and

The image displays a three-panel workflow for configuring a group of access points. The top navigation bar contains three orange boxes with arrows pointing right: "Select Operation Modes, EnJet and Radio Firstly.", "Check Status for Access Points", and "Proceed Wireless Setting".

- Panel 1 (Left):** "Device List" screen. It shows a list of devices under the "Connected" tab. The list includes models like ENS500-AC, ENS500EXT-AC, and EnStation5-AC, each with an "EnJet" status indicator. A "Group Setting" button is visible at the top.
- Panel 2 (Middle):** "Check Status for Access Points" screen. It shows a list of devices with their status. Two devices, "EnStation5-AC" and "ENS500-AC", are marked with a green "Done" button. A "NEXT" button is at the bottom.
- Panel 3 (Right):** "Wireless Setting" screen. It shows various configuration options: Country (USA), Green Mode (toggle on), Operation Mode (Access Point), EnJet (toggle on), Distance (1KM), AP Time Slot (Auto), 5GHz (selected), Channel (Auto), Channel HT (40MHz), and Transmit Power (Auto). A "NEXT" button is at the bottom.

Proceed configuration on IP/Subnet, time Setting, and account/password under a group.

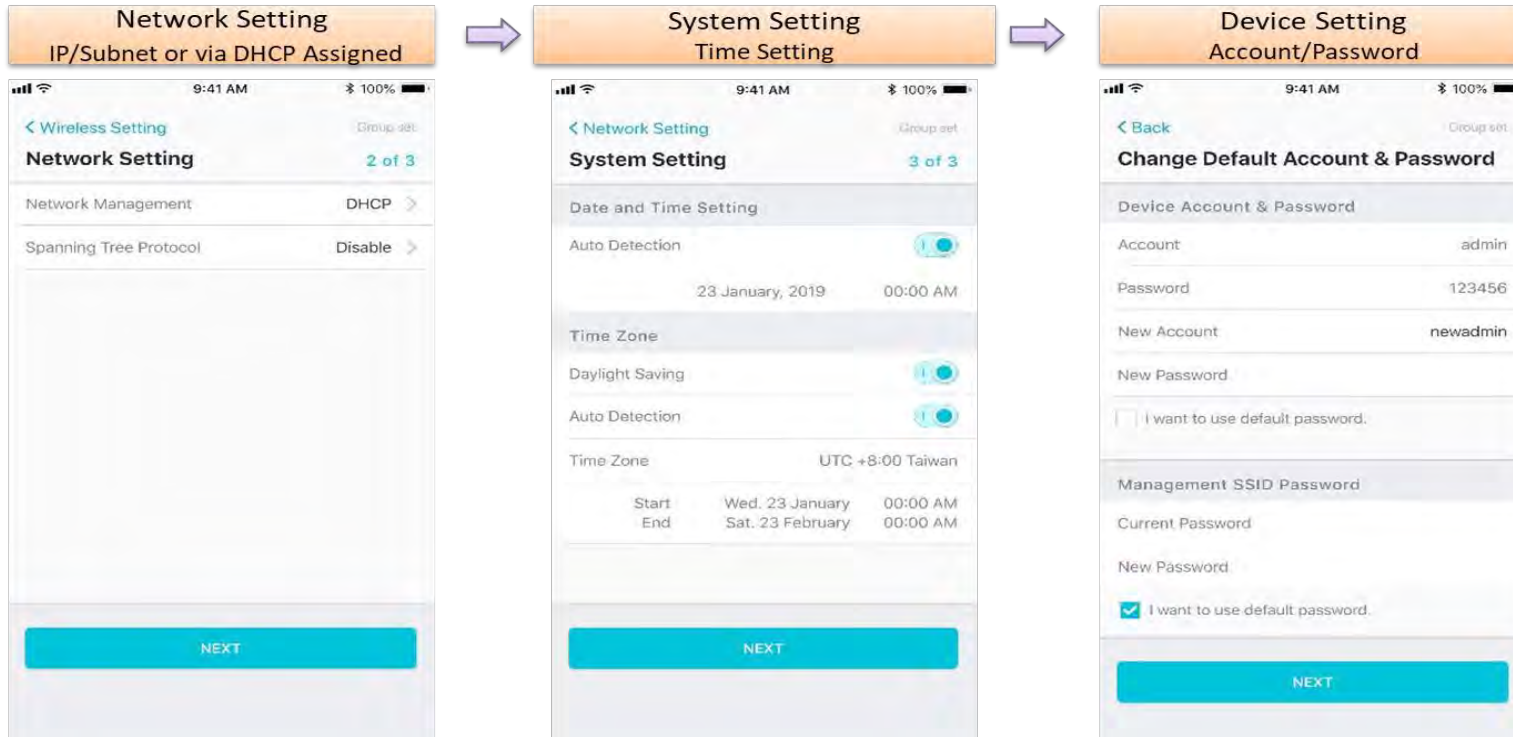

You also can use EnWiFi App to proceed connection from Client Bridge mode devices to an Access Point mode device.

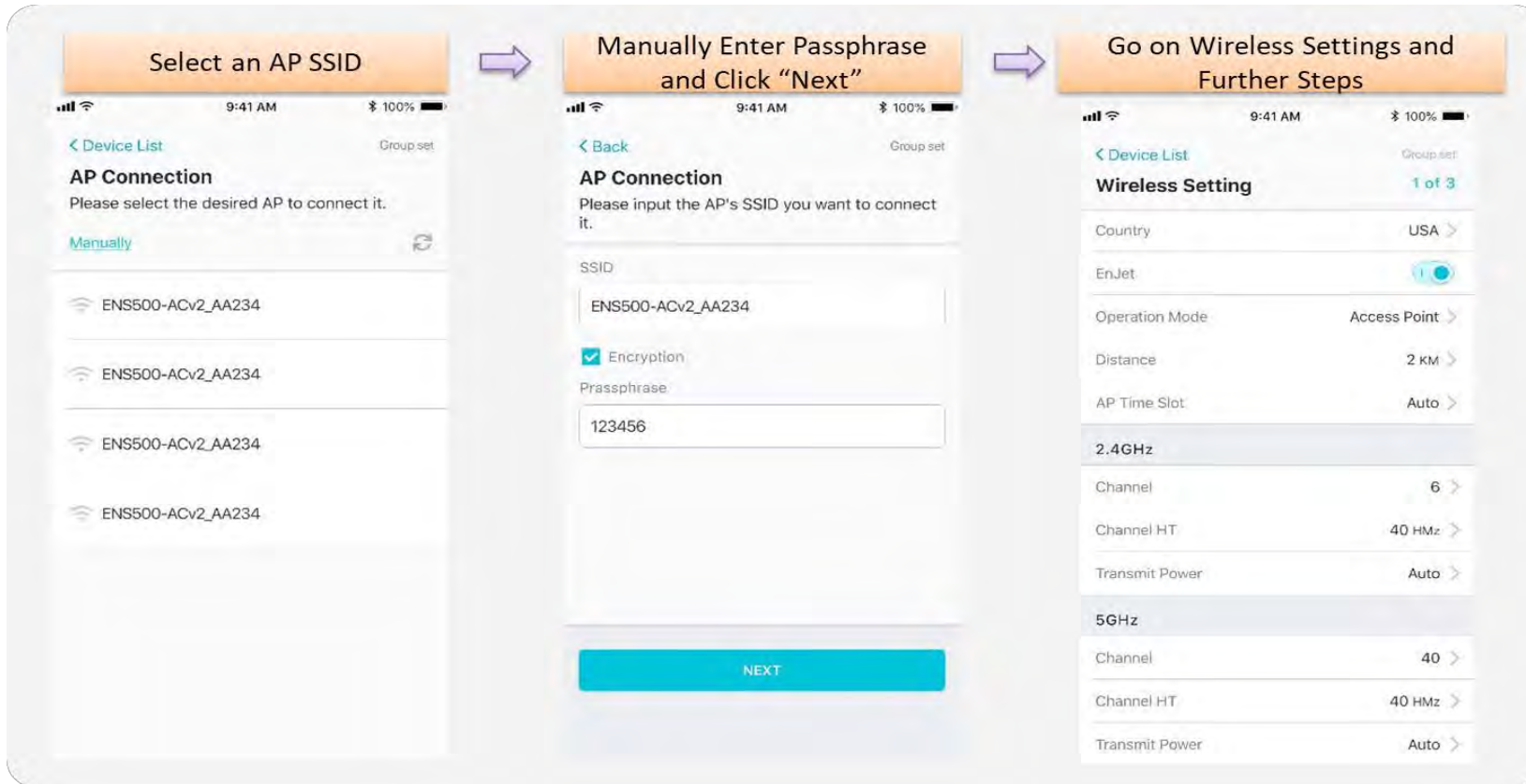



You also can set Operation mode to WDS AP mode and let WDS STA devices connect to this WDS AP mode device.

The image displays two sets of screenshots from a mobile application, illustrating the configuration process for WDS (Wireless Distribution System) modes.

**Top Set: WDS AP Configuration**

- Step 1:** "Select operation mode to WDS AP and choose AP". The screen shows "Operation Mode" set to "WDS AP", "EnJet Function Supported" is enabled, and "Radio" is set to "5GHz". An "Apply" button is visible.
- Step 2:** "Configure wireless Setting". The screen shows "Wireless Setting" for "WDS AP". Settings include: Country (USA), EnJet (enabled), Operation Mode (WDS AP), Distance (2 KM), AP Time Slot (Auto). Under "2.4GHz", Channel is 6, Channel HT is 40 Hz, and Transmit Power is Auto. Under "5GHz", Channel is 40, Channel HT is 40 Hz, and Transmit Power is Auto.

**Bottom Set: WDS STA Configuration**

- Step 1:** "Select operation mode to WDS STA and choose AP to connect". The screen shows "Operation Mode" set to "WDS STA", "EnJet Function Supported" is enabled, and "Radio" is set to "5GHz". An "Apply" button is visible.
- Step 2:** "Configure wireless Setting". The screen shows "AP Connection" with the instruction "Please select the desired AP to connect it." and a "Refresh" button. A list of APs is shown: EnGenius-79F2CD, EnGenius79F2CD\_1, EnGenius5E0DEC, EMR3500, UAP\_ACSHD, SNWL\_B\_port, SNWL, EnGenius343B3F, EPG\_NTC5, 5912SSID5\_1, and EnGenius7F.
- Step 3:** "Configure wireless Setting". The screen shows "Wireless Setting" for "WDS STA". Settings include: Country (USA), EnJet (enabled), Green Mode (enabled), Transmit Power (Auto), Distance (2 KM), and Station Priority (High). A "NEXT" button is visible at the bottom.

# Discover Device

Discover and Access to other EnGenius devices to manage their status.

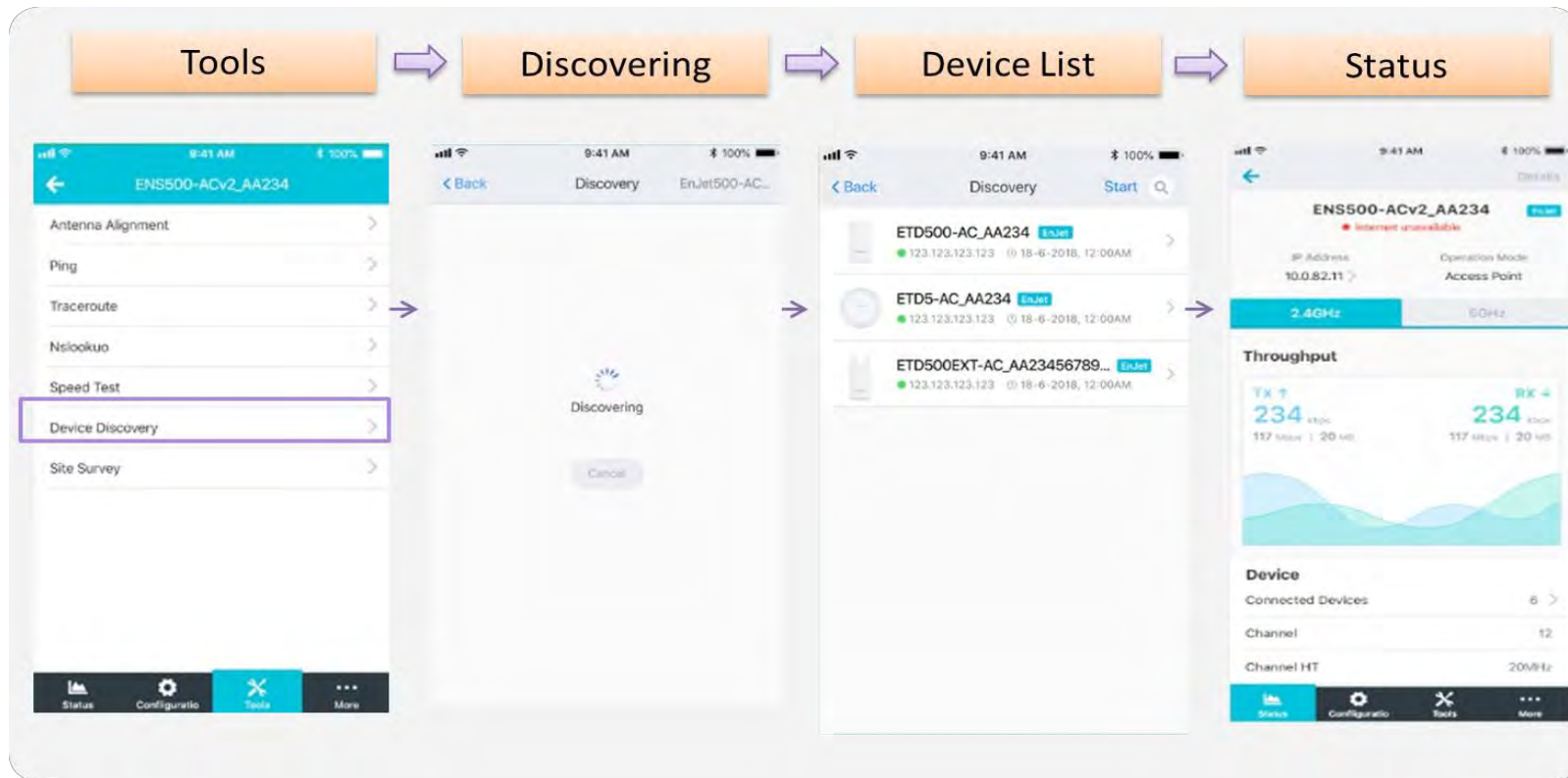

## Monitor & Management

Monitor clients connected status. Base on this information to adjust configuration or press kick out to remove device if the signal is weak .

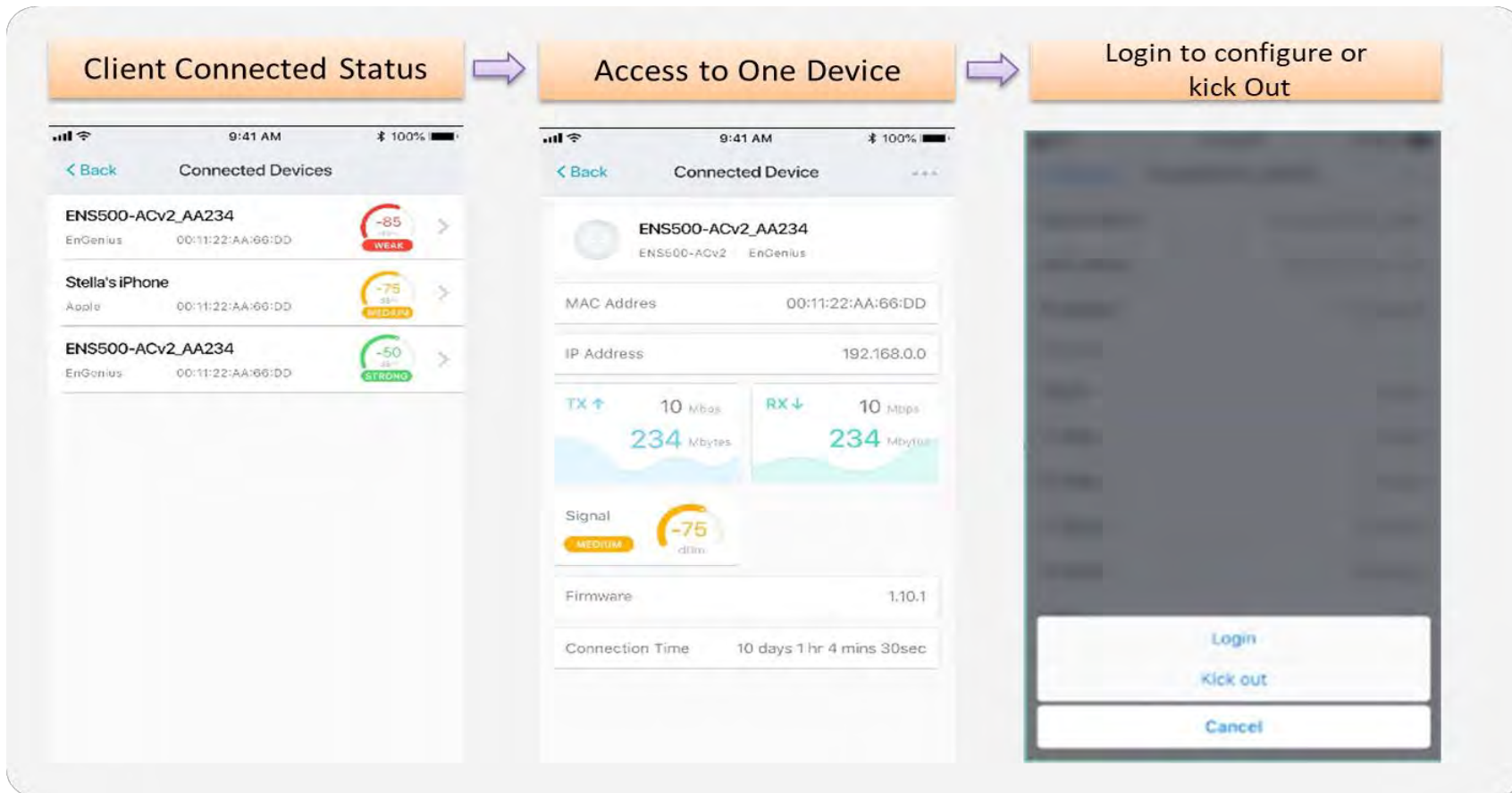

# Backup

Backup current settings as a configuration file to apply to other devices quickly.

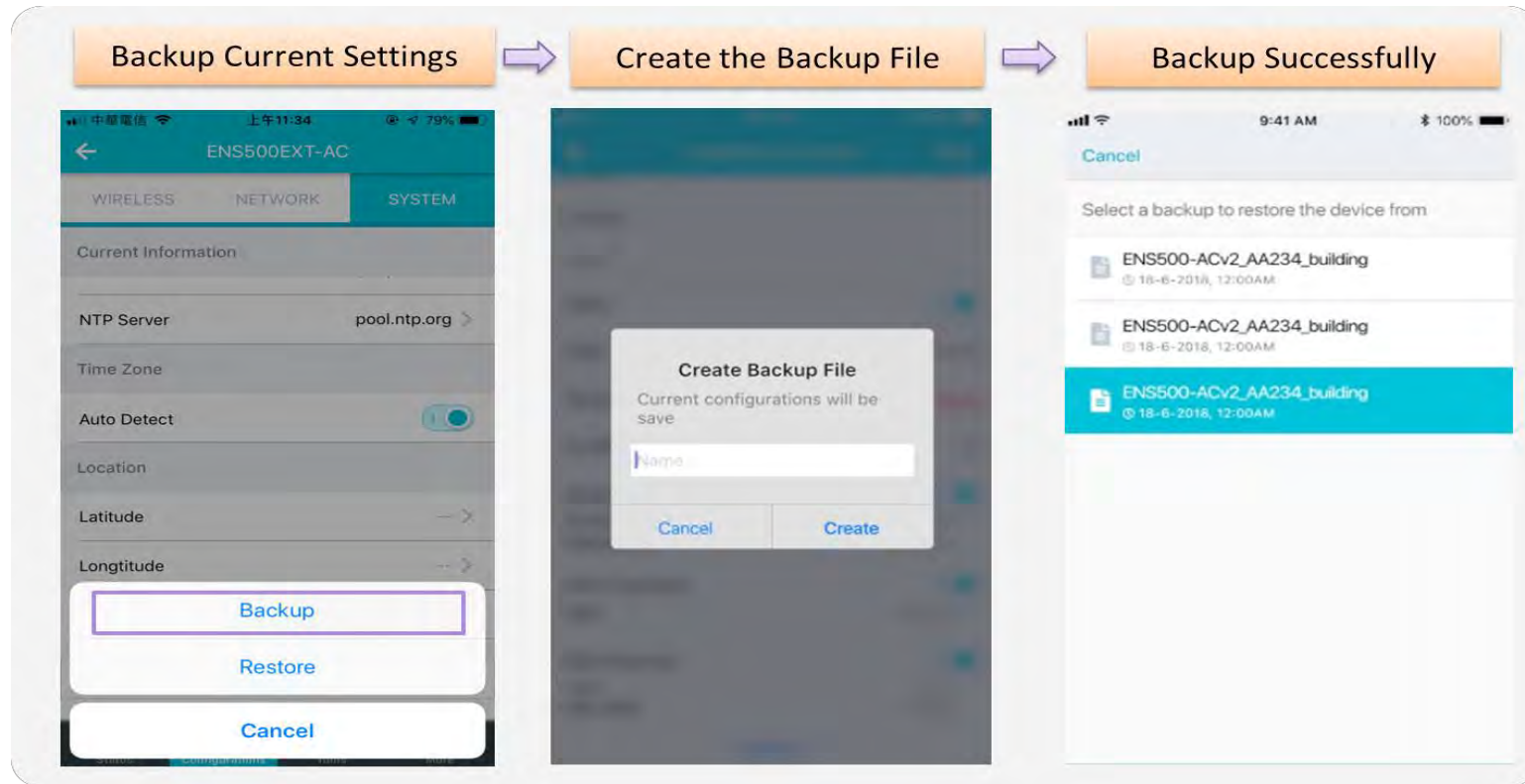

# Restore

Choose backup file to restore other devices so that they can have the same configuration quickly.

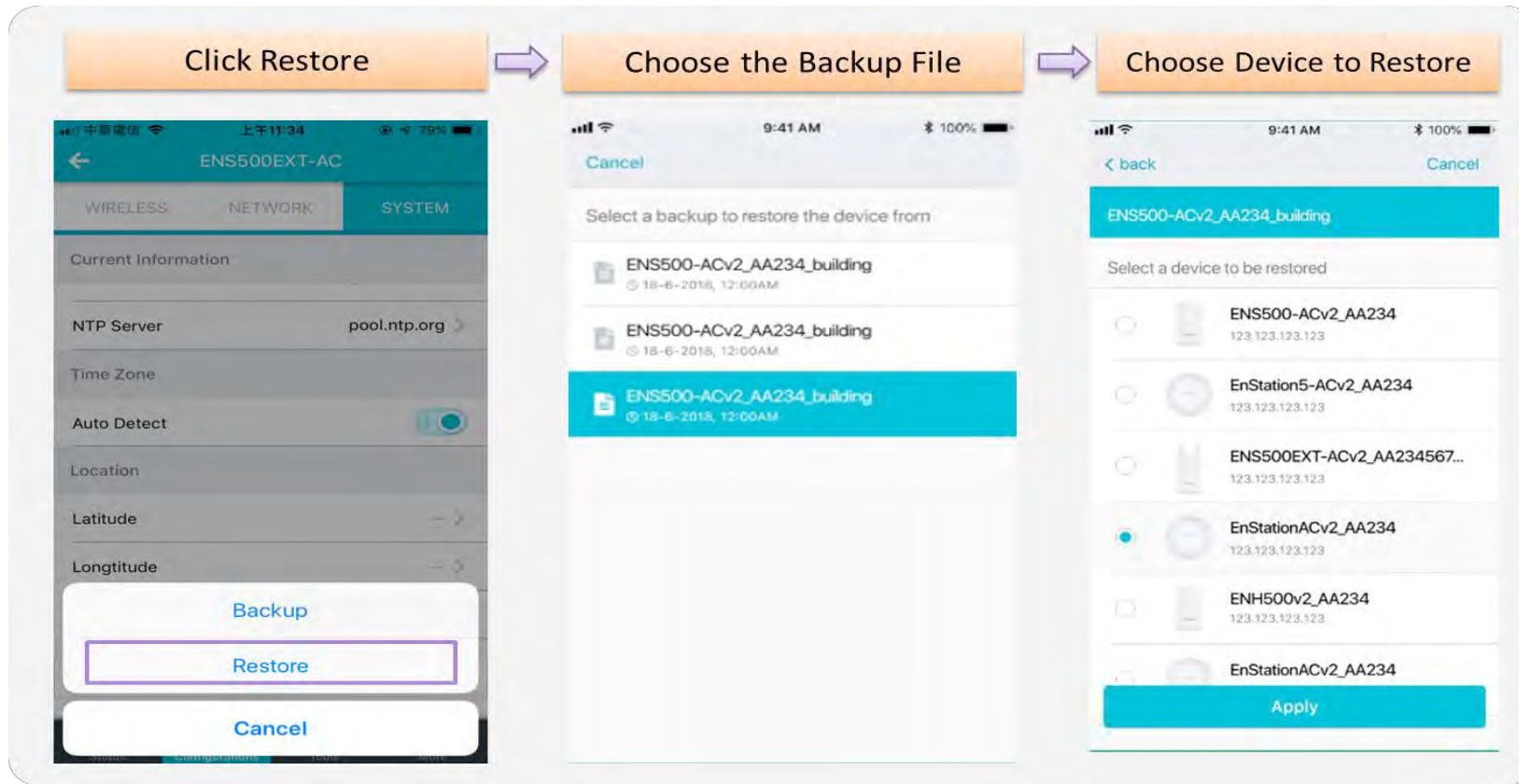

# Appendix



# Appendix A - Federal Communication Commission Interference Statement

This device complies with Part 15 of the FCC Rules. Operation is subject to the following two conditions:

(1) This device may not cause harmful interference, and (2) this device must accept any interference received, including interference that may cause undesired operation.

This equipment has been tested and found to comply with the limits for a Class B digital device, pursuant to Part 15 of the FCC Rules. These limits are designed to provide reasonable protection against harmful interference in a residential installation. This equipment generates, uses and can radiate radio frequency energy and, if not installed and used in accordance with the instructions, may cause harmful interference to radio communications. However, there is no guarantee that interference will not occur in a particular installation. If this equipment does cause harmful interference to radio or television reception, which can be determined by turning the equipment off and on, the user is encouraged to try to correct the interference by one of the following measures:

- Reorient or relocate the receiving antenna.
- Increase the separation between the equipment and receiver.
- Connect the equipment into an outlet on a circuit different from that to which the receiver is connected.
- Consult the dealer or an experienced radio/TV technician for help.

FCC Caution: Any changes or modifications not expressly approved by the party responsible for compliance could void the user's authority to operate this equipment.

This transmitter must not be co-located or operating in conjunction with any other antenna or transmitter.

## **Radiation Exposure Statement:**

This equipment complies with FCC radiation exposure limits set forth for an uncontrolled environment. This equipment should be installed and operated with minimum distance 20cm between the radiator & your body.

# Professional installation instruction

## 1. Installation personal

This product is designed for specific application and needs to be installed by a qualified personal who has RF and related rule knowledge. The general user shall not attempt to install or change the setting.

## 2. Installation location

The product shall be installed at a location where the radiating antenna can be kept 20cm from nearby person in normal operation condition to meet regulatory RF exposure requirement.

## 3. External antenna

Use only the antennas which have been approved by the applicant. The non-approved antenna(s) may produce unwanted spurious or excessive RF transmitting power which may lead to the violation of FCC/IC limit and is prohibited.

## 4. Installation procedure

**Please refer to user's manual for the detail.**

## 5. Warning

Please carefully select the installation position and make sure that the final output power does not exceed the limit set force in relevant rules. The violation of the rule could lead to serious federal penalty.



## **Appendix B - Industry Canada statement:**

**This device complies with ISED's licence-exempt RSSs.** Operation is subject to the following two conditions:

- (1) This device may not cause harmful interference, and
- (2) this device must accept any interference received, including interference that may cause undesired operation.

**Le présent appareil est conforme aux CNR d'ISED applicables aux appareils radio exempts de licence.**

**L'exploitation est autorisée aux deux** conditions suivantes :

- (1) le dispositif ne doit pas produire de brouillage préjudiciable, et
- (2) ce dispositif doit accepter tout brouillage reçu, y compris un brouillage susceptible de provoquer un fonctionnement indésirable.

### **Radiation Exposure Statement:**

This equipment complies with ISED radiation exposure limits set forth for an uncontrolled environment. This equipment should be installed and operated with greater than 20cm between the radiator & your body.

### **Déclaration d'exposition aux radiations:**

Cet équipement est conforme aux limites d'exposition aux rayonnements ISED établies pour un environnement non contrôlé. Cet équipement doit être installé et utilisé à plus de 20 cm entre le radiateur et votre corps.

# Instructions d'installation professionnelle

## 1. Installation

Ce produit est destiné à un usage spécifique et doit être installé par un personnel qualifié maîtrisant les radiofréquences et les règles s'y rapportant. L'installation et les réglages ne doivent pas être modifiés par l'utilisateur final.

## 2. Emplacement d'installation

En usage normal, afin de respecter les exigences réglementaires concernant l'exposition aux radiofréquences, ce produit doit être installé de façon à respecter une distance de 20cm entre l'antenne émettrice et les personnes.

## 3. Antenne externe.

Utiliser uniquement les antennes approuvées par le fabricant. L'utilisation d'autres antennes peut conduire à un niveau de rayonnement essentiel ou non essentiel dépassant les niveaux limites définis par FCC/IC, ce qui est interdit.

## 4. Procédure d'installation

Consulter le manuel d'utilisation.

## 5. Avertissement

Choisir avec soin la position d'installation et s'assurer que la puissance de sortie ne dépasse pas les limites en vigueur. La violation de cette règle peut conduire à de sérieuses pénalités fédérales.