

## Scavenger Transceiver Module STM 300 / STM 300C / STM 300U

June 7<sup>th</sup>, 2013



**Observe precautions! Electrostatic sensitive devices!**

Patent protected:

WO98/36395, DE 100 25 561, DE 101 50 128,  
WO 2004/051591, DE 103 01 678 A1, DE 10309334,  
WO 04/109236, WO 05/096482, WO 02/095707,  
US 6,747,573, US 7,019,241

## REVISION HISTORY

The following major modifications and improvements have been made to the first version of this document:

No	Major Changes
1.01	Tape running direction added in 3.8
1.10	Application note for multiple digital inputs with WAKE functionality added.
1.20	Error corrected in 3.5.1. and 4.1: Maximum gain of external antenna at 50 Ohm output RF_50 is 0 dBi!
1.25	Charging circuit in 3.1 corrected; remarks added regarding use of IOVDD in 2.3. Parameters of A/D converter corrected and specified in more detail in 2.3.2
1.26	Optional resolution at ADIO0, ADIO1, ADIO2 corrected in 2.3. Detailed description in 2.9.1 was correct!
1.30	New improved application note in 3.1, which avoids deep discharge of the long term storage.
1.31	Updated data on conducted output power in 1.2; improved layout recommendations in 3.6
1.32	Antenna recommendations removed and referred to external application note AN102, and AN105; Maximum Rating for IOVDD modified (IOVDD may now exceed VDD); Chapter "Related Documents" added. Figure added in 3.3.1; parameters for antenna requirements relaxed in 4.5.1.
1.33	Added STM 300U (902.875 MHz), new product image
1.34	Updated Agency certifications according to FCC / IC requirements
1.35	Mitsubishi Materials Chip Antenna added to limited modular approval

**Published by EnOcean GmbH, Kolpingring 18a, 82041 Oberhaching, Germany  
[www.enocean.com](http://www.enocean.com), [info@enocean.com](mailto:info@enocean.com), phone +49 (89) 6734 6890**

© EnOcean GmbH  
 All Rights Reserved

### Important!

This information describes the type of component and shall not be considered as assured characteristics. No responsibility is assumed for possible omissions or inaccuracies. Circuitry and specifications are subject to change without notice. For the latest product specifications, refer to the EnOcean website: <http://www.enocean.com>.

As far as patents or other rights of third parties are concerned, liability is only assumed for modules, not for the described applications, processes and circuits.

EnOcean does not assume responsibility for use of modules described and limits its liability to the replacement of modules determined to be defective due to workmanship. Devices or systems containing RF components must meet the essential requirements of the local legal authorities.

The modules must not be used in any relation with equipment that supports, directly or indirectly, human health or life or with applications that can result in danger for people, animals or real value.

Components of the modules are considered and should be disposed of as hazardous waste. Local government regulations are to be observed.

Packing: Please use the recycling operators known to you.

## TABLE OF CONTENT

1	MODULE VARIANTS AND RELATED DOCUMENTS .....	4
2	GENERAL DESCRIPTION .....	4
	2.1 Basic functionality .....	4
	2.2 Technical data .....	5
	2.3 Physical dimensions .....	6
	2.4 Environmental conditions .....	6
	2.5 Ordering Information .....	6
3	FUNCTIONAL DESCRIPTION .....	8
	3.1 Simplified firmware flow chart and block diagram .....	8
	3.2 Hardware pin out.....	9
	3.3 Pin description and operational characteristics.....	10
	3.3.1 GPIO supply voltage .....	12
	3.3.2 Analog and digital inputs .....	13
	3.4 Absolute maximum ratings (non operating) .....	14
	3.5 Maximum ratings (operating).....	14
	3.6 Power management and voltage regulators .....	14
	3.7 Charge control output (CCO).....	15
	3.8 Configuration .....	16
	3.8.1 Configuration via pins .....	16
	3.8.2 Configuration via programming interface .....	17
	3.9 Radio telegram.....	18
	3.9.1 Normal operation.....	18
	3.9.2 Teach-in telegram .....	19
	3.10 Transmit timing.....	19
	3.11 Energy consumption .....	20
4	APPLICATIONS INFORMATION.....	21
	4.1 How to connect an energy harvester and energy storage.....	21
	4.2 Using the SCO pin .....	23
	4.3 Using the WAKE pins.....	23
	4.4 Using RVDD .....	24
	4.5 Antenna options STM 300x .....	25
	4.5.1 Overview .....	25
	4.5.2 Whip antenna.....	25
	4.5.3 Helical antenna (Supplier: EnOcean) .....	26
	4.5.4 Chip antenna (supplier: Mitsubishi Material, Type AM11DG-ST01) .....	27
	4.6 Positioning of the whip antenna.....	28
	4.7 Recommendations for laying a whip antenna.....	29
	4.8 Layout recommendations for foot pattern .....	30
	4.9 Soldering information.....	34
	4.10 Tape & Reel specification .....	35
	4.11 Transmission range.....	36
5	AGENCY CERTIFICATIONS .....	37
	5.1 CE approval .....	37
	5.2 FCC (United States) Certification .....	38
	5.3 IC (Industry Canada) Certification .....	40
	5.4 FCC Regulatory Statements.....	41
	5.5 Industry Canada Regulatory Statements .....	42

## 1 MODULE VARIANTS AND RELATED DOCUMENTS

The STM300 Scavenger Transceiver Module is available in several operating frequency variations:

STM 300: 868.350 MHz  
STM 300C: 315.000 MHz  
STM 300U: 902.875 MHz

Inside this manual the term STM 300x can be used interchangeably for any of the above frequency.

This document describes operation of STM 300x modules with their built-in firmware. If you want to write own firmware running on the integrated micro controller or need more detailed information on the Dolphin core please also refer to:

- [Dolphin Core Description](#)
- [Dolphin API Documentation](#)

In addition we recommend following our [application notes](#), in particular:

- AN102: Antenna Basics – Basic Antenna Design Considerations for EnOcean based Products
- AN105: 315 MHZ Internal Antenna Design – Considerations for EnOcean based Products
- AN207: ECS 300/310 Solar Panel - Design Considerations
- AN208: Energy Storage – Design Considerations
- AN209: STM 300 THERMO OR BATTERY POWERED – Power Supply Alternatives to Solar Panel

## 2 GENERAL DESCRIPTION

### 2.1 Basic functionality

The extremely power saving RF transmitter module STM 300 of EnOcean enables the realization of wireless and maintenance free sensors and actuators such as room operating panels, motion sensors or valve actuators for heating control.

Power supply is provided by an external energy harvester, e.g. a small solar cell (e.g. EnOcean ECS 3x0) or a thermal harvester. An energy storage device can be connected externally to bridge periods with no supply from the energy harvester. A voltage limiter avoids damaging of the module when the supply from the energy harvester gets too high. The module provides a user configurable cyclic wake up. After wake up a radio telegram (input data, unique 32 bit sensor ID, checksum) will be transmitted in case of a change of any digital input value



compared to the last sending or in case of a significant change of measured analogue values (different input sensitivities can be selected). In case of no relevant input change a redundant retransmission signal is sent after a user configurable number of wake-ups to announce all current values. In addition a wake up can be triggered externally.

### Features with built-in firmware

- 3 A/D converter inputs
- 4 digital inputs
- Configurable wake-up and transmission cycle
- Wake-up via Wake pins
- Voltage limiter
- Threshold detector
- Application notes for calculation of energy budgets and management of external energy storages

### Product variants

- STM 300 / STM 300C / STM 300U

### Features accessible via API

Using the Dolphin API library it is possible to write custom firmware for the module. STM 300/C/U is in-system programmable. The API provides:

- Integrated 16 MHz 8051 CPU with 32 KB FLASH and 2 kB SRAM
- Receiver functionality
- Various power down and sleep modes down to typ. 0.2  $\mu$ A current consumption
- Up to 16 configurable I/Os
- 10 bit ADC, 8 bit DAC

## 2.2 Technical data

<b>Antenna</b>	External whip or 50 $\Omega$ antenna mountable
<b>Frequency</b>	STM 300: 868.300MHz (ASK) <sup>1)</sup> STM 300C: 315.000MHz (ASK) <sup>1)</sup> STM 300U: 902.875 MHz (FSK)
<b>Data rate</b>	125 kbps
<b>Receiver Sensitivity (at 25 °C)</b> only via API	typ. -96 dBm <sup>2)</sup> (868.300 MHz) typ. -98 dBm <sup>2)</sup> (315.000 MHz) typ. -98 dBm <sup>2)</sup> (902.875 MHz)
<b>Conducted Output Power</b> <b>@50<math>\Omega</math> min / typ / max</b>	STM 300: 3.0 dBm / 5.7 dBm / 7.0 dBm STM 300C: 5.5 dBm / 7.5 dBm / 9.5 dBm STM 300U: -1 dBm / 1 dBm / 3dBm <sup>3)</sup>
<b>Power Supply</b>	2.1 V–4.5 V, 2.6 V needed for start-up
<b>Current Consumption</b>	Deep Sleep mode : typ. 0.2 $\mu$ A Transmit mode: typ. 24 mA, max. 33 mA Receive mode (via API only): typ. 33 mA, max. 43 mA
<b>Input Channels</b>	4x digital input, 2x WAKE input , 3x analog input Resolution: 3x 8 bit or 1x 10 bit, 1x 8 bit, 1x 6 bit

**Radio Regulations**

R&TTE EN 300 220 (STM 300)  
 FCC CFR-47 Part 15 (STM 300C / STM 300U)

- 1) according to ISO/IEC 14543-3-10
- 2) @ 0.1% telegram error rate (based on transmitted sub-telegrams)
- 3) using +1dBm (V 1.13) power settings which comply to limited modular approval

**2.3 Physical dimensions**

**PCB dimensions**

STM 300/C/U: 22 x 19 x 3.1 mm

**Weight**

1.9 g

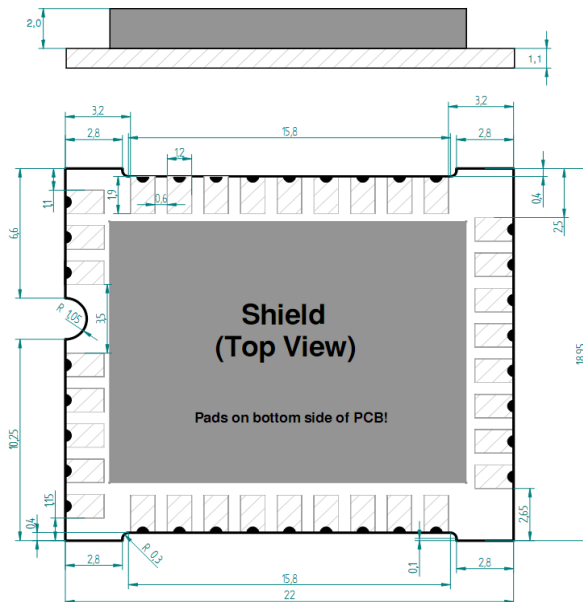

STM 300/C/U (pads on bottom side of PCB!)

Unless otherwise specified dimensions are in mm.

Tolerances:  
 PCB outline dimensions ±0.2 mm  
 All other tolerances ±0.1 mm

**2.4 Environmental conditions**

<b>Operating temperature</b>	-25 °C ... +85 °C
<b>Storage temperature</b>	-40 °C ... +85 °C
<b>Storage temperature in tape &amp; reel package</b>	-20 °C ... +50 °C
<b>Humidity</b>	0% ... 93% r.h., non-condensing

**2.5 Ordering Information**

STM 300 / STM 300C / STM 300U

Type	Ordering Code	Frequency
<b>STM 300</b>	<b>S3001-D300</b>	<b>868.300 MHz</b>
<b>STM 300C</b>	<b>S3031-D300</b>	<b>315.000 MHz</b>
<b>STM 300U</b>	<b>S3051-D300</b>	<b>902.875 MHz</b>

Suited solar cells (for technical details please refer to the ECS3x0 data sheet):

Type	Ordering Code	Size
<b>ECS 300</b>	<b>S3005-D305</b>	<b>35.0 × 12.8 × 1.1 mm</b>
<b>ECS 310</b>	<b>S3005-D310</b>	<b>50.0 × 20.0 × 1.1 mm</b>

### 3 FUNCTIONAL DESCRIPTION

#### 3.1 Simplified firmware flow chart and block diagram

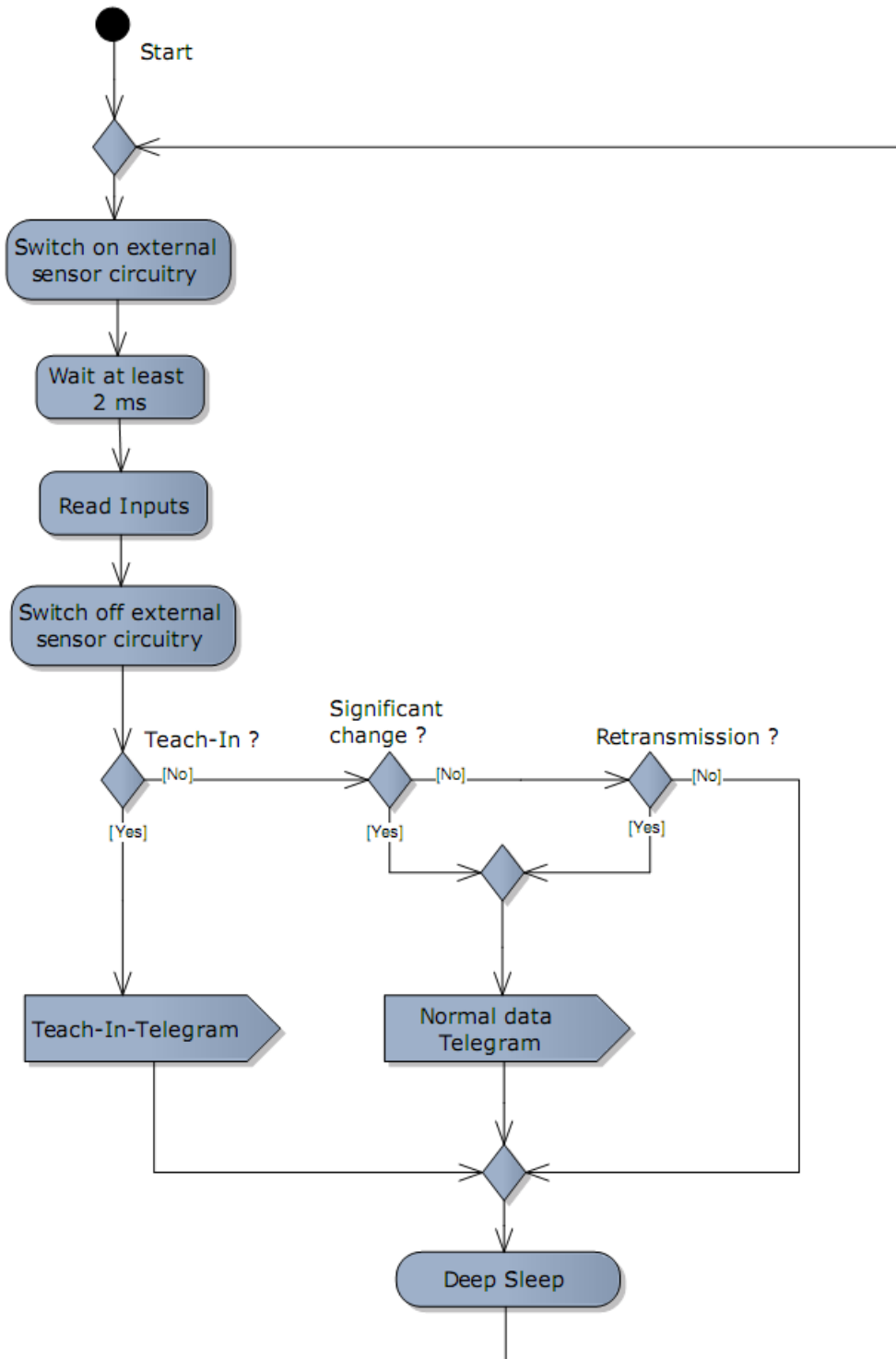



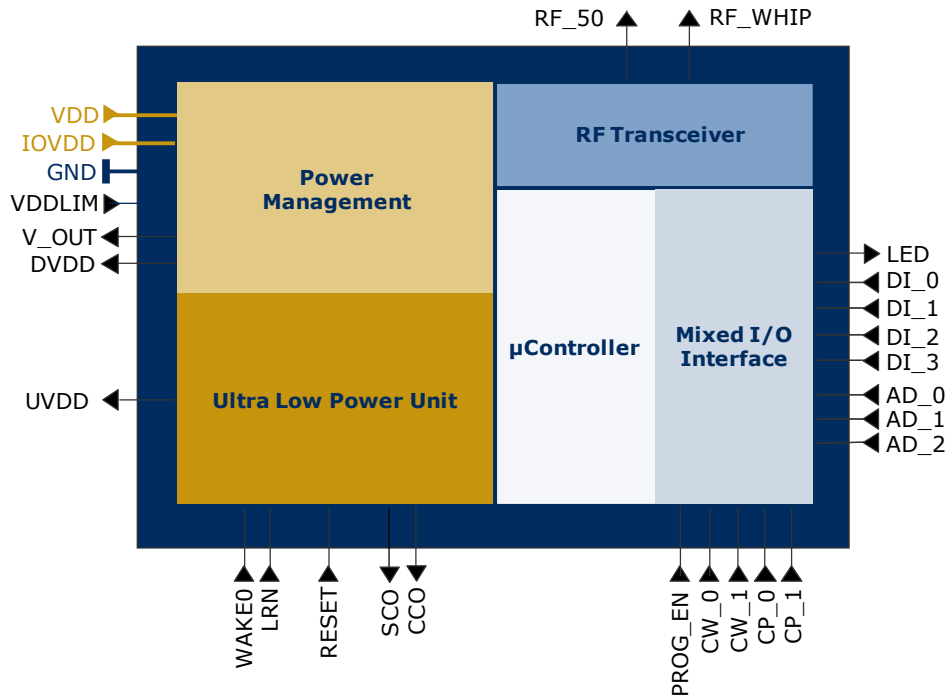

### 3.2 Hardware pin out

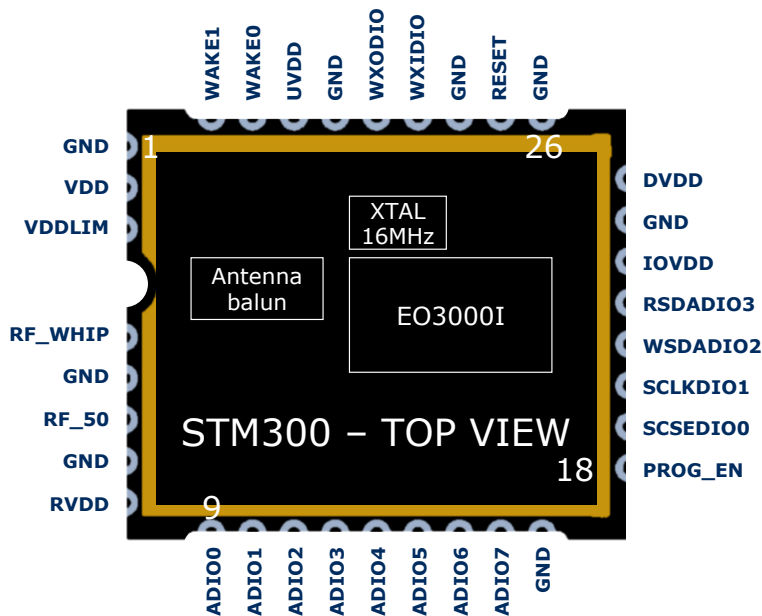

The figure above shows the pin out of the STM 300 hardware. The pins are named according to the naming of the EO3000I chip to simplify usage of the DOLPHIN API. The table in section 3.3 shows the translation of hardware pins to a naming that fits the functionality of the built-in firmware. When writing own firmware based on the DOLPHIN API please refer to the Dolphin Core Description and use this manual only for information

regarding the module hardware, such as pin out, layout recommendations, charging circuitry, antenna options, and approvals.

### 3.3 Pin description and operational characteristics

STM 300 Hardware Symbol	STM 300 pin #	STM 300 Firmware Symbol	Function	Characteristics
GND	1, 5, 7, 17, 24, 26, 28, 31	GND	Ground connection	Must be connected to GND
VDD	2	VDD	Supply voltage	2.1 V – 4.5 V; Start-up voltage: 2.6 V Maximum ripple: see 3.6
RVDD	8	V_OUT	RF supply voltage regulator output	1.8 V. Output current: max. 10 mA. See 4.4! Supply for external circuitry, available while not in deep sleep mode.
DVDD	25	DVDD	Digital supply voltage regulator output	1.8 V. Output current: max. 5 mA Supply for external circuitry, available while not in deep sleep mode.
UVDD	32	UVDD	Ultra low power supply voltage regulator output	Not for supply of external circuitry! For use with WAKE pins, see section 4.3. Max. 1 $\mu$ A output current!
VDDLIM	3	VDDLIM	Supply voltage limiter input	Limitation voltage: 4.5 V Maximum shunting current: 50 mA
IOVDD	23	IOVDD	GPIO supply voltage	Must be connected to desired interface supply voltage as specified in 3.5, e.g. to DVDD. See also 3.3.1
RESET	27	RESET	Reset input Programming I/F	Active high reset (1.8 V) Connect external 10 k $\Omega$ pull-down.
PROG_EN	18	PROG_EN	Programming I/F	HIGH: programming mode active LOW: operating mode Digital input, connect external 10 k $\Omega$ pull-down.
ADIO0	9	AD_0	Analog input	Input read $\sim$ 2 ms after wake-up. Resolution 8 bit (default) or 10 bit. See also 3.3.2.
ADIO1	10	AD_1	Analog input	Input read $\sim$ 2 ms after wake-up. Resolution 8 bit (default) or 6 bit. See also 3.3.2.
ADIO2	11	AD_2	Analog input	Input read $\sim$ 2 ms after wake-up. Resolution 8 bit. See also 3.3.2.

ADIO3	12	DI_0	Digital input	Input read ~2 ms after wake-up. See also 3.3.2.
ADIO4	13	DI_1	Digital input	Input read ~2 ms after wake-up. See also 3.3.2.
ADIO5	14	DI_2	Digital input	Input read ~2 ms after wake-up. See also 3.3.2.
ADIO6	15	DI_3	Digital input	Input read ~2 ms after wake-up. See also 3.3.2.
ADIO7	16	LED	Transmission indicator LED	Max. output current: 2 mA @ IOVDD=3.3 V 0.65 mA @ IOVDD=1.8 V
			Programming I/F	
SCSEDI00	19	CW_1	Encoding input for wake-up cycle	Leave open or connect to GND
			Programming I/F	
SCLKDIO1	20	CW_0	Encoding input for wake-up cycle	Leave open or connect to GND
			Programming I/F	
WSDADIO2	21	CP_1	Encoding input for retransmission	Leave open or connect to GND
			Programming I/F	
RSDADIO3	22	CP_0	Encoding input for retransmission	Leave open or connect to GND
			Programming I/F	
WXIDIO	29	SCO	Sensor control	Digital output, max. current 15 $\mu$ A HIGH ~x ms before analog inputs are read (x=0...508 ms; default 2 ms.) LOW at wake-up and after reading of analog inputs Polarity can be inverted, delay time can be programmed, see 3.8.2.
WXODIO	30	CCO	Charge control	Max output current 15 $\mu$ A See 3.7 for description of behaviour.
WAKE0	33	WAKE0	Wake input	Change of logic state leads to wake-up and transmission of a telegram. See also 4.3.
WAKE1	34	LRN	LRN input	Change of logic state to LOW leads to wake-up and transmission of teach-in telegram if a manufacturer code is programmed. See also 3.9.2 and 4.3.
RF_WHIP	4	RF_WHIP	RF output	Output for whip antenna
RF_50	6	RF_50	RF output	50 Ohm output for external antenna

### 3.3.1 GPIO supply voltage

For digital communication with other circuitry (peripherals) the digital I/O configured pins of the mixed signal sensor interface (ADIO0 to ADIO7) and the pins of the programming interface (SCSEDIO0, SCLKDIO1, WSDADIO2, RSDADIO3) may be operated from supply voltages different from DVDD. Therefore an interface supply voltage pin IOVDD is available which can be connected either to DVDD or to an external supply within the tolerated voltage range of IOVDD. Please note that the wristwatch XTAL I/Os WXIDIO and WXODIO are always supplied from UVDD.



If DVDD=0 V (e.g. in any sleep mode or if VDD<VOFF) and IOVDD is supplied, there may be unpredictable and varying current from IOVDD caused by internal floating nodes. It must be taken care that the current into IOVDD does not exceed 10 mA while DVDD=0 V.

If DVDD=0 V and IOVDD is not supplied, do not apply voltage to any above mentioned pin. This may lead to unpredictable malfunction of the device.



For I/O pins configured as analog pins the IOVDD voltage level is not relevant! However it is important to connect IOVDD to a supply voltage as specified in 3.5.

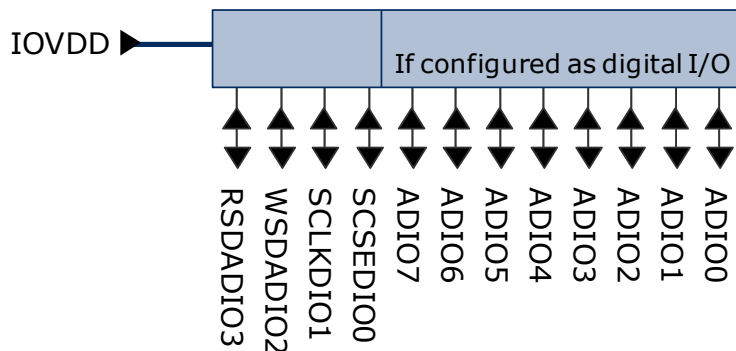

### 3.3.2 Analog and digital inputs

Parameter	Conditions / Notes	Min	Typ	Max	Units
<b>Analog Input Mode</b>					
Measurement range	Single ended Internal reference RVDD/2	0.067		RVDD-0.12	V
Input coupling			DC		
Measurement bandwidth <sup>1</sup>			62.5		kHz
Input impedance	Single ended against GND @ 1 kHz	10			MΩ
Input capacitance	Single ended against GND @ 1 kHz			10	pF
Effective measurement resolution			10		Bit
<b>10 bit measurement</b>					
Offset error			23	36	LSB
Gain error			32	62	LSB
INL	Code ≤ 200		+3 -14	+6 -23	LSB
	Code > 200		+3 -4	+6 -10	LSB
DNL				<±0.5	LSB
<b>8 bit measurement</b>					
Offset error			6	9	LSB
Gain error			8	16	LSB
INL	Code ≤ 50		+1 -4	+2 -6	LSB
	Code > 50		+1 -1	+2 -3	LSB
DNL				<±0.125	LSB

**Offset Error:** Describes the offset between the minimal possible code and code 0x00.

**Gain Error:** Describes the offset between maximum possible code and full scale (e.g. 0x3FF for 10 bit measurements).

**Integral Non-Linearity (INL):** Describes the difference between the ideal characteristics and the real characteristics. Only values between minimum and maximum possible code are considered (excluding offset error and gain error).

**Differential Non-Linearity (DNL):** Measures the maximum deviation from the ideal step size of 1 LSB (least significant bit).

**Effective resolution:** Results from the signal-noise ratio of the ADC and is given in Bit. The number describes how many bits can be measured stable. The criterion selected here is that the noise of DNL is <±0.5 LSB.

**Measurement Bandwidth:** The measurement bandwidth is internally limited by filters. A quasi static signal must be applied as long as the filter needs to settle.  $SettlingTime = 1 / (MeasurementBandwidth * \ln(2^{resolution[Bit]}))$

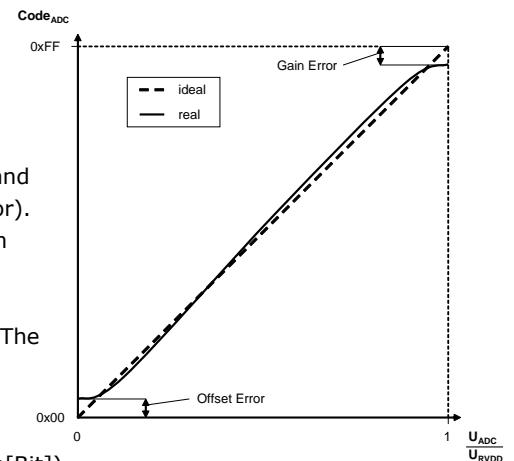

For further details please refer to the Dolphin Core Description.

<sup>1</sup> 3 dB input bandwidth, resulting in 111 μs settling time to achieve a deviation of an input signal <1 LSB (<0.098% @ 10 bit resolution).

Parameter	Conditions / Notes	Min	Typ	Max	Units
<b>Digital Input Mode</b>					
Input HIGH voltage		2/3 IOVDD			V
Input LOW voltage				1/3 IOVDD	V
Pull up resistor	@IOVDD=1.7 ... 1.9 V	90	132	200	kΩ
	@IOVDD=3.0 ... 3.6 V	38	54	85	kΩ

### 3.4 Absolute maximum ratings (non operating)

Symbol	Parameter	Min	Max	Units
VDD VDDLIM	Supply voltage at VDD and VDDLIM	-0.5	5.5	V
IOVDD	GPIO supply voltage	-0.5	3.6	V
GND	Ground connection	0	0	V
VINA	Voltage at every analog input pin	-0.5	2	V
VIND1	Voltage at RESET, WAKE0/1, and every digital input pin except WXIDIO/WXODIO	-0.5	3.6	V
VIND2	Voltage at WXIDIO / WXODIO input pin	-0.5	2	V

### 3.5 Maximum ratings (operating)

Symbol	Parameter	Min	Max	Units
VDD VDDLIM	Supply voltage at VDD and VDDLIM	VOFF	4.5	V
IOVDD	GPIO supply voltage (see also 3.3.1)	1.7	3.6	V
GND	Ground connection	0	0	V
VINA	Voltage at every analog input pin	0	2.0	V
VIND1	Voltage at RESET, WAKE0/1, and every digital input pin except WXIDIO / WXODIO	0	3.6	V
VIND2	Voltage at WXIDIO / WXODIO input pin	0	2.0	V

### 3.6 Power management and voltage regulators

Symbol	Parameter	Conditions / Notes	Min	Typ	Max	Units
<b>Voltage Regulators</b>						
VDDR	Ripple on VDD, where Min(VDD) > VON				50	mV <sub>pp</sub>
UVDD	Ultra Low Power supply			1.8		V
RVDD	RF supply		1.7	1.8	1.9	V
DVDD	Digital supply		1.7	1.8	1.9	V
<b>Voltage Limiter</b>						
VLIM	Limitation voltage			4.5		V
ILIM	Shunting current				50	mA

Threshold Detector						
VON	Turn on threshold		2.3	2.45	2.6	V
VOFF	Turn off threshold	Automatic shutdown if VDD drops below VOFF	1.85	1.9	2.1	V

**Voltage Limiter**

STM 300 provides a voltage limiter which limits the supply voltage VDD of STM 300 to a value VDDLIM which is slightly below the maximum VDD ratings by shunting of sufficient current.

**Threshold detector**

STM 300 provides an ultra low power ON/OFF threshold detector. If  $VDD > VON$ , it turns on the ultra low power regulator (UVDD), the watchdog timer and the WAKE# pins circuitry. If  $VDD \leq VOFF$  it initiates the automatic shut down of STM 300.

**3.7 Charge control output (CCO)**

After start-up STM 300 provides the output signal of the threshold detector at CCO. CCO is supplied by UVDD. The output value remains stable also when STM 300 is in deep sleep mode.

**Behaviour of CCO**

- At power up: TRISTATE until  $VDD > VON$  then HIGH
- if  $VDD > VON$  then HIGH
- if  $VDD < VON$  then LOW
- if  $VDD < VOFF$  then LOW or TRISTATE

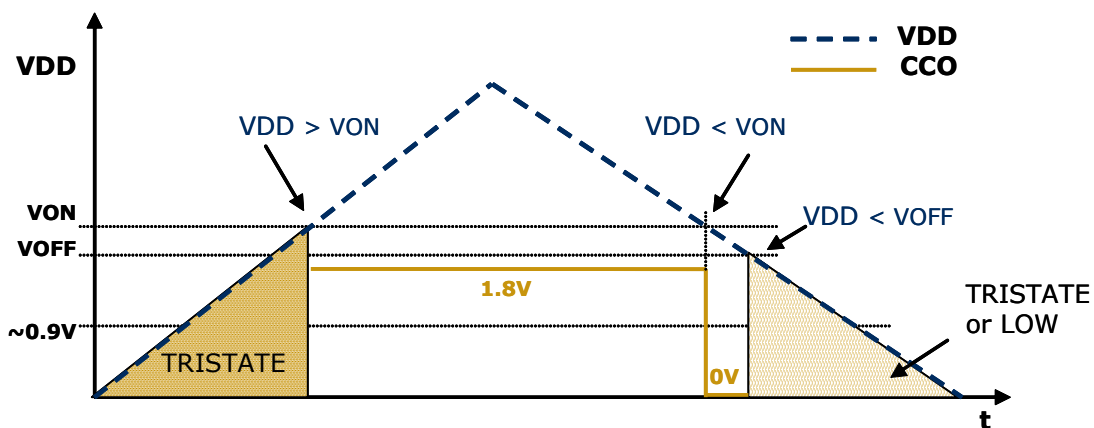

For definition of VON and VOFF please refer to 3.6.

## 3.8 Configuration

### 3.8.1 Configuration via pins

The encoding input pins have to be left open or connected to GND in correspondence with the following connection schemes. These settings are checked at every wake-up.

#### Wake-up cycle time

CW_0	CW_1	Wake-up cycle time
NC	NC	1 s $\pm$ 20%
GND	NC	10 s $\pm$ 20%
NC	GND	100 s $\pm$ 20%
GND	GND	No cyclic wake-up

#### Redundant retransmission

Via CP\_0 and CP\_1 an internal counter is set which is decreased at every wake-up signal. Once the counter reaches zero the redundant retransmission signal is sent.

CP_0	CP_1	Number of wake-ups that trigger a redundant retransmission
NC	NC	Every timer wake-up signal
GND	NC	Every 7 <sup>th</sup> - 14 <sup>th</sup> timer wake-up signal, affected at random
NC	GND	Every 70 <sup>th</sup> - 140 <sup>th</sup> timer wake-up signal, affected at random
GND	GND	No redundant retransmission



A radio telegram is always transmitted after wake-up via WAKE pins! After transmission the counter is reset to a random value within the specified interval.



According to FCC 15.231a) a redundant retransmission at every timer wake-up to determine the system integrity is only allowed in safety and security applications! In this case the total transmission time must not exceed two seconds per hour, which means that a combination with a 1 s wake-up cycle time is not allowed!

If applied in other (non-safety, non-security) applications a minimum of 10 s between periodic transmissions is required. In addition the device has to comply with the lower field strength limits of 15.231e). The limited modular approval of STM 300C is not valid in this case.



### 3.8.2 Configuration via programming interface

Via the programming interface the configuration area can be modified. This provides a lot more configuration options. Values set via programming interface override hardware settings! These settings are read after RESET or power-on reset only and not at every wake-up of the module!

Parameter	Configuration via pins	Configuration via programming interface
Wake up cycle	See section 3.8.1	Value can be set from 1 s to 65534 s
Redundant Retransmission cycle	See section 3.8.1	Min...Max values for random interval If Min=Max -> random switched off
Threshold values for analog inputs	No	The default values are: 5 LSB at AD_1 input, 6 LSB at AD_0 and 14 LSB at AD_2. The threshold value can be set between 0 and full scale for every input individually.
Resolution of the analog inputs	No	Default: AD_0: 8 bit, AD_1: 8 bit, AD_2: 8 bit Option: AD_0: 10 bit, AD_1: 6 bit, AD_2: 8 bit
Input mask	No	A digital input mask for ignoring changes on digital input pins. At default all input bits are checked.
Delay time between SCO on and sampling moment	No	Value can be set from 0 ms to 508 ms in steps of 2 ms. Default delay time is 2 ms.
Source of AD_2	No	Select if AD_2 contains measurement value of external ADIO2 pin or from internal VDD/4
Polarity of SCO signal	No	Polarity can be inversed.
Edge of wake pin change causing a telegram transmission	No	Every change of a wake pin triggers a wake-up. For both wake pins it can be configured individually if a telegram shall be sent on rising, falling or both edges.
Manufacturer ID and EEP (EnOcean Equipment Profile)	No	Information about manufacturer and type of device. This feature is needed for "automatic" interoperability of sensors and actuators or bus systems. Information how to set these parameters requires an agreement with EnOcean. Unique manufacturer IDs are distributed by the EnOcean Alliance.

The interface is shown in the figure below:

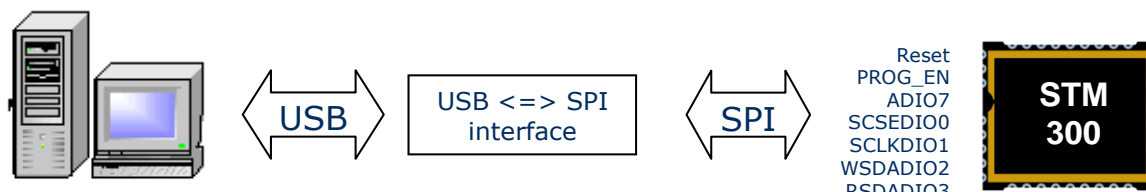

EnOcean provides EOPX (EnOcean Programmer, a command line program) and Dolphin Studio (Windows application for chip configuration, programming, and testing) and the USB/SPI programmer device as part of the EDK 350 developer's kit.

### 3.9 Radio telegram

#### 3.9.1 Normal operation

Telegram content seen at programming interface of STM 300x or at DOLPHIN API:

**ORG** = 0x07 (Telegram type "4BS")

**Data\_Byte1..3**  
3x8bit mode:

DATA\_BYTE3 = Value of AD\_2 analog input  
 DATA\_BYTE2 = Value of AD\_1 analog input  
 DATA\_BYTE1 = Value of AD\_0 analog input

1x8bit, 1x6bit, 1x10bit mode:

DATA\_BYTE3 = Value of AD\_2  
 DATA\_BYTE2 = Upper 2 bits of AD\_0 and value of AD\_1  
 DATA\_BYTE1 = Lower 8 bits Value of AD\_0 analog input

DATA_BYTE3								DATA_BYTE2				DATA_BYTE1											
AD_2								AD_1				AD_0											
7	6	5	4	3	2	1	0	5	4	3	2	1	0	9	8	7	6	5	4	3	2	1	0

**DATA\_BYTE0** = Digital sensor inputs as follows:

Bit 7	Bit 6	Bit 0
Reserved, set to 0	DI_3	DI_2
	DI_1	DI_0

ID\_BYTE3 = module identifier (Byte3)  
 ID\_BYTE2 = module identifier (Byte2)  
 ID\_BYTE1 = module identifier (Byte1)  
 ID\_BYTE0 = module identifier (Byte0)

The voltages measured at the analog inputs can be calculated from these values as follows:

$$U = (\text{Value of AD}_x) / (2^n) \times 1.8 \text{ V} \quad n = \text{resolution of channel in bit}$$

### 3.9.2 Teach-in telegram

In case a manufacturer code is programmed into the module the module transmits – instead of transmitting a normal telegram – a dedicated teach-in telegram if

- digital input DI\_3=0 at wake-up or
- wake-up via WAKE1 pin (LRN input)

With this special teach-in telegram it is possible to identify the manufacturer of a device and the function and type of a device. There is a list available from the EnOcean Alliance describing the functionalities of the respective products.



If no manufacturer code is programmed the module does not react to signal changes on WAKE1 (LRN input)!

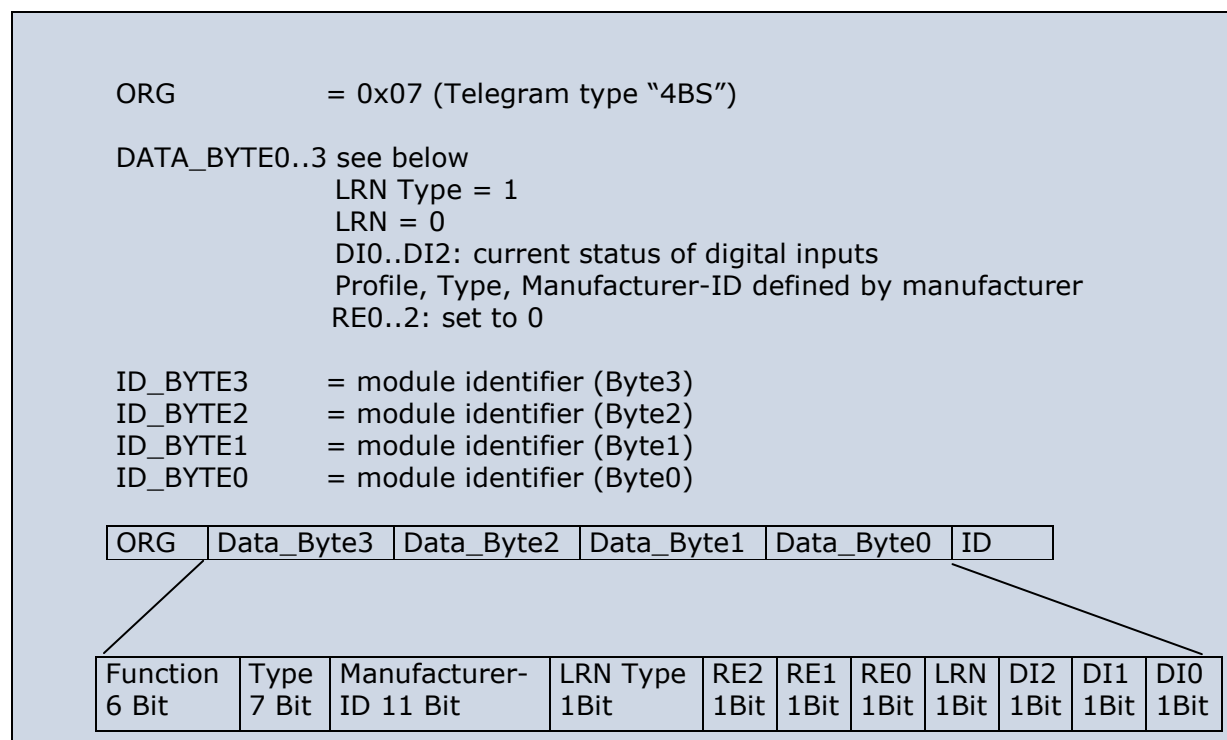

### 3.10 Transmit timing

The setup of the transmission timing allows avoiding possible collisions with data packages of other EnOcean transmitters as well as disturbances from the environment. With each transmission cycle, 3 identical subtelegrams are transmitted within 40 ms. Transmission of a subtelegram lasts approximately 1.2 ms. The delay time between the three transmission bursts is affected at random.



If a new wake-up occurs before all sub-telegrams have been sent, the series of transmissions is stopped and a new series of telegrams with new valid measurement values is transmitted.

### 3.11 Energy consumption

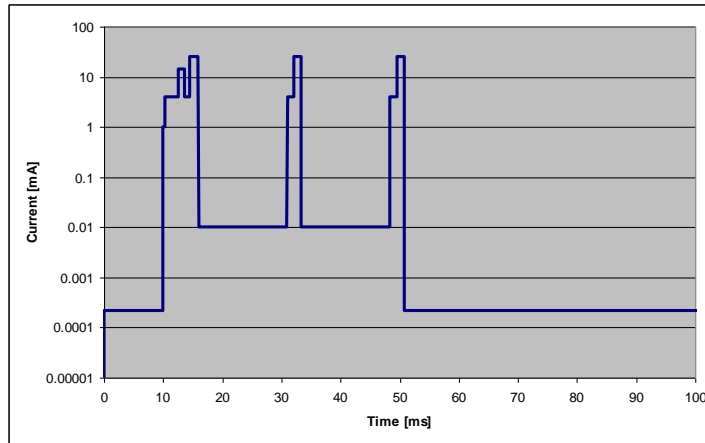

Current Consumption of STM 300

Charge needed for one measurement and transmit cycle: ~130  $\mu\text{C}$   
 Charge needed for one measurement cycle without transmit: ~30  $\mu\text{C}$   
 (current for external sensor circuits not included)

Calculations are performed on the basis of electric charges because of the internal linear voltage regulator of the module. Energy consumption varies with voltage of the energy storage while consumption of electric charge is constant.

From these values the following performance parameters have been calculated:

Wake cycle [s]	Transmit interval	Operation Time in darkness [h] when storage fully charged	Required reload time [h] at 200 lux within 24 h for continuous operation	24 h operation after 6 h illumination at x lux	Illumination level in lux for continuous operation	Current in $\mu\text{A}$ required for continuous operation
1	1	0.5	storage too small	storage too small	5220	130.5
1	10	1.7	storage too small	storage too small	1620	40.5
1	100	2.1	storage too small	storage too small	1250	31.3
10	1	5.1	storage too small	storage too small	540	13.5
10	10	16	21	storage too small	175	4.4
10	100	20	16.8	storage too small	140	3.5
100	1	43	7.8	260	65	1.6
100	10	98	3.6	120	30	0.8
100	100	112	3	100	25	0.6

Assumptions:

- Storage PAS614L-VL3 with 0.25 F,  $U_{\text{max}}=3.2\text{ V}$ ,  $U_{\text{min}}=2.2\text{ V}$ ,  $T=25^\circ\text{C}$
- Consumption: Transmit cycle 100  $\mu\text{C}$ , measurement cycle 30  $\mu\text{C}$
- Indoor solar cell, operating values 3 V and 5  $\mu\text{A}$  @ 200 lux fluorescent light (e.g. ECS 300 solar cell)
- Current proportional to illumination level (not true at very low levels!)

These values are calculated values, the accuracy is about +/-20%!

## 4 APPLICATIONS INFORMATION

### 4.1 How to connect an energy harvester and energy storage

STM 300 is designed for use with an external energy harvester and energy storage. In order to support a fast start-up and long term operation with no energy supply available usually two different storages are used. The small storage fills quickly and allows a fast start-up. The large storage fills slowly but once it is filled up it provides a large buffer for times where no energy is available, e.g. at night in a solar powered sensor. STM 300 provides a digital output CCO (see also 3.7) which allows controlling the charging of these two storages. At the beginning, as long as the voltage is below the VON voltage only the small storage is filled. Once the threshold is reached the CCO signal changes and the large storage is filled. The short term storage capacitor (C1) is usually in the range of 470 to 1000  $\mu\text{F}$ . For the long term storage we suggest a capacitor (C2) with a capacity of 0.25 F. Below an overview and the schematics of a charging circuitry is shown:

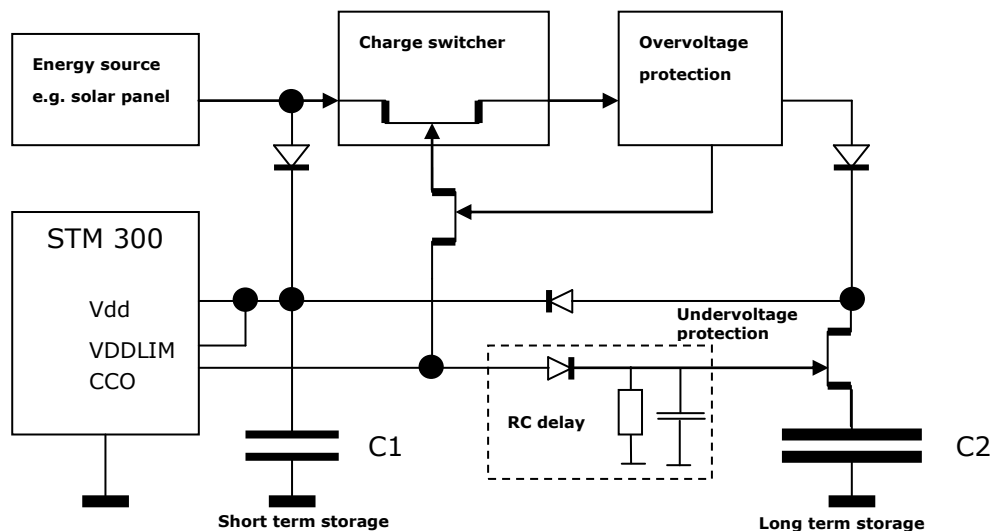

This circuit is designed for an energy storage capacitor specified for 3.3 V (e.g. PAS614L-VL3). Please pay great attention to manufacturers handling and soldering procedures!

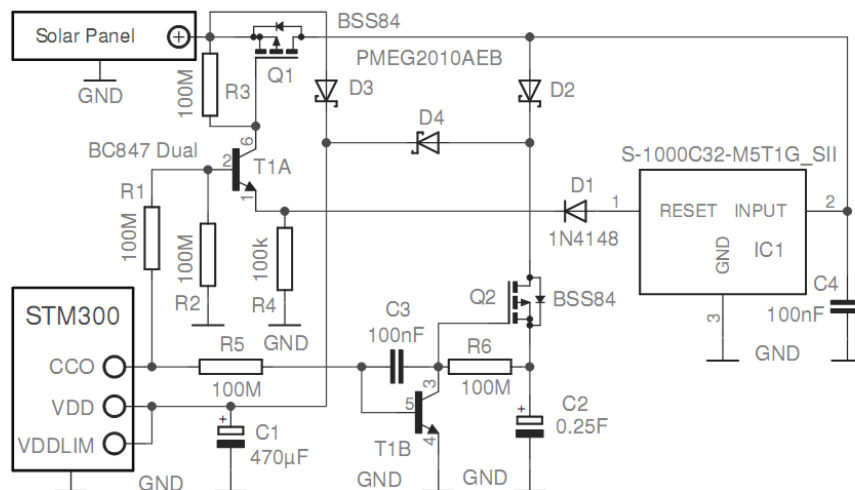

## Charge switcher

The charge switcher connects both short term storage and long term storage parallel to the energy source as soon as the STM 300 supply voltage reaches the typical  $V_{ON}$  threshold of 2.45 V. Supposing VDD then falls below  $V_{ON}$ , the energy source will be switched back to short term storage alone, for faster recharging. As long as the voltage on long term storage remains below  $V_{ON}$ , the charge switcher will continuously switch the energy source between short term and long term storage, trying to ensure continuous device operation. That is because of the higher resistance and capacitance of long term storage, which would lead to much too long charging (i.e. non-operative time). In addition short term storage cannot be charged over this threshold until the voltage on long term storage exceeds  $V_{ON}$ . Charge switcher is the PMOS transistor Q1, driven from the STM 300 charge control output CCO over T1A. To start with, as long as the STM 300 VDD voltage is below the  $V_{ON}$  threshold, only the small storage (C1) is filled over D3. Once the threshold is reached, the CCO control signal goes High, T1B and Q2 are turned on and the long term storage (C2) will be filled over Q2.

## Overvoltage protection

All of these long term storage solutions have a rated operating voltage that must be not exceeded. After reaching this limit the energy source is automatically separated from storage to avoid any damage. Overvoltage protection is implemented by the S-1000C32-M5T1x voltage detector from Seiko (SII) or the NCP300LSN30T1G series (ON Semiconductor), which limits the maximum charging voltage to 3.3 V to avoid damaging long term energy storage. In case a different voltage limit is required, this device has to be replaced by a suitable voltage variant. As soon as the voltage on D2 anode or the voltage detector input exceeds the selected threshold, the voltage detector delivers a High level on its output connected to the T1A emitter. The T1A base is consequently lower polarized than its emitter and the transistor is turned off. That means Q1 is turned off too — the energy source is switched off and long term storage is protected.

The selected voltage detector must have a very low quiescent current in the operating range, and an appropriate threshold voltage, corresponding to the selected long term energy storage voltage (e.g. threshold nominally 3.2 V for a 3.3 V capacitor). If the selected threshold is too low, e.g. 3.0 V, a relatively high amount of energy corresponding to a useful voltage difference of 0.3 V would be wasted. If the nominal threshold is too high, e.g. exactly 3.3 V (not forgetting that this could reach 3.4 V as a result of additional manufacturer tolerances), it could be critical for energy storage life expectation. The S-1000C32-M5T1x voltage detector consequently looks like the best compromise here (rated 3.2 V)

## Undervoltage protection

PAS capacitors should not be deep discharged to voltages below 1.5 V. To avoid long term degradation of their capacity and lifetime, an undervoltage protection block is added. Undervoltage protection is also implemented through Q2. In normal operation, when VDD reaches the  $V_{ON}$  threshold, the STM 300 charge control CCO goes high, T1B rapidly discharges C3 to GND and Q2 turns on long term storage. The C3 charge recovers very slowly over R6, so Q2 cannot turn off long term storage immediately. Only if VDD falls below  $V_{OFF}$  for a longer time does C3 have time to recover and finally to turn off Q2 and thus the long term storage path (over D4) from the STM 300, avoiding deep discharge.

For more details and alternative circuits please refer to application note [AN208](#).

## 4.2 Using the SCO pin

STM 300 provides an output signal at SCO which is suited to control the supply of the sensor circuitry. This helps saving energy as the sensor circuitry is only powered as long as necessary. In the default configuration SCO provides a HIGH signal 2 ms (delay time) before the analog inputs are read. Via the programming interface (see 3.8.2) it is possible to adjust the delay time and also the polarity of the signal.

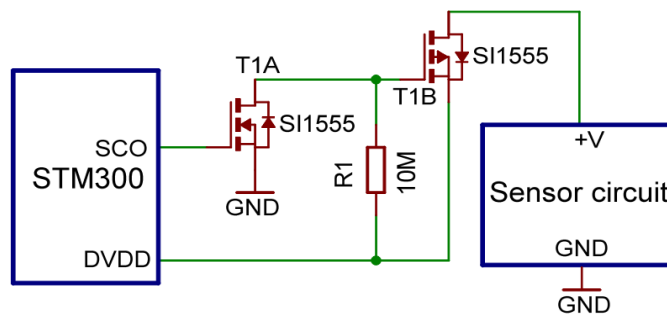

The figure above shows, how the SCO pin (with default polarity) can be used to control an external sensor circuit.



Do not supply sensors directly from SCO as this output can only provide maximum 15  $\mu$ A!

## 4.3 Using the WAKE pins

The logic input circuits of the WAKE0 and WAKE1 pins are supplied by UVDD and therefore also usable in "Deep Sleep Mode" or "Flywheel Sleep Mode" (via API only). Due to current minimization there is no internal pull-up or pull-down at the WAKE pins.

When STM 300 is in "Deep Sleep Mode" or "Flywheel Sleep Mode" (via API only) and the logic levels of WAKE0 and / or WAKE1 is changed, STM 300 starts up.



As there is no internal pull-up or pull-down at the WAKE pins, it has to be ensured by external circuitry, that the WAKE pins are at a defined logic level at any time.



When using the UVDD regulator output as source for the logic HIGH of the WAKE pins, it is strongly recommended to protect the ultra low power UVDD voltage regulator against (accidental) excessive loading by connection of an external 1.8 M $\Omega$  series resistor.

STM 300 / STM 300C / STM 300U

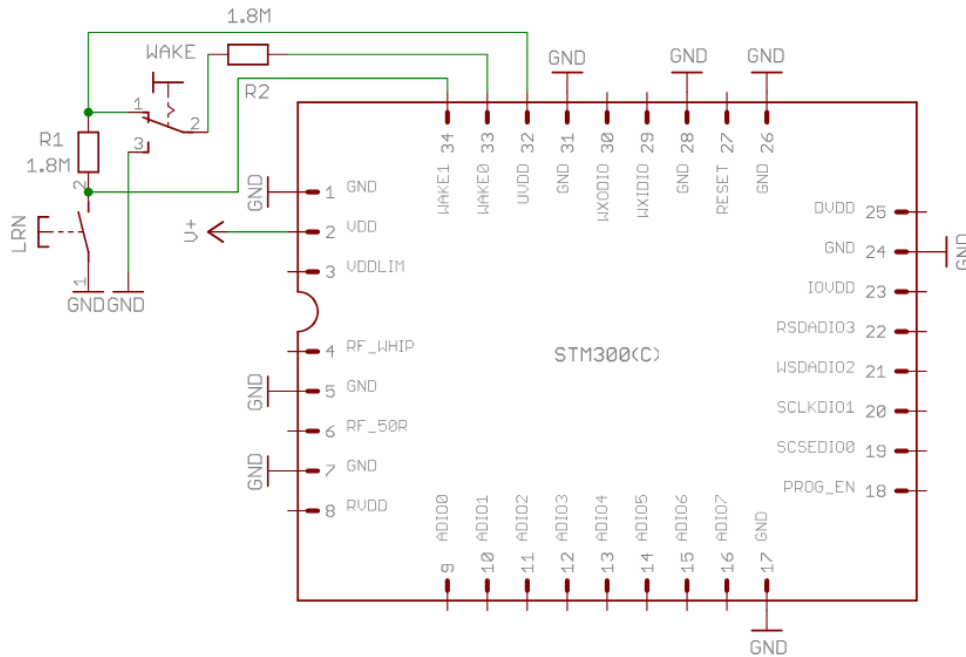

The figure above shows two examples how the WAKE inputs may be used. When the LRN button is pressed WAKE1 is pulled to GND and a teach-in telegram is transmitted. As long as the button is pressed a small current is flowing from UVDD to GND. WAKE0 is connected to a toggle switch. There is no continuous flow of current in either position of the switch.

If more digital inputs with WAKE functionality are needed in an application, WAKE0 can be combined with some of the digital inputs as shown below:

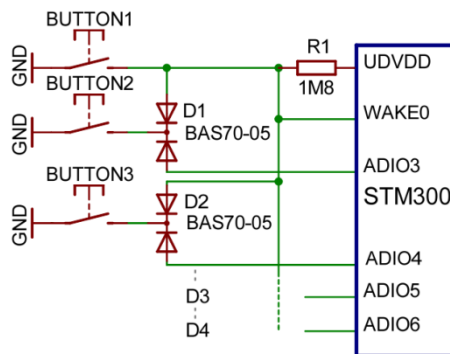

**4.4 Using RVDD**

If RVDD is used in an application circuit a serial ferrite bead shall be used and wire length should be as short as possible (<3 cm). The following ferrite beads have been tested: 74279266 (0603), 74279205 (0805) from Würth Elektronik. During radio transmission and reception only small currents may be drawn ( $I < 100 \mu A$ ).

Pulsed current drawn from RVDD has to be avoided. If pulsed currents are necessary, sufficient blocking has to be provided.



## 4.5 Antenna options STM 300x

### 4.5.1 Overview

Several antenna types have been investigated by EnOcean. Please refer to our application notes AN102, and AN105 which give an overview on our recommendations.

All STM300x modules have been approved with whip antenna, and STM 300U with helical and chip antenna in addition.

868.300 MHz modules used in Europe do not need additional approval if the external antenna fulfils the following requirements:

Frequency band	868.300 MHz ISM	Antenna must be suited for this band
Antenna type	Passive	Mandatory for radio approval
Impedance	~50 Ohm	Mandatory for radio approval
Maximum gain	≤ 0 dBd	Mandatory for radio approval

In addition it is important to fulfill the following requirements in order to achieve compatibility with other EnOcean products and to ensure excellent EMI robustness:

VSWR	≤ 3:1	Important for compatibility with EnOcean protocol
Return Loss	> 6 dB	Important for compatibility with EnOcean protocol
Bandwidth	≤ 20 MHz	Important if 10 V/m EMI robustness required for device



**For 315 MHz / 902.875 MHz modules (STM 300C / STM 300U) please note that a full approval is needed if modules are used with antennas other than the specified antennas.**

### 4.5.2 Whip antenna

#### 315 MHz

Antenna: 150 mm wire, connect to RF\_WHIP  
 Minimum GND plane: 50 mm x 50 mm  
 Minimum distance space: 10 mm

#### 868.3 MHz

Antenna: 86 mm wire, connect to RF\_WHIP  
 Minimum GND plane: 38 mm x 18 mm  
 Minimum distance space: 10 mm

#### 902.875 MHz

Antenna: 64 mm wire, connect to RF\_WHIP  
 Minimum GND plane: 50 mm x 50 mm  
 Minimum distance space: 10 mm

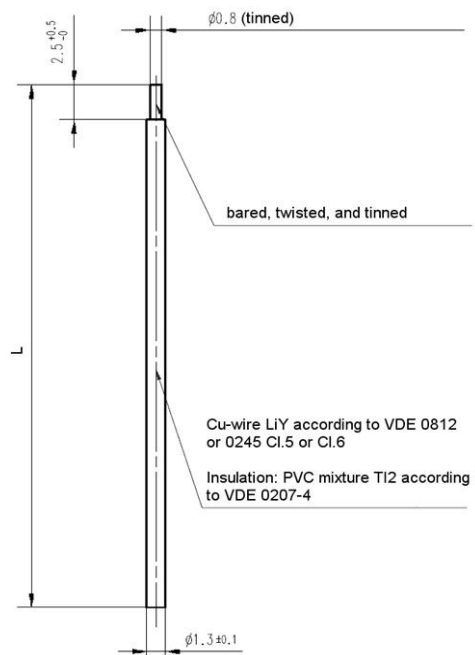

**4.5.3 Helical antenna (supplier: EnOcean)**

**315 MHz**

EnOcean Type: ANT 300C

Dimensions differ from drawing below. No limited modular approval available. Please contact EnOcean for MOQ.

**868.3 MHz**

EnOcean Type: ANT 300

Dimensions according to drawing below

Connect to RF\_WHIP

Please contact EnOcean for MOQ.

Minimum GND plane: 35 mm x 30 mm

Minimum distance space: 10 mm

**902.875 MHz**

Limited modular approval available

Please contact EnOcean for MOQ and necessary limited modular approval user agreement.

Dimensions according to drawing below.

Connect to RF\_WHIP.

Minimum GND plane: 35 mm x 30 mm

Minimum distance space: 10 mm

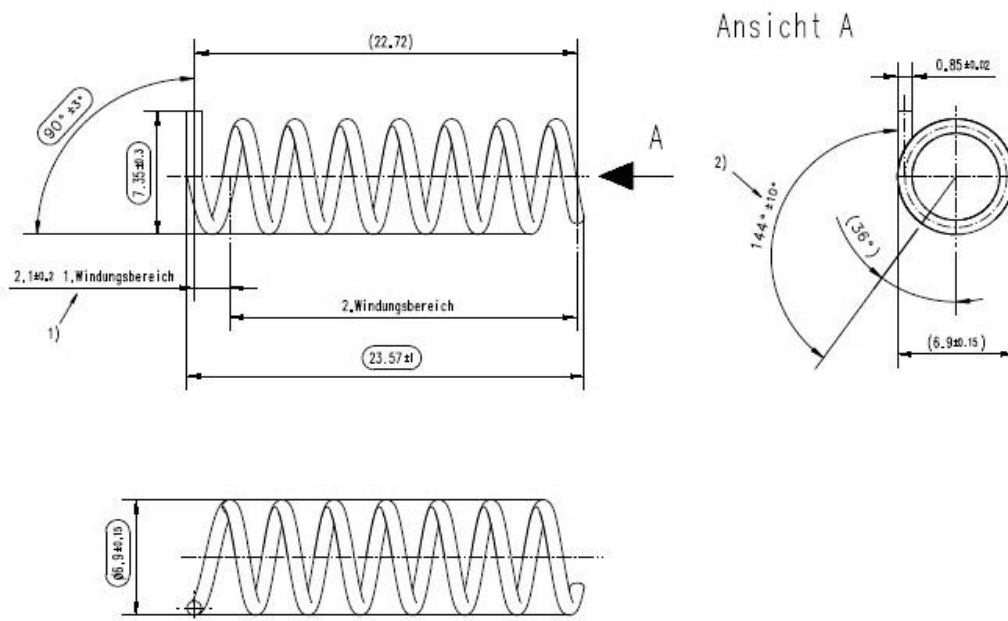

#### 4.5.4 Chip antenna (supplier: Mitsubishi Material, Type AM11DG-ST01)

##### 315 MHz

Modular approval not available. Range and gain significantly reduced because of antenna size vs. the wavelength. Small chip antennas at this frequency may be suited for space-constrained applications. Check with supplier for matching circuit and board design guidelines. Supplier can make recommendations or do testing to optimize individual PCB design.

##### 868.3 MHz

Additional matching circuit and proper board design is required. Check with supplier for matching circuit and board design guidelines. Connect matching circuit to RF\_50 using 50 Ohm strip lines. Please follow 902 MHz board design recommendations and dimensions. Be aware that matching values differ!

##### 902.875 MHz

Limited modular approval is available. Please contact EnOcean to sign the mandatory limited modular approval user agreement. Dimensions may not be shortened. Matching circuit is part of the limited modular approval and may not be changed. Minimum top and bottom side ground plane required as shown below. Connect ground planes using multiple via as shown. Connect matching circuit to RF\_50. Use High Q wire wound inductors, e.g. 0603 Murata LQW18A series. Matching circuits values: L1 = 3.9nH; L2 = 33nH, L3 = 12nH. This antenna evaluation board is available upon request for use with EnOcean EDK 350 developer kit.

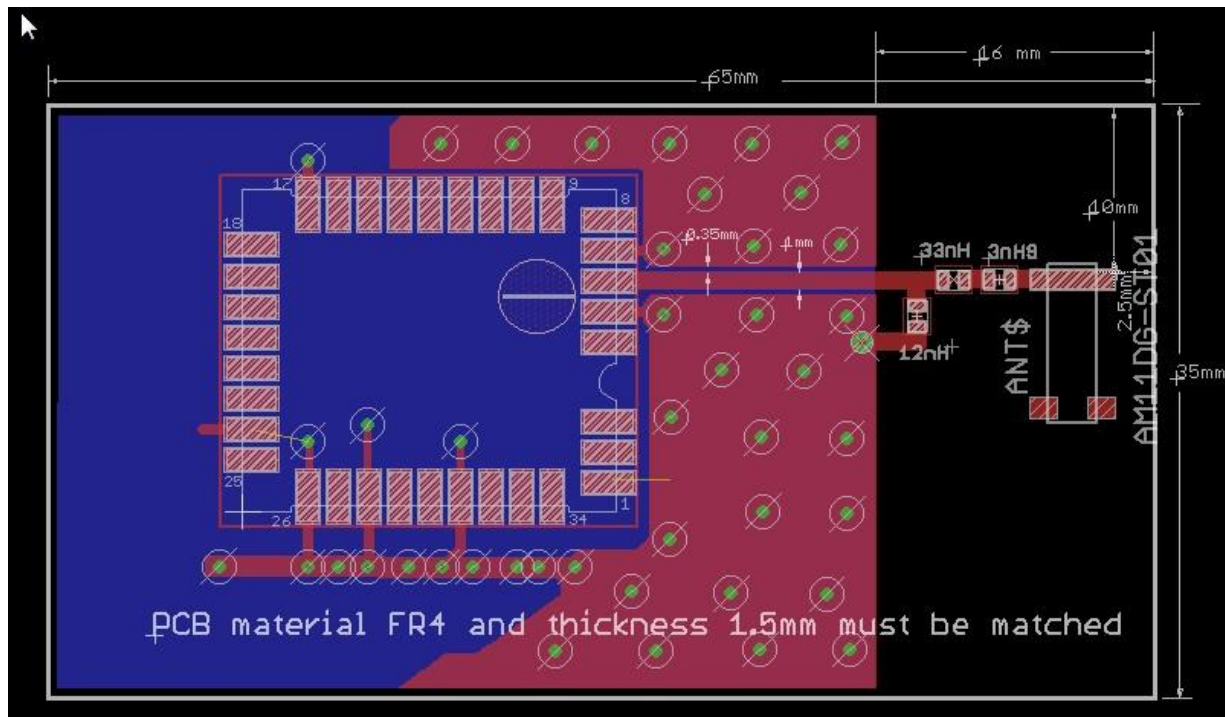

For any further questions or chip antenna quotes, please refer to Mitsubishi Materials website at [www.mmea.com](http://www.mmea.com) or email to [electroniccomponents@mmus.com](mailto:electroniccomponents@mmus.com).

## 4.6 Positioning of the whip antenna

Positioning and choice of receiver and transmitter antennas are the most important factors in determining system transmission range.

For good receiver performance, great care must be taken about the space immediately around the antenna since this has a strong influence on screening and detuning the antenna. The antenna should be drawn out as far as possible and must never be cut off. Mainly the far end of the wire should be mounted as far away as possible (at least 15 mm) from all metal parts, ground planes, PCB strip lines and fast logic components (e.g. microprocessors).

Do not roll up or twist the whip antenna!

Radio frequency hash from the motherboard desensitizes the receiver. Therefore:

- PCB strip lines on the user board should be designed as short as possible
- A PCB ground plane layer with sufficient ground via is strongly recommended
- Keep antenna away from noise generating parts of the circuit. Problems may especially occur with switching power supplies!

### 4.7 Recommendations for laying a whip antenna

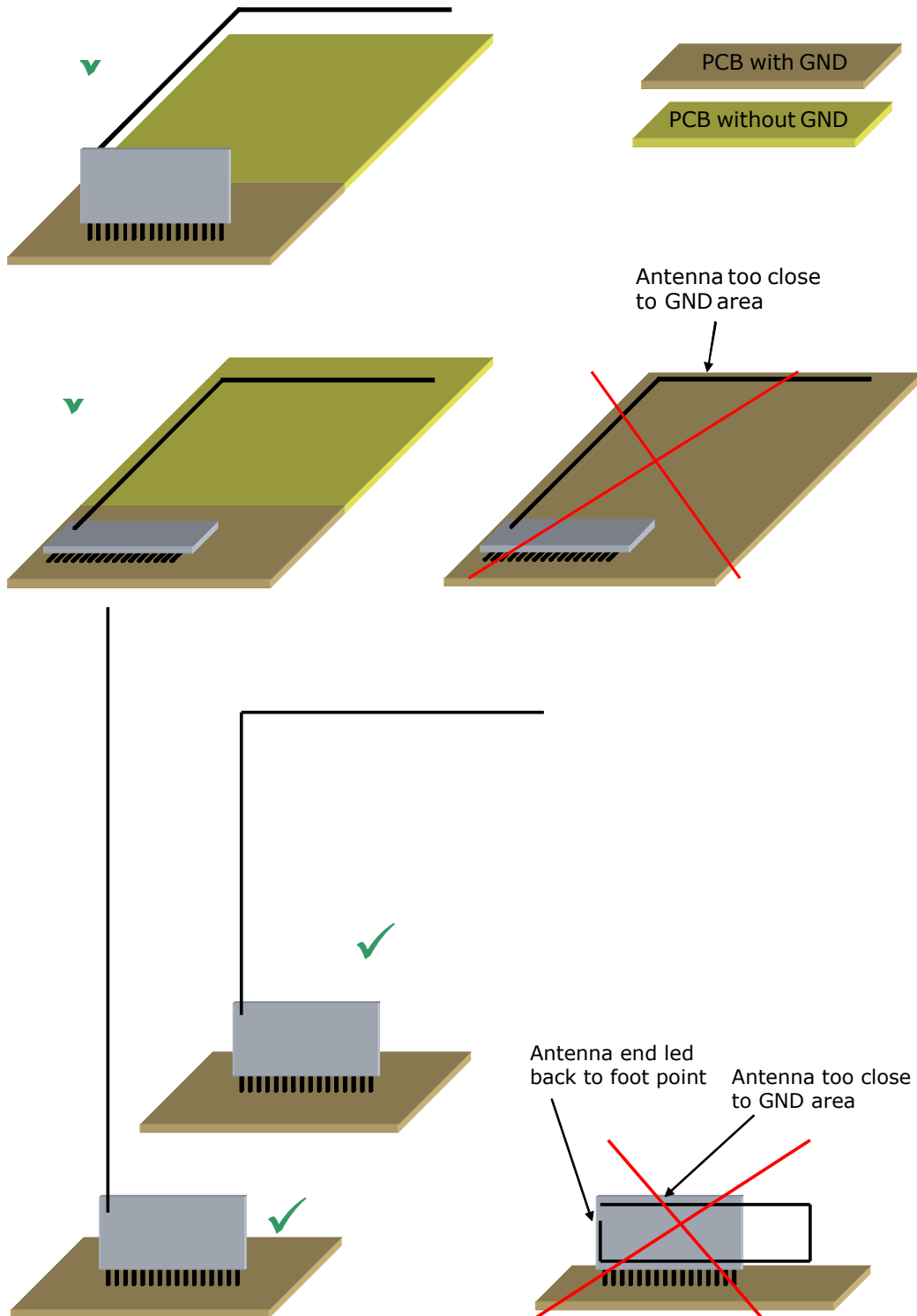

## 4.8 Layout recommendations for foot pattern



The length of lines connected to I/Os should not exceed 5 cm.



It is recommended to have a complete GND layer in the application PCB, at least in the area below the module and directly connected components (e.g. mid-layer of your application PCB).

Due to unisolated test points there are live signals accessible on the bottom side of the module.

Please regard the following advices to prevent interference with your application circuit:

- Avoid any copper structure in the area directly underneath the module (top-layer layout of your application PCB). If this is not possible in your design, please provide coating on top of your PCB to prevent short circuits to the module test pads. All bare metal surfaces including via have to be covered (e.g. adequate layout of solder resist).
- It is mandatory that the area marked by the circle in the figure below is kept clear of any conductive structures in the top layer and 0.3 mm below. Otherwise RF performance will be degraded!

Furthermore, any distortive signals (e.g. bus signals or power lines) should not be routed underneath the module. If such signals are present in your design, we suggest separating them by using a ground plane between module and these signal lines.



The RVDD line should be kept as short as possible. Please consider recommendations in section 4.4.

Top layer

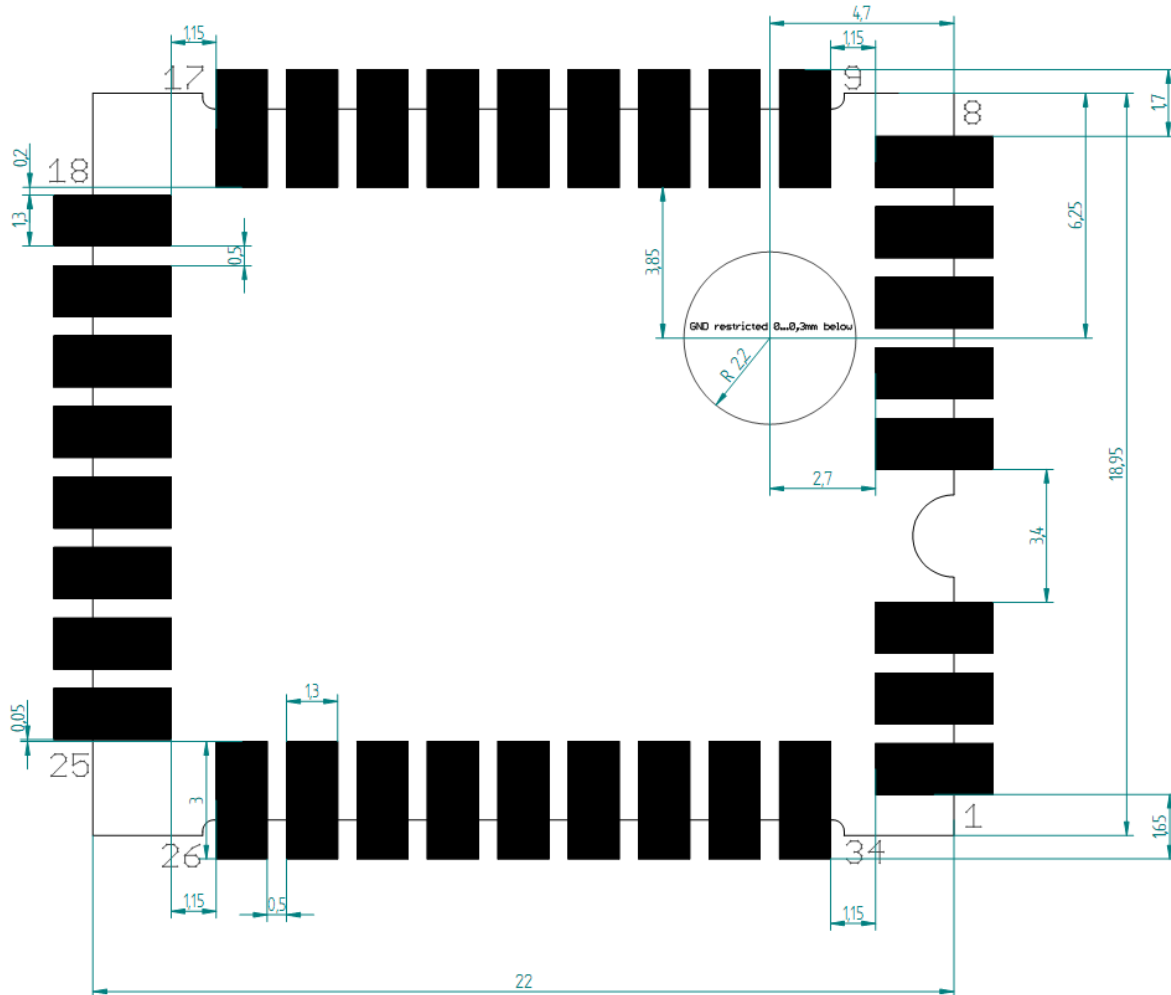

**Solder resist top layer**

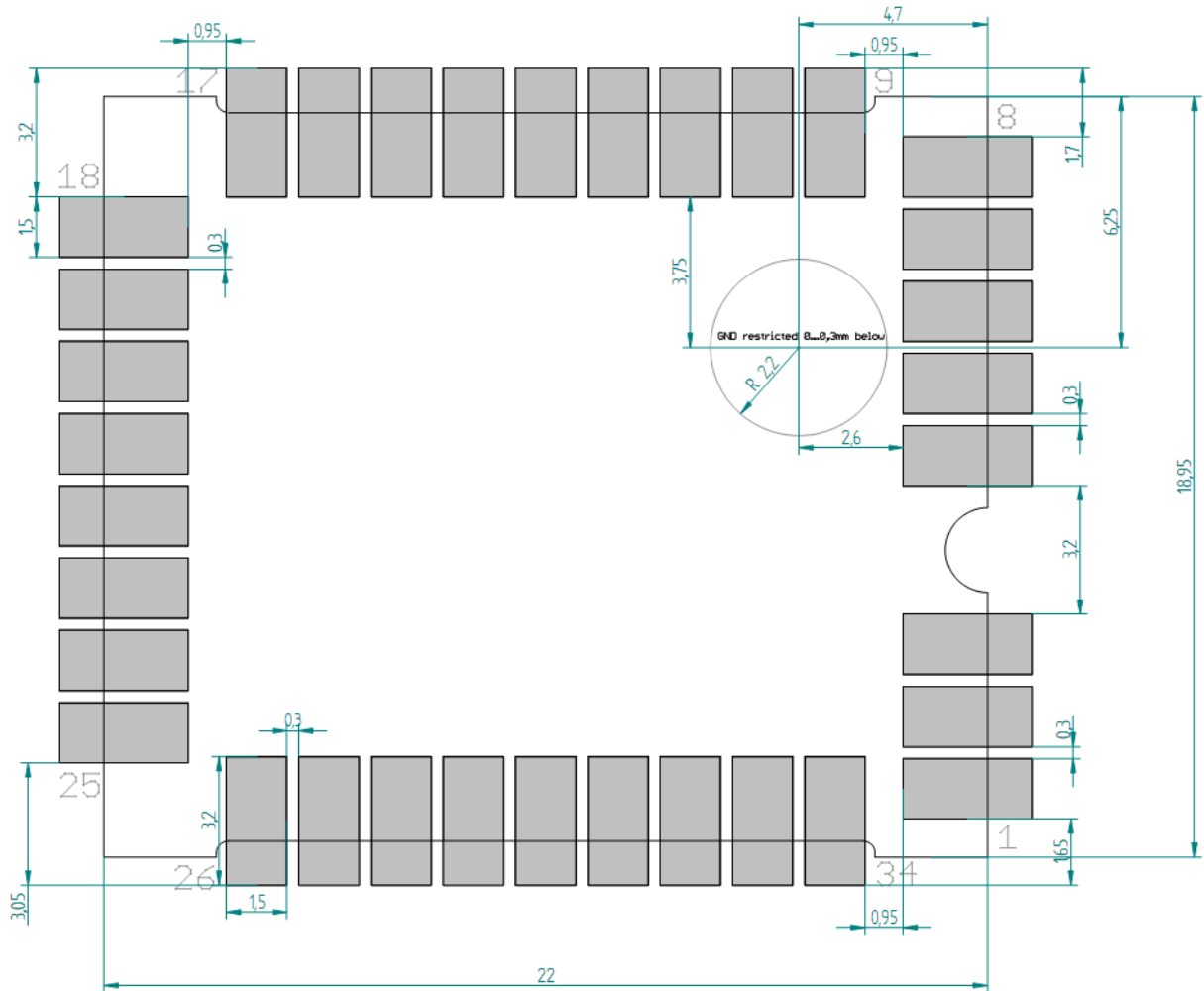



**Solder paste top layer**

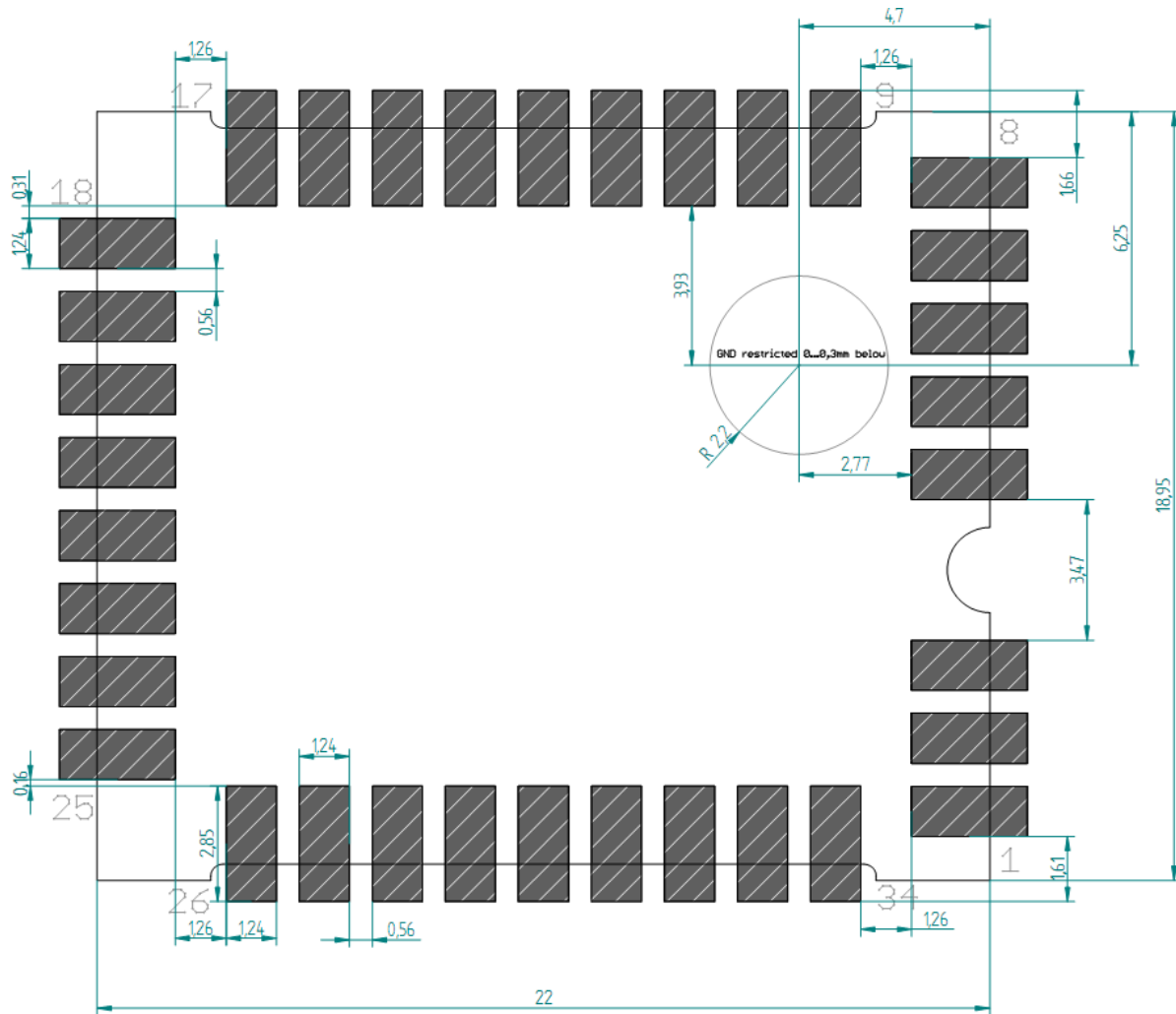

The data above is also available as EAGLE library.

In order to ensure good solder quality a solder mask thickness of 150 µm is recommended.

In case a 120 µm solder mask is used, it is recommended to enlarge the solder print. The pads on the solder print should then be 0.1 mm larger than the pad dimensions of the module as specified in chapter 2.3. (not relative to the above drawing).

Nevertheless an application and production specific test regarding the amount of soldering paste should be performed to find optimum parameters.

### 4.9 Soldering information

STM 300 has to be soldered according to IPC/JEDEC J-STD-020C standard.

Profile Feature	Pb-Free Assembly
Average Ramp-Up Rate ( $T_{S_{max}}$ to $T_p$ )	3° C/second max.
<b>Preheat</b>	
- Temperature Min ( $T_{S_{min}}$ )	150 °C
- Temperature Max ( $T_{S_{max}}$ )	200 °C
- Time ( $t_{S_{min}}$ to $t_{S_{max}}$ )	60-180 seconds
Time maintained above:	
- Temperature ( $T_L$ )	217 °C
- Time ( $t_L$ )	60-150 seconds
Peak/Classification Temperature ( $T_p$ )	260 °C
Time within 5 °C of actual Peak Temperature ( $t_p$ )	20-40 seconds
Ramp-Down Rate	6 °C/second max.
Time 25 °C to Peak Temperature	8 minutes max.

Note 1: All temperatures refer to topside of the package, measured on the package body surface.

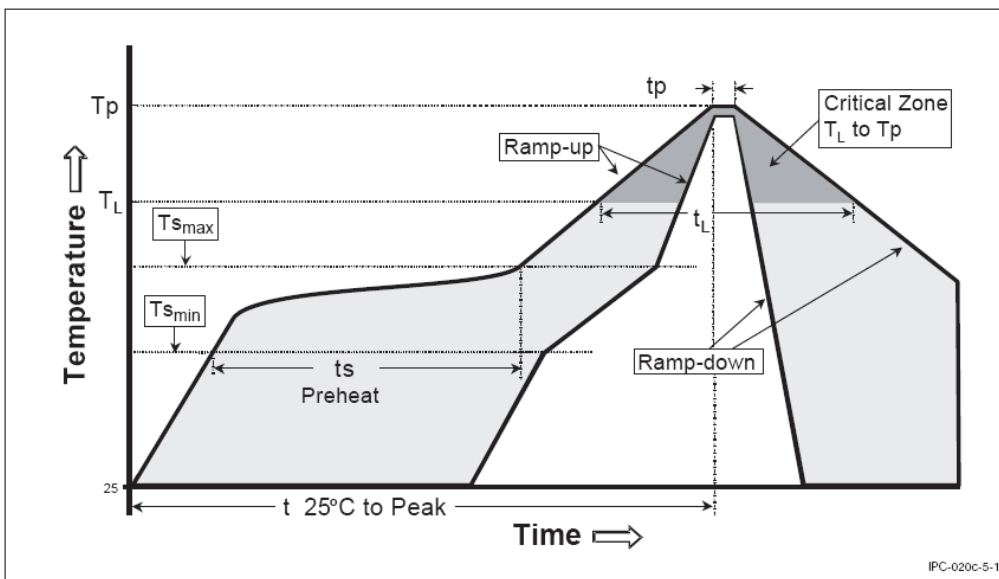

STM 300 shall be handled according to Moisture Sensitivity Level MSL4 which means a floor time of 72 h. STM 300 may be soldered only once, since one time is already consumed at production of the module itself.

Once the dry pack bag is opened, the desired quantity of units should be removed and the bag resealed within two hours. If the bag is left open longer than 30 minutes the desiccant should be replaced with dry desiccant. If devices have exceeded the specified floor life time of 72 h, they may be baked according IPC/JEDEC J-STD-033B at max. 90°C for less than 60 h.

Devices packaged in moisture-proof packaging should be stored in ambient conditions not exceeding temperatures of 40 °C or humidity levels of 90% r.h.

STM 300 modules have to be soldered within 6 months after delivery!

### 4.10 Tape & Reel specification

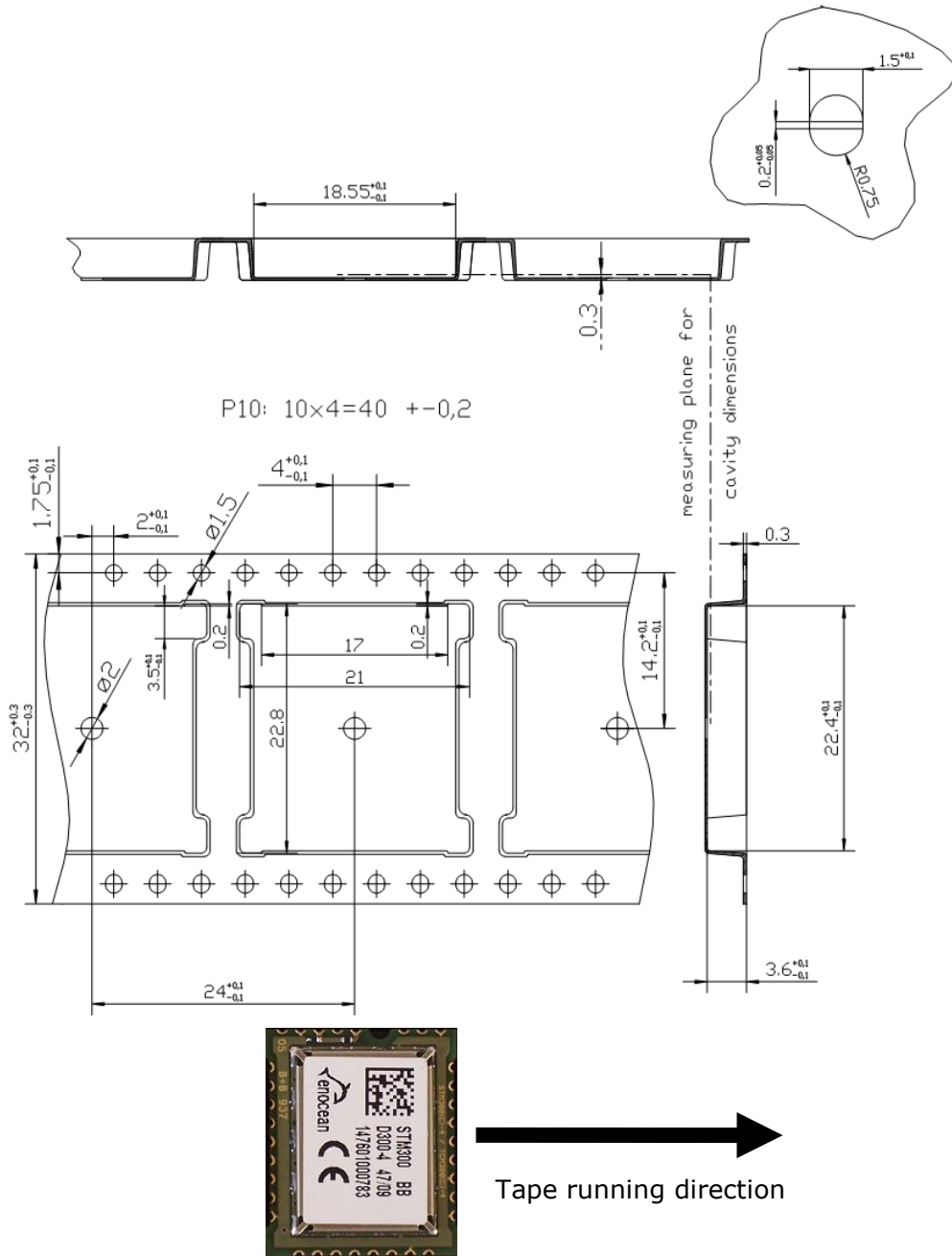

#### 4.11 Transmission range

The main factors that influence the system transmission range are type and location of the antennas of the receiver and the transmitter, type of terrain and degree of obstruction of the link path, sources of interference affecting the receiver, and “Dead” spots caused by signal reflections from nearby conductive objects. Since the expected transmission range strongly depends on this system conditions, range tests should categorically be performed before notification of a particular range that will be attainable by a certain application.

The following figures for expected transmission range are considered by using a PTM, a STM or a TCM radio transmitter device and the TCM radio receiver device with preinstalled whip antenna and may be used as a rough guide only:

- Line-of-sight connections: Typically 30 m range in corridors, up to 100 m in halls
- Plasterboard walls / dry wood: Typically 30 m range, through max. 5 walls
- Line-of-sight connections: Typically 30 m range in corridors, up to 100 m in halls
- Ferroconcrete walls / ceilings: Typically 10 m range, through max. 1 ceiling
- Fire-safety walls, elevator shafts, staircases and supply areas should be considered as screening.

The angle at which the transmitted signal hits the wall is very important. The effective wall thickness – and with it the signal attenuation – varies according to this angle. Signals should be transmitted as directly as possible through the wall. Wall niches should be avoided. Other factors restricting transmission range:

- Switch mounted on metal surfaces (up to 30% loss of transmission range)
- Hollow lightweight walls filled with insulating wool on metal foil
- False ceilings with panels of metal or carbon fiber
- Lead glass or glass with metal coating, steel furniture

The distance between EnOcean receivers and other transmitting devices such as computers, audio and video equipment that also emit high-frequency signals should be at least 0.5 m

A summarized application note to determine the transmission range within buildings is available as download from [www.enocean.com](http://www.enocean.com).

## 5 AGENCY CERTIFICATIONS

The modules have been tested to fulfil the approval requirements for CE (STM 300) and FCC/IC (STM 300C / STM 300U) based on the built-in firmware.



**When developing customer specific firmware based on the API for this module, special care must be taken not to exceed the specified regulatory limits, e.g. the duty cycle limitations!**

### 5.1 CE approval

The modules bear the EC conformity marking CE and conform to the R&TTE EU-directive on radio equipment. The assembly conforms to the European and national requirements of electromagnetic compatibility. The conformity has been proven and the according documentation has been deposited at EnOcean. The modules can be operated without notification and free of charge in the area of the European Union, and in Switzerland. The following provisos apply:

- EnOcean RF modules must not be modified or used outside their specification limits.
- EnOcean RF modules may only be used to transfer digital or digitized data. Analog speech and/or music are not permitted.
- The final product incorporating EnOcean RF modules must itself meet the essential requirement of the R&TTE Directive and a CE marking must be affixed on the final product and on the sales packaging each. Operating instructions containing a Declaration of Conformity has to be attached.
- If the transmitter is used according to the regulations of the 868.3.3 MHz band, a so-called "Duty Cycle" of 1% per hour must not be exceeded. Permanent transmitters such as radio earphones are not allowed.
- The module must be used with only the following approved antenna(s).

Type	Parameter	Value
Wire/Monopole at RF_WHIP	Maximum gain	1.0 dBi
External antenna at RF_50	Antenna type	Passive
	Impedance	~50 Ohm
	Maximum gain	≤ 0 dBd

## 5.2 FCC (United States) Certification

### STM 300C / STM 300U LIMITED MODULAR APPROVAL

This is an RF module approved for Limited Modular use operating as an intentional transmitting device with respect to 47 CFR 15.231(a-c) and is limited to OEM installation. The module is optimized to operate using small amounts of energy, and may be powered by a battery. The module transmits short radio packets comprised of control signals, (in some cases the control signal may be accompanied with data) such as those used with alarm systems, door openers, remote switches, and the like. The module does not support continuous streaming of voice, video, or any other forms of streaming data; it sends only short packets containing control signals and possibly data. The module is designed to comply with, has been tested according to 15.231(a-c), and has been found to comply with each requirement. Thus, a finished device containing the STM 300C or the STM 300U radio module can be operated in the United States without additional Part 15 FCC approval (approval(s) for unintentional radiators may be required for the OEM's finished product), under EnOcean's FCC ID number. This greatly simplifies and shortens the design cycle and development costs for OEM integrators. The module can be triggered manually or automatically, which cases are described below.

#### Manual Activation

The radio module can be configured to transmit a short packetized control signal if triggered manually. The module can be triggered, by pressing a switch, for example. The packet contains one (or more) control signals that is(are) intended to control something at the receiving end. The packet may also contain data. Depending on how much energy is available from the energy source, subsequent manual triggers can initiate the transmission of additional control signals. This may be necessary if prior packet(s) was(were) lost to fading or interference. Subsequent triggers can also be initiated as a precaution if any doubt exists that the first packet didn't arrive at the receiver. Each packet that is transmitted, regardless of whether it was the first one or a subsequent one, will only be transmitted if enough energy is available from the energy source.

#### Automatic Activation

The radio module also can be configured to transmit a short packetized control signal if triggered automatically, by a relevant change of its inputs or in response to receiving a signal from another transmitter, for example. Again, the packet contains a control signal that is intended to control something at the receiving end and may also contain data. As above, it is possible for the packet to get lost and never reach the receiver. However, if enough energy is available from the energy source, and the module has been configured to do so, then another packet or packets containing the control signal may be transmitted at a later time.

The device is capable to operate as a repeater, which can receive signals from the following list of FCC/IC approved transmitters, and retransmit the signals.

#### STM 300C (315 MHz):

■ PTM 200C	FCC ID:SZV-PTM200C	IC:5713A-PTM200C
■ STM 110C	FCC ID:SZV-STM110C	IC:5713A-STM110C
■ TCM 200C	FCC ID:SZV-TCM2XXC	IC:5713A-TCM2XXC
■ TCM 220C	FCC ID:SZV-TCM2XXC	IC:5713A-TCM2XXC
■ TCM 300C	FCC ID:SZV-STM300C	IC:5713A-STM300C
■ TCM 310C	FCC ID:SZV-STM300C	IC:5713A-STM300C

## STM 300 / STM 300C / STM 300U

- |            |                    |                  |
|------------|--------------------|------------------|
| ■ STM 300C | FCC ID:SZV-STM300C | IC:5713A-STM300C |
| ■ TCM 320C | FCC ID:SZV-TCM320C | IC:5713A-TCM320C |

## STM 300U: (902.875 MHz)

- |            |                    |                  |
|------------|--------------------|------------------|
| ■ PTM 210U | FCC ID:SZV-PTM210U | IC:5713A-PTM210U |
| ■ STM 300U | FCC ID:SZV-STM300U | IC:5713A-STM300U |
| ■ TCM 300U | FCC ID:SZV-STM300U | IC:5713A-STM300U |
| ■ TCM 310U | FCC ID:SZV-STM300U | IC:5713A-STM300U |
| ■ TCM 320U | FCC ID:SZV-TCM320U | IC:5713A-TCM320U |

**OEM Requirements**

In order to use EnOcean's FCC ID number, the OEM must ensure that the following conditions are met:

- End users of products, which contain the module, must not have the ability to alter the firmware that governs the operation of the module. The agency grant is valid only when the module is incorporated into a final product by OEM integrators.
- The end-user must not be provided with instructions to remove, adjust or install the module.
- The Original Equipment Manufacturer (OEM) must ensure that FCC labeling requirements are met. This includes a clearly visible label on the outside of the final product. Attaching a label to a removable portion of the final product, such as a battery cover, is not permitted. The label must include the following text:

## STM 300C:

*Contains FCC ID: SZV-STM300C*

*The enclosed device complies with Part 15 of the FCC Rules. Operation is subject to the following two conditions: (i.) this device may not cause harmful interference and (ii.) this device must accept any interference received, including interference that may cause undesired operation.*

## STM 300U:

*Contains FCC ID: SZV-STM300U*

*The enclosed device complies with Part 15 of the FCC Rules. Operation is subject to the following two conditions: (i.) this device may not cause harmful interference and (ii.) this device must accept any interference received, including interference that may cause undesired operation.*

When the device is so small or for such use that it is not practicable to place the statement above on it, the information required by this paragraph shall be placed in a prominent location in the instruction manual or pamphlet supplied to the user or, alternatively, shall be placed on the container in which the device is marketed. However, the FCC identifier or the unique identifier, as appropriate, must be displayed on the device.

The user manual for the end product must also contain the text given above.

- Changes or modifications not expressly approved by EnOcean could void the user's authority to operate the equipment.
- The module must be used with only the following approved antenna(s).

Part Number	Type	Gain
N.A.	Wire/Monopole	1.0 dBi
N.A.	Helical (for STM300U only)	1.0 dBi

- The OEM must ensure that timing requirements according to 47 CFR 15.231(a-c) are met.
- The OEM must sign the OEM Limited Modular Approval Agreement with EnOcean

### 5.3 IC (Industry Canada) Certification

In order to use EnOcean's IC number, the OEM must ensure that the following conditions are met:

- Labeling requirements for Industry Canada are similar to those required by the FCC. The Original Equipment Manufacturer (OEM) must ensure that IC labeling requirements are met. A clearly visible label on the outside of a non-removable part of the final product must include the following text:

STM 300C:

*Contains IC: 5713A-STM300C*

*Contient le module d'émission IC: 5713A-STM300C*

STM 300U:

*Contains IC: 5713A-STM300U*

*Contient le module d'émission IC: 5713A-STM300U*

- The OEM must sign the OEM Limited Modular Approval Agreement with EnOcean

Pour utiliser le numéro IC EnOcean, le OEM doit s'assurer que les conditions suivantes sont remplies:

- Les exigences d'étiquetage pour Industrie Canada sont similaires à ceux exigés par la FCC. Le fabricant d'équipement d'origine (OEM) doit s'assurer que les exigences en matière d'étiquetage IC sont réunies. Une étiquette clairement visible à l'extérieur d'une partie non amovible du produit final doit contenir le texte suivant:



**STM 300C:**

*Contains IC: 5713A-STM300C*

*Contient le module d'émission IC: 5713A-STM300C*

**STM 300U:**

*Contains IC: 5713A-STM300U*

*Contient le module d'émission IC: 5713A-STM300U*

- L'OEM doit signer l'accord OEM limitée Approbation modulaire avec EnOcean

## 5.4 FCC Regulatory Statements

This device complies with part 15 of the FCC rules. Operation is subject to the following two conditions: (1) This device may not cause harmful interference, and (2) this device must accept any interference received, including interference that may cause undesired operation. Any changes or modifications not expressly approved by manufacturer could void the user's authority to operate the equipment.

**IMPORTANT!** Any changes or modifications not expressly approved by the party responsible for compliance could void the user's authority to operate this equipment.

**NOTE:** This equipment has been tested and found to comply with the limits for a Class B digital device, pursuant to part 15 of the FCC Rules. These limits are designed to provide reasonable protection against harmful interference in a residential installation. This equipment generates, uses and can radiate radio frequency energy and, if not installed and used in accordance with the instructions, may cause harmful interference to radio communications. However, there is no guarantee that interference will not occur in a particular installation. If this equipment does cause harmful interference to radio or television reception, which can be determined by turning the equipment off and on, the user is encouraged to try to correct the interference by one or more of the following measures:

- Reorient or relocate the receiving antenna.
- Increase the separation between the equipment and receiver.
- Connect the equipment into an outlet on a circuit different from that to which the receiver is connected.
- Consult the dealer or an experienced radio/ TV technician for help.

## 5.5 Industry Canada Regulatory Statements

This device complies with Industry Canada licence-exempt RSS standard(s). Operation is subject to the following two conditions: (1) this device may not cause interference, and (2) this device must accept any interference, including interference that may cause undesired operation of the device.

Le présent appareil est conforme aux CNR d'Industrie Canada applicables aux appareils radio exempts de licence. L'exploitation est autorisée aux deux conditions suivantes: (1) l'appareil ne doit pas produire de brouillage, et (2) l'utilisateur de l'appareil doit accepter tout brouillage radioélectrique subi, même si le brouillage est susceptible d'en compromettre le fonctionnement.

**IMPORTANT!** Tous les changements ou modifications pas expressément approuvés par la partie responsable de la conformité ont pu vider l'autorité de l'utilisateur pour actionner cet équipement.

This Class B digital apparatus complies with Canadian ICES-003.  
Cet appareil numérique de la classe B est conforme à la norme NMB-003 du Canada