

EDP70 PLUS

**UNINTERRUPTIBLE POWER SYSTEM
24/36/50/80kVA –
3 phase input / 3 phase output**



USER HANDBOOK
PART NUMBER 10H52152PU9C rev.1

IMPORTANT SAFETY INSTRUCTIONS
READ BEFORE INSTALLING

1) SAVE THESE INSTRUCTIONS

This manual contains important instructions for the EDP70 PLUS which should be followed during installation and maintenance of the UPS and associated batteries.

- 2)** The installation must be inspected by trained technicians.
The instructions must be followed.
- 3)** When external batteries are provided by the Customer and not Chloride, reference must be made to
the installation instructions provided by the battery supplier.

WARNINGS

- 1)** The AC and DC supplies to the EDP70 PLUS UPS and the AC output from the UPS **MUST** be fed through suitably rated circuit breakers or fuses and isolating switches suitable for branch circuit operation.
- 2)** Any external battery cabinet connected to the UPS **MUST** be provided with an over-current protection device per UL1778 Par. No. 10.4
- 3)** To reduce the risk of fire or electric shock, the equipment must be installed indoors, in a humidity and temperature controlled environment which is free from conductive contaminants.

SAFETY

- 1)** **DO NOT REMOVE COVERS DURING NORMAL OPERATION.** The panels will be removed during installation, however this should only be undertaken by qualified technicians. It should be ensured
that the UPS is switched off and that all power sources are disconnected (A.C. mains and Battery) before either the rear or side panels are removed.
- 2)** **FOREIGN OBJECTS MUST NOT BE INTRODUCED INTO THE VENTILLATION GRILLES.**
HAZARDOUS VOLTAGES are present within the EDP70 PLUS even when it is switched off.
- 3)** Fuses must **ONLY** be replaced with the same type and rating.
- 4)** The EDP70 PLUS contains a battery which can be **DANGEROUS** if interfered with. Contact the supplier for replacement.
- 5)** The UPS and/or its components must be disposed of as notifiable waste in accordance with local pollution control (special waste) regulations.

WARNING



The UPS contains hazardous voltages, even when all switches are open. In case of fire in the installation area, do not use water to extinguish fire.

ELECTRICAL PRECAUTIONS:

If the UPS is in By-pass mode and the Output switch is closed, no indications will be displayed; **fans will however function, and hazardous voltages are present downline from the static switches.**

EMERGENCY PROCEDURE

In the case of an emergency, the load supply can be interrupted by switching off all the switches fitted in the UPS.



ELECTRIC SHOCK

Switch off power; use dry insulating material for protection when pulling the injured person clear of conductors.

NEVER TOUCH THE INJURED PERSON WITH BARE HANDS UNTIL CLEAR OF CONDUCTORS. SEEK QUALIFIED ASSISTANCE IMMEDIATELY.



INJURIES CAUSED BY CONTACT WITH CORROSIVE LIQUIDS

In normal conditions, installed batteries are sealed. A damaged battery container may however leak electrolyte, or cause the latter to come into contact with battery parts.

In the event of electrolyte contact with the eyes, rinse eyes thoroughly with a saline solution or fresh water for at least 10 minutes.

In the event of electrolyte contact with skin, rinse the affected area with abundant water. Remove contaminated clothing. Cover affected area with dry gauze.



If electrolyte is swallowed, do not induce vomiting. Administer large quantities of milk or water.

IN ALL CASES, SEEK MEDICAL ATTENTION IMMEDIATELY

Contents

1.0 INTRODUCTION	6
1.1 Summary of the manual.....	6
1.2 Summary of the equipment	6
1.3 Block diagram.....	6
1.4 Functions	8
1.5 Operational modes	9
2.0 SAFETY	11
2.1 General safety.....	11
2.2 Symbols	11
2.3 Electrical precautions	12
2.4 Battery precautions.....	12
2.5 Battery safety equipment.....	12
3.0 STORAGE	13
4.0 INSTALLATION	13
4.1 Mechanical characteristics.....	13
4.2 Installation	21
Recommended wire sizes.....	22
4.4 Ventilation	24
5.0 CONNECTION	25
5.1 Electrical connections.....	28
5.2 24 – 12/18/24kVA.....	29
5.3 36 – 24/30/36kVA.....	32
5.3 EDP70 PLUS 50/80kVA.....	35
5.4 Signal connections.....	38
6.0 CONTROLS	39
6.1 User Controls.....	39
6.2 Control Panel.....	40
7.0 START UP	41

Figures

Figure 1 – Block diagrams – 24/36kVA	7
Figure 2 – Block diagram – 50/80kVA	8
Figure 3 – Normal operation	9
Figure 4 – Utility Supply failure	9
Figure 5 – Re-establishing the Utility Supply	10
Figure 6 – Transferring the Load onto the Reserve Supply	10
Figure 7 – 24 Footprint and cabinet dimensions	14
Figure 8 – 36 Footprint and cabinet dimensions	15
Figure 9 – 50/80 Footprint and cabinet dimensions	16
Figure 10 – “A” Battery Cabinet Drawing for 24/36kVA Ratings.....	17
Figure 11 – “B” Battery Cabinet Drawing for 24/36kVA Ratings.....	18
Figure 12 – “E” Battery Cabinet Drawing for 50/80kVA Ratings.....	19
Figure 13 – “F” Battery Cabinet Drawing for 50/80kVA Ratings.....	20
Figure 14 – UPS Ratings	21
Figure 15 – Connection diagrams	25
Figure 16 - 24 – 12/18/24kVA: Switches and Breakers	29
Figure 17 - 24 – 12/18/24kVA: Switches	30
Figure 18 - 24 – 12/18/24kVA: Cable Connections	31
Figure 19 - 36 – 24/30/36kVA: Switches and Breakers	32
Figure 20 - 36 – 24/30/36kVA: Connections.....	33
Figure 21 - 36 – 24/30/36kVA: Cable Connections	34
Figure 22 – 50/80kVA: Switches and Breakers	35
Figure 23 – 50/80kVA: Connections.....	36
Figure 24 – 50/80kVA: Cable Connections	37
Figure 25 – Control panel	39

1.0 INTRODUCTION

1.1 Summary of the manual

This handbook provides for the safe installation, startup and use of the EDP70 PLUS Uninterruptible Power System (UPS). The Company recommends that the equipment be installed and regularly maintained by a Chloride Authorized personnel.

- DO:**
- read the User Handbook before operating the EDP70 PLUS UPS.
 - keep a log of all incidents.
 - protect the batteries from damage. Batteries leak acid; avoid contact with skin, clothes or eyes.

- DO NOT:**
- operate the control switches.
 - operate the EDP70 PLUS UPS with any covers removed.
 - obstruct the ventilation grilles.

1.2 Summary of the equipment

The EDP70 PLUS Uninterruptible Power System (UPS) totally isolates the load from voltage drops, spikes, transients frequency variations in the utility supply.

In the event of failure or brownout of the AC utility supply, an internal audible alarm sounds and an LED on the control panel illuminates, the EDP70 PLUS UPS will continue to provide safe, clean continuous power, without interruption, from the battery, for a duration dependent on battery capacity and output load.

The audible alarm alerts the user to start a safe orderly shutdown of the load. When the AC utility supply returns to normal, the EDP70 PLUS UPS automatically recharges the battery ready for any future power failure.

The microprocessor display panel provides access to very detailed information regarding the status of the supplies and EDP70 PLUS UPS. Refer to current publication for detailed specification.

The block diagram, shows the main functional sub-assemblies of the EDP70 PLUS UPS. The AC three phase utility supply is rectified to provide direct current, which maintains the battery in a fully charged state and also supplies the inverter, which provides the three phase output via an electronic static switch.

Normally the supply of the reserve line is taken from the AC utility input, but special units, with a separate reserve input supply, are available. This allows the inputs to be supplied from independent three phase sources.

Provided the reserve supply is within limits, the inverter will match the output frequency with the reserve supply frequency. The inverter has its own internal crystal control to stabilize the output frequency if the reserve supply frequency is out of limits. The electronic static switch switches the output from the inverter to the reserve supply, without interruption, to meet any load current surges, or to supply the load if the battery is discharged during an AC utility supply failure.

Maintenance and testing can be carried out on the EDP70 PLUS UPS without interrupting the output, by switching the load from the reserve supply to the maintenance bypass circuit. This work should only be carried out by Chloride-trained personnel.

1.3 Block diagram

24kVA - STANDARD CONFIGURATION

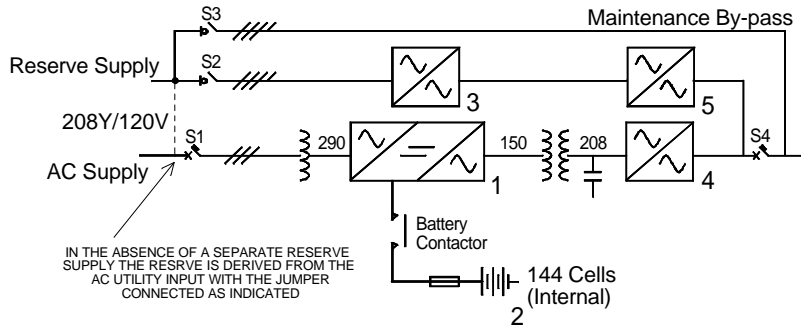

36kVA - STANDARD CONFIGURATION

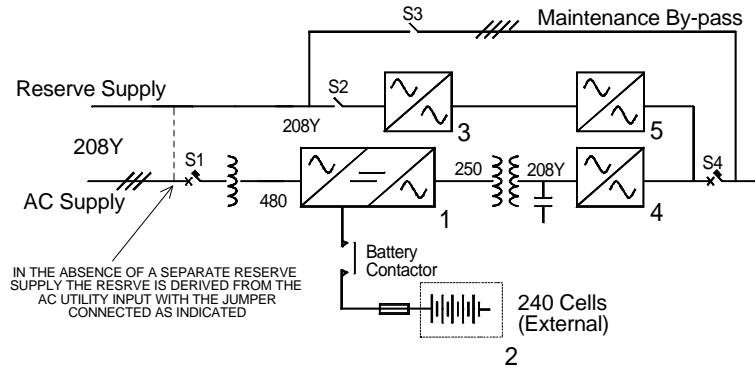

36kVA - 480V/208V CONFIGURATION

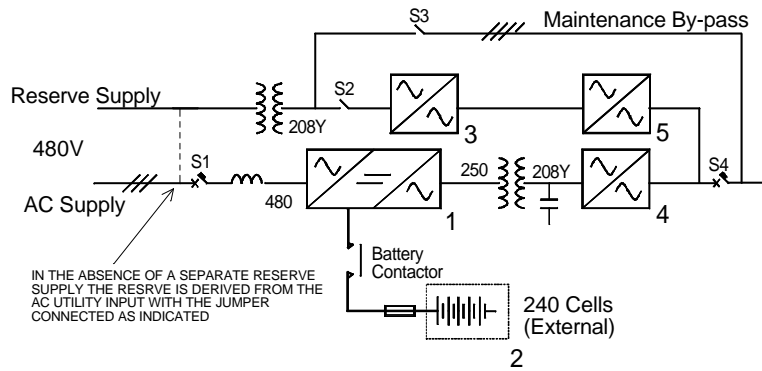

Figure 1 – Block diagrams – 24/36kVA

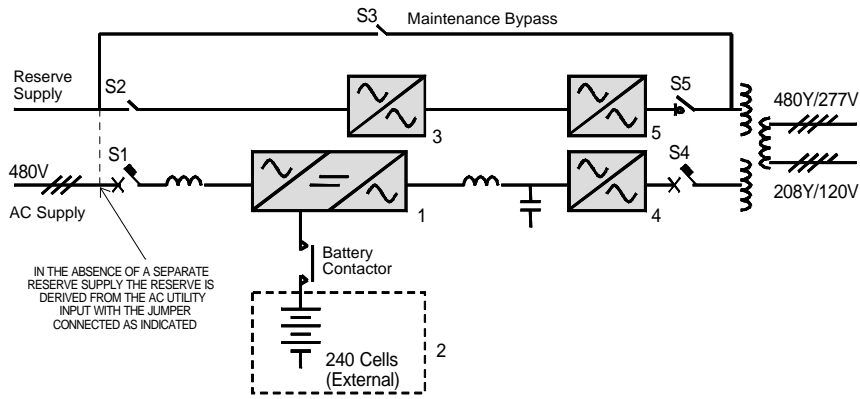

Figure 2 – Block diagram – 50/80kVA

The uninterruptible power system consists of the following:

- | | |
|----------------------------|--|
| 1 - RECTIFIER/INVERTER | S1 = Equipment ON/OFF switch |
| 2 - BATTERY | S2 = Equipment Reserve switch |
| 3 - BACKFEED PROTECTION | S3 = Equipment By-pass switch |
| 4 - INVERTER STATIC SWITCH | S4 = Equipment OUTPUT switch
(INVERTER OUTPUT switch for 50/80kVA only) |
| 5 - RESERVE STATIC SWITCH | S5 = RESERVE OUTPUT switch for 50/80kVA only |

1.4 Functions

RECTIFIER / BATTERY CHARGER

The rectifier/battery charger transforms the alternating current of the mains supply to direct voltage to maintain the battery in a fully charged state and also supply the inverter.

BATTERY

The battery is an energy reserve that is used by the inverter and the load whenever the mains supply fails.

INVERTER

The inverter changes the direct voltage from the rectifier or from the battery into a three phase sinusoidal alternating voltage for the external supply.

ELECTRONIC STATIC SWITCH

The function of the electronic static switch is to select one of the two sources of alternating voltage and to supply it to the external load. The two sources of voltage supplied to the static switch are the output of the inverter and the reserve supply. In normal working conditions, the static switch supplies the load from the inverter.

SWITCHES

The switches permits maintenance and repair of the UPS, without interrupting the supply to the load.

1.5 Operational modes

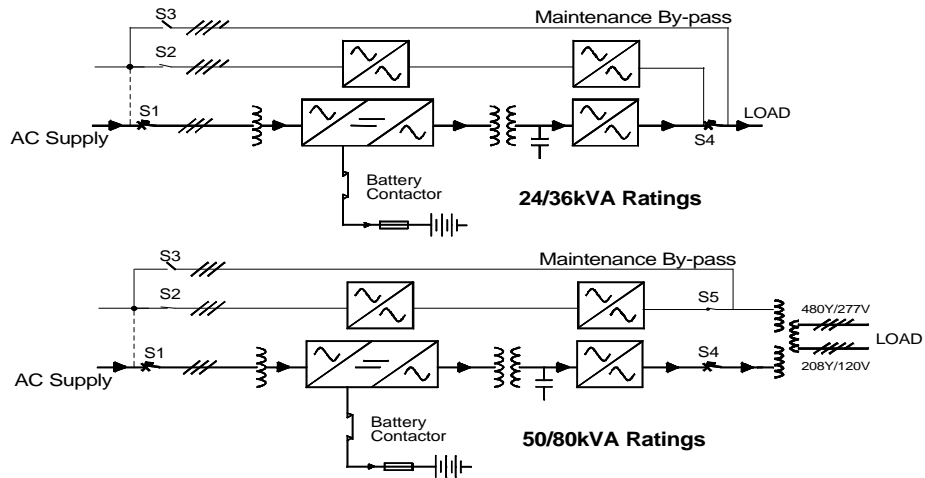

Figure 3 – Normal operation

During normal operation the load is supplied by the mains through the rectifier and inverter. The rectifier also supplies the current for recharging and maintaining the battery in a fully charged state.

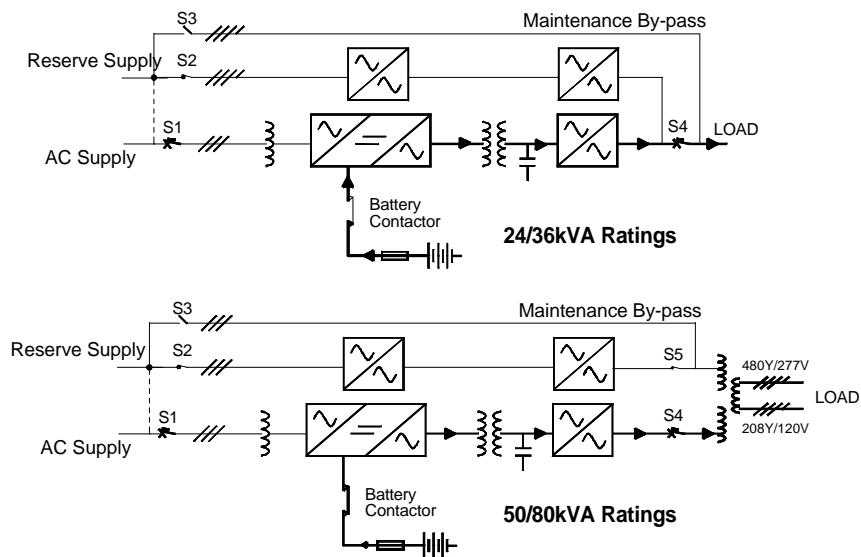

Figure 4 – Utility Supply failure

When the utility supply voltage is absent or outside the allowed tolerances, the battery supplies the inverter. This will be indicated on the UPS front panel display and the Remote Alarm Unit (if fitted). The standby time available depends both on the capacity of the battery and on the size of load. It is possible to extend autonomy by reducing the output power by disconnecting non-important loads. In all cases, the alphanumeric display shows the residual autonomy.

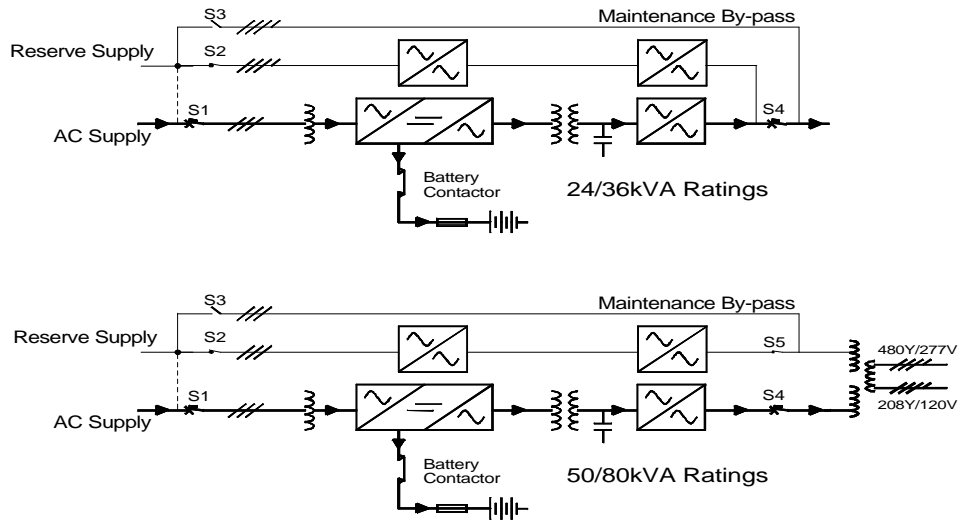

Figure 5 – Re-establishing the Utility Supply

When the utility supply returns within acceptable limits, the UPS returns automatically to normal operation mode as previously described. The rectifier now starts to recharge the battery. However, until recharge has been completed, any further mains failure will result in reduced standby times.

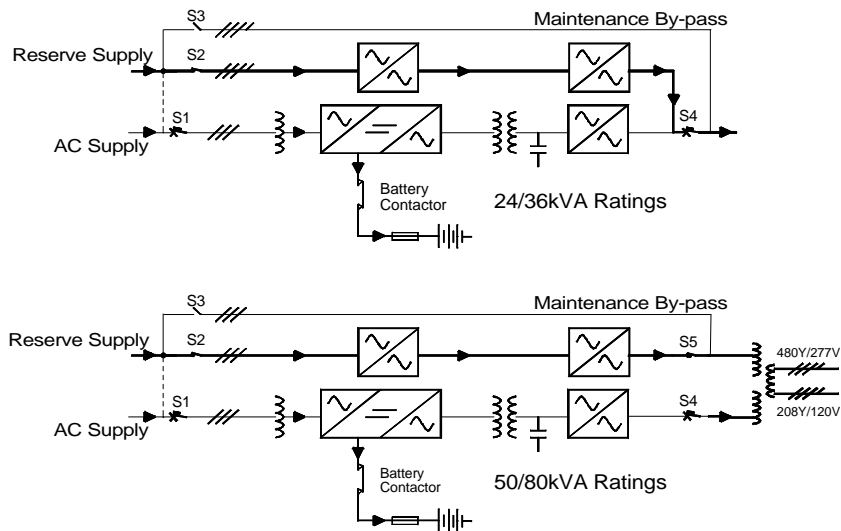

Figure 6 – Transferring the Load onto the Reserve Supply

Transfer onto the reserve line is caused by two conditions:

- a) inverter stop
- b) overload

In both instances the load is transferred onto the reserve without interruption. If the overload is temporary, the system will re-transfer from reserve to inverter as soon as it ceases. This allows for the initial start-up of loads with high or excessive switch-on currents.

2.0 SAFETY

Read all instructions carefully before installing or operating the equipment.

2.1 General safety

The procedure described in these instructions is intended for use by persons experienced in the operation of Uninterruptible Power Systems and ancillary equipment.

Persons unfamiliar with this type of equipment should seek guidance from experienced personnel.

The EDP70 PLUS UPS is designed to be operated in accordance with existing safe operating procedures.

These instructions are not intended to replace existing safety practices.

If there are any questions regarding the safe operation of the system, contact a Chloride service representative.

This equipment is designed and built for safe operation when used to supply its rated load, providing it is installed as specified by qualified, licensed and competent electricians.

Electrical energy can be supplied by the equipment and the battery.

2.2 Symbols

The following symbols appear in this book and in the unit:



Warning - Hazardous voltages are present. If the instructions are not heeded, there is a risk of electrical shock and danger to personal safety.



DIRECT CURRENT SUPPLY



ALTERNATING CURRENT SUPPLY



ON position of the switches



OFF position of the switches



Inverter Start Up

For explanation see Para. 6.2. of this manual



Inverter Shutdown

For explanation see Para. 6.2. of this manual



Audible Alarm Cancel Switch

For explanation see Para. 6.2. of this manual



Page Right Control

For explanation see Para. 6.2. of this manual



Record Up

For explanation see Para. 6.2. of this manual



Record Down

For explanation see Para. 6.2. of this manual

2.3 Electrical precautions

Never handle a component or assembly without first confirming that no voltage is applied or present. Remove only those protective covers that are essential to perform the repairs or adjustment currently required, and replace them as soon as possible.

- . Use only insulated tools.
- . Place a rubber insulating mat in front of all equipment doors.
- . Keep all door closed and locked at all times during normal operation.

2.4 Battery precautions

Always isolate the load before connecting or disconnecting the batteries or battery cells. Ensure that batteries are fully isolated by disconnecting the battery connectors, opening circuit breakers, or both. Remove all jewellery from hands, wrists and neck before working on batteries or battery cells. Before leaning over batteries, remove any metal object that could fall out of pockets. Do not place tools or other conductive objects on the batteries.

2.5 Battery safety equipment

When working on or handling batteries, ensure that the following items are worn:

- . Eye goggles
- . Rubber gloves
- . Rubber apron
- . Rubber boots

When batteries are being moved or worked on, ensure the following items are available in the immediate vicinity:

- . An eye bath, eyewash station or equivalent
- . A clean water source to wash spilled acids
- . Absorbent materials to soak up spilled acids
- . Disposal for contaminated materials.

3.0 STORAGE

If the EDP70 PLUS UPS cannot be installed within sixty days of delivery, there is a danger of the integral battery becoming discharged thereby sustaining permanent damage and affecting the standby period available and battery life. The date the battery was last recharged and the date the battery is due for its next recharge are both stamped on the packaging accompanying the unit. If you intend to store the unit, please refer to the recharge date.

When the EDP70 PLUS is due to be recharged, refer to the Installation instructions and connect the EDP70 PLUS UPS to a temporary AC supply. The battery MUST be recharged for at least 24 hours every 3 months.

4.0 INSTALLATION

4.1 Mechanical characteristics

- Ambient temperature 18°F[-10°C] to 104°F [+40°C]
- Relative Humidity (w/out condensing @ 68°F[20°C]) < 90%
- Max altitude (w/out derating) 3300 feet [1000 m] above sea-level
- Protection degree (panel fitted)
- Input cables bottom
- Air inlet bottom
- Air outlet rear

			UPS model			
Description		u.m.	24	36	50	80
Size	width depth height	In [mm]	27.5 [700]	27.5 [700]	35.4 [900]	35.4 [900]
			28.7 [730]	28.7 [730]	28.7 [730]	28.7 [730]
			56 [1420]	56 [1420]	63 [1600]	63 [1600]
Total Weight (UPS + Battery)	w/out cells	Lbs [kg]	880 [400]	1300 [590]	1342 [610]	1800 [818]
	25 Ah cells		1342 [610]	n.a.	n.a.	n.a.
	30 Ah cells		1456 [662]	n.a.	n.a.	n.a.
	35 Ah cells		1526 [694]	n.a.	n.a.	n.a.
Floor Area		ln ² [m ²]	789 [0.511]	789 [0.511]	1019 [0.657]	1019 [0.657]
Floor Loading (UPS + Battery)	w/out cells	Lbs/in ² [kg/m ²]	1.12 [782]	1.65 [1155]	1.32 [930]	1.77 [1245]
	25 Ah cells		1.70 [1194]	n.a.	n.a.	n.a.
	30 Ah cells		1.85 [1296]	n.a.	n.a.	n.a.
	35 Ah cells		1.93 [1358]	n.a.	n.a.	n.a.
Air-Flow		cfm [mc/h]	235 [400]	647 [1100]		
Acoustic Noise 100% Linear Load		dBA	52	55		

- Notes:**
- 1) n.a. = not applicable
 - 2) Longer autonomies, and battery for EDP above 20 kVA are available with external battery cubicles.

ALL MEASUREMENTS ARE IN
MILLIMETERS (AND INCHES)

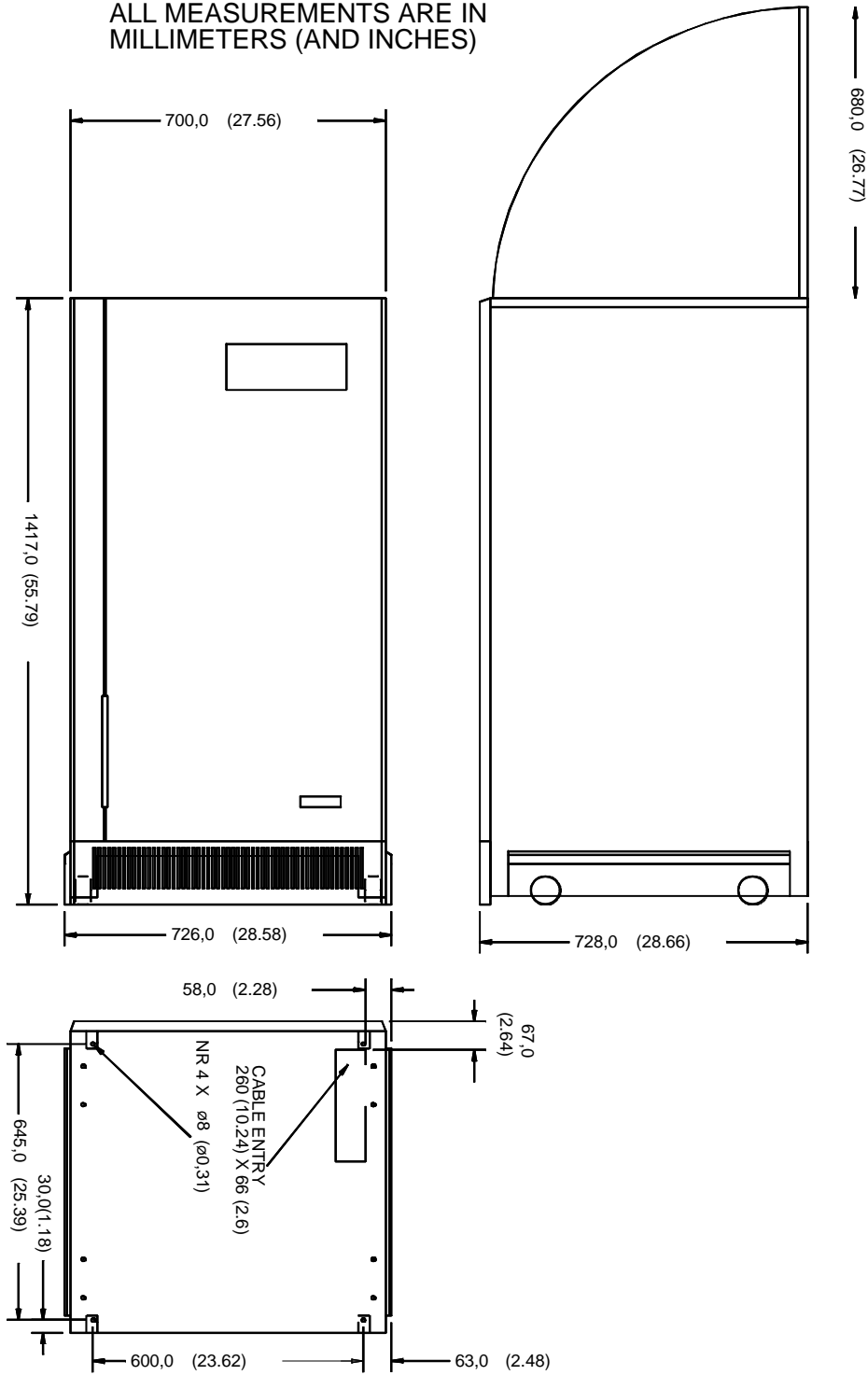

Figure 7 – 24 Footprint and cabinet dimensions

ALL MEASUREMENTS ARE IN
MILLIMETERS (AND INCHES)

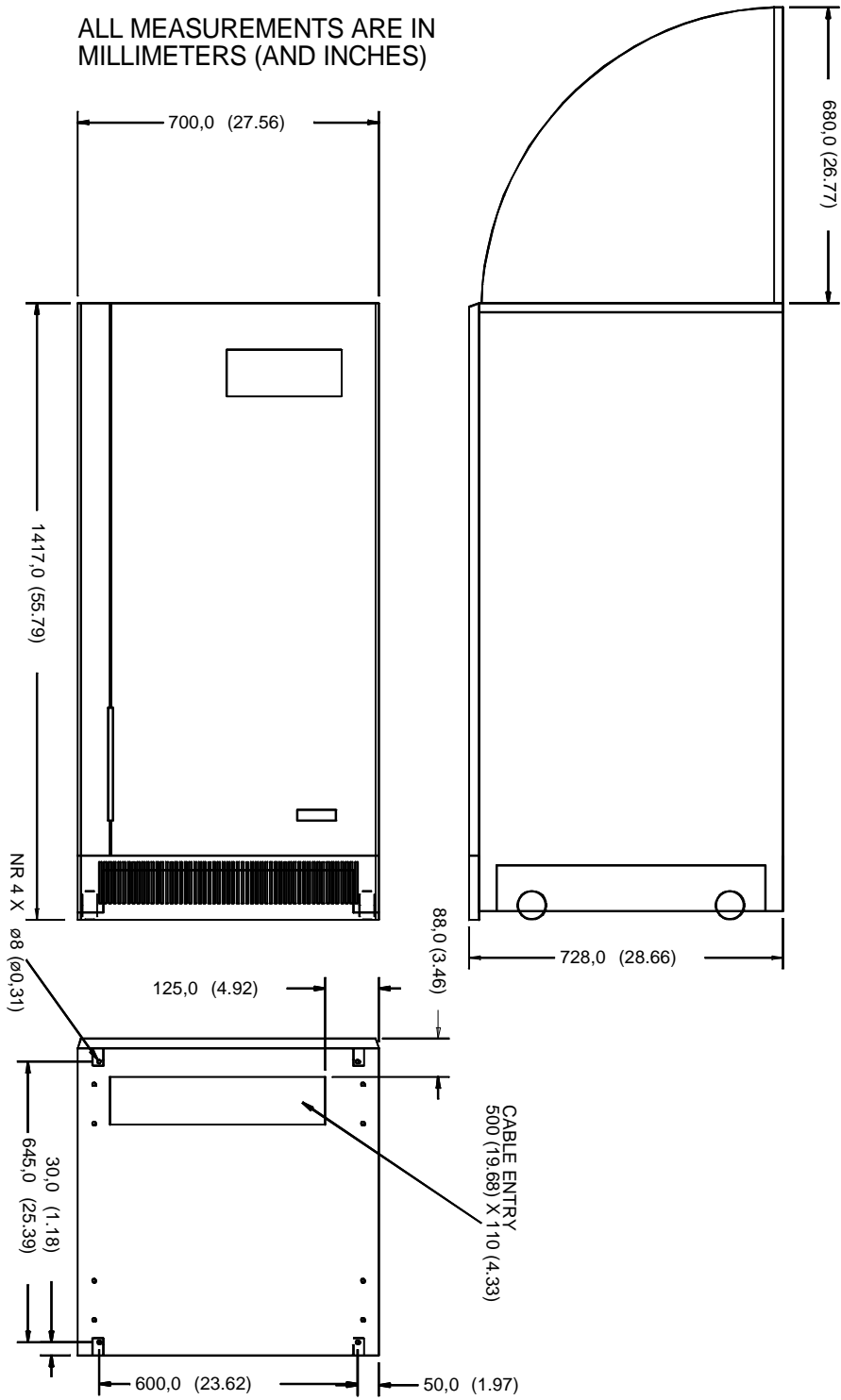

Figure 8 – 36 Footprint and cabinet dimensions

ALL MEASUREMENTS ARE IN
MILLIMETERS (AND INCHES)

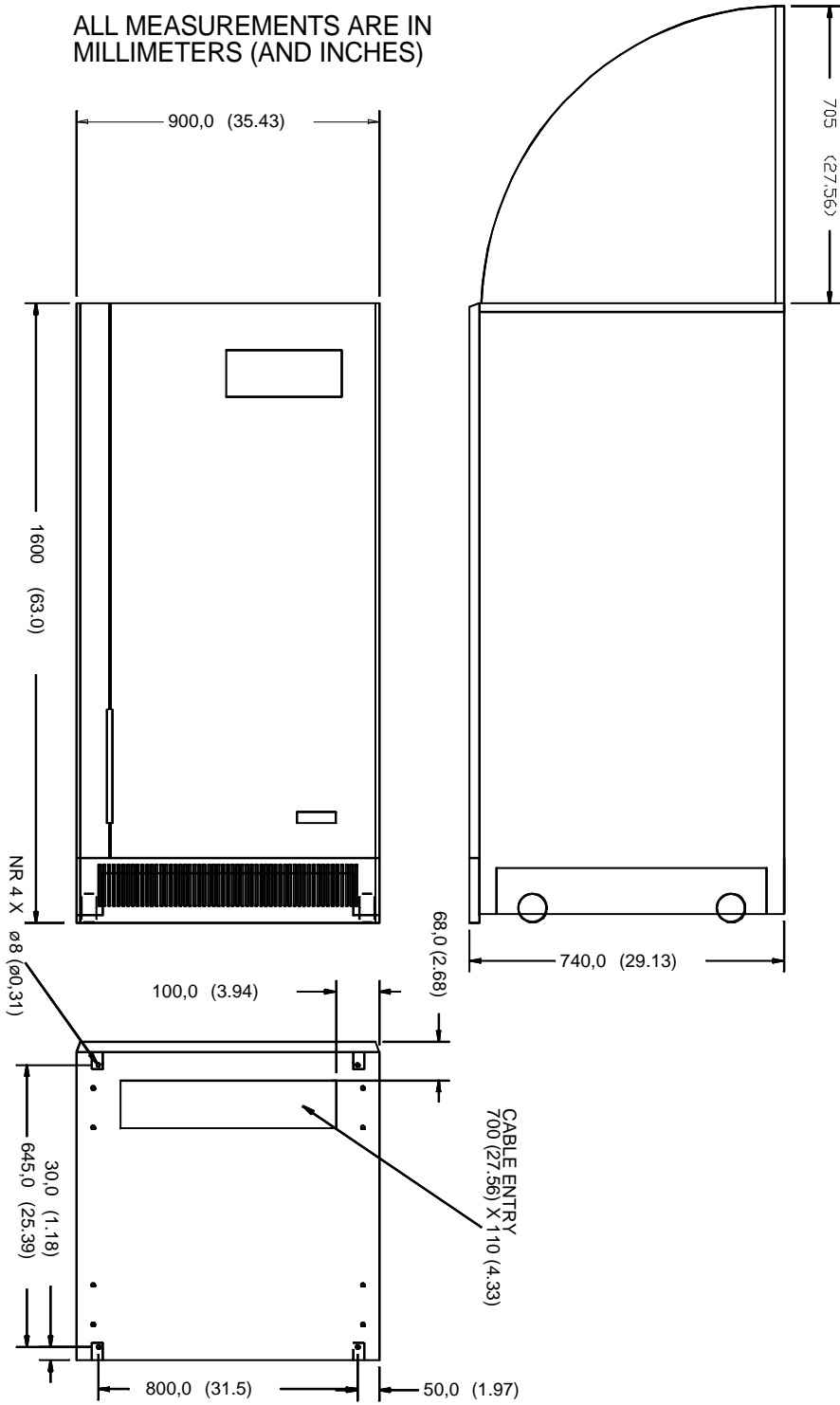

Figure 9 – 50/80 Footprint and cabinet dimensions

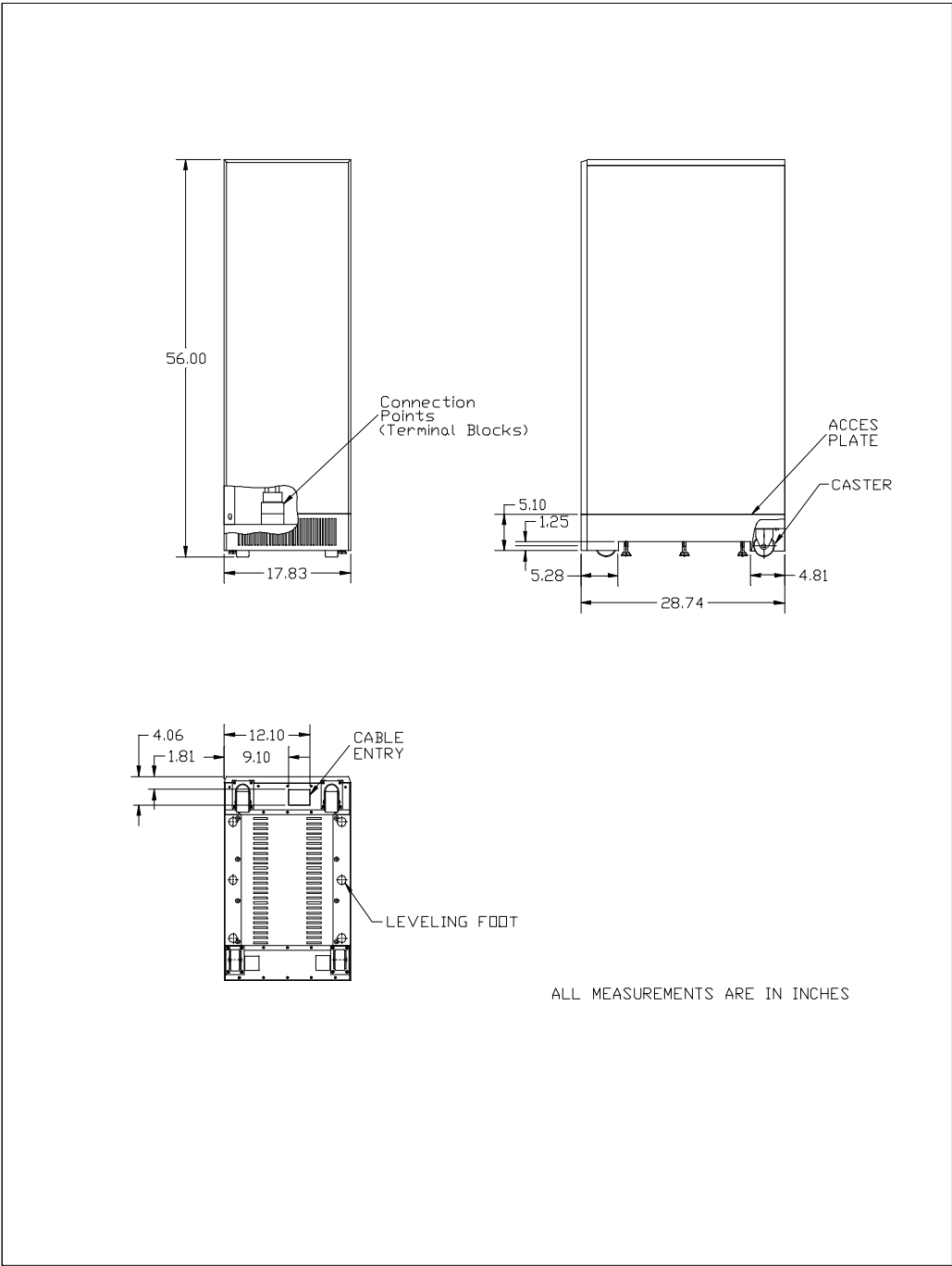

Figure 10 – “A” Battery Cabinet Drawing for 24/36kVA Ratings

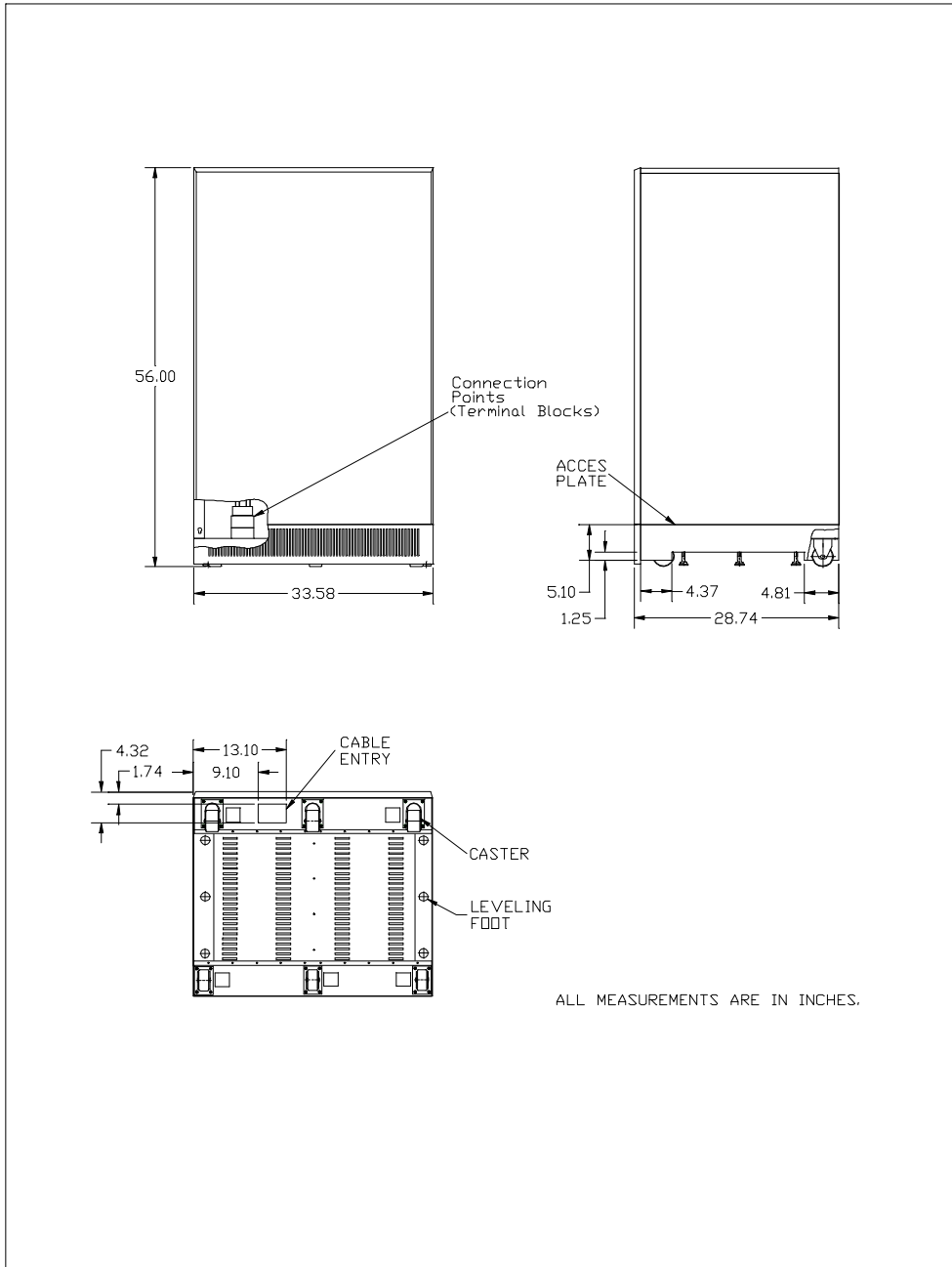

Figure 11 – “B” Battery Cabinet Drawing for 24/36kVA Ratings

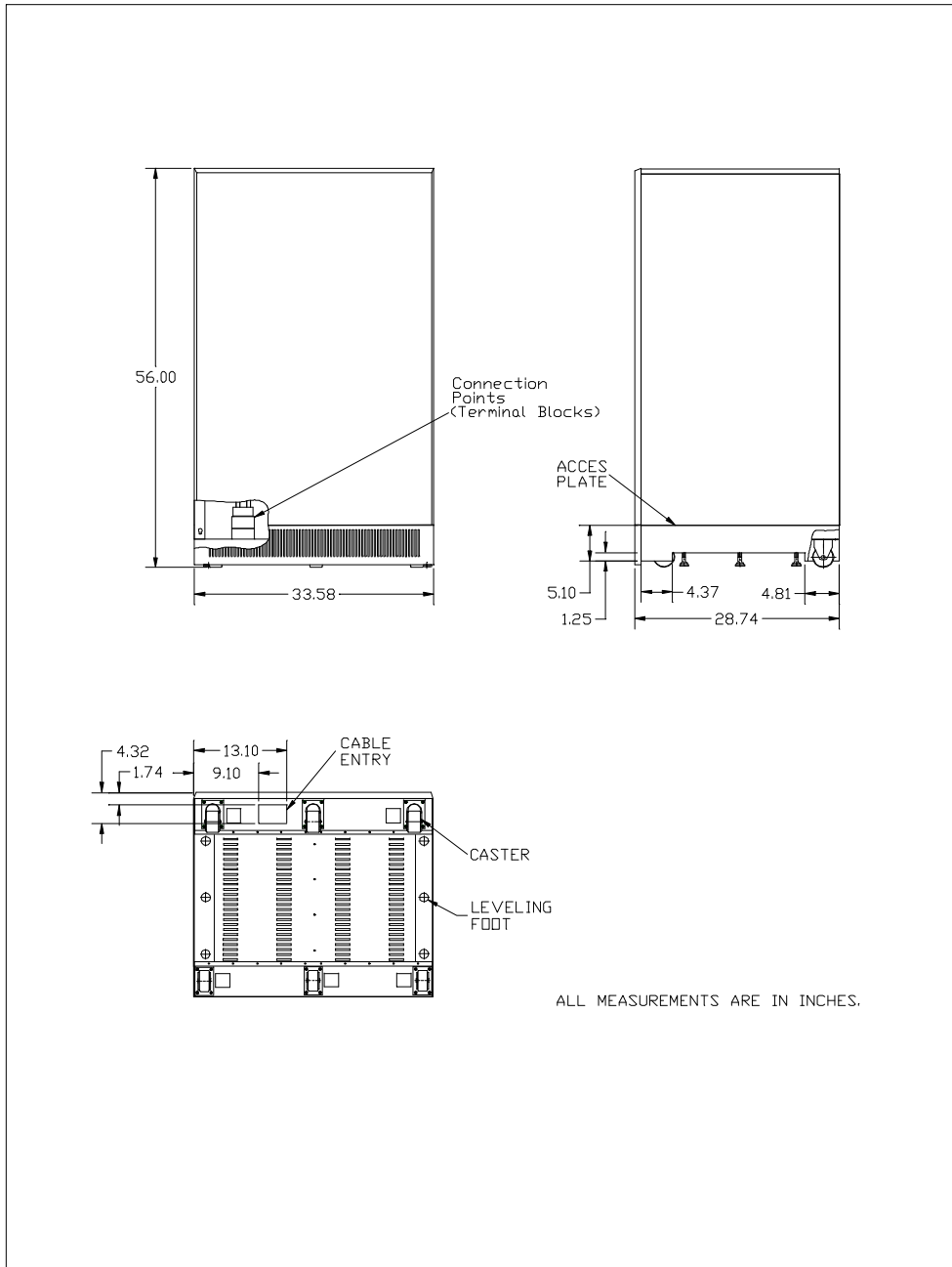

Figure 12 – “E” Battery Cabinet Drawing for 50/80kVA Ratings

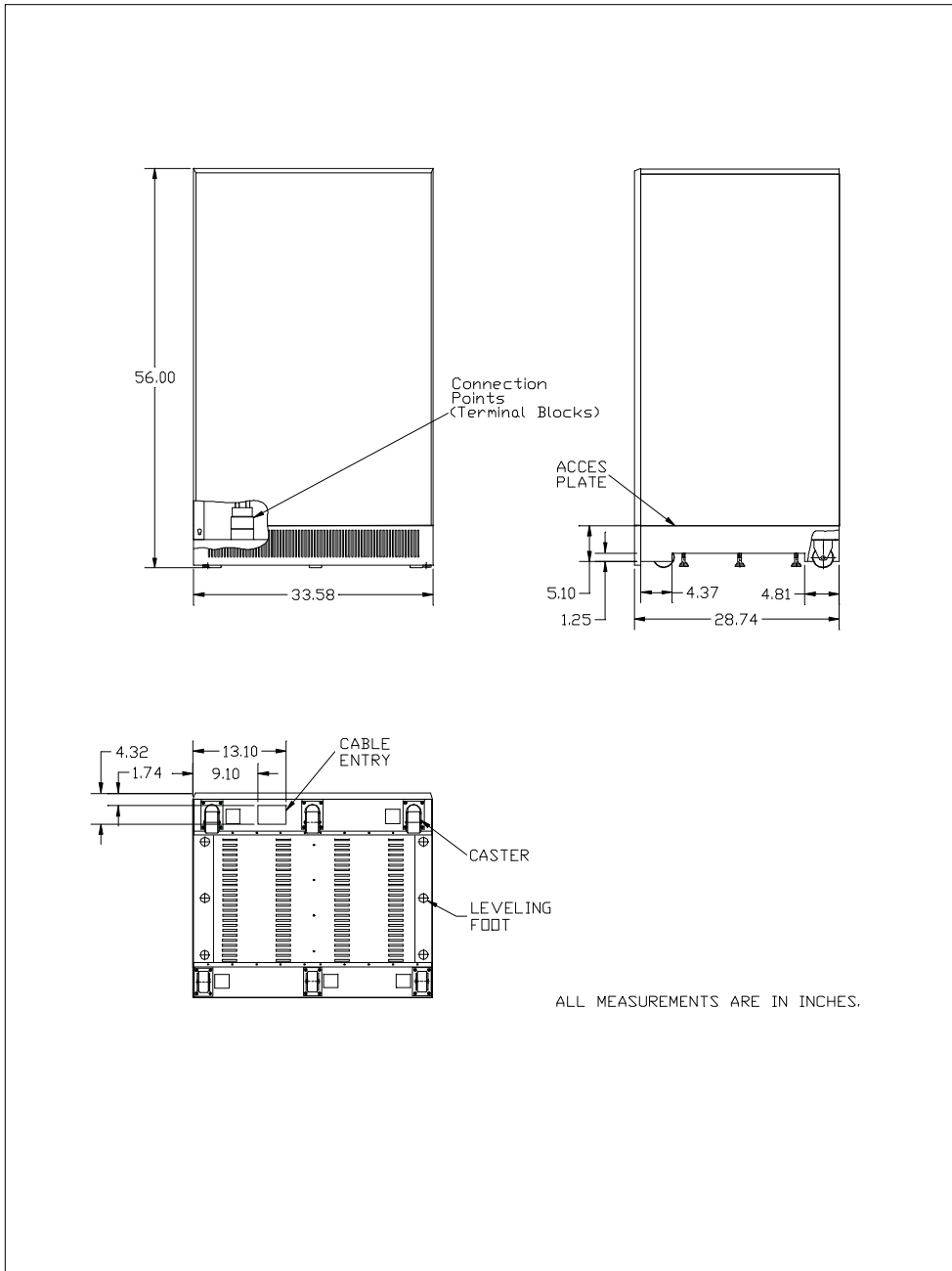

Figure 13 – “F” Battery Cabinet Drawing for 50/80kVA Ratings

4.2 Installation

Check the rating label on the rear of the front panel of the EDP70 PLUS UPS to ensure the input/output voltages, frequency and load are all within the rating of the UPS.

EDP70 PLUS is designed to operate in an office environment with an optimum temperature of 68°F [20 C].

A gap of at least 4In [10cm.] must be maintained at rear of the UPS to ensure adequate ventilation.

Nothing should be placed around the equipment which might restrict the airflow.

Ensure the interconnecting cables do not cause a hazard to the user.

A gap of at least 32 In [800 mm] must be maintained above the UPS to ensure adequate space for maintenance.

The appropriate lifting equipment must be used to move the EDP70 PLUS UPS.

Figure 14 – UPS Ratings

Description	U.M.	UPS ratings					
		24 12kVA	24 18kVA	24 24kVA	36 24kVA	36 30kVA	36 36kVA
Output power	kVA	12	18	24	24	30	36
Nominal Load	kW	8	12	16	16	20	24
Maximum input power (with unit @ nominal Load & battery recharge)	kVA	15	21	28	28	35	42
Maximum dissipation (with inverter @ nominal Load)	BTU/H	3750	5460	6800	7700	9500	11300
Number of battery cells	n	144			240		
Battery voltage range	V	238-327			396-545		
Battery end-discharge current	A	37	55	74	53	67	80

Description	U.M.	UPS ratings					
		50 30kVA	50 40kVA	50 50kVA	80 50kVA	80 65kVA	80 80kVA
Output power	kVA	30	40	50	50	65	80
Nominal Load	kW	24	32	40	40	52	64
Maximum input power (with unit @ nominal Load & battery recharge)	kVA	43	57	71	71	91	112
Maximum dissipation (with inverter @ nominal Load)	BTU/H			14300	14300	18600	22100
Number of battery cells	n	240					
Battery voltage range	V	396-545					
Battery end-discharge current	A	67	88	110	105	140	173

Recommended wire sizes

- 1)** It is recommended that the external cables and protection be selected for the highest rated unit of the model in use.

- 2)** Reserve (or primary) input and output Neutral cable size should be greater than that of the line cables in order to be able to supply non-linear loads having a Crest Factor of up to 3:1 (i.e. where neutral current = 1.7 x line current).
If non-linear loads are not to be supplied from the Installation, the Neutral can be of the same size as the load cable.

- 3)** Recommended AC input overcurrent protection represents 125% of nominal full load current (continuous) plus the short duration input current (non-continuous) for battery re-charging per NEC 220-10 b.

- 4)** UPS output cables should be run in separate conduits from input cables.

- 5)** Grounding conductors are sized per NEC 250-95.

- 6)** Cable sizes are based upon NEC.

Recommended sizes only. Be sure to follow the codes which apply to your installation.

Refer to UPS connection data table on following page.

UPS Type	V _{in} /V _{out}	A.C. Supply		Output	Reserve Supply	
		Rated current (A)	Protection device (A)	Nominal current (A)	Nominal current (A)	Protection device (A)
24/12kVA	208/208	42	50	33	33	50
24/18kVA		60	80	50	50	75
24/24kVA		78	100	67	67	100
36/24kVA	208/208	78	100	67	67	100
36/30kVA		97	100	83	83	125
36/36kVA		118	125	100	100	150
36/24kVA	480/208	34	45	67	30	45
36/30kVA		42	50	83	36	55
36/36kVA		51	70	100	43	65
50/30kVA	480/480	50	70	36	36	50
50/40kVA		66	90	48	48	80
50/50kVA		83	110	60	60	80
50/30kVA	480/208	50	70	83	36	50
50/40kVA		66	90	111	48	80
50/50kVA		83	110	139	60	80
80/50kVA	480/480	83	110	60	60	80
80/65kVA		110	125	78	78	100
80/80kVA		135	150	96	96	125
80/50kVA	480/208	83	110	139	60	80
80/65kVA		110	125	180	78	100
80/80kVA		135	150	222	96	125

4.4 Ventilation

UPS can work in a continuous environment within 18°F[-10°C] to 104°F [+40°C] temperature range, although, ideally the ambient temperature should be below 78°F [25°C].

The heat, dissipated by the UPS (indicated on figure 7), is extracted by internal fans and then dissipated into the air.

The heat can be removed from the UPS room by a forced cooling ventilation system or, alternatively, an air conditioning system.

The required air changes per hour will depend on the UPS rating and this heat loss and on the cooling air temperature.

To calculate the required air flow for the dissipated power, the altitude and the cooling air temperature, the following equation can be used:

$$V = 2770 \frac{P_d}{T_r - T_k} \cdot e^{(0.125 h T_k / T_0)}$$

- with:
- V = air flow [mc/h]
 - P_d = total dissipated power [kW]
 - T_r = max. temperature allowed into the room [104°F = 40°C = 313°K]
 - T_k = Temperature of input cooling air
 - T₀ = 273 °K
 - h = altitude above the sea level [km]

5.0 CONNECTION

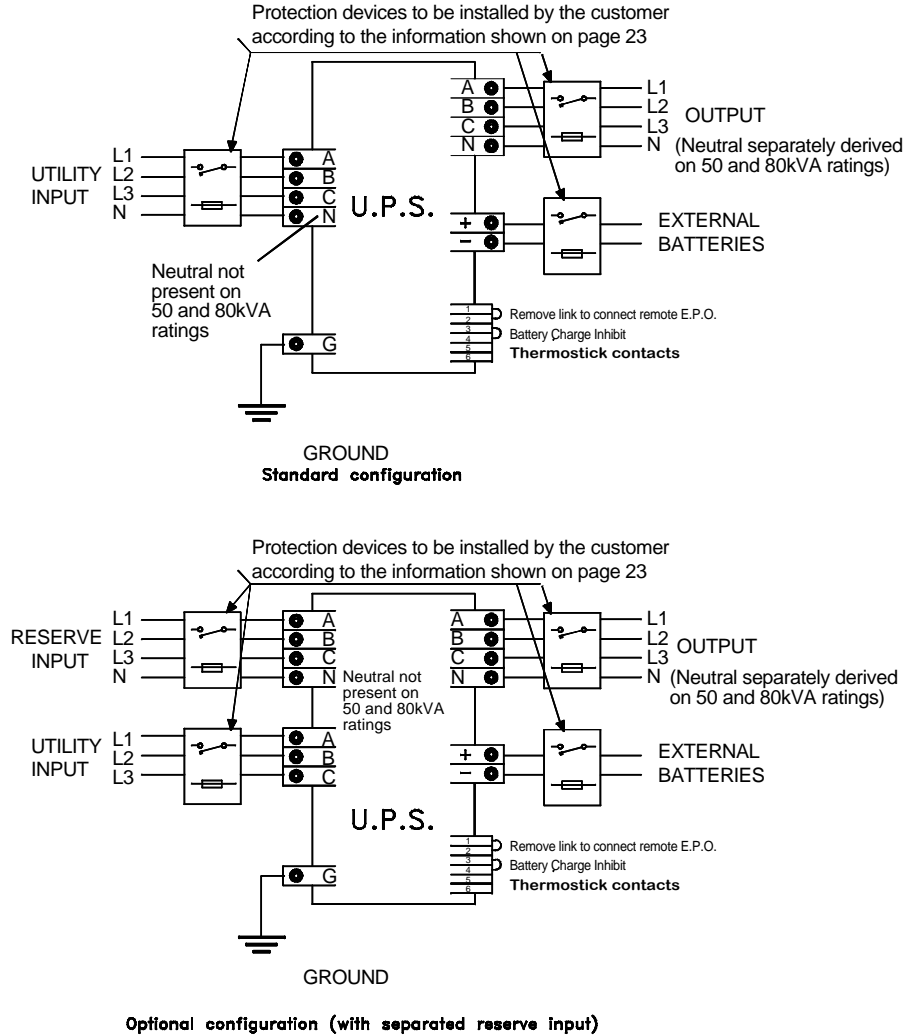

Figure 15 – Connection diagrams

THE AC AND DC SUPPLIES TO THE EDP70 PLUS UPS, AND THE AC OUTPUT FROM THE UPS, SHOULD BE FED THROUGH SUITABLY RATED CIRCUIT BREAKER OR FUSE(S) AND ISOLATING SWITCH SUITABLE FOR BRANCH CIRCUIT PROTECTION.

NOTE: INTERRUPTING THE NEUTRAL FEED MAY CAUSE THE CHANGE IN GROUND-NEUTRAL VOLTAGE TO AFFECT THE LOAD.

NOTE: ALL CIRCUIT BREAKERS OR FUSES AND ISOLATING SWITCHES SHOULD BE FITTED AS CLOSE TO THE EDP70 PLUS UPS AS POSSIBLE AND MARKED WITH THE LABELS PROVIDED WITH THE UNIT. IT IS ALSO RECOMMENDED A LABEL AS FOLLOWS

**UNINTERRUPTIBLE POWER SYSTEM
NO UNAUTHORIZED OPERATION**

CAUTION!

All power connection must be carried out by qualified licensed personnel experienced in wiring this type of equipment

The safety ground wire must be connected before the power input cables

The correct phase rotation (phase A leads B leads C) must be observed on the UPS terminals.

An input grounded neutral conductor is required (24/36kVA only)

WARNING!

In maintenance by-pass operation, the UPS components are de-energized, with the exception of input/output terminals, battery cabinet, input matching voltage transformer (for 480/208 configuration) and isolating transformer (for 50 and 80kVA). All input power (AC and DC) must be disconnected to ensure complete isolation

5.1 *Electrical connections*

WARNING!
**All electrical connections must
be made by a qualified electrician
and meet local electrical code standards**

Before attempting to connect the mains supply, the reserve/bypass supply or the load, ensure that all supplies, including the battery, are isolated and that all the equipment switches are in their »OFF« position. Open UPS front access panel and remove internal panel over main switches and terminal blocks.

NOTES: 1) In accordance with para. 12.7 of UL 1778, the installation must be performed by a qualified electrician. The terminals require the use of the proper crimp tools and terminals in order to perform an installation in accordance with the National Electrical Code (NEC). The recommended crimp tools, terminals and torque are shown in the followings tables:

2) **Use Copper Conductors Only**

Table of T& B's cat.no.s for terminals and crimp tools

5.2 24 – 12/18/24kVA

Ensure the AC supplies and load are switched OFF. Check that **all the EDP70 PLUS UPS Switches** (behind the front panel) are switched OFF, see Figure 16 .

The AC supply cables must be suitable for carrying the maximum supply demand. The voltage drop in the cable should be minimized to ensure the AC supply voltage at the EDP70 PLUS UPS terminals is within +/- 10% of nominal.

The EDP70 PLUS UPS should be connected to the main/reserve supplies and output load via a wall mounted junction box.

Installation and connection should only be carried out by qualified electrical personnel.

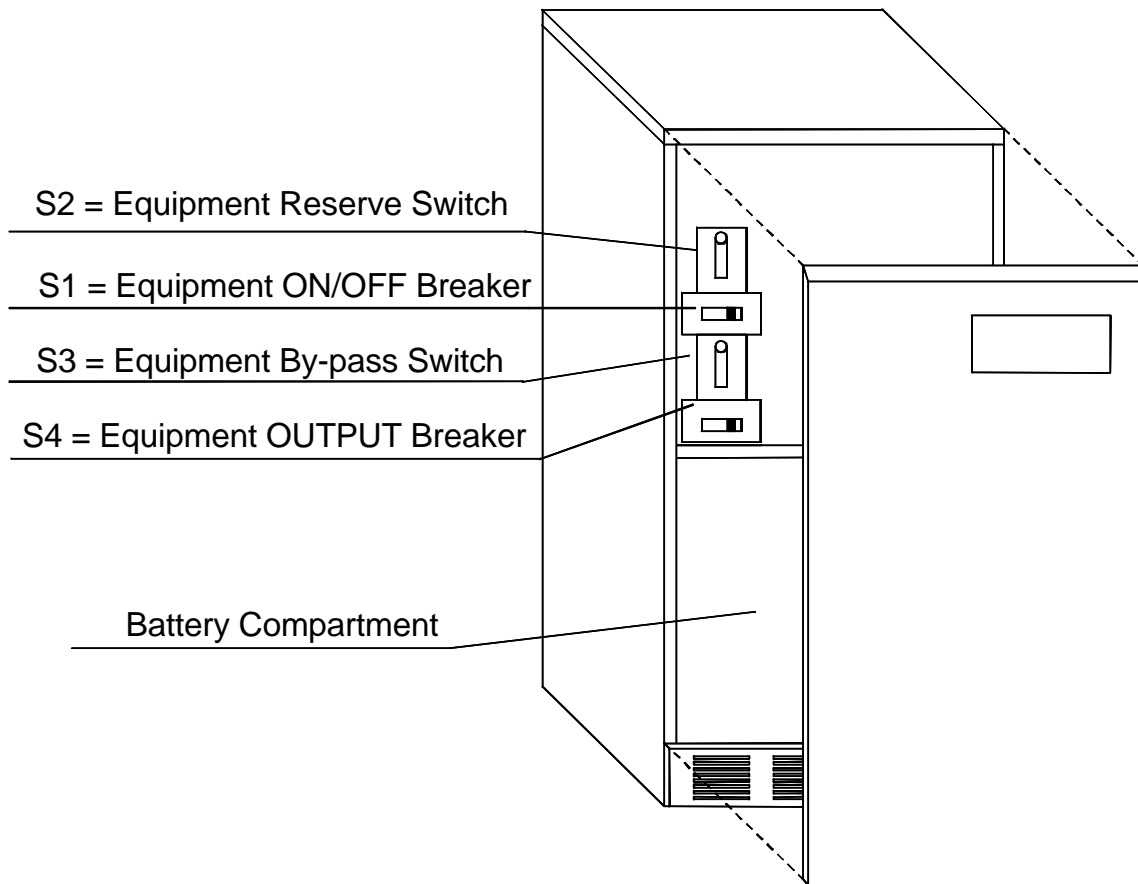

Figure 16 - 24 – 12/18/24kVA: Switches and Breakers

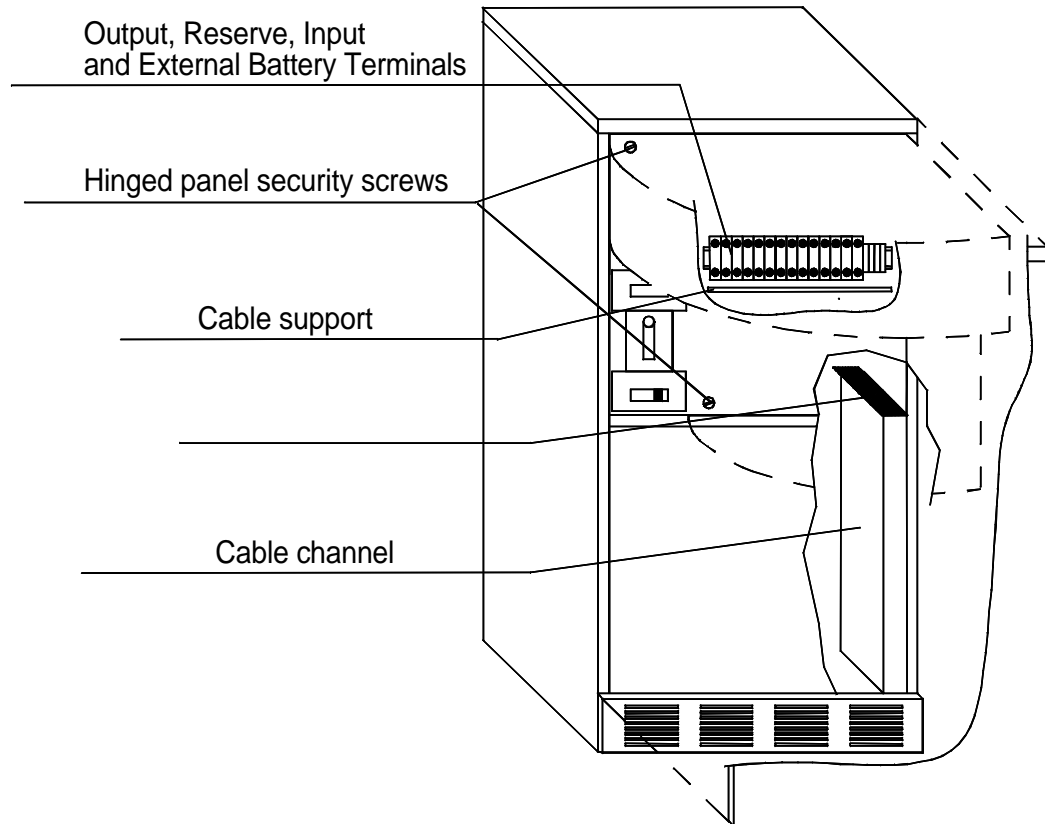

Figure 17 - 24 – 12/18/24kVA: Switches

Access to the terminals for electrical connections is as follows:

- a) Remove front panel see Figure 16.
- b) Remove the two securing screws for the hinged front panel.
- c) This exposes the electrical terminal rail, see Figure 18
- d) Remove the screws securing the access plate.
- e) Push the interconnection cables up through the cable channel and the access plate.
- f) Release the terminal securing nuts by unscrewing fully anti-clockwise. All cables must be terminated with the correct size lugs and connected on the bottom side terminals as marked.
- g) Install or start-up batteries see section 13.1
- h) Replace and tighten the terminal securing screws fully clockwise and refit the access plate.
- i) Replace the terminal board compartment panel and the front cover.

OBSERVE POLARITIES AND ORIENTATIONS.

See Remote Alarms and Computer Interface for connections to these facilities. For optional battery cubicles, refer to section 13.2.

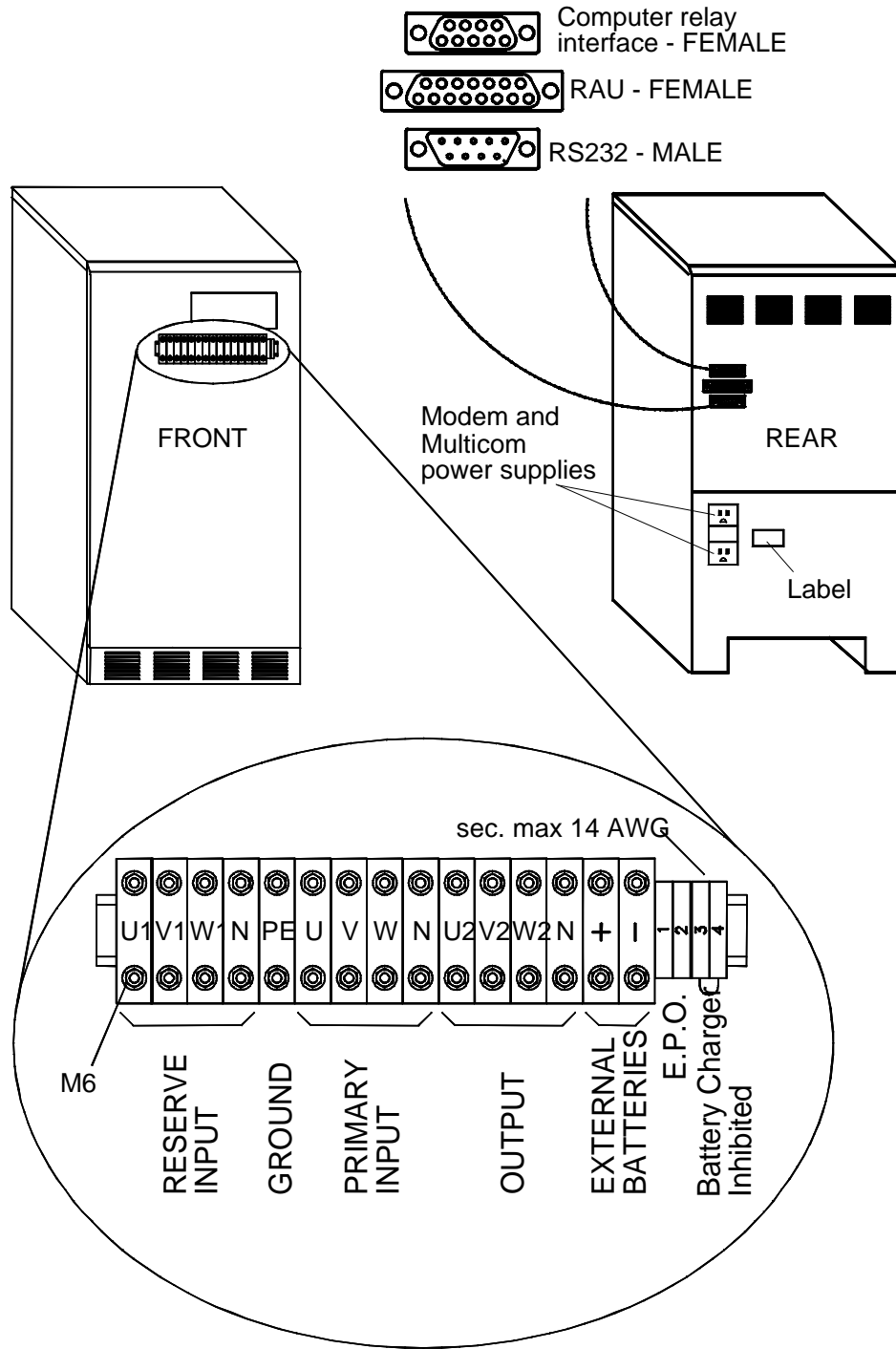

Figure 18 - 24 – 12/18/24kVA: Cable Connections

5.3 36 – 24/30/36kVA

Ensure the AC supplies and load are switched OFF. Check that **all the EDP70 PLUS UPS Switches** (behind the front panel) are switched OFF, see figure 13.

The AC supply cables must be suitable for carrying the maximum supply demand. The voltage drop in the cable should be minimized to ensure the AC supply voltage at the EDP70 PLUS UPS terminals is within +/- 10% of nominal.

The EDP70 PLUS UPS should be connected to the main/reserve supplies and output load via a wall mounted junction box.

Installation and connection should only be carried out by qualified electrical personnel.

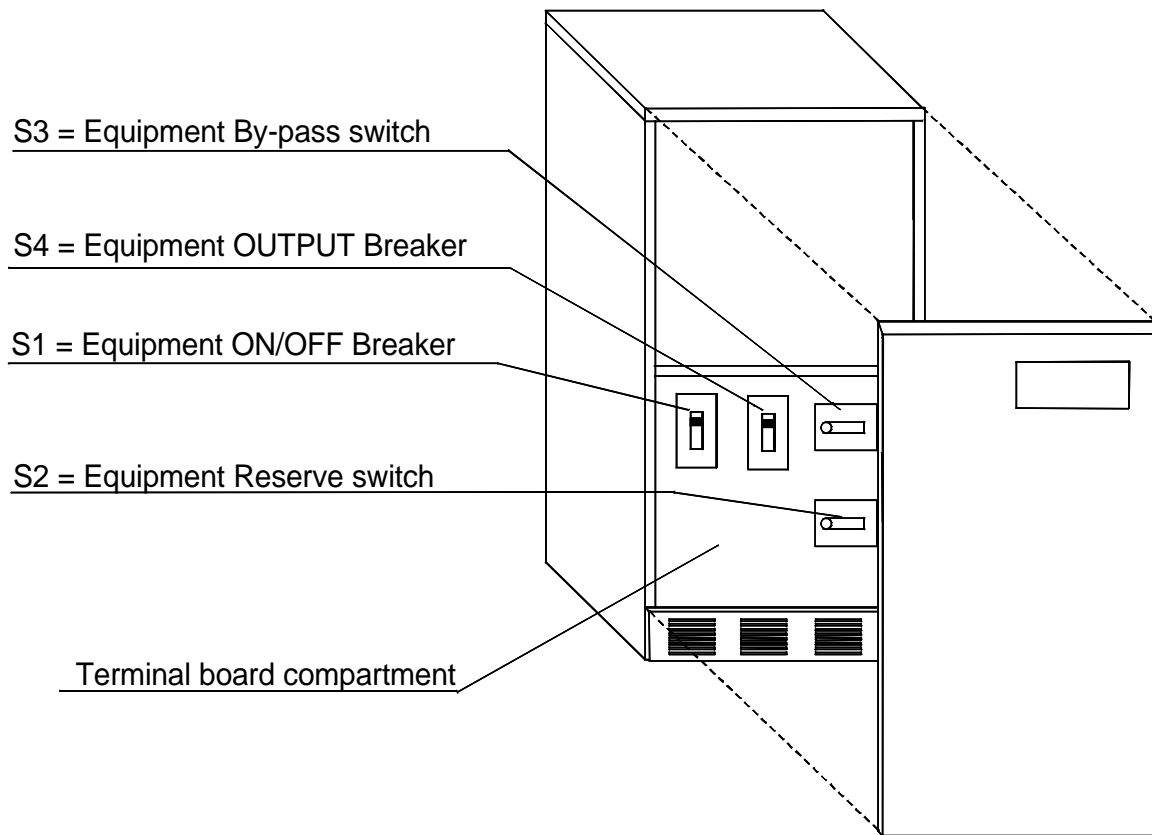

Figure 19 - 36 – 24/30/36kVA: Switches and Breakers

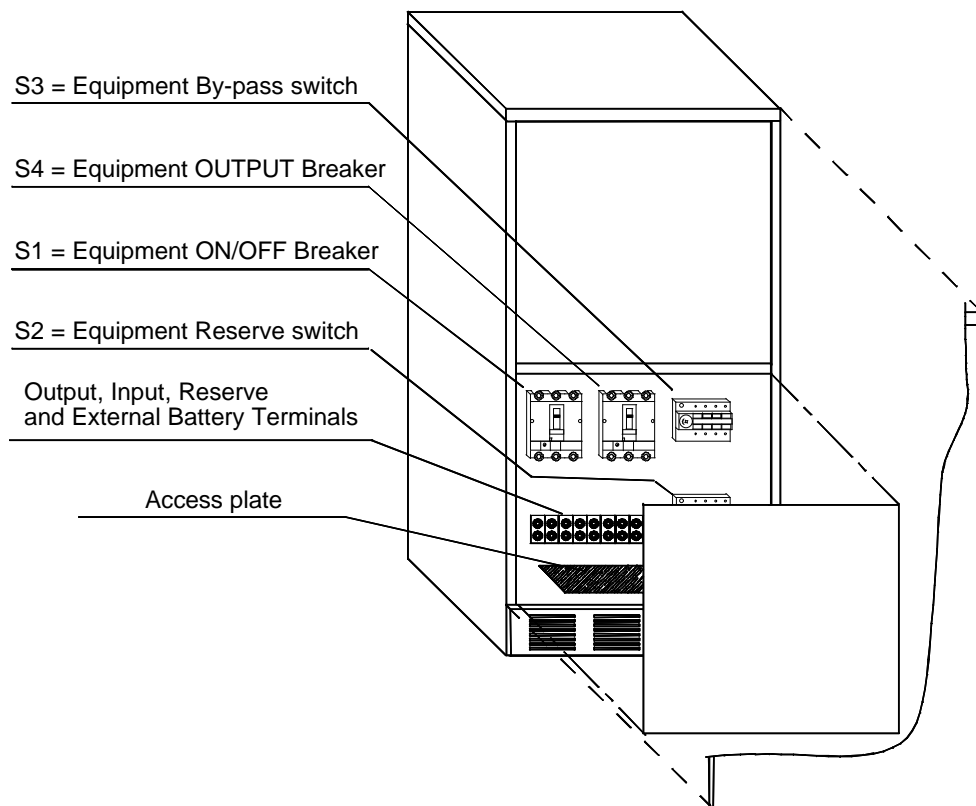

Figure 20 - 36 – 24/30/36kVA: Connections

Access to the terminals for electrical connections is as follows:

- a) Remove front panel see Figure 20.
- b) Remove the terminal board compartment panel by unscrewing the fixing screws at the front.
- c) This exposes the electrical terminal rail, see Figure 21
- d) Remove the screws securing the access plate.
- e) Push the interconnection cables up through the access plate.
- f) Release the terminal securing nuts by unscrewing fully anti-clockwise. All cables must be terminated with the correct size lugs and connected on the bottom side terminals as marked.
- g) Install or start-up batteries see section 13.3 and 13.4.
- h) Replace and tighten the terminal securing screws fully clockwise and refit the access plate.
- i) Replace the terminal board compartment panel and the front cover.

OBSERVE POLARITIES AND ORIENTATIONS.

See Remote Alarms and Computer Interface for connections to these facilities.

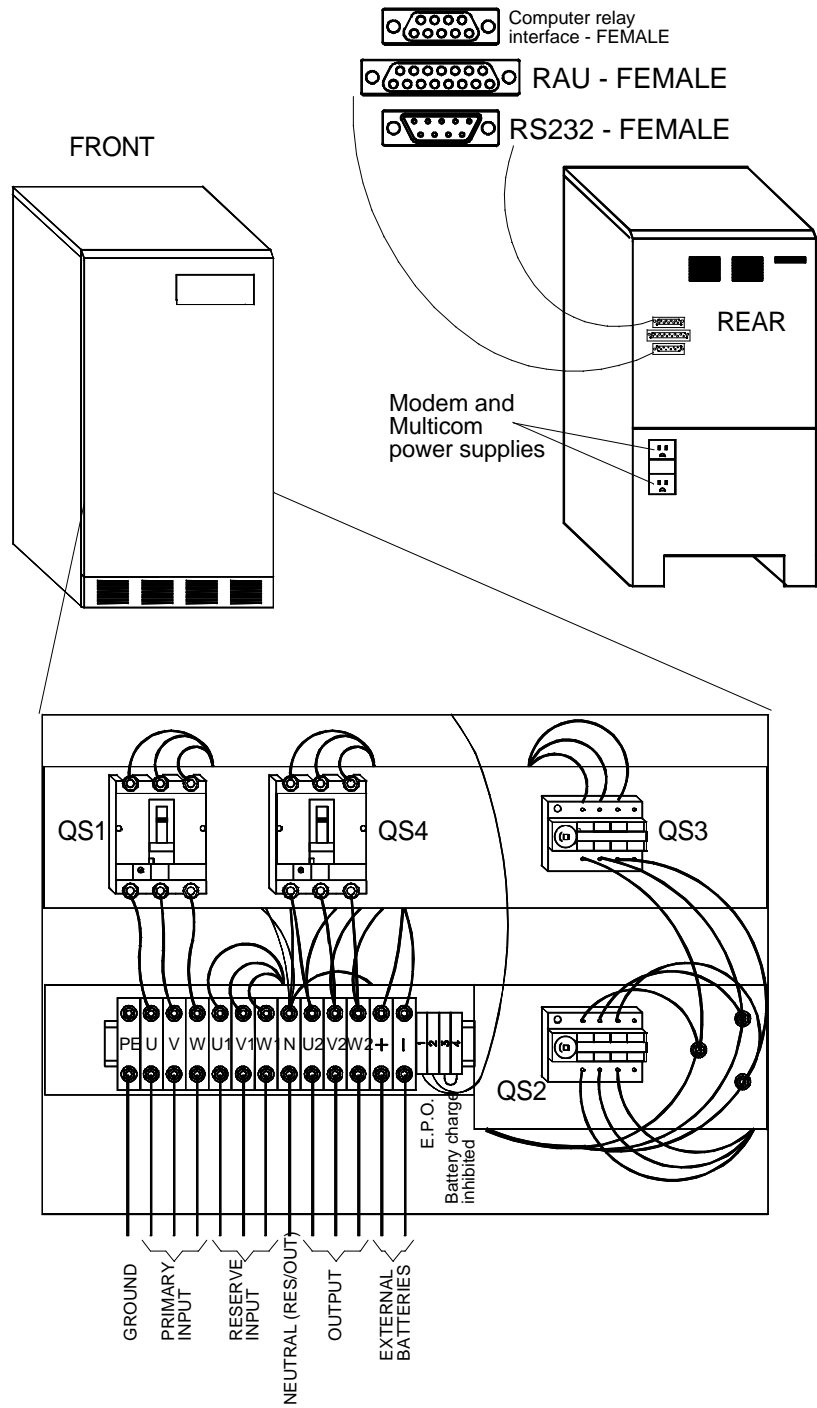

Figure 21 - 36 – 24/30/36kVA: Cable Connections

5.3 EDP70 PLUS 50/80kVA

Ensure the AC supplies and load are switched OFF. Check that **all the EDP70 PLUS UPS Switches** (behind the front panel) are switched OFF, see figure 16.

The AC supply cables must be suitable for carrying the maximum supply demand. The voltage drop in the cable should be minimized to ensure the AC supply voltage at the EDP70 PLUS UPS terminals is within +/- 10% of nominal.

The EDP70 PLUS UPS should be connected to the main/reserve supplies and output load via a wall mounted junction box.

Installation and connection should only be carried out by qualified electrical personnel.

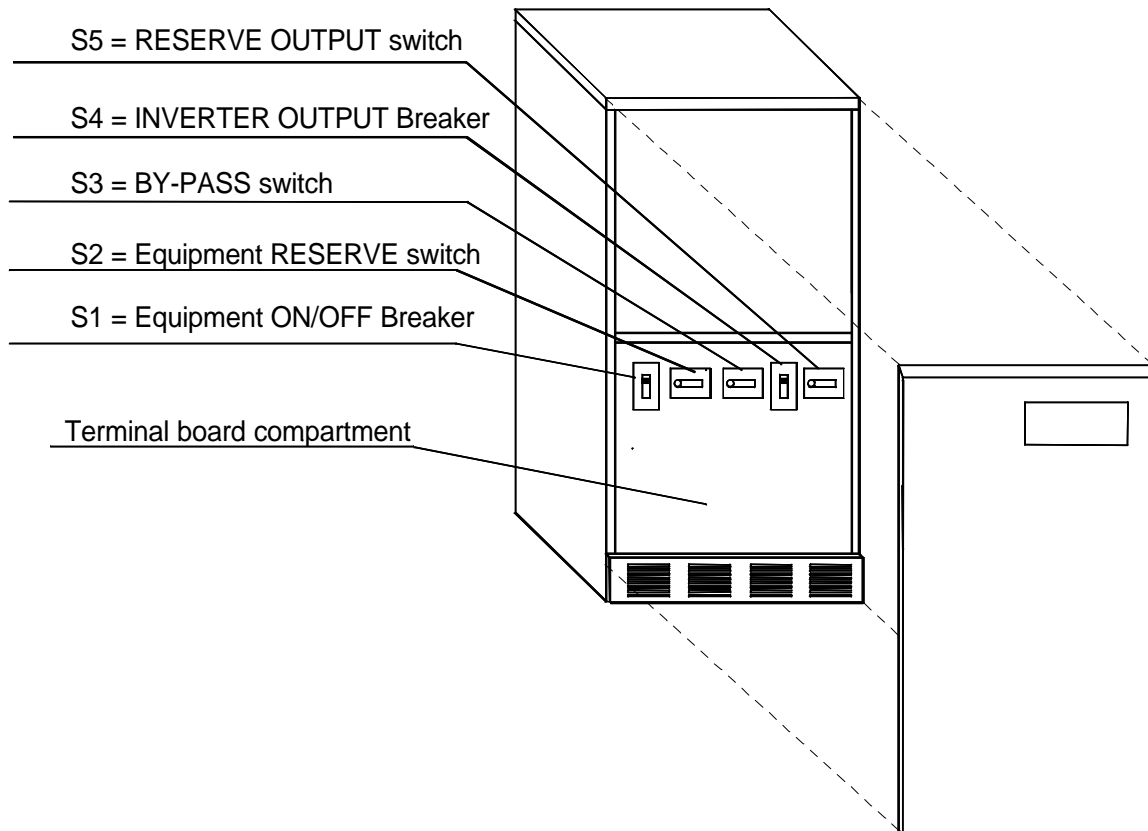

Figure 22 – 50/80kVA: Switches and Breakers

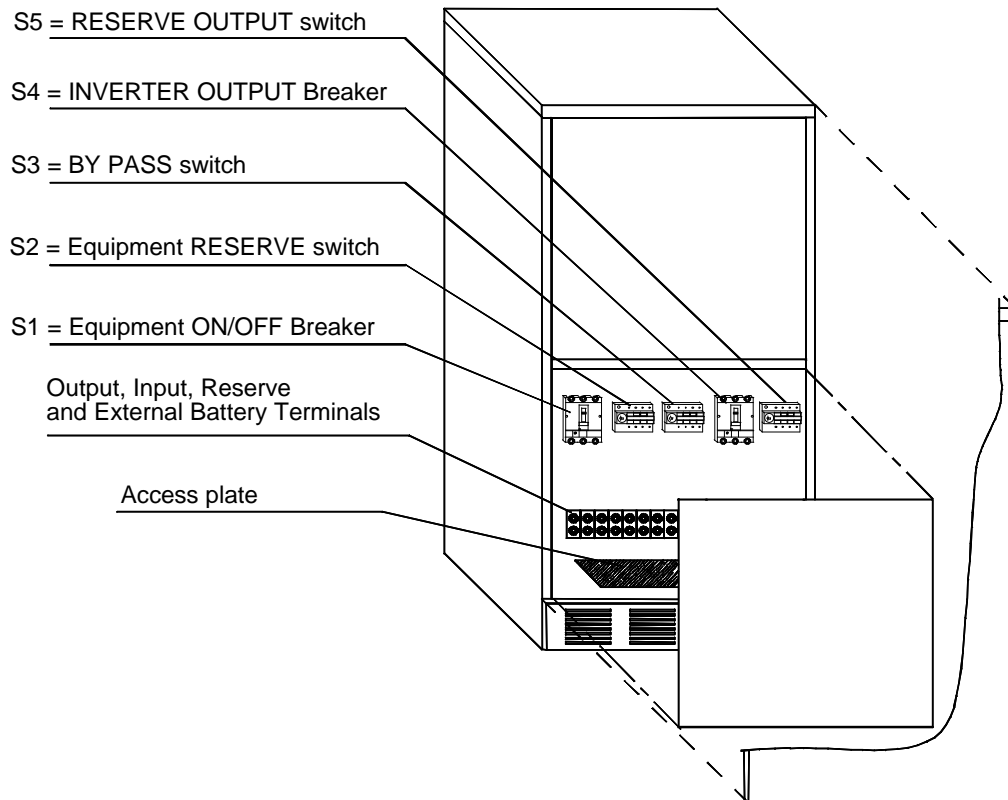

Figure 23 – 50/80kVA: Connections

Access to the terminals for electrical connections is as follows:

- a) Remove front panel see Figure 20.
- b) Remove the terminal board compartment panel by unscrewing the fixing screws at the front.
- e) This exposes the electrical terminal rail, see Figure 21
- f) Remove the screws securing the access plate.
- e) Push the interconnection cables up through the access plate.
- f) Release the terminal securing nuts by unscrewing fully anti-clockwise. All cables must be terminated with the correct size lugs and connected on the bottom side terminals as marked.
- g) Install or start-up batteries see section 13.3 and 13.4.
- h) Replace and tighten the terminal securing screws fully clockwise and refit the access plate.
- i) Replace the terminal board compartment panel and the front cover.

OBSERVE POLARITIES AND ORIENTATIONS.

See Remote Alarms and Computer Interface for connections to these facilities.

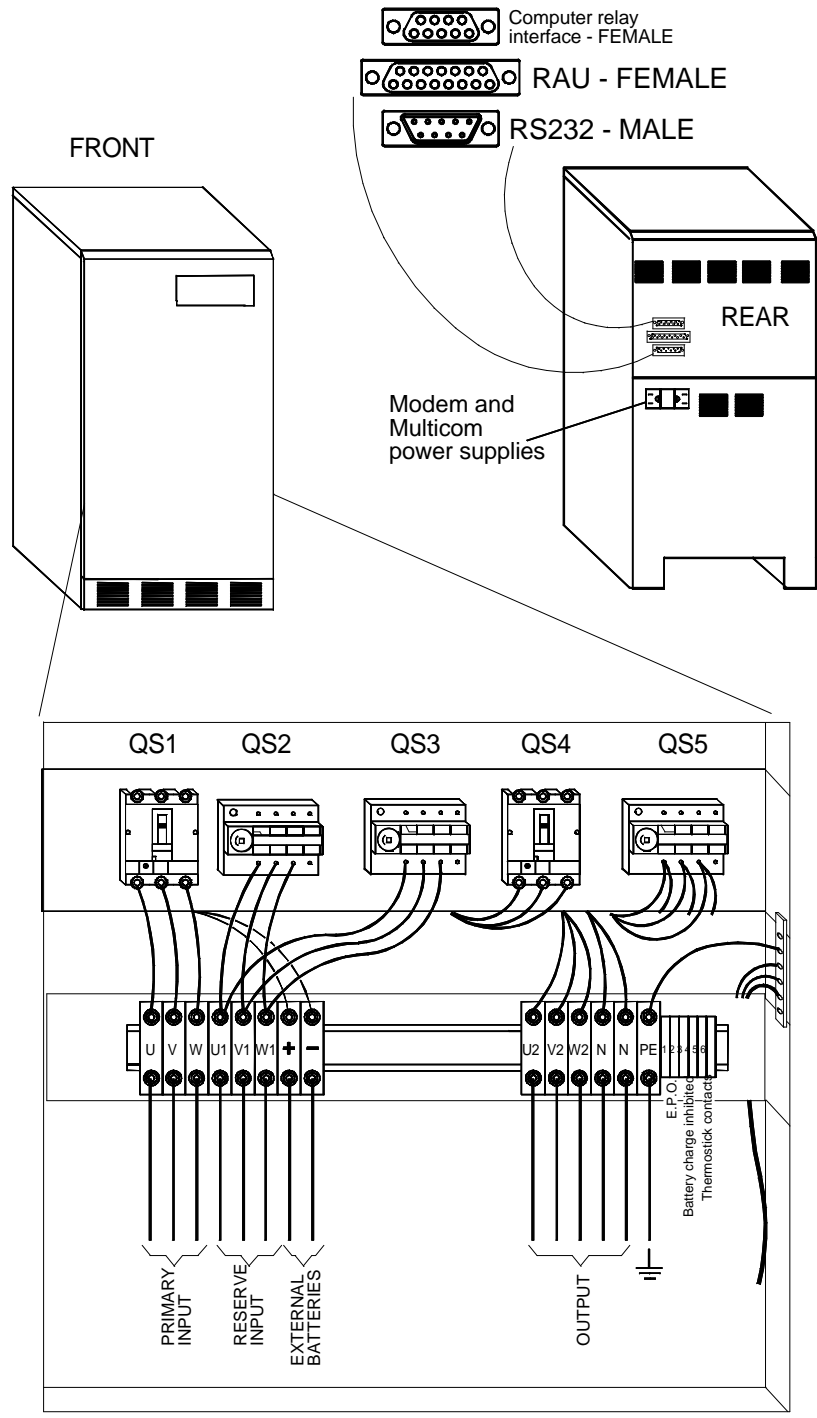

Figure 24 – 50/80kVA: Cable Connections

5.4 *Signal connections*

a) **Emergency Power Off**

When the connection between terminals 1 and 2 is opened, the UPS will stop, and it will automatically restart when the switch is closed. This allows a remote E.P.O. to be installed, in series with the standard one installed inside the UPS. (See Para. 9.1)

Warning: To avoid unauthorized stopping, it is strongly recommended that some form of security switch be used..

b) **Battery charge inhibited**

By removing the link between terminals 3 and 4, the battery charge will be inhibited, and a warning message will be displayed.

Possible uses of this could be one, or more, of the following:

- connect the above terminals to a contact which will be opened if there is Hydrogen within the battery compartment(s).

In this way the cause of hydrogen generation will be stopped, and a warning about the operating status of the system will be displayed.

- connect the above terminals to a contact which will be opened when the UPS is supplied by a Generator (it should be an auxiliary contact of the Line <-> Generator changeover).

In this way it will be possible to limit the power supplied by the Generator to the only value required to supply the critical loads, and not to charge the battery until the mains supply returns.

In this way it is possible to use a Generator having a power rating less than the maximum input power of the UPS.

Also in this case a warning about the operating status of the system will be displayed.

c) **Thermostick connector (50/80kVA only)**

This connection provides the customer with remote control over the output transformer Overtemperature Alarm ($T_{CORE} = 180^{\circ}C$).

NOTE: If more than one of the above applications (or similar) are installed, the contacts **MUST** be connected in series.

6.0 CONTROLS

6.1 User Controls

The user controls are situated on the front panel, see **Figure 25**.

Access to the Equipment Power Switches can be obtained by removing the front cover.

Figure 25 – Control panel

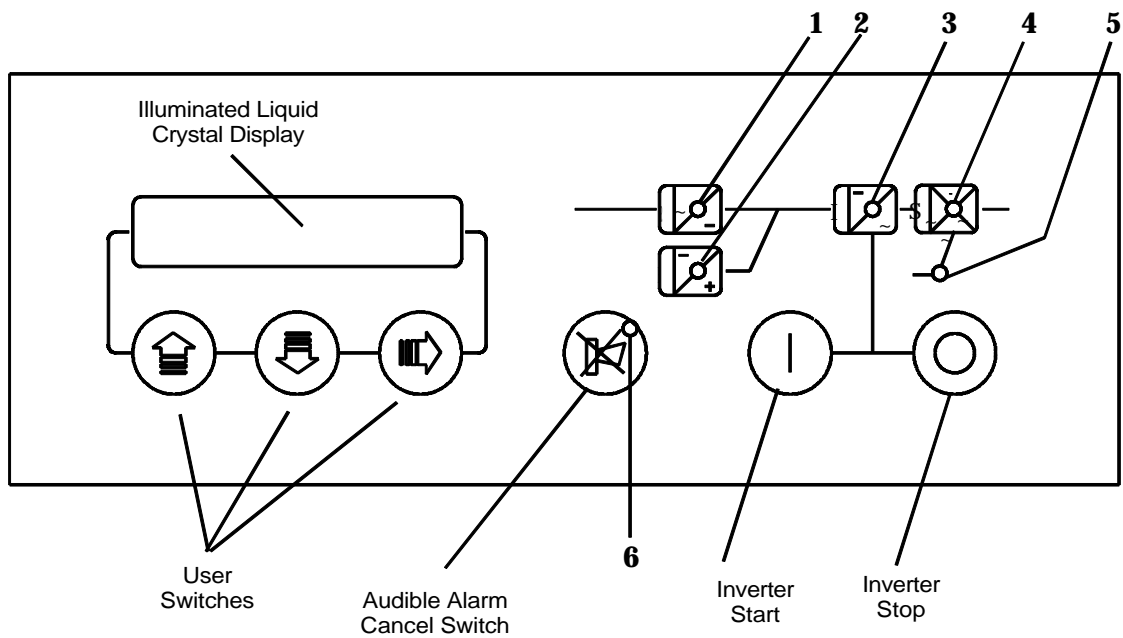

Display indicators

- | | |
|-----------------------------|---------|
| 1) Utility Supply Indicator | (Green) |
| 2) Battery Indicator | (Green) |
| 3) Inverter Indicator | (Green) |
| 4) Static Switch indicator | (Green) |
| 5) Reserve Supply Indicator | (Green) |
| 6) Warning Indicator | (Red) |

6.2 Control Panel

Inverter Start Up

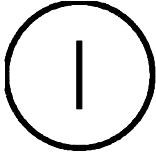

This allows the user to turn on and reset the inverter. This is normally only used when starting the UPS.

Inverter Shutdown

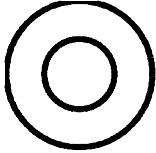

The switch incorporates a safety feature to prevent inadvertent operation yet still allow rapid shutdown in the event of an emergency. This is achieved by the requirement that the switch be depressed for 2 seconds before the inverter stops during which time the audible alarm will be heard.

Audible Alarm Cancel Switch

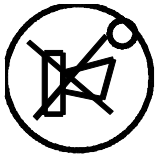

This switch cancels the audible alarm. When pressed the red warning light goes from continuous illumination to flashing on and off.

Page Right Control



This switch changes the page headings displayed on the LCD. It also allows the alarm and measurement statuses to be stepped through when examining the power history (refer to section 10.6)

Record Up



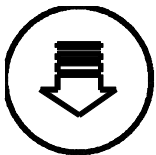

This switch changes the record displayed on the LCD to the previous message displayed. When the top of the page has been reached the display will no longer scroll.

Record Down



This switch changes the record displayed on the LCD to the next record on the page. When the bottom of the page has been reached the display will no longer scroll.

7.0 START UP

1. Switch on the AC reserve and the main AC Utility supply to the UPS.
2. Turn on the Utility supply Input, Reserve Input (if fitted) and UPS Output switches located behind the front panel, see figure 14 for 24kVA, figure 17 for 36kVA or figure 20 for 50/80kVA.
3. Replace the front panel.
4. Press the CANCEL AUDIBLE ALARM switch (see section 6.2)
5. Initially, all the green indicators will flash on the display mimic. After about 30 seconds the supply and battery indicators should stop flashing.
6. Press the Inverter On push button (I).
7. The inverter should now start and after a delay of approximately 30 seconds the message 'SYSTEM NORMAL', in English, will appear on the liquid crystal display.
8. Select the required language by pressing page right control  until the 'SELECT LANGUAGE' message appears on the liquid crystal display. Press the page down control  until the required language is selected. Press the page right control  once more confirm the language selection. Thereafter, all messages will appear in the selected language.

8.0 MAINTENANCE BYPASS

The EDP70 PLUS UPS is equipped with Manual Maintenance Bypass systems. If a unit requires servicing, the Manual Maintenance Bypass allows the load to be connected directly to the AC supply so that the unit may be serviced in safety. The following instructions must be followed:

1. Ensure that 'SYSTEM NORMAL' is displayed on the LCD. (Note: If 'SYSTEM NORMAL' is not displayed check that the inverter is not 'OUT OF SYNC', see section 10.7. Turning the inverter off under this fault condition will interrupt the load supply.)
2. Turn off the inverter by pressing the inverter shutdown button for more than 2 seconds
3. Turn the Maintenance Bypass Switch (located behind front panel, see figure 14, 17 or 20) to ON.
4. Turn off the Primary Input, Reserve Input and UPS Output Switches, see figure 14, 17 or 20.

THE LOAD IS NOW SUPPLIED DIRECTLY FROM THE AC UTILITY SUPPLY AND IS NO LONGER PROTECTED BY THE UPS

CAUTION: Some components in the UPS will retain a static voltage even after the switches have been opened. Also, on the 50/80kVA ratings, the isolating transformer and the relative cooling fans are still supplied from the Bypass.

To return to the normal operating mode, follow the above procedure in reverse.

Note: The EDP70 PLUS UPS must not be left operating with the Maintenance Bypass Switch in the ON position.

9.0 SHUT-DOWN

1. Close down the load in an orderly manner.
2. Push the  (inverter shutdown) button for more than 2 seconds.
3. Turn the main switch to OFF.

Note: If the electricity supply to the site is switched off outside normal working hours, the EDP70 PLUS should be shut down each evening, by either using the shutdown procedure or wiring in the Emergency Power Off (EPO) function, see figures 14, 17, 19 or 22 (depending on the UPS size).

This will prevent the battery from discharging.

If, on the other hand, the supply to the site is continuous, the EDP70 PLUS should be operated 24 hours a day.

9.1 Installing the EPO

To wire the EPO, open the link between terminal boards 1 and 2 and connect a signal switch: when the switch is enabled, the inverter and rectifier will stop, the battery relay will be opened and the load will be de-energized

To ensure that the EPO functions correctly, the signal should remain active for a period > 400 msec.

10.0 VISUAL AND AUDIBLE ALARMS

The EDP70 PLUS UPS is equipped with visual and audible alarms which indicate the status of the UPS to the operator. The visual alarms are displayed on the LCD and the mimic panel.

10.1 Silencing Audible Alarm

The audible alarm sounds when the UPS is in an alarm condition. The sound is silenced by pressing the button

marked  .

When pressed, the red warning light which is illuminated continuously starts to flash, providing an even clearer indication of the alarm condition, even though the audible alarm has been silenced.



10.2 Mimic

The display mimic consists of a pictorial representation of the functional blocks in the EDP70 PLUS UPS. When the system is in NORMAL OPERATING CONDITION the green indicators are illuminated continuously.

In the event of an ALARM condition the indicators start to flash identifying the part (or parts) of the system in alarm (see figure 19).

Further information on the alarms can be obtained from the LCD by scrolling through the page headings using the

 button (page right control) until the message on the display describes the functional block in the UPS identified by the flashing LED(s).

The alarms can then be accessed using the  (scrolling up) and  (scrolling down) record buttons. This procedure is described in detail in section 10.4.

10.3 Liquid Crystal Display

The display is a 40-character (2 line x 20 character) module which is back lit.

The messages describing the functioning of the system are accessed via the user switches (see figure 18).

10.4 Display Page Headings

After initial power up, under normal operating conditions, the main page heading will be displayed:

<p>UPS xx KVA SYSTEM NORMAL</p>

The first line displays the power rating of the EDP70 PLUS UPS, the second line is the system status.

During normal operating conditions, the display reading always returns to this page heading whenever the user switches are not operated for at least 5 minutes.

By pressing the button marked  once, the battery rectifier heading is displayed:

<p>RECT/BATT ALARMS NO ALARMS ACTIVE</p>
--

The second line of the display confirms that the rectifier and battery are functioning correctly.

By pressing the button marked  again, the inverter heading is shown on the display:

<p>INVERTER ALARMS NO ALARMS ACTIVE</p>

The second line of the display confirms that the inverter is functioning correctly.

By pressing the button marked  again, the load output and reserve supply heading is displayed:

<p>LOAD/RES ALARMS NO ALARMS ACTIVE</p>

The second line of the display indicates that the UPS load output and reserve supply input are correct.

By pressing the button marked  again, the selected **battery test period** appears on the display:

**BATTERY TEST
WEEKLY**

The button marked  is pressed to scroll through the 4 battery test period available (WEEKLY, FORTNIGHTLY, MONTHLY and NONE).

The button marked  is pressed to scroll through the list in reverse order.

When the required battery test period appears, press the button marked  to select the battery test period and the selected language heading appears on the display.

**SELECTED LANGUAGE
ENGLISH**

The button marked  is pressed to scroll through the languages available (English, French, German, Italian and Spanish).

The button marked  is pressed to scroll through the list in reverse order.

When the required language appears, press the button marked  to select the language and to return the display to the main UPS status message.

If at any time the inverter is blocked then the power history heading appears:

**POWER HISTORY
DOWN TO ACCESS**

The power history page is described in detail in section 10.6.

The machine measurement signals are accessed from the main page heading as follows:

**UPS xx kVA
SYSTEM NORMAL**



press once

**RECTIFIER
Vdc xxx V Idc xxx A**

Displays the output voltage and current supplied by the rectifier.



press once

**BATTERY
Vb xxx V Ib xxx A**

Displays the battery voltage and the charge or discharge current of the battery (ve = charge, - ve = discharge)



press once

**INVERTER F xx.x Hz
A xxx V B xxx V C xxx V**

Displays the frequency and phase-neutral voltage at which the inverter is running.



press once

**INVERTER F xx.x Hz
AB xxx V BC xxx V CA xxx V**

Displays the frequency and phase-phase voltage at which the inverter is running.



press once

**RESERVE F xx.x Hz
A xxx V B xxx V C xxx V**

Displays the frequency and the phase-neutral voltage of the reserve supply.



press once

RESERVE F xx.x Hz
AB xxx V BC xxx V CA xxx V

Displays the frequency and the phase-phase voltage of the reserve supply.



press once

LOAD F xx.x Hz
A xxx V B xxx V C xxxV

Displays the frequency and phase-neutral voltage supplied to the load.



press once

LOAD F xx.x Hz
AB xxx V BC xxx V CA xxxV

Displays the frequency and phase-phase voltage supplied to the load.



press once

LOAD
A xxx A B xxx A C xxx A

Displays the current supplied to the load.



press once

LOAD
A x% B x% C x%

Displays the load capacity percentage of the UPS rated value.



press once

LOAD P.F. 0.99

P = 80kW s = 80kVA

Displays the Peak Factor of the load current.



press once

TIME ON INVERTER
xxg: xxh: xxm: xxs

Displays the total time the load has been supplied by the inverter since the machine was last switched off.



press once

TIME ON RESERVE
xxg: xxh: xxm: xxs

Displays the total time the load has been supplied by the reserve since the machine was last switched off.



press once

LAST MAINS FAILURE
xxd: xxh: xxm: xxs

Displays the duration time of the most recent Mains Failure



press once

MAINS FAILURE yy
xxgg: xxh: xxm: xxs

Displays the number of mains failures and the total duration of these failures since the machine was last switched off.



press once

TOTAL MAINS FAILURE yy
xxg: xxh: xxm: xxs

Displays the total number of mains failures and their total duration since the machine was installed.



press once

REV A. XX xx-xx-xx
10h00yyy

Displays the code for the version of software resident (and relevant data) within the EDP70 PLUS UPS system

The measurement signals are accessed from the battery rectifier page as follows:

**RECT/BATT ALARMS
NO ALARMS ACTIVE**

Normal operating mode



press once

**RECTIFIER
Vdc xxx V Idc xxx A**

Displays the output voltage and current supplied by the rectifier.



press once

**BATTERY
Vdc xxx V Ib xxxx A**

Displays the battery voltage and the charge or discharge current of the battery (ve = charge, - ve = discharge)

The measurement signals are accessed from the inverter page as follows:

**INVERTER ALARMS
NO ALARMS ACTIVE**

Normal operating mode



press once

**INVERTER F xx.x Hz
A xxx V B xxx V C xxx V**

Displays the frequency and phase-neutral voltage at which the inverter is running.



press once

**INVERTER F xx.x Hz
AB xxx V BC xxx V CA xxx V**

Displays the frequency and phase-phase voltage at which the inverter is running.











press once

**INVERTER
A xxx A B xxx A C xxx A**

Displays the current at which the inverter is running.

The measurement signals are accessed from the load output - reserve supply page as follows:

	LOAD/RES ALARMS NO ALARMS ACTIVE	Normal operating mode
	LOAD f xx.x Hz A xxx V B xxx V C xxx V	Displays the frequency and phase-neutral voltage supplied to the load.
	LOAD f xx.x Hz AB xxx V BC xxx V CA xxx V	Displays the frequency and phase-phase voltage supplied to the load.
	LOAD A xxx A B xxx A C xxx A	Displays the current supplied to the load.
	LOAD A x% B x% C x%	Displays the load capacity percentage of the UPS rated value.
	LOAD P.F. 0.99 P = 80kW s = 80kVA	Displays the Peak Factor of the load current.
	RESERVE F xx.xHz A xxx V B xxx V Cxxx V	Displays the frequency and phase-neutral voltage supplied to the reserve line.
	RESERVE F xx.xHz AB xxx V BC xxx V CA xxx V	Displays the frequency and phase-phase voltage supplied to the reserve line.

10.5 Abnormal operating mode messages

Under abnormal operating conditions, the normal functioning heading on the main page

UPS xx KVA
SYSTEM NORMAL

is replaced with the alarm page:

UPS xx KVA
SYSTEM ALARM

If at least 1 alarm is activated for each block; the »NO ALARMS ACTIVE» message in the second line on the display is replaced with the first active alarm. Whenever there is more than one active alarm, they can be scrolled

through using the  and  keys.

Each message is associated with one of the following conditions:

NORMAL

Conditions which do not adversely affect the normal functioning of the machine are identified under this heading.

No action is required on the part of the operator.

WARNING

Transitory conditions which can either return to normal condition or result in a permanent fault are identified under this heading. No action is required on the part of the operator.

FAULT

Faults are identified under this heading. The intervention of a qualified technician is required.

Alarms which do not come under any of these headings do not require any action if arising separately.

MAIN PAGE HEADING ALARMS

MESSAGE	CONDITION
TESTING BATTERY	NORMAL
EPO ACTIVE	WARNING
NOT CALIBRATED	FAULT
TESTING AUTONOMY	WARNING
SYSTEM TEST MODE	FAULT

a) When the battery is discharging, the machine displays the residual autonomy and the discharging time information.

1. If no information on autonomy is available, then the following message is displayed:

BATTERY DISCHARGING
AUT calc DIS xx min

where xx represents the discharging time

2. Where AUTONOMY information is available, the following message will appear:

BATTERY DISCHARGING
AUT yy min DIS xx min

where yy represents the residual autonomy of the batteries.

b) In overload condition, the machine calculates the time remaining before the inverter is switched off. Under this condition, the following message is displayed:

OVERLOAD
INV STOP xx min: yy:s

If the inverter is inhibited due to overloading, the time at which the inverter will be reactivated is displayed, with the following message:

STOP DUE TO OVERLOAD
RESTART IN xx min: yy: s

RECTIFIER/BATTERY ALARMS

MESSAGE	CONDITION
NOT CALIBRATED	FAULT
DC FEEDBACK FAULT	FAULT
VERIFY DC FEEDBACK	NORMAL
PRIMARY SUPPLY FAULT	WARNING
PHASE SEQUENCE ERROR	FAULT
BATTERY FAULT	FAULT
PCB SUPPLY FAULT	FAULT
BATT CONTACTOR OPEN	-
BATTERY DISCHARGING	WARNING
SHUTDOWN IMMINENT	WARNING
DC VOLTAGE HIGH	FAULT
DC VOLTAGE LOW	WARNING
INPUT SWITCH OPEN	FAULT
HARMONIC FILTER OPEN	FAULT
RECTIFIER ALARM	FAULT
RECTIFIER INHIBITED	WARNING
RECTIFIER BLOCKED	FAULT
BATT. CHARGE INHIBIT	WARNING

INVERTER ALARMS

MESSAGE	CONDITION
NOT CALIBRATED	FAULT
PCB SUPPLY FAULT	FAULT
OUT OF SYNC	WARNING
DESATURATION	FAULT
OVER TEMPERATURE	FAULT
BYPASS SWITCH CLOSED	FAULT
SHUTDOWN IMMINENT	WARNING
DC VOLTAGE HIGH	FAULT
DC VOLTAGE LOW	WARNING
INVERTER NOT RUNNING	FAULT
INVERTER INHIBITED	FAULT
INVERTER BLOCKED	FAULT
INVERTER VOLTS HIGH	FAULT
INVERTER VOLTS LOW	FAULT
OVERLOAD	WARNING
STOP DUE TO OVERLOAD	FAULT
CURRENT LIMIT	WARNING
INV.ST. SWITCH FAULT	FAULT
INV.FREQ.OUT RANG. 8%	FAULT
INV. FEEDBACK FAULT	FAULT
VERIFYING INV. FREQ.	-
VERIFYING BATT. CONT.	-
INV.FREQ.OUT 1%	FAULT

LOAD/RESERVE ALARMS

MESSAGE	CONDITION
NOT CALIBRATED	FAULT
LOAD ON RESERVE	WARNING
LOAD NOT SUPPLIED	FAULT
BYPASS SWITCH CLOSED	FAULT
RESERVE SUPPLY FAULT	WARNING
RESERVE FREQ FAULT	WARNING
RESERVE VOLTS HIGH	WARNING
RESERVE VOLTS LOW	WARNING
ST. SW. BLOCKED ON INV	FAULT
ST. SW. BLOCKED ON RES	FAULT
INV.ST. SWITCH FAULT	FAULT
OVERLOAD	WARNING
OUTPUT SWITCH OPEN	FAULT
RESERVE SWITCH OPEN	FAULT
PHASE SEQUENCE ERROR	FAULT
RESERVE INHIBITED	WARNING
BACKFEED PROT ACTIVE	FAULT

10.6 Power History

The power history is only available when the inverter is blocked; it provides a visual display of the status of the alarms and measurements over a period of 10 seconds before and 1 second after the inverter stops in steps of 0.1 s. The power history is lost when the inverter is restarted.

Figure 20 provides a graphic representation of how to access the Power History.

Fig.20: Power History Structure

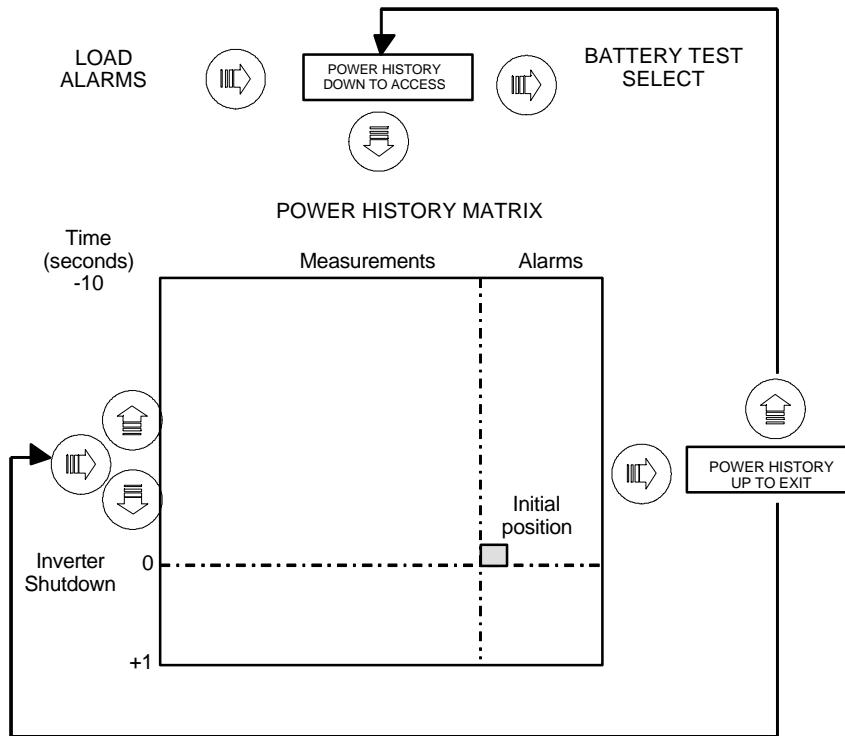

Typical Power History Display

Measurement		Alarm	
RECTIFIER	+0.3 SEC	-5.3 SEC	ON
VDC = 327V	IB = 5A	OVER TEMPERATURE	

10.7 Battery Test

The EDP70 PLUS has an automatic battery control function which checks the condition of the battery periodically without affecting the output in any way. While this test is being carried out, the message »TESTING BATTERY« will appear.

This test can also be activated manually. Return to the main title page so that 'SYSTEM NORMAL' is displayed.



system normal message

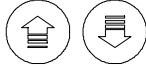

PRESS SIMULTANEOUSLY

(The test is disabled if the **BATTERY TEST** selected is **NONE**)

The battery test is underway and takes approx. 1 minute. If the test is completed without giving off any alarm, then the system returns to normal operating mode; otherwise, the alarm message »BATTERY FAULT« is displayed.

10.8 Battery Autonomy Test

The EDP70 PLUS has a battery autonomy test which disables the rectifier manually.

To carry out this test, return to the main title page so that 'SYSTEM NORMAL' is displayed.



system normal message

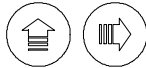

PRESS SIMULTANEOUSLY and keep pressed for 2 seconds

(The test is disabled if the **BATTERY TEST** selected is **NONE**)

The battery starts to discharge completely thereby allowing the autonomy to be checked. Once the battery has been discharged, the test comes to an end automatically and the rectifier restarts.

To interrupt **BATTERY** autonomy Test, at any time: **PRESS SIMULTANEOUSLY**



and



keep pressed for 2 seconds

10.9 Resetting data loss manually

If the message »NOT CALIBRATED« appears on the main title page, this means that data (language and total number of mains failures) which do not directly affect the functioning of the machine have been lost. Despite this,

data has still been lost and the intervention of a qualified technician is required. It is, nevertheless, possible to reset the normal operating mode by selecting the language desired as described under sect. 7.0.

11.0 COMPUTER INTERFACE

11.1 AS400™

The EDP70 PLUS UPS is fitted with a 9 pin female 'D' type socket for direct connection to a IBM AS/400™ computer or equivalent, see figure 21. This facility can also be used with operating system software of other manufacturers. The function of the pins on the socket are shown below:

Pin Number	DESCRIPTION	FUNCTION NUMBER
8	EDP70 PLUS UPS ON	The UPS is supplying the load.
6	RESERVE TO LOAD	The reserve AC supply is supplying the load.
9	UTILITY SUPPLY FAIL	The AC utility supply to the UPS has failed.
7	BATTERY LOW	The battery capacity is at a minimum and the inverter will shortly shut down and the load will be automatically transferred to the reserve AC supply.
5	COMMON	All the above are connected to common when the function is true.

Fig.21: EDP 70 Plus Computer Interface Pin Layout

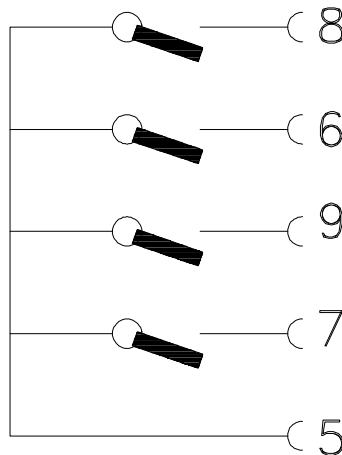

11.2 RS232

The EDP70 PLUS UPS is fitted with a 9 pin male 'D' type plug which enables a communication link to be established between a computer and the microprocessor controller in the EDP70 PLUS UPS. The link allows the Chloride 'EASY PLUS' and 'LIFE 2000' software to be run on an IBM compatible PC. The link also allows the communications with a Master JBUS and Multicom/LIFE 2000 adapter.

The function of the pins on the socket are shown below:

The function of each pin is the following :

Pin 1	DCD	(Data Carrier Detect)
Pin 2	RXD	(Received data)
Pin 3	TXD	(Transmitted data)
Pin 4	DTR	(Data terminal ready)
Pin 5	GND	(Ground)
Pin 6	DSR	(Data Set Ready)
Pin 7	RTS	(Request To Send)
Pin 8	CTS	(Clear To Send)

The signals applied on each pin follows the standard EIA RS232.

12.0 REMOTE ALARMS

Remote indication of the state of the EDP70 PLUS UPS is provided by a 15 pin female 'D' type socket and is designed to be used in conjunction with the Chloride EDP Remote Alarm Unit. The function of the pins on the socket are shown below:

Fig.22: EDP70 PLUS Remote Alarms Pin Layout

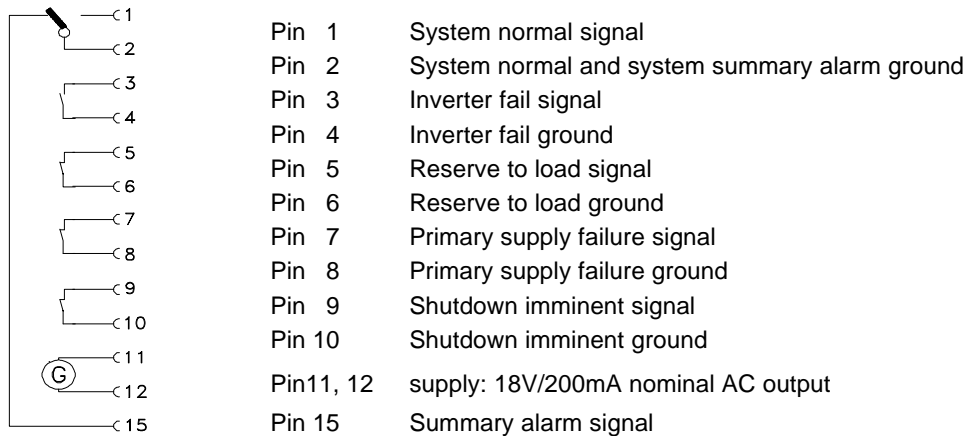

Pins 1,2 and 15 are available for use as a remote summary alarm indicator in alternative to the Chloride Remote Alarm Unit. All pins are volt free contacts which are capable of carrying a current of 0.5 A and switching 30 V.

13.0 BATTERIES

13.1 EDP70 PLUS/24/18/12 : Battery Installation/Start-up

SAFETY

- Ensure all the Switches are turned to OFF before starting to install the batteries. If any Switches are not turned to OFF the equipment and battery may be damaged. It is also essential for safety reasons that the battery connectors be disconnected before removing the fuse F2 (located behind the hinged panel, see figure 23) to interrupt the battery circuit.
 - Stand on a rubber mat and use insulated tools.
 - Remove all personal effects, rings, watches, pens, which might cause a short circuit when working on the battery. Batteries are live at all times and short circuits can melt metals and cause injury, damage or fire.
 - DO NOT smoke or use naked flames, and avoid creating arcs or sparks when working on the equipment; do not wear clothes which may generate static electricity.
 - The sealed lead-acid batteries contain sulphuric acid. If a battery container is broken any acid leaking will cause burns on contact with skin and attack metal, paint and fabrics. Any area contaminated with acid should be thoroughly washed with large volumes of clean water. Rubber gloves should be worn when handling damaged batteries.
- i) Remove front panel see figure 10
 - ii) Remove the battery compartment panel by unscrewing the fixing screws at the front.

DO NOT remove the safety ground connection. Battery connections are provided with the UPS. Each battery is provided with fastenings.

Internal batteries are housed on three shelves at the bottom of the equipment as shown on figure 23.

If the batteries are fitted, starting with the lower shelf first, remove the packaging. Connect the batteries to the UPS using the plug/socket connectors provided.

If batteries are not already assembled on the shelves arrange them as figures 24 (depending on the battery size), strapping the batteries to the tray as shown.

Starting with the lower shelf, fit and connect the batteries. Ensure that the polarities are correct in accordance with the relevant battery layout diagram.

For each shelf make sure that the polarities are correct and the overall battery shelf voltage is at least 108v for the bottom two shelves and 72v for the top shelf.

Replace the fuse F2, then connect the intershelves connectors and all panels in reverse order of removal before operating the equipment.

13.2 EDP70 PLUS/24/18/12 : Optional Battery Cubicle

The battery autonomy can be increased by employing either one or two optional battery cubicles. Both the UPS and battery cubicles are similar in appearance, however, there is no display panel in the battery cubicle.

The battery cubicle has independent fuse located internally. To connect the battery cubicle to the EDP70 PLUS UPS follow the following procedure:

1. Shutdown the UPS using the procedure set out in section 9. Access the terminal rail.
2. Disconnect the battery connectors of the internal battery, then remove the fuse F2 located behind the hinged panel, see figure 23.
3. Be sure that the battery on the cubicle are disconnected. Remove the fuse of the battery cubicle.
4. Wire the cubicle according to the extension battery cubicle wiring instructions and the relevant battery layout diagram.
5. Replace the fuses F2 both on the cubicle and the UPS, then connect all the intershelves connectors, and all the panels and restart UPS using the procedure set out in section 7.

Fig. 23 = EDP70 PLUS/24/18/12: Internal Battery Shelves

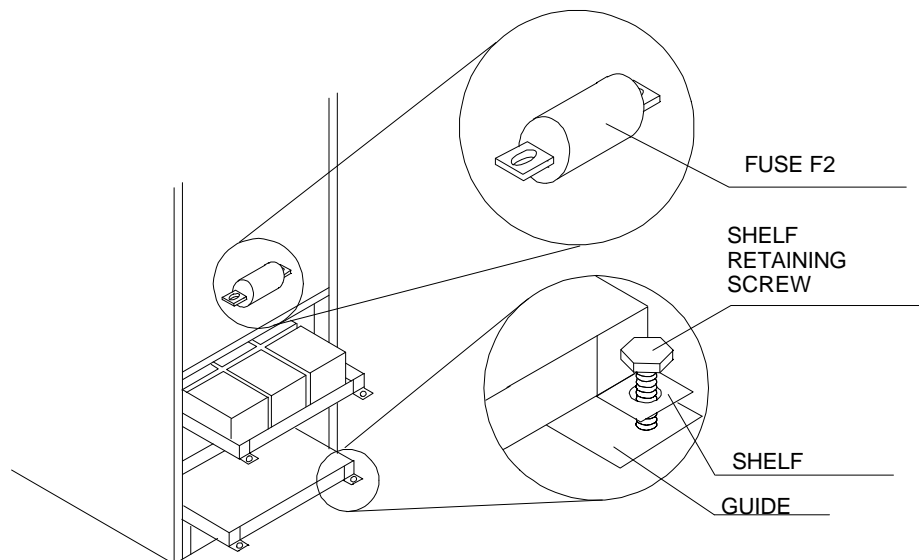

13.3 EDP70 PLUS above 20kVA: Battery Installation/Start-up

SAFETY

- Ensure the Equipment ON/OFF Switch is turned to OFF before starting to install the batteries. If the Equipment ON/OFF Switch is not turned to OFF the equipment and battery may be damaged. It is also essential for safety reasons that the battery connectors are disconnected before to remove the fuse of the battery cubicle.
- Stand on a rubber mat and use insulated tools.
- Remove all personal effects, rings, watches, pens, which might cause a short circuit when working on the battery. Batteries are live at all times and short circuits can melt metals and cause injury, damage or fire.
- DO NOT smoke or use naked flames and avoid creating arcs or sparks when working on the equipment; do not wear clothes which may generate static electricity.
- The sealed lead-acid batteries contain sulphuric acid. If a battery container is broken any acid leaking will cause burns on contact with skin and attack metal, paint and fabrics. Any area contaminated with acid should be thoroughly washed with large volumes of clean water. Rubber gloves should be worn when handling damaged batteries.

13.4 EDP70 PLUS above 20kVA: Battery Cubicle

For these sizes of EDP70 PLUS, the batteries are housed in battery cubicles. Both the UPS and battery cubicles are similar in appearance, however, the battery cubicle does not have a display.

The battery cubicle has a separate fuse, located internally. To connect the battery cubicle to the EDP70 PLUS UPS follow the following procedure:

1. Shutdown the UPS using the procedure set out in section 9. Access the terminal rail.
2. Be sure that all the batteries in the cubicle(s) are disconnected. Remove the fuses from the battery cubicle(s).
4. Wire the cubicle according to the extension battery cubicle wiring instructions and the relevant battery layout diagram.
5. Replace the fuses on all the cubicles then connect all the inter-shelf connectors, and replace all the panels and restart UPS using the procedure described in section 7.

14.0 MAINTENANCE AND SPARE PARTS

The EDP70 PLUS UPS is designed to be virtually user maintenance free, requiring only the occasional wipe with a damp cloth or non-abrasive cleaner.

Spares kits are available for the EDP70 PLUS series, please contact a Chloride Power Electronics service center for details.

EDP70 PLUS SYSTEM LOG

It is recommended that any maintenance action or failure of the SYSTEM be recorded in this log.

Date	Time	Event	Action/Result