

## INSTRUCTION MANUAL

USE UNDER SUPERVISION OF AN ADULT

# RADIO CONTROL

• PLEASE READ CAREFULLY BEFORE STARTING TO OPERATE

# RALLY CAR™



- FULLY DIRECTIONAL
- WHEEL ALIGNMENT
- DIFFERENTIAL GEAR BOX
- HEADLIGHTS & TAILLIGHTS

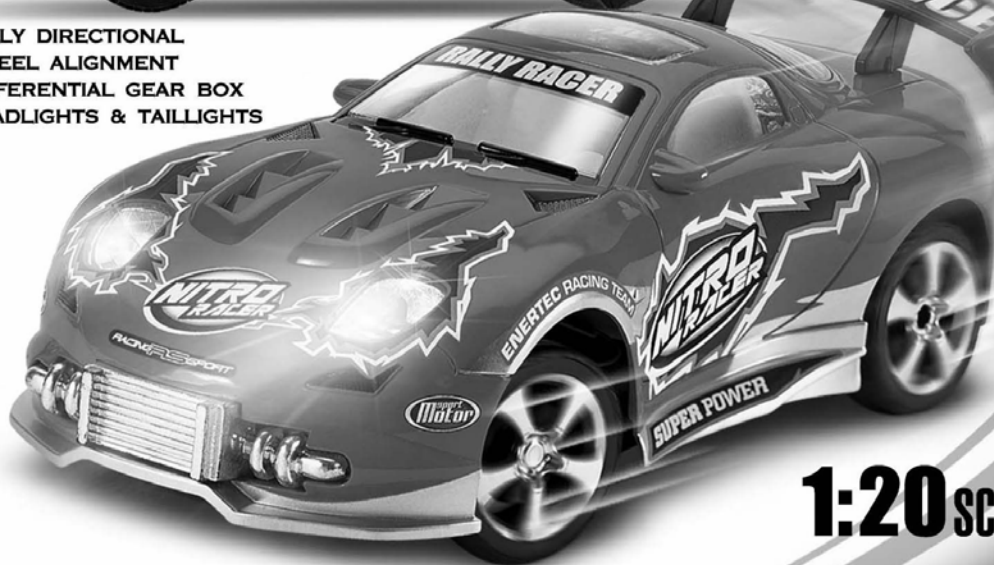

**1:20 SCALE**

### NO. 1216 RALLY CAR (BATTERIES NOT INCLUDED)

#### BATTERIES REQUIREMENTS:

- 4 x "AA" (R6) 1.5V BATTERIES (Not included)
- 2 x "AA" BATTERIES (Not included)

### NO. 1219 RALLY CAR (BATTERIES INCLUDED)

#### BATTERIES REQUIREMENTS:

- 4 x "AA" (R6) 1.5V BATTERIES (Included)
- 2 x "AA" BATTERIES (Included)



#### WARNING:

CHOKING HAZARD--Small parts  
Not for Children under 3 years

## ENERTEC™

ENERTEC ENTERPRISES LTD

(Packing has to be kept since it contains  
important information.)

## BATTERY & ON/OFF SWITCH DIAGRAM AND BATTERY INSTALLATION

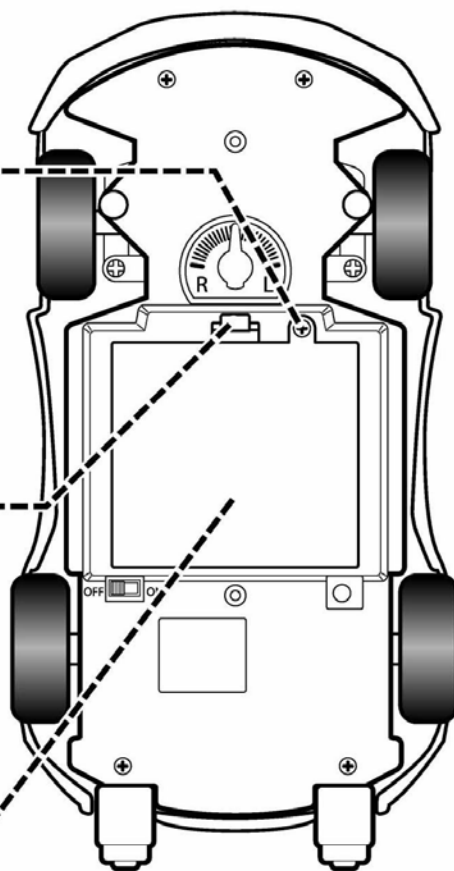
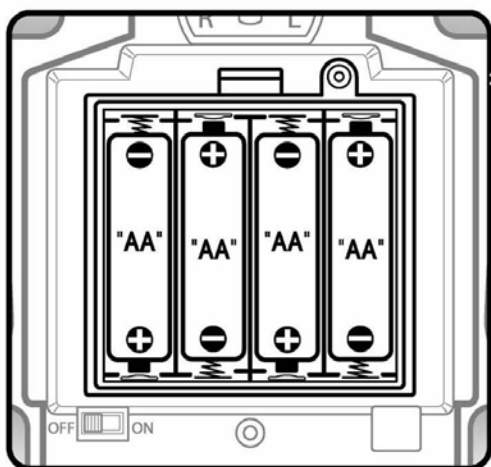
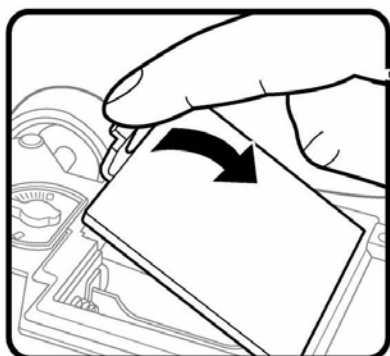
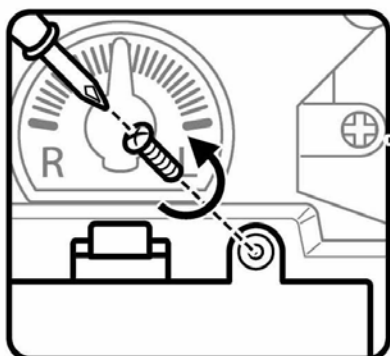

### VEHICLE

- TURN THE KNOB AND OPEN THE BATTERY COMPARTMENT AT THE BOTTOM OF THE CHASSIS WITH A PHILLIPS SCREWDRIVER.
- INSERT 4 PCS. "AA" BATTERIES INTO THE BATTERY COMPARTMENT. MAKE SURE THE ENDS OF THE BATTERIES OF POSITIVE (+) AND NEGATIVE (-) SIGNS MATCH THE MARKINGS ON THE BATTERY COMPARTMENT.
  - CLOSE AND TIGHTEN THE BATTERY COVER USING A PHILLIPS SCREWDRIVER.

### \*IMPORTANT!

MAKE SURE TO TURN THE SWITCH TO THE "OFF" POSITION AFTER USE TO AVOID DRAINAGE OF BATTERIES.

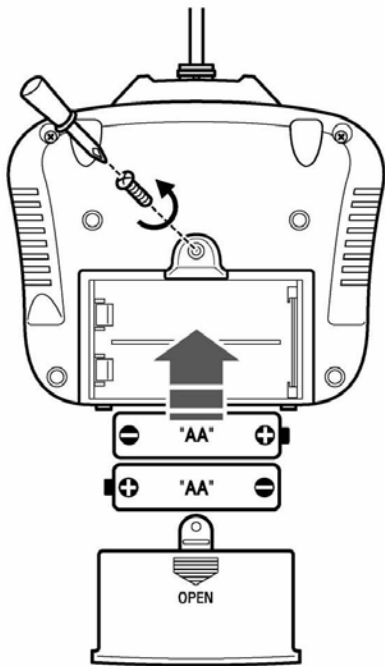

## TRANSMITTER

- UNSCREW THE SCREW AND SLIDE OUT THE BATTERY COVER USING A PHILLIPS SCREWDRIVER.
- INSTALL 2 PCS. "AA" BATTERIES.
- MAKE SURE THE ENDS OF THE BATTERIES OF POSITIVE (+) AND NEGATIVE (-) SIGNS MATCH THE MARKINGS ON THE BATTERY COMPARTMENT.
- SLIDE THE BATTERY COVER BACK IN PLACE AND TIGHTEN THE SCREW USING A PHILLIPS SCREWDRIVER.

### \*IMPORTANT!

MAKE SURE TO TURN THE SWITCH TO THE "OFF" POSITION AFTER USE TO AVOID DRAINAGE OF BATTERY.

## HOW TO OPERATE:

1. Turn **ON/OFF** switches on bottom of car and the transmitter to "ON" position.
2. Extend transmitter antenna to full length when in use.
3. **FORWARD DRIVE:** Push left joystick to position 3 to move forward. Joystick will automatically return to Neutral position when released.
4. **REVERSE DRIVE:** Move left joystick to position 4 to move in reverse. Joystick will automatically return to Neutral position when released.
5. **LEFT/RIGHT STEERING:** Move right joystick left or right to desired direction while operating Forward/Reverse function.



- SCREW THE ANTENNA IN THE CAVITY OF THE TRANSMITTER.

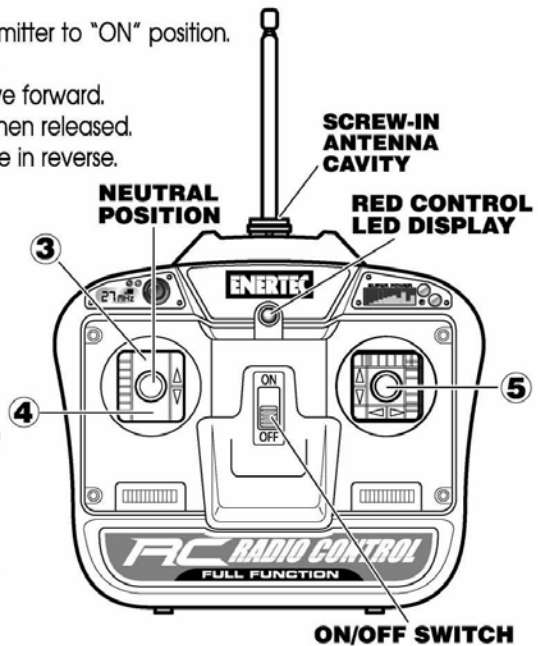

## WHEEL ALIGNMENT



WHEEL ALIGNMENT

SWITCH THE DIRECTION TRIMMER IF THE CAR DOES NOT RUN STRAIGHT, TURN IT TO LEFT OR RIGHT UNTIL YOUR DESIRED ALIGNMENT IS REACHED.

## IMPORTANT NOTICE:

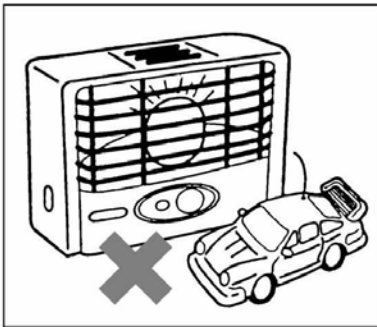
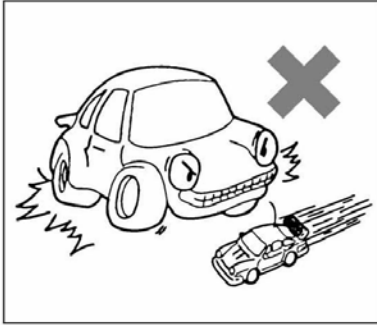

1. Do not mix old and new batteries.
2. Do not mix alkaline, standard (Carbon Zinc) or rechargeable (Nickel-Cadmium) batteries.
3. Do not use RECHARGEABLE batteries.
4. Batteries should be replaced by adults because of small parts.
5. Batteries are to be inserted with correct polarity.
6. Non-rechargeable batteries are not to be charged.
7. Only batteries of the same or equivalent type as recommended are to be used.
8. Exhausted batteries are to be removed from the toy.
9. Don't operate your car in dangerous places.
10. Don't put your car and transmitter near any source of HEAT.
11. Don't run through water, including pools or puddles.
12. Avoid all possible collisions. Check the road ahead and watch for obstacles.
13. Avoid your car and transmitter antennas touching each other.
14. Don't operate your car in the vicinity as another radio-controlled car.
15. Don't leave your car and transmitter outside overnight. Night dampness will cause harm.
16. Don't forget to remove batteries from your car and transmitter if you are not going to operate the car again that day.
17. If malfunction occurs, replace batteries.
18. Adult supervision is required when charging rechargeable batteries.
19. The supply terminals are not to be short-circuited.



FCC Compliant  
FCC ID: OGM12169TX-27

This equipment has been tested and found to comply with the limits for a Class B digital device, pursuant to Part 15 of the FCC Rules. These limits are designed to provide reasonable protection against harmful interference in a residential installation. This equipment generates, uses and can radiate radio frequency energy and, if not installed and used in accordance with the instructions, may cause harmful interference to radio communications. However, there is no guarantee that interference will not occur in a particular installation. If this equipment does cause harmful interference to radio or television reception, which can be determined by turning the equipment off and on, the user is encouraged to try to correct the interference by one or more of the following measures:

- Reorient or relocate the receiving antenna.
- Increase the separation between the equipment and receiver.
- Connect the equipment into an outlet on a circuit different from that to which the receiver is connected.
- Consult the dealer or an experienced radio/TV technician for help.

**MODIFICATIONS NOT AUTHORIZED BY THE MANUFACTURER MAY VOID USERS AUTHORITY TO OPERATE THIS DEVICE**