

IMPORTANT NOTICE:

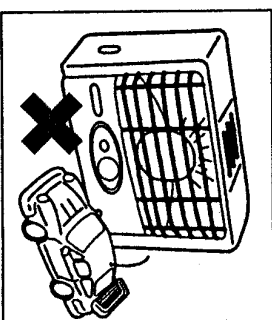
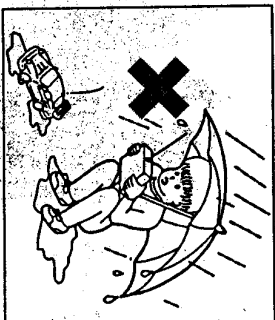
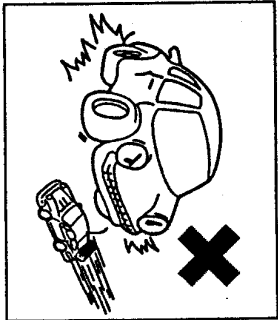

1. Do not mix old and new batteries.
2. Do not mix alkaline, standard (Carbon zinc) or rechargeable (nickel-cadmium) batteries.
3. Do not use rechargeable batteries.
4. Batteries should be replaced by adults because of small parts.
5. Batteries are to be inserted with correct polarity.
6. Non-rechargeable batteries are not to be recharged.
7. Only batteries of the same or equivalent type as recommended are to be used.
8. Exhausted batteries are to be removed from the toy.
9. Don't operate your car in dangerous places.
10. Don't put your car and transmitter near any source of HEAT.
11. Don't run through water, including pools or puddles.
12. Avoid all possible collisions. Check the road ahead and watch for obstacles.
13. Avoid your car and transmitter antennas touching each other.
14. Don't run your car in the same vicinity as another radio-controlled car.
15. Don't leave your car and transmitter outside overnight. Night dampness will cause harm.
16. Don't forget to remove batteries from your transmitter if you are not going to operate the car again that day.
17. If malfunction occurs, replace batteries.
18. The supply terminals are not to be short circuited.

NOTE:

The equipment has been tested and found to comply with limits for a Class B digital device, pursuant to Part 15 of the FCC Rules. These limits are designed to provide reasonable protection against harmful interference in a residential installation. This equipment generates, uses and can radiate radio frequency energy and, if not installed and used in accordance with the instructions, may cause harmful interference to radio communication. However, there is no guarantee that interference will not occur in a particular installation. If this equipment does cause harmful interference to radio or television reception, which can be determined by turning the equipment off and on, the user is encouraged to try to correct the interference by one or more of the following measures:

- Reorient or relocate the receiving antenna.
 - Increase the separation between the equipment and receiver.
 - Connect the equipment into an outlet on a circuit different from that to which the receiver is connected.
 - Consult the dealer or an experienced radio/TV technician for help.
- Modifications not authorized by the manufacturer may void users authority to operate this device



INSTRUCTION MANUAL

USE UNDER SUPERVISION OF AN ADULT

RADIO CONTROL

• PLEASE READ CAREFULLY BEFORE STARTING TO OPERATE

ENERTEC Micro Hauler CHARGER

with HEADLIGHT



NO. 16289
Micro Hauler Charger "Ready to Run"
(ALL BATTERIES ARE INCLUDED)

NO. 1628 Micro Hauler Charger
• CHARGE 5 MINS. CAN PLAY FOR ABOUT 8 MINS.

- Batteries Requirements:
- NI-MH RECHARGEABLE BATTERIES BUILT-IN VEHICLE (not-include)
 - REQUIRES 5 X AA BATTERIES FOR THE CHARGER (not-include)
 - REQUIRES 1 X 9V BATTERY FOR TRANSMITTER (not-include)

WARNING:
CHOKING HAZARD - Small parts
Not for Children under 3 years



0681
(Keep the display box and the instruction manual for future reference.)

BATTERY CHARGER INSTALLATION

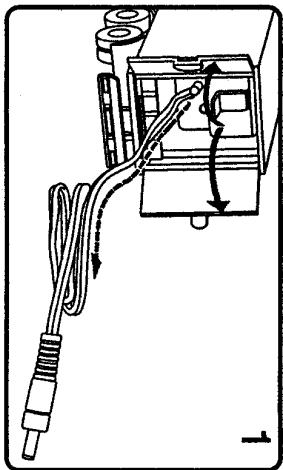

1. Open Trailer Back Door and pull the Cord and Plug out that connects to the battery Charger.

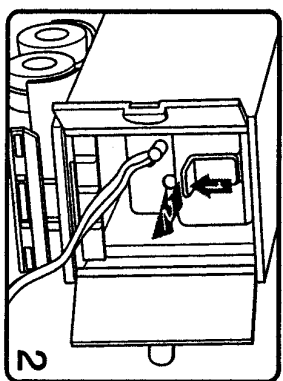

2. Press the Lock Button of the Battery Charger Cassette to release the Cassette and pull it out from the Trailer.

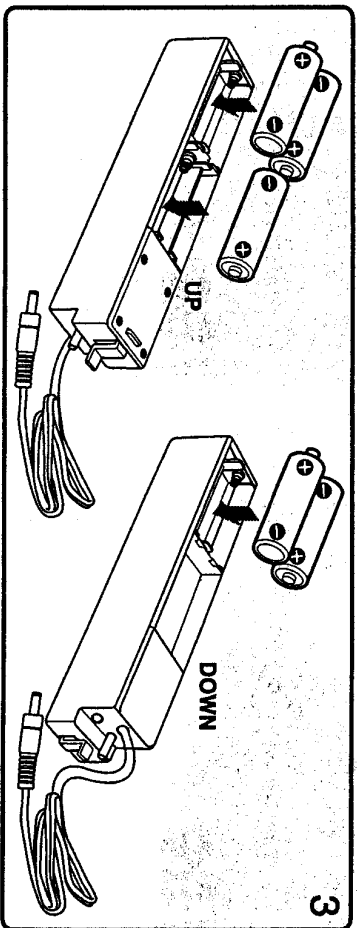

3. Install 5 pcs Batteries in the Cassette as indicated. Follow the Positive (+) and Negative (-) Polarity as indicated on the Cassette.

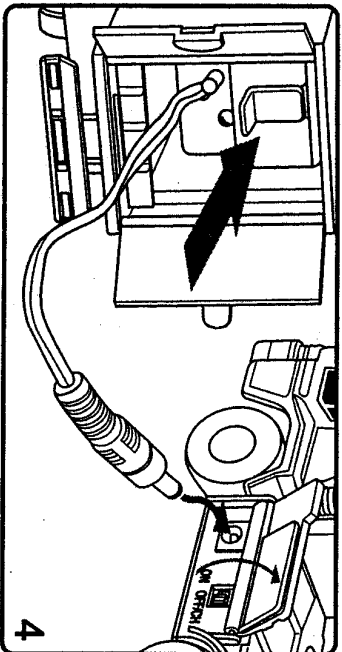

4a. Slide the Battery Charger Cassette back to the Trailer until you hear a 'Click' sound that indicates the Cassette is locked in the Trailer.
4b. Turn the switch on the Cab to 'OFF/CH' mode.
4c. Insert the Plug into the Socket on the Cab.

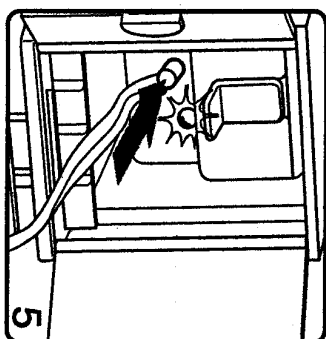

5a. Press the Charger Button on the Battery Charger Cassette then the Charger starts charging the Cab and while it is charging, the Red Lights start blinking. When the Cab is fully charged, the Red Light will go off. (About 5 minutes)
5b. Remove the Plug from the Socket and store it back to the Trailer.
5c. Turn the Switch on the Cab to 'ON' mode then you can start playing.
5d. After playing, turn the switch on the Cab to OFF/CH mode to avoid drainage of battery.

BATTERY INSTALLATION FOR TRANSMITTER

TRANSMITTER BATTERY INSTALLATION:

- Insert 9V battery into the battery compartment.
- Make sure the ends of the batteries positive (+) and negative (-) match the markings on the battery compartment. This is most important.
- Close and tighten the back plate with a Phillips screwdriver and remove battery for storage when not in use.

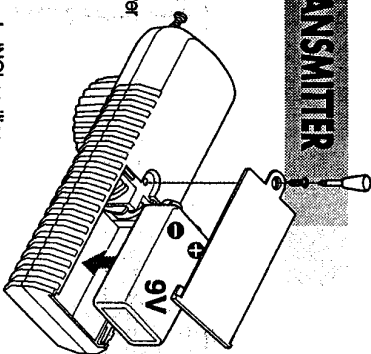

HOW TO OPERATED:

1. Turn ON/OFF switches on left side of cab and transmitter to 'NO' position.
2. Extend transmitter antenna to full length when in use.

3) FORWARD/REVERSE BUTTON

- Push Button up to Forward mode for forward, headlights will light up as vehicle goes forward. Push Button down to Reverse Mode for Reverse direction.
- After playing, turn the switch to OFF mode to avoid drainage of battery.

4) STEERING KNOB

- Turn the Steering Knob to anti-clockwise direction for Turning left and clockwise direction for Turning right. The triangular lights on the top of the knob will light up to indicate the direction.

5) RELEASE BUTTON

- Press the Release Button once to release the Cab from the Trailer, the Cab will detach from the Trailer and move forward at the same time.
- On undusted surfaces, you may press this button once more if the Cab did not release from the Trailer at the first press.
- Change the 9V battery in the Transmitter if it does not function properly.

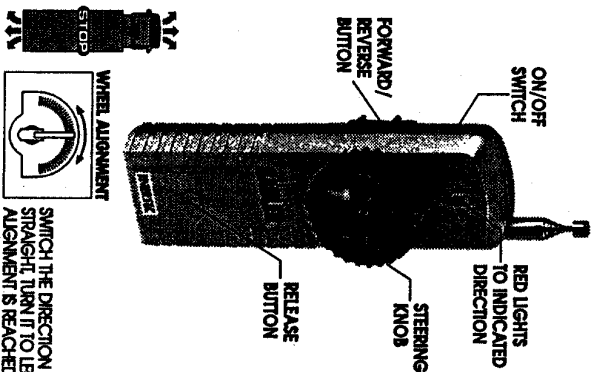

SWITCH THE DIRECTION TRIMMER IF THE CAR DOES NOT RUN STRAIGHT. TURN IT TO LEFT OR RIGHT UNTIL YOUR DESIRED ALIGNMENT IS REACHED.