



# VISTA<sup>®</sup>

## HD WEARABLE CAMERA

### USER GUIDE



# Important Notice

Copyright © 2018 WatchGuard, Inc. All rights reserved. This document and supporting data are the exclusive property of WatchGuard, Inc. and may not be copied and/or reproduced without permission.

## Firmware updates

WatchGuard is committed to the continual testing and improvement of our firmware. As new firmware revisions become available, these updates will be made available to your agency; fees may apply depending on your licensing agreement.

## Contact information

WatchGuard, Inc.

415 East Exchange Parkway

Allen, Texas 75002

Customer Service: 1-800-605-6734

Customer Service web portal: <https://support.watchguardvideo.com/hc/en-us>

## Send us your suggestions

Tell us about your experiences and how you are using the VISTA Body Camera. We will do our best to accommodate suggestions you may have in future revisions.

U.S. customers, call Customer Service or submit a ticket through the Customer Service web portal. International customers, contact your local distributor or submit a ticket through the Customer Service web portal.

## Trademark notice

VELCRO® is a registered trademark of Velcro Industries B. V.

RAM® is a registered trademark of National Products Inc. in the United States and/or other countries.

iPhone® is a trademark of Apple Inc., registered in the U.S. and other countries.

Wi-Fi® is a registered trademark of Wi-Fi Alliance.

Oakley and Flak Jacket® are trademarks or registered trademarks of Oakley, Inc. in the U.S. and other countries.

Littelfuse® is a registered trademark of Littelfuse, Inc. in the United States and other countries.

Sierra Wireless® and AirLink® are registered trademarks of Sierra Wireless.

All other marks, names, and logos are the property of their respective owners.

## FCC and IC notices

This equipment complies with Part 15 of the FCC rules and Industry Canada licence-exempt RSS standard(s). This equipment should only be used with the antenna supplied by WatchGuard Video. Any changes or modifications not expressly approved by the manufacturer could void the user's authority to operate the equipment.

**VISTA WiFi** contains the following IDs:

FCC ID: YJV-VST100

IC: 9073A-VST-100

**VISTA XLT** contains the following IDs:

FCC ID: YJV-VST200

IC: 9073A-VST-200

Cet appareil est conforme à la Partie 15 des règlements de la FCC et Industrie Canada exempts de licence standard RSS. Cet appareil doit être utilisé uniquement avec l'antenne fournie par WatchGuard Video. Tout changement ou modification non expressément approuvée par le fabricant pourrait annuler l'autorité de l'utilisateur de faire fonctionner l'appareil.

**VISTA WiFi** contient les identifiants suivants:

FCC ID: YJV-VST100

IC: 9073A-VST-100

**VISTA XLT** contient les identifiants suivants:

FCC ID: YJV-VST200

IC: 9073A-VST-200

The device complies with Part 15 of the FCC rules and Industry Canada license-exempt RSS standard(s) subject to the following two conditions:

1. The device may not cause harmful interference.
2. The device must accept all interference received, including interference that may cause undesired operation.

Cet appareil est conforme à la Partie 15 des règlements de la FCC et Industrie Canada exempts de licence standard RSS soumis aux deux conditions suivantes:

1. Cet appareil ne peut causer des interférences nuisibles.
2. Cet appareil doit accepter toutes les interférences reçues, y compris les interférences qui peuvent perturber le fonctionnement.

Under Industry Canada regulations, this radio transmitter may only operate using an antenna of a type and maximum (or lesser) gain approved for the transmitter by Industry Canada. To reduce potential radio interference to other users, the antenna type and its gain should be so chosen that the equivalent isotropically radiated power (e.i.r.p.) is not more than that necessary for successful communication.

Conformément à la réglementation d'Industrie Canada, cet émetteur radio ne peut fonctionner à l'aide d'une antenne d'un type et maximum (ou moins) Gain approuvé pour l'émetteur par Industrie Canada. Pour réduire le risque d'interférence avec d'autres utilisateurs, le type d'antenne et son gain doivent être choisis afin que la puissance isotrope rayonnée équivalente (PIRE) ne dépasse pas ce qui est nécessaire pour une communication réussie.

The radio transmitters IC:9073A-VST100 and IC: 9073A-VST-200 have been approved by Industry Canada to operate with the antenna types listed below with the maximum permissible gain and required antenna impedance for each antenna type indicated. Antenna types not included in this list, having a gain greater than the maximum gain indicated for that type, are strictly prohibited for use with this device.

- Antenna type (radio transmitter): WatchGuard Video part number WGP01589-200, 2.2 dbi gain, 50 Ohm impedance

Ces émetteurs radios IC:9073A-VST-100 et IC: 9073A-VST-200 ont été approuvés par "Industry Canada" pour fonctionner avec les types d'antennes énumérés ci-dessous avec le gain maximal admissible et l'impédance d'antenne requise pour chaque type d'antenne indiqué. Les types d'antennes ne figurant pas dans cette liste, ayant un gain supérieur au gain maximum indiqué pour ce type, sont strictement interdits pour une utilisation avec cet appareil.

- Type d'antenne (émetteur radio): WatchGuard Video part number WGP01589-200, 2.2 dBi gain, 50 Ohm impedance

The antennas used for this transmitter must not be co-located or operating in conjunction with any other antenna or transmitter.

Les antennes utilisées pour cet émetteur ne doivent pas être co- Les antennes utilisées pour cet émetteur ne doivent pas être co-localisées ou fonctionner conjointement avec une autre antenne ou un autre émetteur.

This device complies with Health Canada's Safety Code. The installer of this device should ensure that RF radiation is not emitted in excess of the Health Canada's requirement. Information can be obtained at <https://www.canada.ca/en/health-canada/services/environmental-workplace-health/reports-publications/radiation/safety-code-6-health-canada-radiofrequency-exposure-guidelines-environmental-workplace-health-health-canada.html>

Cet appareil est conforme avec Santé Canada Code de sécurité 6. Le programme d'installation de cet appareil doit s'assurer que les rayonnements RF n'est pas émis au-delà de l'exigence de Santé Canada. Les informations peuvent être obtenues:

<https://www.canada.ca/en/health-canada/services/environmental-workplace-health/reports-publications/radiation/safety-code-6-health-canada-radiofrequency-exposure-guidelines-environmental-workplace-health-health-canada.html>

## CE Declaration of Conformity

In accordance with the requirements of Radio Equipment Directive 2014/53/EU, Annex III, Module B, section 3(c), WatchGuard Video declares that the radio equipment has been designed in accordance with harmonized standards and a full review of the equipment against the requirements of the following standards has been conducted. We confirm that the equipment is fully within the scope of these standards.

- ETSI EN 301 489-17, V3.1.1: 2017
- ETSI EN 300 328, V2.1.1: 2016
- EN 55024:2010
- EN 55032:2012/AC:2013
- IEC 60950-1:2005 (Second Edition); Am1:2009 + Am2:2013

# Contents

<b>Introduction</b> .....	<b>11</b>
About this document .....	11
Related documents and information .....	12
What's new for version 3 .....	12
What's new for version 3.0.2: .....	12
What's new for version 3.0.0: .....	12
<b>Using the VISTA Body Camera</b> .....	<b>13</b>
Overview .....	14
Basic workflow .....	14
Wearing VISTA and VISTA WiFi .....	15
Using the rotatable shirt clip and duty belt clip .....	15
Using the locking chest mount .....	16
Using the MOLLE vest loop mount .....	17
Other VISTA and VISTA WiFi mounts .....	18
Wearing VISTA XLT .....	19
Recommended mounting order for VISTA XLT system .....	19
Wearing the DVR .....	20
Using the DVR belt clip .....	20
Using the DVR belt holster .....	20
Wearing the head-mounted camera sensor .....	21
Using the glasses mount .....	21
Preparing your Oakley glasses .....	21
Wearing the body-mounted camera sensor .....	22
Using the magnetic mount .....	22
Using the shirt clip .....	23
Powering On and Off .....	24
Powering on .....	24
Powering off .....	24
Forcing power off .....	25
Starting and Stopping a Recorded Event .....	26

Contents

Starting a recorded event manually ..... 26

Stopping a recorded event manually ..... 27

Muting the Audio During a Recorded Event ..... 28

    Muting audio ..... 28

Categorizing a Recorded Event ..... 29

    Categorizing a recorded event on the camera ..... 29

Docking the VISTA Body Camera ..... 30

    Docking the VISTA Body Camera in a USB Base ..... 31

        Undocking the camera from the USB Base ..... 32

    Docking the VISTA Body Camera in a VISTA Transfer Station ..... 33

    Docking the VISTA Body Camera in a WiFi Base ..... 34

Provisioning the camera ..... 35

    VISTA Body Camera configuration ..... 35

Uploading events ..... 37

    VISTA and VISTA WiFi ..... 38

    VISTA XLT ..... 38

    Record-After-the-Fact® events ..... 39

    Clearing video out of camera storage ..... 39

Upgrading firmware ..... 40

    VISTA and VISTA WiFi ..... 41

    VISTA XLT ..... 41

Charging the battery ..... 42

    VISTA and VISTA WiFi ..... 43

    VISTA XLT ..... 43

VISTA WiFi and VISTA XLT: Associating with a recording group ..... 44

**About the VISTA Body Camera ..... 45**

    Overview ..... 46

    Video, Audio, and Subtitle Evidence ..... 46

        Video ..... 47

        Audio ..... 47

        Subtitles ..... 47

VISTA and VISTA WiFi ..... 48

    Camera sensor and lens ..... 49

    Microphone ..... 49



Buttons ..... 49

    Power button ..... 49

    Record Start/Stop button ..... 50

    Display Backlight button ..... 50

Display ..... 50

VISTA XLT ..... 52

    Camera sensor ..... 52

    Buttons ..... 53

        Power button ..... 53

        Record Start/Stop button ..... 53

        Display Backlight button ..... 54

    Display ..... 54

Information Sequence ..... 56

    VISTA and VISTA WiFi ..... 56

    VISTA XLT ..... 56

Feedback indicators ..... 57

Storage ..... 57

    VISTA and VISTA WiFi ..... 58

    VISTA XLT ..... 58

    Low storage and full storage messages ..... 58

Battery ..... 59

    VISTA and VISTA WiFi ..... 59

    VISTA XLT ..... 60

    LOW BATT/LOW BATTERY message ..... 60

    LOW BASE message ..... 60

    OVERTEMP message ..... 61

Wi-Fi ..... 61

    VISTA WiFi ..... 62

    VISTA XLT ..... 62

GPS ..... 62

    VISTA WiFi ..... 63

    VISTA XLT ..... 63

Quick mounting latch ..... 63

USB Base ..... 64

Contents

Connections ..... 64

    Setting up the VISTA USB Base ..... 64

VISTA Transfer Station ..... 65

    LEDs ..... 65

    Connections ..... 65

    Setting up the VISTA Transfer Station ..... 66

VISTA WiFi Base ..... 66

    LEDs ..... 67

    Connections ..... 68

    Setting up the VISTA WiFi Base ..... 68

**VISTA Body Camera Special Features ..... 69**

    Overview ..... 70

        Recording special features ..... 70

        Battery and storage saving special features ..... 70

        Covert Mode ..... 71

    Pre-Event Capture ..... 71

        Audio ..... 71

    Record-After-the-Fact® ..... 72

        Generating an RATF event ..... 72

        Storage ..... 72

        Audio ..... 73

    Force Microphone On ..... 73

    Sleep Power State ..... 74

        Sleep warning period ..... 74

        Exiting Sleep state ..... 74

    Automatic Off ..... 75

        Automatic off warning period ..... 75

    Maximum Recorded Event Time ..... 76

        Maximum Recorded Event Time warning period ..... 76

    Recording Reminder Alert ..... 77

    Covert Mode ..... 77

**Using VISTA WiFi or VISTA XLT with a Recording Group ..... 79**

    Overview ..... 80

    Recording groups ..... 81





Members of the recording group .....	81
Smart Power Switch .....	82
4RE DVR .....	82
VISTA WiFi Base .....	83
VISTA WiFi and VISTA XLT .....	84
Other devices in the system .....	85
Group recordings .....	85
VISTA WiFi and VISTA XLT behavior during a group recording .....	86
<b>Appendix A: Using VISTA SmartConnect .....</b>	<b>89</b>
SmartConnect Overview .....	90
Activating the VISTA WiFi or VISTA XLT hotspot .....	91
No cameras found .....	92
Controlling battery usage .....	92
Disconnecting SmartConnect .....	93
Standard disconnect .....	93
Nonstandard disconnect .....	93
Connecting to VISTA SmartConnect .....	94
Connecting VISTA WiFi or VISTA XLT to SmartConnect for the first time .....	94
Connecting VISTA WiFi or VISTA XLT to SmartConnect after the first time .....	97
Reviewing VISTA WiFi or VISTA XLT Recorded Events .....	98
Capturing snapshots .....	98
Categorizing Recorded Events .....	99
Live Streaming .....	101
Covert Mode .....	102
Starting and Stopping Recorded Events .....	102
SmartConnect Settings .....	104
Camera Settings .....	104
Camera Data .....	105
<b>Appendix B: Using the Quick Connect Mobile Charger .....</b>	<b>107</b>
FCC Rules compliance .....	107
Overview .....	108
Mobile Charger Parts .....	108
Mobile Charger base .....	109
Mobile Charger cable .....	109

Contents

Cable connection end ..... 110

12 V cigarette-lighter plug ..... 110

Using the Mobile Charger ..... 111

**Appendix C: Upgrading VISTA, VISTA WiFi, and VISTA-Related Devices ..... 113**

Upgrading VISTA or VISTA WiFi to Firmware Version 2.2.0 ..... 114

Upgrading the VISTA WiFi Base and the Smart Power Switch ..... 115

Upgrading VISTA or VISTA WiFi from a Pre-v2.0.2 Firmware Version ..... 116

**Appendix D: VISTA Transfer Station Setup ..... 117**

Overview ..... 118

VISTA Transfer Station Hardware ..... 119

    Setting up the hardware ..... 119

VISTA Transfer Station Configuration ..... 121

    Transfer Station Settings ..... 121

        Static IP ..... 121

        DHCP and Date/Time Settings ..... 122

    VISTA Settings ..... 122

        DHCP ..... 122

        Static IP ..... 123

    Transfer Station administrative functions ..... 123

        Upgrading the Transfer Station software or firmware ..... 123

        Changing the login credentials for the Transfer Station configuration page ..... 124

        Disabling the configuration page ..... 124

        Restarting the Transfer Station ..... 125

    Configuring the Transfer Station ..... 125

**Index ..... 129**



# Introduction

Welcome to the WatchGuard® *VISTA HD Wearable Camera User Guide*. This guide is designed to walk you through the basics of using your VISTA® Body Camera to collect video and audio evidence.

## About this document

The *VISTA HD Wearable Camera User Guide* covers the basic components and operation of VISTA, VISTA WiFi, and VISTA XLT™ including:

- Docking, charging, provisioning, and uploading
- Associating with a recording group (VISTA WiFi and VISTA XLT only)
- Wearing the VISTA Body Camera
- Powering on and off
- Recording evidence
- Categorizing events

This guide includes a section on VISTA Body Camera special features:

- Pre-event and Record-After-the-Fact® (RATF)
- Automatic sleep and power off to help you save battery
- Maximum recording length and periodic recording alerts to help you save storage space
- Covert Mode

This guide also includes a section on recording groups and how VISTA WiFi or VISTA XLT and the WiFi Base work within a local recording group network.

Four appendices to the guide contain:

- Instructions for using the VISTA SmartConnect smartphone app with VISTA WiFi or VISTA XLT
- Instructions for using the VISTA Quick Connect Mobile Charger with extended-capacity VISTA or VISTA WiFi
- Instructions for special upgrades of the VISTA Body Camera and related devices
- Instructions for setting up the VISTA Transfer Station



---

**Note:** *This user guide covers the basic use of the VISTA Body Camera. It is not a comprehensive manual for every possible action or situation you could experience when using the camera. If you have a question about the VISTA Body Camera that is not covered in the user guide, contact your WatchGuard representative.*

---

## Related documents and information

For subjects related to your WatchGuard system that are not covered by the *VISTA HD Wearable Camera User Guide*, see the following documents:

- *4RE® In-Car Video User Guide*
- *Evidence Library 4 Web User Guide*
- *Evidence Library Express User Guide*
- *4RE Vehicle Installation Instructions*

## What's new for version 3

### *What's new for version 3.0.2:*

- **Support for upload from the vehicle using a cellular LTE connection**

Version 3.0.2 gives you the option to upload events from a VISTA Body Camera, docked in the WiFi Base, over a cellular LTE connection to the Evidence Library 4 Web (EL4 Web) upload server.

WatchGuard supports upload over a cellular connection using the Sierra Wireless® AirLink® MG90 High Performance Multi-Network Vehicle Router.

The camera must be configured to upload events to EL4 Web from the WiFi Base.

- Battery metrics improvements
- Performance and security enhancements
- Bug fixes

### *What's new for version 3.0.0:*

- **Support for VISTA XLT (page 52)**

Version 3 gives you the option to use VISTA XLT as part of your fleet of WatchGuard devices. VISTA XLT is a two-piece body-worn camera system with an HD camera sensor separate from the camera DVR. It includes Wi-Fi® and GPS.

- **Support for the VISTA Quick Connect Mobile Charger (page 107)**

Version 3 gives you the option to use the VISTA Quick Connect Mobile Charger with extended - capacity VISTA and VISTA WiFi. The VISTA Quick Connect Mobile Charger is an in-vehicle charging base that uses a cable to connect to a vehicle's 12 V cigarette-lighter receptacle. It can charge a worn VISTA Body Camera while the camera is recording, then be disconnected quickly if needed.



**Important!** *The VISTA Quick Connect Mobile Charger is NOT supported with standard-capacity VISTA or VISTA XLT.*

---

# Using the VISTA Body Camera

*In this section...*

- Basic workflow (**page 14**)
- Wearing VISTA and VISTA WiFi (**page 15**)
- Wearing VISTA XLT (**page 19**)
- Powering the camera on and off (**page 24**)
- Recording evidence (**page 26**)
- Categorizing a recorded event (**page 29**)
- Docking the camera (**page 30**)
  - In the USB base (**page 31**)
  - In the VISTA Transfer Station (**page 33**)
  - In the VISTA WiFi Base (**page 34**)
  - Provisioning (**page 35**)
  - Uploading recorded events from storage (**page 37**)
  - Upgrading firmware (**page 40**)
  - Charging the battery (**page 42**)
  - VISTA WiFi and VISTA XLT: Associating with a recording group (**page 44**)

## Overview

---

You use the VISTA Body Camera as a DVR (digital video recorder) to capture, process, and store video and audio evidence. You connect the camera with your Evidence Library software to provision it as well as to upload its video for evidence management.

WatchGuard offers three types of VISTA Body Camera:

- VISTA: All-in-one HD body camera that does not include Wi-Fi® or GPS
- VISTA WiFi: All-in-one HD body camera that includes Wi-Fi and GPS
- VISTA XLT: Two-piece body camera system with an HD camera sensor separate from the camera DVR; it includes Wi-Fi® and GPS

If your agency is using VISTA WiFi or VISTA XLT, you can pair the camera with a VISTA WiFi Base that is associated with a 4RE DVR. The devices together form a recording group.



**Note:** *If you are not sure whether your equipment has the Wi-Fi feature, contact your WatchGuard representative.*

---

## Basic workflow

The following steps make up a basic workflow for using the VISTA Body Camera during your shift:



**Note:** *This workflow assumes the VISTA Body Camera battery has been fully charged before the camera is checked out to start the shift.*

---

1. With the VISTA Body Camera in the dock, provision the camera and then check it out using your Evidence Library software. (**page 35**)
2. Undock the camera.
3. (VISTA XLT only) Connect the sensor head and cable to the main body of the camera, if not already done. (**page 19**)
4. (VISTA WiFi and VISTA XLT only) Dock the camera in the VISTA WiFi Base (WiFi Base) to pair it with the base and associate it with the local recording group. (**page 44**)
5. (VISTA WiFi and VISTA XLT only) Undock the camera after it has paired with the WiFi Base.
6. Attach VISTA or VISTA WiFi (**page 15**) or VISTA XLT (**page 19**) securely to your clothing.
7. Start and stop recorded events. (**page 26**)
8. Categorize recorded events. (**page 29**)
9. Power the camera off or on, as needed. (**page 24**)
10. Dock the camera to upload recorded events (**page 37**) and charge its battery (**page 42**).

## Wearing VISTA and VISTA WiFi

VISTA and VISTA WiFi have four main mounting options. The quick mounting latch on VISTA and VISTA WiFi attaches to any of the mounts:

- Rotatable shirt clip (below)
- Duty belt clip (below)
- Locking chest mount (**page 16**)
- MOLLE vest loop mount (**page 17**)

Wear VISTA or VISTA WiFi on your clothing where it is most comfortable, convenient, and secure for you. Make sure that the lens is not obstructed and that it is aimed at the horizon.

### Using the rotatable shirt clip and duty belt clip

The rotatable clip mount uses a heavy-duty alligator clip that rotates and slides to make it more convenient for you to secure the camera.



The belt clip mount uses an alligator clip with a hook at the bottom to securely clip the camera to your duty belt.



Both clips connect to the camera the same way:

1. Match the anchor tab on the back of the clip with the slot on the back of the camera.
2. Match the mounting tab on the clip with the quick mounting latch on the camera, then slide the latch over the tab.
3. Attach the clip to your clothing or your belt where you want to wear the camera.

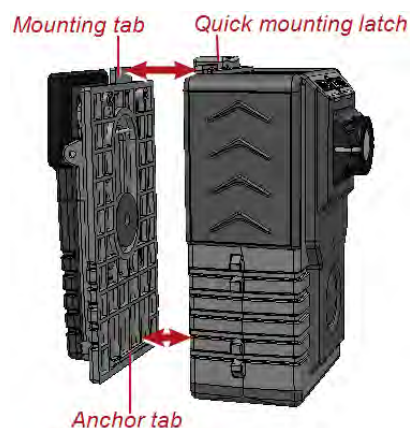

## Using the locking chest mount



**Warning!** The chest mount uses magnets to hold the camera in place. Do not wear the chest mount near sensitive medical equipment or implants such as pacemakers or other magnetically programmable medical devices.



The chest mount uses magnets and locking pins to secure the mount to your clothing. When you wear the chest mount, one bracket goes under your shirt, the other goes over your shirt.



**Important!** Because of the strength of the magnets, separating the brackets requires effort. Realigning the brackets causes them to snap together forcefully.

To use the chest mount:

1. Separate the under-shirt bracket from the over-shirt bracket.
2. Match the anchor tab on the over-shirt bracket with the slot on the back of the camera.
3. Match the mounting tab on the over-shirt bracket with the quick mounting latch on the camera, then slide the latch over the tab.
4. Place the under-shirt bracket under your shirt where you want to wear the camera.
5. Place the over-shirt bracket, with the camera attached, against the under-shirt bracket, with your shirt between them.

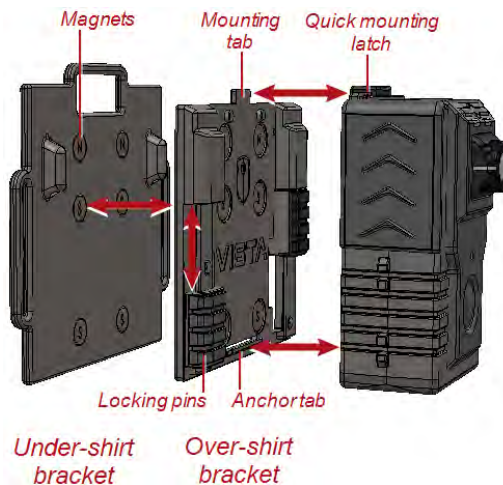

The magnets on both brackets line up automatically, securing the mount to your shirt.

6. To lock the mount in place, slide both of the locking pins up into their safety housings.



**Warning!** The chest mount uses magnets to hold the camera in place. Do not wear the chest mount near sensitive medical equipment or implants such as pacemakers or other magnetically programmable medical devices.



## Using the MOLLE vest loop mount



**Note:** Some of the earliest versions of the VISTA Body Camera do not connect to the MOLLE vest mount. Please consult with your WatchGuard representative for more information.



The MOLLE vest mount uses hooks to anchor VISTA or VISTA WiFi over two rows of loops on the MOLLE vest.



**Tip:** Install the mount on the vest before you connect the camera to the mount.

To use the MOLLE vest mount:

1. Determine which two rows of loops on the MOLLE vest you want to use to mount the VISTA Body Camera.
2. On the lower of the two rows, slide the forked end down over the sewn seam between two loops until the hook is engaged below the seam.

You may need to slightly twist the mount to help the hook slide over the seam.

3. Slightly fold the fabric between the two rows so that the upper loop hooks engage two loops on the upper row of loops.
4. Slide the upper loop hooks down over the two loops, straightening the fabric between the rows, to fully seat the mount.

The forked end should be fully engaged with the seam on the lower row of loops. The hooks should be fully engaged with two loops on the upper row of loops.

5. Match the anchor tab on the bottom of the outward-facing plate of the MOLLE vest mount with the bottom slot on the back of VISTA.
6. Match the mounting tab on the top of the mount with the quick mounting latch on VISTA, then slide the latch over the tab.

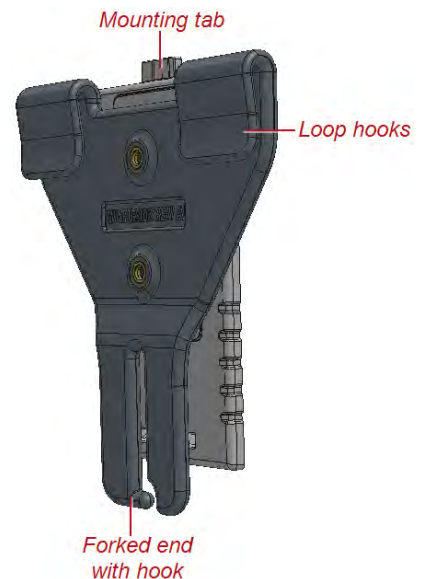

**Note:** The camera connects to the MOLLE vest mount in the same way it connects to the shirt or belt clip. For more information, see *Using the rotatable shirt clip and duty belt clip* on **page 15**.

## Other VISTA and VISTA WiFi mounts

Other mount options include:

- **VELCRO® plate mount:** Works with externally-worn vests with VELCRO surfaces
- **Klick Fast mount:** Works with UK-style Klick Fast receivers
- **Tripod mount:** Works on standard mounts with 1/4"-20 threads
- **RAM® mount:** Includes a 1-inch ball for RAM accessories

Contact your WatchGuard representative for information.

## Wearing VISTA XLT

---

Each VISTA XLT uses two mounts: one for the DVR and one for the camera sensor.

These mounts are available for the DVR:

- Belt clip (**page 20**)
- Belt holster (**page 20**)

This mount is available for the head-mounted camera sensor:

- Glasses mount (**page 21**)

The glasses mount has been designed to work with Oakley Flak Jacket® glasses.

These mounts are available for the body-mounted camera sensor:

- Magnetic mount (**page 22**)
- Shirt clip (**page 23**)

The DVR connects to the camera sensor using a cable. Various cables and strain-relief clips are available.

## Recommended mounting order for VISTA XLT system

To wear VISTA XLT:

1. Disconnect the cable from the VISTA XLT DVR and camera sensor.
2. Mount the DVR and attach it to your belt.
3. Mount the camera sensor and attach it to your glasses or clothing as appropriate.
4. Connect the camera sensor end of the cable to the camera sensor, then route the cable through your clothing toward the DVR as appropriate.



**Note:** The DVR end of the cable is marked with **DVR**.

---

5. Connect the **DVR** end of the cable to the DVR.

Wear the VISTA XLT DVR and camera sensor where they are most comfortable, convenient, and secure for you. Make sure that the lens is not obstructed and that it is aimed at the horizon.



**Tip:** For specific recommendations on wearing VISTA XLT, review the WatchGuard Online Training Course for VISTA XLT. For access to the training course, contact WatchGuard Customer Service.

---

## Wearing the DVR

These mounts are available for the DVR:

- Belt clip
- Belt holster

### Using the DVR belt clip



**Tip:** Remove VISTA XLT from the belt clip before docking the camera.

To use the belt clip:

1. Match the anchor tab on the back of the clip with the slot on the back of the VISTA XLT DVR.
2. Match the mounting tab on the clip with the quick mounting latch on the DVR, then slide the latch over the tab.
3. Attach the clip to your duty belt where you want to wear the DVR.

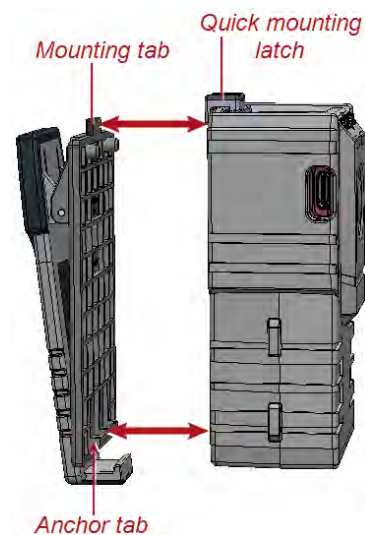

### Using the DVR belt holster

To use the holster:

1. Unsnap the empty holster.
2. Slide the VISTA XLT DVR into the holster with the **Record Start/Stop** button facing out.
3. Snap the holster closed, stretching the elastic over the top of the DVR.
4. Thread the holster onto your duty belt where you want to wear the DVR.



## Wearing the head-mounted camera sensor

The glasses mount is available for the head-mounted camera sensor.



The glasses mount has been designed to work with Oakley Flak Jacket® glasses, available through WatchGuard.

### Using the glasses mount

To use the glasses mount for the head-mounted camera sensor:

1. If you have not already done so, disconnect the cable from your VISTA XLT DVR and camera sensor.
2. On the Oakley glasses provided by WatchGuard, remove the rubber sleeve from the right arm of the frames.

For instructions, see *Preparing your Oakley glasses* below.

3. Snap the glasses mount into the groove on the head-mounted camera sensor.
4. Slide the quick mounting latch backwards and open the hinged part of the mount.
5. Fit the mount over the raised ovals on the bare arm of the Oakley glasses.
6. Close the hinged part of the mount then slide the quick mounting latch forward.



### Preparing your Oakley glasses



**Note:** Oakley glasses are designed for the arms to be removed and the rubber sleeves to be replaced.

To prepare your Oakley glasses for mounting:

1. Grasp the right arm of the glasses near the frame and, with gentle force, twist the arm to snap it out of the frame.
2. Slide the rubber sleeve off of the arm and set it aside.
3. Snap the arm back into the glasses frame.

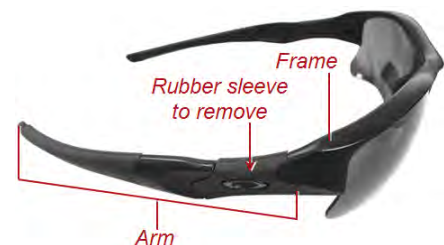

## Wearing the body-mounted camera sensor

These mounts are available for the body-mounted camera sensor:

- Magnetic mount
- Shirt clip



### Using the magnetic mount



**Warning!** The magnetic mount uses magnets to hold the body-mounted camera sensor in place. Do not wear the mount near sensitive medical equipment or implants such as pacemakers or other magnetically programmable medical devices.

To use the magnetic mount for the body-mounted camera sensor:

1. If you have not already done so, disconnect the cable from your VISTA XLT DVR and camera sensor.
2. Separate the under-shirt bracket from the over-shirt bracket.

Separating the brackets requires some effort.

3. On the over-shirt bracket, slide out both latches.
4. Snap the body-mounted camera sensor into the over-shirt bracket, then push in the sliding latches.
5. Place the under-shirt bracket under your shirt where you want to wear the camera sensor.
6. Place the over-shirt bracket, with the camera sensor attached, against the under-shirt bracket, with your shirt between them, making sure the camera sensor LED is at the top.



### *Using the shirt clip*

To use the shirt clip for the body-mounted camera sensor:

1. If you have not already done so, disconnect the cable from your VISTA XLT DVR and camera sensor.
2. Slide out the latch on the clip.
3. Snap the body-mounted camera sensor into the clip (in any orientation), then slide in the latch.
4. Attach the shirt clip to your clothing where you want to wear the camera sensor, making sure the camera sensor LED is at the top.



## Powering On and Off

---

You use the **Power** button to power the VISTA Body Camera on and off. The **Power** button is on the bottom of VISTA, VISTA WiFi, and the VISTA XLT DVR.



### Powering on

To power the camera on:

- With the power off, press and release the **Power** button.

The camera goes through its booting and information sequences. When it is ready to use, the display shows the number of events in storage and the green LED lights steadily. Ascending tones sound (depending on your notification selections).



**Tip:** (VISTA XLT) Press the **Display Backlight** button to advance through the information sequence screens.

---

(VISTA XLT) If the camera sensor is not connected to the DVR, the display reads **Camera UNPLUGGED**. When you connect the camera sensor to the DVR, the display reads **CONNECTING**, then shows the number of events in storage and the green LEDs light steadily.

### Powering off

---



**Note:** The VISTA Body Camera can be configured to power off automatically if it is left idle (no movement and/or button presses) for a period of time. For more information, see **Automatic Off** on [page 75](#).

---

To power the camera off:

- With the power on, press and release the **Power** button two times within 5 seconds.

After you press and release the **Power** button the first time, the display reads **OFF? 2X** (VISTA and VISTA WiFi) or **OFF? Press Again** (VISTA XLT) to confirm that you want to power the camera off.

Once you press the **Power** button the second time, the display reads **SHUTTING DOWN** and the green LED turns off. Descending tones sound (depending on your notification selections).



**Important!** If you do not press the **Power** button a second time within 5 seconds, the display clears, and you need to start the power off sequence again.

---



## Forcing power off

In the rare case where the VISTA Body Camera stops responding to commands (or if WatchGuard Technical Services instructs you to), you can force the camera to power off.



**Warning!** Avoid forcing the VISTA Body Camera to power off, if at all possible. Forcing the camera's power off can, in rare cases, result in data corruption.

---

To force the VISTA Body Camera to power off:

- Press and hold the **Power** button until the camera powers off, about 15 seconds.



**Note:** If you have forced the camera's power off, WatchGuard recommends that you dock it in a USB Base as soon as it is feasible. Docking the camera in a USB Base allows VISTA to repair itself.

---

## Starting and Stopping a Recorded Event

Typically, you use a **Record Start/Stop** button to start or stop a recorded event on the VISTA Body Camera. The **Record Start/Stop** button is on the front of VISTA and VISTA WiFi. VISTA XLT has two **Record Start/Stop** buttons, one on the front of the DVR and one on each camera sensor.

**If your VISTA WiFi or VISTA XLT is a member of a recording group**, the camera can start or stop a recorded event automatically when alerted by another group member that the other group member has started or stopped an event. For more information on recording groups, see *Using VISTA WiFi or VISTA XLT with a Recording Group* on **page 79**.

**If your VISTA WiFi is connected to the VISTA SmartConnect smartphone app**, you can start or stop a recorded event using SmartConnect. For more information on using the smartphone app, see *Starting and Stopping Recorded Events* on **page 102**.



*VISTA XLT head-mounted camera sensor*

### Starting a recorded event manually

To manually start a recorded event on the VISTA Body Camera:

- Press a **Record Start/Stop** button.

(VISTA/VISTA WiFi) The display shows the **REC** icon and the recording length, then begins to blink the **REC** icon. The red LED lights steadily and ascending tones sound with a vibration (depending on your alert notification selections).

(VISTA XLT) The display reads **RECORDING**, then begins to blink the dot in the **REC** icon and show the recording length. The red LEDs light steadily and ascending tones sound with a vibration (depending on your alert notification selections).

As the recorded event continues, the display shows the current recorded event length increasing every second and the storage indicators updating as needed.

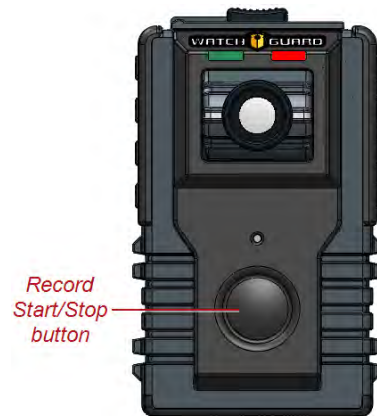

*VISTA/VISTA WiFi*



**Note:** A VISTA WiFi or VISTA XLT that has automatically started an event behaves in the same way.

## Stopping a recorded event manually



**Note:** The VISTA Body Camera can be configured to NOT allow manual event stop. If you cannot manually stop the camera, when you press a **Record Start/Stop** button, two low tones sound with a vibration (depending on your alert notification selections) and the display reads **IGNORED** for 3 seconds.

To manually stop a recorded event on the VISTA Body Camera:

- Press a **Record Start/Stop** button.



**Important!** You may need to press a **Record Start/Stop** button a second time within 5 seconds to confirm the event stop, depending on your configuration.

The **REC** icon turns off on the display and the red LED turns off. Descending tones sound with a vibration (depending on your alert notification selections).

After a recorded event has stopped, if event categorization is required as part of the camera's configuration, the event categorization sequence starts. For instructions how to categorize a recorded event, see *Categorizing a Recorded Event* on **page 29**.



**Note:** A VISTA WiFi or VISTA XLT that has automatically stopped an event behaves in the same way.

The VISTA Body Camera can be configured to stop a recorded event automatically after a period of time. For more information, see *Maximum Recorded Event Time* on **page 76**.

**Tip:** Even if VISTA WiFi or VISTA XLT is NOT configured to require an event-stop confirmation (second press of a **Record Start/Stop** button within 5 seconds), you need to confirm an event stop in the following scenario:



VISTA WiFi or VISTA XLT automatically starts an event because a member of the local recording group reports that it started a recorded event. You immediately (within 10 seconds) press a **Record Start/Stop** button to STOP the recorded event because you do not want VISTA WiFi or VISTA XLT to record it. The camera requests that you press a **Record Start/Stop** button again to confirm that you want to STOP the recorded event. If you do not press the button a second time within 5 seconds, VISTA WiFi or VISTA XLT continues to record the event.

## Muting the Audio During a Recorded Event



**Note:** The ability to mute a VISTA Body Camera during a recorded event is set up as part of a configuration in WatchGuard Evidence Library software.

You can use the **Display Backlight** button on the VISTA Body Camera to mute the audio during a recorded event. The **Display Backlight** button is on the right side as you look at the front of the VISTA, VISTA WiFi, or VISTA XLT DVR.

If the camera is configured to allow muting, when you press and hold down the **Display Backlight** button during an event, the camera mutes the event audio. As long as you continue to hold the **Display Backlight** button, the audio is muted. When you release the button, the event audio continues normally.

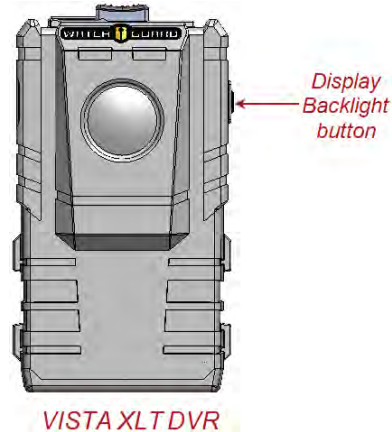

### Muting audio

To mute audio during a recorded event:

1. Press and hold down the **Display Backlight** button.
2. Continue to hold down the **Display Backlight** button as long as you want the event audio to remain muted.

The display reads **MUTED** while you hold down the **Display Backlight** button.

The camera's audio unmutes when you release the **Display Backlight** button.



**Tip:** You cannot mute the audio while you are categorizing a recorded event. Selecting a category requires that you hold down the same button (**Display Backlight**) you hold down for muting. Once you have finished categorizing, you can again mute the audio. For information on categorizing a recorded event on the VISTA Body Camera, see *Categorizing a Recorded Event* on [page 29](#).

## Categorizing a Recorded Event



**Note:** Event categorization is set up as part of a configuration in WatchGuard Evidence Library software.

You use the **Display Backlight** button on the VISTA Body Camera to select a category to apply to a recorded event. The **Display Backlight** button is on the right side as you look at the front of the VISTA, VISTA WiFi, or VISTA XLT DVR.

If the camera is configured to require categorization, when you stop an event, the display immediately prompts you to select an event category.

**If your VISTA WiFi or VISTA XLT is a member of a recording group**, the camera can automatically accept an event category from the 4RE DVR group member as its own category. However, any category selected directly on VISTA WiFi or VISTA XLT overrides the 4RE category. For more information on recording groups, see *Using VISTA WiFi or VISTA XLT with a Recording Group* on **page 79**.

**If your VISTA WiFi or VISTA XLT is connected to the VISTA SmartConnect smartphone app**, you can categorize an event using SmartConnect. Any category selected on SmartConnect overrides a 4RE category. If you categorize an event on both the VISTA WiFi camera and the smartphone app, the last selected category, regardless of the device, will be applied to the event. For more information on using the smartphone app, see *Categorizing Recorded Events* on **page 99**.

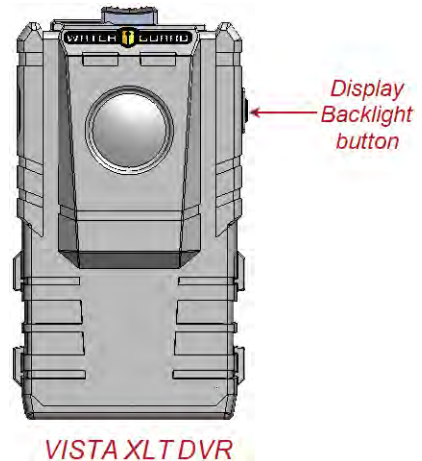

## Categorizing a recorded event on the camera

To categorize a recorded event:

1. Stop the event manually or allow VISTA WiFi or VISTA XLT to stop the event automatically.  
The display shows the **Category** prompt.
2. Press and release the **Display Backlight** button as many times as needed to move through the list of available event categories, one at a time.
3. Press and hold the **Display Backlight** button for at least 2 seconds when the event category you want to select shows on the display.  
The display reads **SAVED** and shows which category you selected. One long tone sounds with a vibration (depending on your alert notification selections).

If another recorded event starts (manually or automatically) while the camera is in the middle of the event categorization sequence, the camera aborts the sequence and starts the new event. You will be able to categorize the recorded event later in your Evidence Library software, if necessary.

## Docking the VISTA Body Camera

---

WatchGuard offers three different bases where you can dock your VISTA Body Camera:

- USB Base ([page 31](#))
- VISTA Transfer Station ([page 33](#))
- VISTA WiFi Base ([page 34](#))

Docking the camera allows you to perform the following tasks:

- Upload recorded events from storage ([page 37](#))
- Upgrade firmware ([page 40](#))
- Charge the battery ([page 42](#))

Use the USB Base or the Transfer Station inside your agency when fully charging the battery.

Use the WiFi Base in the vehicle for incidental charging during your shift. Charging in a vehicle base can impact the vehicle battery and can slow down significantly in warmer temperatures.



**Important!** Battery charging shuts down at ambient temperatures greater than 35 degrees C (95 degrees F).

---

- Provision the camera (USB Base and Transfer Station only) ([page 35](#))
- Define a Record-After-the-Fact<sup>®</sup> (RATF) event (USB Base only) ([page 39](#))
- Request a state capture for troubleshooting (USB Base only)
- Associate with a recording group that can include a 4RE DVR and other VISTA WiFi or VISTA XLT cameras (WiFi Base only) ([page 44](#))

The VISTA Body Camera needs to interact with Evidence Library software to be customized for your agency. For that interaction to take place, the camera must be docked in a VISTA USB Base or Transfer Station connected to your Evidence Library software.

You can dock any VISTA Body Camera in any of the three bases.

## Docking the VISTA Body Camera in a USB Base

When you dock the VISTA Body Camera in a USB Base connected to Evidence Library software:



**Caution:** To prevent possible damage to some computers, connect the USB Base to the computer through the approved USB hub (Sabrent 7-Port USB 2.0 Hub, WatchGuard part number WGP02364).

- The camera's battery begins to charge, if needed
- VISTA's time and date synchronize with the Evidence Library system, if needed (VISTA only)



**Important!** VISTA (no Wi-Fi® and GPS) sets its internal date and time from the Evidence Library software's computer. If the computer's date and time is set incorrectly, VISTA's will be set incorrectly, and your video evidence will be marked with the incorrect date and time.

- The camera's firmware upgrades, if a firmware upgrade has been staged on the camera
- The camera communicates to the Evidence Library software that it has recorded events to upload
- Recorded events are uploaded to the Evidence Library software
- The Evidence Library software sends commands and/or requests to the camera as applicable:
  - Mark any imported recorded events as import confirmed
  - Update the configuration
  - Stage a firmware upgrade
  - Generate an RATF event
  - Generate a state capture

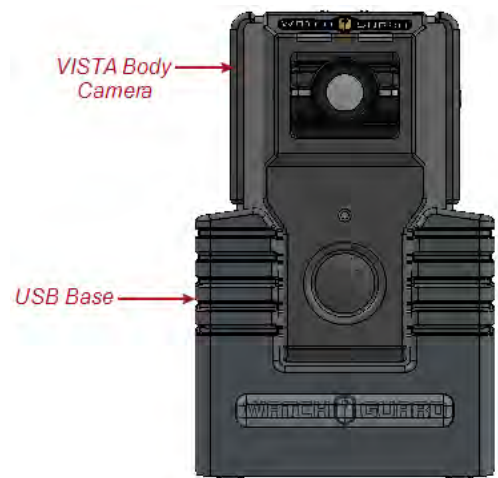

When you undock the camera from the USB Base, it processes the Evidence Library software commands and requests before it is ready for normal operation.

## Undocking the camera from the USB Base

Evidence Library software commands and requests are only applied when the camera is undocked from a USB Base. When you undock the camera, it processes the commands and requests in the following order, as applicable:

1. Performs a state capture.

The display reads **STATE CAPTURE**.

2. Updates the configuration.

The display reads **CONFIG**. The configuration update alert sounds when the update is finished.

3. Generates an RATF event.

The display reads **CREATING RATF**.



**Note:** After the RATF event has been generated, the camera starts the event categorization sequence for the RATF event if it is configured to require event categorization. For instructions how to categorize an event, see *Categorizing a Recorded Event* on **page 29**.

---

4. Unprotects the recorded events confirmed as imported.

This makes the storage space available to be reused as needed.

5. Stages the firmware upgrade to perform the next time the camera is docked.

Once all the commands and requests are processed, VISTA is ready for normal operation.

For more information about the USB Base, see *USB Base* on **page 64**.



## Docking the VISTA Body Camera in a VISTA Transfer Station



**Note:** The VISTA Transfer Station must be set up and configured to be used with your Evidence Library software. For instructions how to set up the Transfer Station, see Appendix D: VISTA Transfer Station Setup on [page 117](#).

When you dock the VISTA Body Camera in a Transfer Station connected to Evidence Library software:

- The camera's battery begins to charge, if needed
- VISTA's time and date synchronize with the Evidence Library system, if needed (VISTA only)



**Important!** VISTA (no Wi-Fi® and GPS) sets its internal date and time from the Evidence Library software's computer. If the computer's date and time is set incorrectly, VISTA's will be set incorrectly, and your video evidence will be marked with the incorrect date and time.

- The camera's firmware upgrades, if a firmware upgrade has been staged on the camera
- The camera communicates to the Evidence Library software that it has recorded events to upload
- Recorded events are uploaded to the Evidence Library software
- Evidence Library software sends commands and/or requests to the camera as applicable:
  - Mark any imported recorded events as import confirmed

The events confirmed as imported are immediately unprotected. This makes the storage space available to be reused as needed.

- Update the configuration

**If the configuration is manually pushed** to the camera (through the Evidence Library checkout process), the configuration is updated immediately.

**If the configuration is automatically pushed** to the camera, the configuration is updated after the camera is undocked.

- Stage a firmware upgrade

The firmware upgrade is staged on the camera immediately, and then is applied the next time the camera is docked.

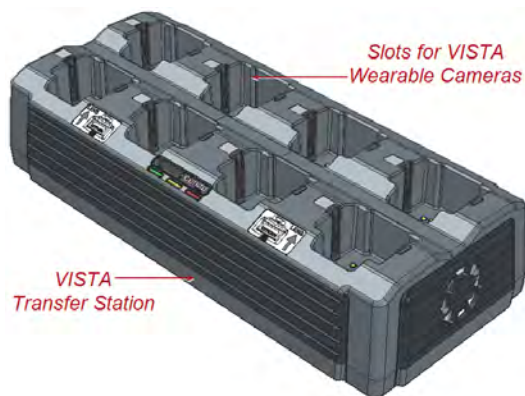

When you undock the camera from the Transfer Station, it is ready for normal operation.

For more information about the Transfer Station, see *VISTA Transfer Station* on [page 65](#).

## Docking the VISTA Body Camera in a WiFi Base



**Note:** Not all VISTA Body Cameras or VISTA bases have the Wi-Fi® feature. For more information, contact your WatchGuard representative.

When you dock the VISTA Body Camera in a VISTA WiFi Base:

- The camera's battery begins to charge, if needed
- The camera's firmware upgrades, if a firmware upgrade has been staged on the camera
- VISTA WiFi or VISTA XLT pairs with the WiFi Base; when it does, it becomes associated with the local recording group (VISTA WiFi and VISTA XLT only)

When the camera becomes associated with the local recording group, it is disassociated from any other recording group.



When you dock the VISTA Body Camera in a VISTA WiFi Base that is connected to an Evidence Library 4 Web upload server:



**Note:** WatchGuard recommends that you use version 4.2 (or later) of EL4 Web for the best experience.

- The camera communicates to EL4 Web that it has recorded events to upload  
The camera must be configured to upload events directly to EL4 Web from the WiFi Base.
- Recorded events are uploaded to EL4 Web
- EL4 Web sends commands and/or requests to the camera as applicable:
  - Mark any imported recorded events as import confirmed  
The events confirmed as imported are immediately unprotected. This makes the storage space available to be reused as needed.
  - Stage a firmware upgrade  
The firmware upgrade is staged on the camera immediately, and then is applied the next time the camera is docked.

When you undock the camera from the WiFi Base, it is ready for normal operation.

*For more information about...*

The WiFi Base, see *VISTA WiFi Base* on **page 66**.

Recording groups, see *Using VISTA WiFi or VISTA XLT with a Recording Group* on **page 79**.

Upgrading the WiFi Base, see *Upgrading the VISTA WiFi Base and the Smart Power Switch* on **page 115**.

## Provisioning the camera

---



**Tip:** Before using the VISTA Body Camera for the first time, fully charge and provision it.

---

You provision your VISTA Body Camera while it is docked in a USB Base or VISTA Transfer Station. When you provision the camera, you use your WatchGuard Evidence Library software to assign a configuration and an officer name.

Depending on how your agency assigns its cameras, you may need to provision and check out the camera each time you use it (for example, from a pool of cameras) or only rarely as its configuration needs to be updated (for example, if a camera has been assigned to you long-term).

To provision the VISTA Body Camera:

1. Dock the camera in the USB Base or Transfer Station connected to your Evidence Library software.
2. Using Evidence Library software, create and/or assign a configuration and an officer to the docked camera.

For instructions how to assign a configuration and officer to the camera, see your Evidence Library software documentation.

As a configuration is applied to the camera, the display reads **CONFIG**. The configuration update alert sounds when the update is finished.

### VISTA Body Camera configuration

You can only create a VISTA Body Camera configuration in your Evidence Library software.

---



**Note:** For instructions how to create and set up a configuration for the VISTA Body Camera, see your Evidence Library software documentation.

---

Some of the configuration properties you can set up for the VISTA Body Camera in your Evidence Library software include:

- Agency or department name
- Time zone where the agency or department is located
- Officer name and badge ID
- Device ID
- Event tags including a list of possible event categories ([page 29](#))
- Officer preferences for indicators, including ([page 57](#))
  - Alert preference (none, tone, vibration, or tone and vibration together)
  - LED brightness
  - Tone volume

## Using the VISTA Body Camera

- VISTA WiFi and VISTA XLT behaviors, including
  - Recording group interactions (**page 79**)
  - Allowing connection to the VISTA SmartConnect smartphone app
- Network preferences, including
  - Allowing the camera to upload to Evidence Library 4 Web (EL4 Web) when docked in a VISTA WiFi Base (EL4 Web only)
  - Maximum wireless upload time (EL4 Web only)
- Recording preferences, including
  - Video quality and frame rate
  - Enabling Record-After-the-Fact® (RATF) (**page 72**)
  - Forcing microphone on all the time (**page 73**)
  - Allowing audio muting (**page 28**)
  - Disabling VISTA audio completely
  - Enabling pre-event capture (**page 71**)
  - Enabling split events
  - Requiring confirmation of recorded event stop
- Power- and storage-saving preferences, including
  - Allowing sleep (**page 74**)
  - Allowing automatic power off (**page 75**)
  - Enabling maximum recorded event time (**page 76**)
  - Enabling recording reminder alerts (**page 77**)

## Uploading events

You can upload recorded events from your VISTA Body Camera while it is docked in any of the three bases:

- USB Base

You can upload recorded events automatically or manually from a camera in a USB Base, depending on the settings in your Evidence Library software. While the camera is uploading from a USB Base, you can monitor its upload progress in the Evidence Library software.

- VISTA Transfer Station

Events upload automatically from a camera in the VISTA Transfer Station.

- VISTA WiFi Base

Events upload from a camera (typically VISTA WiFi or VISTA XLT) in the WiFi Base, only if the WiFi Base is connected to an Evidence Library 4 Web (EL4 Web) upload server. The events upload automatically.

With the VISTA Body Camera version 3.0.2, events can upload from a camera in the WiFi Base over a cellular LTE connection to the EL4 Web upload server.



**Note:** WatchGuard supports upload over a cellular connection using the Sierra Wireless® AirLink® MG90 High Performance Multi-Network Vehicle Router.

---

The camera must be configured to upload events to EL4 Web from the WiFi Base.



**Important!** Critical events always upload first.

---

You use your WatchGuard Evidence Library software to manage all aspects of the upload and import.

To upload recorded events from the VISTA Body Camera:

1. Dock the camera in a base or Transfer Station connected to your Evidence Library software.

The **Evidence Library software** automatically detects that the camera is **docked in a USB Base or Transfer Station** and that it has events to upload. The events begin to upload automatically if applicable.

**EL4 Web** automatically detects that the camera is **docked in a WiFi Base** and that it has events to upload. The events begin to upload automatically if applicable.

2. Follow any prompts in the Evidence Library software to upload video from the camera and import it to evidence storage.

The camera must remain docked during the upload process.

## VISTA and VISTA WiFi



**Note:** While VISTA or VISTA WiFi is uploading from the USB Base, you can monitor its upload progress in your Evidence Library software.

While VISTA or VISTA WiFi is uploading from the VISTA WiFi Base or Transfer Station:

- The display reads **XX of YY**, where **XX** is the current event being uploaded and **YY** is the total number of events to upload, and the bars on the **Storage Used** meter disappear
- The red LED fast blinks during the entire upload process

When the camera is finished uploading critical events:

- The display scrolls **CRITICAL COMPLETE** one time then returns to **XX of YY**
- The red LED continues to fast blink during the entire upload process
- One long tone sounds

When the camera is finished uploading all events:

- The display scrolls **UPLOAD COMPLETE**
- Two long tones sound

## VISTA XLT



**Note:** While VISTA XLT is uploading from the USB Base, you can monitor its upload progress in your Evidence Library software.

While VISTA XLT is uploading from the VISTA WiFi Base or Transfer Station:



- The display:
  - First line reads **Uploading XX/YY** where **XX** is the current event being uploaded and **YY** is the total number of events to upload
  - Second line shows the percentage of saved storage already uploaded next to a progress bar representing the total number of events to upload; the progress bar includes a **Critical Complete** indicator
  - Third line reads **CRITICAL EVENTS XX/YY**, where **XX** is the current critical event being uploaded and **YY** is the total number of critical events to upload, or **NON-CRITICAL EVENTS**
- The red LED fast blinks during the entire upload process

When the camera is finished uploading critical events:

- The third line of the display reads **CRITICAL COMPLETE** for 5 seconds, then reads **NON-CRITICAL EVENTS** for the duration of the upload
- One long tone sounds



When the camera is finished uploading all events:

- The display reads **Uploading YY EVENTS COMPLETE** for 5 seconds, where **YY** is the total number of events uploaded
- Two long tones sound



### *Record-After-the-Fact® events*

If the VISTA Body Camera is configured with Record-After-the-Fact (RATF) enabled and it is docked in a USB Base, you can use the Evidence Library software to define and request an RATF event from the camera. (An RATF event usually consists of video that was not originally part of a recorded event.) The camera generates the RATF event after you undock it, then uploads the RATF event the next time you dock for upload.

### *Clearing video out of camera storage*

Once the VISTA Body Camera has successfully uploaded its recorded events to evidence storage using Evidence Library software, the camera no longer protects that storage space. It can be used for future recorded events.

### *For more information about...*

How to import video from the VISTA Body Camera to your evidence storage, see your Evidence Library software documentation.

The VISTA Body Camera and RATF events, see *Record-After-the-Fact®* on **page 72**.

Recorded events, see *Video, Audio, and Subtitle Evidence* on **page 46**.

## Upgrading firmware

You can push new firmware to the VISTA Body Camera while it is docked in any of the bases:

- USB Base  
You can push an upgrade automatically or manually when it is docked in a USB Base, depending on the settings in your Evidence Library software.
- VISTA Transfer Station  
You can push an upgrade automatically when it is docked in a VISTA Transfer Station.
- VISTA WiFi Base  
You can push an upgrade to the VISTA Body Camera (typically VISTA WiFi or VISTA XLT) when it is docked in a VISTA WiFi Base, ONLY IF the WiFi Base is connected to an Evidence Library 4 Web (EL4 Web) upload server. The upgrade is pushed automatically.

When an upgrade is pushed to the camera, the firmware is first **staged** on the camera, then the next time the camera is docked, the upgrade is **applied**.

To upgrade the VISTA Body Camera's firmware:

1. Dock the camera in a base or Transfer Station connected to your Evidence Library software.  
The Evidence Library software automatically detects that the camera is docked and that its firmware needs to be upgraded.
2. Using Evidence Library software, make sure the new firmware is pushed to the camera.



**Note:** Evidence Library software can be set up to push new firmware manually or automatically. For instructions, see your Evidence Library software documentation.

---

The new firmware is staged on the camera.

3. The **next time** you dock the camera, the upgrade is applied.

The camera MUST remain docked while the upgrade is being applied. The camera cannot perform any other function, including uploading video, while it is upgrading its firmware.



**Warning!** DO NOT REMOVE the camera from the dock while its new firmware is being applied. Removing the camera from the dock during the upgrade can cause the camera to stop functioning.

---



## VISTA and VISTA WiFi



**Note:** If a VISTA or VISTA WiFi is docked in a USB or WiFi Base while the upgrade is being staged on the camera, the display does not show the staging process.

While the **upgrade is being staged** on a VISTA or VISTA WiFi in a Transfer Station, the display:

- **Storage Used** meter fills with bars and **Storage Percentage** increases
- 8-character area scrolls **DOWNLOADING**

When the **upgrade has finished staging**, the **Storage Used** meter is full, the **Storage Percentage** shows **100%**, and the 8-character area scrolls **DOWNLOAD COMPLETE** for about 5 seconds.

The **next time** you dock the camera in the USB Base, WiFi Base, or the Transfer Station, the upgrade is applied. While the **upgrade is being applied**, **UPDATING DO NOT INTERRUPT** scrolls on the display.



**Warning!** DO NOT REMOVE the camera from the dock while its new firmware is being applied. Removing the camera from the dock during the upgrade can cause the camera to stop functioning.

When the **upgrade has finished applying**, the camera sounds the camera ready alert (depending on your alert notification selections).

## VISTA XLT



**Note:** If the VISTA XLT is docked in a USB or WiFi Base while the upgrade is being staged on the camera, the display does not show the staging process.

While the **upgrade is being staged** on a VISTA XLT in a Transfer Station, the display:

- First line reads **Upgrade**
- Second line shows the percentage of the upgrade already downloaded next to a progress bar
- Third line reads **DOWNLOADING**



When the **upgrade has finished staging** on the camera, the percentage downloaded and progress bar show **100%**, and the third line reads **DOWNLOAD COMPLETE** for 5 seconds.



If VISTA XLT is undocked and not recording, and has an upgrade staged on the camera, the **Upgrade Staged** icon (🔒) appears in the lower right corner of the display.

The **next time** you dock the camera in the USB Base, WiFi Base, or the Transfer Station, the upgrade is applied. While the **upgrade is being applied**, the display:

- First line reads **Upgrading**
- Second line shows a status bar
- Third line reads **DO NOT INTERRUPT**



**Warning!** *DO NOT REMOVE the camera from the dock while its new firmware is being applied. Removing the camera from the dock during the upgrade can cause the camera to stop functioning.*

When the **upgrade has finished applying**, the camera reboots. The third line of the display reads **REBOOTING**.



*For more information about...*

Upgrading the VISTA WiFi Base and the Smart Power Switch, see *Upgrading the VISTA WiFi Base and the Smart Power Switch* on **page 115**.

## Charging the battery



**Tip:** *Before using the camera for the first time, fully charge and provision it.*

The VISTA Body Camera charges any time it is docked, if it needs to charge. VISTA and VISTA WiFi's batteries can fully charge in 3 to 5 hours. VISTA XLT's battery can fully charge in about 7 hours.

To fully charge the camera:

- Dock the camera in either the USB Base or the VISTA Transfer Station inside your agency.

The camera can charge in a USB Base connected to the USB port on a computer, depending on the amount of power provided by the USB port. The camera charges significantly faster when docked in a USB Base that is plugged into an electrical outlet or in a Transfer Station.



**Caution:** *To prevent possible damage to some computers, connect the USB Base to the computer through the approved USB hub (Sabrent 7-Port USB 2.0 Hub, WatchGuard part number WGP02364).*

WatchGuard recommends that you use the USB Base or the Transfer Station inside your agency when fully charging the VISTA Body Camera's battery. Charging in a vehicle base can impact the vehicle battery and can slow down significantly in warmer temperatures. For the best battery life and fastest charging times, you should charge the VISTA Body Camera in a cooler environment.



**Important!** Battery charging shuts down at ambient temperatures greater than 35 degrees C (95 degrees F).

## VISTA and VISTA WiFi

While VISTA and VISTA WiFi are charging:

- The display alternates between **CHARGING** and the **Device ID**, and the **Battery Charge** icon animates
- The green LED blinks



When the cameras are fully charged:

- The display scrolls **CHARGE COMPLETE** once, then continuously shows the **Device ID**, and the **Battery Charge** icon shows five bars
- The green LED lights steadily
- Two tones sound



## VISTA XLT

As VISTA XLT charges:

- The display shows the **Battery Charge** percentage growing, the **Battery Charge** icon filling, and a lightning bolt next to the icon, blinking
- The green LED on the DVR blinks



When the camera is fully charged:

- The display shows **100%** and a fully-filled **Battery Charge** icon for a few seconds, then alternates between the **Officer Name** and the **Device ID**
- The green LED on the DVR lights steadily
- Two tones sound



For more information about VISTA Body Camera batteries, see *Battery* on **page 59**.

## VISTA WiFi and VISTA XLT: Associating with a recording group

When you dock VISTA WiFi or VISTA XLT in a VISTA WiFi Base, the camera pairs with the WiFi Base. This pairing allows the camera to associate with the local recording group that includes the WiFi Base. The recording group can also include other VISTA WiFi or VISTA XLT cameras and the local 4RE DVR. A recording group is typically linked to a vehicle.



**Note:** *You can pair more than one camera with the same WiFi Base.*

---

When VISTA WiFi or VISTA XLT is associated with a recording group, it can participate in group recordings. A group recording is multiple devices collaborating to start and stop their recorded events together. When a group recording is uploaded, each device's event is linked to the other group members' events.

To associate VISTA WiFi or VISTA XLT with a recording group:

- Dock the camera in a VISTA WiFi Base that is connected to a local recording group.

The WiFi Base left LED blinks green multiple times when the camera and base have successfully paired. When the camera is undocked, the display shows **Wi-Fi Signal Strength** bars (VISTA WiFi) or a partially filled triangle (VISTA XLT) when the camera is paired with and in range of the WiFi Base.

Once the camera is paired with the base, it is associated with the local recording group (and is disassociated from any other recording group).

For more information on recording groups, see *Using VISTA WiFi or VISTA XLT with a Recording Group* on **page 79**.

## About the VISTA Body Camera

*In this section...*

- Video, audio, and subtitle evidence (**page 46**)
- Camera components
  - VISTA and VISTA WiFi (**page 48**)
  - VISTA XLT (**page 52**)
- The bases
  - USB Base (**page 64**)
  - VISTA Transfer Station (**page 65**)
  - VISTA WiFi Base (**page 66**)

## Overview

---

The VISTA Body Camera:

- Captures, processes, and stores video and audio evidence (below)
- Functions as a camera and DVR (digital video recorder) combination
  - VISTA (**page 48**)
  - VISTA WiFi (**page 48**)
  - VISTA XLT (**page 52**)
- Can be docked in any of three bases (USB, Transfer Station, WiFi) for charging and uploading, and two of the three (USB, Transfer Station) for provisioning
  - USB Base (**page 64**)
  - VISTA Transfer Station (**page 65**)
  - VISTA WiFi Base (**page 66**)
- Can be paired with a VISTA WiFi Base for charging, uploading, and associating with a recording group (VISTA WiFi and VISTA XLT only) (**page 66**)

## Video, Audio, and Subtitle Evidence

---

The VISTA Body Camera works as a DVR and camera combination to collect evidence in the form of recorded events. A recorded event is a unique, protected segment of recorded:

- Video (**page 47**)
- Audio (**page 47**)
- Subtitles (**page 47**)

When you press a **Record Start/Stop** button to start and then stop a recording, the VISTA Body Camera protects the video/audio segment between the two button presses as a recorded event.

**If your VISTA WiFi or VISTA XLT is a member of a recording group**, the camera can also start or stop a recorded event automatically when alerted by another group member that the other group member has started or stopped an event. VISTA WiFi and VISTA XLT protect the segment between the automatic start and stop in the same way they protect the segment between the manual button presses. Both protected segments are recorded events.



**Note:** *If you are not sure whether your equipment includes the Wi-Fi® feature, contact your WatchGuard representative.*

---

Depending on the configuration applied to the camera, it may be capturing video all the time or only during a recorded event. If the camera is capturing video all the time (Record-After-the-

Fact® (RATF) is enabled), only the protected segment (between the manual or automatic start and stop) is considered a recorded event.



---

**Tip:** *If the camera is configured with RATF enabled, you may be able to use your Evidence Library software to send a manual request to the camera to retrieve an RATF event: video that was not originally part of a recorded event. For more information about retrieving an RATF event from the VISTA Body Camera, see your Evidence Library software user guide.*

---

If the camera is configured to enable pre-event video, a recorded event also includes that pre-event time.

Normally, only recorded events are uploaded to your Evidence Library software.

## Video

The VISTA Body Camera records one stream of video and compresses it using h.264 high-profile compression. Depending on the configuration applied to the camera, the video quality can be:

- High definition (HD), 720p, at a frame rate of 5, 10, 15, or 30 frames per second
- or
- Standard definition (SD), 480p, at a frame rate of 5, 10, 15, or 30 frames per second

## Audio

The VISTA Body Camera records CD quality audio with minimal distortion and wind noise. Depending on the configuration applied to the camera, it can:

- Continuously record audio
- or
- Only record audio during recorded events

## Subtitles

Subtitles are the text information that can be overlaid on the video. The VISTA Body Camera includes the following subtitles:

- Officer name
- Date and time
- Device ID
- Microphone on or off
- GPS location (VISTA WiFi or VISTA XLT only)



---

**Tip:** *The subtitles are always included with the video and audio in a recorded event, but using your Evidence Library software, you can turn them off or on.*

---

*For more information about...*

The RATF special feature, see *Record-After-the-Fact*® on **page 72**.

Pre-event video, see *Pre-Event Capture* on **page 71**.

Provisioning the camera with a configuration, see *Provisioning the camera* on **page 35**.

Importing VISTA Body Camera recorded events to Evidence Library software, see *Uploading events* on **page 37**.

Recording groups, see *Using VISTA WiFi or VISTA XLT with a Recording Group* on **page 79**.

## VISTA and VISTA WiFi

---

VISTA is an all-in-one HD body camera that does not include Wi-Fi® or GPS. VISTA WiFi is an all-in-one HD camera that includes Wi-Fi and GPS.

VISTA and VISTA WiFi components include:

- Camera sensor and lens (**page 49**)
- Microphone (**page 49**)
- Buttons (**page 49**)
  - Power
  - Record Start/Stop
  - Display Backlight
- Display (**page 50**)
- Feedback indicators (**page 57**)
  - Tones
  - Vibration
  - LEDs
- Storage (**page 57**)
- Battery (**page 59**)
- Wi-Fi (VISTA WiFi only) (**page 61**)
- GPS (VISTA WiFi only) (**page 62**)
- Quick mounting latch (**page 59**)

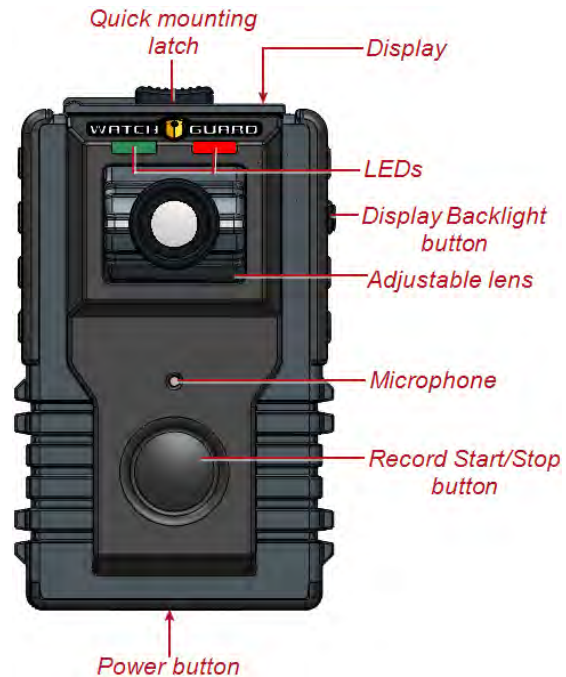

**Note:** If you are not sure whether your equipment includes the Wi-Fi feature, contact your WatchGuard representative.

---



## Camera sensor and lens

The camera sensor for VISTA and VISTA WiFi is an ultra-wide dynamic range (U-WDR) image sensor. This sensor:

- Maintains rich colors at all light levels
- Increases low-light sensitivity

The 130-degree wide-angle lens rotates vertically +/-20 degrees. Position the lens aiming at the horizon.

## Microphone

VISTA and VISTA WiFi use a digital microphone to record CD quality sound with minimal distortion and wind noise.

Depending on the configuration applied to the camera, the microphone:

- Continuously records audio (default setting)
- or
- Only records audio when you press the **Record Start/Stop** button

You can mute the microphone, depending on the camera's configuration, using the **Display Backlight** button. For more information, see *Muting the Audio During a Recorded Event* on [page 28](#).

## Buttons

VISTA and VISTA WiFi have three buttons that control the camera's functionality:

- **Power** button
- **Record Start/Stop** button
- **Display Backlight** button



### Power button

Use the **Power** button to power the camera on or off as well as place it in Covert Mode. The **Power** button is on the bottom of the camera.

For instructions how to power the camera on and off, see *Powering On and Off* on [page 24](#). For more information about placing the camera in Covert Mode, see *Covert Mode* on [page 77](#).



### Record Start/Stop button

Use the **Record Start/Stop** button to start or stop a recorded event on the camera. The **Record Start/Stop** button is on the front of the camera.

For instructions how to start and stop a recorded event on the camera, see *Starting and Stopping a Recorded Event* on **page 26**.

### Display Backlight button

Use the **Display Backlight** button for multiple functions, including:

- Turning on the backlight for the camera's display
- Showing the camera's status on the display
- Aborting the sequence of status information on the display
- Muting the audio during a recording (see *Muting the Audio During a Recorded Event* on **page 28**)
- Selecting an event category to assign to a recording (see *Categorizing a Recorded Event* on **page 29**)
- Turning on VISTA WiFi's access point (hotspot) for the SmartConnect smartphone application (see *Appendix A: Using VISTA SmartConnect* on **page 89**)
- Canceling the sleep warning period (see *Sleep Power State* on **page 74**)
- Canceling the maximum recording time warning period (see *Maximum Recorded Event Time* on **page 76**)

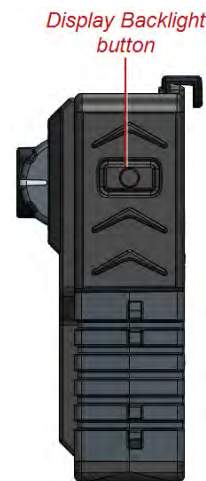

The **Display Backlight** button is on the right side as you look at the front of the camera.

## Display

The display on VISTA and VISTA WiFi shows a number of icons and messages to indicate the status of the camera. The icons show in the top half of the display; the messages show in the 8-character area on the bottom half of the display. If a message is longer than 8 characters, the message scrolls. The display is on the top of the camera.

The display informs you of:

- **Battery status**

As the charge level decreases, the number of bars in the **Battery Charge** icon decreases (see *Battery* on [page 59](#)).

- **Current recording length**

The recorded event length shows in the form HH:MM:SS, for example, **1:23:59**, and includes any configured pre-event time (see *Pre-Event Capture* on [page 71](#)).

- **Date and time**

The date shows as an abbreviation for the month with a 1- or 2-digit day of the month, for example, **NOV 3**.

- **Event categories**

Each category shows in the 8-character area as you cycle through the list, for example, **DOMESTIC**. If the item is longer than 8 characters, the item scrolls. The list of categories is configured in your Evidence Library software (see *Categorizing a Recorded Event* on [page 29](#)).

- **Number of recorded events in storage**

- **Officer name**

- **Recording status**

The **REC** icon (●REC) shows whether the camera is currently recording.

- **Saved storage total**

The saved storage total shows as a decimal value in GB, for example, **11.07 GB**.

- **Storage status**

As the camera storage fills with recorded events, the **Storage Used** meter fills with bars and the **Storage Percentage** increases (see *Storage* on [page 57](#)).

- **Upload status**, if docked in the VISTA Transfer Station or the VISTA WiFi Base

The upload status shows the number of events uploaded out of the total number of events to upload. Critical events upload first (see *Uploading events* on [page 37](#)).

- **Wi-Fi or GPS signal status** (VISTA WiFi only)

Most of the time, the **Wi-Fi Signal Strength** icon shows the status of VISTA WiFi's Wi-Fi connection with the WiFi Base (see *VISTA WiFi Base* on [page 66](#)). During the status information sequence (shows on the display when you press the **Display Backlight** button), the **Wi-Fi Signal Strength** icon shows the status of the GPS signal (see *GPS* on [page 62](#)).

When the camera is not recording, the default message shown on the display is the number of recorded events in storage. When the camera is in Covert Mode and not recording, the default shown on the display is **COVERT**. When the camera is recording, the default shown on the display is the current recording length.

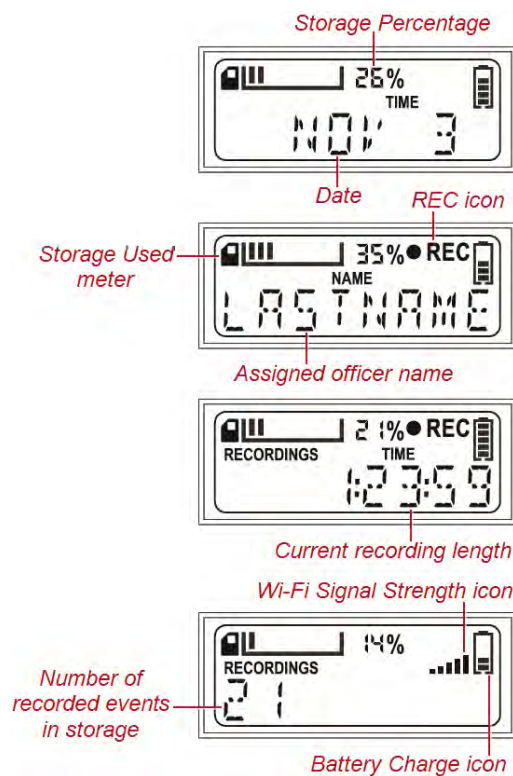

## VISTA XLT

VISTA XLT is a two-piece body-worn camera system with an HD camera sensor separate from the camera DVR. It includes Wi-Fi® and GPS.

VISTA XLT components include:

- Camera sensor (below)
  - Lens
  - Microphone
- Buttons (**page 53**)
  - Power
  - Two (2) Record Start/Stop (DVR and camera sensor)
  - Display Backlight
- Display (**page 54**)
- Feedback indicators (**page 57**)
  - Tones
  - Vibration
  - LEDs
- Storage (**page 57**)
- Battery (**page 59**)
- Wi-Fi (**page 61**)
- GPS (**page 62**)
- Quick mounting latch (**page 59**)

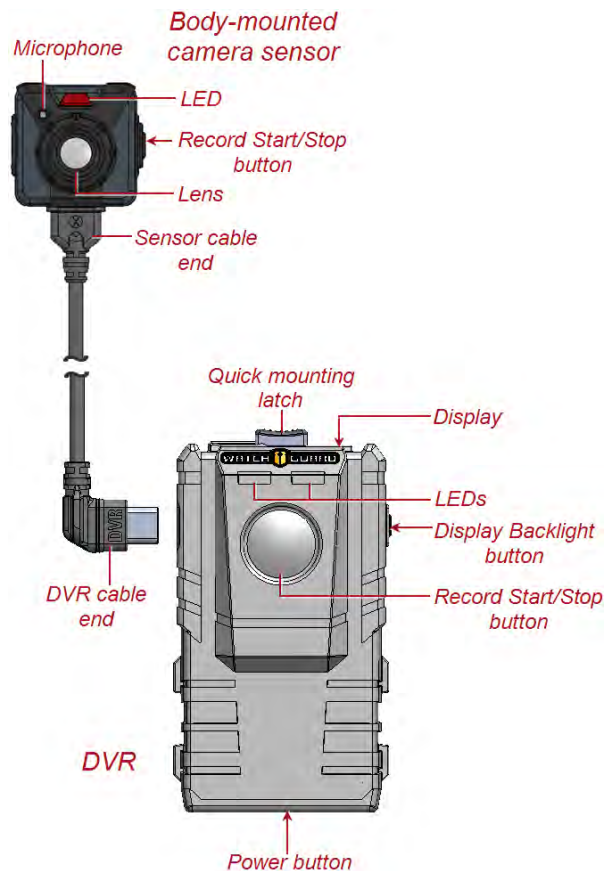

### Camera sensor

The VISTA XLT HD camera sensor holds the lens and the microphone for the VISTA XLT camera system. WatchGuard offers two HD camera sensors for the VISTA XLT:

- Head-mounted
- Body-mounted

VISTA XLT's sensor is an ultra-wide dynamic range (U-WDR) image sensor. This sensor:

- Maintains rich colors at all light levels
- Increases low-light sensitivity



VISTA XLT uses a digital microphone to record CD quality sound with minimal distortion and wind noise. Depending on the configuration applied to the camera, the microphone:

- Continuously records audio
- or
- Only records audio when you press the **Record Start/Stop** button

You can mute the microphone, depending on the camera's configuration, using the **Display Backlight** button. For more information, see *Muting the Audio During a Recorded Event* on [page 28](#).

## Buttons

VISTA XLT has four buttons that control the camera's functionality:

- **Power** button
- Two (2) **Record Start/Stop** buttons
- **Display Backlight** button

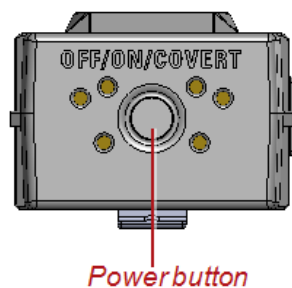

### Power button

Use the **Power** button to power VISTA XLT on or off as well as place it in Covert Mode. The **Power** button is on the bottom of the DVR.

For instructions how to power the camera on and off, see *Powering On and Off* on [page 24](#). For more information about placing the camera in Covert Mode, see *Covert Mode* on [page 77](#).

### Record Start/Stop button

Use either **Record Start/Stop** button to start or stop a recorded event on VISTA XLT. One **Record Start/Stop** button is on the front of the DVR, the other is on the side of either camera sensor.

For instructions how to start and stop a recorded event on the camera, see *Starting and Stopping a Recorded Event* on [page 26](#).

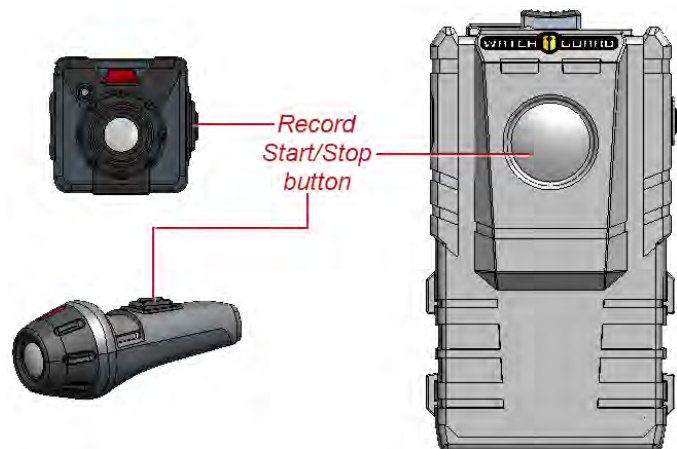

## Display Backlight button

Use the **Display Backlight** button for multiple functions, including:

- Turning on the backlight for the camera's display
- Showing the camera's status on the display
- Advancing through the sequence of status information on the display
- Muting the audio during a recording (see *Muting the Audio During a Recorded Event* on **page 28**)
- Selecting an event category to assign to a recording (see *Categorizing a Recorded Event* on **page 29**)
- Turning on VISTA XLT's access point (hotspot) for the SmartConnect smartphone application (see *Appendix A: Using VISTA SmartConnect* on **page 89**)
- Canceling the sleep warning period (see *Sleep Power State* on **page 74**)
- Canceling the maximum recording time warning period (see *Maximum Recorded Event Time* on **page 76**)

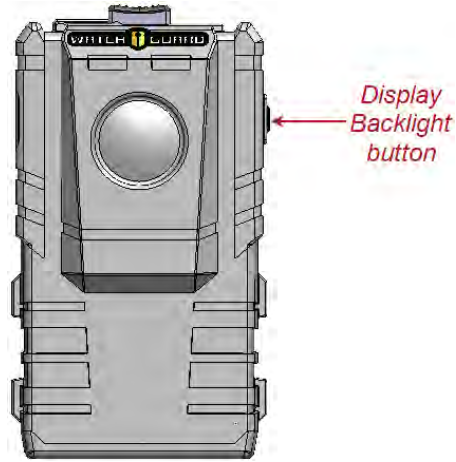

The **Display Backlight** button is on the right side as you look at the front of the DVR.

## Display

The display on VISTA XLT can show a number of icons and messages to indicate the status of the camera. When the icons are present, they show in the top half of the display. Messages can show on any part of the display. The display is on the top of the camera.

The display informs you of:

- **Battery status**  
The **Battery Charge** icon and percentage show the charge level of the battery (see *Battery* on **page 59**).
- **Current event length**  
The recorded event length shows in the form HH:MM:SS, for example, **1:23:59**, and includes any configured pre-event time (see *Pre-Event Capture* on **page 71**).
- **Date and time**
- **Device ID**

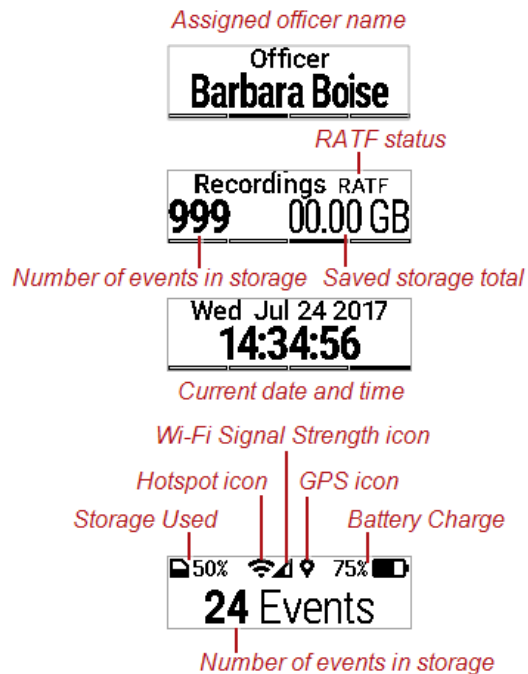

- **Event categories**

Each category shows in the display as you cycle through the list, for example, **DOMESTIC**. The list of categories is configured in your Evidence Library software (see *Categorizing a Recorded Event* on [page 29](#)).

- **GPS status**

The presence of the **GPS** icon shows that the camera currently has GPS lock.

- **Hotspot status**

The presence of the **Hotspot** icon shows that the hotspot is currently on.

- **Number of recorded events in storage**

- **Officer name**

- **RATF status**

**RATF** on the **Recordings** information screen shows that RATF (Record-After-the-Fact®) is enabled.

- **Recording status**

The **REC** icon shows whether the camera is currently recording.

- **Saved storage total**

The saved storage total shows as a decimal value in GB, for example, **11.07 GB**.

- **Storage status**

The **Storage Used** icon and percentage show how much storage has been used for recorded events (see *Storage* on [page 57](#)).

- **Upload status**, if docked in the VISTA Transfer Station or the VISTA WiFi Base

The upload status shows the number of events uploaded out of the total number of events to upload. Critical events upload first and are listed separately on the **Uploading** screen (see *Uploading events* on [page 37](#)).

- **Wi-Fi signal status**

The **Wi-Fi Signal Strength** icon shows the status of VISTA XLT's Wi-Fi connection with the WiFi Base (see *VISTA WiFi Base* on [page 66](#)).

When the camera is not recording, the default message shown on the display is the number of recorded events in storage. When the camera is in Covert Mode and not recording, the default shown on the display is **COVERT**. When the camera is recording, the default shown on the display is the current event length.



Rec icon      Current event length

Percentage of saved storage uploaded  
Events uploaded/Total events



Critical Complete indicator  
Critical events uploaded/Total critical events



## Information Sequence

---

The information sequence is a set of informational screens the VISTA Body Camera uses to give you the current status of the camera. The information sequence shows on the display automatically as part of the bootup process when you power the camera on. You can also bring up the information sequence on-demand.

### VISTA and VISTA WiFi

On VISTA and VISTA WiFi, you press the **Display Backlight** button once to start the information sequence. The screens appear in the following order:

1. Number of recorded events in storage
2. Total saved storage in GB
3. Officer name
4. 24-hour time in the format HH:MM:SS
5. Date in the format MMM DD

MMM is the abbreviation for month, for example, **JAN**.

You can press the **Display Backlight** button at any point to abort the rest of the information sequence.

### VISTA XLT

On VISTA XLT, you press the **Display Backlight** button twice within 2 seconds to start the information sequence. The screens appear in the following order:

1. Number of recorded events in storage and total saved storage in GB  
This screen also shows **RATF** if RATF is enabled in the device configuration.
2. Officer name
3. Date in the format DDD MMM DD YYYY and 24-hour time in the format HH:MM:SS  
DDD is the abbreviation for the day name, for example, **MON**. DD is the abbreviation for the date number, for example, **15**. MMM is the abbreviation for month, for example, **JAN**.
4. Device ID

You can press and release the **Display Backlight** button to manually advance through information sequence screens. Without manually advancing the sequence, each screen stays on the display about 4 seconds.



## Feedback indicators

---

Apart from the displays, all models of VISTA Body Camera can provide feedback on their status using:

- Tones
- Vibration
- Red and green LEDs

All of these feedback indicators are configurable in your Evidence Library software. You can set up the tones and vibration to alert with:

- Tone only
- Vibration only
- Tone and vibration together
- No tone or vibration

You can configure the brightness level of the LEDs or set them to adjust automatically depending on the time of day.



**Note:** *If you place the camera in Covert Mode, no tones sound and the LEDs do not light. VISTA XLT inverts its display. For information about placing the camera in Covert Mode, see Covert Mode on [page 77](#).*

---

## Storage

---

The VISTA Body Camera can store about 12 hours of HD (high definition) video.

When you need to free up storage space on the camera, you upload recorded events from the camera to your Evidence Library software. For information about uploading events to Evidence Library, see *Uploading events* on [page 37](#).

The VISTA Body Camera offers some special features to help you conserve storage space. For more information, see *Battery and storage saving special features* on [page 70](#).

## VISTA and VISTA WiFi

VISTA and VISTA WiFi's display shows a **Storage Used** meter and a **Storage Percentage** to indicate how much of the storage has been used for protected video/audio (recorded events). As the camera records events and its storage fills, the **Storage Used** meter fills with bars and the **Storage Percentage** number increases. For information about protected video/audio, see *Video, Audio, and Subtitle Evidence* on **page 46**.



When the meter shows bars, video evidence has been saved in storage. The **Storage Percentage** number shows the corresponding percentage of storage used.

When the **Storage Used** meter shows all ten bars, storage is more than 90 percent full (the **Storage Percentage** number will show **91%** or higher). You should dock the camera to import video to your Evidence Library software as soon as possible.



## VISTA XLT

VISTA XLT's display shows a **Storage Used** icon and percentage to indicate how much of the storage has been used for protected video/audio (recorded events). As the camera records events and its storage fills, the **Storage Used** icon fills with black and the percentage increases. For information about protected video/audio, see *Video, Audio, and Subtitle Evidence* on **page 46**.



When the icon has any black filled in, video evidence has been saved in storage. The percentage shows the corresponding percentage of storage used.

When the icon is completely filled with black, storage is more than 90 percent full (the percentage will show **91%** or higher). You should dock the camera to import video to your Evidence Library software as soon as possible.

## Low storage and full storage messages

When the camera is about 10 minutes away from running out of storage space, it alerts you with:

- Two short tones and/or a vibration (depending on the alert configuration settings)
- Slow-blinking red LED and **Storage Used** meter/icon on the display

When the camera storage is full, it alerts you again with an error condition alert:

- Fast-blinking red LED
- Three short tones and/or a vibration (depending on the alert configuration settings)
- Error message on the display



**Warning!** If storage fills completely, the camera stops recording new video.

## Battery

The VISTA Body Camera uses a lithium-polymer (LiPo) battery.

WatchGuard recommends that you use the USB Base, connected to an electrical outlet, or the VISTA Transfer Station when fully charging the VISTA Body Camera battery.



**Caution:** To prevent possible damage to some computers, connect the USB Base to the computer through the approved USB hub (Sabrent 7-Port USB 2.0 Hub, WatchGuard part number WGP02364).

Charging in a vehicle base can impact the vehicle battery and can slow down significantly in warmer temperatures. For the best battery life and fastest charging times, you should charge the VISTA Body Camera in a cooler environment.



**Important!** Battery charging shuts down at ambient temperatures greater than 35 degrees C (95 degrees F).

The VISTA Body Camera offers a number of special features to help you conserve battery power. For more information, see *Battery and storage saving special features* on **page 70**.

## VISTA and VISTA WiFi

The VISTA and VISTA WiFi batteries can fully charge in 3 to 5 hours when docked in a USB Base connected to an electrical outlet or in a VISTA Transfer Station.

VISTA is available in two battery versions:

- Standard capacity battery  
VISTA with the standard capacity battery weighs 4.3 ounces and can continuously record HD (high definition) quality video for about 7 hours.
- Extended capacity battery  
VISTA with the extended capacity battery weighs 5.3 ounces and can continuously record HD quality video for about 11 hours.

VISTA WiFi is only available with the extended capacity battery and can continuously record HD quality video for:

- About 9 hours with GPS enabled
- About 10 hours with GPS disabled

The camera's display shows a **Battery Charge** icon that indicates the charge level of the battery. When the icon shows the battery with all five bars, the battery is fully charged. When the icon shows fewer than five bars, the charge level of the battery is less than fully charged.



When the **Battery Charge** icon shows only the outline, the battery charge is less than 10 percent; in this case, you should dock VISTA to charge as soon as possible. For instructions how to charge the VISTA battery, see *Charging the battery* on **page 42**.



When VISTA has nearly run out of battery power (less than 5 percent of full capacity remaining), the camera alerts you with:

- Two tones and/or a vibration (depending on VISTA's alert configuration settings)
- Slow-blinking red LED and **Battery Charge** icon on the display

## VISTA XLT

VISTA XLT's battery can fully charge in about 7 hours when docked in a USB Base connected to an electrical outlet or in a VISTA Transfer Station.

The DVR part of the VISTA XLT system contains the battery. The DVR weighs 6.2 ounces and can continuously record the highest HD quality video for:

- About 10 hours with GPS enabled
- About 12 hours with GPS disabled

VISTA XLT's display shows a **Battery Charge** icon and percentage that indicate the charge level of the battery. When the icon is completely filled and the percentage shows **100%**, the battery is fully charged.



As the battery is used, the icon slowly empties and the percentage lowers. When the battery charge is less than 10 percent, you should dock the camera to charge as soon as possible. For instructions how to charge the VISTA XLT battery, see *Charging the battery* on **page 42**.



When VISTA XLT has nearly run out of battery power (less than 5 percent of full capacity remaining), the camera alerts you with:

- Two tones and/or a vibration (depending on the camera's alert configuration settings)
- Slow-blinking red LED and **Battery Charge** icon/percentage on the display

## LOW BATT/LOW BATTERY message

The **LOW BATT** (VISTA and VISTA WiFi) or **LOW BATTERY** (VISTA XLT) message appears on the display when you push the **Power** button to power the camera up, but the battery charge level is so low that the camera cannot successfully power up. You should dock the camera (VISTA and VISTA WiFi) or DVR (VISTA XLT) to charge as soon as possible.

## LOW BASE message

The **LOW BASE** message appears on the display when the camera (VISTA and VISTA WiFi) or DVR (VISTA XLT) is docked, but the dock is not providing enough power to charge the camera.

If the camera is docked in a USB Base, make sure the base is connected to an electrical outlet. The VISTA Body Camera can charge in a USB Base connected to the USB port on a computer,

depending on the amount of power provided by the USB port. The camera charges significantly faster when docked in a USB Base plugged into an electrical outlet.



**Caution:** To prevent possible damage to some computers, connect the USB Base to the computer through the approved USB hub (Sabrent 7-Port USB 2.0 Hub, WatchGuard part number WGP02364).

If the camera is docked in a Transfer Station, move the camera to another slot in the Transfer Station. If the camera continues to read **LOW BASE** in the Transfer Station, contact WatchGuard Customer Service.

## OVERTEMP message

The **OVERTEMP** message appears on the display when the camera (VISTA and VISTA WiFi) or DVR (VISTA XLT) is docked, but the battery is unable to charge due to excessive heat. The camera will continue to try to charge as it cools down.



**Important!** Battery charging shuts down at ambient temperatures greater than 35 degrees C (95 degrees F).



**Tip:** For the best battery life and fastest charging times, WatchGuard recommends that you charge the VISTA Body Camera in a cooler environment.

## Wi-Fi



**Note:** Not all VISTA Body Cameras or VISTA bases have the Wi-Fi® feature. If you are not sure whether your equipment has Wi-Fi, contact your WatchGuard representative.

The VISTA WiFi and VISTA XLT cameras include built-in Wi-Fi (802.11n).



**Note:** VISTA WiFi and VISTA XLT also include GPS capability. For more information, see GPS on [page 62](#).

The Wi-Fi feature allows VISTA WiFi and VISTA XLT to pair with the VISTA WiFi Base. Once the camera and the base are paired, the camera is associated with the local recording group. For more information about pairing VISTA WiFi and VISTA XLT with the WiFi Base, see *VISTA WiFi and VISTA XLT: Associating with a recording group* on [page 44](#).

The Wi-Fi feature also allows VISTA WiFi and VISTA XLT to operate as a Wi-Fi access point (hotspot) for the VISTA SmartConnect smartphone application.

## VISTA WiFi

When VISTA WiFi is paired with the WiFi Base, the camera display shows a **Wi-Fi Signal Strength** icon () that indicates the strength of the Wi-Fi signal coming from the WiFi Base.

## VISTA XLT

When VISTA XLT is paired with the WiFi Base, the camera display shows a **Wi-Fi Signal Strength** icon () that indicates the strength of the Wi-Fi signal coming from the WiFi Base.

When VISTA XLT is operating as a hotspot for the SmartConnect app, the camera display shows a **Hotspot** icon ()

*For more information about...*

Recording groups, see *Using VISTA WiFi or VISTA XLT with a Recording Group* on **page 79**.

Connecting SmartConnect with the camera, see *Appendix A: Using VISTA SmartConnect* on **page 89**.

## GPS

---

The VISTA WiFi and VISTA XLT cameras include built-in GPS (Global Positioning System).



**Note:** VISTA WiFi and VISTA XLT also include Wi-Fi capability. For more information, see *Wi-Fi* on **page 61**.

---

VISTA WiFi and VISTA XLT use the GPS feature to apply:

- Accurate timestamps to recorded events  
These timestamps allow your Evidence Library software to synchronize playback between events (video and/or audio) from VISTA WiFi or VISTA XLT cameras and/or 4RE DVRs.
- GPS location coordinates to VISTA WiFi and VISTA XLT recorded events

Both the timestamps and the location coordinates are included in the subtitles during playback in your Evidence Library software.



**Note:** The GPS feature can be disabled in your Evidence Library software configuration, if you need to conserve power.

---

## VISTA WiFi

When the VISTA WiFi GPS finds its first lock after powering up, the camera display shows **GPS LOCK** for 5 seconds.

If GPS is enabled on VISTA WiFi, you can see the status of a VISTA WiFi's GPS signal during the status information sequence. The information sequence shows on the display when you press the **Display Backlight** button.

During the information sequence, VISTA WiFi uses the bars of the **Wi-Fi Signal Strength** icon to communicate the camera's GPS lock status:

- **0 bars:** GPS has never locked since the camera's last reboot
- **1 bar:** GPS has locked at least one time since the camera's last reboot, but is NOT currently locked
- **5 bars:** GPS is actively locked

## VISTA XLT

When the VISTA XLT GPS finds its first lock after powering up, the camera display shows **GPS LOCK** for 5 seconds.

When VISTA XLT has GPS lock, the camera display shows the **GPS** icon (📍).

## Quick mounting latch

---

The quick mounting latch on VISTA and VISTA WiFi attaches to the mounting tab on any of their mount options. The quick mounting latch on the VISTA XLT DVR attaches to DVR mounting options.

Slide the latch over the tab on the mount to attach or release the camera.

For more information about mounting options for VISTA and VISTA WiFi, see *Wearing VISTA and VISTA WiFi* on **page 15**.

For more information about mounting options for VISTA XLT, see *Wearing VISTA XLT* on **page 19**.



## USB Base

---

When you dock the VISTA Body Camera in the USB Base, the camera automatically starts charging, if needed. The camera also uses the USB Base for:

- Uploading recorded events from storage
- Provisioning the camera
- Updating firmware
- Defining a Record-After-the-Fact® (RATF) event
- Requesting a state capture for troubleshooting

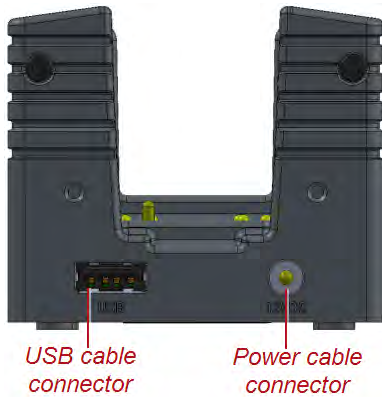

### Connections

The USB Base has connections for both a power cable and a USB cable. For instructions how to set up the VISTA USB Base, see *Setting up the VISTA USB Base* below.

For more information about using the VISTA Body Camera with the USB Base, see *Docking the VISTA Body Camera in a USB Base* on **page 31**.

## Setting up the VISTA USB Base

To set up the USB Base to use with a VISTA Body Camera and your Evidence Library software:



**Caution:** To prevent possible damage to some computers, connect the USB Base to the computer through the approved USB hub (Sabrent 7-Port USB 2.0 Hub, WatchGuard part number WGP02364).

1. Set up the approved USB hub and connect it to the computer where your Evidence Library software is located.
2. Plug the power cable for the USB Base into an electrical outlet.
3. Connect the power cable to the USB Base.
4. Connect the USB cable to the USB Base and then into the approved USB hub.



## VISTA Transfer Station

When you dock the VISTA Body Camera in the VISTA Transfer Station, the camera automatically starts charging, if needed. The camera also uses the Transfer Station for:

- Uploading recorded events from storage
- Provisioning the camera
- Updating firmware automatically

The VISTA Transfer Station allows your agency's Evidence Library software to interact with multiple VISTA Body Cameras simultaneously. You can connect multiple Transfer Stations to one instance of Evidence Library software.

Each Transfer Station has eight slots for cameras.

### LEDs

Three LEDs on the Transfer Station show power and connection status:

- **Green, left position:** When lit, indicates that the Transfer Station is powered on
- **Amber, center position:** When lit, indicates that the Transfer Station is connected to Evidence Library software; when blinking, indicates data is being transferred
- **Red, right position:** When lit, indicates an error condition

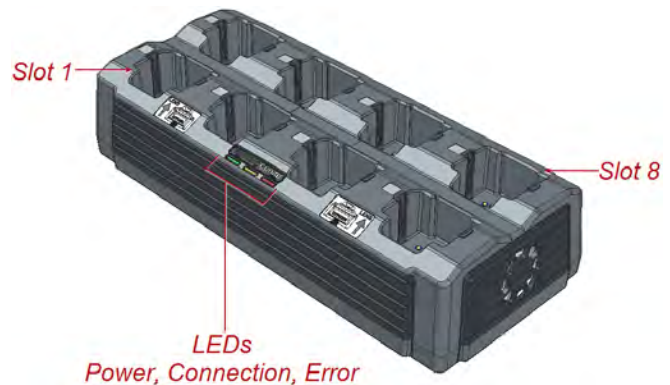

### Connections

The Transfer Station has connections for both a power cable and an Ethernet cable. You power the Transfer Station off and on using the power switch.

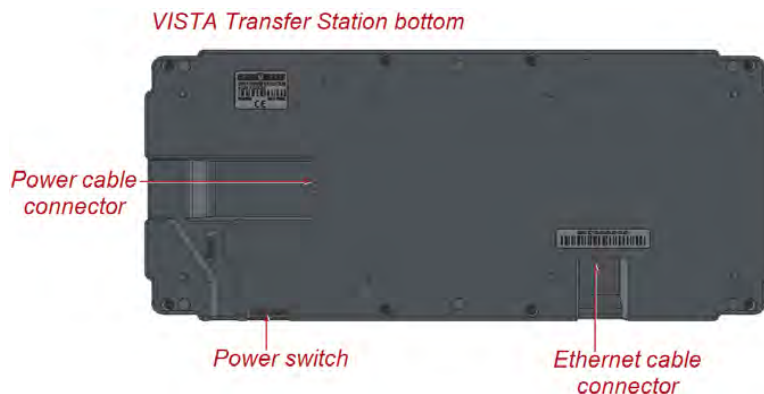

For more information about using VISTA Body Cameras with the Transfer Station, see *Docking the VISTA Body Camera in a VISTA Transfer Station* on **page 33**.

## Setting up the VISTA Transfer Station

For instructions how to set up the VISTA Transfer Station, see *Appendix D: VISTA Transfer Station Setup* on **page 117**.

## VISTA WiFi Base

---



**Note:** Not all VISTA Body Cameras or bases have the Wi-Fi® feature. For more information, contact your WatchGuard representative.

---

When you dock the VISTA WiFi or VISTA XLT camera in the VISTA WiFi Base, the camera pairs with the base. The camera can use the WiFi Base for:

- Associating with a local recording group  
The WiFi Base acts as the Wi-Fi access point (802.11n hotspot) for VISTA WiFi or VISTA XLT to connect to the local recording group network. The broadcast range for the WiFi Base depends on its current environment.

- Updating firmware
- Uploading recorded events from storage (only with an Evidence Library 4 Web connection)

- Charging the camera's battery

You should only use the WiFi Base for incidental charging during your shift.

Charging in a vehicle base can impact the vehicle battery and can slow down significantly in warmer temperatures.



**Important!** Battery charging shuts down at ambient temperatures greater than 35 degrees C (95 degrees F).

---

## LEDs

Two bi-color LEDs on the front of the WiFi Base show power and connection status. The left LED is either red or green.

Left LED (red/green)	
LED state	VISTA WiFi Base state
Off	Powered off
Red	Undefined
Green	Powered on
Blinking red	Error condition
Blinking green	In shutdown or wireless upload timeout period

The left LED on the WiFi Base blinks green a number of times when it successfully pairs with a VISTA WiFi or VISTA XLT camera. The left LED blinks red a number of times if the pairing was not successful.

The right LED is either green or amber.

Right LED (green/amber)		
LED state	VISTA WiFi docked state	VISTA WiFi Base state
Off	---	Not connected to camera or upload server
Amber	Docked	Connected to upload server
Green	Not docked	Connected to camera (Wi-Fi connection)
Blinking amber	Docked	Activity with upload server
Blinking green	Not docked	Activity with camera (Wi-Fi connection)

If two cameras are paired with the same VISTA WiFi Base, and one is docked, the WiFi Base LEDs show the state of the DOCKED camera and WiFi Base pair.

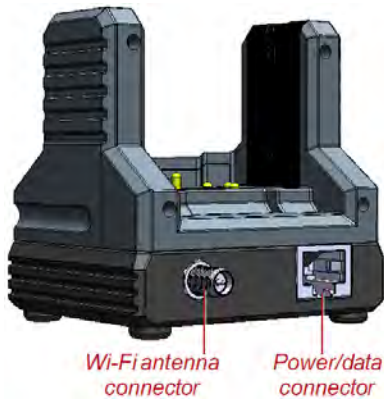

## Connections

The WiFi Base has connections for a Wi-Fi antenna cable and a WatchGuard-provided custom power/data cable on the back.

The WiFi Base power/data cable must connect to the Smart Power Switch. For more information about the WiFi Base as part of the local recording group network, see *Using VISTA WiFi or VISTA XLT with a Recording Group* on **page 79**.

*For more information about...*

Using VISTA WiFi or VISTA XLT with the WiFi Base, see *Docking the VISTA Body Camera in a WiFi Base* on **page 34**.

Upgrading the WiFi Base, see *Upgrading the VISTA WiFi Base and the Smart Power Switch* on **page 115**.

## Setting up the VISTA WiFi Base

Typically, the VISTA WiFi Base, its windshield antenna, and the Smart Power Switch are installed in the vehicle by your agency's installation technicians. For more information about installing the VISTA WiFi system equipment in the vehicle, see the *4RE Vehicle Installation Instructions*.

## VISTA Body Camera Special Features

*In this section...*

- Pre-Event Capture (**page 71**)
- Record-After-the-Fact® (**page 72**)
- Force Microphone On (**page 73**)
- Sleep power state (**page 74**)
- Automatic Off (**page 75**)
- Maximum Recorded Event Time (**page 76**)
- Recording Reminder Alert (**page 77**)
- Covert Mode (**page 77**)

## Overview

---

The VISTA Body Camera has a number of special features that give you more recording options and can help you save battery power and storage. The camera also has a Covert Mode that turns off the camera tones and LEDs.

### Recording special features

The VISTA Body Camera has the following special features related to recording:

- **Pre-Event Capture:** Enable this feature to allow the camera to capture and save up to two minutes of additional video prior to a recorded-event start ([page 71](#))
- **Record-After-the-Fact®:** Enable this feature to allow the camera to continuously capture and save video that can generate a Record-After-the-Fact (RATF) event ([page 72](#))
- **Force Microphone On:** Enable this feature to allow the camera to capture audio whenever it is capturing and saving video ([page 73](#))



**Note:** All of the recording special features are configured in your Evidence Library software.

---

### Battery and storage saving special features

The VISTA Body Camera has the following special features related to saving battery power and storage space:

- **Sleep power state:** Enable this feature to allow the camera to enter a low power state after a period of time with no activity ([page 74](#))  
This feature can help save battery power.
- **Automatic Off:** Enable this feature to allow the camera to turn itself off after a period of time with no activity ([page 75](#))  
This feature can help save battery power.
- **Maximum Recorded Event Time:** Enable this feature to allow the camera to automatically stop a recorded event when it reaches a specified duration ([page 76](#))  
This feature can help save storage space.
- **Recording Reminder Alert:** Enable this feature to allow the camera to notify you at regular intervals that it is still capturing a recorded event ([page 77](#))  
This feature can help save storage space.



**Note:** All of the battery and storage saving special features are configured in your Evidence Library software.

---

## Covert Mode

With Covert Mode enabled, the VISTA Body Camera sounds no tones, lights no LEDs, and only lights the Display Backlight on demand. For instructions how to enable Covert Mode on the camera, see *Covert Mode* on [page 77](#).

## Pre-Event Capture

---

The Pre-Event Capture feature on the VISTA Body Camera allows you to capture and save up to two minutes of additional video prior to a recorded-event start. You configure the Pre-Event Capture feature in your Evidence Library software.

If the Pre-Event Capture feature is enabled, the camera is continuously capturing and saving video whenever it is powered on and not asleep. When an event is started, manually or automatically, up to two minutes of that saved video is added to the recorded event prior to the event start time.



**Note:** *VISTA WiFi and VISTA XLT can start a recorded event automatically when associated with a recording group. For more information about starting events, see *Starting and Stopping a Recorded Event* on [page 26](#).*

---

For example, you start a recorded event (by pressing **Record Start/Stop**) at 2:15 PM and stop it (again pressing **Record Start/Stop**) at 2:35 PM. With a Pre-Event Capture time configured for one minute, the recorded event includes video recorded from 2:14 PM to 2:35 PM.

For the Pre-Event Capture feature, in your Evidence Library software, you configure how much pre-event time you want captured, from none up to two minutes.

## Audio

Audio is NOT typically included with pre-event video. Typically, the VISTA Body Camera only begins to record audio when you start a recorded event.

You can include audio whenever the camera is recording if you enable the Force Microphone On feature. For information about this feature, see *Force Microphone On* on [page 73](#).

*For more information about...*

Recorded events, see *Video, Audio, and Subtitle Evidence* on [page 46](#).

Recording groups, see *Using VISTA WiFi or VISTA XLT with a Recording Group* on [page 79](#).

## Record-After-the-Fact<sup>®</sup>

---

The Record-After-the-Fact (RATF) feature on the VISTA Body Camera allows you to continuously capture and save video you can use to generate an RATF event. You enable the RATF feature in your Evidence Library software.

The VISTA Body Camera works as a DVR and camera combination to collect evidence in the form of recorded events. When a recording is started and then stopped, automatically or manually, the camera protects the segment between the recording start and stop as a recorded event.



**Note:** *VISTA WiFi or VISTA XLT can start and stop a recorded event automatically when associated with a recording group. For more information about starting and stopping events, see Starting and Stopping a Recorded Event on page 26.*

---

When you enable the RATF feature on the VISTA Body Camera, the camera captures and stores video whenever it is powered on and not asleep; however, only the protected segment between the event start and stop (automatic or manual) is considered a recorded event. Typically, only recorded events are uploaded to your Evidence Library software.

For the RATF feature, in your Evidence Library software, you configure whether you want the camera to continuously capture and save video or not.

## Generating an RATF event

If the VISTA Body Camera has the RATF feature enabled, you can use your Evidence Library software to send a manual request to the camera to generate and retrieve an RATF event. An RATF event typically consists of video that was not originally part of a recorded event. For more information about generating and retrieving an RATF event, see your Evidence Library software user guide.



**Note:** *The Evidence Library software can only send an RATF event request to a VISTA Body Camera docked in the USB base.*

---

## Storage

When RATF is enabled, the camera overwrites the oldest unprotected (non-recorded event) area in storage with any newly captured video or recorded events. This process can continue until the camera's storage is filled with recorded events (protected recordings). Then you must upload recorded events to your Evidence Library software to free up storage space before you can continue to use the camera.



## Audio

Audio is NOT typically included in the saved video when RATF is enabled. Typically, the VISTA Body Camera only begins to record audio when a recorded event is started. This means that audio is NOT typically included with RATF video that was not originally part of a recorded event (protected recording).

You can include audio whenever the camera is capturing and saving video if you enable the Force Microphone On feature. For information about this feature, see *Force Microphone On* below.

### *For more information about...*

Recorded events, see *Video, Audio, and Subtitle Evidence* on **page 46**.

Recording groups, see *Using VISTA WiFi or VISTA XLT with a Recording Group* on **page 79**.

## Force Microphone On

---

The Force Microphone On feature of the VISTA Body Camera allows you to capture audio whenever the camera is capturing and saving video. You enable the Force Microphone On feature in your Evidence Library software.

Typically, audio is only captured during a recorded event. This means that even though the camera may be configured to capture video all the time, if a recorded event is not started, automatically or manually, the camera does not record audio. (Audio is NOT typically included in pre-event video or Record-After-the-Fact® (RATF) events.)

When you enable the Force Microphone On feature, the camera captures audio with the video whenever it is capturing and saving video. This means that audio IS included with both pre-event video and RATF events.

For the Force Microphone On feature, in your Evidence Library software, you configure whether you want the VISTA Body Camera to capture audio whenever it is capturing and saving video or not.

### *For more information about...*

Recorded events, see *Video, Audio, and Subtitle Evidence* on **page 46**.

Pre-event video, see *Pre-Event Capture* on **page 71**.

RATF events, see *Record-After-the-Fact®* on **page 72**.

Recording groups, see *Using VISTA WiFi or VISTA XLT with a Recording Group* on **page 79**.

## Sleep Power State

---

The Sleep power state on the VISTA Body Camera allows the camera to go into a low-power state designed to help you conserve battery power. You configure the Sleep state in your Evidence Library software.

When the VISTA Body Camera is configured for Sleep state, after a period of time with no movement and/or button presses, the camera enters a low power state where it cannot capture any video or audio.

The Sleep power state provides a significant reduction in power consumption. Starting with a fully charged battery, the VISTA Body Camera can remain in its Sleep power state for more than 30 hours before powering off due to a discharged battery.

For Sleep state, in your Evidence Library software you configure:

- Whether the camera will sleep or not
- What makes the camera sleep (lack of movement and/or button presses)
- How much time must elapse with no activity before the camera goes to sleep

When the camera is asleep, the display reads **SLEEP** and the green LED blinks slowly. The display continues to show battery and storage status indicators.

### Sleep warning period

About 15 seconds before it goes to sleep, the camera warns you that it is about to go into Sleep state:

- Descending tones sound with vibration (depending on the configured alert notification options)
- **SLEEP** blinks on the display

You can press the **Display Backlight** button or the **Record Start/Stop** button at any time to keep the camera from going to sleep.



**Note:** Pressing the **Record Start/Stop** button also starts a recorded event.

---

### Exiting Sleep state

The VISTA Body Camera exits Sleep state when you move it or press a button. From Sleep state, the camera is ready to record in about 1 second.

## Automatic Off

---

The Automatic Off feature on the VISTA Body Camera allows the camera to turn itself off after a period of time with no activity. You configure the Automatic Off feature in your Evidence Library software.

If the Automatic Off feature is enabled, after a period of time with no movement and/or button presses, the camera powers off.

For the Automatic Off feature, in your Evidence Library software you configure:

- Whether the camera will power off automatically or not
- What makes the camera power off (lack of movement and/or button presses)
- How much time must elapse with no activity before the camera powers off

As the VISTA Body Camera powers down, the display reads **Shutting Down**, the green LED turns off, and descending tones sound (depending on the configured alert notification options).

### Automatic off warning period

About 15 seconds before it automatically powers off, the camera warns you that it is about to power off:

- Descending tones sound with vibration (depending on the configured alert notification options)
- **POWER OFF** blinks on the display

You can press the **Display Backlight** button or the **Record Start/Stop** button at any time to keep the camera from going to sleep.



**Note:** Pressing the **Record Start/Stop** button also starts a recorded event.

---

## Maximum Recorded Event Time

---

The Maximum Recorded Event Time feature on the VISTA Body Camera allows the camera to automatically stop a recorded event when it reaches a specified duration. You configure the Maximum Recorded Event Time feature in your Evidence Library software.

If the Maximum Recorded Event Time feature is enabled, when a recorded event reaches the specified duration, the camera automatically stops the recorded event.

For the Maximum Recorded Event Time feature, in your Evidence Library software you configure:

- Whether the camera will have a Maximum Recorded Event Time or not
- How long a recorded event can be before the camera automatically stops it

### Maximum Recorded Event Time warning period

Two minutes before it reaches the specified Maximum Recorded Event Time, the camera warns you that it is about to stop the recorded event:

- Two tones sound with a vibration (depending on the configured alert notification options)
- **AUTOSTOP** shows on the display
- For the rest of the two-minute warning period, on the display, **AUTOSTOP** alternates with the time remaining before the recorded event stops

You can press the **Display Backlight** button to abort the warning period and keep the camera from stopping the recorded event. In this case, the camera continues recording for at least another Maximum Recorded Event Time period.

You can also press the **Record Start/Stop** button to manually stop the recorded event and abort the warning period.

## Recording Reminder Alert

---

The Recording Reminder Alert feature on the VISTA Body Camera allows the camera to notify you at regular intervals that it is still capturing a recorded event. You configure the Recording Reminder Alert feature in your Evidence Library software.

If the Recording Reminder Alert feature is enabled, the camera notifies you periodically that it is actively capturing a recorded event:

- Two tones sound with a vibration (depending on the configured alert notification options)
- The current recording duration blinks on the display with the tones/vibration, then remains on the display

For the Recording Reminder Alert feature, in your Evidence Library software, you configure:

- Whether the camera will notify you regularly that it is still recording or not
- How often the camera notifies you that it is still capturing a recorded event

## Covert Mode

---

Covert Mode on the VISTA Body Camera means that the camera sounds no tones, lights no LEDs, and only lights the Display Backlight on demand. The camera can still vibrate in Covert Mode (depending on the configured alert notification options). All VISTA Body Camera functions operate the same way in Covert Mode as they do in normal mode.

To place the camera into Covert Mode:

- Press and hold the **Power** button for more than 2 seconds but less than 15 seconds.

The camera vibrates and the display shows **READY**, then **COVERT**.

(VISTA XLT) The display on the VISTA XLT is inverted while the camera is in Covert Mode. All content on the display is the same in Covert Mode as in normal mode.



**Note:** *If the camera goes to sleep while in Covert Mode, when the camera wakes up, it is still in Covert Mode. For more information on Sleep state, see Sleep Power State on [page 74](#).*

---

To exit Covert Mode:

- Press and hold the **Power** button for more than 2 seconds but less than 15 seconds.

This page intentionally left blank.

## Using VISTA WiFi or VISTA XLT with a Recording Group

*In this section...*

- Distributed Multi-Peer Recording™ (page 80)
- Recording group members and functions (page 81)
  - Smart Power Switch (page 82)
  - 4RE DVR (page 82)
  - VISTA WiFi Base (page 83)
  - VISTA WiFi and VISTA XLT (page 84)
  - Other devices (page 85)
- Group recordings (page 85)
  - VISTA WiFi or VISTA XLT behavior (page 86)

## Overview

---

When you dock VISTA WiFi or VISTA XLT in a VISTA WiFi Base, the camera pairs with the WiFi Base. This pairing allows the camera to associate with the local recording group (**page 81**).

The association of devices in a local recording group enables the 4RE DVR and VISTA WiFi/VISTA XLT systems to collaborate in a group recording: the recording of a single incident by multiple devices (**page 85**).

The decision whether to create an event for the group recording is made by each device in the local recording group network, according to their individual configurations. This is called Distributed Multi-Peer Recording™. Starting a recorded event on one device alerts the other devices in the group that there has been a change in recording status on that device. In response, the other devices in the group start recording an event, each according to its own configuration.

When VISTA WiFi or VISTA XLT is associated with a recording group, it can participate in group recordings.



**Note:** *Not all VISTA Body Cameras or VISTA bases have the Wi-Fi® feature. If you are not sure whether your equipment has the Wi-Fi feature, contact your WatchGuard representative.*

---



## Recording groups

A recording group consists of a network of devices communicating with each other whenever one of them changes its recording status. A recording group is typically linked to a vehicle.

### Members of the recording group

A local recording group includes the following members, joined together with either wired or wireless connections:

- Smart Power Switch ([page 82](#))
- 4RE DVR, firmware version of 4.0 or later ([page 82](#))
- VISTA WiFi Base ([page 83](#))
- One or more VISTA WiFi or VISTA XLT cameras ([page 84](#))

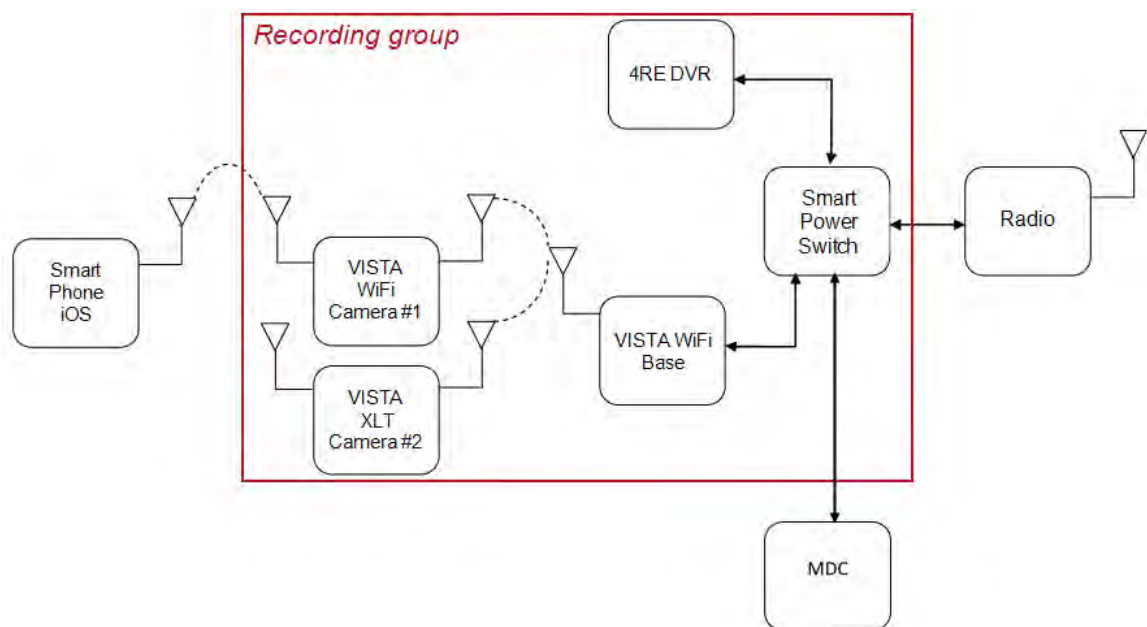

For information about installing the equipment for the recording group in a vehicle, see the *4RE Vehicle Installation Instructions*.

## Smart Power Switch

As part of the local recording group network, the Smart Power Switch:

- Functions as the central connection point  
The Smart Power Switch functions as the central wired connection point for a recording group. Through the switch, the devices connect together to form a network, allowing the 4RE and VISTA WiFi group members to communicate with each other.
- Intelligently manages power  
The switch connects to the power source (for example, the vehicle battery) and intelligently manages that power within the local recording group network. The Smart Power Switch can detect the status of the devices in the network, whether they are powered on or have powered themselves off after finishing event upload or charging. When the switch detects that the devices in the local recording group network no longer need power, it shuts down any remaining devices connected to the local network, including itself.
- Functions as the local network DHCP server  
The Smart Power Switch can also function as the DHCP server for the local recording group network and other devices connected to it (for example, wireless radio).

The Smart Power Switch is REQUIRED to form a recording group. There can only be one Smart Power Switch in a recording group.

## 4RE DVR



**Note:** The 4RE DVR must be at firmware version 4.0 or later to participate in a recording group.

---

As part of the local recording group network, the 4RE DVR:

- Initiates group recordings  
The 4RE uses the recording group network to inform the other group members when it starts a recorded event. The other group members can then join in the group recording by starting their own recorded events.  
For more information on group recordings, see *Group recordings* on **page 85**.
- Stops group recordings  
The 4RE uses the recording group network to inform the other group members when it stops a recorded event. The other group members can then stop their own recorded events.  
Only the 4RE DVR can stop a group recording. The other group members can stop their own individual recorded events; but, only the 4RE can stop all of the members' recorded events that are part of the group recording at the same time.
- Responds to group-recording starts by other group members  
Through the recording group network, the 4RE is informed by other group members when they start recorded events. 4RE can then join the group recording by starting its own recorded event.

- Passes on its event categorization to other members' recorded events in the group recording  
The category you assign on the 4RE to a recorded event that is part of a group recording is passed on to other group members' recorded events that are part of the same group recording. The other group members can choose to categorize their own recorded events, overriding any category passed to them by the 4RE.

The 4RE DVR connects to the recording group network with a wired connection into the Smart Power Switch. It also connects (wired connection) to the power source (vehicle battery).

The 4RE DVR is REQUIRED to form a recording group. There can only be one 4RE DVR in a recording group.

For more information about the 4RE DVR, see the *4RE In-Car Video User Guide*.

## VISTA WiFi Base

As part of the local recording group network, the VISTA WiFi Base:

- Pairs with VISTA WiFi or VISTA XLT  
When you dock VISTA WiFi or VISTA XLT in the VISTA WiFi Base, the camera pairs with the base. The pairing associates the camera with the local recording group.  
For more information about docking VISTA WiFi or VISTA XLT in a WiFi Base, see *Docking the VISTA Body Camera in a WiFi Base* on **page 34**.
- Acts as a Wi-Fi® access point (hotspot) to VISTA WiFi or VISTA XLT  
The VISTA WiFi Base acts as an 802.11n Wi-Fi hotspot for VISTA WiFi or VISTA XLT cameras that have paired with it.
- Notifies the recording group that a VISTA WiFi or VISTA XLT camera has started a recorded event  
The WiFi Base uses the recording group network to notify the other group members when one of its paired VISTA WiFi or VISTA XLT cameras has started a recorded event.
- Notifies VISTA WiFi or VISTA XLT that a group recording has started or stopped  
Through the recording group network, the WiFi Base is notified by other group members when they start or stop a group recording. The base then notifies VISTA WiFi or VISTA XLT, and the camera can start or stop its own recorded event with the recording group.  
For more information on group recordings, see *Group recordings* on **page 85**.

The VISTA WiFi Base connects to the recording group network with a wired connection into the Smart Power Switch. It also connects (wired connection) to a windshield antenna that allows it to connect wirelessly with VISTA WiFi or VISTA XLT.

The VISTA WiFi Base is REQUIRED to form a recording group. There can only be one VISTA WiFi Base in a recording group.

For more information about the VISTA WiFi Base, see *VISTA WiFi Base* on **page 66**.

## VISTA WiFi and VISTA XLT

As part of the local recording group network, the VISTA WiFi or VISTA XLT camera:

- Pairs with the VISTA WiFi Base

When you dock VISTA WiFi or VISTA XLT in the VISTA WiFi Base, the camera pairs with the base. The pairing associates the camera with the local recording group.

For more information about docking VISTA WiFi or VISTA XLT in a WiFi Base, see *Docking the VISTA Body Camera in a WiFi Base* on **page 34**.

- Initiates group recordings

VISTA WiFi or VISTA XLT notifies the WiFi Base that it has started a recorded event. The WiFi Base then uses the recording group network to notify the other group members that VISTA WiFi or VISTA XLT has started an event. The other group members can then join in the group recording by starting their own recorded events.

For more information on group recordings, see *Group recordings* on **page 85**.

- Responds to group-recording starts or stops by other group members

Through the recording group network, the WiFi Base is notified by other group members when they start or stop a group recording. The base then notifies VISTA WiFi or VISTA XLT, and the camera can start or stop its own recorded event with the recording group.



---

**Tip:** *If the 4RE DVR and VISTA WiFi or VISTA XLT are members of the same recording group, you can use the 4RE to control VISTA WiFi or VISTA XLT's recorded event starts, stops, and categorizations. In this case, VISTA WiFi or VISTA XLT functions like another camera connected to the 4RE DVR.*

---

VISTA WiFi or VISTA XLT connects to the recording group network with a wireless connection to the VISTA WiFi Base.



---

**Important!** *If VISTA WiFi or VISTA XLT has moved out of range of its associated recording group network, it does not receive notifications of group recording starts and stops until it is back in range. VISTA WiFi or VISTA XLT does not receive any 4RE event categorization notifications that are sent while it is out of range. For more information, see *VISTA WiFi and VISTA XLT behavior during a group recording* on **page 86**.*

---

VISTA WiFi or VISTA XLT can also provide a wireless access point (hotspot) for the VISTA SmartConnect smartphone application. For information about connecting the VISTA SmartConnect application with VISTA WiFi, see *Appendix A: Using VISTA SmartConnect* on **page 89**.

There can be multiple VISTA WiFi or VISTA XLT cameras in a recording group.

## Other devices in the system

- Radio

If present in the system, the wireless radio connects to the Smart Power Switch.

The 4RE DVR and VISTA WiFi or VISTA XLT (through the VISTA WiFi Base) can use the radio to interact with Evidence Library 4 Web (EL4 Web) through an agency network access point. The connection between the wireless radio and the agency network (EL4 Web) is independent of the local recording group network.

- MDC/laptop

If present in the system, the MDC (mobile data computer) or other laptop computer connects to the Smart Power Switch.

The computer only connects into the system through the Smart Power Switch; it is not powered through the switch. If the computer is configured to be a DHCP client, it can also get its network address from the Smart Power Switch.

- VISTA SmartConnect smartphone application

If present in the system, SmartConnect connects wirelessly to VISTA WiFi. VISTA WiFi acts as an 802.11n Wi-Fi access point (hotspot) for the smartphone.

For information about connecting the VISTA SmartConnect application to VISTA WiFi, see *Appendix A: Using VISTA SmartConnect* on **page 89**.

## Group recordings

---

When 4RE and VISTA WiFi or VISTA XLT are associated with each other in a recording group, the devices collaborate to start and stop their recorded events together. This collaboration creates a group recording: multiple devices in the same recording group creating individual recorded events of the same incident. Combined into the group recording, the individual events from different perspectives create a more comprehensive view of the incident.

For more information on recording groups and individual group members, see *Recording groups* on **page 81**.

When you upload a group recording to your Evidence Library software, the individual events are automatically linked together as a group recording. When you play back the events from the group recording, your Evidence Library software can play back one or more of them synchronized in time. For example, you can play back video from the 4RE DVR while hearing the audio from one of the VISTA WiFi cameras in the group.

For information about synchronized playback of group recordings, see your Evidence Library software documentation.

## VISTA WiFi and VISTA XLT behavior during a group recording

Any DVR device (4RE, VISTA WiFi, or VISTA XLT) in the recording group can start a recorded event. The other DVR devices in the group are informed of that change in recording status, so they can join in the group recording.

For more information on the VISTA WiFi or VISTA XLT camera's role in a recording group, see *VISTA WiFi and VISTA XLT* on **page 84**.

What happens when:

- You try to manually start a recorded event on VISTA WiFi or VISTA XLT just after it has automatically started an event as part of a group recording?

If you have pressed the **Record Start/Stop** button within 10 seconds of the automatic group recording start, VISTA WiFi or VISTA XLT asks you to confirm that you want to STOP the recorded event with your **Record Start/Stop** button press. If you do not press the **Record Start/Stop** button again within 5 seconds, the camera continues recording the event as part of the group recording.

If you press the button a second time within 5 seconds, the camera stops recording the event.

Because VISTA WiFi and VISTA XLT connect to the recording group with a Wi-Fi connection (through the WiFi Base), VISTA WiFi and VISTA XLT can move into and out of the recording group range.

What happens when:

- The VISTA WiFi or VISTA XLT that INITIATED the group recording moves out of range during the group recording?

All the devices in the recording group keep recording until the 4RE stops the group recording or each individual member stops its own event. The initiating device moving out of range does not affect the other devices' ability to start, stop, and categorize their own events.

The VISTA WiFi or VISTA XLT that went out of range keeps recording the event until it is manually stopped. A device moving out of range does not affect its ability to start, stop, and categorize its own events.

- A VISTA WiFi or VISTA XLT that is part of a group recording moves out of range during the group recording?

The VISTA WiFi or VISTA XLT keeps recording the event until it is manually stopped. A device moving out of range does not affect its ability to start, stop, and categorize its own events.

- The group recording is stopped while a VISTA WiFi or VISTA XLT that is part of that group recording is out of range?

The out-of-range VISTA WiFi or VISTA XLT keeps recording the event until it is manually stopped OR moves back into range of the group network.

When the VISTA WiFi or VISTA XLT that is still recording moves back into range, it is informed that its associated group has stopped the group recording. It then stops its own event.

- A VISTA WiFi or VISTA XLT that is not currently recording an event walks into range of an associated recording group network during a group recording?

When the VISTA WiFi or VISTA XLT moves into range, it is informed that its associated group has started a group recording. It then begins its own event to join the group recording.

- A VISTA WiFi or VISTA XLT that is currently recording an event walks into range of an associated recording group network that is NOT in a group recording?

When the VISTA WiFi or VISTA XLT moves into range, it informs its associated group that it is recording an event. The other devices in the group begin their own events to create a group recording.

*For more information about...*

Docking VISTA WiFi or VISTA XLT in the VISTA WiFi Base, see *Docking the VISTA Body Camera in a WiFi Base* on **page 34**.

Associating VISTA WiFi or VISTA XLT with a recording group, see *VISTA WiFi and VISTA XLT: Associating with a recording group* on **page 44**.

Installing VISTA WiFi or VISTA XLT equipment in the vehicle, see the *4RE Vehicle Installation Instructions*.

This page intentionally left blank.



## Appendix A: Using VISTA SmartConnect

*In this section...*

- SmartConnect Overview (**page 90**)
- Connecting VISTA WiFi or VISTA XLT to VISTA SmartConnect (**page 94**)
- Reviewing recorded event video (**page 98**)
- Categorizing recorded events (**page 99**)
- Live streaming the current VISTA view (**page 101**)
- Starting and stopping recorded events (**page 102**)
- SmartConnect settings (**page 104**)

## SmartConnect Overview

---



**Note:** The Wi-Fi® version of VISTA® and VISTA XLT™ can connect to the VISTA SmartConnect smartphone application.

---

VISTA WiFi and VISTA XLT can serve as a hotspot for the VISTA SmartConnect smartphone application. Set up the camera-to-smartphone Wi-Fi connection credentials when you check out your VISTA WiFi or VISTA XLT camera from your Evidence Library software. See *Connecting to VISTA SmartConnect* on **page 94**.

The VISTA SmartConnect app makes VISTA WiFi and VISTA XLT functionality available on your smartphone:

- Review recorded events (**page 98**)
- Categorize recorded events (**page 99**)
- Live stream the camera view (**page 101**)
- Start and stop recorded events (**page 102**)

You can adjust your camera LEDs or alert levels, enable Covert Mode, or view data about your camera. (**page 104**)



**Warning!** No evidence videos are stored on the smartphone. Snapshots stored on the phone make it subject to being confiscated as evidence. You can configure your Evidence Library software to disable the snapshot feature.

---

## Activating the VISTA WiFi or VISTA XLT hotspot

You must activate the VISTA WiFi or VISTA XLT hotspot to connect the camera with SmartConnect. To activate the hotspot:

1. Press the **Display Backlight** button on the camera.



Two ascending tones sound (depending on the alert configuration settings).

2. Connect the SmartConnect app to the VISTA WiFi or VISTA XLT hotspot within two minutes or the hotspot deactivates.

Two descending tones sound when the hotspot deactivates.



**Important!** Start the hotspot before starting the SmartConnect application.

---

## No cameras found

If no camera is found, follow the instructions on the screen.

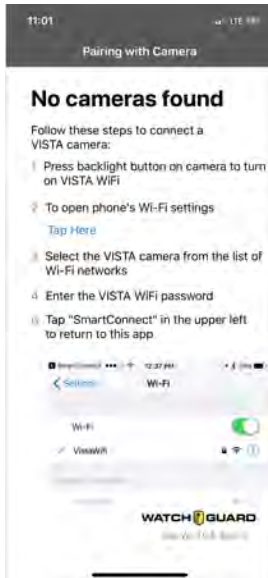

## Controlling battery usage

How you set your hotspot settings gives you control over your battery usage and hotspot connection time. You can choose one of the settings shown here for your VISTA WiFi or VISTA XLT.

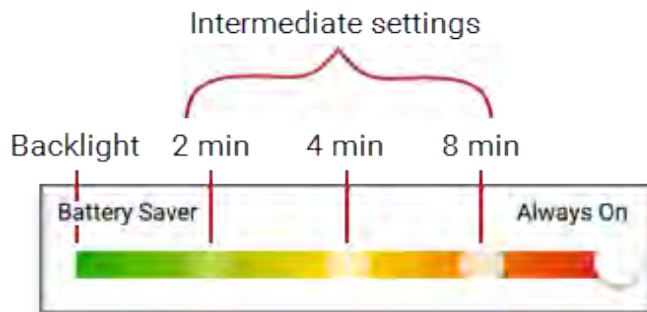

**Battery Saver** uses the least battery power. Push the **Display Backlight** button on the camera to start the hotspot.

- If the Wi-Fi client does not attach, the hotspot waits for 2 minutes, then shuts down.
- If a Wi-Fi client attaches, the hotspot stays on for another 2 minutes waiting for the SmartConnect app to connect. If the app does not connect, the hotspot shuts down.

**Intermediate settings—2, 4, or 8 minutes.** These settings activate the hotspot on a record-stop, waiting for initial app connect.

- If the app does not connect within the time frame based on your slider position, the hotspot shuts down.
- The camera is not allowed to sleep during the wait period.

**Always On** uses the most battery power but activates when the camera is off the dock and not in sleep mode.

- On undock, boot, or reboot there is a 10 second wait to activate the hotspot.
- When coming out of sleep mode, the hotspot restarts immediately.

## Disconnecting SmartConnect

### *Standard disconnect*

The below scenario describes a standard disconnect which happens when the app is:

- Closed
- Put in the background
- The phone goes to sleep

After the app connects, the hotspot remains on for as long as the app is connected. The camera cannot enter sleep mode, even if configured to do so. The hotspot waits a full minute to shut down after the app is disconnected. This lets you get back into the app quickly without having to re-establish the Wi-Fi connection.

### *Nonstandard disconnect*

The below scenario describes a nonstandard disconnect such as:

- You walk out of range
- The Wi-Fi is turned off
- The app disconnects on its own

If no explicit disconnect occurs, the camera continues to search for activity for 1 minute. After this time, VISTA WiFi or VISTA XLT starts a 1-minute grace period and then stops the hotspot. This gives you 2 minutes to reconnect if a nonstandard disconnect occurs.

## Connecting to VISTA SmartConnect

---

At VISTA WiFi or VISTA XLT checkout, your Evidence Library software assigns you an SSID and you create a password. You enter this SSID/password combination in the Wi-Fi settings on your smartphone to connect the SmartConnect app with the camera. For information on getting your SSID/password combination at VISTA WiFi or VISTA XLT checkout, see your Evidence Library software documentation.

You only enter the SSID and password **the first time you connect** VISTA WiFi or VISTA XLT with the SmartConnect application.



**Important!** *If you change the password associated with your SSID, you must use the steps to connect camera with SmartConnect for the first time (below).*

---

### Connecting VISTA WiFi or VISTA XLT to SmartConnect for the first time

Before you start the connection process, you need:

- Checked-out VISTA WiFi or VISTA XLT, powered ON
- Smartphone, powered ON
- The SSID and password that your Evidence Library software assigned to you



**Important!** *You must turn on the hotspot before starting the application ([page 90](#)).*

---

To connect VISTA WiFi or VISTA XLT with VISTA SmartConnect for the first time:

1. Download **VISTA SmartConnect** to your smartphone from the app Store.



**Tip:** For best results, do not open the VISTA SmartConnect app until instructed to open it.

---

2. Navigate to **Settings >Wi-Fi > Other**.
3. Enter the **SSID** that Evidence Library assigned to you at checkout.
4. Select **WPA2** as your security level.



**Note:** If you have a choice between WPA2 Personal and WPA2 Enterprise, select WPA2 Personal.

---

5. Go back to **Other** network screen.
6. Enter the **Password** you created when you checked out your VISTA WiFi camera. Do not press the **Join** button.
7. Press the **Display Backlight** button on your VISTA WiFi to turn on the hotspot.  
Two ascending tones sound (depending on the VISTA WiFi alert configuration settings).
8. Press **Join** on the top right.
9. Press the **SmartConnect** app icon.

The app presents the **Searching for cameras** screen while trying to find a camera to connect to.

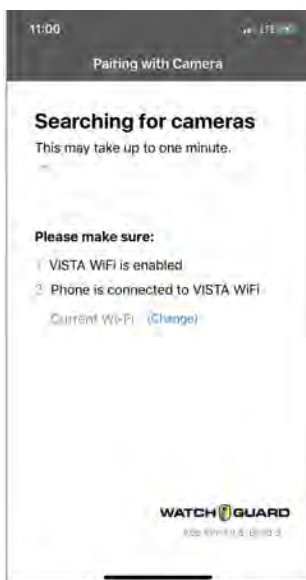

10. Press the **Display Backlight** button to pair the app with the camera.



The **Recorded Events** screen opens after pairing is complete and shows a list of events available on your VISTA WiFi or VISTA XLT.



## Connecting VISTA WiFi or VISTA XLT to SmartConnect after the first time

To connect VISTA WiFi or VISTA XLT with VISTA SmartConnect after the first time:

1. Press the camera **Display Backlight** button to activate the hotspot. (page 89)
2. Open the VISTA SmartConnect app icon. 

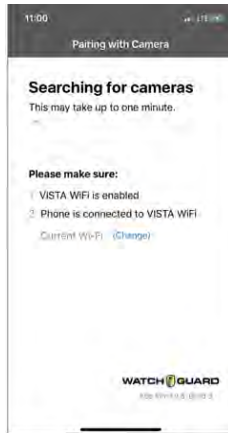

The **Pairing with Camera** screen opens while the app is searching for the camera to connect with. After it finds the camera, the **Recorded Events** screen opens showing a list of events on your camera.

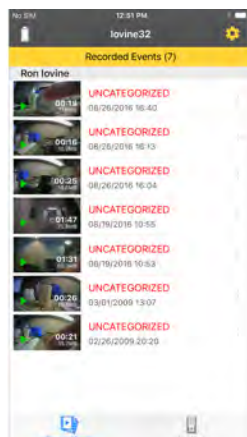

## Reviewing VISTA WiFi or VISTA XLT Recorded Events

You can review recorded event video from your VISTA WiFi or VISTA XLT camera on the smartphone application.

After you connect and the event screen appears:

- Touch the thumbnail for the video event you want to review.

The event starts playing back.

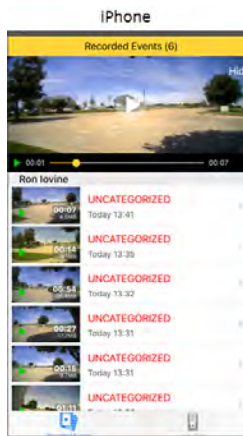

## Capturing snapshots

If snapshots are enabled for SmartConnect in your Evidence Library software:

- Touch the camera icon  to save a snapshot of the current frame to the phone photo gallery.

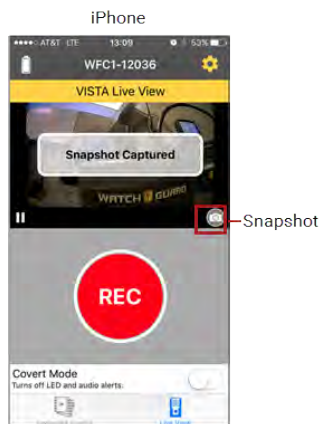



**Warning!** Capturing snapshots of video from the VISTA SmartConnect app and saving them to the smartphone photo gallery can make the phone part of the chain of evidence.

If you did not accept saving your snapshot files when you first connected to SmartConnect, the app will ask at this point. If you select **Deny**, you will not be able to save snapshots.

## Categorizing Recorded Events

You can use the VISTA SmartConnect smartphone application to categorize a recorded event on your VISTA camera.

After the **Recorded Events** screen opens follow the steps for your smart phone.

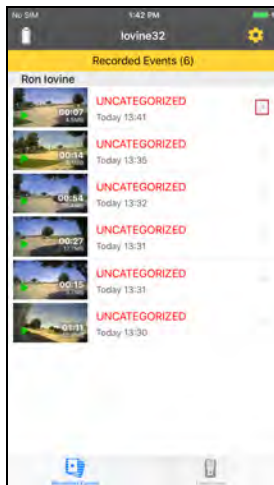

To categorize an event:

1. Touch the arrow > for the event that you want to categorize.

The **Edit Event Tags** screen opens for the event you selected.



2. Touch the arrow > for the **Category** event tag.

The **Set Category** screen opens.

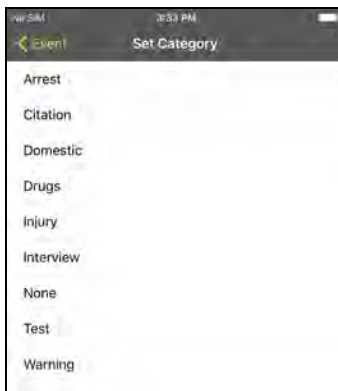

3. Touch the category you want to apply to the recorded event.



**Note:** If there are secondary event tags assigned to your VISTA WiFi or VISTA XLT configuration, those tags appear after you select the category.

---

# Live Streaming

You can live stream the view from your VISTA WiFi or VISTA XLT camera with the VISTA SmartConnect smartphone application.

1. Connect your VISTA WiFi or VISTA XLT to VISTA SmartConnect on your smartphone. (**page 94**)

The **Recorded Events** screen opens.

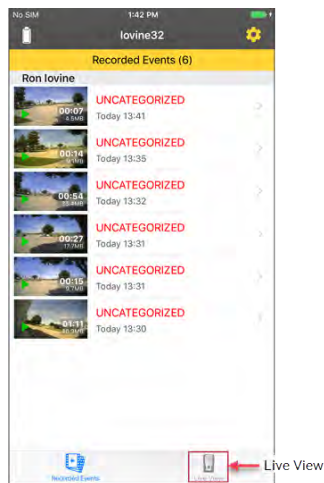

2. Touch **Live View**.

The **VISTA Live View** screen opens showing an inactive player.

3. Touch the play icon to start live streaming from the camera.



## Covert Mode

Enable **Covert Mode** on the **VISTA Live View** screen.

- Touch or slide the **Covert Mode** switch until the background changes color.

## Starting and Stopping Recorded Events

---

You can start or stop a recorded event on your VISTA WiFi or VISTA XLT camera with the smartphone application:

1. Connect your VISTA WiFi or VISTA XLT to VISTA SmartConnect on your smartphone. (**page 94**)

The **Recorded Events** screen opens.

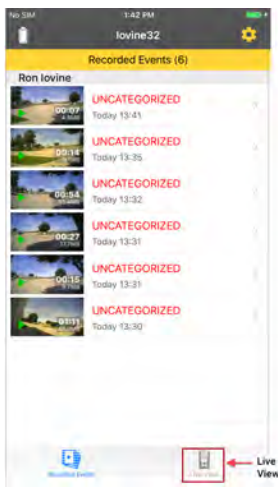

2. Touch the **Live View** icon.

The **VISTA Live View** screen opens.

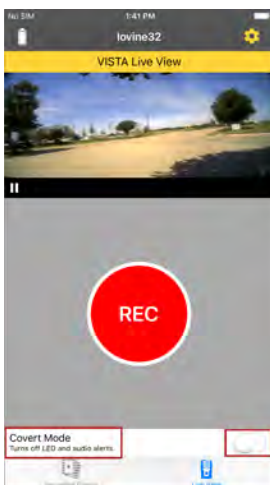

3. Touch **REC** to start recording an event.

The camera starts recording. SmartConnect shows that the camera is recording with the red bar at the top of the app on the iPhone.



4. Touch **STOP** to stop recording an event.

## SmartConnect Settings

Touch the **Settings** icon  to access the SmartConnect **Camera Settings** screens.

### Camera Settings

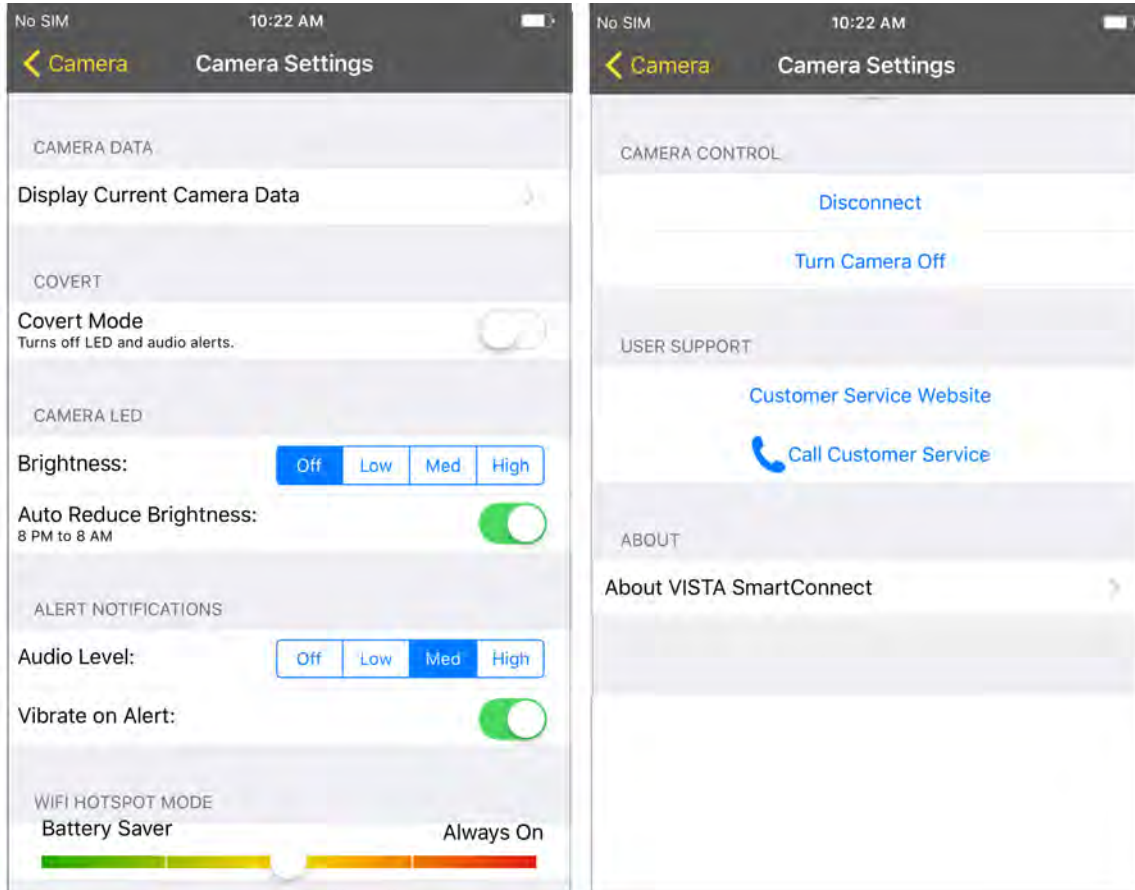



## Camera Data

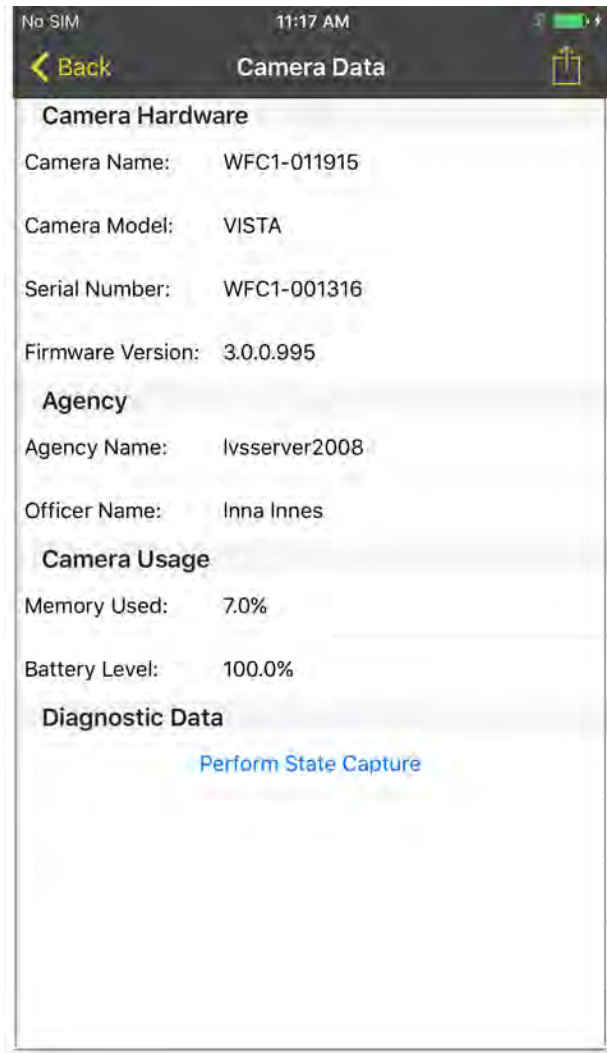

You can request that your VISTA WiFi or VISTA XLT perform a state capture and save it for use by WatchGuard Technical Services.

This page intentionally left blank.

## Appendix B: Using the Quick Connect Mobile Charger

*In this section...*

- Quick Connect Mobile Charger overview (**page 108**)
- Mobile Charger parts (**page 108**)
- Using the Mobile Charger (**page 111**)



**Warning!** *The Quick Connect Mobile Charger uses magnets to connect to the cable. Do not wear the Mobile Charger near sensitive medical equipment or implants such as pacemakers or other magnetically programmable medical devices.*

---

### FCC Rules compliance

This device complies with Part 15 of the FCC Rules. Operation is subject to the following two conditions:

1. This device may not cause harmful interference.
2. This device must accept any interference received, including interference that may cause undesired operation.

## Overview

---

The VISTA Quick Connect Mobile Charger lets recording and charging occur at the same time. Information screens remain the same as if the VISTA Body Camera is undocked and not charging. You do not have to remove your camera to charge it.

The Mobile Charger works with extended-capacity VISTA and VISTA WiFi running version 3.0 or higher. It is NOT supported for standard-capacity VISTA or VISTA XLT.

The Mobile Charger lets you extend the working time of your VISTA Body Camera when a 12-hour charge is not enough. Connecting or disconnecting the Mobile Charger does not affect the running mode of the VISTA Body Camera. Covert mode and the recording state are preserved.



## Mobile Charger Parts

---

The Quick Connect Mobile Charger consists of the base and the charging cable that are connected with magnets.



**Warning!** The Quick Connect Mobile Charger uses magnets to connect to the cable. Do not wear the Mobile Charger near sensitive medical equipment or implants such as pacemakers or other magnetically programmable medical devices.

---



## Mobile Charger base

The VISTA Body Camera slips into the base with a click. Do not tilt the camera when inserting it. Ensure that you insert the camera with the front of the camera facing the same way as the WatchGuard logo on the front of the mobile charger.

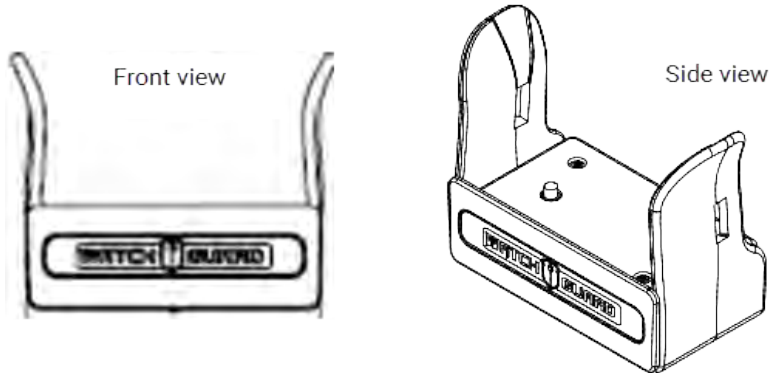

To remove the VISTA Body Camera from the Mobile Charger:

1. Gently pull one wing of the charger base outward from the camera.
2. Rock or tilt the Mobile Charger base away from the camera.

## Mobile Charger cable

The 12V cigarette-lighter plug for the mobile charger has a 3-amp fuse built in. This fuse may or may not be higher than what your vehicle electrical panel is configured with. The cable has no limiting mechanism so it will draw the maximum current the supply can provide if shorted.

This can cause the fuse to blow in the lighter plug of the cable or in the vehicle electrical distribution box. If this happens:

1. Check your vehicle distribution box.
  - a. If the fuses are 3A or smaller, replace these before replacing the Mobile Charger cable fuse.
  - b. If the fuses are greater than 3A, replace the Mobile Charger cable fuse.  
 WatchGuard recommends the Littelfuse 312003P (part number WGP02649). This is a 250 V, 3A, Fast Acting Fuse. The fuse size is 3AG.
2. Replace the fuse in the Mobile Charger cigarette-lighter plug.
  - a. Grasp the lighter plug.
  - b. Unscrew the contact end.  
 The fuse comes out when you fully unscrew the end and pull it out.
  - c. Replace the existing fuse with a 3A fuse and reinsert it into the lighter plug.

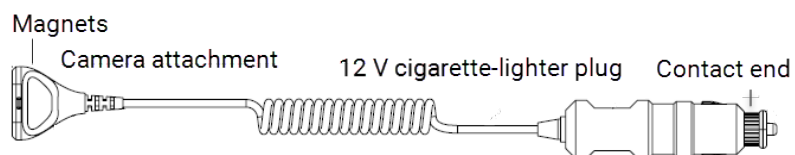



**Note:** WatchGuard supports the US-type 12 V cigarette-lighter plug.

### *Cable connection end*

The cable has magnets that align with the bottom of the Quick Connect Mobile Charger. They are strong enough that they will not fall off of the base if you are moving around in the car or a short distance from the car. They pull away easily from the base when you want to exit the car. The charger works with the cable in any attachment orientation.

### *12 V cigarette-lighter plug*

Some cigarette-lighter receptacles do not hold the plug tightly. You can use the clip (part number WGP760-100) and screw (part number WGP635-002) to secure the cable to the console as shown in the graphic. This prevents the cigarette-lighter plug from pulling out of the receptacle when you pull on the cable. The clip and screw are shipped with the Quick Connect Mobile Charger.

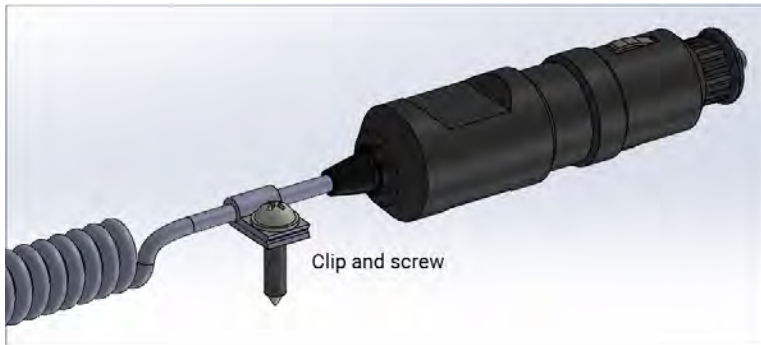

## Using the Mobile Charger

The Mobile Charger charges itself through the vehicle cigarette lighter. Plug the cable into the cigarette lighter receptacle, then attach the other end to the Mobile Charger.



**Note:** When turned off, some vehicles continue to supply 12 V power to the cigarette-lighter receptacle. To avoid a possible dead battery, disconnect the charger cable from the Mobile Charger.

When the Mobile Charger is connected, the VISTA Body Camera does not indicate on the display or in the logs that the camera is docked. The camera successfully records, stops recording, and acts according to its group recording configuration when it is connected to the Mobile Charger.

The camera has different notifications for different tasks, as shown in the table.

Actions	Mode	Notification
<b>Connecting to</b> Mobile Charger	Non-Covert	- Ascending tones with vibration (depends on agency configuration) - Battery icon updates - Does not affect running mode
	Covert	- Vibration (depends on agency configuration) - Battery icon updates - Does not affect running mode
<b>Disconnecting from</b> Mobile Charger	Non-Covert	- Descending tones with vibration (depends on agency configuration) - Battery icon updates
	Covert	- Vibration (depends on agency configuration) - Battery icon updates
<b>Charging in Mobile</b> Charger		- Crawling battery icon then full battery icon - CHARGE COMPLETE shows when finished - Tone when complete (depends on agency configuration) - Solid green LED - Does not indicate that it is connected

Although the camera backlight does not illuminate, you can turn it on by pushing the **Display Backlight** button on the side of the camera. It also comes on when you start an event.

This page intentionally left blank.



## Appendix C: Upgrading VISTA, VISTA WiFi, and VISTA-Related Devices

This appendix contains information and instructions for:

- Upgrades to VISTA and VISTA WiFi that are different in some way from the standard upgrade process (**page 40**)
- Upgrades to other devices related to VISTA or VISTA WiFi



**Note:** *The upgrade instructions included in this appendix are in release-date order. Each set of instructions stands on its own.*

---

Upgrade instructions included in this appendix:

- Upgrading VISTA or VISTA WiFi to firmware version 2.2.0 (**page 114**)
- Upgrading the VISTA WiFi Base and the Smart Power Switch (**page 115**)
- Upgrading VISTA or VISTA WiFi from a pre-v2.0.2 firmware version (**page 116**)

## Upgrading VISTA or VISTA WiFi to Firmware Version 2.2.0

---



**Warning!** VISTA and VISTA WiFi do NOT support downgrading from firmware version 2.2.0 and above to a firmware version prior to 2.2.0.

---

To upgrade VISTA or VISTA WiFi to firmware version 2.2.0:

1. Dock the camera in a base or Transfer Station connected to your Evidence Library software.  
The Evidence Library software automatically detects that the camera is docked and that its firmware needs to be updated.
2. Using Evidence Library software, ensure the version 2.2.0 firmware is pushed to the camera.



**Note:** Evidence Library software can be set up to push firmware manually or automatically.

---

The version 2.2.0 firmware is staged on the camera.

3. The **next time** you dock it, the VISTA or VISTA WiFi camera upgrades to the staged firmware version 2.2.0.
4. WAIT while the camera upgrades its firmware.

While the camera is upgrading, the LCD Display shows **UPDATING DO NOT INTERRUPT**.



**Warning!** DO NOT REMOVE the camera from the dock while it upgrades its firmware. Removing the camera from the dock while it upgrades can cause the camera to stop functioning.

---

When it finishes upgrading, the camera sounds the camera ready alert (depending on your alert notification selections).

5. The **next time** you undock the camera, it reboots itself.  
While the camera is restarting, the LCD Display shows **BOOTING**.
6. When the camera finishes rebooting, you can use it normally.



**Tip:** After you have completed these upgrade instructions, if VISTA or VISTA WiFi's LCD Display shows **Err 30** or **Err 120**, contact WatchGuard Customer Service.

---

## Upgrading the VISTA WiFi Base and the Smart Power Switch

---

When upgrades are available for the VISTA WiFi Base and the Smart Power Switch, the upgrades are included with the VISTA Body Camera upgrade. Once the camera has been upgraded, the next time it is docked in the WiFi Base, it makes the base and switch upgrade packages available.

For information on upgrading the VISTA Body Camera, see *Upgrading firmware* on **page 40**.



**Note:** Typically, WatchGuard releases upgrades for the camera, the WiFi Base, and the Smart Power Switch at the same time.

---

To upgrade the VISTA WiFi Base and the Smart Power Switch:

1. Dock the upgraded camera in the WiFi Base and allow it to pair with the base.  
The base's left LED blinks green multiple times when the camera and base are paired.
2. WAIT while the camera stages any video it has stored.  
When the camera has finished staging its video, it blinks its red LED multiple times.



**Note:** The amount of time the camera needs to stage its video depends on how much video is stored on it.

---

3. After the camera has finished staging video, WAIT about 4 minutes for the base to download and stage its upgrade package, then download and stage the switch's upgrade package.

**As the base begins to download and stage its own upgrade package**, the base's left LED blinks between green and yellow very quickly.

**Once the base has fully downloaded and staged its own package**, it begins downloading and staging the package for the switch. At this point, the base's left LED blinks between green and yellow more slowly.

**Once the switch's package is fully downloaded and staged**, the base's left LED turns solid green.

4. Once the base's left LED turns solid green, you can use the camera normally.



**Important!** Make sure you maintain power to the system while the upgrades are being downloaded and staged.

---

The next time the WiFi Base and the Smart Power Switch are restarted, their staged upgrades are applied. New functionality included in the upgrades only becomes available once the upgrades are applied.

## Upgrading VISTA or VISTA WiFi from a Pre-v2.0.2 Firmware Version

---



**Important!** If you are upgrading VISTA or VISTA WiFi to firmware version 2.2.0, see *Upgrading VISTA or VISTA WiFi to Firmware Version 2.2.0* on **page 114**.

---

If you want to upgrade VISTA or VISTA WiFi firmware in the VISTA Transfer Station, and are upgrading from a firmware version prior to version 2.0.2:

1. Dock the camera in the Transfer Station and allow the camera to download the upgrade package from your Evidence Library server.
2. WAIT until the amber (center) LED on the Transfer Station STOPS flashing.



**Important!** Undocking VISTA or VISTA WiFi before the amber light stops flashing can cause issues with the camera upgrade process.

---

3. Undock the camera and leave it undocked and powered ON.
4. WAIT a full 3 minutes.



**Warning!** It is critical that you **DO NOT** redock or power down the camera for a full 3 minutes after undocking. Redocking or powering the camera down before a full 3 minutes have passed can cause the camera to stop working completely.

---

5. After you have waited a full 3 minutes, you can use VISTA or VISTA WiFi normally.



**Note:** After a full 3 minutes, you can also redock the camera in the Transfer station to finish the upgrade process.

---



**Tip:** After you have completed these instructions, if the camera shows **Err 120**, contact WatchGuard Customer Service.

---

## Appendix D: VISTA Transfer Station Setup

*In this section...*

- Setting up the VISTA Transfer Station hardware (**page 119**)
- Configuring the VISTA Transfer Station for use with Evidence Library software (**page 121**)

## Overview

---

The VISTA Transfer Station allows your agency to upload video evidence to its WatchGuard Evidence Library software from multiple VISTA Body Cameras simultaneously. Each VISTA Transfer Station has eight slots for VISTA Body Cameras. You can connect multiple Transfer Stations to one instance of Evidence Library software, but you must set up and configure each Transfer Station separately.



**Important!** To use the VISTA Transfer Station to upload video to your system, your VISTA Body Cameras must be at version 1.1 or above, and your Evidence Library software must be Evidence Library 4 Web.

---

When you set up the VISTA Transfer Station, you connect it to power and to the network containing your agency's instance of Evidence Library software. To set up the VISTA Transfer Station:

1. Set up the Transfer Station hardware. (**page 119**)
2. Configure the Transfer Station so the VISTA Body Cameras docked in it will upload to your Evidence Library software. (**page 121**)



**Important!** To set up the VISTA Transfer Station, WatchGuard recommends that you be an IT administrator or have your IT administrator on-call. Although this setup guide can be used by anyone, it assumes an understanding of some IT concepts that could make following the process difficult for a non-IT administrator.

---

## VISTA Transfer Station Hardware

When you set up the VISTA Transfer Station hardware, you connect the power cable and the Ethernet cable to the Transfer Station. You can add labels to the Transfer Station slots as well, if desired.



**Note:** WatchGuard offers rack options for mounting multiple Transfer Stations in the same location. For more information, contact your WatchGuard representative.

Included with the VISTA Transfer Station :

- Power cable
- Ethernet cable
- Sheet of **Station ID/Slot #** labels

### Setting up the hardware

To set up the VISTA Transfer Station hardware:

1. If desired, use the provided **Station ID/Slot #** stickers to label the Transfer Station slots.



**Tip:** The provided labels assume an alphabetic **Station ID**, for example, **B**, then slot numbers 1 through 8; so, in this example, for the Transfer Station with the **Station ID** of **B**, you use the labels **B1, B2, B3, B4, B5, B6, B7, and B8**.

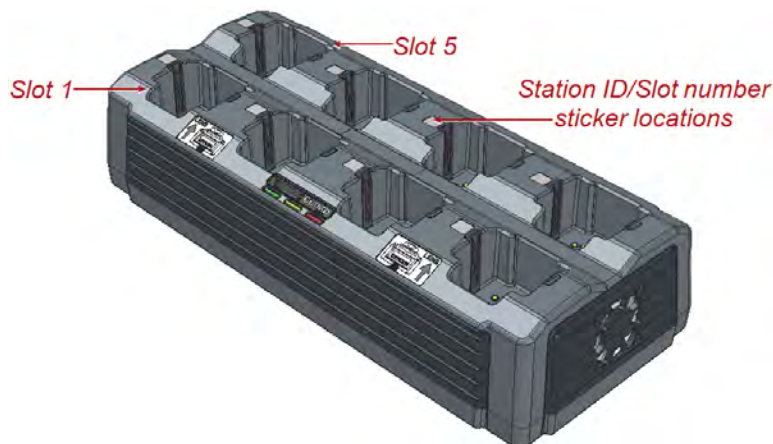



**Important!** You must enter the **Station ID** that you selected when you configure the Transfer Station for use with Evidence Library software (see [page 125](#)). The **Station ID** combined with the **Location** (also entered during Transfer Station configuration) indicate a specific Transfer Station to Evidence Library.

2. Connect the power cable to the power connector on the bottom of the Transfer Station, plug the power cable into an electrical outlet, then power the Transfer Station ON.

*VISTA Transfer Station bottom*

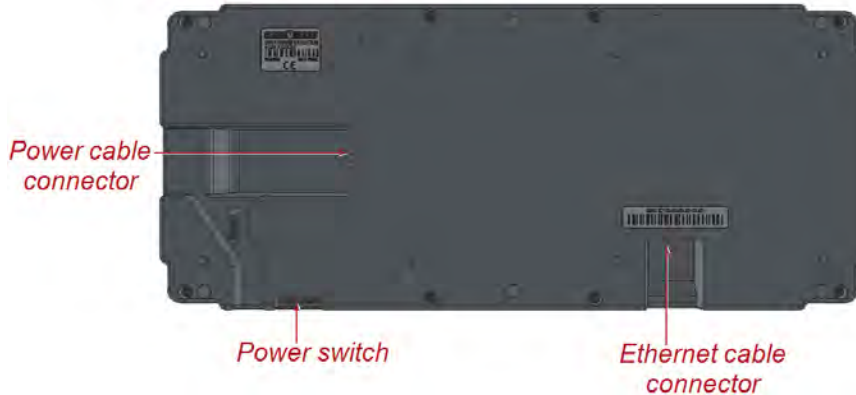

3. Connect the Ethernet cable to the Ethernet connector on the back of the Transfer Station.

*VISTA Transfer Station back*



4. Connect the other end of the Ethernet cable to a computer that you have set up to access the Transfer Station's factory default configuration web page.



**Tip:** You access the default configuration web page using the Transfer Station factory default IP address: 192.168.2.20. The computer you use must have access to this network.

To continue setting up the VISTA Transfer Station, follow the instructions on [page 125](#) to configure the Transfer Station to work with your Evidence Library software.



## VISTA Transfer Station Configuration

You configure each VISTA Transfer Station individually using a web page specific to that Transfer Station. When you configure the VISTA Transfer Station, you configure:

- **Transfer Station Settings** (below)
- **VISTA Settings** (page 122)

The configuration web page also allows you to perform some non-configuration administrative functions for the Transfer Station (page 123).

You access the VISTA Transfer Station's configuration web page using your web browser.

For step-by-step instructions how to configure a VISTA Transfer Station, see *Configuring the Transfer Station* on page 125.

### Transfer Station Settings

When you configure the **Transfer Station Settings**, you assign the Transfer Station a **Location** name and **Station ID**. You either assign it a **Static IP Address** or let your **DHCP** server assign its IP address. You can set a date and time for the Transfer Station as well, if desired.



**Note:** WatchGuard recommends that you set up a pool of static IP addresses that you assign to your VISTA Transfer Stations.

The **Location** and **Station ID** (along with the **Slot #** from the **VISTA Settings** section) are used by the Evidence Library software to indicate to an officer which VISTA Body Camera he is checking out.



**Note:** The **Location** and **Station ID** fields each have a 32-character limit.

### Static IP

Building 415 : B Logout

Current Transfer Station Configuration

TRANSFER STATION SETTINGS

Location	Station ID	IP Config
Building 415	B	Static
IP Address	Subnet Mask	Gateway
10.1.10.120	255.0.0.0	10.0.0.1

Date/Time Settings

[Save Settings](#)

### DHCP and Date/Time Settings

Building 415 : B Logout

TRANSFER STATION SETTINGS

Location: Building 415    Station ID: B    IP Config: DHCP

Date/Time Settings

System Date: Month: Oct, Day: 13, Year: 15    System Time: Hours: 16, Minutes: 07, Seconds: 15

Save Settings

### VISTA Settings

When you configure the **VISTA Settings**, you set the **Upload Server IP** address and **Port**, indicating the Evidence Library server where your VISTA Body Cameras should upload video evidence.



**Tip:** The upload server for Evidence Library can also be called the Wireless Import Service.

You either let your **DHCP** server assign IP addresses to the VISTA Body Camera slots or you assign a **Static IP Address** to each slot individually.



**Note:** WatchGuard recommends that you let your DHCP server assign the slot IP addresses.

### DHCP

VISTA SETTINGS

Upload Server IP: 10.1.0.78    Upload Server Port: 5001    VISTA IP Config: DHCP

Save VISTA Settings

*Static IP*

**VISTA SETTINGS**

Upload Server IP 10.1.0.78	Upload Server Port 5001	VISTA IP Config Static
Subnet Mask 255.0.0.0	Gateway 10.0.0.1	

<p><b>SLOT 1</b></p> <p>IP Address 10.1.10.121</p>	<p><b>SLOT 2</b></p> <p>IP Address 10.1.10.122</p>
<p><b>SLOT 3</b></p> <p>IP Address 10.1.10.123</p>	<p><b>SLOT 4</b></p> <p>IP Address 10.1.10.124</p>
<p><b>SLOT 5</b></p> <p>IP Address 10.1.10.125</p>	<p><b>SLOT 6</b></p> <p>IP Address 10.1.10.126</p>
<p><b>SLOT 7</b></p> <p>IP Address 10.1.10.127</p>	<p><b>SLOT 8</b></p> <p>IP Address 10.1.10.128</p>

Save VISTA Settings

*Transfer Station administrative functions*

You can perform a number of administrative tasks for the Transfer Station from the configuration page, including:

- Upgrading the Transfer Station software or firmware (below)
- Changing the login credentials for the Transfer Station configuration page (**page 124**)
- Disabling the configuration page (**page 124**)
- Restarting the Transfer Station (**page 125**)

*Upgrading the Transfer Station software or firmware*

- Click the **Choose File** button for the upgrade you want to perform, navigate to and select the appropriate software (.hex file) or firmware (.bit file) upgrade file, then click the appropriate **Upgrade** button.

<p style="font-size: small; margin: 0;">TRANSFER STATION SOFTWARE UPGRADE</p> <div style="border: 1px solid #ccc; padding: 2px; margin: 5px 0;"> <span style="background-color: #ccc; border: 1px solid #ccc; padding: 2px 5px;">Choose File</span> No file chosen         </div> <div style="text-align: center; margin-top: 5px;"> <span style="background-color: #4CAF50; color: white; padding: 5px 15px; border-radius: 3px;">Upgrade Software</span> </div>	<p style="font-size: small; margin: 0;">TRANSFER STATION FIRMWARE UPGRADE</p> <div style="border: 1px solid #ccc; padding: 2px; margin: 5px 0;"> <span style="background-color: #ccc; border: 1px solid #ccc; padding: 2px 5px;">Choose File</span> No file chosen         </div> <div style="text-align: center; margin-top: 5px;"> <span style="background-color: #4CAF50; color: white; padding: 5px 15px; border-radius: 3px;">Upgrade Firmware</span> </div>
---	---

---

**Important!** After you have upgraded the Transfer Station, you must power the Transfer Station off and then on again for the cameras to recognize the upgrade.

---

### Changing the login credentials for the Transfer Station configuration page

The first time you log in to the Transfer Station configuration page, use the default user name, **Admin**, and password, **V1\$T@xfr**.



**Note:** WatchGuard recommends that you change the user name and password from the default values the first time you log in to the Transfer Station configuration page.

A screenshot of a web form titled "CHANGE USERNAME / PASSWORD". It contains two input fields: "Username" with the text "Admin" and "Password" with masked characters "\*\*\*\*\*". Below the fields is a green button labeled "Save Changes".

To change the **Username** and **Password**:

- Enter the new credentials in the fields, then click **Save Changes**.

The system logs you out of the Transfer Station configuration page and asks you to log back in using the new credentials.

### Disabling the configuration page

The **Disable** feature can function as another level of security. Disabling the configuration page (web server) after you have finished configuring the Transfer Station prevents others from accessing the configuration page to make unauthorized changes.

When you disable the configuration page, however, you also prevent authorized administrators from making changes as needed.



**Warning!** Disabling the configuration page prevents anyone, including authorized administrators, from making changes to the VISTA Transfer Station configuration.

To disable the current VISTA Transfer Station's configuration page (web server):

- Click **Disable**.

A screenshot of a warning dialog box. The text reads: "Click Disable to disable the web server for the current VISTA Transfer Station. Once its web server is disabled, the Transfer Station cannot be configured unless it is reset back to factory default. To reset the Transfer Station to factory default, press the Reset button on the bottom of the Transfer Station." Below the text is a green button labeled "Disable".

Once you disable the configuration page for the current Transfer Station, you cannot change any configuration settings or configure the current Transfer Station at all UNLESS you reset the Transfer Station to factory default. If you reset a Transfer Station back to factory default, all current settings are lost and you must start the configuration process again from the beginning.



**Warning!** Resetting a VISTA Transfer Station to factory default reverts any values you set on the Transfer Station's configuration page back to the default values.

To reset the VISTA Transfer Station back to factory default:

- Using a pin or a paper clip, press and hold (for at least 7 seconds) the **Reset** button on the bottom of the Transfer Station.



**Note:** The **Reset** button is located near the power cable connector on the bottom of the Transfer Station.

### Restarting the Transfer Station

The **Restart** feature functions as a soft restart of the Transfer Station. To perform a soft restart of the VISTA Transfer Station:

- Click **Restart**.

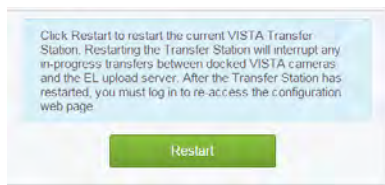

## Configuring the Transfer Station

To configure a VISTA Transfer Station:

1. Set up a computer to access a VISTA Transfer Station's factory default configuration web page at its default IP address, 192.168.2.20.
2. If not already done, connect the Ethernet cable from the Transfer Station to the computer.
3. Open your web browser, enter the Transfer Station default IP address in the browser address field, and press **Enter**.

The **Secure Sign In** screen opens for the connected Transfer Station.

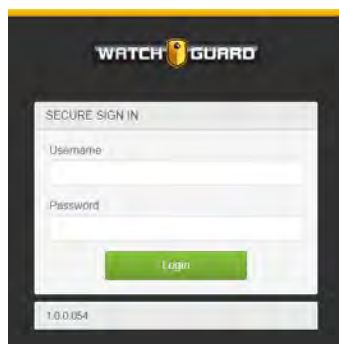

4. Enter the default **Username** and **Password (Admin, V1\$T@xfr)**, then click **Login**.



**Note:** WatchGuard recommends that you change the default **Username** and **Password** the first time you log in. For more information, see *Transfer Station administrative functions* on **page 123**.

The **Transfer Station Configuration** page opens showing the default settings.

5. In the **Transfer Station Settings** section, enter the **Location** (32-character limit) where the current Transfer Station will be used, for example, **Building 415**.

For more information about the **Transfer Station Settings** section, see *Transfer Station Settings* on **page 121**.

6. Enter the **Station ID** (32-character limit) that identifies the current Transfer Station, for example, **B**.



**Note:** WatchGuard provides labels that assume an alphabetic **Station ID**, for example, **B**, combined with slot numbers 1 through 8.

7. Select the **IP Config** type you want to assign to the Transfer Station, either **Static** or **DHCP**.



**Note:** WatchGuard recommends the **Static IP Config** type for the Transfer Station.

8. If you selected the **Static IP Config** type, enter the static **IP Address**, the **Subnet Mask**, and the **Gateway** that you want to assign to the current Transfer Station.

If you selected the **DHCP IP Config** type, go to the next step.

9. If desired, click **Date/Time Settings** and set the date and time local to the Transfer Station.
10. Click **Save Settings**.

The system logs you out. The default configuration web page is no longer valid for the connected Transfer Station because the Transfer Station IP address has changed.

11. Enter the new IP address for the connected Transfer Station in your browser address field, then press **Enter**.

The configuration page opens showing the information you just entered.

12. In the **VISTA Settings** section, enter the **Upload Server IP** address.

For more information about the **VISTA Settings** section, see *VISTA Settings* on **page 122**.



**Note:** The upload server is the Evidence Library location where the VISTA Body Cameras will upload their video evidence. The upload server for Evidence Library can also be called the Wireless Import Service.

13. Verify that the **Upload Server Port** is set to **5001**.



**Warning!** Changing the **Upload Server Port** to something other than **5001** can cause the VISTA Transfer Station to stop working. If you have questions about the assigned port, contact WatchGuard Technical Services.

14. Select the **VISTA IP Config** type you want to assign to the camera slots, either **Static** or **DHCP**.



**Note:** WatchGuard recommends that you let your DHCP server assign the slot IP addresses.

15. If you selected the **DHCP VISTA IP Config** type, go to the next step.

If you selected the **Static VISTA IP Config** type, enter the camera slot **Subnet Mask** and **Gateway**, then an individual static **IP Address** for each of the eight slots.

16. Click **Save VISTA Settings**.

When the Transfer Station has made a successful connection with the upload server, the amber (center) LED lights up.

Repeat this procedure to set up each VISTA Transfer Station you want to use in your WatchGuard system.

This page intentionally left blank.



# Index

## 4

4RE DVR, recording groups, 82

## A

aborting status sequence, 50, 54

access point, 50, 54, 84-85, 90

alerts, 57

battery low

VISTA, 60

XLT, 60

Mobile Charger, 111

periodic, 77

storage full, 58

amber LED

Transfer Station, 65

WiFi Base, 67

assigning a configuration, 35

associating with recording groups, 44, 81

audio

always on, 73

muting, 28, 50, 54

pre-event, 71

Record After the Fact, 73

auto off, 75, 82, 84

automatic

event categorization, 29

event start and stop, 26, 46

## B

base connectors

Transfer Station, 65

USB Base, 64

WiFi Base, 68

bases

Mobile Charger, 109

Transfer Station, 65

setting up, 66, 118

USB, 64

setting up, 64

WiFi, 66

setting up, 68

battery, 59

alert

VISTA, 60

XLT, 60

charging, 42, 64-66

extended capacity, 59

saving, 70, 74-76

standard capacity, 59

status

VISTA, 51

XLT, 54

XLT capacity, 60

Battery Charge icon

VISTA, 59

XLT, 60

battery low alert

VISTA, 60

XLT, 60

belt clip

VISTA, 15

XLT, 20

body-mounted camera sensor, 52

wearing, 22-23

buttons

display light, 28-29

VISTA, 50

XLT, 54

power, 24

VISTA, 49

XLT, 53

record, 26

VISTA, 50

XLT, 53

## C

cables

Mobile Charger, 109

Transfer Station, 119

USB Base, 64

WiFi Base, 68

camera components

battery, 59

buttons

VISTA, 49

XLT, 53

display

VISTA, 50

XLT, 54

GPS, 62

## Index

- indicators, 57
  - lens
    - VISTA, 49
    - XLT, 52
  - microphone
    - VISTA, 49
    - XLT, 53
  - mounting latch, 63
  - sensor
    - VISTA, 49
    - XLT, 52
  - storage, 57
  - Wi-Fi, 61
  - camera sensor, XLT, 52
    - clip mount, 23
    - glasses mount, 21
    - magnetic mount, 22
  - canceling
    - maximum recording time warning, 50, 54, 76
    - sleep warning, 50, 54, 74
  - capacity
    - battery
      - VISTA, 59
      - XLT, 60
    - storage, 57-58
  - capturing evidence, 46
  - categorizing events, 27, 29
    - automatic, 29
    - group recording, 83
    - selecting categories, 29, 50, 54
    - SmartConnect, 29, 99
    - using 4RE, 83
    - VISTA, 51
    - XLT, 55
  - charge time, 42
    - VISTA, 59
    - XLT, 60
  - charging battery, 42
    - mobile, 108
  - chest mount, locking, 16
  - clearing storage, 39
  - clips, mounting
    - VISTA, 15
    - XLT camera sensor, 23
    - XLT DVR, 20
  - configuring
    - camera, 35
    - tones and vibrations, 57
    - Transfer Station, 121, 125
  - confirmations
    - powering off, 24
    - record stop, 27
  - connecting to SmartConnect
    - first time, 94
  - continuous video capture, 46, 72
  - Covert Mode, 77, 102
  - customizing the camera, 30, 35
- ## D
- date/time, 62
    - VISTA, 51
    - XLT, 54
  - DHCP-assigned, Transfer Station, 121-122
  - display
    - VISTA, 50
    - XLT, 54
  - Display Backlight button, 28-29
    - VISTA, 50
    - XLT, 54
  - Distributed Multi-Peer Recording, 80
  - DMD Display, 54
  - docking
    - associating with recording groups, 44
    - charging, 42
    - provisioning, 35
    - Transfer Station, 33, 65
    - upgrading firmware, 40
    - uploading events, 37
    - USB Base, 31, 64
    - WiFi Base, 34, 66
- ## E
- emptying storage, 39
  - Ethernet, cable connector, 65, 119
  - event categorizing, 27, 29
    - automatic, 29
    - group recording, 83
    - selecting categories, 29, 50, 54
    - SmartConnect, 29
    - using 4RE, 83
    - VISTA, 51
    - XLT, 55
  - evidence capture, 46
  - exiting sleep, 74
  - extended capacity battery, 59

**F**

firmware, upgrading, 40  
     camera, 40  
     Transfer Station, 123  
 forcing microphone on, 73  
 forcing power off, 25  
 fuse, Mobile Charger, 109

**G**

glasses mount, 21  
 GPS, 62  
     status  
       VISTA, 63  
       XLT, 55, 63  
 green LED  
     camera, 57  
     Transfer Station, 65  
     WiFi Base, 67  
 group recordings, 44, 85  
     moving out of range, 84, 86  
     VISTA WiFi behavior, 86  
     VISTA XLT behavior, 86

**H**

head-mounted camera sensor, 52  
     wearing, 21  
 holster, XLT DVR, 20  
 hotspot, 50, 54, 84-85, 90-91  
     status, XLT, 55  
 hub, USB, 31, 42, 59, 61, 64

**I**

importing events, 37  
 indicators  
     camera, 57  
     Transfer Station, 65  
     WiFi Base, 67

**L**

laptop, 85  
 latch, mounting, 63  
 LCD Display, 50  
 LEDs  
     camera, 57  
     Transfer Station, 65  
     WiFi Base, 67  
 lens  
     VISTA, 49  
     XLT, 52  
 live stream, 101  
 live streaming, SmartConnect, 101

location information, 62  
 locking chest mount, 16  
 LOW BASE message, 60  
 LOW BATT message, 60

**M**

magnetic mount  
     VISTA, 16  
     XLT camera sensor, 22  
 magnets, Mobile Charger, 108  
 manual event request, 72  
 maximum recording time, 76  
     canceling warning, 50, 54, 76  
     warning, 76

**MDC, 85****microphone**

    forcing on, 73  
     muting, 28  
     VISTA, 49  
     XLT, 53

**Mobile Charger, 108**

    alerts and notifications, 111  
     base, 109  
     cable, 109

**mounting latch, 63****mounts**

    belt clip  
       VISTA, 15  
       XLT, 20  
     clip, XLT, 23  
     holster, XLT DVR, 20  
     locking chest mount, 16  
     magnetic, XLT, 22  
     shirt clip, 15  
     VISTA, 15  
       other, 18  
     XLT, 19  
       body-mounted camera, 22  
       DVR, 20  
       head-mounted camera, 21

**muting audio, 28, 50, 54****N**

notifications, 57  
     battery low  
       VISTA, 60  
       XLT, 60  
     Mobile Charger, 111  
     periodic, 77  
     storage full, 58

## Index

### O

Oakley mount, 21

orange LED

Transfer Station, 65

WiFi Base, 67

out of range, recording groups, 86

### P

pairing, WiFi Base, 44, 83-84

password, SmartConnect, 94

periodic recording alerts, 77

power

cable connector

Transfer Station, 65

USB Base, 64

WiFi Base, 68

saving, 70, 74-76

Power button, 24

VISTA, 49

XLT, 53

power/data connector, 68

powering off, 24

automatically, 75

confirmation, 24

forcing, 25

powering on, 24

pre-event, 71

protected video, 46

provisioning, 35

### Q

Quick Connect, 108

### R

radio, 85

RATF, 39, 47, 72

status, XLT, 55

Record After the Fact, 39, 47, 72

Record Start/Stop button, 26

VISTA, 50

XLT, 53

record stop confirmation, 27

record time, 57

recorded events

alerts, 77

definition, 46

group recordings, 85

starting automatically, 26, 80, 82, 84

starting manually, 26

stopping automatically, 26, 76, 84

stopping manually, 27

uploading, 47

recording

alerts, 77

audio, 73

length

VISTA, 51

XLT, 54

status

VISTA, 51

XLT, 55

recording groups, 81

associating, 44

members, 81

4RE DVR, 82

Smart Power Switch, 82

VISTA WiFi, 84

VISTA XLT, 84

WiFi Base, 83

moving out of range, 86

red LED

camera, 57

Transfer Station, 65

WiFi Base, 67

review, 98

rotatable clip, 15

### S

saved storage total

VISTA, 51

XLT, 55

sensor

VISTA, 49

XLT, 52

settings, SmartConnect iPhone, 104

signal strength

VISTA, 51, 62-63

XLT, 55, 62-63

Sleep power state, 74

sleep warning, canceling, 50, 54, 74

slot stickers, 119

Smart Power Switch, 82

upgrading, 115

SmartConnect, 84-85, 90, 94

categorizing events, 29, 99

live streaming, 101

settings, 104

starting and stopping events, 26, 102

snapshots, SmartConnect, 98

- software, Transfer Station, 121
  - special features, 70
    - battery and storage saving, 70
    - Covert Mode, 71
    - recording, 70
  - SSID, SmartConnect, 94
  - staging firmware, 40
  - standard capacity battery, 59
  - start or stop a recorded event, 102
  - starting recorded events, 26
    - automatic, 26, 46, 82, 84
    - manual, 26, 84
    - recording groups, 80
    - SmartConnect, 26, 102
  - static IP, Transfer Station, 121-122
  - status
    - aborting sequence, 50, 54
    - battery
      - VISTA, 51
      - XLT, 54
    - GPS, XLT, 55
    - hotspot, XLT, 55
    - RATF, XLT, 55
    - recording
      - VISTA, 51
      - XLT, 55
    - showing, 50, 54
    - storage
      - VISTA, 51
      - XLT, 55
    - upload
      - VISTA, 51
      - XLT, 55
    - Wi-Fi signal strength
      - VISTA, 51
      - XLT, 55
  - stickers, Transfer Station, 119
  - stopping recorded events
    - 4RE DVR, 82
    - automatic, 26, 46, 76, 84
    - manual, 27
    - SmartConnect, 26, 102
  - storage, 57
    - clearing, 39, 72
    - filled, 72
    - Record After the Fact, 72
    - saving, 70, 76-77
      - VISTA, 51
      - XLT, 55
    - status
      - VISTA, 51
      - XLT, 55
    - storage-full alert, 58
    - Storage Percentage number, VISTA, 58
    - Storage Used icon, XLT, 58
    - Storage Used meter, VISTA, 58
    - Storage Used percentage, XLT, 58
    - subtitles, 47
    - synchronizing playback, 62, 85
- T**
- tagging event, 29
  - text overlay, 47
  - time/date
    - VISTA, 51
    - XLT, 54
  - timestamps, 62
  - tones and vibrations, 57
  - Transfer Station, 65
    - cable connectors, 65
    - configuring, 125
    - docking VISTA, 33
    - LEDs, 65
    - setting up, 66, 118
      - hardware, 119
      - software, 121
    - slot stickers, 119
    - upgrading, 123
    - upgrading camera firmware from, 40
    - uploading from, 37
  - Transfer Station Settings, 121
  - turning on hotspot, 50, 54
- U**
- undocking
    - Transfer Station, 33
    - USB Base, 32
    - WiFi Base, 34
  - upgrading
    - camera, 40
    - Smart Power Switch, 115
    - Transfer Station, 123
    - WiFi Base, 115
  - upload status
    - VISTA, 51
    - XLT, 55
  - uploading recorded events, 37, 47
    - recording group, 85

## Index

- Transfer Station, 37
- USB Base, 37
- WiFi Base, 37
- USB
  - cable connector, 64
  - hub, 31, 42, 59, 61, 64
- USB Base, 64
  - docking VISTA, 31
  - setting up, 64
  - undocking VISTA, 32
  - upgrading camera firmware, 40
  - uploading from, 37
- V**
- vibrations and tones, 57
- video
  - continuous capture, 72
  - pre-event, 71
  - protected, 46
- VISTA Settings, Transfer Station, 122
- W**
- warnings
  - canceling, 50, 54
  - maximum recording time, 76
  - sleep, 74
- wearing
  - VISTA, 15
    - locking chest mount, 16
    - MOLLE vest mount, 17
    - other mounts, 18
  - XLT, 19
    - belt clip, 20
    - body-mounted camera, 22
    - DVR, 20
    - head-mounted camera, 21
    - holster, 20
- Wi-Fi
  - access point, 50, 54, 84-85, 90
  - antenna connector, 68
  - feature, 61
  - signal strength
    - VISTA, 51, 62
    - XLT, 55, 62
- WiFi Base, 66
  - charging from, 66
  - docking VISTA, 34
  - LEDs, 67
  - pairing, 44, 83
  - recording group member, 83
  - setting up, 68
  - upgrading, 115
  - upgrading camera firmware, 40
  - uploading, 37
- wireless
  - access point, 84-85, 90
  - radio, 85
- workflow, 14