

FCC and Industry Canada Compliance Information

This equipment has been tested and found to comply with the limits for a Class A digital device, pursuant to part 15 of the FCC Rules. These limits are designed to provide reasonable protection against harmful interference when the equipment is operated in a commercial environment. This equipment generates, uses, and can radiate radio frequency energy and, if not installed and used in accordance with the instruction manual, may cause harmful interference to radio communications. Operation of this equipment in a residential area is likely to cause harmful interference in which case the user will be required to correct the interference at his own expense.

This device complies with Part 15 of the FCC Rules and Industry Canada license-exempt RSS standard(s). Operation is subject to the following two conditions:

- this device may not cause harmful interference, AND
- this device must accept any interference received, including interference that may cause undesired operation.

Changes or modifications not expressly approved by Enlighted Inc. could void the user's authority to operate the equipment.

Le présent appareil est conforme aux CNR d'Industrie Canada applicables aux appareils radio exempts de licence. L'exploitation est autorisée aux deux conditions suivantes:

- l'appareil ne doit pas produire de brouillage, ET
- l'utilisateur de l'appareil doit accepter tout brouillage radioélectrique subi, même si le brouillage est susceptible d'en compromettre le fonctionnement.

CE

This device complies with the essential requirements and other relevant requirements of the R&TTE Directive (1999/5/EC). The equipment is Class 1 radio equipment which can be placed on the market and be put into service without restrictions in accordance with article 1(3) of Commission Decision 2000/299/EC (Version July 2014).

Model: SU-4S

FCC ID: AQQ-SU4S

IC: 10138A-SU4S



Copyright © 2016 Enlighted Inc. All rights reserved.
All other brand or product names are trademarks of their respective companies or organizations.

Technical Support

For questions regarding the installation or operation of this product, contact Enlighted

Technical Support: support@enlightedinc.com

Company Contact Information

Location: 930 Benecia Ave, Sunnyvale, CA 94085

Phone: +1.650.964.1094

Web: enlightedinc.com



Ruggedized Sensor (SU-4S) Installation Instructions

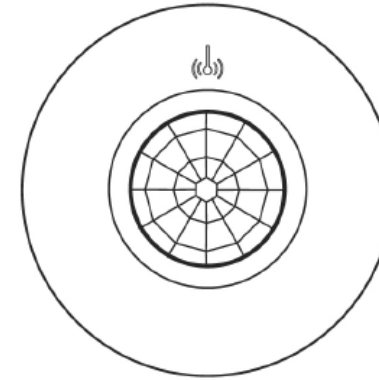

FRONT SIDE OF SENSOR UNIT

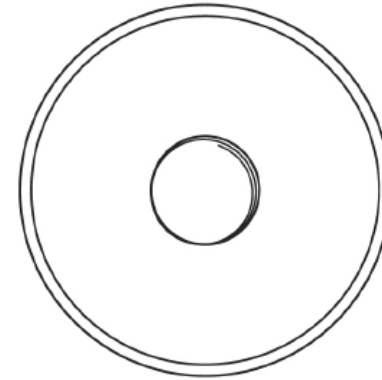

BACK SIDE OF SENSOR UNIT

Ruggedized Sensor (front and back)

Applicable For:

SU-4S-LRW; SU-4S-LRB

SU-4S-HRW; SU-4S-HRB

Shipped Components

Enlighted Ruggedized Sensor Unit

½ inch Lock Nut

Tools you may Need

½ inch Knock out tool

Items you will Need

½ inch LB Conduit Body

½ inch Chase Nipple

Caution

Installation and maintenance must be performed by a qualified electrician in accordance with local, state, and national electrical codes (NEC) and requirements.

Installation

The Ruggedized sensor is shipped with the cable attached to the sensor. Figure 1.

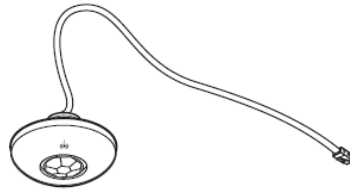

Figure 1

Step 1: Turn off all power to the light fixture by switching off the circuit breaker.

Step 2: Mount the Control Unit (CU) in a UL approved enclosure. Refer to the *Control Unit Installation Guide*. See Figure 7 for detailed wiring connections from the CU.

Step 3: Remove the cover plate of the ½ inch LB conduit body by removing the two screws. Figure 2.

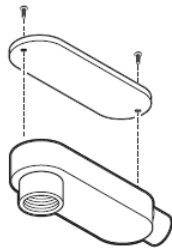

Figure 2



Figure 3

Step 4: Thread the Ruggedized sensor onto LB conduit body. Figure 3.

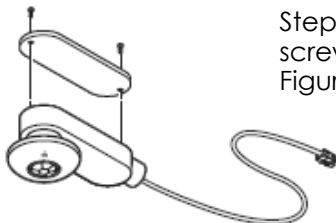

Figure 4

Step 5: Replace the cover and two screws on the LB conduit body. Figure 4.

Step 6: Knock out a ½ inch hole on the end of the light fixture. Using the ½ inch chase nipple, connect the LB conduit to the fixture. See Figure 5.

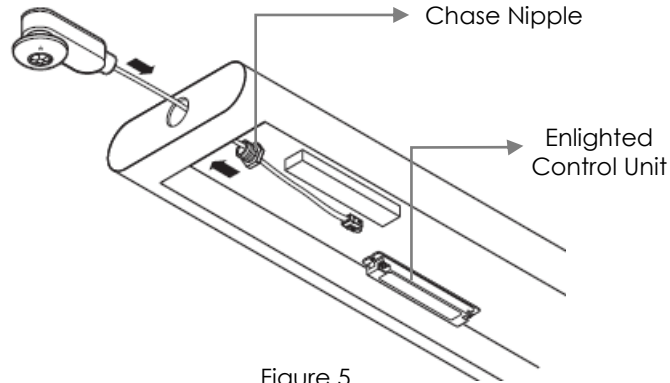

Figure 5

Step 7: Pull the Ruggedized sensor cable through the chase nipple into the fixture and connect it to the Control Unit. See Figure 6. For wiring connections to the CU, see Figure 7.

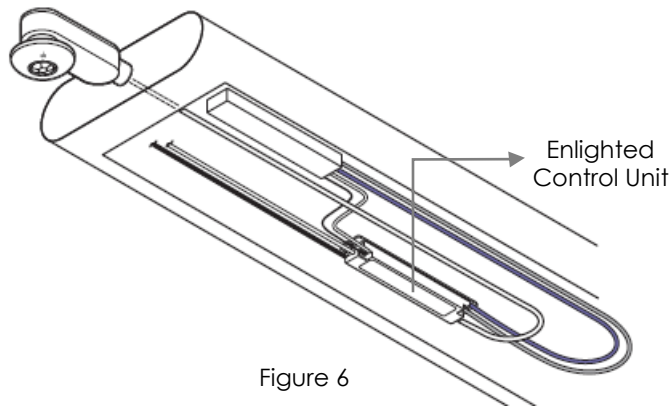

Figure 6

Step 8: If the ruggedized sensor cable is not long enough to reach the Control Unit, use an RJ12 coupling to connect the rugged sensor cable to an Enlighted 7ft Sensor cable. (CBL-2-7F)

Step 9: Switch on the circuit breaker to turn the power on.

LED Description

LED Status	Description/Solution
LED not on	Check power and wiring
Purple solid	All LEDs are on during boot time for 5-6 seconds
Green blinking	Sensor commissioned and working
Red blinking	Incompatibility between LED driver and sensor – Replace LED driver and if not resolved, replace sensor.
Red solid	Faulty sensor – replace sensor
Green solid	Sensor installed, initialized, and uncommissioned – waiting for discovery.
Blue solid	Image being upgraded.

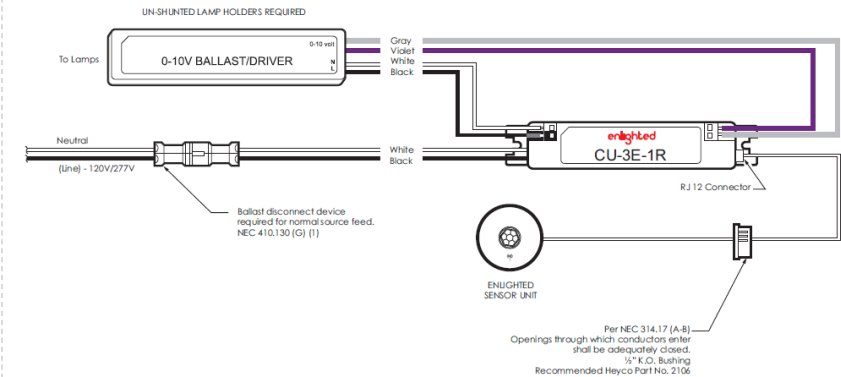

Figure 7