

FCC and Industry Canada Compliance Information

This equipment has been tested and found to comply with the limits for a Class A digital device, pursuant to part 15 of the FCC Rules. These limits are designed to provide reasonable protection against harmful interference when the equipment is operated in a commercial environment. This equipment generates, uses, and can radiate radio frequency energy and, if not installed and used in accordance with the instruction manual, may cause harmful interference to radio communications. Operation of this equipment in a residential area is likely to cause harmful interference in which case the user will be required to correct the interference at his own expense.

USA

This device complies with Part 15 of the FCC Rules. Operation is subject to the following two conditions:

- this device may not cause harmful interference, AND
- this device must accept any interference received, including interference that may cause undesired operation.

Changes or modifications not expressly approved by Enlighted Inc. could void the user's authority to operate the equipment.

Canada

This device complies with Industry Canada license-exempt RSS standard(s). Operation is subject to the following two conditions:

- this device may not cause harmful interference, AND
- this device must accept any interference received, including interference that may cause undesired operation.

Changes or modifications not expressly approved by Enlighted Inc. could void the user's authority to operate the equipment.

Le présent appareil est conforme aux CNR d'Industrie Canada applicables aux appareils radio exempts de licence. L'exploitation est autorisée aux deux conditions suivantes:

- l'appareil ne doit pas produire de brouillage, ET
- l'utilisateur de l'appareil doit accepter tout brouillage radioélectrique subi, même si le brouillage est susceptible d'en compromettre le fonctionnement.

CE

This device complies with the essential requirements and other relevant requirements of the R&TTE Directive (1999/5/EC). The product is compliant with the following standards and/or other normative documents. EN 62479, ETSI EN 301, EN 300

- The equipment is Class 1 radio equipment which can be placed on the market and be put into service without restrictions in accordance with article 1(3) of Commission Decision 2000/299/EC (Version July 2014).

Model: WS-2-00

FCC ID: AQQ-WS-2-00

Industry Canada: 10138A-WS200



Copyright © 2014 Enlighted Inc. All rights reserved.
All other brand or product names are trademarks of their respective companies or organizations.

Technical Support

For questions regarding the installation or operation of this product, contact Enlighted

Technical Support: support@enlightedinc.com

Company Contact Information

Location: 930 Benecia Ave, Sunnyvale, CA 94085

Phone: +1.650.964.1094

Web: enlightedinc.com

CA Contractor's License: CCL# 980903



Wireless Switch 2 (WS2) Model WS-2-00 Installation Instructions

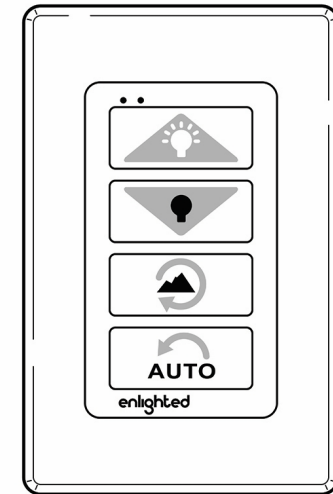

Figure 1: Enlighted Wireless Switch 2 (WS2)

Shipped Components

- Wireless switch version 2 (WS2)
- Usage card
- Back plate (with captive screws in place)
- Cover plate
- 2 tapping screws
- 2 6-32 machine screws

Tools You May Need

- Phillips screw driver
- Flat head screw driver

Cautionary Suggestions

- Installation and maintenance must be performed by a qualified electrician.
- Installations and maintenance must be performed in accordance with state, local, and national electrical codes and requirements.

Installation Steps

Both Wall and Junction Box Mounting

Step	Description
1	Separate, if needed, the cover and back plates.
2	Remove the plastic pull tab from the WS2 to allow the battery to come in contact with the terminals. (See figure 2)
3	Press each button and verify that both the green and red LEDs flash and that the button moves smoothly. (See figure 3)
4	If the LEDs do not flash when a button is pressed, then check, and if needed, replace the battery. The battery is accessed after opening the case as shown in figure 4.
5	Position the WS2 on either the wall or on a junction box with the LEDs on the top and the Enlighted logo on the bottom. (See Figure 5)
6	Use the provided tapping screws (or machine screws for a junction box) to attach the WS2 to the wall.
7	Align the back plate (with the arrow pointing up) to the WS2. Affix the back plate to the WS2 by firmly tightening both captive screws.
8	Snap on the cover plate with the arrow (on its back side) pointing up.
9	Save usage card for room occupants.

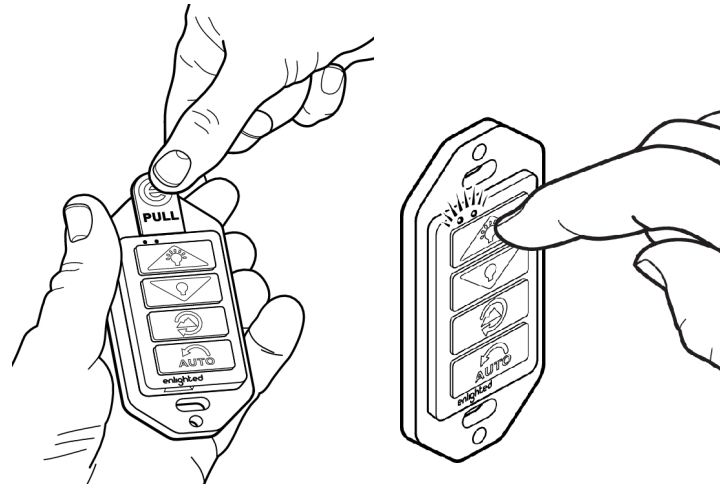

Figure 2: Remove plastic pull tab to allow battery to power unit

Figure 3: Press each button to verify operation and that LEDs flash

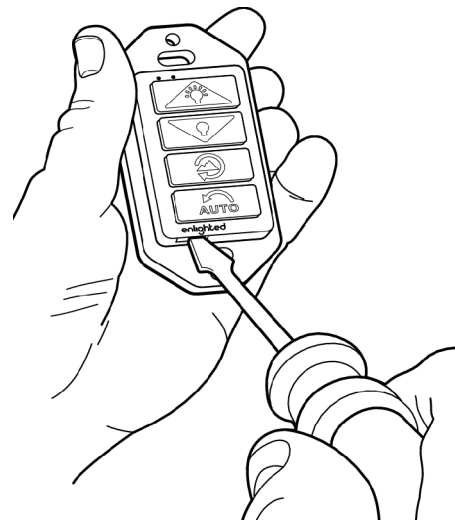

Figure 4: Opening the WS2's case to access the battery

Troubleshooting

Problem	Solution
LEDs do not flash when a button is pressed	The energy in the battery may have drained. Check, and if needed, replace the battery (see Figure 4)
Buttons do not easily move when pressed	Return unit for replacement

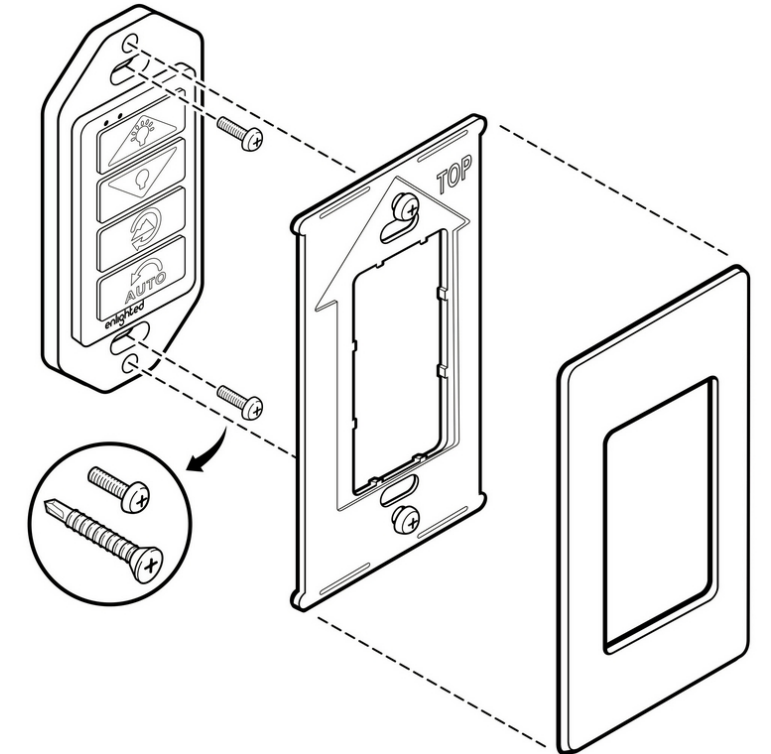

Figure 5: Mounting Sequence