

HT840

V/01

VHF submersible marine handheld transceiver

OWNERS MANUAL

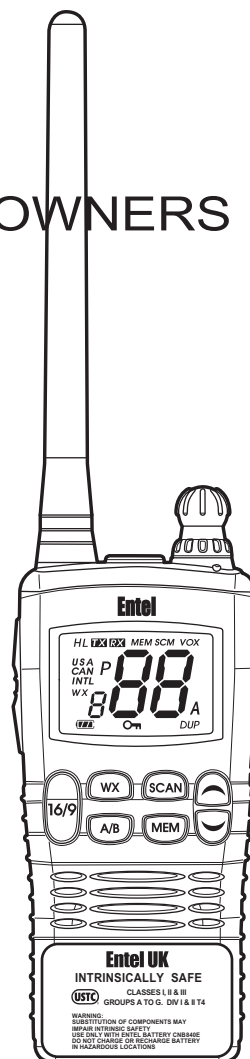

Class I, II & III
Groups A TO G.
DIV I & II T4

Submersible
Dependable
Tough

Entel UK

USA Versions:-

This device complies with part 15 of the FCC rules. Operation is subject to the following two conditions: (1) This device does not cause harmful interference, and (2) this device must accept any interference received, including interference that may undersired operation..

European Versions:-

CE COMPLIANCE STATEMENT

The HT840 transceiver displays "CE" on the serial number label, indicating its compliance with the essential requirements of the EEC directive for Electromagnetic Compatibility.

DECLARATION OF CONFORMITY

We, Entel UK Limited.

Of:-
4 Elstree Gate, Elstree Way,
Borehamwood, Herts.
WD6 1JD
United Kingdom.

Declare under our sole responsibility that the product:-
HT840 VHF Marine Submersible Transceiver

Serial Number.....
to which this declaration relates is in accordance with directive 95/5/EC and conforms to the following standards or other nominative documents :-
EN 301 178-2 V 1.1.1 (2000-08), EN60950 August 1992, A11 1997
EN 60945 1997 & ETS 300 698 Annex B December 1996(Version D only)
following the provisions of the R&TTE directive.



M. Austin
Quality Manager
5th March 2004



TABLE OF CONTENTS

1.1 INTRODUCTION	04
1.2 PACKING LIST	04
1.3 OPTIONAL ACCESSORIES	05
1.3.1 ATTACHING AUDIO ACCESSORIES	06
1.4 CONTROLS AND INDICATORS	06
1.5 INDICATORS	09
1.6 RECEPTION	10
1.7 TRANSMITTING	11
1.8 INT, USA, & CANADIAN MODES	11
1.9 NOAA WEATHER CHANNELS	12
2.0 SCAN	12
2.1 EMERGENCY CHANNELS	13
2.2 CHANNEL 9	13
2.3 CHANNEL A/B INSTANT ACCESS	13
2.3.1 PROGRAMMING A/B INSTANT ACCESS BUTTONS	14
2.4 OPERATION OF A/B INSTANT ACCESS BUTTONS	14
2.5 VOICE SCRAMBLER	15
2.6 VOX (voice operated transmit)	15
2.7 SIMPLEX/DUPEX CHANNEL USE	16
2.8 BATTERY CHARGING	16
2.8.1 OPTIONAL RAPID CHARGER	17
2.9 BATTERY REMOVAL/INSTALLATION	17
3.0 BATTERY INDICATOR	18
3.1 BATTERY SAFETY	18
3.2 TROUBLE SHOOTING	20
3.3 GLOSSARY OF TERMS	21
3.4 CHANNEL CHART	22
(INT, USA, CANADIAN AND private)	
3.5 SPECIFICATION	25
(General, receive and transmit)	
3.5.1 PRIVATE CHANNELS	26

1.1 INTRODUCTION

The **Entel HT840** is a professional marine handheld transceiver that operates on the VHF marine band. The **HT840** has 58 marine international channels, 10 weather, and 36 dealer programmable private channels. The 58 marine channels are switchable to comply with USA, International or Canadian regulations, this is done via the keypad. It has an emergency channel 16 button, which can be immediately selected from any channel by pressing the red **16/9** key. Weather channels can also be accessed immediately by pressing **WX** key.

The **HT840** includes the following features: Scan, A/B quick access channels, voice scrambler, battery life indicator, vox (voice operated transmit), low battery indicator, large LCD with back light,

1.2 PACKING LIST

The supplied package: (U.S.T.C Certified, intrinsically safe)

- ▶ **HT840** Marine transceiver
- ▶ **CNB840E** 1800mAh rechargeable lithium-Ion battery pack
- ▶ **CAT40IS** Flexible antenna
- ▶ **CBH940** Spring loaded belt clip
- ▶ **Owners manual**

1.3 OPTIONAL ACCESSORIES (U.S.T.C Certified)

The **HT840** is supported by a wide range of essential accessories.
For an up to date list visit our web site at www.entel.co.uk

CSA640E	Single pod intelligent rapid charger, 110/230v operation
CSB640E	Six pod intelligent rapid charger, 110/230v operation
CST640E	3 or 6 pod battery conditioner/analyser
CCA230	230v drop in trickle charger. (Also available as 110v -CCA110)
CCA12	12v drop in trickle charger
CNB840E	7.4V 1800mAh rechargeable lithium-Ion battery pack, with rear clip

NOTE: DO NOT CHARGE OR REMOVE THE BATTERY PACK IN THE HAZARDOUS AREA LOCATION.

CMP840	Submersible, noise cancelling speaker microphone (heavy duty)
EA19/840	Earpiece microphone with PTT button
EA15/840	Covert style ear/microphone with transparent acoustic tube
EA12/840	D Shape earpiece microphone with in-line PTT
CHP1/840	Single earpiece headset with in-line PTT(vox)
EPT40/840	Bone conductive earpiece microphone
CHP800/HD	Heavy duty double ear defender for hardhat with PTT (vox)
CHP800/HS	Heavy duty single ear defender for hardhat and PTT (vox)
CHP800D	Heavy duty double ear defender with headband and PTT (vox)
CXR5/840	Skull microphone (vox)
CXR16/840	Throat microphone (vox)
EHP840	Covert style earpiece
CLC940	Heavy duty leather case with belt loop & carry strap
CAT40IS	Flexible antenna
CBH940	Spring loaded rear clip

NOTE: THE USE OF NON ENTEL APPROVED ACCESSORIES WILL INVALIDATE YOUR U.S.T.C INTRINSICALLY SAFE APPROVAL

Accessories suitable for vox operation have been marked (vox)

1.3.1 ATTACHING AUDIO ACCESSORIES

Locate accessory connector cover marked "ACC" Lift cover and rotate (screw) the connector as shown in the diagram below.

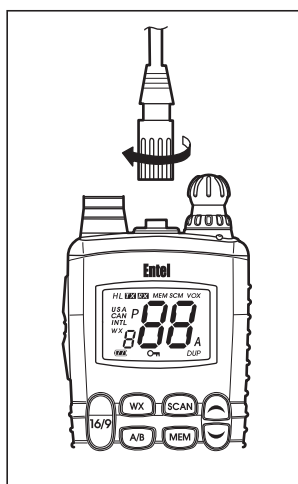

Note: The accessory socket is waterproof without the ACC cover in place. However, when not using an audio accessory we strongly advise keeping the ACC cover firmly pressed in its recess to prevent foreign objects from getting into the socket.

Figure 1. Attaching the accessory connector

1.4 CONTROLS AND INDICATORS

① **POWER SWITCH/VOLUME CONTROL**

Powers the transceiver on and off, and adjusts volume level.

② **SQUELCH CONTROL**

To set the squelch, rotate the control fully anti-clock wise, then rotate the control clockwise until the white noise stops. If you occasionally get breakthrough of unwanted noise, rotate the control a little further clockwise.

③ **PUSH TO TALK SWITCH**

Hold down to transmit, release to receive.

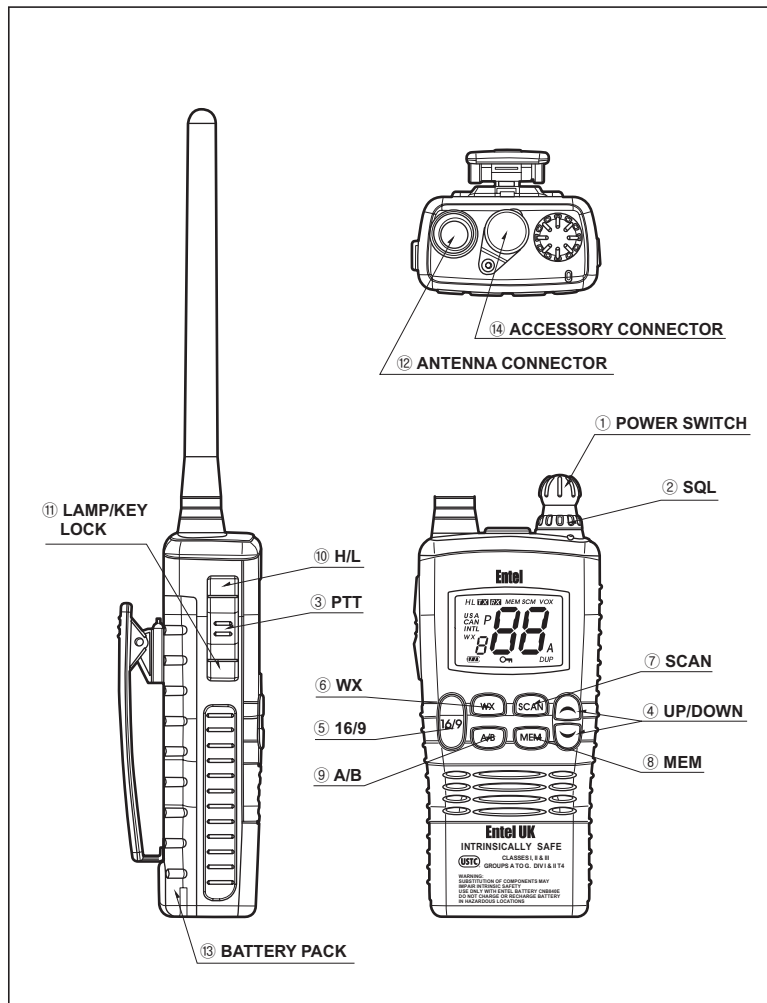

Figure 2. Controls and Connectors

- ④ **UP/DOWN buttons**
Select the desired channel by pressing the UP/DOWN buttons.
For fast channel selection hold down for more than 1 second.
- ⑤ **16/9 button**
A momentary press of this button recalls channel 16 from any location. Holding this button for 1 second recalls channel 9.
- ⑥ **WX button**
Immediately recalls the weather channels.
- ⑦ **SCAN button**
Starts scanning programmed channels.
- ⑧ **MEM button**
Memorises a desired channel for scanning.
- ⑨ **A/B button**
Immediately recalls up to 2 user-defined channels.
- ⑩ **H/L button**
Press this button for one second to toggle between high and low power. (1 & 5 watts)
- ⑪ **LAMP/KEY LOCK**
Momentarily pressing this button illuminates the LCD display.
Holding this button for over 1 second activates the key lock.
To deactivate press button again.
- ⑫ **ANTENNA CONNECTOR**
Connects the supplied flexible antenna or an optional external aerial adaptor.
- ⑬ **BATTERY PACK**
Rechargeable lithium-Ion battery pack provides DC power source to the transceiver.
- ⑭ **ACCESSORY CONNECTOR**
To connect any HT840 approved audio accessory.

1.5 INDICATORS

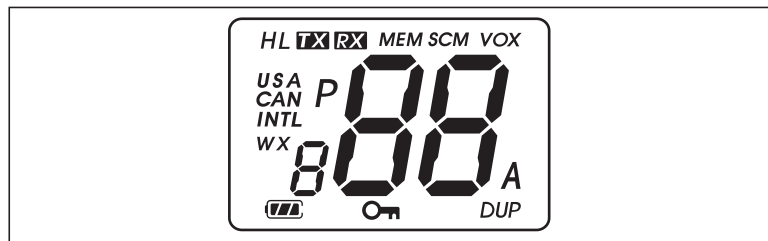

Figure 3. LCD indications

CHANNEL DISPLAY

The operating channel.

H/L

H indicates high power (5 watts) L indicates low power (1 watt)

USA/CAN/INTL

Indicates the channel set for; USA, Canadian, and International waters.

A Indicator

A ship-to-ship channel in U.S.A or Canadian mode whose counterpart in the International mode is a public correspondence (marine operator) channel.

WX

NOAA weather channel (U.S.A & Canadian waters only)

TX Indicator

Indicates transmission in progress

VOX

Voice operated mode enabled

SCAN

SCAN mode in progress

MEM

Indicated channel is memorised for scanning

SCM

Scrambler mode enabled (versions A & B only)

LAMP /

The keypad is locked, with the exception of the [PTT], [H/L] and [LAMP] buttons.

BATTERY LIFE INDICATOR

The lithium-Ion battery of your transceiver is continually monitored for your convenience and safety.

1.6 RECEPTION

1. Turn the transceiver on by rotating the volume control in a clockwise direction. A power on tone is generated after 1 second to indicate the transceiver has passed its self-diagnostic test. During standby the LED indicator will pulse amber every 3 seconds, to further verify its circuitry is functioning correctly. Select the desired audio level by further rotating the control clockwise. After power on, the transceiver will always default to the last channel selected.
2. Turn the squelch control fully counter clockwise, then rotate clockwise until the white noise stops. This condition is known as the "squelch threshold" If the control is turned clockwise past this point, weak signals may not be received.
No noise or signal is heard until a signal is received that exceeds the squelch threshold.
3. Select the desired channel using the [UP/DOWN] buttons.
A full listing of channels can be found on page 22.
Sometimes, a slight adjustment of the squelch threshold is needed as some channels have a higher noise level than others.
4. When receiving a signal the LED indicator illuminates green.
A "RX" indication is also displayed on the LCD.

1.7 TRANSMITTING

1. Perform steps 1 through 3 of RECEPTION.
2. Before transmitting, monitor the channel and make sure it is clear.
3. For communications over short distances, press the [H/L] key and select low power (1 watt) Transmitting on 1 watt prolongs battery life, and should be selected whenever possible.
4. When receiving a signal, wait until the signal stops before transmitting. The transceiver cannot transmit and receive simultaneously.
5. Press the [PTT] (push-to-talk) switch to begin your transmission. To confirm transmission in progress the LCD indicator illuminates TX and the LED illuminates RED.
6. Holding the transceiver 1 inch from your mouth speak slowly and clearly into the microphone.
7. When the transmission is finished, release the [PTT] switch.

1.8 INT, USA, & CANADIAN MODES

**In compliance with worldwide license regulations
the following version of HT840 are available:**

Version A : INT, USA, & Canadian modes

Version B, C and D : INT mode only

1. In the case of version A only ; to change the channel set of the transceiver, hold down the [WX] key, The mode changes from U.S.A to Canadian to International.
2. Refer to the marine channel charts in this booklet for allocated channels in each mode.

1.9 NOAA WEATHER CHANNELS

(Applicable to version A model only)

1. To receive a weather channel, press the [WX] key.
The transceiver enters into weather channel mode.
2. There are 10 weather channels. Use the UP or DOWN buttons to select the desired weather channel.
3. To exit from the weather channels, press the [WX] key.
The transceiver recalls the previous working channel.

2.0 SCAN

1. Select the desired channel to be scanned using the \wedge & \smile buttons.
2. Press the [MEM] button to store the channel into the transceivers memory. [MEM] is displayed on the LCD.
This channel is now memorised to be scanned.
3. To scan further channels, repeat steps 1 & 2.
4. To delete a channel from the transceivers scan memory, simply press [MEM] button again whilst the memorised channel is displayed. [MEM] disappears.
5. All channels programmed remain in the transceivers scan memory, even if the power is switched off.
6. Adjust the squelch control until the white noise is eliminated.
7. To start scanning, press the [SCAN] key. The scan proceeds from the lowest to the highest programmed channel number and stops on channels when a transmission is received.
8. To stop the scan at any time, press the [SCAN] key.

2.1 EMERGENCY CHANNELS

To select the emergency channel, press the [16/9] button from any channel. Channel 16 appears on the display. To recall the previous channel used, press the [16/9] button once again.

2.2 CHANNEL 9

Channel 9 is used as a hailing channel for initial, non-emergency contact with other vessels. Hold down the [16/9] key for 1 second to select channel 9.

2.3 CHANNEL A/B INSTANT ACCESS

For your convenience, two user assigned channels can be programmed for instant access. If the [A/B] key is pressed and no channel A or B has been assigned, a short beep will be heard.

2.3.1 PROGRAMMING A/B INSTANT ACCESS BUTTONS

1. Hold down the [A/B] key and turn on the transceiver.
2. The letter A will appear on the display, and dashes "_ _" indicate that no channel has been designated channel A.
3. Press the [UP/DOWN] key until the desired channel number is displayed.
4. With the desired channel number displayed, press the [MEM] key once. The "A" will stop flashing, indicating that the displayed channel is now designated channel A.
5. Press the A/B button again. The letter "b" will appear on the display. Repeat steps 2 through to 4.
6. Switch transceiver off and on to exit this mode and save changes.

NOTE: Should you later wish to delete any stored channels simply press "MEM" key whilst in A/B programming mode.

2.4 OPERATION OF A/B INSTANT ACCESS BUTTONS

Pressing the [A/B] button will toggle between A, B and the previous selected working channel. Channel A is represented by the "A" to the left of the channel number on the LCD, and channel B is represented by "b". NOTE: Do not confuse this "A" with the one that is sometimes displayed to the right hand side of the channel number (in U.S.A and Canadian modes)

2.5 VOICE SCRAMBLER (HT840 versions A & B only)

Press the [SCAN] key and switch the transceiver on simultaneously. "SCM" will be displayed on the LCD **confirming that the voice scrambler of your HT840 is now activated.**

NOTE: The scrambler cannot be enabled on channel 16 & 9.

To exit scramble mode simply switch the radio off and on.

**Legislation for the use of a scrambler (encryption) varies from country to country. We recommend that you check with your dealer prior to using this feature.

2.6 VOX(voice operated transmit)

Press the [MEM] button and switch the transceiver on. VOX will be displayed on the LCD, along with "oFF" which indicates VOX is switched off, 1 is for low sensitivity, 5 is for normal sensitivity, and 9 is for high sensitivity. Use the [UP/DOWN] button to select the desired level,press MEM to confirm, the transceiver is now set to VOX. To switch VOX off, go back into VOX programming mode by holding the "MEM" button whilst switching on. Press the UP/DOWN button until the vox level is "OFF".

In VOX mode the transceiver will react to your voice, and transmit automatically without you having to press the PTT button. There is always a slight delay for the electronic switching, and consideration will need to be given. To get optimum performance from the VOX feature you should use a noise cancelling headset or earpiece microphone (see accessory options)

2.7 SIMPLEX/DUPLEX CHANNEL USE

Your transceiver has been factory programmed in accordance with FCC (USA), industry Canada and International regulations. The mode of operation cannot be altered from simplex to duplex or vice versa. Simplex or duplex mode is automatically activated, depending on the channel and the channel set and whether USA, Canadian, or International mode is selected. Refer to the channel charts listed later in this user manual.

If you have a license to use a specific simplex or semi-duplex channel, contact your dealer who may be able to program your channel using the transceivers private channel memory.

2.8 OPTIONAL TRICKLE CHARGER -model CCA230

1. Connect the CWC640 AC adaptor to the charger pod.
The LED status light will illuminate green indicating ready for charge.
2. Turn the transceiver off.
3. Insert the battery pack into the pod, either with or without the transceiver attached. The LED status light changes from green to RED and trickle charge begins.
4. A fully discharged battery pack will take approximately 6 hours to charge, depending on the remaining power condition. When charge is complete, the LED status light turns green.

NOTE: The CWC640 AC adaptor can be replaced by the CMC640 12v charger cable. Charge time remains at 6 hours.

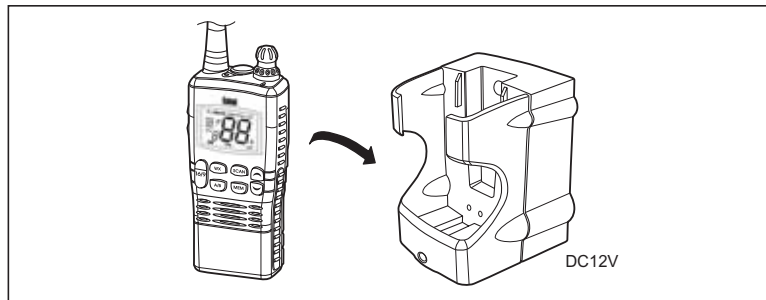

Figure 4. OPTIONAL CCA230 trickle charger

2.8.1 OPTIONAL RAPID CHARGER-model CSA640E

1. Connect the CSA640E to a mains supply(110 to 230V). When switching on the LED flashes orange briefly to confirm self-diagnostic test complete.

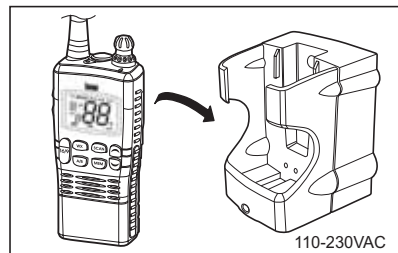

Figure 4-1. OPTIONAL CSA640E rapid charger

2. Turn the transceiver off.
3. Insert the battery pack into the CSA640E charger, either with or without the transceiver attached. The LED will illuminate red to indicate rapid charge in progress.
4. Charge time for a fully discharged battery pack will take up to 120 minutes. On completion the LED turns green.

2.9 BATTERY REMOVAL/INSTALLATION

1. Turn the transceiver off.
2. Using a coin, rotate the battery screw anti-clockwise 2 or 3 turns.
**Ensure that you do not hold the battery pack when unscrewing the release screw!

3. To attach battery, locate the bottom section of the battery and press the battery against the transceiver, and rotate the battery screw clockwise.

NOTE: The HT840 must only be used with the CNB840E battery pack manufactured by Entel UK. Failure to comply will invalidate your USTC Certification.

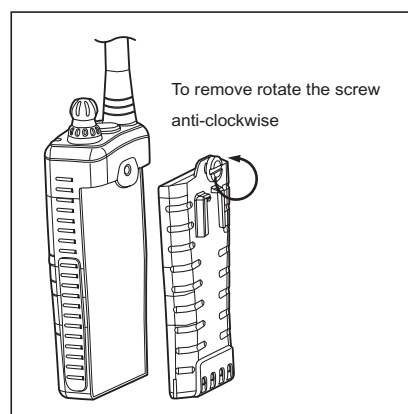

Figure 5. Battery removal / attachment

3.0 BATTERY INDICATOR

For your safety and convenience your transceiver continually monitors the battery pack and gives an indication on the LCD:

- 3 Segments : 12hours
- 2 Segments : 1hour
- 1 Segment : 20mins



Figure 6. Battery Indicator

3.1 BATTERY SAFETY

The battery pack of your transceiver contains lithium-Ion cells. This type of battery stores a charge powerful enough to be dangerous if misused or abused, especially when removed from the transceiver. Please observe the following precautions detailed on page 19.

DO NOT SHORT BATTERY PACK TERMINALS

Shorting the terminals that power the transceiver can cause sparks, severe over heating, burns, and battery cell damage.

If the short is of sufficient duration, it is possible to melt the battery components. Do not place a loose battery pack on or near a metal surface or objects such as paper clips, keys, tools etc.

When the battery pack is installed on the transceiver, the terminals that transfer current to the transceiver are not exposed.

The terminals that are exposed on the battery pack when it is mounted on the transceiver are charging terminals only and do not constitute a hazard.

DO NOT OVERCHARGE

When using the CWC640 do not charge the transceiver for more than 8 hours. Heat generated by overcharging can shorten battery life and cause other battery pack component failures

DO NOT INCINERATE

Do not dispose of your CNB840E battery in a fire or incinerator. The heat of fire may cause battery cells to explode and/or release dangerous gases.

DISPOSE OF BATTERY PACKS PROPERLY

Lithium-Ion battery packs must be recycled or disposed of properly. For requirements in your area, check with the dealer from whom you purchased your transceiver.

3.2 TROUBLE SHOOTING

TROUBLESHOOTING CHART		
SYMPTOM	PROBABLE CAUSE	REMEDY
Transceiver not switching on	Battery needs charging Battery is exhausted	Charge the battery pack Replace the battery pack
The scan key does not start the scan	No channels memorised (MEM) Squelch is not adjusted	Use the MEM key to enter desired channels into scan memory Adjust the squelch to threshold or to the point where the white noise just disappears.
Cannot change any function	Key lock is switched on	Turn key lock off
LED on CCA230 & CWC640 does not illuminate when charging	Defective battery, CCA230, or CWC640 Dirty terminal contact on CCA230	Contact your dealer Clean contacts with dry clean cloth
No transmit or Hi power can be selected	Some channels are low power only Battery pack exhausted	Change to high power channel Recharge the battery pack
Transceiver transmits without pressing PTT button Buttons seem to work intermittently	VOX has been enabled	Hold MEM button for 2 secs, use UP or DOWN button and select 0 to turn VOX off.

3.3 GLOSSARY OF TERMS

Canadian Channels Channels designated as defined and regulated by Industry Canada, (RIC), Marine Communications & Traffic Services.

Duplex Transmit and receive on different frequencies

Encryption scrambled audio, for extra privacy

FM Frequency modulation

International channels Channel designations as defined for use in International waters by the International Telecommunications Union (ITU)

Marina channels Special channels reserved for marinas located in selected European countries. These channels are pre-programmed in the transceiver as P1 & P2.

Private channels Channels, which are assigned by regulatory agencies governing VHF radio use for a specific region or country. These channels are prefixed with a "P" and can only be programmed into the transceiver by authorised dealers.

PTT Press to talk (transmit)

RX Receive

Simplex Transmit and receive on the same frequency

Squelch To suppress background noise

TX Transmit

Transceiver A device that can transmit and receive

U.S.A channels Channel designations as defined by the Federal Communications Commission, (FCC)

VOX Voice Operated Transmit

VHF Very High Frequency (30MHz to 300 MHz)

**Based on duty cycle of 5%TX, 5%RX, 90%STANDBY

3.4 CHANNEL CHART(INT, USA, CANADIAN AND PRIVATE)

VHF MARINE CHANNEL CHART							
CH	U	C	I	S/D	TX	RX	CHANNEL USE
01A	X			S	156.050		Port Operation and Commercial. VTS in selected areas
01		X	X	D	156.050	160.650	Public Correspondence (Marine Operator)
02		X	X	D	156.100	160.700	Public Correspondence (Marine Operator)
03A	X			S	156.150		US Government only, Coast Guard
03		X	X	D	156.150	160.750	Public Correspondence (Marine Operator)
04A	X			S	156.200		Pacific coast: Coast Guard, East Coast: Commercial fishing
04			X	D	156.200	160.800	Public Correspondence (Marine Operator), Port operation, ship movement
05A	X	X		S	156.250		Port operation. VTS in Seattle
05			X	D	156.250	160.850	Public Correspondence (Marine Operator), Port operation, ship movement
06	X	X	X	S	156.300		Inter-ship Safety
07A	X	X		S	156.350		Commercial
07			X	D	156.350	160.950	Public Correspondence (Marine Operator), Port operation, ship movement
08	X	X	X	S	156.400		Commercial (Inter-ship only)
09	X	X	X	S	156.450		Boater Calling channel, Commercial & Non-commercial (Recreational)
10	X	X	X	S	156.500		Commercial
11	X	X	X	S	156.550		Commercial. VTS in selected areas.
12	X	X	X	S	156.600		Port operation. VTS in selected areas.
13	X	X	X	S	156.650		Inter-ship Navigation Safety (Bridge-to-bridge)
14	X	X	X	S	156.700		Port operation. VTS in selected areas.
15		X	X	S	156.750		Commercial, non-commercial, ship movement (1W)
16	X	X	X	S	156.800		International Distress, Safety and Calling
17	X	X	X	S	156.850		State Controlled (1W)
18A	X	X		S	156.900		Commercial
18			X	D	156.900	161.500	Port operation, ship movement
19A	X			S	156.950		US: Commercial
19A		X		S	156.950		Coast Guard
19			X	D	156.950	161.550	Port operation, ship movement
20A	X			S	157.000		Port Operation
20		X	X	D	157.000	161.600	Canadian Coast Guard Only, International: Port operation and shipment
21A	X	X		S	157.050		U.S. Government only, Canadian Coast Guard
21			X	D	157.050	161.650	Port operation, ship movement
22A	X	X		S	157.100		US and Canadian Coast Guard Liaison and Maritime Safety Information Broadcasts announced on channel 16
22			X	D	157.100	161.700	Port operation, ship movement
23A	X			S	157.150		U.S. Government only
23		X	X	D	157.150	161.750	Public Correspondence (Marine Operator)
24	X	X	X	D	157.200	161.800	Public Correspondence (Marine Operator)
25	X	X	X	D	157.250	161.850	Public Correspondence (Marine Operator)
26	X	X	X	D	157.300	161.900	Public Correspondence (Marine Operator)
27	X	X	X	D	157.350	161.950	Public Correspondence (Marine Operator)
28	X	X	X	D	157.400	162.000	Public Correspondence (Marine Operator)

VHF MARINE CHANNEL CHART							
CH	U	C	I	S/D	TX	RX	CHANNEL USE
60		X	X	D	156.025	160.625	Public Correspondence (Marine Operator)
60A	X	X		S	160.075		U.S. Government only, Canadian Coast Guard-Pacific Coast, Commercial Fishing-East Coast
61			X	D	156.075	160.675	Public Correspondence (Marine Operator), Port operation, ship movement
62A		X		S	156.125		Pacific coast: Coast Guard; East Coast: Commercial fishing only
62			X	D	156.125	160.725	Public Correspondence (Marine Operator), Port operation, ship movement
63A	X			S	156.175		Port Operation and Commercial. VTS in selected areas.
63			X	D	156.175	160.775	Public Correspondence (Marine Operator), Port operation, ship movement
64A	X	X		S	156.225		U.S. Government only, Canadian Commercial Fishing
64			X	D	156.225	160.825	Public Correspondence (Marine Operator), Port operation, ship movement
65A	X	X		S	156.275		Port Operations
65			X	D	156.275	160.875	Public Correspondence (Marine Operator), Port operation, ship movement
66A	X	X		S	156.325		Port Operations
66			X	D	156.325	160.925	Public Correspondence (Marine Operator), Port operation, ship movement
67	X	X	X	S	156.375		US: Commercial. Used for Bridge-to-bridge communications in lower Mississippi River. Inter-ship only, Canada: Commercial fishing, S&R
68	X	X	X	S	156.425		Non-commercial (Recreational)
69	X	X	X	S	156.475		US: Non-commercial (Recreational), Canada: Commercial fishing only, International: Port operations and Ship movement
70	X	X	X	S	156.525		Digital selective calling (voice communications not allowed)
71	X	X	X	S	156.575		US, Canada: Non-commercial (Recreational), International: Port operations and Ship movement
72	X	X	X	S	156.625		Non-commercial (Inter-ship only)
73	X	X	X	S	156.675		US: Port Operations, Canada: Commercial fishing only fishing only, International: Port operations and Ship movement
74	X	X	X	S	156.725		US: Port Operations, Canada: Commercial fishing only fishing only, International: Port operations and Ship movement
77	X	X	X	S	156.875		Port Operations (Inter-ship only)
78A	X	X		S	156.925		Non-commercial (Recreational)
78			X	D	156.925	161.525	Public Correspondence (Marine Operator), Port operation, ship movement
79A	X	X		S	156.975		Commercial
79			X	D	156.975	161.575	Port operation and Ship movement
80A	X	X		S	157.025		Commercial
80			X	D	157.025	161.625	Port operation, ship movement
81A	X	X		S	157.075		U.S. Government only-Environmental protection operations.
81			X	D	157.075	161.675	Port operation, ship movement
82A	X	X		S	157.125		U.S. Government only, Canadian Coast Guard Only
82			X	D	157.125	161.725	Public Correspondence (Marine Operator), Port operation, ship movement
83A	X	X		S	157.175		U.S. Government only, Canadian Coast Guard Only
83			X	D	157.175	161.775	Public Correspondence (Marine Operator)
84A	X			S	157.225		Public Correspondence (Marine Operator)
84	X	X	X	D	157.225	161.825	Public Correspondence (Marine Operator)

VHF MARINE CHANNEL CHART							
CH	U	C	I	S/D	TX	RX	CHANNEL USE
85A	X			S	157.275		Public correspondence (Marine Operator)
85	X	X	X	D	157.275	161.875	Public correspondence (Marine Operator)
86A	X			S	157.325		Public correspondence (Marine Operator)
86	X	X	X	D	157.325	161.925	Public correspondence (Marine Operator)
87A	X			S	157.375		Public correspondence (Marine Operator)
87	X	X	X	D	157.375	161.975	Public correspondence (Marine Operator)
88A	X			S	157.425		Commercial, Inter-ship Only
88		X	X	D	157.425	162.025	Public correspondence (ship-to-coast)
WX01	X	X	X	D	---	162.550	Weather (receive only)
WX02	X	X	X	D	---	162.400	Weather (receive only)
WX03	X	X	X	D	---	162.475	Weather (receive only)
WX04	X	X	X	D	---	162.425	Weather (receive only)
WX05	X	X	X	D	---	162.450	Weather (receive only)
WX06	X	X	X	D	---	162.500	Weather (receive only)
WX07	X	X	X	D	---	162.525	Weather (receive only)
WX08	X	X	X	D	---	161.650	Weather (receive only)
WX09	X	X	X	D	---	161.775	Weather (receive only)
WX10	X	X	X	D	---	163.275	Weather (receive only)

NOTES

Use this page to record important information, such as the serial number of your HT840, and any private channels programmed by your dealer.

3.5 SPECIFICATION(General, receive and transmit)

Performance specifications are nominal, unless otherwise indicated, and are subject to change without notice.

GENERAL

Frequency Range	TX/RX 156.000 - 163.275MHz
Type of emission	16K0F3E
Number of channels	58 (EXP. 36)
DC Power supply	7.4V DC
Current drain	Transmit 1.5A (High). 0.75A(Low) Receive 200mA, Standby 40mA
Duty cycle based on (5%-5%-90%)	15 hours (High) 19 hours (Low)
Frequency stability	+/-0.0005%
Temperature range	-20°C to +50°C
Dimensions	59(W)mm × 130(H)mm × 33(D)mm
Weight	296g (10.43 oz)
RF type approval	EN 300 178-2 V1.1.1 (2000-08)
LVD	EN 60950 August 1992, A11 1997
EMC	EN 60945 1997
ATIS	ETS 300 698 Annex December 1996

TRANSMITTER

RF output power (at 7.4V DC)	5W / 1W (High / Low)
Maximum frequency deviation	±5.0kHz
Spurious emissions	65dB
Adjacent channel power	-70 dB

RECEIVER

Receive system	Double conversion superheterodyne
Intermediate frequency	1st 21.7MHz
	2nd 450kHz
Sensitivity (12dB SINAD)	-119dBm
Adjacent channel selectivity	-74dB
Spurious response rejection	-70dB
Intermodulation rejection ratio	-68dB
Hum and noise	-48dB
Audio output (at 7.4V DC)	500mW(<5% distortion)
	distortion with an 8Ω load

Certification

USTC Certified
Intrinsically Safe
Classes I, II & III
GROUPS A TO G, DIV I & II T4

- ▶ The **HT840** must always be used within the terms of its certification
- ▶ Keep **HT840** away from aggressive substances. If used in a hostile environment, extra protection may be needed.
- ▶ To prevent ignition of hazardous atmospheres, batteries must only be charged or changed in an area known to be non hazardous.
- ▶ No unauthorised repairs are permitted. Details of authorised service centres are available from Entel UK.

3.5.1 PRIVATE CHANNELS

The **HT840** has the capacity for a further 36 private channels. These channels are dealer programmable only.

FOR USA VERSION:- SAFETY TRAINING INFORMATION

WARNING.

Your Entel radio generates RF electromagnetic energy during transmit mode. This radio is designed for and classified as "Occupational Use Only", meaning it must be used only during the course of employment by individuals aware of the hazards, and the ways to minimize such hazards. This radio is NOT intended for use by the "General Population" in an uncontrolled environment.

Use only Entel approved accessories. Use of accessories other than those specified may result in RF exposure levels exceeding the FCC requirements for wireless RF exposure.

CAUTION.

To ensure that your exposure to RF electromagnetic energy is within the FCC allowable limits for occupational use, always adhere to the following guidelines:-

► **DO NOT** operate the radio without a proper antenna attached, as this may damaged the radio and may also cause you to exceed FCC RF exposure limits. A proper antenna is the antenna supplied with this radio by the manufacturer or antenna specifically authorized by the manufacturer for use with this radio.

► **DO NOT** transmit for more than 50% of total radio use time ("50% duty cycle"). Transmitting more than 50% of the time can cause FCC RF exposure compliance requirements to be exceeded. The radio is transmitting when the "TX indicator" lights red. You can cause the radio to transmit by pressing the "PTT" switch.

► **ALWAYS** keep the antenna at least 2.5 cm (1 inch) away from the body when transmitting and only use approved accessories to ensure FCC RF exposure compliance requirements are not exceeded. To provide the recipients of your transmission the best sound quality, hold the transceiver at least 5 cm (2 inches) from your mouth, and slightly off to one side. The information listed above provides the user with the information needed to make him or her aware of RF exposure, and what to do to ensure that this radio operates within the FCC RF exposure limits.

Electromagnetic Interference/Compatibility

During transmissions, your Entel radio generates RF energy that can possibly cause interference with other devices or systems. To avoid such interference, turn off the radio in areas where signs are posted to do so. DO NOT operate the transmitter in areas that are sensitive to electromagnetic radiation such as hospitals, aircraft, and blasting sites.

Occupational/Controlled Use

The radio transmitter is used in situations in which persons are exposed as a consequence of their employment. These persons should be made fully aware of the potential for exposure so they can exercise control over their exposure.

Changes or modifications to this device, not expressly Approved by Entel UK could invalidate your authority to Operate this device under FCC regulations.

Complete HT Series application guide for land and marine models:-

Model	Land	Marine	VHF	UHF	*ATEX(I.S)	U.S.T.C	Channels	*PMR446	GMDSS
HT446	✓	X	X	✓	X	X	8	✓	X
HT640	X	✓	✓	X	X	X	55 MARINE	X	X
HT720	✓	X	✓	X	X	X	128	X	X
HT780	✓	✓	X	✓	X	X	128	X	X
HT820	✓	X	✓	X	X	✓	128	X	X
HT840	X	✓	✓	X	X	✓	55 MARINE	X	X
HT880	✓	✓	X	✓	X	✓	128	X	X
HT920	✓	X	✓	X	✓	X	128	X	X
HT940	X	✓	✓	X	✓	X	55 MARINE	X	X
HT980	✓	✓	X	✓	✓	X	128	X	X
HT70	X	✓	✓	X	X	X	UP TO 55 MARINE	X	✓

I.S = intrinsically safe for hazardous applications

*only for use in Europe

<Intended Country of Use>

- GER NED ITA NOR
 AUT BEL GRE SUI
 GBR LUX SWE
 IRL ESP DEN
 FRA POR FIN

CE0891 ⚠

Registered Community Design Application 000044375

U.S Design Patent Pending No. 29/183,829

Copyright and Unregistered Design Right Entel UK 2003.

All rights reserved

Copy Right Entel UK Ltd, London