

# BASE TRANSMITTER (MAGNETRON)

# CHAPTER 2



## USER MANUAL

## INSIDE CHAPTER 2

General Information	2-3
Power Distribution Unit	2-7
System Power Supply	2-8
Power Distribution Block	2-9
Magnetron Blower Assembly	2-10
Alarm Current Monitor	2-11
Temperature Sensors	2-12
Distribution Data Collection Module	2-13
Transmitter Maintenance Panel	2-14
Transmitter I/O Panel	2-15
Transmitter Supplemental - Dual Port Power Sensor	2-17

# GENERAL INFORMATION

The base transmitter 1A1, is the foundation for the radar system and foundation consists of the necessary power distribution, cooling, system control, and various other modules that provide the transmitter with the necessary items for proper operation. The base transmitter is not frequency or power determinate, rather the base transmitter provides the infrastructure to other modules. For more detail, reference schematic book Volume 3. Numerous options exist within the base transmitter; refer to the family tree for your configuration.

The Base Transmitter serves as host for the specific modulator and waveguide modules detailed in Chapter 2 to operate within various radar bands:

S-Band 2700 – 3000MHz.

C-Band 5200 – 5900MHz.

X-Band 8500 – 9600MHz.

The Base Transmitter consists of the following major functional areas:

AC & DC Power.

Power Distribution Unit (1A1A2)

System Power Supply (1A1PS1)

Power Distribution Block (1A1A4)

Cooling.

Magnetron Blower Assembly (1A1A6)

Alarm Current Monitor (1A1A11)

Temperature Sensors (TEMP 1, TEMP 2)

Control and Monitoring.

Distributed Data Collection Module (1A1A5)

Dual RF Power Sensor (1A1A7)

Interface.

Transmitter Maintenance Panel (1A1A9)

Transmitter I/O Panel (1A1A10)

Please see the next page for location of these modules within the base transmitter cabinet.

# GENERAL INFORMATION

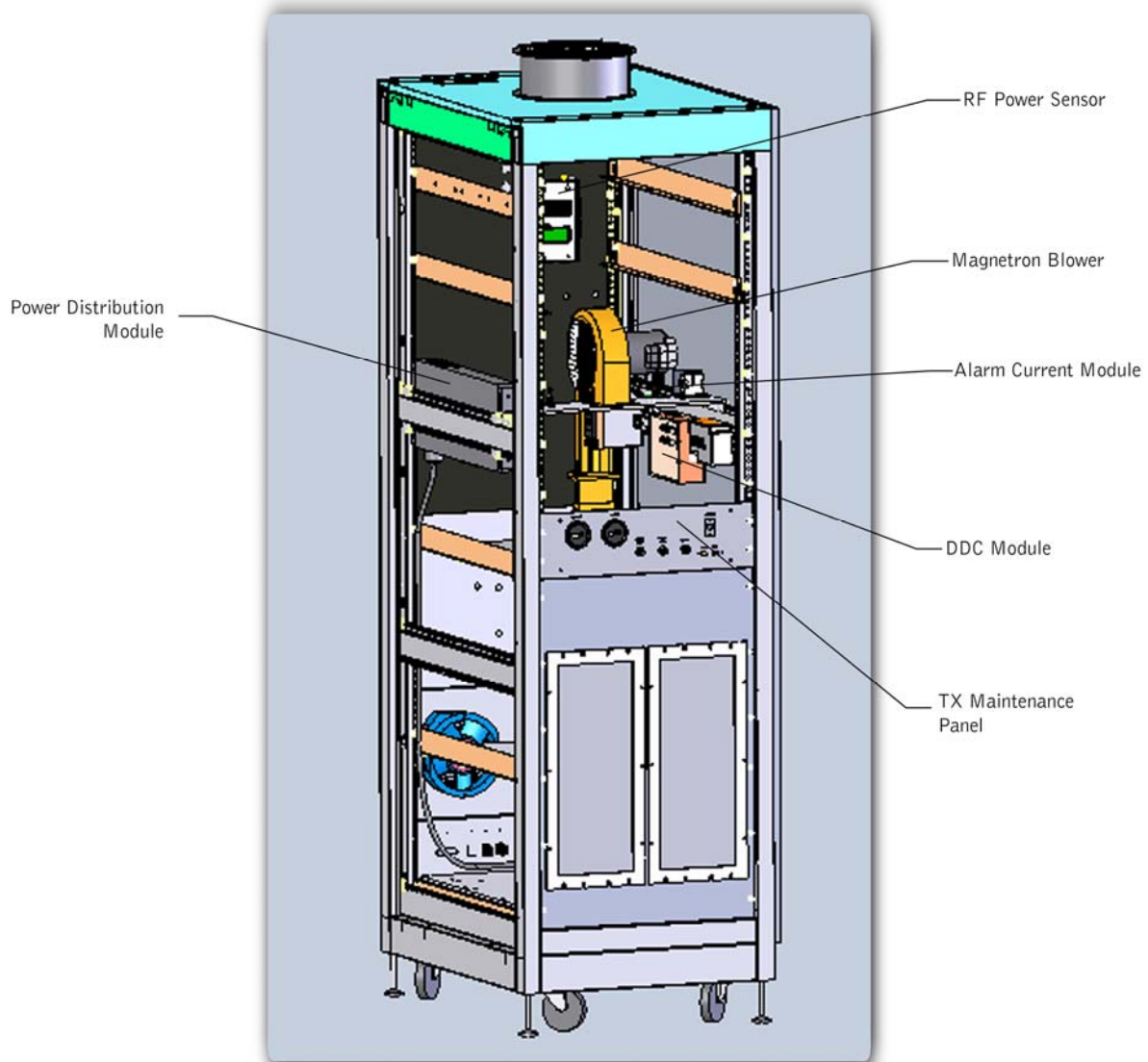

# GENERAL INFORMATION

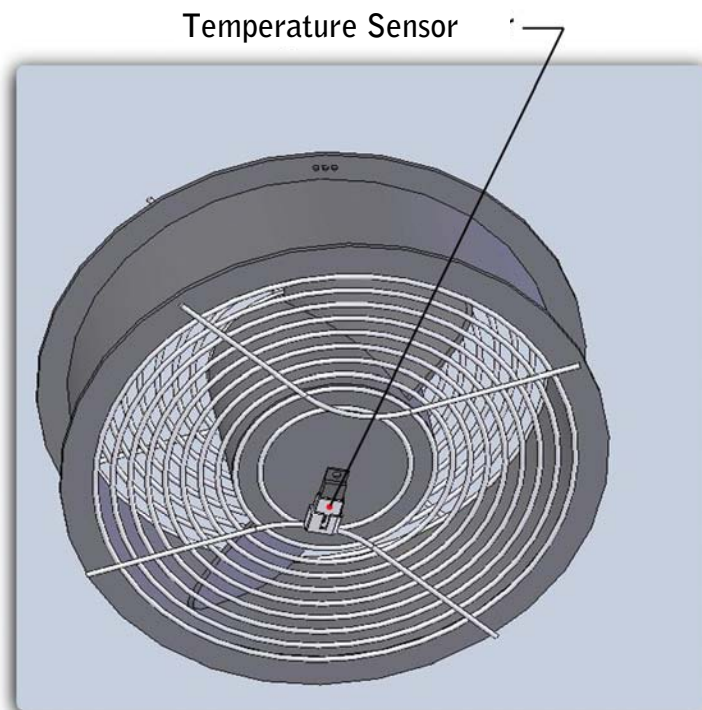
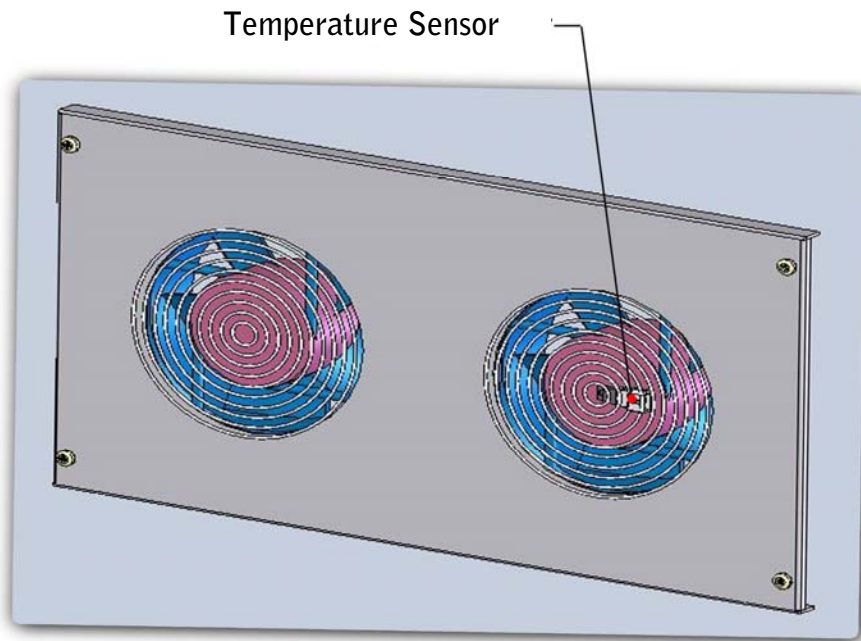

# GENERAL INFORMATION

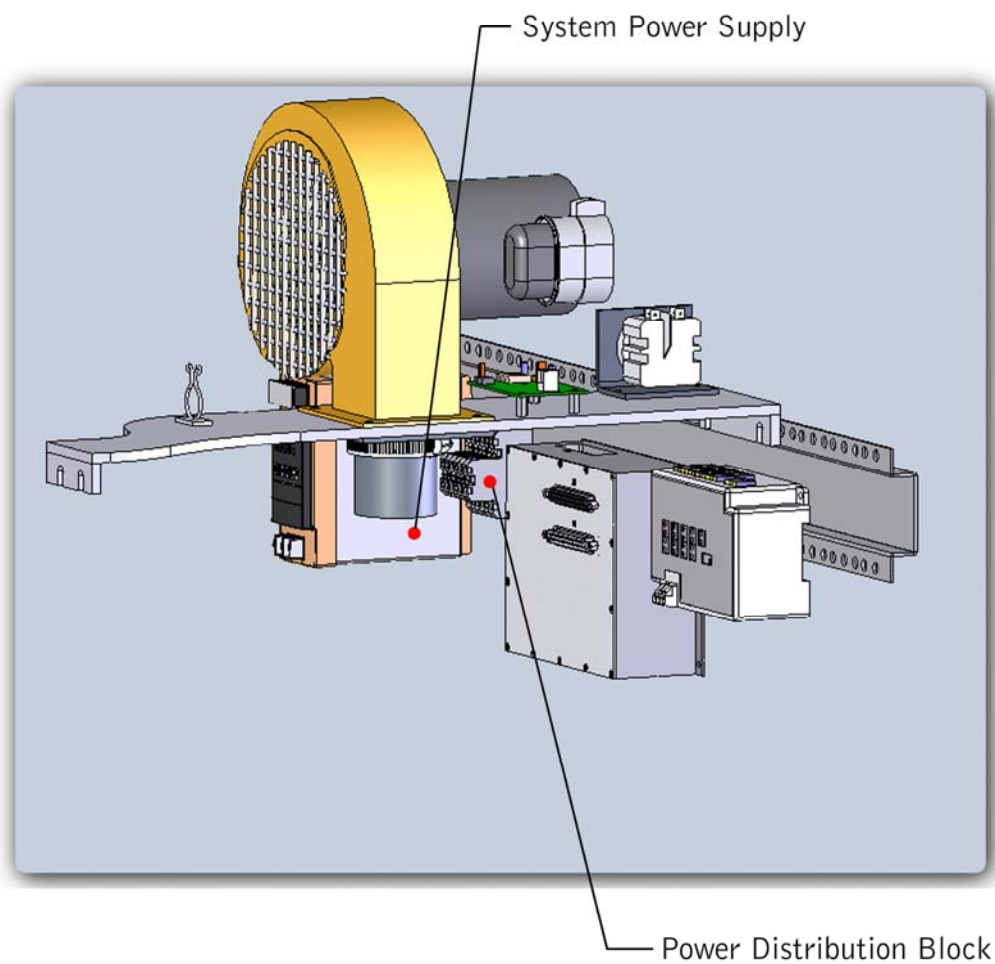

# POWER DISTRIBUTION MODULE

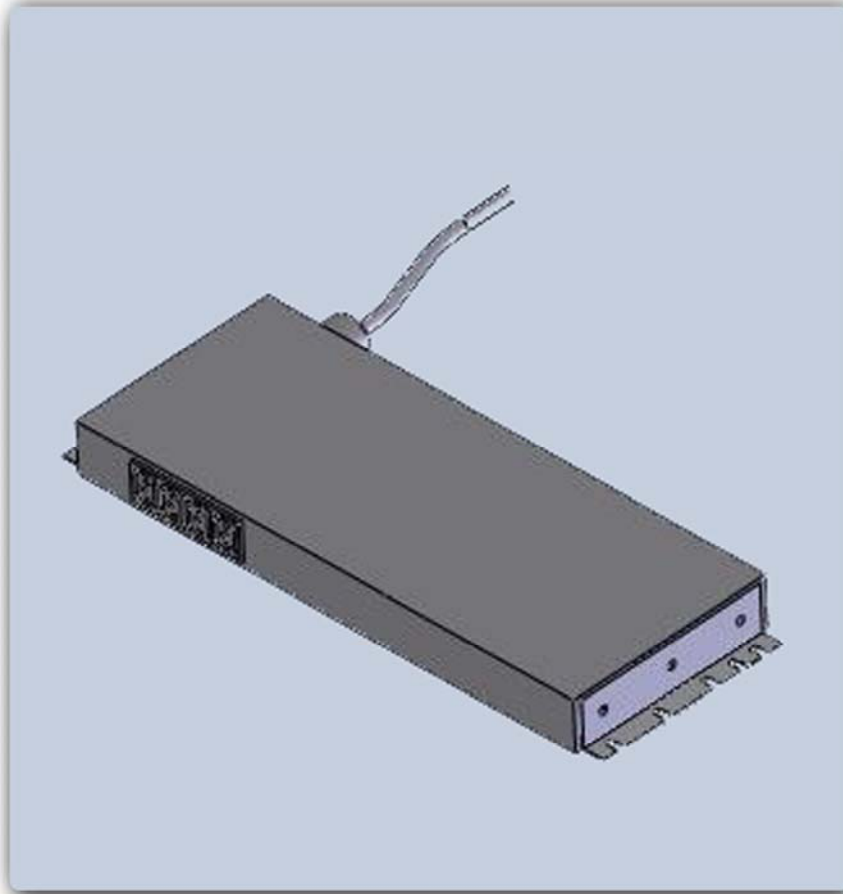

The power distribution module accepts the incoming Mains AC from the transmitter IO panel, and provides a convenient central point of distribution. The module also contains filtering circuitry to reduce EMI. This module accepts standard IEC-C13 and C19 plugs. Each of the various modules within the base transmitter plug into this distribution unit

# SYSTEM POWER SUPPLY

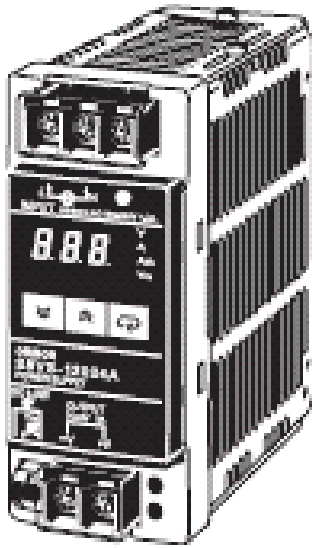

The system power supply is a +24VDC 120W supply capable of providing the source for the base transmitter unit. This supply is a high efficiency switching supply with LED indication of Voltage and current for ease of maintenance. The supply is DIN rail mounted and has covers protecting the AC Mains input and DC output.

The following illustrates the basic features of this supply:

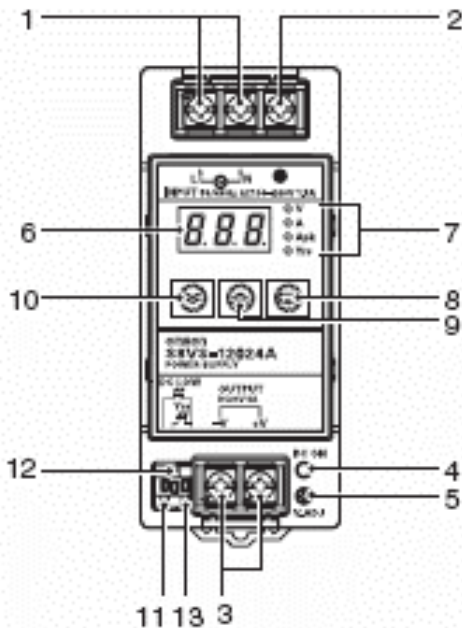

1	AC Input terminals
2	Chassis ground terminal
3	DC output terminal
4	Output Indicator LED
5	Output Voltage adjust potentiometer
6	Main LED Display
7	LED Display Mode
8	Display Mode Key
9	Mode Up Key
10	Mode Down Key
11	Alarm Output terminal
12	Maintenance forecast terminal
13	Common for terminals



# POWER DISTRIBUTION BLOCK

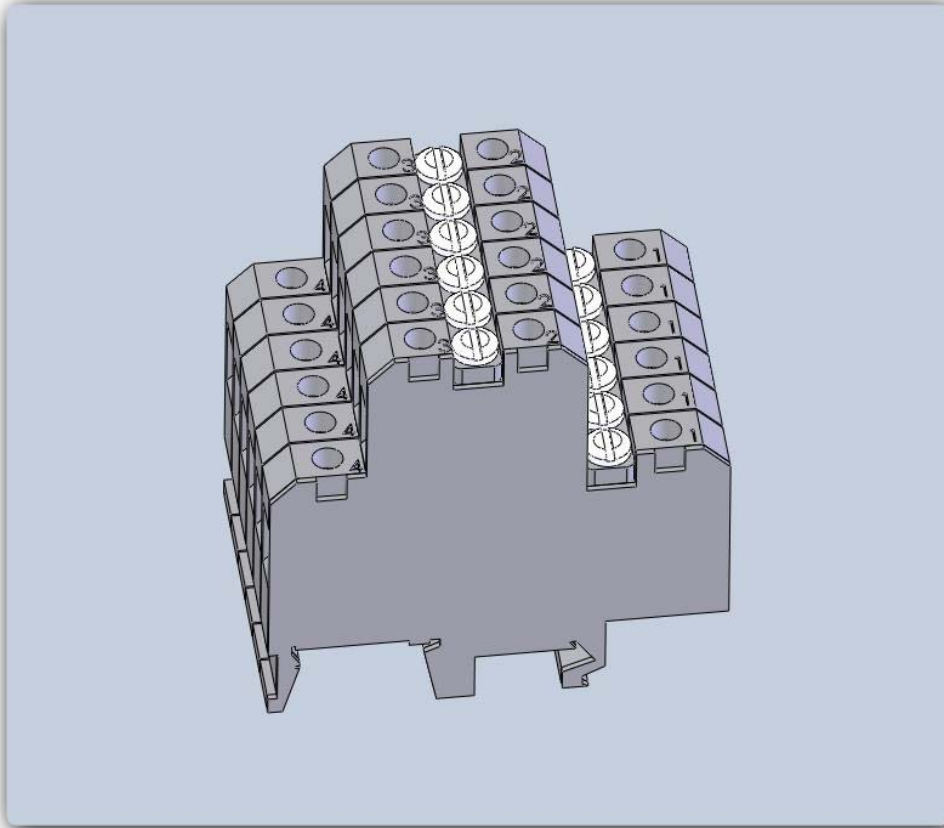

This DIN rail distribution buss is comprised of 6 individual modules connected by a common buss. This distributes both +24VDC and Ground. The terminals are recessed to minimize the risk of short circuit due to foreign debris. All the contacts are properly coated to reduce the risk of corrosion, and to operate without vibration, which could cause individual contacts to loosen. The unit is an industry standard method for proper distribution of low Voltages. No periodic maintenance is required.

# MAGNETRON BLOWER ASSEMBLY

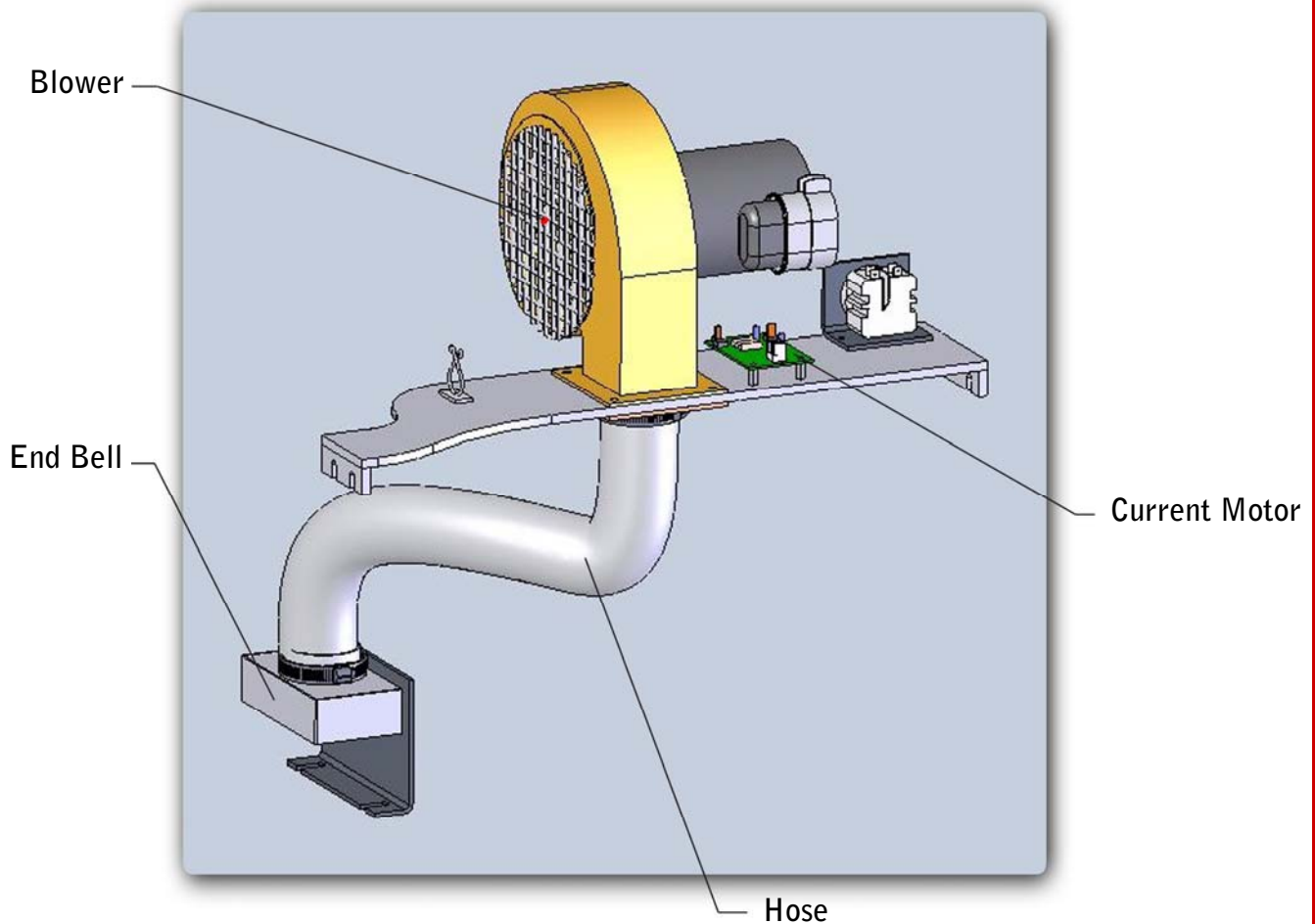

The Magnetron blower assembly is the typical cooling system for the Magnetron tube. Pictured above is the assembly with the hose and end-bell for use with the EEC Magnetron tubes. Each Magnetron tube type uses a different hose and end-bell arrangement but is similar to the one pictured. A screen shroud is placed over the blower inlet to keep an object from striking the spinning rotor. The blower is capable of moving approximately 250CFM at 1" of backpressure ensuring maximum cooling of the Magnetron tube

# ALARM CURRENT MONITOR

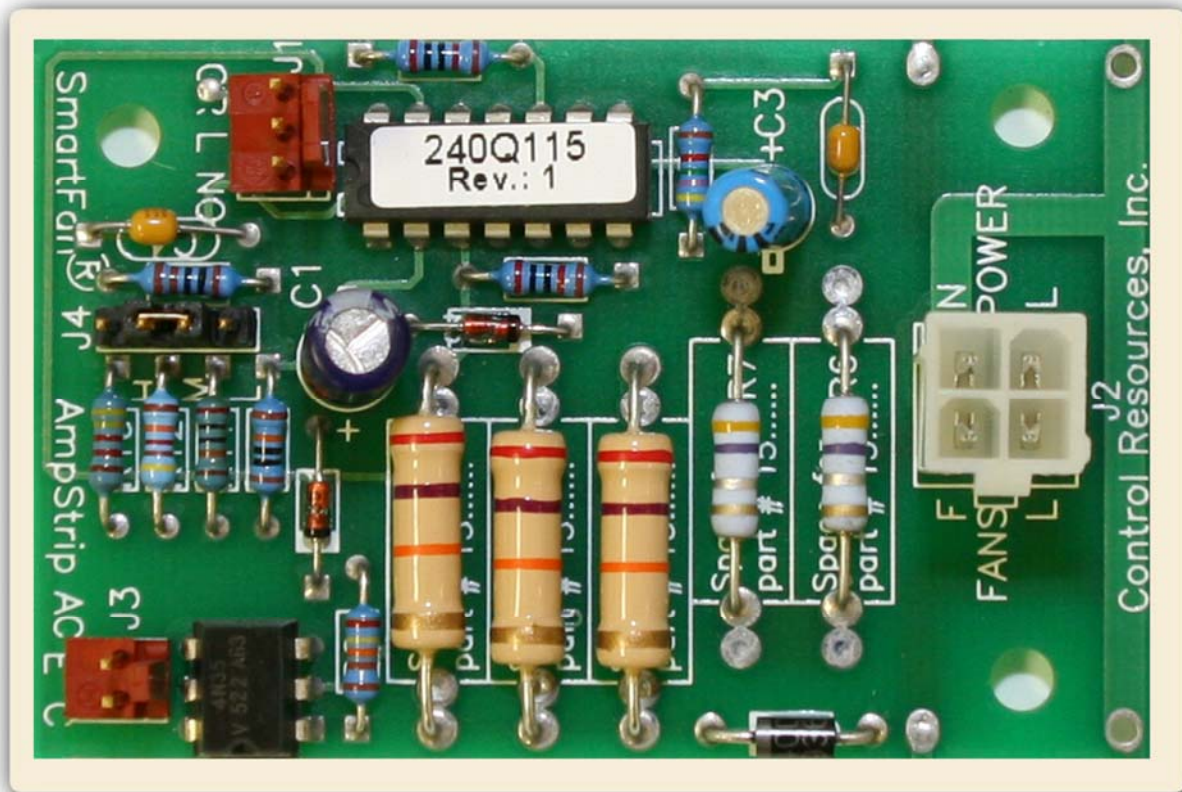

Pictured above is the Alarm current sensor and alarm circuit board mounted on the Magnetron Blower Assembly. This module monitors the Magnetron blower for proper operation via current flow. If the current drops below a pre-set limit due to either motor failure or other faults, the alarm circuit initiates a controlled shutdown of the transmitter thus preventing damage of critical components. There are no adjustments or other periodic maintenance required.

# TEMPERATURE SENSORS

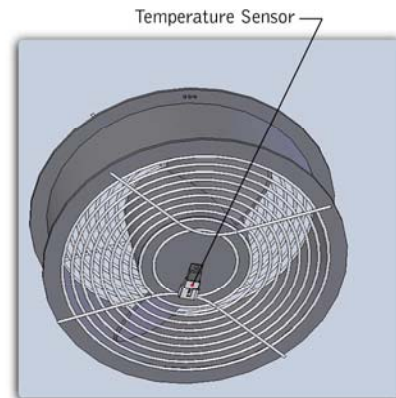
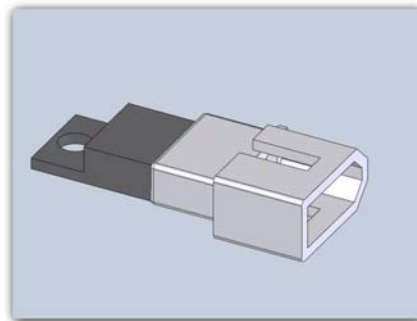
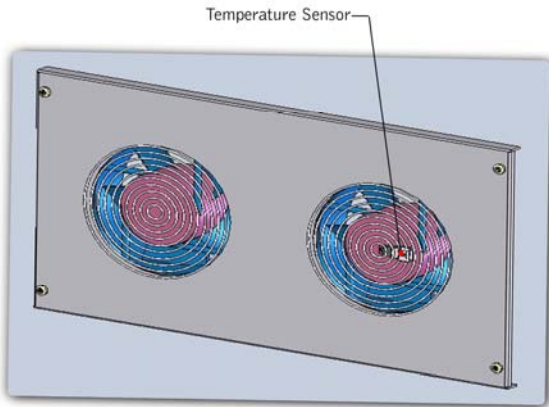

The temperature sensors used in the base transmitter unit are precision semi-conductor temperature to Voltage converters. Additional circuitry is provided to compensate for cable length and to eliminate pulse noise. Both temperature sensors are fed to the DDC module and the information is used both for BITE data and for transmitter monitoring .

# DISTRIBUTED DATA COLLECTION MODULE

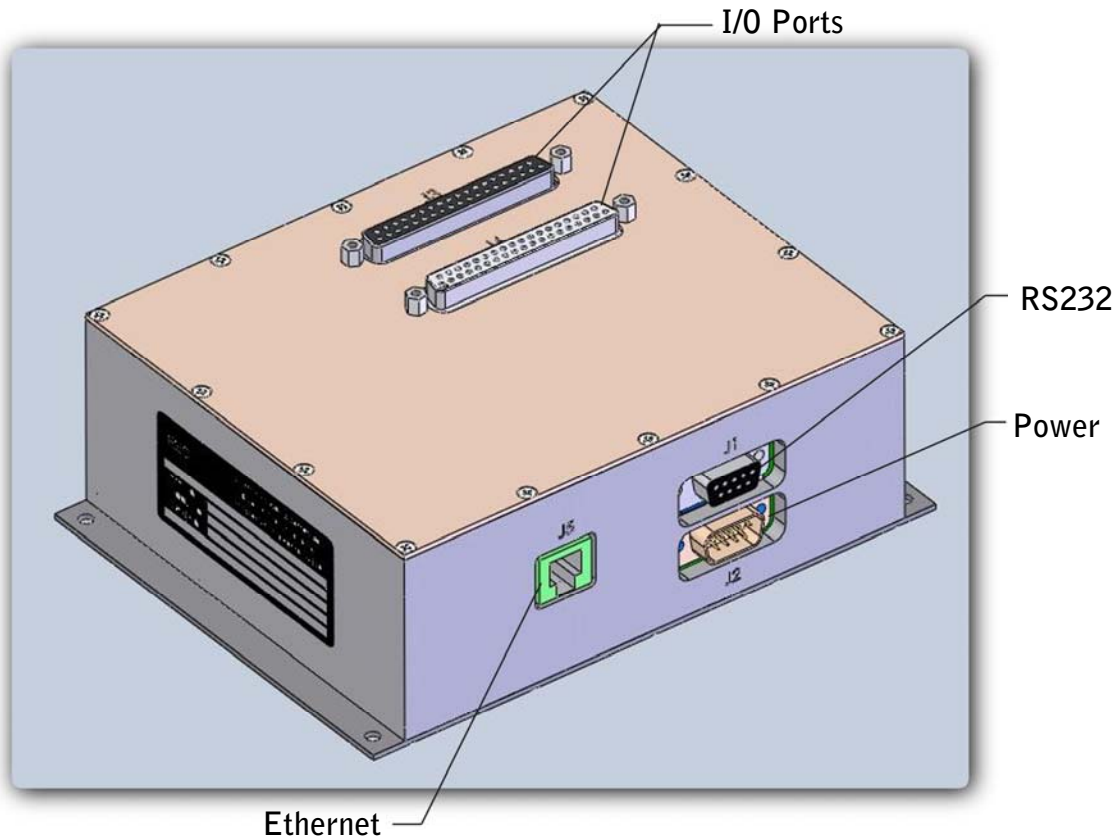

The Distributed Data Collection (DDC) module is an Ethernet, CAN, or serial RS232 controlled device that collects both analog and digital data, as well as controls relays. It outputs TTL signals under processor control. For general information please refer to EEC Publication DDC-ICD and Users manual. For further information refer to the Personality Addendum in the DDC Users Manual. The DDC module controls the base transmitter, Solid State modulator systems, and provides control and monitoring of the temperatures. The DDC also acts as the “gateway” for the Ethernet data stream, providing one component that is the primary data collector and disseminator easing interface programming.

The Distributed Data Collection Module (DDC) Interface Control Document (ICD) provides textual detail of the Distributed Data Collection Module (DDC)

# TRANSMITTER MAINTENANCE PANEL

Two different options for the transmitter maintenance panel exist; one incorporates a pedestal intercom function, and the other doesn't. Both configurations will be shown in this document. Please refer to the FAMILY TREE for your specific unit.

The functions of this panel, which are common to both configurations, are run-time meter displays, forward and reverse detected RF, trigger output, Ethernet interface, and USB 2.0 connectors for the optional touch screen computer. The panel is shown below.

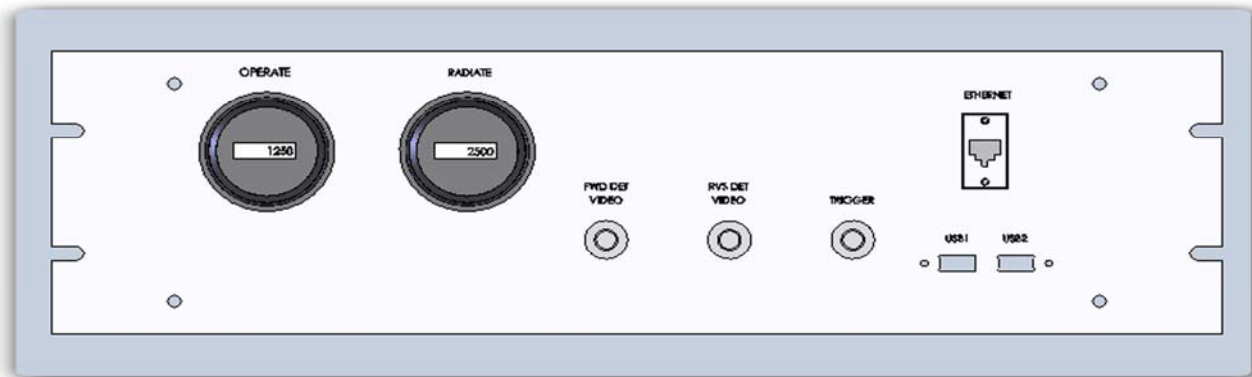

- **Operate Time Meter** – Provides visual display of the hours of operation of the base transmitter unit. This display is typically used to determine the hours of operation of the Magnetron tube filaments.
  - **Radiate Time Meter** – Display of hours the unit is in transmit operation.
  - **Trigger Test Jack** – Used to trigger external test equipment by the system trigger generated in the base transmitter unit. This trigger is +5VDC positive going.
  - **Forward Detected RF** – Connect to an oscilloscope to view the detected pulse of the transmitter. The oscilloscope should have a bandwidth limit set at around 20MHz, or an external low-pass filter with a cutoff of approximately 20MHz should be used for optimum results. For Indication only. See Chapter 6 Maintenance section for Pulse Width Measurement.
  - **Reverse Detected RF** – Connect to an oscilloscope to view the detected pulse of the transmitter. The oscilloscope should have a bandwidth limit set at around 20MHz, or an external low-pass filter with a cutoff of approximately 20MHz should be used for optimum results. See Chapter 6 Maintenance section for Pulse Width Measurement.
  - **Ethernet Port** – Use for direct Ethernet connection to the base transmitter hub. An external computer with optional EEC software can be connected to this port for transmitter control during maintenance if the optional touch screen interface is not utilized.
- USB 1 and USB 2 Ports** – These ports are used only with the optional touch screen option and allows a mouse and keyboard to be connected. These are not required for regular use of the touch screen, though the user may be more comfortable with this method of control.

# TRANSMITTER MAINTENANCE PANEL

The optional pedestal intercom incorporates all the functions described above, and adds a headphone jack, push to alert button, a sonic alert device, and RF sample ports for forward and reverse power.

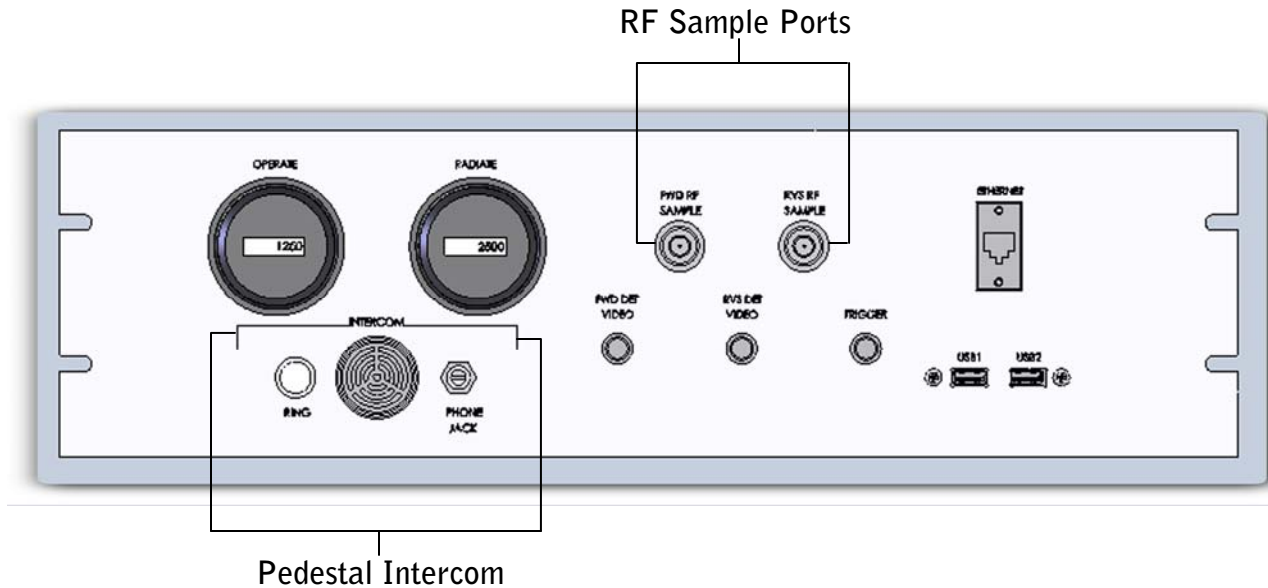

# TRANSMITTER I/O PANEL

The transmitter I/O panel is the main interface point between the base transmitter, the external communication network, and pedestal equipment. For full details concerning the signal characteristics of the interface panel, please refer to EEC Publication BASE TRANSMITTER I/O ICD. The various connectors provided perform the following functions.

- **E1** – Chassis Ground
- **J1** – AC Mains Input
- **J2** – Unassigned
- **J3 – J5** – Ethernet Communications
- **J6** – Auxiliary monitoring connector

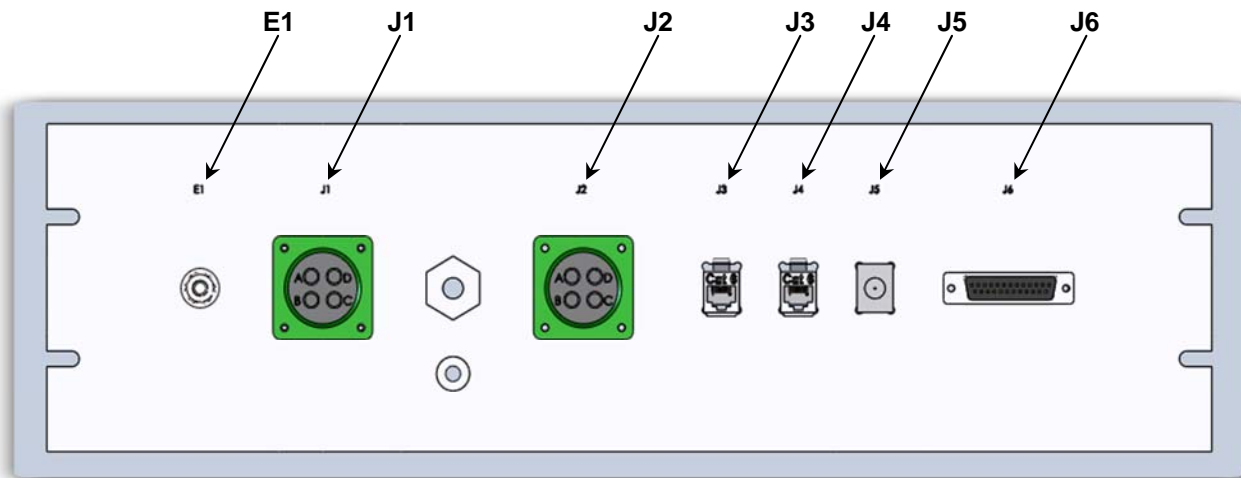

The Base Transmitter I/O Interface Control Document (ICD) provides textual detail of the Base Transmitter I/O Modulator Assembly.



# TRANSMITTER SUPPLEMENTAL

## Dual Port Power Sensor

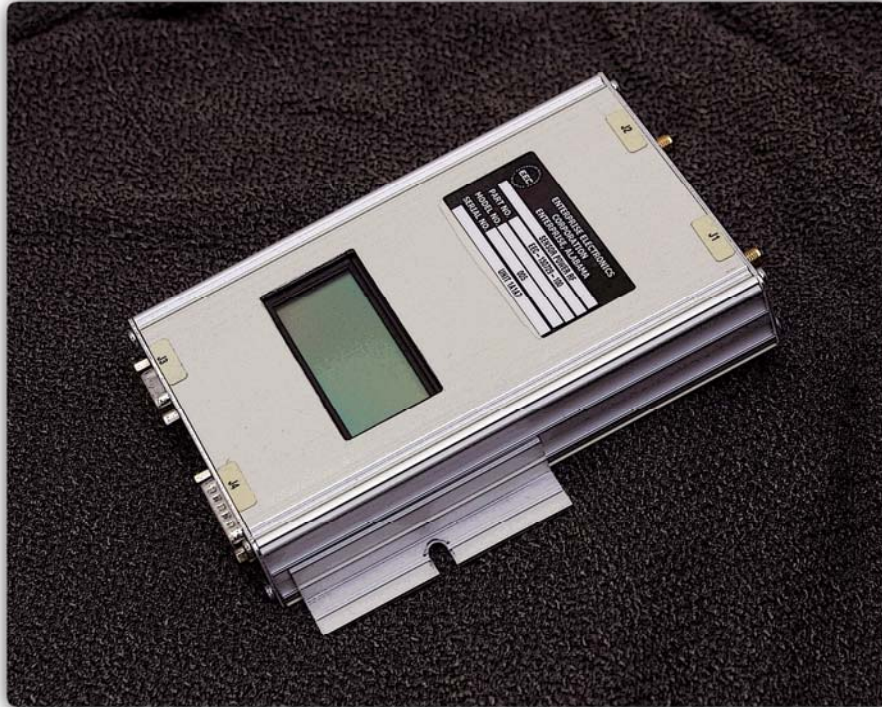

The Dual Port Power Sensor provides a real time analysis of the transmitted pulse and reverse power. Measuring both forward and reflected power from the waveguide assembly bi-directional coupler allows for indication of the transmitted pulse and the reflected energy. Since reflected energy is also comprised of weather information, the reverse energy is only measured during the transmitted pulse width. If a problem exists in the waveguide, from the transmitter to the feed-horn, this reflected energy will be sensed, and depending on the measured VSWR in the power monitor, the transmitter can be configured to shut-down until the problem is resolved. An LCD display on the front of the power monitor gives readouts of forward power, reverse power, both in dBm and in KiloWatts. The information displayed on the power monitor is also fed to the DDC module for incorporation into the BITE data stream for remote viewing. The power monitor can measure power of RF pulses that are at least  $0.4\mu\text{s}$  in width. For complete information about the various modes of operation and in setting the user parameters please refer to EEC Publications; Dual Port Power Monitor User Manual, and Dual Port Power Monitor ICD.

The Dual Port Power Sensor Interface Control Document (ICD) provides textual detail of the Dual RF Power Sensor